

AASHTO LRFD BRIDGE

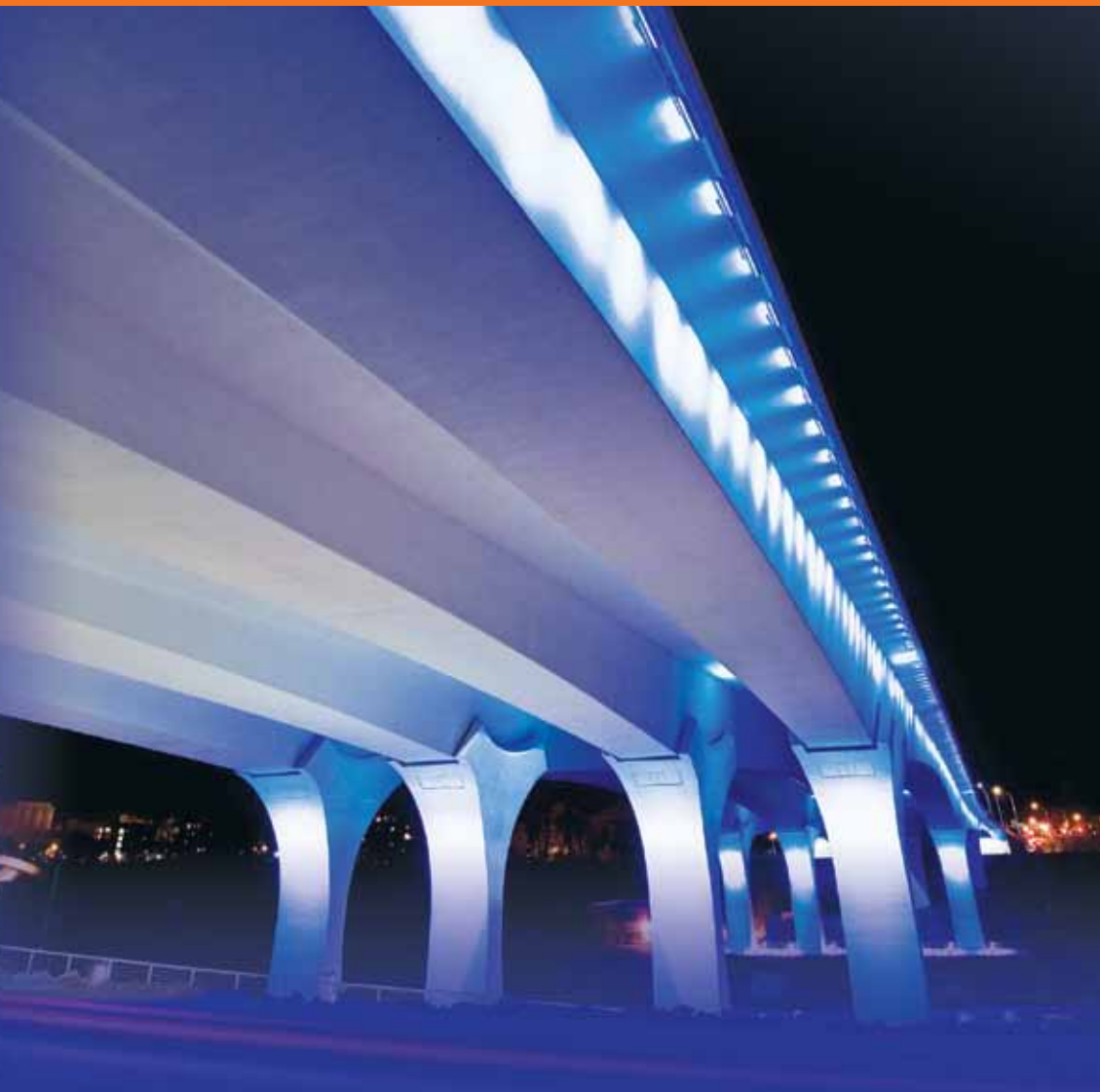

DESIGN SPECIFICATIONS

Customary U.S. Units • 2012

ISBN: 978-1-56051-523-4
Code: DVT@ June 2013 LRFUS-6

AMERICAN ASSOCIATION OF
STATE HIGHWAY AND
TRANSPORTATION OFFICIALS

AASHTO
THE VOICE OF TRANSPORTATION

AASHTO LRFD BRIDGE



DESIGN SPECIFICATIONS

Customary U.S. Units • 2012

ISBN: 978-1-56051-523-4
Publication Code: LRFDUS-6

AMERICAN ASSOCIATION OF
STATE HIGHWAY AND
TRANSPORTATION OFFICIALS

AASHTO
THE VOICE OF TRANSPORTATION



American Association of State Highway and Transportation Officials
444 North Capitol Street, NW Suite 249
Washington, DC 20001
202-624-5800 phone/202-624-5806 fax
www.transportation.org

© 2012 by the American Association of State Highway and Transportation Officials. All rights reserved. Duplication is a violation of applicable law.

EXECUTIVE COMMITTEE

2010–2011

Voting Members

Officers:

President: Kirk T. Steudle, P.E., Michigan*

Vice President: Michael P. Lewis, Rhode Island*

Secretary-Treasurer: Carlos Braceras, Utah

Regional Representatives:

REGION I: Beverley Swaim-Staley, Maryland, One-Year Term
James P. Redeker, Connecticut, Two-Year Term

REGION II: Robert St. Onge, South Carolina, One-Year Term
Eugene Conti, North Carolina, Two-Year Term

REGION III: Kevin Keith, Missouri, One-Year Term
Mark Gottlieb, Wisconsin, Two-Year Term

REGION IV: Francis Ziegler, North Dakota, One-Year Term
John Cox, Wyoming, Two-Year Term

Nonvoting Members

Immediate Past President: Susan Martinovich, Nevada

AASHTO Executive Director: John Horsley, Washington, DC

***Elected at the 2011 Annual Meeting in Detroit, Michigan**

HIGHWAY SUBCOMMITTEE ON BRIDGES AND STRUCTURES 2011

MALCOLM T. KERLEY, *Chair*

DAVID P. HOHMANN, *Vice Chair*

M. MYINT LWIN, Federal Highway Administration, *Secretary*

RAJ AILANEY, Federal Highway Administration, *Assistant Secretary*

KEITH M. PLATTE, *AASHTO Liaison*

KELLEY REHM, *AASHTO Liaison*

ALABAMA, John F. Black, William “Tim” Colquett

ALASKA, Richard A. Pratt

ARIZONA, Jean A. Nehme

ARKANSAS, Carl Fuselier

CALIFORNIA, Barton J. Newton, Susan Hida,
Michael Keever

COLORADO, Mark A. Leonard, Michael G. Salamon

CONNECTICUT, Julie F. Georges

DELAWARE, Jiten K. Soneji, Barry A. Benton

DISTRICT OF COLUMBIA, Ronaldo T. “Nick”
Nicholson, L. Donald Cooney, Konjit “Connie”
Eskender

FLORIDA, Sam Fallaha, Dennis Golabek, Jeff Pouliotte

GEORGIA, Paul V. Liles, Jr.

HAWAII, Paul T. Santo

IDAHO, Matthew M. Farrar

ILLINOIS, D. Carl Puzey, Tim Armbrecht, Thomas J.
Domagalski

INDIANA, Anne M. Rearick

IOWA, Norman L. McDonald

KANSAS, James J. Brennan, Loren R. Risch

KENTUCKY, Mark Hite, Marvin Wolfe

LOUISIANA, Hossein Ghara, Arthur D’Andrea, Paul
Fossier

MAINE, David B. Sherlock, Jeffrey S. Folsom, Wayne
Frankhauser, Jr.

MARYLAND, Earle S. Freedman, Robert J. Healy,
Jeffrey L. Robert

MASSACHUSETTS, Alexander K. Bardow, Shoukry
Elnahal

MICHIGAN, Steven P. Beck, David Juntunen

MINNESOTA, Nancy Daubenberger, Kevin Western

MISSISSIPPI, Mitchell K. Carr, B. Keith Carr

MISSOURI, Dennis Heckman, Michael Harms

MONTANA, Kent M. Barnes

NEBRASKA, Mark J. Traynowicz, Mark Ahlman,
Fouad Jaber

NEVADA, Mark P. EliceGUI, Todd Stefonowicz

NEW HAMPSHIRE, Mark W. Richardson, David L.
Scott

NEW JERSEY, (Vacant)

NEW MEXICO, Raymond M. Trujillo, Jimmy D. Camp

NEW YORK, Wahid Albert, Donald F. Dwyer, Arthur
P. Yannotti

NORTH CAROLINA, Greg R. Perfetti, Dan
Holderman

NORTH DAKOTA, Terrence R. Udland

OHIO, Timothy J. Keller, Jawdat Siddiqi

OKLAHOMA, Robert J. Rusch, Gregory D. Allen,
John A. Schmiedel

OREGON, Bruce V. Johnson, Hormoz Seradj

PENNSYLVANIA, Thomas P. Macioce, Lou Ruzzi

PUERTO RICO, (Vacant)

RHODE ISLAND, David Fish

SOUTH CAROLINA, Barry W. Bowers, Jeff Sizemore

SOUTH DAKOTA, Kevin Goeden

TENNESSEE, Edward P. Wasserman

TEXAS, Keith L. Ramsey, David P. Hohmann

U.S. DOT, M. Myint Lwin, Raj Ailaney

UTAH, Carmen Swanwick

VERMONT, Wayne B. Symonds

VIRGINIA, Malcolm T. Kerley, Kendal Walus, Prasad
L. Nallapaneni, Julius F. J. Volgyi, Jr.

WASHINGTON, Jugesh Kapur, Tony M. Allen, Bijan
Khaleghi

WEST VIRGINIA, Gregory Bailey, James D. Shook

WISCONSIN, Scot Becker, Beth A. Cannestra, William
Dreher

WYOMING, Paul G. Cortez, Michael E.
Menghini, Keith R. Fulton

GOLDEN GATE BRIDGE, Kary H. Witt

MDTA, Dan Williams

N.J. TURNPIKE AUTHORITY, Richard J. Raczynski

N.Y. STATE BRIDGE AUTHORITY, William J.
Moreau

PENN. TURNPIKE COMMISSION, James L. Stump

TRANSPORTATION RESEARCH BOARD,
Waseem Dekelbab

U.S. ARMY CORPS OF ENGINEERS—

DEPARTMENT OF THE ARMY, Phillip W.
Sausser, Christopher H. Westbrook

U.S. COAST GUARD, Hala Elgaaly

U.S. DEPARTMENT OF AGRICULTURE—
FOREST SERVICE, Tom Gillins

ALBERTA, Lloyd Atkin

KOREA, Eui-Joon Lee, Sang-Soon Lee

NEWFOUNDLAND, Peter Lester **NOVA SCOTIA**,
Mark Pertus

ONTARIO, Bala Tharmabala

SASKATCHEWAN, Howard Yea

FOREWORD

The first broadly recognized national standard for the design and construction of bridges in the United States was published in 1931 by the American Association of State Highway Officials (AASHO), the predecessor to AASHTO. With the advent of the automobile and the establishment of highway departments in all of the American states dating back to just before the turn of the century, the design, construction, and maintenance of most U.S. bridges was the responsibility of these departments and, more specifically, the chief bridge engineer within each department. It was natural, therefore, that these engineers, acting collectively as the AASHTO Highway Subcommittee on Bridges and Structures, would become the author and guardian of this first bridge standard.

This first publication was entitled *Standard Specifications for Highway Bridges and Incidental Structures*. It quickly became the *de facto* national standard and, as such, was adopted and used by not only the state highway departments but also other bridge-owning authorities and agencies in the United States and abroad. Rather early on, the last three words of the original title were dropped and it has been reissued in consecutive editions at approximately four-year intervals ever since as *Standard Specifications for Highway Bridges*, with the final 17th edition appearing in 2002.

The body of knowledge related to the design of highway bridges has grown enormously since 1931 and continues to do so. Theory and practice have evolved greatly, reflecting advances through research in understanding the properties of materials, in improved materials, in more rational and accurate analysis of structural behavior, in the advent of computers and rapidly advancing computer technology, in the study of external events representing particular hazards to bridges such as seismic events and stream scour, and in many other areas. The pace of advances in these areas has, if anything, stepped up in recent years. To accommodate this growth in bridge engineering knowledge, the Subcommittee on Bridges and Structures has been granted authority under AASHTO's governing documents to approve and issue Bridge Interims each year, not only with respect to the Standard Specifications but also to incrementally modify and enhance the twenty-odd additional documents on bridges and structures engineering that are under its guidance and sponsorship.

In 1986, the Subcommittee submitted a request to the AASHTO Standing Committee on Research to undertake an assessment of U.S. bridge design specifications, to review foreign design specifications and codes, to consider design philosophies alternative to those underlying the Standard Specifications, and to render recommendations based on these investigations. This work was accomplished under the National Cooperative Highway Research Program (NCHRP), an applied research program directed by the AASHTO Standing Committee on Research and administered on behalf of AASHTO by the Transportation Research Board (TRB). The work was completed in 1987, and, as might be expected with a standard incrementally adjusted over the years, the Standard Specifications were judged to include discernible gaps, inconsistencies, and even some conflicts. Beyond this, the specification did not reflect or incorporate the most recently developing design philosophy, load-and-resistance factor design (LRFD), a philosophy which has been gaining ground in other areas of structural engineering and in other parts of the world such as Canada and Europe.

From its inception until the early 1970s, the sole design philosophy embedded within the Standard Specifications was one known as working stress design (WSD). WSD establishes allowable stresses as a fraction or percentage of a given material's load-carrying capacity, and requires that calculated design stresses not exceed those allowable stresses. Beginning in the early 1970s, WSD began to be adjusted to reflect the variable predictability of certain load types, such as vehicular loads and wind forces, through adjusting design factors, a design philosophy referred to as load factor design (LFD). Both WSD and LFD are reflected in the current edition of the Standard Specifications.

A further philosophical extension results from considering the variability in the properties of structural elements, in similar fashion to load variabilities. While considered to a limited extent in LFD, the design philosophy of load-and-resistance factor design (LRFD) takes variability in the behavior of structural elements into account in an explicit manner. LRFD relies on extensive use of statistical methods, but sets forth the results in a manner readily usable by bridge designers and analysts.

With the advent of these specifications, bridge engineers had a choice of two standards to guide their designs, the long-standing AASHTO *Standard Specifications for Highway Bridges*, and the alternative, newly adopted *AASHTO LRFD Bridge Design Specifications*, and its companions, *AASHTO LRFD Bridge Construction Specifications* and *AASHTO LRFD Movable Highway Bridge Design Specifications*. Subsequently, the Federal Highway Administration (FHWA) and the states have established a goal that LRFD standards be incorporated in all new bridge designs after 2007.

Interim Specifications are usually published in the middle of the calendar year, and a revised edition of this book is generally published every four years. The Interim Specifications have the same status as AASHTO standards, but are tentative revisions approved by at least two-thirds of the Subcommittee. These revisions are voted on by the AASHTO member departments prior to the publication of each new edition of this book and, if approved by at least two-thirds of the

members, they are included in the new edition as standards of the Association. AASHTO members are the 50 State Highway or Transportation Departments, the District of Columbia, and Puerto Rico. Each member has one vote. The U.S. Department of Transportation is a nonvoting member.

Annual Interim Specifications are generally used by the states after their adoption by the Subcommittee. Orders for these annual Interim Specifications may be placed by visiting our web site, bookstore.transportation.org; calling the AASHTO Publication Sales Office toll free (within the U.S. and Canada), 1-800-231-3475; or mailing to P.O. Box 933538, Atlanta, GA 31193-3538. A free copy of the current publication catalog can be downloaded from our website or requested from the Publications Sales Office.

Attention is also directed to the following publications prepared and published by the Subcommittee on Bridges and Structures:

AASHTO Guide for Commonly Recognized (CoRe) Structural Elements. 1998.

AASHTO Guide Manual for Bridge Element Inspection. 2011.

AASHTO Guide Specifications for Horizontally Curved Steel Girder Highway Bridges with Design Examples for I-Girder and Box-Girder Bridges. 2003. Archived.

AASHTO Guide Specifications—Thermal Effects in Concrete Bridge Superstructures. 1989.

AASHTO LRFD Bridge Construction Specifications. 2010.

AASHTO LRFD Bridge Design Guide Specifications for GFRP-Reinforced Concrete Bridge Decks and Traffic Railings. 2009.

AASHTO LRFD Movable Highway Bridge Design Specifications. 2007.

Bridge Data Exchange (BDX) Technical Data Guide. 1995. Archived.

Bridge Security Guidelines, 2011.

Bridge Welding Code: AASHTO/AWS D1.5M/D1.5:2010, an American National Standard. 2010.

Construction Handbook for Bridge Temporary Works. 1995.

Guide Design Specifications for Bridge Temporary Works. 1995.

Guide for Painting Steel Structures. 1997. Archived.

Guide Manual for Condition Evaluation and Load and Resistance Factor Rating (LRFR) of Highway Bridges. 2003. Archived but download available.

Guide Specifications and Commentary for Vessel Collision Design of Highway Bridges. 2009.

Guide Specifications for Alternate Load Factor Design Procedures for Steel Beam Bridges Using Braced Compact Sections. 1991. Archived.

Guide Specifications for Aluminum Highway Bridges. 1991. Archived.

Guide Specifications for Bridge Railings. 1989. Archived.

Guide Specifications for Design and Construction of Segmental Concrete Bridges. 1999.

Guide Specifications for Fatigue Evaluation of Existing Steel Bridges. 1990. Archived but download available.

Guide Specifications for Highway Bridge Fabrication with HPS 70W (HPS 485W) Steel. 2003.

Guide Specifications for Seismic Isolation Design. 2010.

Guide Specifications for Strength Design of Truss Bridges (Load Factor Design). 1986. Archived but download available.

Guide Specifications for Strength Evaluation of Existing Steel and Concrete Bridges. 1989. Archived but download available.

Guide Specifications for Structural Design of Sound Barriers. 1989. Archived but download available.

Guide Specifications for the Design of Stress-Laminated Wood Decks. 1991. Archived but download available.

Guidelines for Bridge Management Systems. 1993. Archived but download available.

LRFD Guide Specifications for Design of Pedestrian Bridges. 2009.

The Manual for Bridge Evaluation. 2011.

Movable Bridge Inspection, Evaluation, and Maintenance Manual. 1998.

Standard Specifications for Movable Highway Bridges. 1988. Archived but download available.

Standard Specifications for Structural Supports for Highway Signs, Luminaires, and Traffic Signals. 2009.

Technical Manual for Design and Construction of Road Tunnels—Civil Elements. 2010.

Additional bridges and structures publications prepared and published by other AASHTO committees and task forces are as follows:

AASHTO Maintenance Manual: The Maintenance and Management of Roadways and Bridges. 2007.

Guide Specifications for Cathodic Protection of Concrete Bridge Decks. 1994. Archived but download available.

Guide Specifications for Concrete Overlay of Pavements and Bridge Decks. 1990. Archived but download available.

Guide Specifications for Polymer Concrete Bridge Deck Overlays. 1995. Archived but download available.

Guide Specifications for Shotcrete Repair of Highway Bridges. 1998.

Inspector's Guide for Shotcrete Repair of Bridges. 1999.

Manual for Corrosion Protection of Concrete Components in Bridges. 1992. Archived but download available.

The following bridges and structures titles are the result of the AASHTO–NSBA Steel Bridge Collaboration and are available for free download from the AASHTO web site, bookstore.transportation.org:

Design Drawing Presentation Guidelines, G 1.2. 2003.

Guidelines for Design Constructability, G 12.1. 2003.

Guidelines for Design Details, G 1.4. 2006.

Guidelines for Steel Girder Bridge Analysis, G 13.1. 2011.

Guide Specification for Application of Coating Systems with Zinc-Rich Primers to Steel Bridges, S 8.1. 2006.

Recommendations for the Qualification of Structural Bolting Inspectors, G 4.2. 2006.

Sample Owners Quality Assurance Manual, G 4.4. 2006.

Shop Detail Drawing Presentation Guidelines, G 1.3. 2003.

Shop Detail Drawing Review/Approval Guidelines, G 1.1. 2000.

Steel Bridge Bearing Design and Detailing Guidelines, 1st Edition, G 9.1. 2004.

Steel Bridge Erection Guide Specification, S 10.1. 2007.

Steel Bridge Fabrication Guide Specification, S 2.1. 2008.

Steel Bridge Fabrication QC/QA Guide Specification, S 4.1. 2002.

The following have served as chairmen of the Subcommittee on Bridges and Structures since its inception in 1921: Messrs. E. F. Kelley, who pioneered the work of the Subcommittee; Albin L. Gemeny; R. B. McMinn; Raymond Archiband; G. S. Paxson; E. M. Johnson; Ward Goodman; Charles Matlock; Joseph S. Jones; Sidney Poleynard; Jack Freidenrich; Henry W. Derthick; Robert C. Cassano; Clellon Loveall; James E. Siebels; David Pope; Tom Lulay; and Malcolm T. Kerley. The Subcommittee expresses its sincere appreciation of the work of these men and of those active members of the past, whose names, because of retirement, are no longer on the roll.

The Subcommittee would also like to thank Mr. John M. Kulicki, Ph.D., and his associates at Modjeski and Masters for their valuable assistance in the preparation of the LRFD Specifications.

Suggestions for the improvement of the LRFD Specifications are welcomed, just as they were for the Standard Specifications before them. They should be sent to the Chairman, Subcommittee on Bridges and Structures, AASHTO, 444 North Capitol Street, N.W., Suite 249, Washington, DC 20001. Inquiries as to intent or application of the specifications should be sent to the same address.

PREFACE AND ABBREVIATED TABLE OF CONTENTS

The *AASHTO LRFD Bridge Design Specifications*, Sixth Edition contains the following 15 sections and an index:

1. Introduction
 2. General Design and Location Features
 3. Loads and Load Factors
 4. Structural Analysis and Evaluation
 5. Concrete Structures
 6. Steel Structures
 7. Aluminum Structures
 8. Wood Structures
 9. Decks and Deck Systems
 10. Foundations
 11. Abutments, Piers, and Walls
 12. Buried Structures and Tunnel Liners
 13. Railings
 14. Joints and Bearings
 15. Design of Sound Barriers
- Index

Detailed Tables of Contents precede each section. The last article of each section is a list of references displayed alphabetically by author.

Figures, tables, and equations are denoted by their home article number and an extension, for example 1.2.3.4.5-1 wherever they are cited. In early editions, when they were referenced in their home article or its commentary, these objects were identified only by the extension. For example, in Article 1.2.3.4.5, Eq. 1.2.3.4.5-2 would simply have been called “Eq. 2.” The same convention applies to figures and tables. Starting with this edition, these objects are identified by their whole nomenclature throughout the text, even within their home articles. This change was to increase the speed and accuracy of electronic production (i.e., CDs and downloadable files) with regard to linking citations to objects.

Please note that the AASHTO materials standards (starting with M or T) cited throughout the LRFD Specifications can be found in *Standard Specifications for Transportation Materials and Methods of Sampling and Testing*, adopted by the AASHTO Highway Subcommittee on Materials. The individual standards are also available as downloads on the AASHTO Bookstore, <https://bookstore.transportation.org>. Unless otherwise indicated, these citations refer to the current edition. ASTM materials specifications are also cited and have been updated to reflect ASTM’s revised coding system, e.g., spaces removed between the letter and number.

CHANGED AND DELETED ARTICLES, 2012

SUMMARY OF AFFECTED SECTIONS

The revisions included in the *AASHTO LRFD Bridge Design Specifications*, Sixth Edition affect the following sections:

2. General Design and Location Features
3. Loads and Load Factors
4. Structural Analysis and Evaluation
5. Concrete Structures
6. Steel Structures
7. Aluminum Structures
9. Decks and Deck Systems
10. Foundations
11. Abutments, Piers, and Walls
12. Buried Structures and Tunnel Liners
13. Railings
14. Joints and Bearings
15. Design of Sound Barriers

SECTION 2 REVISIONS

Changed Articles

The following Articles in Section 2 contain changes or additions to the specifications, the commentary, or both:

2.5.2.6.3

Deleted Articles

No Articles were deleted from Section 2.

SECTION 3 REVISIONS

Changed Articles

The following Articles in Section 3 contain changes or additions to the specifications, the commentary, or both:

3.3.2	3.6.1.2.5	3.8.1.1	3.10.9.2	3.16
3.4.1	3.6.1.4.1	3.8.1.2.1	3.11.5.10	
3.4.4	3.6.5.1	3.10.2.1	3.15	

Deleted Articles

No Articles were deleted from Section 3.

SECTION 4 REVISIONS

Changed Articles

The following Articles in Section 4 contain changes or additions to the specifications, the commentary, or both:

4.2	4.6.1.2.2	4.6.2.2.3c	4.6.3.2.4
4.6.1.1	4.6.1.2.3	4.6.2.5	4.7.6
4.6.1.2.1	4.6.2.1.8	4.6.2.6.4	4.9

Deleted Articles

No Articles were deleted from Section 4.

SECTION 5 REVISIONS

Changed Articles

The following Articles in Section 5 contain changes or additions to the specifications, the commentary, or both:

5.2	5.7.3.3.2	5.9.4.2.2	5.10.4.3.1c	5.13.2.2
5.3	5.8.1.5	5.10.4.3	5.10.4.3.1d	5.14.2.3.2
5.4.2.6	5.9	5.10.4.3.1	5.10.4.3.2	5.14.2.3.4a
5.5.3.1	5.9.1.1	5.10.4.3.1a	5.10.5	5.14.2.3.4b
5.5.4.2.1	5.9.1.6	5.10.4.3.1b	5.10.9.3.7	5.15

Deleted Articles

5.9.4.3

SECTION 6 REVISIONS

Changed Articles

The following Articles in Section 6 contain changes or additions to the specifications, the commentary, or both:

6.3	6.6.1.3.2	6.10.11.1.3	6.14.3.3	6.16.2
6.5.4.2	6.7.3	6.11.1.1	6.14.3.4	6.16.3
6.5.5	6.7.4.1	6.11.5	6.14.3.2.1	6.16.4
6.6.1.2.1	6.9.4.2.2	6.11.8.2.2	6.14.3.2.2	6.16.4.1
6.6.1.2.3	6.9.4.4	6.11.11.2	6.14.3.2.3	6.16.4.2
6.6.1.2.4	6.10.1.7	6.12.2.2.1	6.14.4.2	6.16.4.3
6.6.1.2.5	6.10.6.2.3	6.14.3	6.16	6.16.4.4
6.6.1.3.1	6.10.10	6.14.3.1	6.16.1	6.17

Deleted Articles

6.14.3.4 6.14.3.5

SECTION 7 REVISIONS

Changed Articles

The following Articles in Section 7 contain changes or additions to the specifications, the commentary, or both:

7.6.1.2.1

Deleted Articles

No Articles were deleted from Section 7.

SECTION 9 REVISIONS

Changed Articles

The following Articles in Section 9 contain changes or additions to the specifications, the commentary, or both:

9.8.3.4	9.8.3.4.3a	9.8.3.6.2	9.8.3.6.2d	9.8.3.7.4
9.8.3.4.1	9.8.3.4.3b	9.8.3.6.2a	9.8.3.7.1	9.10
9.8.3.4.2	9.8.3.4.3c	9.8.3.6.2b	9.8.3.7.2	
9.8.3.4.3	9.8.3.4.4	9.8.3.6.2c	9.8.3.7.3	

Deleted Articles

9.8.3.5	9.8.3.5.2
9.8.3.5.1	9.8.3.5.3

SECTION 10 REVISIONS

Changed Articles

The following Articles in Section 10 contain changes or additions to the specifications, the commentary, or both:

10.6.3.3	10.8.3.6.3
----------	------------

Deleted Articles

No Articles were deleted from Section 10.

SECTION 11 REVISIONS

Changed Articles

The following Articles in Section 11 contain changes or additions to the specifications, the commentary, or both:

11.3.1	11.6.5	11.8.6.1	11.10.6.4.3b	A11.1
11.4.1	11.6.5.1	11.8.6.2	11.10.6.4.4b	A11.2
11.5.3	11.6.5.2	11.8.6.3	11.10.7	A11.3
11.5.4	11.6.5.2.1	11.8.6.4	11.10.7.1	A11.3.1
11.5.4.1	11.6.5.2.2	11.9.6	11.10.7.2	A11.3.2
11.5.4.2	11.6.5.3	11.10.1	11.10.7.3	A11.3.3
11.5.5	11.6.5.4	11.10.2.1	11.10.7.4	A11.4
11.5.6	11.6.5.5	11.10.4.2	11.10.10.1	A11.5
11.5.7	11.6.5.6	11.10.6.3.2	11.11.6	A11.6
11.5.8	11.8.1	11.10.6.4.2a	11.12	
11.6.3.3	11.8.6	11.10.6.4.2b	A11	

Deleted Articles

No Articles were deleted from Section 11.

SECTION 12 REVISIONS

Changed Articles

The following Articles in Section 12 contain changes or additions to the specifications, the commentary, or both:

12.3	12.7.2.2	12.8.9.2.2	12.8.9.4
12.5.5	12.7.2.5	12.8.9.3.1	12.8.9.5
12.6.6.3	12.8.9.1	12.8.9.3.2	12.14.5.6

Deleted Articles

No Articles were deleted from Section 12.

SECTION 13 REVISIONS

Changed Articles

The following Articles in Section 13 contain changes or additions to the specifications, the commentary, or both:

A13.4.3.1

Deleted Articles

No Articles were deleted from Section 13.

SECTION 14 REVISIONS

Changed Articles

The following Articles in Section 14 contain changes or additions to the specifications, the commentary, or both:

14.3	14.7.5.3.3	14.7.6.1	14.7.6.3.3	14.7.6.3.5b
14.6.3.2	14.7.5.3.6	14.7.6.3.2	14.7.6.3.5a	14.7.6.3.6

Deleted Articles

14.7.6.3.5d

SECTION 15

Section 15 is completely new.

AASHTO Publications Staff
January 2012

SECTION 1: INTRODUCTION

TABLE OF CONTENTS

1.1—SCOPE OF THE SPECIFICATIONS 1-1

1.2—DEFINITIONS..... 1-2

1.3—DESIGN PHILOSOPHY 1-3

 1.3.1—General..... 1-3

 1.3.2—Limit States 1-3

 1.3.2.1—General..... 1-3

 1.3.2.2—Service Limit State..... 1-4

 1.3.2.3—Fatigue and Fracture Limit State..... 1-4

 1.3.2.4—Strength Limit State 1-4

 1.3.2.5—Extreme Event Limit States 1-5

 1.3.3—Ductility 1-5

 1.3.4—Redundancy 1-6

 1.3.5—Operational Importance..... 1-7

1.4—REFERENCES..... 1-7

SECTION 1

INTRODUCTION

1.1—SCOPE OF THE SPECIFICATIONS

The provisions of these Specifications are intended for the design, evaluation, and rehabilitation of both fixed and movable highway bridges. Mechanical, electrical, and special vehicular and pedestrian safety aspects of movable bridges, however, are not covered. Provisions are not included for bridges used solely for railway, rail-transit, or public utilities. For bridges not fully covered herein, the provisions of these Specifications may be applied, as augmented with additional design criteria where required.

These Specifications are not intended to supplant proper training or the exercise of judgment by the Designer, and state only the minimum requirements necessary to provide for public safety. The Owner or the Designer may require the sophistication of design or the quality of materials and construction to be higher than the minimum requirements.

The concepts of safety through redundancy and ductility and of protection against scour and collision are emphasized.

The design provisions of these Specifications employ the Load and Resistance Factor Design (LRFD) methodology. The factors have been developed from the theory of reliability based on current statistical knowledge of loads and structural performance.

Methods of analysis other than those included in previous Specifications and the modeling techniques inherent in them are included, and their use is encouraged.

Seismic design shall be in accordance with either the provisions in these Specifications or those given in the *AASHTO Guide Specifications for LRFD Seismic Bridge Design*.

The commentary is not intended to provide a complete historical background concerning the development of these or previous Specifications, nor is it intended to provide a detailed summary of the studies and research data reviewed in formulating the provisions of the Specifications. However, references to some of the research data are provided for those who wish to study the background material in depth.

The commentary directs attention to other documents that provide suggestions for carrying out the requirements and intent of these Specifications. However, those documents and this commentary are not intended to be a part of these Specifications.

Construction specifications consistent with these design specifications are the *AASHTO LRFD Bridge Construction Specifications*. Unless otherwise specified, the Materials Specifications referenced herein are the *AASHTO Standard Specifications for Transportation Materials and Methods of Sampling and Testing*.

C1.1

The term “notional” is often used in these Specifications to indicate an idealization of a physical phenomenon, as in “notional load” or “notional resistance.” Use of this term strengthens the separation of an engineer's “notion” or perception of the physical world in the context of design from the physical reality itself.

The term “shall” denotes a requirement for compliance with these Specifications.

The term “should” indicates a strong preference for a given criterion.

The term “may” indicates a criterion that is usable, but other local and suitably documented, verified, and approved criterion may also be used in a manner consistent with the LRFD approach to bridge design.

1.2—DEFINITIONS

Bridge—Any structure having an opening not less than 20.0 ft that forms part of a highway or that is located over or under a highway.

Collapse—A major change in the geometry of the bridge rendering it unfit for use.

Component—Either a discrete element of the bridge or a combination of elements requiring individual design consideration.

Design—Proportioning and detailing the components and connections of a bridge.

Design Life—Period of time on which the statistical derivation of transient loads is based: 75 yr for these Specifications.

Ductility—Property of a component or connection that allows inelastic response.

Engineer—Person responsible for the design of the bridge and/or review of design-related field submittals such as erection plans.

Evaluation—Determination of load-carrying capacity of an existing bridge.

Extreme Event Limit States—Limit states relating to events such as earthquakes, ice load, and vehicle and vessel collision, with return periods in excess of the design life of the bridge.

Factored Load—The nominal loads multiplied by the appropriate load factors specified for the load combination under consideration.

Factored Resistance—The nominal resistance multiplied by a resistance factor.

Fixed Bridge—A bridge with a fixed vehicular or navigational clearance.

Force Effect—A deformation, stress, or stress resultant (i.e., axial force, shear force, torsional, or flexural moment) caused by applied loads, imposed deformations, or volumetric changes.

Limit State—A condition beyond which the bridge or component ceases to satisfy the provisions for which it was designed.

Load and Resistance Factor Design (LRFD)—A reliability-based design methodology in which force effects caused by factored loads are not permitted to exceed the factored resistance of the components.

Load Factor—A statistically-based multiplier applied to force effects accounting primarily for the variability of loads, the lack of accuracy in analysis, and the probability of simultaneous occurrence of different loads, but also related to the statistics of the resistance through the calibration process.

Load Modifier—A factor accounting for ductility, redundancy, and the operational classification of the bridge.

Model—An idealization of a structure for the purpose of analysis.

Movable Bridge—A bridge with a variable vehicular or navigational clearance.

Multiple-Load-Path Structure—A structure capable of supporting the specified loads following loss of a main load-carrying component or connection.

Nominal Resistance—Resistance of a component or connection to force effects, as indicated by the dimensions specified in the contract documents and by permissible stresses, deformations, or specified strength of materials.

Owner—Person or agency having jurisdiction over the bridge.

Regular Service—Condition excluding the presence of special permit vehicles, wind exceeding 55 mph, and extreme events, including scour.

Rehabilitation—A process in which the resistance of the bridge is either restored or increased.

Resistance Factor—A statistically-based multiplier applied to nominal resistance accounting primarily for variability of material properties, structural dimensions and workmanship, and uncertainty in the prediction of resistance, but also related to the statistics of the loads through the calibration process.

Service Life—The period of time that the bridge is expected to be in operation.

Service Limit States—Limit states relating to stress, deformation, and cracking under regular operating conditions.

Strength Limit States—Limit states relating to strength and stability during the design life.

1.3—DESIGN PHILOSOPHY

1.3.1—General

Bridges shall be designed for specified limit states to achieve the objectives of constructibility, safety, and serviceability, with due regard to issues of inspectability, economy, and aesthetics, as specified in Article 2.5.

Regardless of the type of analysis used, Eq. 1.3.2.1-1 shall be satisfied for all specified force effects and combinations thereof.

1.3.2—Limit States

1.3.2.1—General

Each component and connection shall satisfy Eq. 1.3.2.1-1 for each limit state, unless otherwise specified. For service and extreme event limit states, resistance factors shall be taken as 1.0, except for bolts, for which the provisions of Article 6.5.5 shall apply, and for concrete columns in Seismic Zones 2, 3, and 4, for which the provisions of Articles 5.10.11.3 and 5.10.11.4.1b shall apply. All limit states shall be considered of equal importance.

$$\sum \eta_i \gamma_i Q_i \leq \phi R_n = R_r \quad (1.3.2.1-1)$$

in which:

For loads for which a maximum value of γ_i is appropriate:

$$\eta_i = \eta_D \eta_R \eta_I \geq 0.95 \quad (1.3.2.1-2)$$

For loads for which a minimum value of γ_i is appropriate:

$$\eta_i = \frac{1}{\eta_D \eta_R \eta_I} \leq 1.0 \quad (1.3.2.1-3)$$

C1.3.1

The limit states specified herein are intended to provide for a buildable, serviceable bridge, capable of safely carrying design loads for a specified lifetime.

The resistance of components and connections is determined, in many cases, on the basis of inelastic behavior, although the force effects are determined by using elastic analysis. This inconsistency is common to most current bridge specifications as a result of incomplete knowledge of inelastic structural action.

C1.3.2.1

Eq. 1.3.2.1-1 is the basis of LRFD methodology.

Assigning resistance factor $\phi = 1.0$ to all nonstrength limit states is a default, and may be over-ridden by provisions in other Sections.

Ductility, redundancy, and operational classification are considered in the load modifier η . Whereas the first two directly relate to physical strength, the last concerns the consequences of the bridge being out of service. The grouping of these aspects on the load side of Eq. 1.3.2.1-1 is, therefore, arbitrary. However, it constitutes a first effort at codification. In the absence of more precise information, each effect, except that for fatigue and fracture, is estimated as ± 5 percent, accumulated geometrically, a clearly subjective approach. With time, improved quantification of ductility, redundancy, and operational classification, and their interaction with system reliability, may be attained, possibly leading to a rearrangement of Eq. 1.3.2.1-1, in which these effects may appear on either side of the equation or on both sides.

where:

- γ_i = load factor: a statistically based multiplier applied to force effects
- ϕ = resistance factor: a statistically based multiplier applied to nominal resistance, as specified in Sections 5, 6, 7, 8, 10, 11, and 12
- η_i = load modifier: a factor relating to ductility, redundancy, and operational classification
- η_D = a factor relating to ductility, as specified in Article 1.3.3
- η_R = a factor relating to redundancy as specified in Article 1.3.4
- η_I = a factor relating to operational classification as specified in Article 1.3.5
- Q_i = force effect
- R_n = nominal resistance
- R_r = factored resistance: ϕR_n

1.3.2.2—Service Limit State

The service limit state shall be taken as restrictions on stress, deformation, and crack width under regular service conditions.

1.3.2.3—Fatigue and Fracture Limit State

The fatigue limit state shall be taken as restrictions on stress range as a result of a single design truck occurring at the number of expected stress range cycles.

The fracture limit state shall be taken as a set of material toughness requirements of the AASHTO Materials Specifications.

1.3.2.4—Strength Limit State

Strength limit state shall be taken to ensure that strength and stability, both local and global, are provided to resist the specified statistically significant load combinations that a bridge is expected to experience in its design life.

The influence of η on the girder reliability index, β , can be estimated by observing its effect on the minimum values of β calculated in a database of girder-type bridges. Cellular structures and foundations were not a part of the database; only individual member reliability was considered. For discussion purposes, the girder bridge data used in the calibration of these Specifications was modified by multiplying the total factored loads by $\eta = 0.95, 1.0, 1.05, \text{ and } 1.10$. The resulting minimum values of β for 95 combinations of span, spacing, and type of construction were determined to be approximately 3.0, 3.5, 3.8, and 4.0, respectively. In other words, using $\eta > 1.0$ relates to a β higher than 3.5.

A further approximate representation of the effect of η values can be obtained by considering the percent of random normal data less than or equal to the mean value plus $\lambda \sigma$, where λ is a multiplier, and σ is the standard deviation of the data. If λ is taken as 3.0, 3.5, 3.8, and 4.0, the percent of values less than or equal to the mean value plus $\lambda \sigma$ would be about 99.865 percent, 99.977 percent, 99.993 percent, and 99.997 percent, respectively.

The Strength I Limit State in the *AASHTO LRFD Design Specifications* has been calibrated for a target reliability index of 3.5 with a corresponding probability of exceedance of $2.0E-04$ during the 75-yr design life of the bridge. This 75-yr reliability is equivalent to an annual probability of exceedance of $2.7E-06$ with a corresponding annual target reliability index of 4.6. Similar calibration efforts for the Service Limit States are underway. Return periods for extreme events are often based on annual probability of exceedance and caution must be used when comparing reliability indices of various limit states.

C1.3.2.2

The service limit state provides certain experience-related provisions that cannot always be derived solely from strength or statistical considerations.

C1.3.2.3

The fatigue limit state is intended to limit crack growth under repetitive loads to prevent fracture during the design life of the bridge.

C1.3.2.4

The strength limit state considers stability or yielding of each structural element. If the resistance of any element, including splices and connections, is exceeded, it is assumed that the bridge resistance has been exceeded. In fact, in multigirder cross-sections there is significant elastic reserve capacity in almost all such bridges beyond such a load level. The live load cannot be positioned to maximize the force effects on all parts of the cross-section

1.3.2.5—Extreme Event Limit States

The extreme event limit state shall be taken to ensure the structural survival of a bridge during a major earthquake or flood, or when collided by a vessel, vehicle, or ice flow, possibly under scoured conditions.

1.3.3—Ductility

The structural system of a bridge shall be proportioned and detailed to ensure the development of significant and visible inelastic deformations at the strength and extreme event limit states before failure.

Energy-dissipating devices may be substituted for conventional ductile earthquake resisting systems and the associated methodology addressed in these Specifications or in the *AASHTO Guide Specifications for Seismic Design of Bridges*.

For the strength limit state:

$$\begin{aligned} \eta_D &\geq 1.05 \text{ for nonductile components and connections} \\ &= 1.00 \text{ for conventional designs and details} \\ &\quad \text{complying with these Specifications} \\ &\geq 0.95 \text{ for components and connections for which} \\ &\quad \text{additional ductility-enhancing measures have} \\ &\quad \text{been specified beyond those required by these} \\ &\quad \text{Specifications} \end{aligned}$$

For all other limit states:

$$\eta_D = 1.00$$

simultaneously. Thus, the flexural resistance of the bridge cross-section typically exceeds the resistance required for the total live load that can be applied in the number of lanes available. Extensive distress and structural damage may occur under strength limit state, but overall structural integrity is expected to be maintained.

C1.3.2.5

Extreme event limit states are considered to be unique occurrences whose return period may be significantly greater than the design life of the bridge.

C1.3.3

The response of structural components or connections beyond the elastic limit can be characterized by either brittle or ductile behavior. Brittle behavior is undesirable because it implies the sudden loss of load-carrying capacity immediately when the elastic limit is exceeded. Ductile behavior is characterized by significant inelastic deformations before any loss of load-carrying capacity occurs. Ductile behavior provides warning of structural failure by large inelastic deformations. Under repeated seismic loading, large reversed cycles of inelastic deformation dissipate energy and have a beneficial effect on structural survival.

If, by means of confinement or other measures, a structural component or connection made of brittle materials can sustain inelastic deformations without significant loss of load-carrying capacity, this component can be considered ductile. Such ductile performance shall be verified by testing.

In order to achieve adequate inelastic behavior the system should have a sufficient number of ductile members and either:

- Joints and connections that are also ductile and can provide energy dissipation without loss of capacity; or
- Joints and connections that have sufficient excess strength so as to assure that the inelastic response occurs at the locations designed to provide ductile, energy absorbing response.

Statically ductile, but dynamically nonductile response characteristics should be avoided. Examples of this behavior are shear and bond failures in concrete members and loss of composite action in flexural components.

Past experience indicates that typical components designed in accordance with these provisions generally exhibit adequate ductility. Connection and joints require special attention to detailing and the provision of load paths.

The Owner may specify a minimum ductility factor as an assurance that ductile failure modes will be obtained. The factor may be defined as:

$$\mu = \frac{\Delta_u}{\Delta_y} \quad (\text{C1.3.3-1})$$

where:

Δ_u = deformation at ultimate

Δ_y = deformation at the elastic limit

The ductility capacity of structural components or connections may either be established by full- or large-scale testing or with analytical models based on documented material behavior. The ductility capacity for a structural system may be determined by integrating local deformations over the entire structural system.

The special requirements for energy dissipating devices are imposed because of the rigorous demands placed on these components.

1.3.4—Redundancy

Multiple-load-path and continuous structures should be used unless there are compelling reasons not to use them.

For the strength limit state:

$$\begin{aligned} \eta_R &\geq 1.05 \text{ for nonredundant members} \\ &= 1.00 \text{ for conventional levels of redundancy,} \\ &\quad \text{foundation elements where } \phi \text{ already accounts for} \\ &\quad \text{redundancy as specified in Article 10.5} \\ &\geq 0.95 \text{ for exceptional levels of redundancy beyond} \\ &\quad \text{girder continuity and a torsionally-closed cross-} \\ &\quad \text{section} \end{aligned}$$

C1.3.4

For each load combination and limit state under consideration, member redundancy classification (redundant or nonredundant) should be based upon the member contribution to the bridge safety. Several redundancy measures have been proposed (Frangopol and Nakib, 1991).

Single-cell boxes and single-column bents may be considered nonredundant at the Owner's discretion. For prestressed concrete boxes, the number of tendons in each web should be taken into consideration. For steel cross-sections and fracture-critical considerations, see Section 6.

The Manual for Bridge Evaluation (2008) defines bridge redundancy as "the capability of a bridge structural system to carry loads after damage to or the failure of one or more of its members." System factors are provided for post-tensioned segmental concrete box girder bridges in Appendix E of the Guide Manual.

System reliability encompasses redundancy by considering the system of interconnected components and members. Rupture or yielding of an individual component may or may not mean collapse or failure of the whole structure or system (Nowak, 2000). Reliability indices for

For all other limit states:

$$\eta_R = 1.00$$

1.3.5—Operational Importance

This Article shall apply to the strength and extreme event limit states only.

The Owner may declare a bridge or any structural component and connection thereof to be of operational priority.

For the strength limit state:

$$\begin{aligned} \eta_I &\geq 1.05 \text{ for critical or essential bridges} \\ &= 1.00 \text{ for typical bridges} \\ &\geq 0.95 \text{ for relatively less important bridges.} \end{aligned}$$

For all other limit states:

$$\eta_I = 1.00$$

1.4—REFERENCES

AASHTO. 2010. *AASHTO LRFD Bridge Construction Specifications*, Third Edition with Interims, LRFDCONS-3-M. American Association of State Highway and Transportation Officials, Washington, DC.

AASHTO. 2011. *AASHTO Guide Specifications for LRFD Seismic Bridge Design*, Second Edition, LRFDSEIS-2. American Association of State Highway and Transportation Officials, Washington, DC.

AASHTO. 2011. *The Manual for Bridge Evaluation*, Second Edition with Interim, MBE-2-M. American Association of State Highway and Transportation Officials, Washington, DC.

AASHTO. 2011. *Standard Specifications for Transportation Materials and Methods of Sampling and Testing*, 31th Edition, HM-31. American Association of State Highway and Transportation Officials, Washington, DC.

Frangopol, D. M., and R. Nakib. 1991. "Redundancy in Highway Bridges." *Engineering Journal*, American Institute of Steel Construction, Chicago, IL, Vol. 28, No. 1, pp. 45–50.

entire systems are a subject of ongoing research and are anticipated to encompass ductility, redundancy, and member correlation.

C1.3.5

Such classification should be done by personnel responsible for the affected transportation network and knowledgeable of its operational needs. The definition of operational priority may differ from Owner to Owner and network to network. Guidelines for classifying critical or essential bridges are as follows:

- Bridges that are required to be open to all traffic once inspected after the design event and are usable by emergency vehicles and for security, defense, economic, or secondary life safety purposes immediately after the design event.
- Bridges that should, as a minimum, be open to emergency vehicles and for security, defense, or economic purposes after the design event, and open to all traffic within days after that event.

Owner-classified bridges may use a value for $\eta < 1.0$ based on ADTT, span length, available detour length, or other rationale to use less stringent criteria.

Mertz, D. 2009. "Quantification of Structural Safety of Highway Bridges" (white paper), *Annual Probability of Failure*. Internal communication.

Nowak, A., and K. R. Collins. 2000. *Reliability of Structures*. McGraw-Hill Companies, Inc., New York, NY.

SECTION 2: GENERAL DESIGN AND LOCATION FEATURES

TABLE OF CONTENTS

2.1—SCOPE 2-1

2.2—DEFINITIONS 2-1

2.3—LOCATION FEATURES 2-3

 2.3.1—Route Location 2-3

 2.3.1.1—General 2-3

 2.3.1.2—Waterway and Floodplain Crossings 2-3

 2.3.2—Bridge Site Arrangement 2-4

 2.3.2.1—General 2-4

 2.3.2.2—Traffic Safety 2-4

 2.3.2.2.1—Protection of Structures 2-4

 2.3.2.2.2—Protection of Users 2-5

 2.3.2.2.3—Geometric Standards 2-5

 2.3.2.2.4—Road Surfaces 2-5

 2.3.2.2.5—Vessel Collisions 2-5

 2.3.3—Clearances 2-6

 2.3.3.1—Navigational 2-6

 2.3.3.2—Highway Vertical 2-6

 2.3.3.3—Highway Horizontal 2-6

 2.3.3.4—Railroad Overpass 2-6

 2.3.4—Environment 2-7

2.4—FOUNDATION INVESTIGATION 2-7

 2.4.1—General 2-7

 2.4.2—Topographic Studies 2-7

2.5—DESIGN OBJECTIVES 2-7

 2.5.1—Safety 2-7

 2.5.2—Serviceability 2-8

 2.5.2.1—Durability 2-8

 2.5.2.1.1—Materials 2-8

 2.5.2.1.2—Self-Protecting Measures 2-8

 2.5.2.2—Inspectability 2-9

 2.5.2.3—Maintainability 2-9

 2.5.2.4—Rideability 2-9

 2.5.2.5—Utilities 2-9

 2.5.2.6—Deformations 2-10

 2.5.2.6.1—General 2-10

 2.5.2.6.2—Criteria for Deflection 2-11

 2.5.2.6.3—Optional Criteria for Span-to-Depth Ratios 2-13

 2.5.2.7—Consideration of Future Widening 2-14

 2.5.2.7.1—Exterior Beams on Multibeam Bridges 2-14

2.5.2.7.2—Substructure	2-14
2.5.3—Constructibility	2-14
2.5.4—Economy	2-15
2.5.4.1—General	2-15
2.5.4.2—Alternative Plans	2-15
2.5.5—Bridge Aesthetics	2-16
2.6—HYDROLOGY AND HYDRAULICS	2-17
2.6.1—General	2-17
2.6.2—Site Data	2-18
2.6.3—Hydrologic Analysis	2-18
2.6.4—Hydraulic Analysis	2-19
2.6.4.1—General	2-19
2.6.4.2—Stream Stability	2-19
2.6.4.3—Bridge Waterway	2-20
2.6.4.4—Bridge Foundations	2-20
2.6.4.4.1—General	2-20
2.6.4.4.2—Bridge Scour	2-21
2.6.4.5—Roadway Approaches to Bridge	2-23
2.6.5—Culvert Location, Length, and Waterway Area	2-23
2.6.6—Roadway Drainage	2-24
2.6.6.1—General	2-24
2.6.6.2—Design Storm	2-24
2.6.6.3—Type, Size, and Number of Drains	2-24
2.6.6.4—Discharge from Deck Drains	2-25
2.6.6.5—Drainage of Structures	2-25
2.7—BRIDGE SECURITY	2-25
2.7.1—General	2-25
2.7.2—Design Demand	2-26
2.8—REFERENCES	2-26

GENERAL DESIGN AND LOCATION FEATURES

2.1—SCOPE

Minimum requirements are provided for clearances, environmental protection, aesthetics, geological studies, economy, rideability, durability, constructibility, inspectability, and maintainability. Minimum requirements for traffic safety are referenced.

Minimum requirements for drainage facilities and self-protecting measures against water, ice, and water-borne salts are included.

In recognition that many bridge failures have been caused by scour, hydrology and hydraulics are covered in detail.

2.2—DEFINITIONS

Aggradation—A general and progressive buildup or raising of the longitudinal profile of the channel bed as a result of sediment deposition.

Check Flood for Bridge Scour—Check flood for scour. The flood resulting from storm, storm surge, and/or tide having a flow rate in excess of the design flood for scour, but in no case a flood with a recurrence interval exceeding the typically used 500 yr. The check flood for bridge scour is used in the investigation and assessment of a bridge foundation to determine whether the foundation can withstand that flow and its associated scour and remain stable with no reserve. See also superflood.

Clear Zone—An unobstructed, relatively flat area beyond the edge of the traveled way for the recovery of errant vehicles. The traveled way does not include shoulders or auxiliary lanes.

Clearance—An unobstructed horizontal or vertical space.

Degradation—A general and progressive lowering of the longitudinal profile of the channel bed as a result of long-term erosion.

Design Discharge—Maximum flow of water a bridge is expected to accommodate without exceeding the adopted design constraints.

Design Flood for Bridge Scour—The flood flow equal to or less than the 100-yr flood that creates the deepest scour at bridge foundations. The highway or bridge may be inundated at the stage of the design flood for bridge scour. The worst-case scour condition may occur for the overtopping flood as a result of the potential for pressure flow.

Design Flood for Waterway Opening—The peak discharge, volume, stage, or wave crest elevation and its associated probability of exceedence that are selected for the design of a highway or bridge over a watercourse or floodplain. By definition, the highway or bridge will not be inundated at the stage of the design flood for the waterway opening.

Detention Basin—A storm water management facility that impounds runoff and temporarily discharges it through a hydraulic outlet structure to a downstream conveyance system.

Drip Groove—Linear depression in the bottom of components to cause water flowing on the surface to drop.

Five-Hundred-Year Flood—The flood due to storm and/or tide having a 0.2 percent chance of being equaled or exceeded in any given year.

General or Contraction Scour—Scour in a channel or on a floodplain that is not localized at a pier or other obstruction to flow. In a channel, general/contraction scour usually affects all or most of the channel width and is typically caused by a contraction of the flow.

Hydraulics—The science concerned with the behavior and flow of liquids, especially in pipes and channels.

C2.1

This Section is intended to provide the Designer with sufficient information to determine the configuration and overall dimensions of a bridge.

Hydrology—The science concerned with the occurrence, distribution, and circulation of water on the earth, including precipitation, runoff, and groundwater.

Local Scour—Scour in a channel or on a floodplain that is localized at a pier, abutment, or other obstruction to flow.

Mixed Population Flood—Flood flows derived from two or more causative factors, e.g., a spring tide driven by hurricane-generated onshore winds or rainfall on a snowpack.

One-Hundred-Year Flood—The flood due to storm and/or tide having a 1 percent chance of being equaled or exceeded in any given year.

Overtopping Flood—The flood flow that, if exceeded, results in flow over a highway or bridge, over a watershed divide, or through structures provided for emergency relief. The worst-case scour condition may be caused by the overtopping flood.

Relief Bridge—An opening in an embankment on a floodplain to permit passage of overbank flow.

River Training Structure—Any configuration constructed in a stream or placed on, adjacent to, or in the vicinity of a streambank to deflect current, induce sediment deposition, induce scour, or in some other way alter the flow and sediment regimens of the stream.

Scupper—A device to drain water through the deck.

Sidewalk Width—Unobstructed space for exclusive pedestrian use between barriers or between a curb and a barrier.

Spring Tide—A tide of increased range that occurs about every two weeks when the moon is full or new.

Stable Channel—A condition that exists when a stream has a bed slope and cross-section that allows its channel to transport the water and sediment delivered from the upstream watershed without significant degradation, aggradation, or bank erosion.

Stream Geomorphology—The study of a stream and its floodplain with regard to its land forms, the general configuration of its surface, and the changes that take place due to erosion and the buildup of erosional debris.

Superelevation—A tilting of the roadway surface to partially counterbalance the centrifugal forces on vehicles on horizontal curves.

Superflood—Any flood or tidal flow with a flow rate greater than that of the 100-yr flood but not greater than a 500-yr flood.

Tide—The periodic rise and fall of the earth's ocean that results from the effect of the moon and sun acting on a rotating earth.

Watershed—An area confined by drainage divides, and often having only one outlet for discharge; the total drainage area contributing runoff to a single point.

Waterway—Any stream, river, pond, lake, or ocean.

Waterway Opening—Width or area of bridge opening at a specified stage, and measured normal to principal direction of flow.

2.3—LOCATION FEATURES

2.3.1—Route Location

2.3.1.1—General

The choice of location of bridges shall be supported by analyses of alternatives with consideration given to economic, engineering, social, and environmental concerns as well as costs of maintenance and inspection associated with the structures and with the relative importance of the above-noted concerns.

Attention, commensurate with the risk involved, shall be directed toward providing for favorable bridge locations that:

- Fit the conditions created by the obstacle being crossed;
- Facilitate practical cost effective design, construction, operation, inspection and maintenance;
- Provide for the desired level of traffic service and safety; and
- Minimize adverse highway impacts.

2.3.1.2—Waterway and Floodplain Crossings

Waterway crossings shall be located with regard to initial capital costs of construction and the optimization of total costs, including river channel training works and the maintenance measures necessary to reduce erosion. Studies of alternative crossing locations should include assessments of:

- The hydrologic and hydraulic characteristics of the waterway and its floodplain, including channel stability, flood history, and, in estuarine crossings, tidal ranges and cycles;
- The effect of the proposed bridge on flood flow patterns and the resulting scour potential at bridge foundations;
- The potential for creating new or augmenting existing flood hazards; and
- Environmental impacts on the waterway and its floodplain.

Bridges and their approaches on floodplains should be located and designed with regard to the goals and objectives of floodplain management, including:

- Prevention of uneconomic, hazardous, or incompatible use and development of floodplains;

C2.3.1.2

Detailed guidance on procedures for evaluating the location of bridges and their approaches on floodplains is contained in Federal Regulations and the Planning and Location Chapter of the AASHTO *Model Drainage Manual* (see Commentary on Article 2.6.1). Engineers with knowledge and experience in applying the guidance and procedures in the AASHTO *Model Drainage Manual* should be involved in location decisions. It is generally safer and more cost effective to avoid hydraulic problems through the selection of favorable crossing locations than to attempt to minimize the problems at a later time in the project development process through design measures.

Experience at existing bridges should be part of the calibration or verification of hydraulic models, if possible. Evaluation of the performance of existing bridges during past floods is often helpful in selecting the type, size, and location of new bridges.

- Avoidance of significant transverse and longitudinal encroachments, where practicable;
- Minimization of adverse highway impacts and mitigation of unavoidable impacts, where practicable;
- Consistency with the intent of the standards and criteria of the National Flood Insurance Program, where applicable;
- Long-term aggradation or degradation; and
- Commitments made to obtain environmental approvals.

2.3.2—Bridge Site Arrangement

2.3.2.1—General

The location and the alignment of the bridge should be selected to satisfy both on-bridge and under-bridge traffic requirements. Consideration should be given to possible future variations in alignment or width of the waterway, highway, or railway spanned by the bridge.

Where appropriate, consideration should be given to future addition of mass-transit facilities or bridge widening.

C2.3.2.1

Although the location of a bridge structure over a waterway is usually determined by other considerations than the hazards of vessel collision, the following preferences should be considered where possible and practical:

- Locating the bridge away from bends in the navigation channel. The distance to the bridge should be such that vessels can line up before passing the bridge, usually eight times the length of the vessel. This distance should be increased further where high currents and winds are prevalent at the site.
- Crossing the navigation channel near right angles and symmetrically with respect to the navigation channel.
- Providing an adequate distance from locations with congested navigation, vessel berthing maneuvers or other navigation problems.
- Locating the bridge where the waterway is shallow or narrow and the bridge piers could be located out of vessel reach.

2.3.2.2—Traffic Safety

2.3.2.2.1—Protection of Structures

Consideration shall be given to safe passage of vehicles on or under a bridge. The hazard to errant vehicles within the clear zone should be minimized by locating obstacles at a safe distance from the travel lanes.

C2.3.2.2.1

Pier columns or walls for grade separation structures should be located in conformance with the clear zone concept as contained in Chapter 3 of the AASHTO *Roadside Design Guide*, 1996. Where the practical limits of structure costs, type of structure, volume and design speed of through traffic, span arrangement, skew, and terrain make conformance with the AASHTO *Roadside Design Guide* impractical, the pier or wall should be protected by the use of guardrail or other barrier devices. The guardrail or other device should, if practical, be independently supported, with its roadway face at least 2.0 ft. from the face of pier or abutment, unless a rigid barrier is provided.

The face of the guardrail or other device should be at least 2.0 ft. outside the normal shoulder line.

2.3.2.2.2—Protection of Users

Railings shall be provided along the edges of structures conforming to the requirements of Section 13.

All protective structures shall have adequate surface features and transitions to safely redirect errant traffic.

In the case of movable bridges, warning signs, lights, signal bells, gates, barriers, and other safety devices shall be provided for the protection of pedestrian, cyclists, and vehicular traffic. These shall be designed to operate before the opening of the movable span and to remain operational until the span has been completely closed. The devices shall conform to the requirements for “Traffic Control at Movable Bridges,” in the *Manual on Uniform Traffic Control Devices* or as shown on plans.

Where specified by the Owner, sidewalks shall be protected by barriers.

2.3.2.2.3—Geometric Standards

Requirements of the AASHTO publication *A Policy on Geometric Design of Highways and Streets* shall either be satisfied or exceptions thereto shall be justified and documented. Width of shoulders and geometry of traffic barriers shall meet the specifications of the Owner.

2.3.2.2.4—Road Surfaces

Road surfaces on a bridge shall be given antiskid characteristics, crown, drainage, and superelevation in accordance with *A Policy on Geometric Design of Highways and Streets* or local requirements.

2.3.2.2.5—Vessel Collisions

Bridge structures shall either be protected against vessel collision forces by fenders, dikes, or dolphins as specified in Article 3.14.15, or shall be designed to withstand collision force effects as specified in Article 3.14.14.

The intent of providing structurally independent barriers is to prevent transmission of force effects from the barrier to the structure to be protected.

C2.3.2.2.2

Protective structures include those that provide a safe and controlled separation of traffic on multimodal facilities using the same right-of-way.

Special conditions, such as curved alignment, impeded visibility, etc., may justify barrier protection, even with low design velocities.

C2.3.2.2.5

The need for dolphin and fender systems can be eliminated at some bridges by judicious placement of bridge piers. Guidance on use of dolphin and fender systems is included in the AASHTO *Highway Drainage Guidelines*, Volume 7; *Hydraulic Analyses for the Location and Design of Bridges*; and the AASHTO *Guide Specification and Commentary for Vessel Collision Design of Highway Bridges*.

2.3.3—Clearances

2.3.3.1—Navigational

Permits for construction of a bridge over navigable waterways shall be obtained from the U.S. Coast Guard and/or other agencies having jurisdiction. Navigational clearances, both vertical and horizontal, shall be established in cooperation with the U.S. Coast Guard.

2.3.3.2—Highway Vertical

The vertical clearance of highway structures shall be in conformance with the AASHTO publication *A Policy on Geometric Design of Highways and Streets* for the Functional Classification of the Highway or exceptions thereto shall be justified. Possible reduction of vertical clearance, due to settlement of an overpass structure, shall be investigated. If the expected settlement exceeds 1.0 in., it shall be added to the specified clearance.

The vertical clearance to sign supports and pedestrian overpasses should be 1.0 ft. greater than the highway structure clearance, and the vertical clearance from the roadway to the overhead cross bracing of through-truss structures should not be less than 17.5 ft.

2.3.3.3—Highway Horizontal

The bridge width shall not be less than that of the approach roadway section, including shoulders or curbs, gutters, and sidewalks.

Horizontal clearance under a bridge should meet the requirements of Article 2.3.2.2.1.

No object on or under a bridge, other than a barrier, should be located closer than 4.0 ft. to the edge of a designated traffic lane. The inside face of a barrier should not be closer than 2.0 ft. to either the face of the object or the edge of a designated traffic lane.

2.3.3.4—Railroad Overpass

Structures designed to pass over a railroad shall be in accordance with standards established and used by the affected railroad in its normal practice. These overpass structures shall comply with applicable federal, state, county, and municipal laws.

Regulations, codes, and standards should, as a minimum, meet the specifications and design standards of the American Railway Engineering and Maintenance of Way Association (AREMA), the Association of American Railroads, and AASHTO.

C2.3.3.1

Where bridge permits are required, early coordination should be initiated with the U.S. Coast Guard to evaluate the needs of navigation and the corresponding location and design requirements for the bridge.

Procedures for addressing navigational requirements for bridges, including coordination with the Coast Guard, are set forth in the Code of Federal Regulations, 23 CFR, Part 650, Subpart H, "Navigational Clearances for Bridges," and 33 U.S.C. 401, 491, 511, et seq.

C2.3.3.2

The specified minimum clearance should include 6.0 in. for possible future overlays. If overlays are not contemplated by the Owner, this requirement may be nullified.

Sign supports, pedestrian bridges, and overhead cross bracings require the higher clearance because of their lesser resistance to impact.

C2.3.3.3

The usable width of the shoulders should generally be taken as the paved width.

The specified minimum distances between the edge of the traffic lane and fixed object are intended to prevent collision with slightly errant vehicles and those carrying wide loads.

C2.3.3.4

Attention is particularly called to the following chapters in the *Manual for Railway Engineering* (AREMA, 2003):

- Chapter 7—Timber Structures,
- Chapter 8—Concrete Structures and Foundations,
- Chapter 9—Highway-Railroad Crossings,
- Chapter 15— Steel Structures, and
- Chapter 18—Clearances.

The provisions of the individual railroads and the AREMA Manual should be used to determine:

- Clearances,
- Loadings,
- Pier protection,
- Waterproofing, and
- Blast protection.

2.3.4—Environment

The impact of a bridge and its approaches on local communities, historic sites, wetlands, and other aesthetically, environmentally, and ecologically sensitive areas shall be considered. Compliance with state water laws; federal and state regulations concerning encroachment on floodplains, fish, and wildlife habitats; and the provisions of the National Flood Insurance Program shall be assured. Stream geomorphology, consequences of riverbed scour, removal of embankment stabilizing vegetation, and, where appropriate, impacts to estuarine tidal dynamics shall be considered.

2.4—FOUNDATION INVESTIGATION

2.4.1—General

A subsurface investigation, including borings and soil tests, shall be conducted in accordance with the provisions of Article 10.4 to provide pertinent and sufficient information for the design of substructure units. The type and cost of foundations should be considered in the economic and aesthetic studies for location and bridge alternate selection.

2.4.2—Topographic Studies

Current topography of the bridge site shall be established via contour maps and photographs. Such studies shall include the history of the site in terms of movement of earth masses, soil and rock erosion, and meandering of waterways.

2.5—DESIGN OBJECTIVES

2.5.1—Safety

The primary responsibility of the Engineer shall be providing for the safety of the public.

C2.3.4

Stream, i.e., fluvial, geomorphology is a study of the structure and formation of the earth's features that result from the forces of water. For purposes of this Section, this involves evaluating the streams, potential for aggradation, degradation, or lateral migration.

C2.5.1

Minimum requirements to ensure the structural safety of bridges as conveyances are included in these Specifications. The philosophy of achieving adequate structural safety is outlined in Article 1.3. It is recommended that an approved QC/QA review and checking process be utilized to ensure that the design work meets these Specifications.

2.5.2—Serviceability

2.5.2.1—Durability

2.5.2.1.1—Materials

The contract documents shall call for quality materials and for the application of high standards of fabrication and erection.

Structural steel shall be self-protecting, or have long-life coating systems or cathodic protection.

Reinforcing bars and prestressing strands in concrete components, which may be expected to be exposed to airborne or waterborne salts, shall be protected by an appropriate combination of epoxy and/or galvanized coating, concrete cover, density, or chemical composition of concrete, including air-entrainment and a nonporous painting of the concrete surface or cathodic protection.

Prestress strands in cable ducts shall be grouted or otherwise protected against corrosion.

Attachments and fasteners used in wood construction shall be of stainless steel, malleable iron, aluminum, or steel that is galvanized, cadmium-plated, or otherwise coated. Wood components shall be treated with preservatives.

Aluminum products shall be electrically insulated from steel and concrete components.

Protection shall be provided to materials susceptible to damage from solar radiation and/or air pollution.

Consideration shall be given to the durability of materials in direct contact with soil and/or water.

2.5.2.1.2—Self-Protecting Measures

Continuous drip grooves shall be provided along the underside of a concrete deck at a distance not exceeding 10.0 in. from the fascia edges. Where the deck is interrupted by a sealed deck joint, all surfaces of piers and abutments, other than bearing seats, shall have a minimum slope of 5 percent toward their edges. For open deck joints, this minimum slope shall be increased to 15 percent. In the case of open deck joints, the bearings shall be protected against contact with salt and debris.

Wearing surfaces shall be interrupted at the deck joints and shall be provided with a smooth transition to the deck joint device.

Steel formwork shall be protected against corrosion in accordance with the specifications of the Owner.

C2.5.2.1.1

The intent of this Article is to recognize the significance of corrosion and deterioration of structural materials to the long-term performance of a bridge. Other provisions regarding durability can be found in Article 5.12.

Other than the deterioration of the concrete deck itself, the single most prevalent bridge maintenance problem is the disintegration of beam ends, bearings, pedestals, piers, and abutments due to percolation of waterborne road salts through the deck joints. Experience appears to indicate that a structurally continuous deck provides the best protection for components below the deck. The potential consequences of the use of road salts on structures with unfilled steel decks and unstressed wood decks should be taken into account.

These Specifications permit the use of discontinuous decks in the absence of substantial use of road salts. Transverse saw-cut relief joints in cast-in-place concrete decks have been found to be of no practical value where composite action is present. Economy, due to structural continuity and the absence of expansion joints, will usually favor the application of continuous decks, regardless of location.

Stringers made simply supported by sliding joints, with or without slotted bolt holes, tend to “freeze” due to the accumulation of corrosion products and cause maintenance problems. Because of the general availability of computers, analysis of continuous decks is no longer a problem.

Experience indicates that, from the perspective of durability, all joints should be considered subject to some degree of movement and leakage.

C2.5.2.1.2

Ponding of water has often been observed on the seats of abutments, probably as a result of construction tolerances and/or tilting. The 15 percent slope specified in conjunction with open joints is intended to enable rains to wash away debris and salt.

In the past, for many smaller bridges, no expansion device was provided at the “fixed joint,” and the wearing surface was simply run over the joint to give a continuous riding surface. As the rotation center of the superstructure is always below the surface, the “fixed joint” actually moves due to load and environmental effects, causing the wearing surface to crack, leak, and disintegrate.

2.5.2.2—Inspectability

Inspection ladders, walkways, catwalks, covered access holes, and provision for lighting, if necessary, shall be provided where other means of inspection are not practical.

Where practical, access to permit manual or visual inspection, including adequate headroom in box sections, shall be provided to the inside of cellular components and to interface areas, where relative movement may occur.

2.5.2.3—Maintainability

Structural systems whose maintenance is expected to be difficult should be avoided. Where the climatic and/or traffic environment is such that a bridge deck may need to be replaced before the required service life, provisions shall be shown on the contract documents for:

- a contemporary or future protective overlay,
- a future deck replacement, or
- supplemental structural resistance.

Areas around bearing seats and under deck joints should be designed to facilitate jacking, cleaning, repair, and replacement of bearings and joints.

Jacking points shall be indicated on the plans, and the structure shall be designed for jacking forces specified in Article 3.4.3. Inaccessible cavities and corners should be avoided. Cavities that may invite human or animal inhabitants shall either be avoided or made secure.

2.5.2.4—Rideability

The deck of the bridge shall be designed to permit the smooth movement of traffic. On paved roads, a structural transition slab should be located between the approach roadway and the abutment of the bridge. Construction tolerances, with regard to the profile of the finished deck, shall be indicated on the plans or in the specifications or special provisions.

The number of deck joints shall be kept to a practical minimum. Edges of joints in concrete decks exposed to traffic should be protected from abrasion and spalling. The plans for prefabricated joints shall specify that the joint assembly be erected as a unit.

Where concrete decks without an initial overlay are used, consideration should be given to providing an additional thickness of 0.5 in. to permit correction of the deck profile by grinding, and to compensate for thickness loss due to abrasion.

2.5.2.5—Utilities

Where required, provisions shall be made to support and maintain the conveyance for utilities.

C2.5.2.2

The *Guide Specifications for Design and Construction of Segmental Concrete Bridges* requires external access hatches with a minimum size of 2.5 ft. × 4.0 ft., larger openings at interior diaphragms, and venting by drains or screened vents at intervals of no more than 50.0 ft. These recommendations should be used in bridges designed under these Specifications.

C2.5.2.3

Maintenance of traffic during replacement should be provided either by partial width staging of replacement or by the utilization of an adjacent parallel structure.

Measures for increasing the durability of concrete and wood decks include epoxy coating of reinforcing bars, post-tensioning ducts, and prestressing strands in the deck. Microsilica and/or calcium nitrite additives in the deck concrete, waterproofing membranes, and overlays may be used to protect black steel. See Article 5.14.2.3.10e for additional requirements regarding overlays.

2.5.2.6—Deformations

2.5.2.6.1—General

Bridges should be designed to avoid undesirable structural or psychological effects due to their deformations. While deflection and depth limitations are made optional, except for orthotropic plate decks, any large deviation from past successful practice regarding slenderness and deflections should be cause for review of the design to determine that it will perform adequately.

If dynamic analysis is used, it shall comply with the principles and requirements of Article 4.7.

For straight skewed steel girder bridges and horizontally curved steel girder bridges with or without skewed supports, the following additional investigations shall be considered:

- Elastic vertical, lateral, and rotational deflections due to applicable load combinations shall be considered to ensure satisfactory service performance of bearings, joints, integral abutments, and piers.

C2.5.2.6.1

Service load deformations may cause deterioration of wearing surfaces and local cracking in concrete slabs and in metal bridges that could impair serviceability and durability, even if self-limiting and not a potential source of collapse.

As early as 1905, attempts were made to avoid these effects by limiting the depth-to-span ratios of trusses and girders, and starting in the 1930s, live load deflection limits were prescribed for the same purpose. In a study of deflection limitations of bridges (ASCE, 1958), an ASCE committee found numerous shortcomings in these traditional approaches and noted, for example:

The limited survey conducted by the Committee revealed no evidence of serious structural damage that could be attributed to excessive deflection. The few examples of damaged stringer connections or cracked concrete floors could probably be corrected more effectively by changes in design than by more restrictive limitations on deflection. On the other hand, both the historical study and the results from the survey indicate clearly that unfavorable psychological reaction to bridge deflection is probably the most frequent and important source of concern regarding the flexibility of bridges. However, those characteristics of bridge vibration which are considered objectionable by pedestrians or passengers in vehicles cannot yet be defined.

Since publication of the study, there has been extensive research on human response to motion. It is now generally agreed that the primary factor affecting human sensitivity is acceleration, rather than deflection, velocity, or the rate of change of acceleration for bridge structures, but the problem is a difficult subjective one. Thus, there are as yet no simple definitive guidelines for the limits of tolerable static deflection or dynamic motion. Among current specifications, the *Ontario Highway Bridge Design Code* of 1991 contains the most comprehensive provisions regarding vibrations tolerable to humans.

Horizontally curved steel bridges are subjected to torsion resulting in larger lateral deflections and twisting than tangent bridges. Therefore, rotations due to dead load and thermal forces tend to have a larger effect on the performance of bearings and expansion joints of curved bridges.

Bearing rotations during construction may exceed the dead load rotations computed for the completed bridge, in particular at skewed supports. Identification of this temporary situation may be critical to ensure the bridge can be built without damaging the bearings or expansion devices.

- Computed girder rotations at bearings should be accumulated over the Engineer's assumed construction sequence. Computed rotations at bearings shall not exceed the specified rotational capacity of the bearings for the accumulated factored loads corresponding to the stage investigated.
- Camber diagrams shall satisfy the provisions of Article 6.7.2 and may reflect the computed accumulated deflections due to the Engineer's assumed construction sequence.

2.5.2.6.2—Criteria for Deflection

The criteria in this Section shall be considered optional, except for the following:

- The provisions for orthotropic decks shall be considered mandatory.
- The provisions in Article 12.14.5.9 for precast reinforced concrete three-sided structures shall be considered mandatory.
- Metal grid decks and other lightweight metal and concrete bridge decks shall be subject to the serviceability provisions of Article 9.5.2.

In applying these criteria, the vehicular load shall include the dynamic load allowance.

If an Owner chooses to invoke deflection control, the following principles may be applied:

- When investigating the maximum absolute deflection for straight girder systems, all design lanes should be loaded, and all supporting components should be assumed to deflect equally;
- For curved steel box and I-girder systems, the deflection of each girder should be determined individually based on its response as part of a system;
- For composite design, the stiffness of the design cross-section used for the determination of deflection should include the entire width of the roadway and the structurally continuous portions of the railings, sidewalks, and median barriers;

C2.5.2.6.2

These provisions permit, but do not encourage, the use of past practice for deflection control. Designers were permitted to exceed these limits at their discretion in the past. Calculated deflections of structures have often been found to be difficult to verify in the field due to numerous sources of stiffness not accounted for in calculations. Despite this, many Owners and designers have found comfort in the past requirements to limit the overall stiffness of bridges. The desire for continued availability of some guidance in this area, often stated during the development of these Specifications, has resulted in the retention of optional criteria, except for orthotropic decks, for which the criteria are required. Deflection criteria are also mandatory for lightweight decks comprised of metal and concrete, such as filled and partially filled grid decks, and unfilled grid decks composite with reinforced concrete slabs, as provided in Article 9.5.2.

Additional guidance regarding deflection of steel bridges can be found in Wright and Walker (1971).

Additional considerations and recommendations for deflection in timber bridge components are discussed in more detail in Chapters 7, 8, and 9 in Ritter (1990).

For a straight multibeam bridge, this is equivalent to saying that the distribution factor for deflection is equal to the number of lanes divided by the number of beams.

For curved steel girder systems, the deflection limit is applied to each individual girder because the curvature causes each girder to deflect differently than the adjacent girder so that an average deflection has little meaning. For curved steel girder systems, the span used to compute the deflection limit should be taken as the arc girder length between bearings.

- For straight girder systems, the composite bending stiffness of an individual girder may be taken as the stiffness determined as specified above, divided by the number of girders;
- When investigating maximum relative displacements, the number and position of loaded lanes should be selected to provide the worst differential effect;
- The live load portion of Load Combination Service I of Table 3.4.1-1 should be used, including the dynamic load allowance, IM;
- The live load shall be taken from Article 3.6.1.3.2;
- The provisions of Article 3.6.1.1.2 should apply; and
- For skewed bridges, a right cross-section may be used, and for curved and curved skewed bridges, a radial cross-section may be used.

In the absence of other criteria, the following deflection limits may be considered for steel, aluminum, and/or concrete vehicular bridges:

- Vehicular load, general Span/800,
- Vehicular and pedestrian loads Span/1000,
- Vehicular load on cantilever arms
Span/300, and
- Vehicular and pedestrian loads on cantilever arms
Span/375.

For steel I-shaped beams and girders, and for steel box and tub girders, the provisions of Articles 6.10.4.2 and 6.11.4, respectively, regarding the control of permanent deflections through flange stress controls, shall apply. For pedestrian bridges, i.e., bridges whose primary function is to carry pedestrians, bicyclists, equestrians, and light maintenance vehicles, the provisions of Section 5 of AASHTO’s *LRFD Guide Specifications for the Design of Pedestrian Bridges* shall apply.

In the absence of other criteria, the following deflection limits may be considered for wood construction:

- Vehicular and pedestrian loads Span/425, and
- Vehicular load on wood planks and panels (extreme relative deflection between adjacent edges). 0.10 in.

The following provisions shall apply to orthotropic plate decks:

- Vehicular load on deck plate Span/300,
- Vehicular load on ribs of orthotropic metal decks
Span/1000, and

From a structural viewpoint, large deflections in wood components cause fasteners to loosen and brittle materials, such as asphalt pavement, to crack and break. In addition, members that sag below a level plane present a poor appearance and can give the public a perception of structural inadequacy. Deflections from moving vehicle loads also produce vertical movement and vibrations that annoy motorists and alarm pedestrians (Ritter, 1990).

Excessive deformation can cause premature deterioration of the wearing surface and affect the performance of fasteners, but limits on the latter have not yet been established.

The intent of the relative deflection criterion is to protect the wearing surface from debonding and fracturing due to excessive flexing of the deck.

- Vehicular load on ribs of orthotropic metal decks (extreme relative deflection between adjacent ribs) 0.10 in.

The 0.10-in. relative deflection limitation is tentative.

2.5.2.6.3—Optional Criteria for Span-to-Depth Ratios

C2.5.2.6.3

Unless otherwise specified herein, if an Owner chooses to invoke controls on span-to-depth ratios, the limits in Table 2.5.2.6.3-1, in which S is the slab span length and L is the span length, both in ft., may be considered in the absence of other criteria. Where used, the limits in Table 2.5.2.6.3-1 shall be taken to apply to overall depth unless noted.

Traditional minimum depths for constant depth superstructures, contained in previous editions of the AASHTO *Standard Specifications for Highway Bridges*, are given in Table 2.5.2.6.3-1 with some modifications.

For curved steel girder systems, the span-to-depth ratio, L_{as}/D , of each steel girder should not exceed 25 when the specified minimum yield strength of the girder in regions of positive flexure is 50.0 ksi or less, and:

A larger preferred minimum girder depth is specified for curved steel girders to reflect the fact that the outermost curved girder receives a disproportionate share of the load and needs to be stiffer. In curved skewed bridges, cross-frame forces are directly related to the relative girder deflections. Increasing the depth and stiffness of all the girders in a curved skewed bridge leads to smaller relative differences in the deflections and smaller cross-frame forces. Deeper girders also result in reduced out-of-plane rotations, which may make the bridge easier to erect.

- When the specified minimum yield strength of the girder is 70.0 ksi or less in regions of negative flexure, or
- When hybrid sections satisfying the provisions of Article 6.10.1.3 are used in regions of negative flexure.

An increase in the preferred minimum girder depth for curved steel girders not satisfying the conditions specified herein is recommended according to Eq. 2.5.2.6.3-1. In such cases, the girders will tend to be significantly more flexible and less steel causes increased deflections without an increase in the girder depth.

For all other curved steel girder systems, L_{as}/D of each steel girder should not exceed the following:

A shallower curved girder might be used if the Engineer evaluates effects such as cross-frame forces and bridge deformations, including girder rotations, and finds the bridge forces and geometric changes within acceptable ranges. For curved composite girders, the recommended ratios apply to the steel girder portion of the composite section.

$$\frac{L_{as}}{D} \leq 25 \sqrt{\frac{50}{F_{yt}}} \quad (2.5.2.6.3-1)$$

where:

F_{yt} = specified minimum yield strength of the compression flange (ksi)

D = depth of steel girder (ft.)

L_{as} = an arc girder length defined as follows (ft.):

- arc span for simple spans;
- 0.9 times the arc span for continuous end-spans;
- 0.8 times the arc span for continuous interior spans.

Table 2.5.2.6.3-1—Traditional Minimum Depths for Constant Depth Superstructures

Superstructure		Minimum Depth (Including Deck)	
		When variable depth members are used, values may be adjusted to account for changes in relative stiffness of positive and negative moment sections	
Material	Type	Simple Spans	Continuous Spans
Reinforced Concrete	Slabs with main reinforcement parallel to traffic	$\frac{1.2 S + 10}{30}$	$\frac{S + 10}{30} \geq 0.54 \text{ ft.}$
	T-Beams	$0.070L$	$0.065L$
	Box Beams	$0.060L$	$0.055L$
	Pedestrian Structure Beams	$0.035L$	$0.033L$
Prestressed Concrete	Slabs	$0.030L \geq 6.5 \text{ in.}$	$0.027L \geq 6.5 \text{ in.}$
	CIP Box Beams	$0.045L$	$0.040L$
	Precast I-Beams	$0.045L$	$0.040L$
	Pedestrian Structure Beams	$0.033L$	$0.030L$
	Adjacent Box Beams	$0.030L$	$0.025L$
Steel	Overall Depth of Composite I-Beam	$0.040L$	$0.032L$
	Depth of I-Beam Portion of Composite I-Beam	$0.033L$	$0.027L$
	Trusses	$0.100L$	$0.100L$

2.5.2.7—Consideration of Future Widening

2.5.2.7.1—Exterior Beams on Multibeam Bridges

Unless future widening is virtually inconceivable, the load carrying capacity of exterior beams shall not be less than the load carrying capacity of an interior beam.

2.5.2.7.2—Substructure

When future widening can be anticipated, consideration should be given to designing the substructure for the widened condition.

2.5.3—Constructibility

Constructability issues should include, but not be limited to, consideration of deflection, strength of steel and concrete, and stability during critical stages of construction.

Bridges should be designed in a manner such that fabrication and erection can be performed without undue difficulty or distress and that locked-in construction force effects are within tolerable limits.

When the designer has assumed a particular sequence of construction in order to induce certain stresses under dead load, that sequence shall be defined in the contract documents.

C2.5.2.7.1

This provision applies to any longitudinal flexural members traditionally considered to be stringers, beams, or girders.

C2.5.3

An example of a particular sequence of construction would be where the designer requires a steel girder to be supported while the concrete deck is cast, so that the girder and the deck will act compositely for dead load as well as live load.

An example of a complex bridge might be a cable-stayed bridge that has limitations on what it will carry, especially in terms of construction equipment, while it is under construction. If these limitations are not evident to an experienced contractor, the contractor may be required to do more prebid analysis than is reasonable. Given the usual constraints of time and budget for bidding, this may not be feasible for the contractor to do.

Where there are, or are likely to be, constraints imposed on the method of construction, by environmental considerations or for other reasons, attention shall be drawn to those constraints in the contract documents.

Where the bridge is of unusual complexity, such that it would be unreasonable to expect an experienced contractor to predict and estimate a suitable method of construction while bidding the project, at least one feasible construction method shall be indicated in the contract documents.

If the design requires some strengthening and/or temporary bracing or support during erection by the selected method, indication of the need thereof shall be indicated in the contract documents.

Details that require welding in restricted areas or placement of concrete through congested reinforcing should be avoided.

Climatic and hydraulic conditions that may affect the construction of the bridge shall be considered.

2.5.4—Economy

2.5.4.1—General

Structural types, span lengths, and materials shall be selected with due consideration of projected cost. The cost of future expenditures during the projected service life of the bridge should be considered. Regional factors, such as availability of material, fabrication, location, shipping, and erection constraints, shall be considered.

2.5.4.2—Alternative Plans

In instances where economic studies do not indicate a clear choice, the Owner may require that alternative contract plans be prepared and bid competitively. Designs for alternative plans shall be of equal safety, serviceability, and aesthetic value.

Movable bridges over navigable waterways should be avoided to the extent feasible. Where movable bridges are proposed, at least one fixed bridge alternative should be included in the economic comparisons.

This Article does not require the designer to educate a contractor on how to construct a bridge; it is expected that the contractor will have the necessary expertise. Nor is it intended to restrict a contractor from using innovation to gain an edge over the competitors.

All other factors being equal, designs that are self-supporting or use standardized falsework systems are normally preferred to those requiring unique and complex falsework.

Temporary falsework within the clear zone should be adequately protected from traffic.

C2.5.4.1

If data for the trends in labor and material cost fluctuation are available, the effect of such trends should be projected to the time the bridge will likely be constructed.

Cost comparisons of structural alternatives should be based on long-range considerations, including inspection, maintenance, repair, and/or replacement. Lowest first cost does not necessarily lead to lowest total cost.

2.5.5—Bridge Aesthetics

Bridges should complement their surroundings, be graceful in form, and present an appearance of adequate strength.

Engineers should seek more pleasant appearance by improving the shapes and relationships of the structural component themselves. The application of extraordinary and nonstructural embellishment should be avoided.

The following guidelines should be considered:

- Alternative bridge designs without piers or with few piers should be studied during the site selection and location stage and refined during the preliminary design stage.
- Pier form should be consistent in shape and detail with the superstructure.
- Abrupt changes in the form of components and structural type should be avoided. Where the interface of different structural types cannot be avoided, a smooth transition in appearance from one type to another should be attained.
- Attention to details, such as deck drain downspouts, should not be overlooked.
- If the use of a through structure is dictated by performance and/or economic considerations, the structural system should be selected to provide an open and uncluttered appearance.
- The use of the bridge as a support for message or directional signing or lighting should be avoided wherever possible.
- Transverse web stiffeners, other than those located at bearing points, should not be visible in elevation.
- For spanning deep ravines, arch-type structures should be preferred.

C2.5.5

Significant improvements in appearance can often be made with small changes in shape or position of structural members at negligible cost. For prominent bridges, however, additional cost to achieve improved appearance is often justified, considering that the bridge will likely be a feature of the landscape for 75 or more years.

Comprehensive guidelines for the appearance of bridges are beyond the scope of these Specifications. Engineers may resort to such documents as the Transportation Research Board's *Bridge Aesthetics Around the World* (1991) for guidance.

The most admired modern structures are those that rely for their good appearance on the forms of the structural component themselves:

- Components are shaped to respond to the structural function. They are thick where the stresses are greatest and thin where the stresses are smaller.
- The function of each part and how the function is performed is visible.
- Components are slender and widely spaced, preserving views through the structure.
- The bridge is seen as a single whole, with all members consistent and contributing to that whole; for example, all elements should come from the same family of shapes, such as shapes with rounded edges.
- The bridge fulfills its function with a minimum of material and minimum number of elements.
- The size of each member compared with the others is clearly related to the overall structural concept and the job the component does, and
- The bridge as a whole has a clear and logical relationship to its surroundings.

Several procedures have been proposed to integrate aesthetic thinking into the design process (Gottemoeller, 1991).

Because the major structural components are the largest parts of a bridge and are seen first, they determine the appearance of a bridge. Consequently, engineers should seek excellent appearance in bridge parts in the following order of importance:

- Horizontal and vertical alignment and position in the environment;
- Superstructure type, i.e., arch, girder, etc.;
- Pier placement;
- Abutment placement and height;
- Superstructure shape, i.e., haunched, tapered, depth;

- Pier shape;
- Abutment shape;
- Parapet and railing details;
- Surface colors and textures; and
- Ornament.

The Designer should determine the likely position of the majority of viewers of the bridge, then use that information as a guide in judging the importance of various elements in the appearance of the structure.

Perspective drawings of photographs taken from the important viewpoints can be used to analyze the appearance of proposed structures. Models are also useful.

The appearance of standard details should be reviewed to make sure they fit the bridge's design concept.

2.6—HYDROLOGY AND HYDRAULICS

2.6.1—General

Hydrologic and hydraulic studies and assessments of bridge sites for stream crossings shall be completed as part of the preliminary plan development. The detail of these studies should be commensurate with the importance of and risks associated with the structure.

Temporary structures for the Contractor's use or for accommodating traffic during construction shall be designed with regard to the safety of the traveling public and the adjacent property owners, as well as minimization of impact on floodplain natural resources. The Owner may permit revised design requirements consistent with the intended service period for, and flood hazard posed by, the temporary structure. Contract documents for temporary structures shall delineate the respective responsibilities and risks to be assumed by the highway agency and the Contractor.

Evaluation of bridge design alternatives shall consider stream stability, backwater, flow distribution, stream velocities, scour potential, flood hazards, tidal dynamics where appropriate and consistency with established criteria for the National Flood Insurance Program.

C2.6.1

The provisions in this Article incorporate improved practices and procedures for the hydraulic design of bridges. Detailed guidance for applying these practices and procedures are contained in the *AASHTO Model Drainage Manual*. This document contains guidance and references on design procedures and computer software for hydrologic and hydraulic design. It also incorporates guidance and references from the *AASHTO Drainage Guidelines*, which is a companion document to the *AASHTO Model Drainage Manual*.

Information on the National Flood Insurance Program is contained in 42 USC 4001-4128, The National Flood Insurance Act (see also 44 CFR 59 through 77) and 23 CFR 650, Subpart A, *Location and Hydraulic Design of Encroachment on Floodplains*.

Hydrologic, hydraulic, scour, and stream stability studies are concerned with the prediction of flood flows and frequencies and with the complex physical processes involving the actions and interactions of water and soil during the occurrence of predicted flood flows. These studies should be performed by the Engineer with the knowledge and experience to make practical judgments regarding the scope of the studies to be performed and the significance of the results obtained. The design of bridge foundations is best accomplished by an interdisciplinary team of structural, hydraulic, and geotechnical engineers.

The *AASHTO Model Drainage Manual* also contains guidance and references on:

- Design methods for evaluating the accuracy of hydraulic studies, including elements of a data collection plan;
- Guidance on estimating flood flow peaks and volumes, including requirements for the design of Interstate highways as per 23 CFR 650, Subpart A,

“Encroachments;”

- Procedures or references for analysis of tidal waterways, regulated streams, and urban watersheds;
- Evaluation of stream stability;
- Use of recommended design procedures and software for sizing bridge waterways;
- Location and design of bridges to resist damage from scour and hydraulic loads created by stream current, ice, and debris;
- Calculation of magnitude of contraction scour, local scour, and countermeasures thereto;
- Design of relief bridges, road overtopping, guide banks, and other river training works; and
- Procedures for hydraulic design of bridge-size culverts.

2.6.2—Site Data

A site-specific data collection plan shall include consideration of:

- Collection of aerial and/or ground survey data for appropriate distances upstream and downstream from the bridge for the main stream channel and its floodplain;
- Estimation of roughness elements for the stream and the floodplain within the reach of the stream under study;
- Sampling of streambed material to a depth sufficient to ascertain material characteristics for scour analysis;
- Subsurface borings;
- Factors affecting water stages, including high water from streams, reservoirs, detention basins, tides, and flood control structures and operating procedures;
- Existing studies and reports, including those conducted in accordance with the provisions of the National Flood Insurance Program or other flood control programs;
- Available historical information on the behavior of the stream and the performance of the structure during past floods, including observed scour, bank erosion, and structural damage due to debris or ice flows; and
- Possible geomorphic changes in channel flow.

2.6.3—Hydrologic Analysis

The Owner shall determine the extent of hydrologic studies on the basis of the functional highway classification, the applicable federal and state requirements, and the flood hazards at the site.

The following flood flows should be investigated, as appropriate, in the hydrologic studies:

C2.6.2

The assessment of hydraulics necessarily involves many assumptions. Key among these assumptions are the roughness coefficients and projection of long-term flow magnitudes, e.g., the 500-yr flood or other superfloods. The runoff from a given storm can be expected to change with the seasons, immediate past weather conditions, and long-term natural and man-made changes in surface conditions. The ability to statistically project long recurrence interval floods is a function of the adequacy of the database of past floods, and such projections often change as a result of new experience.

The above factors make the check flood investigation of scour an important, but highly variable, safety criterion that may be expected to be difficult to reproduce, unless all of the Designer’s original assumptions are used in a post-design scour investigation. Obviously, those original assumptions must be reasonable given the data, conditions, and projections available at the time of the original design.

C2.6.3

The return period of tidal flows should be correlated to the hurricane or storm tide elevations of water as reported in studies by FEMA or other agencies.

Particular attention should be given to selecting design and checking flood discharges for mixed population flood events. For example, flow in an estuary may consist of both

- For assessing flood hazards and meeting floodplain management requirements—the 100-yr flood;
- For assessing risks to highway users and damage to the bridge and its roadway approaches—the overtopping flood and/or the design flood for bridge scour;
- For assessing catastrophic flood damage at high risk sites—a check flood of a magnitude selected by the Owner, as appropriate for the site conditions and the perceived risk;
- For investigating the adequacy of bridge foundations to resist scour—the check flood for bridge scour;
- To satisfy agency design policies and criteria—design floods for waterway opening and bridge scour for the various functional classes of highways;
- To calibrate water surface profiles and to evaluate the performance of existing structures—historical floods, and
- To evaluate environmental conditions—low or base flow information, and in estuarine crossings, the spring and tide range.

Investigation of the effect of sea level rise on tidal ranges should be specified for structures spanning marine/estuarine resources.

2.6.4—Hydraulic Analysis

2.6.4.1—General

The Engineer shall utilize analytical models and techniques that have been approved by the Owner and that are consistent with the required level of analysis.

2.6.4.2—Stream Stability

Studies shall be carried out to evaluate the stability of the waterway and to assess the impact of construction on the waterway. The following items shall be considered:

- Whether the stream reach is degrading, aggrading, or in equilibrium;
- For stream crossing near confluences, the effect of the main stream and the tributary on the flood stages, velocities, flow distribution, vertical, and lateral movements of the stream, and the effect of the foregoing conditions on the hydraulic design of the bridge;
- Location of favorable stream crossing, taking into account whether the stream is straight, meandering, braided, or transitional, or control devices to protect the bridge from existing or anticipated future stream

tidal flow and runoff from the upland watershed.

If mixed population flows are dependent on the occurrence of a major meteorological event, such as a hurricane, the relative timing of the individual peak flow events needs to be evaluated and considered in selecting the design discharge. This is likely to be the case for flows in an estuary.

If the events tend to be independent, as might be the case for floods in a mountainous region caused by rainfall runoff or snow melt, the Designer should evaluate both events independently and then consider the probability of their occurrence at the same time.

conditions;

- The effect of any proposed channel changes;
- The effect of aggregate mining or other operations in the channel;
- Potential changes in the rates or volumes of runoff due to land use changes;
- The effect of natural geomorphic stream pattern changes on the proposed structure; and
- The effect of geomorphic changes on existing structures in the vicinity of, and caused by, the proposed structure.

For unstable streams or flow conditions, special studies shall be carried out to assess the probable future changes to the plan form and profile of the stream and to determine countermeasures to be incorporated in the design, or at a future time, for the safety of the bridge and approach roadways.

2.6.4.3—Bridge Waterway

The design process for sizing the bridge waterway shall include:

- The evaluation of flood flow patterns in the main channel and floodplain for existing conditions, and
- The evaluation of trial combinations of highway profiles, alignments, and bridge lengths for consistency with design objectives.

Where use is made of existing flood studies, their accuracy shall be determined.

2.6.4.4—Bridge Foundations

2.6.4.4.1—General

The structural, hydraulic, and geotechnical aspects of foundation design shall be coordinated and differences resolved prior to approval of preliminary plans.

C2.6.4.3

Trial combinations should take the following into account:

- Increases in flood water surface elevations caused by the bridge,
- Changes in flood flow patterns and velocities in the channel and on the floodplain,
- Location of hydraulic controls affecting flow through the structure or long-term stream stability,
- Clearances between the flood water elevations and low sections of the superstructure to allow passage of ice and debris,
- Need for protection of bridge foundations and stream channel bed and banks, and
- Evaluation of capital costs and flood hazards associated with the candidate bridge alternatives through risk assessment or risk analysis procedures.

C2.6.4.4.1

To reduce the vulnerability of the bridge to damage from scour and hydraulic loads, consideration should be given to the following general design concepts:

- Set deck elevations as high as practical for the given site conditions to minimize inundation by floods. Where bridges are subject to inundation, provide for overtopping of roadway approach sections, and streamline the superstructure to minimize the area subject to hydraulic loads and the collection of ice,

debris, and drifts.

- Utilize relief bridges, guide banks, dikes, and other river training devices to reduce the turbulence and hydraulic forces acting at the bridge abutments.
- Utilize continuous span designs. Anchor superstructures to their substructures where subject to the effects of hydraulic loads, buoyancy, ice, or debris impacts or accumulations. Provide for venting and draining of the superstructure.
- Where practical, limit the number of piers in the channel, streamline pier shapes, and align piers with the direction of flood flows. Avoid pier types that collect ice and debris. Locate piers beyond the immediate vicinity of stream banks.
- Locate abutments back from the channel banks where significant problems with ice/debris buildup, scour, or channel stability are anticipated, or where special environmental or regulatory needs must be met, e.g., spanning wetlands.
- Design piers on floodplains as river piers. Locate their foundations at the appropriate depth if there is a likelihood that the stream channel will shift during the life of the structure or that channel cutoffs are likely to occur.
- Where practical, use debris racks or ice booms to stop debris and ice before it reaches the bridge. Where significant ice or debris buildup is unavoidable, its effects should be accounted for in determining scour depths and hydraulic loads.

2.6.4.4.2—Bridge Scour

As required by Article 3.7.5, scour at bridge foundations is investigated for two conditions:

- For the design flood for scour, the streambed material in the scour prism above the total scour line shall be assumed to have been removed for design conditions. The design flood storm surge, tide, or mixed population flood shall be the more severe of the 100-yr events or from an overtopping flood of lesser recurrence interval.
- For the check flood for scour, the stability of bridge foundation shall be investigated for scour conditions resulting from a designated flood storm surge, tide, or mixed population flood not to exceed the 500-yr event or from an overtopping flood of lesser recurrence interval. Excess reserve beyond that required for stability under this condition is not necessary. The extreme event limit state shall apply.

If the site conditions, due to ice or debris jams, and low tail water conditions near stream confluences dictate the use

C2.6.4.4.2

A majority of bridge failures in the United States and elsewhere are the result of scour.

The added cost of making a bridge less vulnerable to damage from scour is small in comparison to the total cost of a bridge failure.

The design flood for scour shall be determined on the basis of the Engineer's judgment of the hydrologic and hydraulic flow conditions at the site. The recommended procedure is to evaluate scour due to the specified flood flows and to design the foundation for the event expected to cause the deepest total scour.

The recommended procedure for determining the total scour depth at bridge foundations is as follows:

- Estimate the long-term channel profile aggradation or degradation over the service life of the bridge;
- Estimate the long-term channel plan form changes over the service life of the bridge;
- As a design check, adjust the existing channel and floodplain cross-sections upstream and downstream of

of a more severe flood event for either the design or check flood for scour, the Engineer may use such flood event.

Spread footings on soil or erodible rock shall be located so that the bottom of footing is below scour depths determined for the check flood for scour. Spread footings on scour-resistant rock shall be designed and constructed to maintain the integrity of the supporting rock.

Deep foundations with footings shall be designed to place the top of the footing below the estimated contraction scour depth where practical to minimize obstruction to flood flows and resulting local scour. Even lower elevations should be considered for pile-supported footings where the piles could be damaged by erosion and corrosion from exposure to stream currents. Where conditions dictate a need to construct the top of a footing to an elevation above the streambed, attention shall be given to the scour potential of the design.

When fendering or other pier protection systems are used, their effect on pier scour and collection of debris shall be taken into consideration in the design.

bridge as necessary to reflect anticipated changes in the channel profile and plan form;

- Determine the combination of existing or likely future conditions and flood events that might be expected to result in the deepest scour for design conditions;
- Determine water surface profiles for a stream reach that extends both upstream and downstream of the bridge site for the various combinations of conditions and events under consideration;
- Determine the magnitude of contraction scour and local scour at piers and abutments; and
- Evaluate the results of the scour analysis, taking into account the variables in the methods used, the available information on the behavior of the watercourse, and the performance of existing structures during past floods. Also consider present and anticipated future flow patterns in the channel and its floodplain. Visualize the effect of the bridge on these flow patterns and the effect of the flow on the bridge. Modify the bridge design where necessary to satisfy concerns raised by the scour analysis and the evaluation of the channel plan form.

Foundation designs should be based on the total scour depths estimated by the above procedure, taking into account appropriate geotechnical safety factors. Where necessary, bridge modifications may include:

- Relocation or redesign of piers or abutments to avoid areas of deep scour or overlapping scour holes from adjacent foundation elements,
- Addition of guide banks, dikes, or other river training works to provide for smoother flow transitions or to control lateral movement of the channel,
- Enlargement of the waterway area, or
- Relocation of the crossing to avoid an undesirable location.

Foundations should be designed to withstand the conditions of scour for the design flood and the check flood. In general, this will result in deep foundations. The design of the foundations of existing bridges that are being rehabilitated should consider underpinning if scour indicates the need. Riprap and other scour countermeasures may be appropriate if underpinning is not cost effective.

Available technology has not developed sufficiently to provide reliable scour estimates for some conditions, such as bridge abutments located in areas of turbulence due to converging or diverging flows.

The stability of abutments in areas of turbulent flow shall be thoroughly investigated. Exposed embankment slopes should be protected with appropriate scour countermeasures.

2.6.4.5—Roadway Approaches to Bridge

The design of the bridge shall be coordinated with the design of the roadway approaches to the bridge on the floodplain so that the entire flood flow pattern is developed and analyzed as a single, interrelated entity. Where roadway approaches on the floodplain obstruct overbank flow, the highway segment within the floodplain limits shall be designed to minimize flood hazards.

Where diversion of flow to another watershed occurs as a result of backwater and obstruction of flood flows, an evaluation of the design shall be carried out to ensure compliance with legal requirements in regard to flood hazards in the other watershed.

C2.6.4.5

Highway embankments on floodplains serve to redirect overbank flow, causing it to flow generally parallel to the embankment and return to the main channel at the bridge. For such cases, the highway designs shall include countermeasures where necessary to limit damage to highway fills and bridge abutments. Such countermeasures may include:

- Relief bridges,
- Retarding the velocity of the overbank flow by promoting growth of trees and shrubs on the floodplain and highway embankment within the highway right-of-way or constructing small dikes along the highway embankment,
- Protecting fill slopes subject to erosive velocities by use of riprap or other erosion protection materials on highway fills and spill-through abutments, and
- Use of guide banks where overbank flow is large to protect abutments of main channel and relief bridges from turbulence and resulting scour.

Although overtopping may result in failure of the embankment, this consequence is preferred to failure of the bridge. The low point of the overtopping section should not be located immediately adjacent to the bridge, because its failure at this location could cause damage to the bridge abutment. If the low point of the overtopping section must be located close to the abutment, due to geometric constraints, the scouring effect of the overtopping flow should be considered in the design of the abutment. Design studies for overtopping should also include evaluation of any flood hazards created by changes to existing flood flow patterns or by flow concentrations in the vicinity of developed properties.

2.6.5—Culvert Location, Length, and Waterway Area

In addition to the provisions of Articles 2.6.3 and 2.6.4, the following conditions should be considered:

- Passage of fish and wildlife,
- Effect of high outlet velocities and flow concentrations on the culvert outlet, the downstream channel, and adjacent property,
- Buoyancy effects at culvert inlets,
- Traffic safety, and
- The effects of high tail water conditions as may be caused by downstream controls or storm tides.

C2.6.5

The discussion of site investigations and hydrologic and hydraulic analyses for bridges is generally applicable to large culvert installations classified as bridges.

The use of safety grates on culvert ends to protect vehicles that run off the road is generally discouraged for large culverts, including those classified as bridges, because of the potential for clogging and subsequent unexpected increase in the flood hazard to the roadway and adjacent properties. Preferred methods of providing for traffic safety include the installation of barriers or the extension of the culvert ends to increase the vehicle recovery zone at the site.

2.6.6—Roadway Drainage

2.6.6.1—General

The bridge deck and its highway approaches shall be designed to provide safe and efficient conveyance of surface runoff from the traveled way in a manner that minimizes damage to the bridge and maximizes the safety of passing vehicles. Transverse drainage of the deck, including roadway, bicycle paths, and pedestrian walkways, shall be achieved by providing a cross slope or superelevation sufficient for positive drainage. For wide bridges with more than three lanes in each direction, special design of bridge deck drainage and/or special rough road surfaces may be needed to reduce the potential for hydroplaning. Water flowing downgrade in the roadway gutter section shall be intercepted and not permitted to run onto the bridge. Drains at bridge ends shall have sufficient capacity to carry all contributing runoff.

In those unique environmentally sensitive instances where it is not possible to discharge into the underlying watercourse, consideration should be given to conveying the water in a longitudinal storm drain affixed to the underside of the bridge and discharging it into appropriate facilities on natural ground at bridge end.

2.6.6.2—Design Storm

The design storm for bridge deck drainage shall not be less than the storm used for design of the pavement drainage system of the adjacent roadway, unless otherwise specified by the Owner.

2.6.6.3—Type, Size, and Number of Drains

The number of deck drains should be kept to a minimum consistent with hydraulic requirements.

In the absence of other applicable guidance, for bridges where the highway design speed is less than 45 mph, the size and number of deck drains should be such that the spread of deck drainage does not encroach on more than one-half the width of any designated traffic lane. For bridges where the highway design speed is not less than 45 mph, the spread of deck drainage should not encroach on any portion of the designated traffic lanes. Gutter flow should be intercepted at cross slope transitions to prevent flow across the bridge deck.

Scuppers or inlets of a deck drain shall be hydraulically efficient and accessible for cleaning.

C2.6.6.1

Where feasible, bridge decks should be watertight and all of the deck drainage should be carried to the ends of the bridge.

A longitudinal gradient on bridges should be maintained. Zero gradients and sag vertical curves should be avoided. Design of the bridge deck and the approach roadway drainage systems should be coordinated.

Under certain conditions, open bridge railings may be desirable for maximum discharge of surface runoff from bridge decks.

The “Storm Drainage” chapter of the AASHTO *Model Drainage Manual* contains guidance on recommended values for cross slopes.

C2.6.6.3

For further guidance or design criteria on bridge deck drainage, see the “Storm Drainage” chapter of the AASHTO *Model Drainage Manual*, *Policy on Geometric Design of Highways and Streets*, and AASHTO/FHWA Research Report RD-87-014, *Bridge Deck Drainage Guidelines*.

The minimum internal dimension of a downspout should not normally be less than 6.0 in., but not less than 8.0 in. where ice accretion on the bridge deck is expected.

2.6.6.4—Discharge from Deck Drains

Deck drains shall be designed and located such that surface water from the bridge deck or road surface is directed away from the bridge superstructure elements and the substructure.

If the Owner has no specific requirements for controlling the effluent from drains and pipes, consideration should be given to:

- A minimum 4.0-in. projection below the lowest adjacent superstructure component,
- Location of pipe outlets such that a 45° cone of splash will not touch structural components,
- Use of free drops or slots in parapets wherever practical and permissible,
- Use of bends not greater than 45°, and
- Use of cleanouts.

Runoff from bridge decks and deck drains shall be disposed of in a manner consistent with environmental and safety requirements.

2.6.6.5—Drainage of Structures

Cavities in structures where there is a likelihood for entrapment of water shall be drained at their lowest point. Decks and wearing surfaces shall be designed to prevent the ponding of water, especially at deck joints. For bridge decks with nonintegral wearing surfaces or stay-in-place forms, consideration shall be given to the evacuation of water that may accumulate at the interface.

2.7—BRIDGE SECURITY**2.7.1—General**

An assessment of the priority of a bridge should be conducted during the planning of new bridges and/or during rehabilitation of existing bridges. This should take into account the social/economic impact of the loss of the bridge, the availability of alternate routes, and the effect of closing the bridge on the security/defense of the region.

For bridges deemed critical or essential, a formal vulnerability study should be conducted, and measures to mitigate the vulnerabilities should be considered for incorporation into the design.

C2.6.6.4

Consideration should be given to the effect of drainage systems on bridge aesthetics.

For bridges where free drops are not feasible, attention should be given to the design of the outlet piping system to:

- Minimize clogging and other maintenance problems and
- Minimize the intrusive effect of the piping on the bridge symmetry and appearance.

Free drops should be avoided where runoff creates problems with traffic, rail, or shipping lanes. Riprap or pavement should be provided under the free drops to prevent erosion.

C2.6.6.5

Weep holes in concrete decks and drain holes in stay-in-place forms can be used to permit the egress of water.

C2.7.1

At the time of this writing, there are no uniform procedures for assessing the priority of a bridge to the social/economic and defense/security of a region. Work is being done to produce a uniform procedure to prioritize bridges for security.

In the absence of uniform procedures, some states have developed procedures that incorporate their own security prioritization methods which, while similar, differ in details. In addition, procedures to assess bridge priority were developed by departments of transportation in some states to assist in prioritizing seismic rehabilitation. The procedures established for assessing bridge priority may also be used in conjunction with security considerations.

Guidance on security strategies and risk reduction may be found in the following documents: Science Applications International Corporation (2002), The Blue Ribbon Panel on Bridge and Tunnel Security (2003), Winget (2003), Jenkins (2001), Abramson (1999), and Williamson (2006).

2.7.2—Design Demand

Bridge Owners should establish criteria for the size and location of the threats to be considered in the analysis of bridges for security. These criteria should take into account the type, geometry, and priority of the structure being considered. The criteria should also consider multi-tier threat sizes and define the associated level of structural performance for each tier.

Design demands should be determined from analysis of a given size design threat, taking into account the associated performance levels. Given the demands, a design strategy should be developed and approved by the Bridge Owner.

2.8—REFERENCES

AASHTO. 2009. *Guide Specification and Commentary for Vessel Collision Design of Highway Bridges*, Second Edition with Interim Revisions, GVCB-2-M. American Association State Highway and Transportation Officials, Washington, DC.

AASHTO. 2005. *Model Drainage Manual*, Third Edition, MDM-3. American Association of State Highway and Transportation Officials, Washington, DC.

AASHTO. 2011. *Roadside Design Guide*, RSDG-4. American Association of State Highway and Transportation Officials, Washington, DC.

AASHTO and FHWA. 1987. *Bridge Deck Drainage Guidelines*, Research Report RD-87-014. American Association of State Highway and Transportation Officials/Federal Highway Administration, Washington, DC.

Abramson, H. N., et al. 1999. *Improving Surface Transportation Security: A Research and Development Strategy*. Committee on R & D Strategies to Improve Surface Transportation Security, National Research Council, National Academy Press, Washington, DC.

AREMA. 2003. *Manual for Railway Engineering*. American Railway Engineers Association, Washington, DC.

ASCE. 1958. "Deflection Limitations of Bridges: Progress Report of the Committee on Deflection Limitations of Bridges of the Structural Division." *Journal of the Structural Division*, American Society of Civil Engineers, New York, NY, Vol. 84, No. ST 3, May 1958.

The Blue Ribbon Panel on Bridge and Tunnel Security. 2003. *Recommendations for Bridge and Tunnel Security*. Special report prepared for FHWA and AASHTO, Washington, DC.

FHWA. 1991. "Evaluating Scour at Bridges," FHWA-IP-90-017. *Hydraulic Engineering Circular 18*. Federal Highway Administration, U.S. Department of Transportation, Washington, DC.

C2.7.2

It is not possible to protect a bridge from every conceivable threat. The most likely threat scenarios should be determined based on the bridge structural system and geometry and the identified vulnerabilities. The most likely attack scenarios will minimize the attacker's required time on target, possess simplicity in planning and execution, and have a high probability of achieving maximum damage.

The level of acceptable damage should be proportionate to the size of the attack. For example, linear behavior and/or local damage should be expected under a small-size attack, while significant permanent deformations and significant damage and/or partial failure of some components should be acceptable under larger size attacks.

The level of threat and the operational classification of the bridge should be taken into account when determining the level of analysis to be used in determining the demands. Approximate methods may be used for low-force, low-importance bridges, while more sophisticated analyses should be used for high-force threats to priority bridges.

FHWA. 1991. "Stream Stability at Highway Structures," FHWA-1P-90-014. *Hydraulic Engineering Circular 20*. Federal Highway Administration, U.S. Department of Transportation, Washington, DC.

Gottemoeller, F. 1991. "Aesthetics and Engineers: Providing for Aesthetic Quality in Bridge Design." *Bridge Aesthetics Around the World*, Transportation Research Board, National Research Council, Washington, DC, pp. 80–88.
Highway Engineering Division. 1991. *Ontario Highway Bridge Design Code*, Highway Engineering Division, Ministry of Transportation and Communications, Toronto, Canada.

Jenkins, B. M. 2001. *Protecting Public Surface Transportation Against Terrorism and Serious Crime: An Executive Overview*. MTI Report 01-14. Mineta Transportation Institute, San Jose, CA. Available at <http://transweb.sjsu.edu/mtiportal/research/publications/summary/0114.html>.

Location and Hydraulic Design of Encroachment on Floodplains, U.S. Code, 23 CFR 650, Subpart A, U.S. Government Printing Office, Washington, DC.

National Flood Insurance Act, U.S. Code, Title 42, Secs. 4001–28, U.S. Government Printing Office, Washington, DC.

NRC. 1991. *Bridge Aesthetics around the World*, Transportation Research Board, National Research Council, Washington, DC.

Ritter, M. A. 1990. *Timber Bridges, Design, Construction, Inspection, and Maintenance*, EM7700-B. Forest Service, U.S. Department of Agriculture, Washington, DC.

Science Applications International Corporation (SAIC), Transportation Policy and Analysis Center. 2002. *A Guide to Highway Vulnerability Assessment for Critical Asset Identification and Protection*. Report prepared for The American Association of State Highway and Transportation Officials' Security Task Force, Washington, DC. Available at http://security.transportation.org/sites/security/docs/guide-VA_FinalReport.pdf.

Williamson, E. B., D. G. Winget, J. C. Gannon, and K. A. Marchand. 2006. *Design of Critical Bridges for Security Against Terrorist Attacks: Phase II*. Pooled Fund Project TPF-5(056) Final Report. University of Texas, Austin, TX.

Winget, D. G., and E. B. Williamson. 2003. *Design of Critical Bridges for Security Against Terrorist Attacks*. TXDOT Project No. 0-4569, Phase 1 Report. University of Texas, Austin, TX.

Wright, R. N., and W. H. Walker. 1971. "Criteria for the Deflection of Steel Bridges," *AISI Bulletin*, No. 19, November 1971, Washington, DC.

SECTION 3: LOADS AND LOAD FACTORS

TABLE OF CONTENTS

3.1—SCOPE 3-1

3.2—DEFINITIONS 3-1

3.3—NOTATION 3-3

 3.3.1—General 3-3

 3.3.2—Load and Load Designation 3-7

3.4—LOAD FACTORS AND COMBINATIONS 3-8

 3.4.1—Load Factors and Load Combinations 3-8

 3.4.2—Load Factors for Construction Loads 3-15

 3.4.2.1—Evaluation at the Strength Limit State 3-15

 3.4.2.2—Evaluation of Deflection at the Service Limit State 3-15

 3.4.3—Load Factors for Jacking and Post-Tensioning Forces 3-16

 3.4.3.1—Jacking Forces 3-16

 3.4.3.2—Force for Post-Tensioning Anchorage Zones 3-16

 3.4.4—Load Factors for Orthotropic Decks 3-16

3.5—PERMANENT LOADS 3-16

 3.5.1—Dead Loads: *DC*, *DW*, and *EV* 3-16

 3.5.2—Earth Loads: *EH*, *ES*, and *DD* 3-17

3.6—LIVE LOADS 3-17

 3.6.1—Gravity Loads: *LL* and *PL* 3-17

 3.6.1.1—Vehicular Live Load 3-17

 3.6.1.1.1—Number of Design Lanes 3-17

 3.6.1.1.2—Multiple Presence of Live Load 3-18

 3.6.1.2—Design Vehicular Live Load 3-19

 3.6.1.2.1—General 3-19

 3.6.1.2.2—Design Truck 3-23

 3.6.1.2.3—Design Tandem 3-24

 3.6.1.2.4—Design Lane Load 3-24

 3.6.1.2.5—Tire Contact Area 3-24

 3.6.1.2.6—Distribution of Wheel Loads through Earth Fills 3-25

 3.6.1.3—Application of Design Vehicular Live Loads 3-25

 3.6.1.3.1—General 3-25

 3.6.1.3.2—Loading for Optional Live Load Deflection Evaluation 3-26

 3.6.1.3.3—Design Loads for Decks, Deck Systems, and the Top Slabs of Box Culverts 3-27

 3.6.1.3.4—Deck Overhang Load 3-28

 3.6.1.4—Fatigue Load 3-28

 3.6.1.4.1—Magnitude and Configuration 3-28

 3.6.1.4.2—Frequency 3-28

 3.6.1.4.3—Load Distribution for Fatigue 3-29

 3.6.1.4.3a—Refined Methods 3-29

 3.6.1.4.3b—Approximate Methods 3-29

3.6.1.5—Rail Transit Load	3-30
3.6.1.6—Pedestrian Loads	3-30
3.6.1.7—Loads on Railings.....	3-30
3.6.2—Dynamic Load Allowance: <i>IM</i>	3-30
3.6.2.1—General.....	3-30
3.6.2.2—Buried Components.....	3-31
3.6.2.3—Wood Components.....	3-32
3.6.3—Centrifugal Forces: <i>CE</i>	3-32
3.6.4—Braking Force: <i>BR</i>	3-32
3.6.5—Vehicular Collision Force: <i>CT</i>	3-35
3.6.5.1—Protection of Structures.....	3-35
3.6.5.2—Vehicle Collision with Barriers.....	3-36
3.7—WATER LOADS: <i>WA</i>	3-37
3.7.1—Static Pressure	3-37
3.7.2—Buoyancy	3-37
3.7.3—Stream Pressure	3-37
3.7.3.1—Longitudinal	3-37
3.7.3.2—Lateral	3-38
3.7.4—Wave Load	3-39
3.7.5—Change in Foundations Due to Limit State for Scour.....	3-39
3.8—WIND LOAD: <i>WL</i> AND <i>WS</i>	3-39
3.8.1—Horizontal Wind Pressure	3-39
3.8.1.1—General.....	3-39
3.8.1.2—Wind Pressure on Structures: <i>WS</i>	3-41
3.8.1.2.1—General.....	3-41
3.8.1.2.2—Loads from Superstructures	3-41
3.8.1.2.3—Forces Applied Directly to the Substructure	3-42
3.8.1.3—Wind Pressure on Vehicles: <i>WL</i>	3-42
3.8.2—Vertical Wind Pressure.....	3-43
3.8.3—Aeroelastic Instability	3-43
3.8.3.1—General.....	3-43
3.8.3.2—Aeroelastic Phenomena	3-44
3.8.3.3—Control of Dynamic Responses.....	3-44
3.8.3.4—Wind Tunnel Tests.....	3-44
3.9—ICE LOADS: <i>IC</i>	3-44
3.9.1—General	3-44
3.9.2—Dynamic Ice Forces on Piers.....	3-46
3.9.2.1—Effective Ice Strength.....	3-46
3.9.2.2—Crushing and Flexing	3-47
3.9.2.3—Small Streams.....	3-48
3.9.2.4—Combination of Longitudinal and Transverse Forces	3-49
3.9.2.4.1—Piers Parallel to Flow	3-49
3.9.2.4.2—Piers Skewed to Flow.....	3-49

3.9.2.5—Slender and Flexible Piers	3-50
3.9.3—Static Ice Loads on Piers	3-50
3.9.4—Hanging Dams and Ice Jams	3-50
3.9.5—Vertical Forces Due to Ice Adhesion	3-50
3.9.6—Ice Accretion and Snow Loads on Superstructures	3-51
3.10—EARTHQUAKE EFFECTS: <i>EQ</i>	3-52
3.10.1—General	3-52
3.10.2—Seismic Hazard	3-54
3.10.2.1—General Procedure	3-54
3.10.2.2—Site Specific Procedure	3-83
3.10.3—Site Effects	3-84
3.10.3.1—Site Class Definitions	3-84
3.10.3.2—Site Factors	3-88
3.10.4—Seismic Hazard Characterization	3-89
3.10.4.1—Design Response Spectrum	3-89
3.10.4.2—Elastic Seismic Response Coefficient	3-90
3.10.5—Operational Classification	3-90
3.10.6—Seismic Performance Zones	3-91
3.10.7—Response Modification Factors	3-91
3.10.7.1—General	3-91
3.10.7.2—Application	3-92
3.10.8—Combination of Seismic Force Effects	3-92
3.10.9—Calculation of Design Forces	3-93
3.10.9.1—General	3-93
3.10.9.2—Seismic Zone 1	3-93
3.10.9.3—Seismic Zone 2	3-93
3.10.9.4—Seismic Zones 3 and 4	3-94
3.10.9.4.1—General	3-94
3.10.9.4.2—Modified Design Forces	3-94
3.10.9.4.3—Inelastic Hinging Forces	3-94
3.10.9.4.3a—General	3-94
3.10.9.4.3b—Single Columns and Piers	3-95
3.10.9.4.3c—Piers with Two or More Columns	3-96
3.10.9.4.3d—Column and Pile Bent Design Forces	3-97
3.10.9.4.3e—Pier Design Forces	3-97
3.10.9.4.3f—Foundation Design Forces	3-97
3.10.9.5—Longitudinal Restrainers	3-98
3.10.9.6—Hold-Down Devices	3-98
3.10.10—Requirements for Temporary Bridges and Stage Construction	3-98
3.11—EARTH PRESSURE: <i>EH, ES, LS, AND DD</i>	3-99
3.11.1—General	3-99
3.11.2—Compaction	3-100
3.11.3—Presence of Water	3-100
3.11.4—Effect of Earthquake	3-101

3.11.5—Earth Pressure: <i>EH</i>	3-101
3.11.5.1—Lateral Earth Pressure	3-101
3.11.5.2—At-Rest Lateral Earth Pressure Coefficient, k_o	3-102
3.11.5.3—Active Lateral Earth Pressure Coefficient, k_a	3-103
3.11.5.4—Passive Lateral Earth Pressure Coefficient, k_p	3-105
3.11.5.5—Equivalent-Fluid Method of Estimating Rankine Lateral Earth Pressures	3-107
3.11.5.6—Lateral Earth Pressures for Nongravity Cantilevered Walls	3-109
3.11.5.7—Apparent Earth Pressure (<i>AEP</i>) for Anchored Walls	3-113
3.11.5.7.1—Cohesionless Soils	3-113
3.11.5.7.2—Cohesive Soils	3-114
3.11.5.7.2a—Stiff to Hard	3-115
3.11.5.7.2b—Soft to Medium Stiff	3-115
3.11.5.8—Lateral Earth Pressures for Mechanically Stabilized Earth Walls	3-116
3.11.5.8.1—General	3-116
3.11.5.8.2—Internal Stability	3-118
3.11.5.9—Lateral Earth Pressures for Prefabricated Modular Walls	3-118
3.11.6—Surcharge Loads: <i>ES</i> and <i>LS</i>	3-123
3.11.6.1—Uniform Surcharge Loads (<i>ES</i>)	3-123
3.11.6.2—Point, Line, and Strip Loads (<i>ES</i>): Walls Restrained from Movement	3-124
3.11.6.3—Strip Loads (<i>ES</i>): Flexible Walls	3-127
3.11.6.4—Live Load Surcharge (<i>LS</i>)	3-129
3.11.6.5—Reduction of Surcharge	3-130
3.11.7—Reduction Due to Earth Pressure	3-131
3.11.8—Downdrag	3-131
3.12—FORCE EFFECTS DUE TO SUPERIMPOSED DEFORMATIONS: <i>TU</i> , <i>TG</i> , <i>SH</i> , <i>CR</i> , <i>SE</i> , <i>PS</i>	3-133
3.12.1—General	3-133
3.12.2—Uniform Temperature	3-133
3.12.2.1—Temperature Range for Procedure A	3-133
3.12.2.2—Temperature Range for Procedure B	3-134
3.12.2.3—Design Thermal Movements	3-136
3.12.3—Temperature Gradient	3-136
3.12.4—Differential Shrinkage	3-137
3.12.5—Creep	3-137
3.12.6—Settlement	3-138
3.12.7—Secondary Forces from Post-Tensioning, <i>PS</i>	3-138
3.13—FRICTION FORCES: <i>FR</i>	3-138
3.14—VESSEL COLLISION: <i>CV</i>	3-138
3.14.1—General	3-138
3.14.2—Owner’s Responsibility	3-140
3.14.3—Operational Classification	3-140
3.14.4—Design Vessel	3-140
3.14.5—Annual Frequency of Collapse	3-141
3.14.5.1—Vessel Frequency Distribution	3-142

3.14.5.2—Probability of Aberrancy.....	3-143
3.14.5.2.1—General	3-143
3.14.5.2.2—Statistical Method	3-143
3.14.5.2.3—Approximate Method.....	3-143
3.14.5.3—Geometric Probability.....	3-146
3.14.5.4—Probability of Collapse	3-147
3.14.5.5 Protection Factor.....	3-147
3.14.6—Design Collision Velocity.....	3-150
3.14.7—Vessel Collision Energy.....	3-150
3.14.8—Ship Collision Force on Pier	3-151
3.14.9—Ship Bow Damage Length	3-153
3.14.10—Ship Collision Force on Superstructure.....	3-153
3.14.10.1—Collision with Bow	3-153
3.14.10.2—Collision with Deck House	3-153
3.14.10.3—Collision with Mast.....	3-154
3.14.11—Barge Collision Force on Pier.....	3-154
3.14.12—Barge Bow Damage Length.....	3-155
3.14.13—Damage at the Extreme Limit State	3-155
3.14.14—Application of Impact Force	3-156
3.14.14.1—Substructure Design.....	3-156
3.14.14.2—Superstructure Design.....	3-157
3.14.15—Protection of Substructures	3-157
3.14.16—Security Considerations	3-158
3.15—BLAST LOADING	3-159
3.15.1—Introduction.....	3-159
3.16—REFERENCES.....	3-159
APPENDIX A3—SEISMIC DESIGN FLOWCHARTS.....	3-167
APPENDIX B3—OVERSTRENGTH RESISTANCE	3-169

SECTION 3: LOADS AND LOAD FACTORS

3.1—SCOPE

This Section specifies minimum requirements for loads and forces, the limits of their application, load factors, and load combinations used for the design of new bridges. The load provisions may also be applied to the structural evaluation of existing bridges.

Where multiple performance levels are provided, the selection of the design performance level is the responsibility of the Owner.

A minimum load factor is specified for force effects that may develop during construction. Additional requirements for construction of segmental concrete bridges are specified in Article 5.14.2.

3.2—DEFINITIONS

Active Earth Pressure—Lateral pressure resulting from the retention of the earth by a structure or component that is tending to move away from the soil mass.

Active Earth Wedge—Wedge of earth with a tendency to become mobile if not retained by a structure or component.

Aeroelastic Vibration—Periodic, elastic response of a structure to wind.

Apparent Earth Pressure—Lateral pressure distribution for anchored walls constructed from the top down.

Axle Unit—Single axle or tandem axle.

Berm—An earthwork used to redirect or slow down impinging vehicles or vessels and to stabilize fill, embankment, or soft ground and cut slopes.

Centrifugal Force—A lateral force resulting from a change in the direction of a vehicle's movement.

Damper—A device that transfers and reduces forces between superstructure elements and/or superstructure and substructure elements, while permitting thermal movements. The device provides damping by dissipating energy under seismic, braking or other dynamic loads.

Deep Draft Waterways—A navigable waterway used by merchant ships with loaded drafts of 14–60+ ft.

Design Lane—A notional traffic lane positioned transversely on the roadway.

Design Thermal Movement Range—The structure movement range resulting from the difference between the maximum design temperature and minimum design temperature as defined in Article 3.12.

Design Water Depth—Depth of water at mean high water.

Distortion—Change in structural geometry.

Dolphin—Protective object that may have its own fender system and that is usually circular in plan and structurally independent from the bridge.

Dynamic Load Allowance—An increase in the applied static force effects to account for the dynamic interaction between the bridge and moving vehicles.

Equivalent Fluid—A notional substance whose density is such that it would exert the same pressure as the soil it is seen to replace for computational purposes.

C3.1

This Section includes, in addition to traditional loads, the force effects due to collisions, earthquakes, and settlement and distortion of the structure.

Vehicle and vessel collisions, earthquakes, and aeroelastic instability develop force effects that are dependent upon structural response. Therefore, such force effects cannot be determined without analysis and/or testing.

With the exception of segmental concrete bridges, construction loads are not provided, but the Designer should obtain pertinent information from prospective contractors.

Exposed—A condition in which a portion of a bridge's substructure or superstructure is subject to physical contact by any portion of a colliding vessel's bow, deck house, or mast.

Extreme—A maximum or a minimum.

Fender—Protection hardware attached to the structural component to be protected or used to delineate channels or to redirect aberrant vessels.

Frazil Ice—Ice resulting from turbulent water flow.

Global—Pertinent to the entire superstructure or to the whole bridge.

Influence Surface—A continuous or discretized function over a bridge deck whose value at a point, multiplied by a load acting normal to the deck at that point, yields the force effect being sought.

Knot—A velocity of 1.1508 mph.

Lane—The area of deck receiving one vehicle or one uniform load line.

Lever Rule—The statical summation of moments about one point to calculate the reaction at a second point.

Liquefaction—The loss of shear strength in a saturated soil due to excess hydrostatic pressure. In saturated, cohesionless soils, such a strength loss can result from loads that are applied instantaneously or cyclically, particularly in loose fine to medium sands that are uniformly graded.

Load—The effect of acceleration, including that due to gravity, imposed deformation, or volumetric change.

Local—Pertinent to a component or subassembly of components.

Mode of Vibration—A shape of dynamic deformation associated with a frequency of vibration.

Navigable Waterway—A waterway, determined by the U.S. Coast Guard as being suitable for interstate or foreign commerce, as described in 33CFR205-25.

Nominal Load—An arbitrarily selected design load level.

Normally Consolidated Soil—A soil for which the current effective overburden pressure is the same as the maximum pressure that has been experienced.

Overconsolidated Soil—A soil that has been under greater overburden pressure than currently exists.

Overall Stability—Stability of the entire retaining wall or abutment structure and is determined by evaluating potential slip surfaces located outside of the whole structure.

Overconsolidation Ratio—Ratio of the maximum preconsolidation pressure to the overburden pressure.

Passive Earth Pressure—Lateral pressure resulting from the earth's resistance to the lateral movement of a structure or component into the soil mass.

Permanent Loads—Loads and forces that are, or are assumed to be, either constant upon completion of construction or varying only over a long time interval.

Permit Vehicle—Any vehicle whose right to travel is administratively restricted in any way due to its weight or size.

Reliability Index—A quantitative assessment of safety expressed as the ratio of the difference between the mean resistance and mean force effect to the combined standard deviation of resistance and force effect.

Restrainers—A system of high-strength cables or rods that transfers forces between superstructure elements and/or superstructure and substructure elements under seismic or other dynamic loads after an initial slack is taken up, while permitting thermal movements.

Roadway Width—Clear space between barriers and/or curbs.

Setting Temperature—A structure's average temperature, which is used to determine the dimensions of a structure when a component is added or set in place.

Shallow Draft Waterways—A navigable waterway used primarily by barge vessels with loaded drafts of less than 9–10 ft.

Shock Transmission Unit (STU)—A device that provides a temporary rigid link between superstructure elements and/or superstructure and substructure elements under seismic, braking or other dynamic loads, while permitting thermal movements.

Structurally Continuous Barrier—A barrier, or any part thereof, that is interrupted only at deck joints.

Substructure—Structural parts of the bridge that support the horizontal span.

Superstructure—Structural parts of the bridge that provide the horizontal span.

Surcharge—A load used to model the weight of earth fill or other loads applied to the top of the retained material.

Tandem—Two closely spaced axles, usually connected to the same under-carriage, by which the equalization of load between the axles is enhanced.

Transient Loads—Loads and forces that can vary over a short time interval relative to the lifetime of the structure.

Tonne—2.205 kip.

Wall Friction Angle—An angle whose arctangent represents the apparent friction between a wall and a soil mass.

Wheel—Single or dual tire at one end of an axle.

Wheel Line—A transverse or longitudinal grouping of wheels.

3.3—NOTATION

3.3.1—General

A	=	plan area of ice floe (ft ²); depth of temperature gradient (in.) (C3.9.2.3) (3.12.3)
AEF	=	apparent earth pressure for anchored walls (ksf) (3.4.1)
AF	=	annual frequency of bridge element collapse (number/yr.) (C3.14.4)
a	=	length of uniform deceleration at braking (ft); truncated distance (ft); average bow damage length (ft) (C3.6.4) (C3.9.5) (C3.14.9)
a_B	=	bow damage length of standard hopper barge (ft) (3.14.11)
a_s	=	bow damage length of ship (ft) (3.14.9)
A_S	=	peak seismic ground acceleration coefficient modified by short-period site factor (3.10.4.2)
B	=	notional slope of backfill (degrees) (3.11.5.8.1)
B'	=	equivalent footing width (ft) (3.11.6.3)
B_e	=	width of excavation (ft) (3.11.5.7.2b)
B_M	=	beam (width) for barge, barge tows, and ship vessels (ft) (C3.14.5.1)
B_p	=	width of bridge pier (ft) (3.14.5.3)
BR	=	vehicular braking force; base rate of vessel aberrancy (3.3.2) (3.14.5.2.3)
b	=	braking force coefficient; width of a discrete vertical wall element (ft) (C3.6.4) (3.11.5.6)
b_f	=	width of applied load or footing (ft) (3.11.6.3)
C	=	coefficient to compute centrifugal forces; constant for terrain conditions in relation to wind approach (3.6.3) (C3.8.1.1)
C_a	=	coefficient for force due to crushing of ice (3.9.2.2)
C_D	=	drag coefficient (s ² lbs./ft ⁴) (3.7.3.1)
C_H	=	hydrodynamic mass coefficient (3.14.7)
C_L	=	lateral drag coefficient (C3.7.3.1)
C_n	=	coefficient for nose inclination to compute F_b (3.9.2.2)
C_{sm}	=	elastic seismic response coefficient for the m^{th} mode of vibration (3.10.4.2)

c	= soil cohesion (ksf) (3.11.5.4)
c_f	= distance from back of a wall face to the front of an applied load or footing (ft) (3.11.6.3)
D	= depth of embedment for a permanent nongravity cantilever wall with discrete vertical wall elements (ft) (3.11.5.6)
D_B	= bow depth (ft) (C3.14.5.1)
D_E	= minimum depth of earth cover (ft) (3.6.2.2)
D_o	= calculated embedment depth to provide equilibrium for nongravity cantilevered with continuous vertical elements by the simplified method (ft) (3.11.5.6)
DWT	= size of vessel based on deadweight tonnage (tonne) (C3.14.1)
D_1	= effective width of applied load at any depth (ft) (3.11.6.3)
d	= depth of potential base failure surface below base of excavation (ft); horizontal distance from the back of a wall face to the centerline of an applied load (ft) (3.11.5.7.2b) (3.11.6.3)
d_c	= total thickness of cohesive soil layers in the top 100 ft (3.10.3.1)
d_s	= total thickness of cohesionless soil layers in the top 100 ft (3.10.3.1)
E	= Young's modulus (ksf) (C3.9.5)
E_B	= deformation energy (kip-ft) (C3.14.11)
e'	= eccentricity of load on footing (ft) (3.11.6.3)
F	= longitudinal force on pier due to ice floe (kip); force required to fail an ice sheet (kip/ft); force at base of nongravity cantilevered wall required to provide force equilibrium (kip/ft) (3.9.2.2) (C3.9.5) (3.11.5.6)
F_a	= site factor for short-period range of acceleration response spectrum (3.10.3.2)
F_b	= horizontal force due to failure of ice flow due to bending (kip) (3.9.2.2)
F_c	= horizontal force due to crushing of ice (kip) (3.9.2.2)
F_{pga}	= site factor at zero-period on acceleration response spectrum (3.10.3.2)
FS_{BH}	= factor of safety against basal heave (C3.11.5.6)
F_t	= transverse force on pier due to ice flow (kip) (3.9.2.4.1)
F_v	= vertical ice force due to adhesion (kip); site factor for long-period range of acceleration response spectrum (3.9.5) (3.10.3.2)
F_1	= lateral force due to earth pressure (kip/ft) (3.11.6.3)
F_2	= lateral force due to traffic surcharge (kip/ft) (3.11.6.3)
f	= constant applied in calculating the coefficient C used to compute centrifugal forces, taken equal to 4/3 for load combinations other than fatigue and 1.0 for fatigue (3.6.3)
f'_c	= specified compressive strength of concrete for use in design (ksi) (3.5.1)
g	= gravitational acceleration (ft/s^2) (3.6.3)
H	= ultimate bridge element strength (kip); final height of retaining wall (ft); total excavation depth (ft); resistance of bridge component to a horizontal force (kip) (C3.11.1) (3.11.5.7.1) (3.14.5.4)
H_L	= depth of barge head-block on its bow (ft) (3.14.14.1)
H_p	= ultimate bridge pier resistance (kip) (3.14.5.4)
H_s	= ultimate bridge superstructure resistance (kip) (3.14.5.4)
H_1	= distance from ground surface to uppermost ground anchor (ft) (3.11.5.7.1)
H_{n+1}	= distance from base of excavation to lowermost ground anchor (ft) (3.11.5.7.1)
h	= notional height of earth pressure diagram (ft) (3.11.5.7)
h_{eq}	= equivalent height of soil for vehicular load (ft) (3.11.6.4)
IM	= dynamic load allowance (C3.6.1.2.5)
KE	= design impact energy of vessel collision (kip-ft) (3.14.7)
K_1	= ice force reduction factor for small streams (C3.9.2.3)
k	= coefficient of lateral earth pressure; number of cohesive soil layers in the top 100 ft (3.11.6.2) (3.10.3.1)
k_a	= coefficient of active lateral earth pressure (3.11.5.1)
k_o	= coefficient of at rest lateral earth pressure (3.11.5.1)
k_p	= coefficient of passive lateral earth pressure (3.11.5.1)
k_s	= coefficient of earth pressure due to surcharge (3.11.6.1)
L	= perimeter of pier (ft); length of soil reinforcing elements in an MSE wall (ft); length of footing (ft); expansion length (in.) (3.9.5) (3.11.5.8) (3.11.6.3) (3.12.2.3)
ℓ	= characteristic length (ft); center-to-center spacing of vertical wall elements (ft) (C3.9.5) (3.11.5.6)
LOA	= length overall of ship or barge tow including the tug or tow boat (ft) (3.14.5)
m	= multiple presence factor; number of cohesionless soil layers in the top 100 ft (3.6.1.1.2) (3.10.3.1)
N	= number of one-way passages of vessels navigating through the bridge (number/yr.) (3.14.5)
\bar{N}	= average Standard Penetration Test (SPT) blow count (blows/ft) (ASTM D1586) for the upper 100 ft of the soil profile (3.10.3.1)

\bar{N}_{ch}	=	average Standard Penetration Test (SPT) blow count (blows/ft) (ASTM D1586) for cohesive soil layers in the upper 100 ft of the soil profile and \bar{s}_u for cohesive soil layers ($PI > 20$) in the top 100 ft (\bar{s}_u method) (3.10.3.1)
N_{chi}	=	blowcount for a cohesionless soil layer (not to exceed 100 blows/ft in the above expression) (3.10.3.1)
N_i	=	Standard Penetration Test blow count of a layer (not to exceed 100 blows/ft in the above expression). Note that when using Method B, \bar{N} values are for cohesionless soils and cohesive soil and rock layers within the upper 100 ft Where refusal is met for a rock layer, N_i should be taken as 100 blows/ft (3.10.3.1)
N_s	=	stability number (3.11.5.6)
OCR	=	overconsolidation ratio (3.11.5.2)
P	=	maximum vertical force for single ice wedge (kip); load resulting from vessel impact (kip); concentrated wheel load (kip); live load intensity; point load (kip) (C3.9.5) (3.14.5.4) (C3.6.1.2.5) (C3.11.6.2) (3.11.6.1)
PA	=	probability of vessel aberrancy (3.14.5)
P_a	=	force resultant per unit width of wall (kip/ft) (3.11.5.8.1)
P_B	=	barge collision impact force for head-on collision between barge bow and a rigid object (kip); base wind pressure corresponding to a wind speed of 100 mph (ksf) (3.14.11) (3.8.1.2)
\bar{P}_B	=	average equivalent static barge impact force resulting from Meir-Dornberg Study (kip) (C3.14.11)
P_{BH}	=	ship collision impact force between ship bow and a rigid superstructure (kip) (3.14.10.1)
PC	=	probability of bridge collapse (3.14.5)
P_D	=	design wind pressure (ksf) (3.8.1.2.1)
P_{DH}	=	ship collision impact force between ship deck house and a rigid superstructure (kip) (3.14.5.4)
PG	=	geometric probability of vessel collision with bridge pier/span (3.14.5)
PGA	=	peak seismic ground acceleration coefficient on rock (Site Class B) (3.10.2.1) (3.10.4.2)
P_H	=	lateral force due to superstructure or other concentrated lateral loads (kip/ft) (3.11.6.3)
P_h	=	horizontal component of resultant earth pressure on wall (kip/ft) (3.11.5.5)
PI	=	plasticity index (ASTM D4318) (3.10.3.1)
P_{MT}	=	ship collision impact force between ship mast and a rigid superstructure (kip) (3.14.5.4)
P_p	=	passive earth pressure (kip/ft) (3.11.5.4)
P_S	=	ship collision impact force for head-on collision between ship bow and a rigid object (kip) (3.14.5.4)
P_v	=	vertical component of resultant earth pressure on wall (kip/ft); load per linear foot of strip footing (kip/ft) (3.11.5.5) (3.11.6.3)
P'_v	=	load on isolated rectangular footing or point load (kip) (3.11.6.3)
p	=	effective ice crushing strength (ksf); stream pressure (ksf); basic earth pressure (psf); fraction of truck traffic in a single lane; load intensity (ksf) (3.9.2.2) (3.7.3.1) (3.11.5.1) (3.6.1.4.2) (3.11.6.1)
p_a	=	apparent earth pressure (ksf); maximum ordinate of pressure diagram (ksf) (3.11.5.3) (3.11.5.7.1)
p_p	=	passive earth pressure (ksf) (3.11.5.4)
Q	=	total factored load; load intensity for infinitely long line loading (kip/ft) (3.4.1) (3.11.6.2)
Q_i	=	force effects (3.4.1)
q	=	surcharge pressure (ksf) (3.11.6.3)
q_s	=	uniform surcharge pressure (ksf) (3.11.6.1)
R	=	radius of curvature (ft); radius of circular pier (ft); seismic response modification factor; reduction factor of lateral passive earth pressure; radial distance from point of load application to a point on the wall (ft); reaction force to be resisted by subgrade below base of excavation (kip/ft) (3.6.3) (3.9.5) (3.10.7.1) (3.11.5.4) (3.11.6.1) (3.11.5.7.1)
R_B	=	PA correction factor for bridge location (3.14.5.2.3)
R_{BH}	=	ratio of exposed superstructure depth to the total ship bow depth (3.14.10.1)
R_C	=	PA correction factor for currents parallel to vessel transit path (3.14.5.2.3)
R_D	=	PA correction factor for vessel traffic density (3.14.5.2.3)
R_{DH}	=	reduction factor for ship deck house collision force (3.14.10.2)
R_{XC}	=	PA correction factor for cross-currents acting perpendicular to vessel transit path (3.14.5.2.3)
r	=	radius of pier nose (ft) (C3.9.2.3)
S_{DS}	=	horizontal response spectral acceleration coefficient at 0.2-s period modified by short-period site factor (3.10.4.2)
S_{D1}	=	horizontal response spectral acceleration coefficient at 1.0-s period modified by long-period site factor (3.10.4.2)
S_f	=	freezing index (C3.9.2.2)
S_m	=	shear strength of rock mass (ksf) (3.11.5.6)
S_S	=	horizontal response spectral acceleration coefficient at 0.2-s period on rock (Site Class B) (3.10.2.1) (3.10.4.2)

S_u	=	undrained shear strength of cohesive soil (ksf) (3.11.5.6)
S_{ub}	=	undrained strength of soil below excavation base (ksf) (3.11.5.7.2b)
S_v	=	vertical spacing of reinforcements (ft) (3.11.5.8.1)
\bar{s}_u	=	average undrained shear strength in ksf (ASTM D2166 or ASTM D2850) for the upper 100 ft of the soil profile (3.10.3.1)
s_{ui}	=	undrained shear strength for a cohesive soil layer (not to exceed 5.0 ksf in the above expression) (3.10.3.1)
S_1	=	horizontal response spectral acceleration coefficient at 1.0-s period on rock (Site Class B) (3.10.2.1) (3.10.4.2)
T	=	mean daily air temperature (°F) (C3.9.2.2)
T_F	=	period of fundamental mode of vibration of bridge (s) (3.10.2.2)
T_{hi}	=	horizontal load in anchor i (kip/ft) (3.11.5.7.1)
T_m	=	period of vibration for m th mode (s) (3.10.4.2)
T_{max}	=	applied load to reinforcement in a mechanically stabilized earth wall (kip/ft) (3.11.5.8.2)
$T_{MaxDesign}$	=	maximum design temperature used for thermal movement effects (°F) (3.12.2.1) (3.12.2.2) (3.12.2.3)
$T_{MinDesign}$	=	minimum design temperature used for thermal movement effects (°F) (3.12.2.1) (3.12.2.2) (3.12.2.3)
T_S	=	corner period at which acceleration response spectrum changes from being independent of period to being inversely proportional to period (s) (3.10.4.2)
T_0	=	reference period used to define shape of acceleration response spectrum (s) (3.10.4.2)
t	=	thickness of ice (ft); thickness of deck (in.) (3.9.2.2) (3.12.3)
V	=	design velocity of water (ft/s); design impact speed of vessel (ft/s) (3.7.3.1) (3.14.6)
V_B	=	base wind velocity taken as 100 mph (3.8.1.1)
V_C	=	waterway current component acting parallel to the vessel transit path (knots) (3.14.5.2.3)
V_{DZ}	=	design wind velocity at design Elevation Z (mph) (3.8.1.1)
V_{MIN}	=	minimum design impact velocity taken not less than the yearly mean current velocity for the bridge location (ft/s) (3.14.6)
V_T	=	vessel transit speed in the navigable channel (ft/s) (3.14.6)
V_{XC}	=	waterway current component acting perpendicular to the vessel transit path (knots) (3.14.5.2.3)
V_0	=	friction velocity, a meteorological wind characteristic for various upwind surface characteristics (mph) (3.8.1.1)
V_{30}	=	wind speed at 30.0 ft above low ground or water level (mph) (3.8.1.1)
v	=	highway design speed (ft/s) (3.6.3)
\bar{v}_s	=	average shear wave velocity for the upper 100 ft of the soil profile (3.10.3.1)
W	=	displacement weight of vessel (tonne) (C3.14.5.1)
w	=	width of clear roadway (ft); width of clear pedestrian and/or bicycle bridge (ft); width of pier at level of ice action (ft); specific weight of water (kcf); moisture content (ASTM D2216) (3.6.1.1.1) (3.6.1.6) (3.9.2.2) (C3.7.3.1) (3.10.3.1)
X	=	horizontal distance from back of wall to point of load application (ft); distance to bridge element from the centerline of vessel transit path (ft) (3.11.6.2) (3.14.6)
X_c	=	distance to edge of channel from centerline of vessel transit path (ft) (3.14.6)
X_L	=	distance from centerline of vessel transit path equal to $3 \times LOA$ (ft) (3.14.6)
X_1	=	distance from the back of the wall to the start of the line load (ft) (3.11.6.2)
X_2	=	length of the line load (ft) (3.11.6.2)
Z	=	structure height above low ground or water level > 30.0 ft (ft); depth below surface of soil (ft); depth from the ground surface to a point on the wall under consideration (ft); vertical distance from point of load application to the elevation of a point on the wall under consideration (ft) (3.8.1.1) (3.11.6.3) (3.11.6.2)
Z_0	=	friction length of upstream fetch, a meteorological wind characteristic (ft) (3.8.1.1)
Z_2	=	depth where effective width intersects back of wall face (ft) (3.11.6.3)
z	=	depth below surface of backfill (ft) (3.11.5.1)
α	=	constant for terrain conditions in relation to wind approach; coefficient for local ice condition; inclination of pier nose with respect to a vertical axis (degrees); inclination of back of wall with respect to a vertical axis (degrees); angle between foundation wall and a line connecting the point on the wall under consideration and a point on the bottom corner of the footing nearest to the wall (rad); coefficient of thermal expansion (in./in./°F) (C3.8.1.1) (C3.9.2.2) (3.9.2.2) (C3.11.5.3) (3.11.6.2) (3.12.2.3)
β	=	safety index; nose angle in a horizontal plane used to calculate transverse ice forces (degrees); slope of backfill surface behind retaining wall; {+ for slope up from wall; - for slope down from wall} (degrees) (C3.4.1) (3.9.2.4.1) (3.11.5.3)

β'	=	slope of ground surface in front of wall {+ for slope up from wall; – for slope down from wall} (degrees) (3.11.5.6)
γ	=	load factors; unit weight of materials (kcf); unit weight of water (kcf); unit weight of soil (kcf) (C3.4.1) (3.5.1) (C3.9.5) (3.11.5.1)
γ_s	=	unit weight of soil (kcf) (3.11.5.1)
γ'_s	=	effective soil unit weight (kcf) (3.11.5.6)
γ_{EQ}	=	load factor for live load applied simultaneously with seismic loads (3.4.1)
γ_{eq}	=	equivalent-fluid unit weight of soil (kcf) (3.11.5.5)
γ_i	=	load factor (3.4.1)
γ_p	=	load factor for permanent loading (3.4.1)
γ_{SE}	=	load factor for settlement (3.4.1)
γ_{TG}	=	load factor for temperature gradient (3.4.1)
Δ	=	movement of top of wall required to reach minimum active or maximum passive pressure by tilting or lateral translation (ft) (C3.11.1) (3.11.5.5)
Δ_p	=	constant horizontal earth pressure due to uniform surcharge (ksf) (3.11.6.1)
Δ_{ph}	=	constant horizontal pressure distribution on wall resulting from various types of surcharge loading (ksf) (3.11.6.2)
Δ_T	=	design thermal movement range (in.) (3.12.2.3)
$\Delta\sigma_H$	=	horizontal stress due to surcharge load (ksf) (3.11.6.3)
$\Delta\sigma_v$	=	vertical stress due to surcharge load (ksf) (3.11.6.3)
δ	=	angle of truncated ice wedge (degrees); friction angle between fill and wall (degrees); angle between foundation wall and a line connecting the point on the wall under consideration and a point on the bottom corner of the footing furthest from the wall (rad) (C3.9.5) (3.11.5.3) (3.11.6.2)
η_i	=	load modifier specified in Article 1.3.2; wall face batter (3.4.1) (3.11.5.9)
θ	=	angle of back of wall to the horizontal (degrees); angle of channel turn or bend (degrees); angle between direction of stream flow and the longitudinal axis of pier (degrees) (3.11.5.3) (3.14.5.2.3) (3.7.3.2)
θ_f	=	friction angle between ice floe and pier (degrees) (3.9.2.4.1)
σ	=	standard deviation of normal distribution (3.14.5.3)
σ_T	=	tensile strength of ice (ksf) (C3.9.5)
ν	=	Poisson's Ratio (dim.) (3.11.6.2)
ϕ	=	resistance factors (C3.4.1)
ϕ_f	=	angle of internal friction (degrees) (3.11.5.4)
ϕ'_f	=	effective angle of internal friction (degrees) (3.11.5.2)
ϕ_r	=	internal friction angle of reinforced fill (degrees) (3.11.6.3)
ϕ'_s	=	angle of internal friction of retained soil (degrees) (3.11.5.6)

3.3.2—Load and Load Designation

The following permanent and transient loads and forces shall be considered:

- Permanent Loads

CR	=	force effects due to creep
DD	=	downdrag force
DC	=	dead load of structural components and nonstructural attachments
DW	=	dead load of wearing surfaces and utilities
EH	=	horizontal earth pressure load
EL	=	miscellaneous locked-in force effects resulting from the construction process, including jacking apart of cantilevers in segmental construction
ES	=	earth surcharge load
EV	=	vertical pressure from dead load of earth fill

PS = secondary forces from post-tensioning
SH = force effects due to shrinkage

- Transient Loads

BL = blast loading
BR = vehicular braking force
CE = vehicular centrifugal force
CT = vehicular collision force
CV = vessel collision force
EQ = earthquake load
FR = friction load
IC = ice load
IM = vehicular dynamic load allowance
LL = vehicular live load
LS = live load surcharge
PL = pedestrian live load
SE = force effect due to settlement
TG = force effect due to temperature gradient
TU = force effect due to uniform temperature
WA = water load and stream pressure
WL = wind on live load
WS = wind load on structure

3.4—LOAD FACTORS AND COMBINATIONS

3.4.1—Load Factors and Load Combinations

The total factored force effect shall be taken as:

$$Q = \sum \eta_i \gamma_i Q_i \quad (3.4.1-1)$$

where:

η_i = load modifier specified in Article 1.3.2
 Q_i = force effects from loads specified herein
 γ_i = load factors specified in Tables 3.4.1-1 and 3.4.1-2

Components and connections of a bridge shall satisfy Eq. 1.3.2.1-1 for the applicable combinations of factored extreme force effects as specified at each of the following limit states:

- Strength I—Basic load combination relating to the normal vehicular use of the bridge without wind.
- Strength II—Load combination relating to the use of the bridge by Owner-specified special design vehicles, evaluation permit vehicles, or both without wind.
- Strength III—Load combination relating to the bridge exposed to wind velocity exceeding 55 mph.

C3.4.1

The background for the load factors specified herein, and the resistance factors specified in other Sections of these Specifications is developed in Nowak (1992).

The permit vehicle should not be assumed to be the only vehicle on the bridge unless so assured by traffic control. See Article 4.6.2.2.5 regarding other traffic on the bridge simultaneously.

Vehicles become unstable at higher wind velocities. Therefore, high winds prevent the presence of significant live load on the bridge.

- Strength IV—Load combination relating to very high dead load to live load force effect ratios.

The standard calibration process for the strength limit state consists of trying out various combinations of load and resistance factors on a number of bridges and their components. Combinations that yield a safety index close to the target value of $\beta = 3.5$ are retained for potential application. From these are selected constant load factors γ and corresponding resistance factors ϕ for each type of structural component reflecting its use.

This calibration process had been carried out for a large number of bridges with spans not exceeding 200 ft. These calculations were for completed bridges. For the primary components of large bridges, the ratio of dead and live load force effects is rather high, and could result in a set of resistance factors different from those found acceptable for small- and medium-span bridges. It is believed to be more practical to investigate one additional load case than to require the use of two sets of resistance factors with the load factors provided in Strength Load Combination I, depending on other permanent loads present. Spot checks had been made on a few bridges with up to 600-ft spans, and it appears that Strength Load Combination IV will govern where the dead load to live load force effect ratio exceeds about 7.0. This load combination can control during investigation of construction stages.

- Strength V—Load combination relating to normal vehicular use of the bridge with wind of 55 mph velocity.
- Extreme Event I—Load combination including earthquake. The load factor for live load γ_{EQ} , shall be determined on a project-specific basis.
- Extreme Event II—Load combination relating to ice load, collision by vessels and vehicles, check floods, and certain hydraulic events with a reduced live load other than that which is part of the vehicular collision load, *CT*. The cases of check floods shall not be combined with *BL*, *CV*, *CT*, or *IC*.

Past editions of the Standard Specifications used $\gamma_{EQ} = 0.0$. This issue is not resolved. The possibility of partial live load, i.e., $\gamma_{EQ} < 1.0$, with earthquakes should be considered. Application of Turkstra's rule for combining uncorrelated loads indicates that $\gamma_{EQ} = 0.50$ is reasonable for a wide range of values of average daily truck traffic (ADTT).

The following applies to both Extreme Event I and II:

- The recurrence interval of extreme events is thought to exceed the design life.
- Although these limit states include water loads, *WA*, the effects due to *WA* are considerably less significant than the effects on the structure stability due to scour. Therefore, unless specific site conditions dictate otherwise, local pier scour and contraction scour depths should not be combined with *BL*, *EQ*, *CT*, *CV*, or *IC*. However, the effects due to degradation of the channel should be considered. Alternatively, one-half of the total scour may be considered in combination with *BL*, *EQ*, *CT*, *CV*, or *IC*.
- The joint probability of these events is extremely low, and, therefore, the events are specified to be applied separately. Under these extreme conditions, the structure may undergo considerable inelastic deformation by which locked-in force effects due to *TU*, *TG*, *CR*, *SH*, and *SE* are expected to be relieved.

- Service I—Load combination relating to the normal operational use of the bridge with a 55 mph wind and all loads taken at their nominal values. Also related to deflection control in buried metal structures, tunnel liner plate, and thermoplastic pipe, to control crack width in reinforced concrete structures, and for transverse analysis relating to tension in concrete segmental girders. This load combination should also be used for the investigation of slope stability.
- Service II—Load combination intended to control yielding of steel structures and slip of slip-critical connections due to vehicular live load.
- Service III—Load combination for longitudinal analysis relating to tension in prestressed concrete superstructures with the objective of crack control and to principal tension in the webs of segmental concrete girders.
- Service IV—Load combination relating only to tension in prestressed concrete columns with the objective of crack control.
- Fatigue I—Fatigue and fracture load combination related to infinite load-induced fatigue life.

The 0.50 live load factor signifies a low probability of the concurrence of the maximum vehicular live load (other than *CT*) and the extreme events.

Compression in prestressed concrete components and tension in prestressed bent caps are investigated using this load combination. Service III is used to investigate tensile stresses in prestressed concrete components.

This load combination corresponds to the overload provision for steel structures in past editions of the AASHTO Specifications, and it is applicable only to steel structures. From the point of view of load level, this combination is approximately halfway between that used for Service I and Strength I Limit States.

The live load specified in these specifications reflects, among other things, current exclusion weight limits mandated by various jurisdictions. Vehicles permitted under these limits have been in service for many years prior to 1993. For longitudinal loading, there is no nationwide physical evidence that these vehicles have caused cracking in existing prestressed concrete components. The statistical significance of the 0.80 factor on live load is that the event is expected to occur about once a year for bridges with two traffic lanes, less often for bridges with more than two traffic lanes, and about once a day for bridges with a single traffic lane. Service I should be used for checking tension related to transverse analysis of concrete segmental girders.

The principal tensile stress check is introduced in order to verify the adequacy of webs of segmental concrete girder bridges for longitudinal shear and torsion.

The 0.70 factor on wind represents an 84 mph wind. This should result in zero tension in prestressed concrete columns for ten-year mean reoccurrence winds. The prestressed concrete columns must still meet strength requirements as set forth in Load Combination Strength III in Article 3.4.1.

It is not recommended that thermal gradient be combined with high wind forces. Superstructure expansion forces are included.

The load factor for the Fatigue I load combination, applied to a single design truck having the axle spacing specified in Article 3.6.1.4.1, reflects load levels found to be representative of the maximum stress range of the truck population for infinite fatigue life design. The factor was chosen on the assumption that the maximum stress range in the random variable spectrum is twice the effective stress range caused by Fatigue II load combination.

- Fatigue II—Fatigue and fracture load combination related to finite load-induced fatigue life.

The load factors for various loads comprising a design load combination shall be taken as specified in Table 3.4.1-1. All relevant subsets of the load combinations shall be investigated. For each load combination, every load that is indicated to be taken into account and that is germane to the component being designed, including all significant effects due to distortion, shall be multiplied by the appropriate load factor and multiple presence factor specified in Article 3.6.1.1.2, if applicable. The products shall be summed as specified in Eq. 1.3.2.1-1 and multiplied by the load modifiers specified in Article 1.3.2.

The factors shall be selected to produce the total extreme factored force effect. For each load combination, both positive and negative extremes shall be investigated.

In load combinations where one force effect decreases another effect, the minimum value shall be applied to the load reducing the force effect. For permanent force effects, the load factor that produces the more critical combination shall be selected from Table 3.4.1-2. Where the permanent load increases the stability or load-carrying capacity of a component or bridge, the minimum value of the load factor for that permanent load shall also be investigated.

The load factor for the Fatigue II load combination, applied to a single design truck, reflects a load level found to be representative of the effective stress range of the truck population with respect to a small number of stress range cycles and to their cumulative effects in steel elements, components, and connections for finite fatigue life design.

This Article reinforces the traditional method of selecting load combinations to obtain realistic extreme effects and is intended to clarify the issue of the variability of permanent loads and their effects. As has always been the case, the Owner or Designer may determine that not all of the loads in a given load combination apply to the situation under investigation.

It is recognized herein that the actual magnitude of permanent loads may also be less than the nominal value. This becomes important where the permanent load reduces the effects of transient loads.

It has been observed that permanent loads are more likely to be greater than the nominal value than to be less than this value.

The earth load factor for thermoplastic culverts is set to 1.3; however, to preserve the overall safety at the same levels as historical specifications, an earth-load-installation factor is introduced later in these Specifications as part of the implementation of NCHRP Report 631. This factor may be adjusted based on field control of construction practices.

In the application of permanent loads, force effects for each of the specified six load types should be computed separately. It is unnecessary to assume that one type of load varies by span, length, or component within a bridge. For example, when investigating uplift at a bearing in a continuous beam, it would not be appropriate to use the maximum load factor for permanent loads in spans that produce a negative reaction and the minimum load factor in spans that produce a positive reaction. Consider the investigation of uplift. Uplift, which was treated as a separate load case in past editions of the AASHTO Standard Specifications, now becomes a strength load combination. Where a permanent load produces uplift, that load would be multiplied by the maximum load factor, regardless of the span in which it is located. If another permanent load reduces the uplift, it would be multiplied by the minimum load factor, regardless of the span in which it is located. For example, at Strength I Limit State where the permanent load reaction is positive and live load can cause a negative reaction, the load combination would be $0.9DC + 0.65DW + 1.75(LL + IM)$. If both reactions were negative, the load combination would be $1.25DC + 1.50DW + 1.75(LL + IM)$. For each force effect, both extreme combinations may need to be investigated by applying either the high or the low load factor as appropriate. The algebraic sums of these products are the total force effects for which the bridge and its components should be designed.

The larger of the two values provided for load factor of TU shall be used for deformations and the smaller values for all other effects. For simplified analysis of concrete substructures in the strength limit state, a value of 0.50 for γ_{TU} may be used when calculating force effects, but shall be taken in conjunction with the gross moment of inertia in the columns or piers. When a refined analysis is completed for concrete substructures in the strength limit state, a value of 1.0 for γ_{TU} shall be used in conjunction with a partially cracked moment of inertia determined by analysis. For concrete substructures in the strength limit state, the value of 0.50 for γ_{PS} , γ_{CR} , and γ_{SH} may similarly be used when calculating force effects in non-segmental structures, but shall be taken in conjunction with the gross moment of inertia in the columns or piers. For steel substructures, a value of 1.0 for γ_{TU} , γ_{PS} , γ_{CR} , and γ_{SH} shall be used.

The evaluation of overall stability of retained fills, as well as earth slopes with or without a shallow or deep foundation unit should be investigated at the service limit state based on the Service I Load Combination and an appropriate resistance factor as specified in Article 11.5.6 and Article 11.6.2.3.

For structural plate box structures complying with the provisions of Article 12.9, the live load factor for the vehicular live loads LL and IM shall be taken as 2.0.

The load factor for temperature gradient, γ_{TG} , should be considered on a project-specific basis. In lieu of project-specific information to the contrary, γ_{TG} may be taken as:

- 0.0 at the strength and extreme event limit states,
- 1.0 at the service limit state when live load is not considered, and
- 0.50 at the service limit state when live load is considered.

PS , CR , SH , TU , and TG are superimposed deformations as defined in Article 3.12. Load factors for TU , and TG are as shown in Table 3.4.1-1. Load factors for PS , CR , and SH are as shown in Table 3.4.1-3. For prestressed members in typical bridge types, secondary prestressing, creep and shrinkage are generally designed for in the service limit state. In concrete segmental structures, CR and SH are factored by γ_p for DC because analysis for time-dependent effects in segmental bridges is nonlinear. Abutments, piers, columns, and bent caps are to be considered as substructure components.

The calculation of displacements for TU utilizes a factor greater than 1.0 to avoid undersizing joints, expansion devices, and bearings.

Applying these criteria for the evaluation of the sliding resistance of walls:

- The vertical earth load on the rear of a cantilevered retaining wall would be multiplied by γ_{pmin} (1.00) and the weight of the structure would be multiplied by γ_{pmin} (0.90) because these forces result in an increase in the contact stress (and shear strength) at the base of the wall and foundation.
- The horizontal earth load on a cantilevered retaining wall would be multiplied by γ_{pmax} (1.50) for an active earth pressure distribution because the force results in a more critical sliding force at the base of the wall.

Similarly, the values of γ_{pmax} for structure weight (1.25), vertical earth load (1.35) and horizontal active earth pressure (1.50) would represent the critical load combination for an evaluation of foundation bearing resistance.

Water load and friction are included in all strength load combinations at their respective nominal values. For creep and shrinkage, the specified nominal values should be used. For friction, settlement, and water loads, both minimum and maximum values need to be investigated to produce extreme load combinations.

The load factor for temperature gradient should be determined on the basis of the:

- Type of structure, and
- Limit state being investigated.

Open girder construction and multiple steel box girders have traditionally, but perhaps not necessarily correctly, been designed without consideration of temperature gradient, i.e., $\gamma_{TG} = 0.0$.

The load factor for settlement, γ_{SE} , should be considered on a project-specific basis. In lieu of project-specific information to the contrary, γ_{SE} , may be taken as 1.0. Load combinations which include settlement shall also be applied without settlement.

For segmentally constructed bridges, the following combination shall be investigated at the service limit state:

$$DC + DW + EH + EV + ES + WA + CR + SH + TG + EL + PS$$

(3.4.1-2)

Table 3.4.1-1—Load Combinations and Load Factors

Load Combination Limit State	DC DD DW EH EV ES EL PS CR SH	LL IM CE BR PL LS	WA	WS	WL	FR	TU	TG	SE	Use One of These at a Time				
										EQ	BL	IC	CT	CV
Strength I (unless noted)	γ_p	1.75	1.00	—	—	1.00	0.50/1.20	γ_{TG}	γ_{SE}	—	—	—	—	—
Strength II	γ_p	1.35	1.00	—	—	1.00	0.50/1.20	γ_{TG}	γ_{SE}	—	—	—	—	—
Strength III	γ_p	—	1.00	1.40	—	1.00	0.50/1.20	γ_{TG}	γ_{SE}	—	—	—	—	—
Strength IV	γ_p	—	1.00	—	—	1.00	0.50/1.20	—	—	—	—	—	—	—
Strength V	γ_p	1.35	1.00	0.40	1.0	1.00	0.50/1.20	γ_{TG}	γ_{SE}	—	—	—	—	—
Extreme Event I	γ_p	γ_{EQ}	1.00	—	—	1.00	—	—	—	1.00	—	—	—	—
Extreme Event II	γ_p	0.50	1.00	—	—	1.00	—	—	—	—	1.00	1.00	1.00	1.00
Service I	1.00	1.00	1.00	0.30	1.0	1.00	1.00/1.20	γ_{TG}	γ_{SE}	—	—	—	—	—
Service II	1.00	1.30	1.00	—	—	1.00	1.00/1.20	—	—	—	—	—	—	—
Service III	1.00	0.80	1.00	—	—	1.00	1.00/1.20	γ_{TG}	γ_{SE}	—	—	—	—	—
Service IV	1.00	—	1.00	0.70	—	1.00	1.00/1.20	—	1.0	—	—	—	—	—
Fatigue I— LL, IM & CE only	—	1.50	—	—	—	—	—	—	—	—	—	—	—	—
Fatigue II— LL, IM & CE only	—	0.75	—	—	—	—	—	—	—	—	—	—	—	—

Table 3.4.1-2—Load Factors for Permanent Loads, γ_p

Type of Load, Foundation Type, and Method Used to Calculate Downdrag		Load Factor	
		Maximum	Minimum
<i>DC</i> : Component and Attachments		1.25	0.90
<i>DC</i> : Strength IV only		1.50	0.90
<i>DD</i> : Downdrag	Piles, α Tomlinson Method	1.4	0.25
	Piles, λ Method	1.05	0.30
	Drilled shafts, O’Neill and Reese (1999) Method	1.25	0.35
<i>DW</i> : Wearing Surfaces and Utilities		1.50	0.65
<i>EH</i> : Horizontal Earth Pressure			
• Active		1.50	0.90
• At-Rest		1.35	0.90
• <i>AEP</i> for anchored walls		1.35	N/A
<i>EL</i> : Locked-in Construction Stresses		1.00	1.00
<i>EV</i> : Vertical Earth Pressure			
• Overall Stability		1.00	N/A
• Retaining Walls and Abutments		1.35	1.00
• Rigid Buried Structure		1.30	0.90
• Rigid Frames		1.35	0.90
• Flexible Buried Structures			
o Metal Box Culverts and Structural Plate Culverts with Deep Corrugations		1.5	0.9
o Thermoplastic culverts		1.3	0.9
o All others		1.95	0.9
<i>ES</i> : Earth Surcharge		1.50	0.75

Table 3.4.1-3—Load Factors for Permanent Loads Due to Superimposed Deformations, γ_p

Bridge Component	<i>PS</i>	<i>CR, SH</i>
Superstructures—Segmental Concrete Substructures supporting Segmental Superstructures (see 3.12.4, 3.12.5)	1.0	See γ_p for <i>DC</i> , Table 3.4.1-2
Concrete Superstructures—non-segmental	1.0	1.0
Substructures supporting non-segmental Superstructures		
• using I_g	0.5	0.5
• using $I_{effective}$	1.0	1.0
Steel Substructures	1.0	1.0

Where prestressed components are used in conjunction with steel girders, the force effects from the following sources shall be considered as construction loads, *EL*:

- In conjunction with longitudinal prestressing of a precast deck prior to making the deck sections composite with the girders, the friction between the precast deck sections and the steel girders.
- When longitudinal post-tensioning is performed after the deck becomes composite with the girders, the additional forces induced in the steel girders and shear connectors.
- The effects of differential creep and shrinkage of the concrete.
- The Poisson effect.

The load factor for live load in Extreme Event Load Combination I, γ_{EQ} , shall be determined on a project-specific basis.

Engineering judgment shall be exercised when applying blast loadings and when combining them with other loads.

3.4.2—Load Factors for Construction Loads

3.4.2.1—Evaluation at the Strength Limit State

All appropriate strength load combinations in Table 3.4.1-1, modified as specified herein, shall be investigated.

When investigating Strength Load Combinations I, III, and V during construction, load factors for the weight of the structure and appurtenances, *DC* and *DW*, shall not be taken to be less than 1.25.

Unless otherwise specified by the Owner, the load factor for construction loads and for any associated dynamic effects shall not be less than 1.5 in Strength Load Combination I. The load factor for wind in Strength Load Combination III shall not be less than 1.25.

3.4.2.2—Evaluation of Deflection at the Service Limit State

In the absence of special provisions to the contrary, where evaluation of construction deflections are required by the contract documents, Load Combination Service I shall apply. Construction dead loads shall be considered as part of the permanent load and construction transient loads considered part of the live load. The associated permitted deflections shall be included in the contract documents.

The most common applications of prestressed concrete in steel girder bridges are transverse post-tensioning of the deck and integral pier caps in which the tendons penetrate the girder webs. When a composite deck is prestressed longitudinally, the shear connectors transfer force to the steel. The effect of shrinkage and long-term creep around the shear connectors should be evaluated to ensure that the composite girder is able to recognize the prestressing over the life of the bridge. The contribution of long-term deformations in closure pours between precast deck panels which have been aged to reduce shrinkage and creep may need evaluation.

The Poisson effect recognizes the bulging of concrete when subjected to prestressing. When used in pier caps, post-tensioning causes a transverse Poisson tensile stress resulting in a longitudinal stress in the steel girders.

A load factor for passive lateral earth pressure is not given in Table 3.4.1-2 because, strictly speaking, passive lateral earth pressure is a resistance and not a load. For discussion of the selection of a passive lateral earth pressure resistance factor see Article 10.5.5.2.2.

Blast loads are considered an Extreme Event case of loading. However, not enough information exists at the time of this writing to determine what other loads should be combined with blast loads and the appropriate load factors.

C3.4.2.1

The load factors presented here should not relieve the contractor of responsibility for safety and damage control during construction.

Construction loads are permanent loads and other loads that act on the structure only during construction. Construction loads include the weight of equipment such as deck finishing machines or loads applied to the structure through falsework or other temporary supports. Often the construction loads are not accurately known at design time; however, the magnitude and location of these loads considered in the design should be noted on the contract documents.

3.4.3—Load Factors for Jacking and Post-Tensioning Forces

3.4.3.1—Jacking Forces

Unless otherwise specified by the Owner, the design forces for jacking in service shall not be less than 1.3 times the permanent load reaction at the bearing, adjacent to the point of jacking.

Where the bridge will not be closed to traffic during the jacking operation, the jacking load shall also contain a live load reaction consistent with the maintenance of traffic plan, multiplied by the load factor for live load.

3.4.3.2—Force for Post-Tensioning Anchorage Zones

The design force for post-tensioning anchorage zones shall be taken as 1.2 times the maximum jacking force.

3.4.4—Load Factors for Orthotropic Decks

The Fatigue I live load factor (γ_{LL}) shall be multiplied by an additional factor of 1.5 when evaluating fatigue at the welded rib-to-floorbeam cut-out detail and the rib-to-deck weld.

C3.4.4

Evaluation of the maximum stress range in the rib-to-deck weld as well as in the vicinity of the cut-out for this type of detail has demonstrated that the use of a 1.5 load factor for LL is unconservative. For the rib-to-deck weld and when a cut-out is used to relieve the secondary stresses imparted by the rotation of the rib relative to the floorbeam, the appropriate γ_{LL} should be increased to 2.25 (Connor, 2002). The increased Fatigue I load factor is based on stress range spectra monitoring of orthotropic decks. Studies indicate that the ratio of maximum stress range to effective stress range is increased as compared to standard bridge girders. This is due to a number of factors such as occasional heavy wheels and reduced local load distribution that occurs in deck elements. These Specifications produce a ratio that is consistent with the original findings of NCHRP Report 299 (Moses et al., 1987).

3.5—PERMANENT LOADS

3.5.1—Dead Loads: DC , DW , and EV

Dead load shall include the weight of all components of the structure, appurtenances and utilities attached thereto, earth cover, wearing surface, future overlays, and planned widenings.

In the absence of more precise information, the unit weights, specified in Table 3.5.1-1, may be used for dead loads.

C3.5.1

Table 3.5.1-1 provides traditional unit weights. The unit weight of granular materials depends upon the degree of compaction and water content. The unit weight of concrete is primarily affected by the unit weight of the aggregate, which varies by geographical location and increases with concrete compressive strength. The unit weight of reinforced concrete is generally taken as 0.005 kcf greater than the unit weight of plain concrete. The values provided for wood include the weight of mandatory preservatives. The weight of transit rails, etc., is to be used only for preliminary design.

Table 3.5.1-1—Unit Weights

Material		Unit Weight (kef)
Aluminum Alloys		0.175
Bituminous Wearing Surfaces		0.140
Cast Iron		0.450
Cinder Filling		0.060
Compacted Sand, Silt, or Clay		0.120
Concrete	Lightweight	0.110
	Sand-Lightweight	0.120
	Normal Weight with $f'_c \leq 5.0$ ksi	0.145
	Normal Weight with $5.0 < f'_c \leq 15.0$ ksi	$0.140 + 0.001 f'_c$
Loose Sand, Silt, or Gravel		0.100
Soft Clay		0.100
Rolled Gravel, Macadam, or Ballast		0.140
Steel		0.490
Stone Masonry		0.170
Wood	Hard	0.060
	Soft	0.050
Water	Fresh	0.0624
	Salt	0.0640
Item		Weight per Unit Length (klf)
Transit Rails, Ties, and Fastening per Track		0.200

3.5.2—Earth Loads: *EH*, *ES*, and *DD*

Earth pressure, earth surcharge, and downdrag loads shall be as specified in Article 3.11.

3.6—LIVE LOADS

3.6.1—Gravity Loads: *LL* and *PL*

3.6.1.1—Vehicular Live Load

3.6.1.1.1—Number of Design Lanes

C3.6.1.1.1

Generally, the number of design lanes should be determined by taking the integer part of the ratio $w/12.0$, where w is the clear roadway width in ft between curbs and/or barriers. Possible future changes in the physical or functional clear roadway width of the bridge should be considered.

In cases where the traffic lanes are less than 12.0 ft wide, the number of design lanes shall be equal to the number of traffic lanes, and the width of the design lane shall be taken as the width of the traffic lane.

Roadway widths from 20.0 to 24.0 ft shall have two design lanes, each equal to one-half the roadway width.

It is not the intention of this Article to promote bridges with narrow traffic lanes. Wherever possible, bridges should be built to accommodate the standard design lane and appropriate shoulders.

3.6.1.1.2—Multiple Presence of Live Load

C3.6.1.1.2

The provisions of this Article shall not be applied to the fatigue limit state for which one design truck is used, regardless of the number of design lanes. Where the single-lane approximate distribution factors in Articles 4.6.2.2 and 4.6.2.3 are used, other than the lever rule and statical method, the force effects shall be divided by 1.20.

Unless specified otherwise herein, the extreme live load force effect shall be determined by considering each possible combination of number of loaded lanes multiplied by a corresponding multiple presence factor to account for the probability of simultaneous lane occupation by the full HL93 design live load. In lieu of site specific data, the values in Table 3.6.1.1.2-1:

- Shall be used when investigating the effect of one lane loaded,
- May be used when investigating the effect of three or more lanes loaded.

For the purpose of determining the number of lanes when the loading condition includes the pedestrian loads specified in Article 3.6.1.6 combined with one or more lanes of the vehicular live load, the pedestrian loads may be taken to be one loaded lane.

The factors specified in Table 3.6.1.1.2-1 shall not be applied in conjunction with approximate load distribution factors specified in Articles 4.6.2.2 and 4.6.2.3, except where the lever rule is used or where special requirements for exterior beams in beam-slab bridges, specified in Article 4.6.2.2.2d, are used.

Table 3.6.1.1.2-1—Multiple Presence Factors, *m*

Number of Loaded Lanes	Multiple Presence Factors, <i>m</i>
1	1.20
2	1.00
3	0.85
>3	0.65

The multiple presence factors have been included in the approximate equations for distribution factors in Articles 4.6.2.2 and 4.6.2.3, both for single and multiple lanes loaded. The equations are based on evaluation of several combinations of loaded lanes with their appropriate multiple presence factors and are intended to account for the worst case scenario. Where use of the lever rule is specified in Article 4.6.2.2 and 4.6.2.3, the Engineer must determine the number and location of vehicles and lanes, and, therefore, must include the multiple presence. Stated another way, if a sketch is required to determine load distribution, the Engineer is responsible for including multiple presence factors and selecting the worst design case. The factor 1.20 from Table 3.6.1.1.2-1 has already been included in the approximate equations and should be removed for the purpose of fatigue investigations.

The entry greater than 1.0 in Table 3.6.1.1.2-1 results from statistical calibration of these Specifications on the basis of pairs of vehicles instead of a single vehicle. Therefore, when a single vehicle is on the bridge, it can be heavier than each one of a pair of vehicles and still have the same probability of occurrence.

The consideration of pedestrian loads counting as a “loaded lane” for the purpose of determining a multiple presence factor (*m*) is based on the assumption that simultaneous occupancy by a dense loading of people combined with a 75-yr design live load is remote. For the purpose of this provision, it has been assumed that if a bridge is used as a viewing stand for eight hours each year for a total time of about one month, the appropriate live load to combine with it would have a one-month recurrence interval. This is reasonably approximated by use of the multiple presence factors, even though they are originally developed for vehicular live load.

Thus, if a component supported a sidewalk and one lane, it would be investigated for the vehicular live load alone with *m* = 1.20, and for the pedestrian loads combined with the vehicular live load with *m* = 1.0. If a component supported a sidewalk and two lanes of vehicular live load, it would be investigated for:

- One lane of vehicular live load, *m* = 1.20;
- The greater of the more significant lanes of vehicular live load and the pedestrian loads or two lanes of vehicular live load, *m* = 1.0, applied to the governing case; and
- Two lanes of vehicular live load and the pedestrian loads, *m* = 0.85.

The multiple presence factor of 1.20 for a single lane does not apply to the pedestrian loads. Therefore, the case of the pedestrian loads without the vehicular live load is a subset of the second bulleted item.

The multiple presence factors in Table 3.6.1.1.2-1 were developed on the basis of an ADTT of 5,000 trucks in one direction. The force effect resulting from the appropriate number of lanes may be reduced for sites with lower ADTT as follows:

- If $100 \leq ADTT \leq 1,000$, 95 percent of the specified force effect may be used; and
- If $ADTT < 100$, 90 percent of the specified force effect may be used.

This adjustment is based on the reduced probability of attaining the design event during a 75-year design life with reduced truck volume.

3.6.1.2—Design Vehicular Live Load

3.6.1.2.1—General

Vehicular live loading on the roadways of bridges or incidental structures, designated HL-93, shall consist of a combination of the:

- Design truck or design tandem, and
- Design lane load.

Except as modified in Article 3.6.1.3.1, each design lane under consideration shall be occupied by either the design truck or tandem, coincident with the lane load, where applicable. The loads shall be assumed to occupy 10.0 ft transversely within a design lane.

C3.6.1.2.1

Consideration should be given to site-specific modifications to the design truck, design tandem, and/or the design lane load under the following conditions:

- The legal load of a given jurisdiction is significantly greater than typical;
- The roadway is expected to carry unusually high percentages of truck traffic;
- Flow control, such as a stop sign, traffic signal, or toll booth, causes trucks to collect on certain areas of a bridge or to not be interrupted by light traffic; or
- Special industrial loads are common due to the location of the bridge.

See also discussion in Article C3.6.1.3.1.

The live load model, consisting of either a truck or tandem coincident with a uniformly distributed load, was developed as a notional representation of shear and moment produced by a group of vehicles routinely permitted on highways of various states under “grandfather” exclusions to weight laws. The vehicles considered to be representative of these exclusions were based on a study conducted by the Transportation Research Board (Cohen, 1990). The load model is called “notional” because it is not intended to represent any particular truck.

In the initial development of the notional live load model, no attempt was made to relate to escorted permit loads, illegal overloads, or short duration special permits. The moment and shear effects were subsequently compared to the results of truck weight studies (Csagoly and Knobel, 1981; Nowak, 1992), selected WIM data, and the 1991 OHBDC live load model. These subsequent comparisons showed that the notional load could be scaled by appropriate load factors to be representative of these other load spectra.

The following nomenclature applies to Figures C3.6.1.2.1-1 through C3.6.1.2.1-6, which show results of live load studies involving two equal continuous spans or simple spans:

$M_{POS\ 0.4L}$	=	positive moment at 4/10 point in either span
$M_{NEG\ 0.4L}$	=	negative moment at 4/10 point in either span
$M_{SUPPORT}$	=	moment at interior support
V_{ab}	=	shear adjacent to either exterior support
V_{ba}	=	shear adjacent to interior support
M_{ss}	=	midspan moment in a simply supported span

The “span” is the length of the simple-span or of one of each of the two continuous spans. The comparison is in the form of ratios of the load effects produced in either simple-span or two-span continuous girders. A ratio greater than 1.0 indicates that one or more of the exclusion vehicles produces a larger load effect than the HS20 loading. The figures indicate the degree by which the exclusion loads deviate from the HS loading of designation, e.g., HS25.

Figures C3.6.1.2.1-1 and C3.6.1.2.1-2 show moment and shear comparisons between the envelope of effects caused by 22 truck configurations chosen to be representative of the exclusion vehicles and the HS20 loading, either the HS20 truck or the lane load, or the interstate load consisting of two 24.0-kip axles 4.0 ft apart, as used in previous editions of the AASHTO Standard Specifications. The largest and smallest of the 22 configurations can be found in Kulicki and Mertz (1991). In the case of negative moment at an interior support, the results presented are based on two identical exclusion vehicles in tandem and separated by at least 50.0 ft.

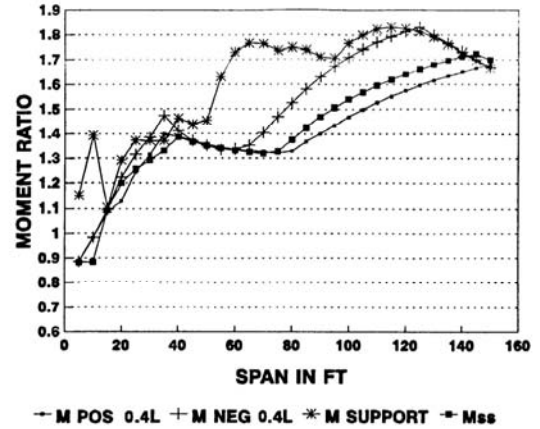

Figure C3.6.1.2.1-1—Moment Ratios: Exclusion Vehicles to HS20 (truck or lane) or Two 24.0-kip Axles at 4.0 ft

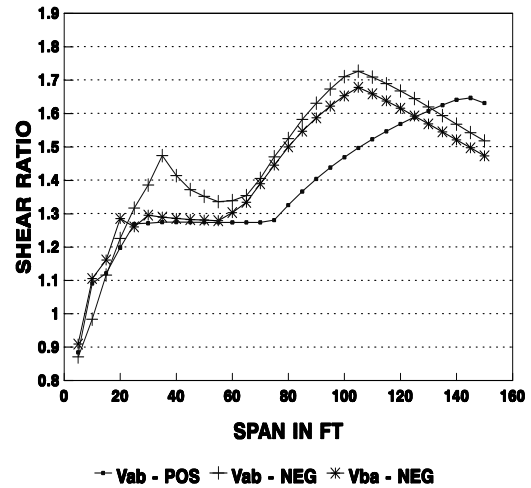

Figure C3.6.1.2.1-2—Shear Ratios: Exclusion Vehicles to HS20 (truck or lane) or Two 24.0-kip Axles at 4.0 ft

Figures C3.6.1.2.1-3 and C3.6.1.2.1-4 show comparisons between the force effects produced by a single exclusion truck per lane and the notional load model, except for negative moment, where the tandem exclusion vehicles were used. In the case of negative moment at a support, the provisions of Article 3.6.1.3.1 requiring investigation of 90 percent of the effect of two design trucks, plus 90 percent of the design lane load, has been included in Figures C3.6.1.2.1-3 and C3.6.1.2.1-5. Compared with Figures C3.6.1.2.1-1 and C3.6.1.2.1-2, the range of ratios can be seen as more closely grouped:

- Over the span range,
- Both for shear and moment, and
- Both for simple-span and continuous spans.

The implication of close grouping is that the notional load model with a single-load factor has general applicability.

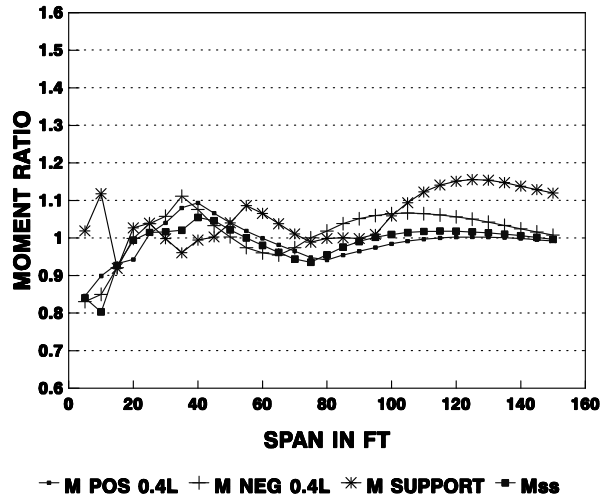

Figure C3.6.1.2.1-3—Moment Ratios: Exclusion Vehicles to Notional Model

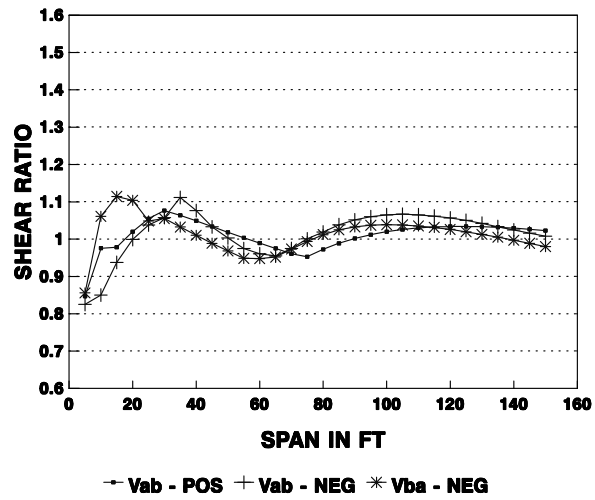

Figure C3.6.1.2.1-4—Shear Ratios: Exclusion Vehicles to Notional Model

Figures C3.6.1.2.1-5 and C3.6.1.2.1-6 show the ratios of force effects produced by the notional load model and the greatest of the HS20 truck or lane loading, or Alternate Military Loading.

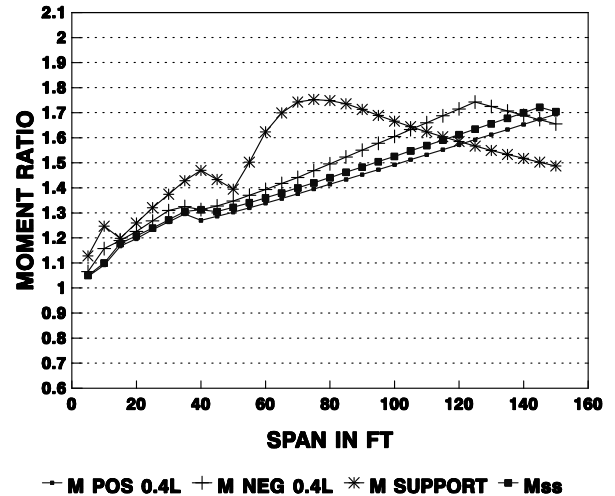

Figure C3.6.1.2.1-5—Moment Ratios: Notional Model to HS20 (truck or lane) or Two 24.0-kip Axles at 4.0 ft

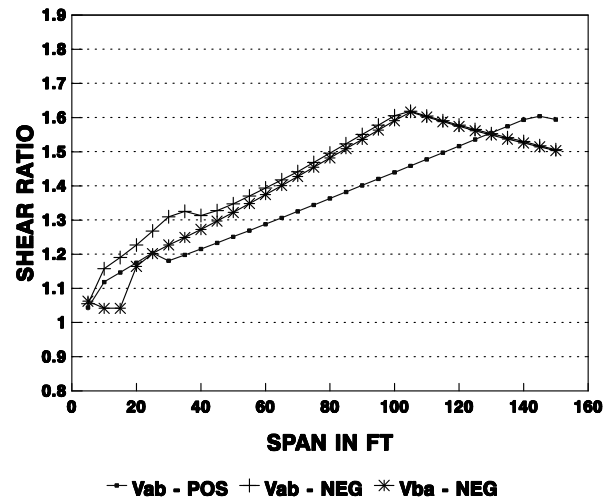

Figure C3.6.1.2.1-6—Shear Ratios: Notional Model to HS20 (truck and lane) or Two 24.0-kip Axles at 4.0 ft

In reviewing Figures C3.6.1.2.1-5 and C3.6.1.2.1-6, it should be noted that the total design force effect is also a function of load factor, load modifier, load distribution, and dynamic load allowance.

3.6.1.2.2—Design Truck

The weights and spacings of axles and wheels for the design truck shall be as specified in Figure 3.6.1.2.2-1. A dynamic load allowance shall be considered as specified in Article 3.6.2.

Except as specified in Articles 3.6.1.3.1 and 3.6.1.4.1, the spacing between the two 32.0-kip axles shall be varied between 14.0 ft and 30.0 ft to produce extreme force effects.

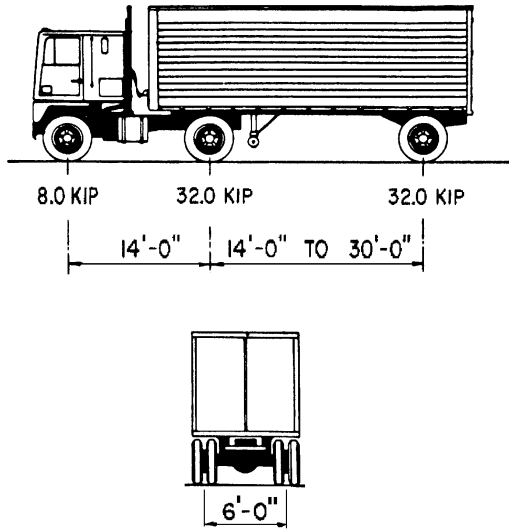

Figure 3.6.1.2.2-1—Characteristics of the Design Truck

3.6.1.2.3—Design Tandem

The design tandem shall consist of a pair of 25.0-kip axles spaced 4.0 ft apart. The transverse spacing of wheels shall be taken as 6.0 ft. A dynamic load allowance shall be considered as specified in Article 3.6.2.

3.6.1.2.4—Design Lane Load

The design lane load shall consist of a load of 0.64 klf uniformly distributed in the longitudinal direction. Transversely, the design lane load shall be assumed to be uniformly distributed over a 10.0-ft width. The force effects from the design lane load shall not be subject to a dynamic load allowance.

3.6.1.2.5—Tire Contact Area

The tire contact area of a wheel consisting of one or two tires shall be assumed to be a single rectangle, whose width is 20.0 in. and whose length is 10.0 in.

The tire pressure shall be assumed to be uniformly distributed over the contact area. The tire pressure shall be assumed to be distributed as follows:

- On continuous surfaces, uniformly over the specified contact area, and
- On interrupted surfaces, uniformly over the actual contact area within the footprint with the pressure increased in the ratio of the specified to actual contact areas.

For the design of orthotropic decks and wearing surfaces on orthotropic decks, the front wheels shall be assumed to be a single rectangle whose width and length are both 10.0 in. as specified in Article 3.6.1.4.1.

C3.6.1.2.5

The area load applies only to the design truck and tandem. For other design vehicles, the tire contact area should be determined by the engineer.

As a guideline for other truck loads, the tire area in in.² may be calculated from the following dimensions:

Tire width = $P/0.8$

Tire length = $6.4\gamma(1 + IM/100)$

where:

- γ = load factor
- IM = dynamic load allowance percent
- P = design wheel load (kip)

3.6.1.2.6—Distribution of Wheel Loads through Earth Fills

Where the depth of fill is less than 2.0 ft, live loads shall be distributed to the top slabs of culverts as specified in Article 4.6.2.10.

In lieu of a more precise analysis, or the use of other acceptable approximate methods of load distribution permitted in Section 12, where the depth of fill is 2.0 ft or greater, wheel loads may be considered to be uniformly distributed over a rectangular area with sides equal to the dimension of the tire contact area, as specified in Article 3.6.1.2.5, and increased by either 1.15 times the depth of the fill in select granular backfill, or the depth of the fill in all other cases. The provisions of Articles 3.6.1.1.2 and 3.6.1.3 shall apply.

Where such areas from several wheels overlap, the total load shall be uniformly distributed over the area.

For single-span culverts, the effects of live load may be neglected where the depth of fill is more than 8.0 ft and exceeds the span length; for multiple span culverts, the effects may be neglected where the depth of fill exceeds the distance between faces of end walls.

Where the live load and impact moment in concrete slabs, based on the distribution of the wheel load through earth fills, exceeds the live load and impact moment calculated according to Article 4.6.2.10, the latter moment shall be used.

3.6.1.3—Application of Design Vehicular Live Loads

3.6.1.3.1—General

Unless otherwise specified, the extreme force effect shall be taken as the larger of the following:

- The effect of the design tandem combined with the effect of the design lane load, or
- The effect of one design truck with the variable axle spacing specified in Article 3.6.1.2.2, combined with the effect of the design lane load, and

C3.6.1.2.6

Elastic solutions for pressures produced within an infinite half-space by loads on the ground surface can be found in Poulos and Davis (1974), NAVFAC DM-7.1 (1982), and soil mechanics textbooks.

This approximation is similar to the 60-degree rule found in many texts on soil mechanics. The dimensions of the tire contact area are determined at the surface based on the dynamic load allowance of 33 percent at depth = 0. They are projected through the soil as specified. The pressure intensity on the surface is based on the wheel load without dynamic load allowance. A dynamic load allowance is added to the pressure on the projected area. The dynamic load allowance also varies with depth as specified in Article 3.6.2.2. The design lane load is applied where appropriate and multiple presence factors apply.

This provision applies to relieving slabs below grade and to top slabs of box culverts.

Traditionally, the effect of fills less than 2.0 ft deep on live load has been ignored. Research (McGrath, et al. 2004) has shown that in design of box sections allowing distribution of live load through fill in the direction parallel to the span provides a more accurate design model to predict moment, thrust, and shear forces. Provisions in Article 4.6.2.10 provide a means to address the effect of shallow fills.

C3.6.1.3.1

The effects of an axle sequence and the lane load are superposed in order to obtain extreme values. This is a deviation from the traditional AASHTO approach, in which either the truck or the lane load, with an additional concentrated load, provided for extreme effects.

The lane load is not interrupted to provide space for the axle sequences of the design tandem or the design truck; interruption is needed only for patch loading patterns to produce extreme force effects.

- For negative moment between points of contraflexure under a uniform load on all spans, and reaction at interior piers only, 90 percent of the effect of two design trucks spaced a minimum of 50.0 ft between the lead axle of one truck and the rear axle of the other truck, combined with 90 percent of the effect of the design lane load. The distance between the 32.0-kip axles of each truck shall be taken as 14.0 ft. The two design trucks shall be placed in adjacent spans to produce maximum force effects.

Axles that do not contribute to the extreme force effect under consideration shall be neglected.

Both the design lanes and the 10.0-ft loaded width in each lane shall be positioned to produce extreme force effects. The design truck or tandem shall be positioned transversely such that the center of any wheel load is not closer than:

- For the design of the deck overhang—1.0 ft from the face of the curb or railing, and
- For the design of all other components—2.0 ft from the edge of the design lane.

Unless otherwise specified, the lengths of design lanes, or parts thereof, that contribute to the extreme force effect under consideration, shall be loaded with the design lane load.

3.6.1.3.2—Loading for Optional Live Load Deflection Evaluation

If the Owner invokes the optional live load deflection criteria specified in Article 2.5.2.6.2, the deflection should be taken as the larger of:

- That resulting from the design truck alone, or
- That resulting from 25 percent of the design truck taken together with the design lane load.

The notional design loads were based on the information described in Article C3.6.1.2.1, which contained data on “low boy” type vehicles weighing up to about 110 kip. Where multiple lanes of heavier versions of this type of vehicle are considered probable, consideration should be given to investigating negative moment and reactions at interior supports for pairs of the design tandem spaced from 26.0 ft to 40.0 ft apart, combined with the design lane load specified in Article 3.6.1.2.4. The design tandems should be placed in adjacent spans to produce maximum force effect. One hundred percent of the combined effect of the design tandems and the design lane load should be used. This is consistent with Article 3.6.1.2.1 and should not be considered a replacement for the Strength II Load Combination.

Only those areas or parts of areas that contribute to the same extreme being sought should be loaded. The loaded length should be determined by the points where the influence surface meets the centerline of the design lane.

Where a sidewalk is not separated from the roadway by a crashworthy traffic barrier, consideration should be given to the possibility that vehicles can mount the sidewalk.

C3.6.1.3.2

As indicated in C2.5.2.6.1, live load deflection is a service issue, not a strength issue. Experience with bridges designed under previous editions of the AASHTO Standard Specifications indicated no adverse effects of live load deflection per se. Therefore, there appears to be little reason to require that the past criteria be compared to a deflection based upon the heavier live load required by these Specifications.

The provisions of this Article are intended to produce apparent live load deflections similar to those used in the past. The current design truck is identical to the HS20 truck of past Standard Specifications. For the span lengths where the design lane load controls, the design lane load together with 25 percent of the design truck, i.e., three concentrated loads totaling 18.0 kip, is similar to the past lane load with its single concentrated load of 18.0 kip.

*3.6.1.3.3—Design Loads for Decks, Deck Systems,
and the Top Slabs of Box Culverts*

The provisions of this Article shall not apply to decks designed under the provisions of Article 9.7.2, “Empirical Design.”

Where the approximate strip method is used to analyze decks and top slabs of culverts, force effects shall be determined on the following basis:

- Where the slab spans primarily in the transverse direction, only the axles of the design truck of Article 3.6.1.2.2 or design tandem of Article 3.6.1.2.3 shall be applied to the deck slab or the top slab of box culverts.
- Where the slab spans primarily in the longitudinal direction:
 - For top slabs of box culverts of all spans and for all other cases, including slab-type bridges where the span does not exceed 15.0 ft, only the axle loads of the design truck or design tandem of Articles 3.6.1.2.2 and 3.6.1.2.3, respectively, shall be applied.
 - For all other cases, including slab-type bridges (excluding top slabs of box culverts) where the span exceeds 15.0 ft, all of the load specified in Article 3.6.1.2 shall be applied.

Where the refined methods are used to analyze decks, force effects shall be determined on the following basis:

- Where the slab spans primarily in the transverse direction, only the axles of the design truck of Article 3.6.1.2.2 or design tandem of Article 3.6.1.2.3 shall be applied to the deck slab.
- Where the slab spans primarily in the longitudinal direction (including slab-type bridges), all of the loads specified in Article 3.6.1.2 shall be applied.

Wheel loads shall be assumed to be equal within an axle unit, and amplification of the wheel loads due to centrifugal and braking forces need not be considered for the design of decks.

C3.6.1.3.3

This Article clarifies the selection of wheel loads to be used in the design of bridge decks, slab bridges, and top slabs of box culverts.

The design load is always an axle load; single wheel loads should not be considered.

The design truck and tandem without the lane load and with a multiple presence factor of 1.2 results in factored force effects that are similar to the factored force effects using earlier specifications for typical span ranges of box culverts.

Individual Owners may choose to develop other axle weights and configurations to capture the load effects of the actual loads in their jurisdiction based upon local legal-load and permitting policies. Triple axle configurations of single unit vehicles have been observed to have load effects in excess of the HL-93 tandem axle load.

It is theoretically possible that an extreme force effect could result from a 32.0-kip axle in one lane and a 50.0-kip tandem in a second lane, but such sophistication is not warranted in practical design.

3.6.1.3.4—Deck Overhang Load

For the design of deck overhangs with a cantilever, not exceeding 6.0 ft from the centerline of the exterior girder to the face of a structurally continuous concrete railing, the outside row of wheel loads may be replaced with a uniformly distributed line load of 1.0 klf intensity, located 1.0 ft from the face of the railing.

Horizontal loads on the overhang resulting from vehicle collision with barriers shall be in accordance with the provisions of Section 13.

3.6.1.4—Fatigue Load

3.6.1.4.1—Magnitude and Configuration

The fatigue load shall be one design truck or axles thereof specified in Article 3.6.1.2.2, but with a constant spacing of 30.0 ft between the 32.0-kip axles.

The dynamic load allowance specified in Article 3.6.2 shall be applied to the fatigue load.

For the design of orthotropic decks and wearing surfaces on orthotropic decks, the loading pattern as shown in Figure 3.6.1.4.1-1 shall be used.

C3.6.1.3.4

Structurally continuous barriers have been observed to be effective in distributing wheel loads in the overhang. Implicit in this provision is the assumption that the 25.0-kip half weight of a design tandem is distributed over a longitudinal length of 25.0 ft, and that there is a cross beam or other appropriate component at the end of the bridge supporting the barrier which is designed for the half tandem weight. This provision does not apply if the barrier is not structurally continuous.

C3.6.1.4.1

For orthotropic steel decks, the governing 16.0-kip wheel loads should be modeled in more detail as two closely spaced 8.0-kip wheels 4.0 ft apart to more accurately reflect a modern tractor-trailer with tandem rear axles. Further, these wheel loads should be distributed over the specified contact area (20.0 in. wide × 10.0 in. long for rear axles and 10.0 in. square for front axles), which better approximates actual pressures applied from a dual tire unit (Kulicki and Mertz, 2006; Nowak, 2008). Note that the smaller 10.0 in. × 10.0 in. front wheels can be the controlling load for fatigue design of many orthotropic deck details.

This loading should be positioned both longitudinally and transversely on the bridge deck, ignoring the striped lanes, to create the worst stress or deflection, as applicable.

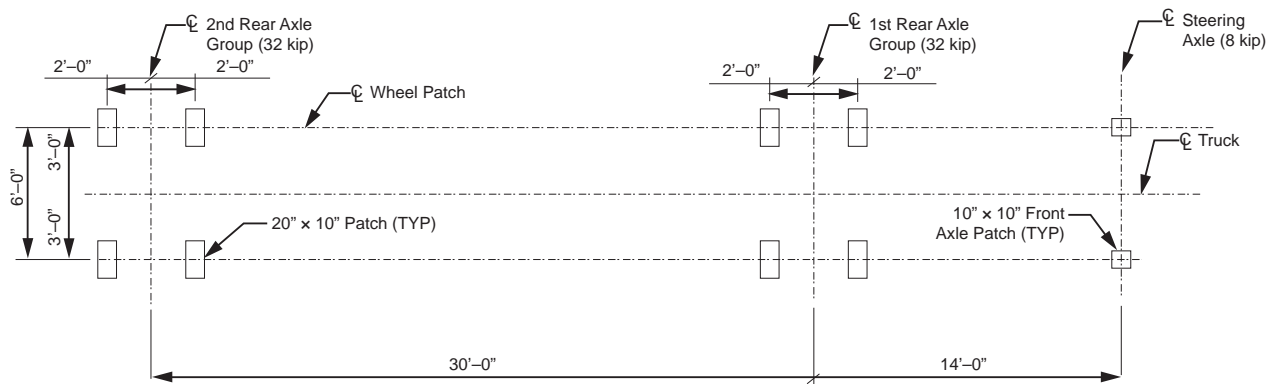

Figure 3.6.1.4.1-1—Refined Design Truck Footprint for Fatigue Design

3.6.1.4.2—Frequency

The frequency of the fatigue load shall be taken as the single-lane average daily truck traffic ($ADTT_{SL}$). This frequency shall be applied to all components of the bridge, even to those located under lanes that carry a lesser number of trucks.

In the absence of better information, the single-lane average daily truck traffic shall be taken as:

C3.6.1.4.2

Since the fatigue and fracture limit state is defined in terms of accumulated stress-range cycles, specification of load alone is not adequate. Load should be specified along with the frequency of load occurrence.

For the purposes of this Article, a truck is defined as any vehicle with more than either two axles or four wheels.

$$ADTT_{SL} = p \times ADTT \quad (3.6.1.4.2-1)$$

where:

- $ADTT$ = the number of trucks per day in one direction averaged over the design life
 $ADTT_{SL}$ = the number of trucks per day in a single-lane averaged over the design life
 p = fraction of traffic in a single lane, taken as specified in Table 3.6.1.4.2-1

The single-lane $ADTT$ is that for the traffic lane in which the majority of the truck traffic crosses the bridge. On a typical bridge with no nearby entrance/exit ramps, the shoulder lane carries most of the truck traffic. The frequency of the fatigue load for a single lane is assumed to apply to all lanes since future traffic patterns on the bridge are uncertain.

Consultation with traffic engineers regarding any directionality of truck traffic may lead to the conclusion that one direction carries more than one-half of the bidirectional $ADTT$. If such data is not available from traffic engineers, designing for 55 percent of the bidirectional $ADTT$ is suggested.

The value of $ADTT_{SL}$ is best determined in consultation with traffic engineers. However, traffic growth data is usually not predicted for the design life of the bridge, taken as 75 yr in these Specifications unless specified otherwise by the Owner. Techniques exist to extrapolate available data such as curve fitting growth rate vs. time and using extreme value distributions, but some judgment is required. Research has shown that the average daily traffic (ADT), including all vehicles, i.e., cars and trucks, is physically limited to about 20,000 vehicles per lane per day under normal conditions. This limiting value of traffic should be considered when estimating the $ADTT$. The $ADTT$ can be determined by multiplying the ADT by the fraction of trucks in the traffic. In lieu of site-specific fraction of truck traffic data, the values of Table C3.6.1.4.2-1 may be applied for routine bridges.

Table 3.6.1.4.2-1—Fraction of Truck Traffic in a Single Lane, p

Number of Lanes Available to Trucks	p
1	1.00
2	0.85
3 or more	0.80

Table C3.6.1.4.2-1—Fraction of Trucks in Traffic

Class of Highway	Fraction of Trucks in Traffic
Rural Interstate	0.20
Urban Interstate	0.15
Other Rural	0.15
Other Urban	0.10

3.6.1.4.3—Load Distribution for Fatigue

3.6.1.4.3a—Refined Methods

Where the bridge is analyzed by any refined method, as specified in Article 4.6.3, a single design truck shall be positioned transversely and longitudinally to maximize stress range at the detail under consideration, regardless of the position of traffic or design lanes on the deck.

3.6.1.4.3b—Approximate Methods

Where the bridge is analyzed by approximate load distribution, as specified in Article 4.6.2, the distribution factor for one traffic lane shall be used.

C3.6.1.4.3a

If it were assured that the traffic lanes would remain as they are indicated at the opening of the bridge throughout its entire service life, it would be more appropriate to place the truck at the center of the traffic lane that produces maximum stress range in the detail under consideration. But because future traffic patterns on the bridge are uncertain and in the interest of minimizing the number of calculations required of the Designer, the position of the truck is made independent of the location of both the traffic lanes and the design lanes.

3.6.1.5—Rail Transit Load

Where a bridge also carries rail-transit vehicles, the Owner shall specify the transit load characteristics and the expected interaction between transit and highway traffic.

3.6.1.6—Pedestrian Loads

A pedestrian load of 0.075 ksf shall be applied to all sidewalks wider than 2.0 ft and considered simultaneously with the vehicular design live load in the vehicle lane. Where vehicles can mount the sidewalk, sidewalk pedestrian load shall not be considered concurrently. If a sidewalk may be removed in the future, the vehicular live loads shall be applied at 1 ft from edge-of-deck for design of the overhang, and 2 ft from edge-of-deck for design of all other components. The pedestrian load shall not be considered to act concurrently with vehicles. The dynamic load allowance need not be considered for vehicles.

Bridges intended for only pedestrian, equestrian, light maintenance vehicle, and/or bicycle traffic should be designed in accordance with AASHTO's *LRFD Guide Specifications for the Design of Pedestrian Bridges*.

3.6.1.7—Loads on Railings

Loads on railings shall be taken as specified in Section 13.

3.6.2—Dynamic Load Allowance: *IM*

3.6.2.1—General

Unless otherwise permitted in Articles 3.6.2.2 and 3.6.2.3, the static effects of the design truck or tandem, other than centrifugal and braking forces, shall be increased by the percentage specified in Table 3.6.2.1-1 for dynamic load allowance.

The factor to be applied to the static load shall be taken as: $(1 + IM/100)$.

The dynamic load allowance shall not be applied to pedestrian loads or to the design lane load.

C3.6.1.5

If rail transit is designed to occupy an exclusive lane, transit loads should be included in the design, but the bridge should not have less strength than if it had been designed as a highway bridge of the same width.

If the rail transit is supposed to mix with regular highway traffic, the Owner should specify or approve an appropriate combination of transit and highway loads for the design.

Transit load characteristics may include:

- Loads,
- Load distribution,
- Load frequency,
- Dynamic allowance, and
- Dimensional requirements.

C3.6.1.6

See the provisions of Article C3.6.1.1.2 for applying the pedestrian loads in combination with the vehicular live load.

C3.6.2.1

Page (1976) contains the basis for some of these provisions.

The dynamic load allowance (*IM*) in Table 3.6.2.1-1 is an increment to be applied to the static wheel load to account for wheel load impact from moving vehicles.

Dynamic effects due to moving vehicles may be attributed to two sources:

- Hammering effect is the dynamic response of the wheel assembly to riding surface discontinuities, such as deck joints, cracks, potholes, and delaminations, and

Table 3.6.2.1-1—Dynamic Load Allowance, *IM*

Component	IM
Deck Joints—All Limit States	75%
All Other Components:	
• Fatigue and Fracture Limit State	15%
• All Other Limit States	33%

The application of dynamic load allowance for buried components, covered in Section 12, shall be as specified in Article 3.6.2.2.

Dynamic load allowance need not be applied to:

- Retaining walls not subject to vertical reactions from the superstructure, and
- Foundation components that are entirely below ground level.

The dynamic load allowance may be reduced for components, other than joints, if justified by sufficient evidence, in accordance with the provisions of Article 4.7.2.1.

- Dynamic response of the bridge as a whole to passing vehicles, which may be due to long undulations in the roadway pavement, such as those caused by settlement of fill, or to resonant excitation as a result of similar frequencies of vibration between bridge and vehicle.

Field tests indicate that in the majority of highway bridges, the dynamic component of the response does not exceed 25 percent of the static response to vehicles. This is the basis for dynamic load allowance with the exception of deck joints. However, the specified live load combination of the design truck and lane load, represents a group of exclusion vehicles that are at least 4/3 of those caused by the design truck alone on short- and medium-span bridges. The specified value of 33 percent in Table 3.6.2.1-1 is the product of 4/3 and the basic 25 percent.

Generally speaking, the dynamic amplification of trucks follows the following general trends:

- As the weight of the vehicle goes up, the apparent amplification goes down.
- Multiple vehicles produce a lower dynamic amplification than a single vehicle.
- More axles result in a lower dynamic amplification.

For heavy permit vehicles which have many axles compared to the design truck, a reduction in the dynamic load allowance may be warranted. A study of dynamic effects presented in a report by the Calibration Task Group (*Nowak 1992*) contains details regarding the relationship between dynamic load allowance and vehicle configuration.

This Article recognizes the damping effect of soil when in contact with some buried structural components, such as footings. To qualify for relief from impact, the entire component must be buried. For the purpose of this Article, a retaining type component is considered to be buried to the top of the fill.

3.6.2.2—Buried Components

The dynamic load allowance for culverts and other buried structures covered by Section 12, in percent, shall be taken as:

$$IM = 33(1.0 - 0.125D_E) \geq 0\% \quad (3.6.2.2-1)$$

where:

D_E = the minimum depth of earth cover above the structure (ft)

3.6.2.3—Wood Components

Dynamic load allowance need not be applied to wood components.

3.6.3—Centrifugal Forces: *CE*

For the purpose of computing the radial force or the overturning effect on wheel loads, the centrifugal effect on live load shall be taken as the product of the axle weights of the design truck or tandem and the factor C , taken as:

$$C = f \frac{v^2}{gR} \quad (3.6.3-1)$$

where:

- v = highway design speed (ft/s)
- f = 4/3 for load combinations other than fatigue and 1.0 for fatigue
- g = gravitational acceleration: 32.2 (ft/s²)
- R = radius of curvature of traffic lane (ft)

Highway design speed shall not be taken to be less than the value specified in the current edition of the AASHTO publication, *A Policy of Geometric Design of Highways and Streets*.

The multiple presence factors specified in Article 3.6.1.1.2 shall apply.

Centrifugal forces shall be applied horizontally at a distance 6.0 ft above the roadway surface. A load path to carry the radial force to the substructure shall be provided.

The effect of superelevation in reducing the overturning effect of centrifugal force on vertical wheel loads may be considered.

3.6.4—Braking Force: *BR*

The braking force shall be taken as the greater of:

- 25 percent of the axle weights of the design truck or design tandem or,
- Five percent of the design truck plus lane load or five percent of the design tandem plus lane load

C3.6.2.3

Wood structures are known to experience reduced dynamic wheel load effects due to internal friction between the components and the damping characteristics of wood. Additionally, wood is stronger for short duration loads, as compared to longer duration loads. This increase in strength is greater than the increase in force effects resulting from the dynamic load allowance.

C3.6.3

Centrifugal force is not required to be applied to the design lane load, as the spacing of vehicles at high speed is assumed to be large, resulting in a low density of vehicles following and/or preceding the design truck. For all other consideration of live load other than for fatigue, the design lane load is still considered even though the centrifugal effect is not applied to it.

The specified live load combination of the design truck and lane load, however, represents a group of exclusion vehicles that produce force effects of at least 4/3 of those caused by the design truck alone on short- and medium-span bridges. This ratio is indicated in Eq. 3.6.3-1 for the service and strength limit states. For the fatigue and fracture limit state, the factor 1.0 is consistent with cumulative damage analysis. The provision is not technically perfect, yet it reasonably models the representative exclusion vehicle traveling at design speed with large headways to other vehicles. The approximation attributed to this convenient representation is acceptable in the framework of the uncertainty of centrifugal force from random traffic patterns.

$$1.0 \text{ ft/s} = 0.682 \text{ mph}$$

Centrifugal force also causes an overturning effect on the wheel loads because the radial force is applied 6.0 ft above the top of the deck. Thus, centrifugal force tends to cause an increase in the vertical wheel loads toward the outside of the bridge and an unloading of the wheel loads toward the inside of the bridge. Superelevation helps to balance the overturning effect due to the centrifugal force and this beneficial effect may be considered. The effects due to vehicle cases with centrifugal force effects included should be compared to the effects due to vehicle cases with no centrifugal force, and the worst case selected.

C3.6.4

Based on energy principles, and assuming uniform deceleration, the braking force determined as a fraction of vehicle weight is:

$$b = \frac{v^2}{2ga} \quad (C3.6.4-1)$$

This braking force shall be placed in all design lanes which are considered to be loaded in accordance with Article 3.6.1.1.1 and which are carrying traffic headed in the same direction. These forces shall be assumed to act horizontally at a distance of 6.0 ft above the roadway surface in either longitudinal direction to cause extreme force effects. All design lanes shall be simultaneously loaded for bridges likely to become one-directional in the future.

The multiple presence factors specified in Article 3.6.1.1.2 shall apply.

where a is the length of uniform deceleration and b is the fraction. Calculations using a braking length of 400 ft and a speed of 55 mph yield $b = 0.25$ for a horizontal force that will act for a period of about 10 s. The factor b applies to all lanes in one direction because all vehicles may have reacted within this time frame.

For short- and medium-span bridges, the specified braking force can be significantly larger than was required in the Standard Specifications. The braking force specified in the Standard Specifications dates back to at least the early 1940's without any significant changes to address the improved braking capacity of modern trucks. A review of other bridge design codes in Canada and Europe showed that the braking force required by the Standard Specification is much lower than that specified in other design codes for most typical bridges. One such comparison is shown in Figure C3.6.4-1.

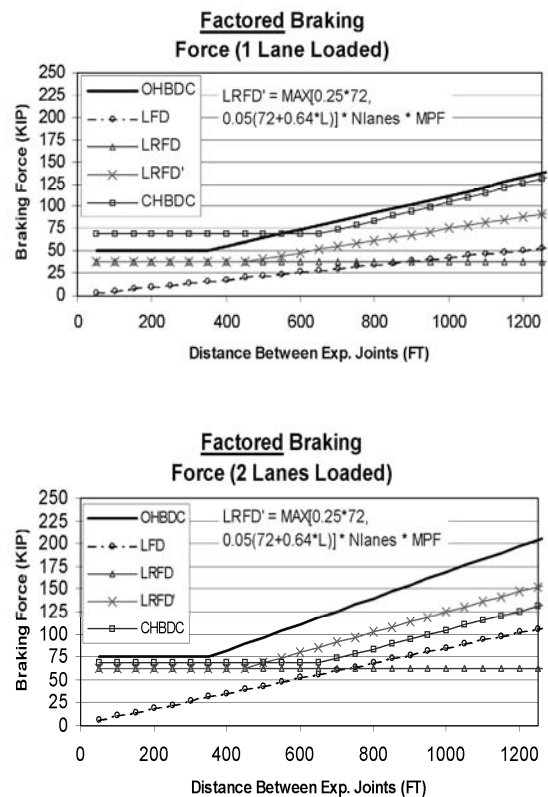

Figure C3.6.4-1—Comparison of Braking Force Models

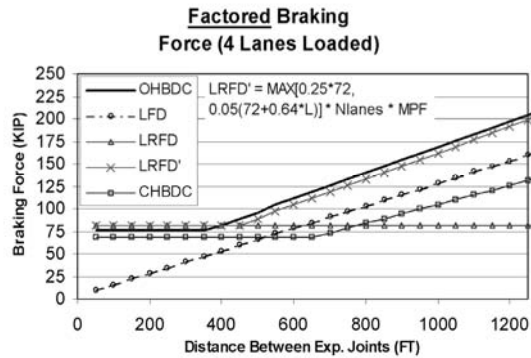
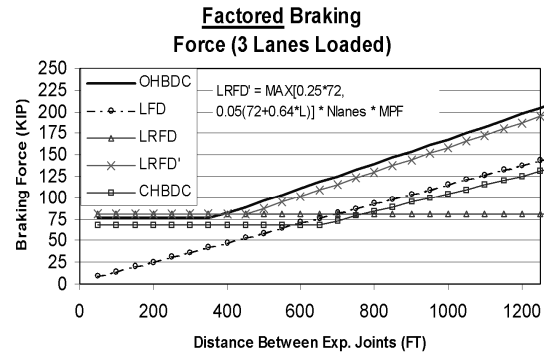

Figure C3.6.4-1 (continued)—Comparison of Braking Force Models

where:

- OHBDC= factored braking force as specified in the 3rd edition of the *Ontario Highway Bridge Design Code*
- LFD = factored braking force as specified in the AASHTO Standard Specifications (Load Factor)
- LRFD = factored braking force as specified in previous versions of the LRFD Specifications (up to 2001 Interim edition)
- LRFD' = factored braking force as specified in Article 3.6.4
- CHBDC= factored braking force as specified in the *Canadian Highway Bridge Design Code*

The sloping portion of the curves represents the braking force that includes a portion of the lane load. This represents the possibility of having multiple lanes of vehicles contributing to the same braking event on a long bridge. Although the probability of such an event is likely to be small, the inclusion of a portion of the lane load gives such an event consideration for bridges with heavy truck traffic and is consistent with other design codes.

Because the LRFD braking force is significantly higher than that required in the Standard Specifications, this issue becomes important in rehabilitation projects designed under previous versions of the design code. In

cases where substructures are found to be inadequate to resist the increased longitudinal forces, consideration should be given to design and detailing strategies which distribute the braking force to additional substructure units during a braking event.

3.6.5—Vehicular Collision Force: *CT*

3.6.5.1—Protection of Structures

Unless the Owner determines that site conditions indicate otherwise, abutments and piers located within a distance of 30.0 ft to the edge of roadway shall be investigated for collision. Collision shall be addressed by either providing structural resistance or by redirecting or absorbing the collision load. The provisions of Article 2.3.2.2.1 shall apply as appropriate.

Where the design choice is to provide structural resistance, the pier or abutment shall be designed for an equivalent static force of 600 kip, which is assumed to act in a direction of zero to 15 degrees with the edge of the pavement in a horizontal plane, at a distance of 5.0 ft above ground.

Where the design choice is to redirect or absorb the collision load, protection shall consist of one of the following:

- An embankment;
- A structurally independent, crashworthy ground-mounted 54.0-in. high barrier, located within 10.0 ft from the component being protected; or
- A 42.0-in. high barrier located at more than 10.0 ft from the component being protected.

Such barrier shall be structurally and geometrically capable of surviving the crash test for Test Level 5, as specified in Section 13.

C3.6.5.1

Where an Owner chooses to make an assessment of site conditions for the purpose of implementing this provision, input from highway or safety engineers and structural engineers should be part of that assessment.

The equivalent static force of 600 kip is based on the information from full-scale crash tests of rigid columns impacted by 80.0-kip tractor trailers at 50 mph. For individual column shafts, the 600-kip load should be considered a point load. Field observations indicate shear failures are the primary mode of failure for individual columns and columns that are 30.0 in. in diameter and smaller are the most vulnerable. For wall piers, the load may be considered to be a point load or may be distributed over an area deemed suitable for the size of the structure and the anticipated impacting vehicle, but not greater than 5.0 ft wide by 2.0 ft high. These dimensions were determined by considering the size of a truck frame.

Requirements for train collision load found in previous editions have been removed. Designers are encouraged to consult the AREMA Manual for Railway Engineering or local railroad company guidelines for train collision requirements.

For the purpose of this Article, a barrier may be considered structurally independent if it does not transmit loads to the bridge.

Full-scale crash tests have shown that some vehicles have a greater tendency to lean over or partially cross over a 42.0-in. high barrier than a 54.0-in. high barrier. This behavior would allow a significant collision of the vehicle with the component being protected if the component is located within a few ft of the barrier. If the component is more than about 10.0 ft behind the barrier, the difference between the two barrier heights is no longer important.

One way to determine whether site conditions qualify for exemption from protection is to evaluate the annual frequency of impact from heavy vehicles. With the approval of the Owner, the annual frequency for a bridge pier to be hit by a heavy vehicle, AF_{HBP} , can be calculated by:

$$AF_{HBP} = 2(ADTT) (P_{HBP})365 \quad (C3.6.5.1-1)$$

where:

ADTT = the number of trucks per day in one direction

P_{HBP} = the annual probability for a bridge pier to be hit by a heavy vehicle

Table C3.6.1.4.2-1 may be used to determine ADTT from available ADT data.

$P_{HBP} = 3.457 \times 10^{-9}$ for undivided roadways in tangent and horizontally curved sections

1.090 $\times 10^{-9}$ for divided roadways in tangent sections
2.184 $\times 10^{-9}$ for divided roadways in horizontally curved sections

Design for vehicular collision force is not required if AF_{HBP} is less than 0.0001 for critical or essential bridges or 0.001 for typical bridges.

The determination of the annual frequency for a bridge pier to be hit by a heavy vehicle, AF_{HBP} , is derived from limited statistical studies performed by the Texas Transportation Institute. Due to limited data, no distinction has been made between tangent sections and horizontally curved sections for undivided roadways. The target values for AF_{HBP} mirror those for vessel collision force found in Article 3.14.5.

Table C3.6.5.1-1 provides typical resulting values for AF_{HBP} .

Table C3.6.5.1-1—Typical Values of AF_{HBP}

		Undivided	Divided Curved	Divided Tangent
		$P_{HBP}=3.457E-09$	$P_{HBP}=2.184E-09$	$P_{HBP}=1.09E-09$
ADT (Both Directions)	ADTT* (One Way)	$AF_{HBP} = 2 \times ADTT \times 365 \times P_{HBP}$		
1000	50	0.0001	0.0001	0.0000
2000	100	0.0003	0.0002	0.0001
3000	150	0.0004	0.0002	0.0001
4000	200	0.0005	0.0003	0.0002
6000	300	0.0008	0.0005	0.0002
8000	400	0.0010	0.0006	0.0003
12000	600	0.0015	0.0010	0.0005
14000	700	0.0018	0.0011	0.0006
16000	800	0.0020	0.0013	0.0006
18000	900	0.0023	0.0014	0.0007
20000	1000	0.0025	0.0016	0.0008
22000	1100	0.0028	0.0018	0.0009
24000	1200	0.0030	0.0019	0.0010
26000	1300	0.0033	0.0021	0.0010
28000	1400	0.0035	0.0022	0.0011

*Assumes ten percent of ADT is truck traffic.

3.6.5.2—Vehicle Collision with Barriers

The provisions of Section 13 shall apply.

3.7—WATER LOADS: *WA*

3.7.1—Static Pressure

Static pressure of water shall be assumed to act perpendicular to the surface that is retaining the water. Pressure shall be calculated as the product of height of water above the point of consideration and the specific weight of water.

Design water levels for various limit states shall be as specified and/or approved by the Owner.

3.7.2—Buoyancy

Buoyancy shall be considered to be an uplift force, taken as the sum of the vertical components of static pressures, as specified in Article 3.7.1, acting on all components below design water level.

3.7.3—Stream Pressure

3.7.3.1—Longitudinal

The pressure of flowing water acting in the longitudinal direction of substructures shall be taken as:

$$p = \frac{C_D V^2}{1,000} \quad (3.7.3.1-1)$$

where:

- p = pressure of flowing water (ksf)
- C_D = drag coefficient for piers as specified in Table 3.7.3.1-1
- V = design velocity of water for the design flood in strength and service limit states and for the check flood in the extreme event limit state (ft/s)

Table 3.7.3.1-1—Drag Coefficient

Type	C_D
Semicircular-nosed pier	0.7
Square-ended pier	1.4
Debris lodged against the pier	1.4
Wedged-nosed pier with nose angle 90 degrees or less	0.8

The longitudinal drag force shall be taken as the product of longitudinal stream pressure and the projected surface exposed thereto.

C3.7.2

For substructures with cavities in which the presence or absence of water cannot be ascertained, the condition producing the least favorable force effect should be chosen.

C3.7.3.1

For the purpose of this Article, the longitudinal direction refers to the major axis of a substructure unit.

The theoretically correct expression for Eq. 3.7.3.1-1 is:

$$p = C_D \frac{w}{2g} V^2 \quad (C3.7.3.1-1)$$

where:

- w = specific weight of water (kcf)
- V = velocity of water (ft/s)
- g = gravitational acceleration constant—32.2 (ft/s²)

As a convenience, Eq. 3.7.3.1-1 recognizes that $w/2g \sim 1/1,000$, but the dimensional consistency is lost in the simplification.

The drag coefficient, C_D , and the lateral drag coefficient, C_L , given in Tables 3.7.3.1-1 and 3.7.3.2-1, were adopted from the Ontario Highway Bridge Design Code (1991). The more favorable drag coefficients measured by some researchers for wedge-type pier nose angles of less than 90 degrees are not given here because such pier noses are more prone to catching debris.

Floating logs, roots, and other debris may accumulate at piers and, by blocking parts of the waterway, increase stream pressure load on the pier. Such accumulation is a

function of the availability of such debris and level of maintenance efforts by which it is removed. It may be accounted for by the judicious increase in both the exposed surface and the velocity of water.

The draft New Zealand Highway Bridge Design Specification contains the following provision, which may be used as guidance in the absence of site-specific criteria:

Where a significant amount of driftwood is carried, water pressure shall also be allowed for on a driftwood raft lodged against the pier. The size of the raft is a matter of judgment, but as a guide, Dimension A in Figure C3.7.3.1-1 should be half the water depth, but not greater than 10.0 ft. Dimension B should be half the sum of adjacent span lengths, but no greater than 45.0 ft. Pressure shall be calculated using Eq. 3.7.3.1-1, with $C_D = 0.5$. (Distances have been changed from SI.)

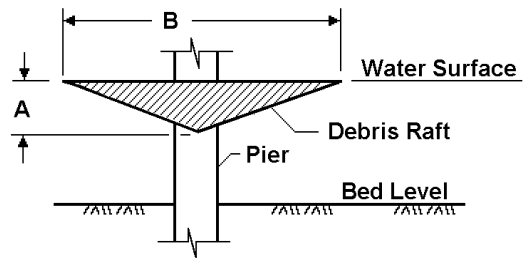

Figure C3.7.3.1-1—Debris Raft for Pier Design

3.7.3.2—Lateral

The lateral, uniformly distributed pressure on a substructure due to water flowing at an angle, θ , to the longitudinal axis of the pier shall be taken as:

$$p = \frac{C_L V^2}{1000} \tag{3.7.3.2-1}$$

where:

- p = lateral pressure (ksf)
- C_L = lateral drag coefficient specified in Table 3.7.3.2-1

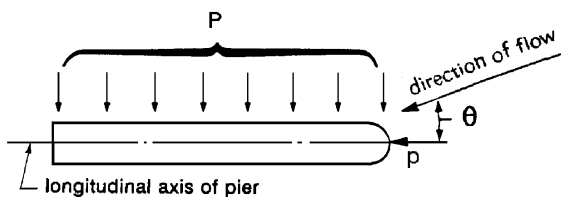

Figure 3.7.3.2-1—Plan View of Pier Showing Stream Flow Pressure

C3.7.3.2

The discussion of Eq. 3.7.3.1-1 also applies to Eq. 3.7.3.2-1.

Table 3.7.3.2-1—Lateral Drag Coefficient

Angle, θ , between direction of flow and longitudinal axis of the pier	C_L
0 degrees	0.0
5 degrees	0.5
10 degrees	0.7
20 degrees	0.9
≥ 30 degrees	1.0

The lateral drag force shall be taken as the product of the lateral stream pressure and the surface exposed thereto.

3.7.4—Wave Load

Wave action on bridge structures shall be considered for exposed structures where the development of significant wave forces may occur.

3.7.5—Change in Foundations Due to Limit State for Scour

The provisions of Article 2.6.4.4 shall apply.

The consequences of changes in foundation conditions resulting from the design flood for scour shall be considered at strength and service limit states. The consequences of changes in foundation conditions due to scour resulting from the check flood for bridge scour and from hurricanes shall be considered at the extreme event limit states.

3.8—WIND LOAD: W_L AND W_S

3.8.1—Horizontal Wind Pressure

3.8.1.1—General

Pressures specified herein shall be assumed to be caused by a base design wind velocity, V_B , of 100 mph.

Wind load shall be assumed to be uniformly distributed on the area exposed to the wind. The exposed area shall be the sum of areas of all components, including floor system, railing, and sound barriers, as seen in elevation taken perpendicular to the assumed wind direction. This direction shall be varied to determine the extreme force effect in the structure or in its components. Areas that do not contribute to the extreme force effect under consideration may be neglected in the analysis.

For bridges or parts of bridges and sound barriers more than 30.0 ft above low ground or water level, the design wind velocity, V_{DZ} , should be adjusted according to:

C3.7.4

Loads due to wave action on bridge structures shall be determined using accepted engineering practice methods. Site-specific conditions should be considered. The latest edition of the *Shore Protection Manual*, published by the Coastal Engineering Research Center, Department of the Army, is recommended for the computation of wave forces.

C3.7.5

Statistically speaking, scour is the most common reason for the failure of highway bridges in the United States.

Provisions concerning the effects of scour are given in Section 2. Scour per se is not a force effect, but by changing the conditions of the substructure it may significantly alter the consequences of force effects acting on structures.

C3.8.1.1

Base design wind velocity varies significantly due to local conditions. For small and/or low structures, wind usually does not govern. For large and/or tall bridges and sound barriers, however, the local conditions should be investigated.

Pressures on windward and leeward sides are to be taken simultaneously in the assumed direction of wind.

Typically, a bridge structure should be examined separately under wind pressures from two or more different directions in order to ascertain those windward, leeward, and side pressures producing the most critical loads on the structure.

Eq. 3.8.1.1-1 is based on boundary layer theory combined with empirical observations and represents the most recent approach to defining wind speeds for various

$$V_{DZ} = 2.5V_0 \left(\frac{V_{30}}{V_B} \right) \ln \left(\frac{Z}{Z_0} \right) \tag{3.8.1.1-1}$$

where:

- V_{DZ} = design wind velocity at design elevation, Z (mph)
- V_{30} = wind velocity at 30.0 ft above low ground or above design water level (mph)
- V_B = base wind velocity of 100 mph at 30.0 ft height, yielding design pressures specified in Articles 3.8.1.2.1 and 3.8.1.2.2
- Z = height of structure at which wind loads are being calculated as measured from low ground, or from water level, > 30.0 ft
- V_0 = friction velocity, a meteorological wind characteristic taken, as specified in Table 3.8.1.1-1, for various upwind surface characteristics (mph)
- Z_0 = friction length of upstream fetch, a meteorological wind characteristic taken as specified in Table 3.8.1.1-1 (ft)

conditions as used in meteorology. In the past, an exponential equation was sometimes used to relate wind speed to heights above 30.0 ft. This formulation was based solely on empirical observations and had no theoretical basis.

$$V_{DZ} = CV_{30} \left(\frac{Z}{30} \right)^\alpha \tag{C3.8.1.1-1}$$

The purpose of the term C and exponent α was to adjust the equation for various upstream surface conditions, similar to the use of Table 3.8.1.1-1. Further information can be found in Liu (1991) and Simiu (1973, 1976).

The following descriptions for the terms “open country,” “suburban,” and “city” in Table 3.8.1.1-1 are paraphrased from ASCE-7-93:

- Open Country—Open terrain with scattered obstructions having heights generally less than 30.0 ft. This category includes flat open country and grasslands.
- Suburban—Urban and suburban areas, wooded areas, or other terrain with numerous closely spaced obstructions having the size of single-family or larger dwellings. Use of this category shall be limited to those areas for which representative terrain prevails in the upwind direction at least 1,500 ft.
- City—Large city centers with at least 50 percent of the buildings having a height in excess of 70.0 ft. Use of this category shall be limited to those areas for which representative terrain prevails in the upwind direction at least one-half mile. Possible channeling effects of increased velocity pressures due to the bridge or structure’s location in the wake of adjacent structures shall be taken into account.

Table 3.8.1.1-1—Values of V_0 and Z_0 for Various Upstream Surface Conditions

Condition	Open Country	Suburban	City
V_0 (mph)	8.20	10.90	12.00
Z_0 (ft)	0.23	3.28	8.20

Except for sound barriers, V_{30} may be established from:

- Fastest-mile-of-wind charts available in ASCE 7-88 for various recurrence intervals,
- Site-specific wind surveys, and
- In the absence of better criterion, the assumption that $V_{30} = V_B = 100$ mph.

For sound barriers, V_{30} shall be taken as specified in Article 15.8.2.

3.8.1.2—Wind Pressure on Structures: *WS**3.8.1.2.1—General*

If justified by local conditions, a different base design wind velocity may be selected for load combinations not involving wind on live load. The direction of the design wind shall be assumed to be horizontal, unless otherwise specified in Article 3.8.3. In the absence of more precise data, design wind pressure, in ksf, may be determined as:

$$P_D = P_B \left(\frac{V_{DZ}}{V_B} \right)^2 = P_B \frac{V_{DZ}^2}{10,000} \quad (3.8.1.2.1-1)$$

$P_B =$ base wind pressure specified in Table 3.8.1.2.1-1 (ksf)

The wind force on the structure shall be calculated by multiplying the design wind pressure, P_D , calculated using Eq. 3.8.1.2.1-1, by the exposed area, including the area of sound barriers, if existing, regardless of the design wind pressure used in designing the sound barriers themselves.

Table 3.8.1.2.1-1—Base Pressures, P_B , Corresponding to $V_B = 100$ mph

Superstructure Component	Windward Load, ksf	Leeward Load, ksf
Trusses, Columns, and Arches	0.050	0.025
Beams	0.050	NA
Large Flat Surfaces	0.040	NA

The total wind loading shall not be taken less than 0.30 klf in the plane of a windward chord and 0.15 klf in the plane of a leeward chord on truss and arch components, and not less than 0.30 klf on beam or girder spans.

3.8.1.2.2—Loads from Superstructures

Except where specified herein, where the wind is not taken as normal to the structure, the base wind pressures, P_B , for various angles of wind direction may be taken as specified in Table 3.8.1.2.2-1 and shall be applied to the centroid of a single plane of exposed area. The skew angle shall be taken as measured from a perpendicular to the longitudinal axis. The wind direction for design shall be that which produces the extreme force effect on the component under investigation. The transverse and longitudinal pressures shall be applied simultaneously.

C3.8.1.2.1

The stagnation pressure associated with a wind velocity of 100 mph is 0.0256 ksf, which is significantly less than the values specified in Table 3.8.1.2.1-1. The difference reflects the effect of gusting combined with some tradition of long-time usage.

The pressures specified in klf or ksf should be chosen to produce the greater net wind load on the structure.

Wind tunnel tests may be used to provide more precise estimates of wind pressures. Such testing should be considered where wind is a major design load.

Due to the lack of information on the wind force on sound barriers, the wind pressure specified in Article 15.8.2 for the design of sound barriers is based on producing similar wind pressures to those used for the design of sound barriers (AASHTO, 1989). Such values of wind pressures proved to produce safe designs in the past.

The term “columns” in Table 3.8.1.2.1-1 refers to columns in superstructures such as spandrel columns in arches.

C3.8.1.2.2

For trusses, columns, and arches, the base wind pressures specified in Table 3.8.1.2.2-1 are the sum of the pressures applied to both the windward and leeward areas.

Table 3.8.1.2.2-1—Base Wind Pressures, P_B , for Various Angles of Attack and $V_B = 100$ mph

Skew Angle of Wind (degrees)	Trusses, Columns and Arches		Girders	
	Lateral Load (ksf)	Longitudinal Load (ksf)	Lateral Load (ksf)	Longitudinal Load (ksf)
0	0.075	0.000	0.050	0.000
15	0.070	0.012	0.044	0.006
30	0.065	0.028	0.041	0.012
45	0.047	0.041	0.033	0.016
60	0.024	0.050	0.017	0.019

For the usual girder and slab bridges having an individual span length of not more than 125 ft and a maximum height of 30.0 ft above low ground or water level the following wind loading may be used:

- 0.05 ksf, transverse
- 0.012 ksf, longitudinal

Both forces shall be applied simultaneously. These forces shall not be used in determining the forces on sound barriers.

Wind pressure on sound barriers should be determined using the provisions of Article 15.8.2.

3.8.1.2.3—Forces Applied Directly to the Substructure

The transverse and longitudinal forces to be applied directly to the substructure shall be calculated from an assumed base wind pressure of 0.040 ksf. For wind directions taken skewed to the substructure, this force shall be resolved into components perpendicular to the end and front elevations of the substructure. The component perpendicular to the end elevation shall act on the exposed substructure area as seen in end elevation, and the component perpendicular to the front elevation shall act on the exposed areas and shall be applied simultaneously with the wind loads from the superstructure.

3.8.1.3—Wind Pressure on Vehicles: WL

When vehicles are present, the design wind pressure shall be applied to both structure and vehicles. Wind pressure on vehicles shall be represented by an interruptible, moving force of 0.10 klf acting normal to, and 6.0 ft above, the roadway and shall be transmitted to the structure.

Except where specified herein, when wind on vehicles is not taken as normal to the structure, the components of normal and parallel force applied to the live load may be taken as specified in Table 3.8.1.3-1 with the skew angle taken as referenced normal to the surface.

C3.8.1.3

Based on practical experience, maximum live loads are not expected to be present on the bridge when the wind velocity exceeds 55 mph. The load factor corresponding to the treatment of wind on structure only in Load Combination Strength III would be $(55/100)^2 (1.4) = 0.42$, which has been rounded to 0.40 in the Strength V Load Combination. This load factor corresponds to 0.3 in Service I.

The 0.10 klf wind load is based on a long row of randomly sequenced passenger cars, commercial vans, and trucks exposed to the 55 mph design wind. This horizontal live load, similar to the design lane load, should be applied only to the tributary areas producing a force effect of the same kind.

Table 3.8.1.3-1—Wind Components on Live Load

Skew Angle (degrees)	Normal Component (klf)	Parallel Component (klf)
0	0.100	0.000
15	0.088	0.012
30	0.082	0.024
45	0.066	0.032
60	0.034	0.038

For the usual girder and slab bridges having an individual span length of not more than 125 ft and a maximum height of 30.0 ft above low ground or water level, the following wind loading may be used:

- 0.10 klf, transverse
- 0.04 klf, longitudinal

Both forces shall be applied simultaneously.

3.8.2—Vertical Wind Pressure

Unless otherwise determined in Article 3.8.3, a vertical upward wind force of 0.020 ksf times the width of the deck, including parapets and sidewalks, shall be considered to be a longitudinal line load. This force shall be applied only for the Strength III and Service IV limit states which do not involve wind on live load, and only when the direction of wind is taken to be perpendicular to the longitudinal axis of the bridge. This lineal force shall be applied at the windward quarter-point of the deck width in conjunction with the horizontal wind loads specified in Article 3.8.1.

3.8.3—Aeroelastic Instability

3.8.3.1—General

Aeroelastic force effects shall be taken into account in the design of bridges and structural components apt to be wind-sensitive. For the purpose of this Article, all bridges with a span to depth ratio, and structural components thereof with a length to width ratio, exceeding 30.0 shall be deemed to be wind-sensitive.

The vibration of cables due to the interaction of wind and rain shall also be considered.

C3.8.2

The intent of this Article is to account for the effect resulting from interruption of the horizontal flow of air by the superstructure. This load is to be applied even to discontinuous bridge decks, such as grid decks. This load may govern where overturning of the bridge is investigated.

C3.8.3.1

Because of the complexity of analyses often necessary for an in-depth evaluation of structural aeroelasticity, this Article is intentionally kept to a simple statement. Many bridges, decks, or individual structural components have been shown to be aeroelastically insensitive if the specified ratios are under 30.0, a somewhat arbitrary value helpful only in identifying likely wind-sensitive cases.

Flexible bridges, such as cable-supported or very long spans of any type, may require special studies based on wind tunnel information. In general, appropriate wind tunnel tests involve simulation of the wind environment local to the bridge site. Details of this are part of the existing wind tunnel state of the art and are beyond the scope of this commentary.

3.8.3.2—Aeroelastic Phenomena

The aeroelastic phenomena of vortex excitation, galloping, flutter, and divergence shall be considered where applicable.

C3.8.3.2

Excitation due to vortex shedding is the escape of wind-induced vortices behind the member, which tend to excite the component at its fundamental natural frequency in harmonic motion. It is important to keep stresses due to vortex-induced oscillations below the “infinite life” fatigue stress. Methods exist for estimating such stress amplitudes, but they are outside the scope of this commentary.

Tubular components can be protected against vortex-induced oscillation by adding bracing, strakes, or tuned mass dampers or by attaching horizontal flat plates parallel to the tube axis above and/or below the central third of their span. Such aerodynamic damper plates should lie about one-third tube diameter above or below the tube to allow free passage of wind. The width of the plates may be the diameter of the tube.

Galloping is a high-amplitude oscillation associated with ice-laden cables or long, flexible members having aerodynamically unsymmetrical cross-sections. Cable-stays, having circular sections, will not gallop unless their circumferences are deformed by ice, dropping water, or accumulated debris.

Flexible bridge decks, as in very long spans and some pedestrian bridges, may be prone to wind-induced flutter, a wind-excited oscillation of destructive amplitudes, or, on some occasions, divergence, an irreversible twist under high wind. Analysis methods, including wind tunnel studies leading to adjustments of the deck form, are available for prevention of both flutter and divergence.

3.8.3.3—Control of Dynamic Responses

Bridges and structural components thereof, including cables, shall be designed to be free of fatigue damage due to vortex-induced or galloping oscillations. Bridges shall be designed to be free of divergence and catastrophic flutter up to 1.2 times the design wind velocity applicable at bridge deck height.

C3.8.3.3

Cables in stayed-girder bridges have been successfully stabilized against excessive dynamic responses by attaching automotive dampers to the bridge at deck level or by cross-tying multiple cable-stays.

3.8.3.4—Wind Tunnel Tests

Representative wind tunnel tests may be used to satisfy the requirements of Articles 3.8.3.2 and 3.8.3.3.

C3.8.3.4

Wind tunnel testing of bridges and other civil engineering structures is a highly developed technology, which may be used to study the wind response characteristics of a structural model or to verify the results of analysis (Simiu, 1976).

3.9—ICE LOADS: *IC*

3.9.1—General

This Article refers only to freshwater ice in rivers and lakes; ice loads in seawater should be determined by suitable specialists using site-specific information.

C3.9.1

Most of the information for ice loads was taken from Montgomery et al. (1984), which provided background for the clauses on ice loads for Canadian

Ice forces on piers shall be determined with regard to site conditions and expected modes of ice action as follows:

- Dynamic pressure due to moving sheets or floes of ice being carried by stream flow, wind, or currents;
- Static pressure due to thermal movements of ice sheets;
- Pressure resulting from hanging dams or jams of ice; and
- Static uplift or vertical load resulting from adhering ice in waters of fluctuating level.

The expected thickness of ice, the direction of its movement, and the height of its action shall be determined by field investigations, review of public records, aerial surveys, or other suitable means.

Standards Association (1988). A useful additional source has been Neill (1981).

It is convenient to classify ice forces on piers as dynamic forces and static forces.

Dynamic forces occur when a moving ice floe strikes a bridge pier. The forces imposed by the ice floe on a pier are dependent on the size of the floe, the strength and thickness of the ice, and the geometry of the pier.

The following types of ice failure have been observed (Montgomery et al., 1984):

- Crushing, where the ice fails by local crushing across the width of a pier. The crushed ice is continually cleared from a zone around the pier as the floe moves past.
- Bending, where a vertical reaction component acts on the ice floe impinging on a pier with an inclined nose. This reaction causes the floe to rise up the pier nose, as flexural cracks form.
- Splitting, where a comparatively small floe strikes a pier and is split into smaller parts by stress cracks propagating from the pier.
- Impact, where a small floe is brought to a halt by impinging on the nose of the pier before it has crushed over the full width of the pier, bent or split.
- Buckling, where compressive forces cause a large floe to fail by buckling in front of the nose of a very wide pier.

For bridge piers of usual proportions on larger bodies of water, crushing and bending failures usually control the magnitude of the design dynamic ice force. On smaller streams, which cannot carry large ice floes, impact failure can be the controlling mode.

In all three cases, it is essential to recognize the effects of resonance between the pier and the ice forces. Montgomery et al. (1980) have shown that for a massive pier with a damping coefficient of 20 percent of critical, the maximum dynamic effect is approximately equal to the greatest force, but for lesser damping values there is a considerable amplification.

Montgomery and Lipsett (1980) measured damping of a massive pier at 19 percent of critical, but it is expected that slender piers and individual piles may have damping values of five percent or less.

In the discussion of impact-type ice failure above, the indication is that the floe is "small." Small is extremely difficult to define and is site-specific. Floes up to 75.0 ft long have been observed to fail by splitting when driven by water velocities of 10.0 ft/s (Haynes, 1996).

Static forces may be caused by the thermal expansion of ice in which a pier is embedded or by irregular growth of the ice field. This has typically been

observed downstream of a dam, or hydroelectric plant or other channel where ice predominantly forms only on one side of the river or pier.

Ice jams can arch between bridge piers. The break-up ice jam is a more or less cohesionless accumulation of ice fragments (Montgomery et al., 1984).

Hanging dams are created when frazil ice passes under the surface layer of ice and accumulates under the surface ice at the bridge site. The frazil ice comes typically from rapids or waterfalls upstream. The hanging dam can cause a backup of water, which exerts pressure on the pier and can cause scour around or under piers as water flows at an increased velocity.

3.9.2—Dynamic Ice Forces on Piers

3.9.2.1—Effective Ice Strength

In the absence of more precise information, the following values may be used for effective ice crushing strength:

- 8.0 ksf, where breakup occurs at melting temperatures and the ice structure is substantially disintegrated;
- 16.0 ksf, where breakup occurs at melting temperatures and the ice structure is somewhat disintegrated;
- 24.0 ksf, where breakup or major ice movement occurs at melting temperatures, but the ice moves in large pieces and is internally sound; and
- 32.0 ksf, where breakup or major ice movement occurs when the ice temperature, averaged over its depth, is measurably below the melting point.

C3.9.2.1

It should be noted that the effective ice strengths given herein are for the purpose of entering into a formula to arrive at forces on piers. Different formulas might require different effective ice strengths to arrive at the same result.

As a guide, the 8.0 ksf strength is appropriate for piers where long experience indicates that ice forces are minimal, but some allowance is required for ice effects; the 32.0 ksf strength is considered to be a reasonable upper limit based on the observed history of bridges that have survived ice conditions (Neill, 1981). Effective ice strengths of up to 57.6 ksf have been used in the design of some bridges in Alaska (Haynes, 1996).

The effective ice strength depends mostly on the temperature and grain size of the ice (Montgomery et al., 1984). For example, laboratory measured compressive strengths at 32°F vary from about 60.0 ksf for grain sizes of 0.04 in. to 27.0 ksf for grain sizes of 0.2 in., and at 23°F ice strengths are approximately double the values given. Thus, the effective ice strengths given herein are not necessarily representative of laboratory tests or actual ice strengths, and, in fact, are on the order of one-half of observed values (Neill, 1981).

The compressive strength of the ice depends upon temperature, but the tensile strength is not sensitive to temperature. Because much ice failure is the result of splitting or tensile failure in bending, and because grain sizes, cracks, and other imperfections vary in the field, only crude approximations of ice strengths can be made. Thus, temperature is not a consideration for setting effective ice strengths in these Specifications.

Some of the most severe ice runs in the United States occur during a rapid January thaw, when the air temperature is about 50°F, but the average ice temperature can still be below 32°F because of an insulating snow cover (Haynes, 1996).

3.9.2.2—Crushing and Flexing

The horizontal force, F , resulting from the pressure of moving ice shall be taken as:

- If $\frac{w}{t} \leq 6.0$, then:

F = lesser of either F_c or, when ice failure by flexure is considered applicable as described herein, F_b , and

- If $\frac{w}{t} > 6.0$, then:

$$F = F_c$$

in which:

$$F_c = C_a p t w \quad (3.9.2.2-1)$$

$$F_b = C_n p t^2 \quad (3.9.2.2-2)$$

$$C_a = (5 t / w + 1)^{0.5} \quad (3.9.2.2-3)$$

$$C_n = \frac{0.5}{\tan(\alpha - 15)} \quad (3.9.2.2-4)$$

where:

- t = thickness of ice (ft)
- α = inclination of the nose to the vertical (degrees)
- p = effective ice crushing strength as specified in Article 3.9.2.1 (ksf)
- w = pier width at level of ice action (ft)
- F_c = horizontal ice force caused by ice floes that fail by crushing over the full width of the pier (kip)
- F_b = horizontal ice force caused by ice floes that fail by flexure as they ride up the inclined pier nose (kip)
- C_a = coefficient accounting for the effect of the pier width/ice thickness ratio where the floe fails by crushing
- C_n = coefficient accounting for the inclination of the pier nose with respect to a vertical

where $\alpha \leq 15$ degrees, ice failure by flexure shall not be considered to be a possible ice failure mode for the purpose of calculating the horizontal force, F , in which case F shall be taken as F_c .

C3.9.2.2

The expression of F_c is based on field measurements of forces on two bridge piers in Alberta (Lipsett and Gerard, 1980). See also Huiskamp (1983), with a C_a proposed by Afanas'ev et al. (1971), and verified by Neill (1976).

The expression for F_b is taken from Lipsett and Gerard (1980).

$w/t = 6.0$ is a rough estimate of the upper limit of w/t at which ice that has failed by bending will be washed around the pier.

It is assumed that the force on the pier is governed by the crushing or bending strength of the ice, and thus there is not a term in Eqs. 3.9.2.2-1 or 3.9.2.2-2 relating to velocity of the ice. The interaction between an ice floe and a pier depends on the size and strength of the floe and how squarely it strikes the pier. It has been reported that an ice floe 200 ft in size will usually fail by crushing if it hits a pier squarely. If a floe 100 ft in size does not hit the pier squarely, it will usually impact the pier and rotate around the pier and pass downstream with only little local crushing.

Although no account is taken of the shape of the nose of the pier, laboratory tests at the U.S. Army Corps of Engineers' Cold Regions Research and Engineering Laboratory (CRREL) have shown the bullet-shaped pier nose can reduce ice forces the most compared to other types of geometry. Pointed angular noses, as shown in Figure C3.9.2.4.1-1, have been found to cause lateral vibrations of the pier without reducing the streamwise force. CRREL has measured lateral or torsional vibrations on the pointed nose Yukon River Bridge piers. The long-term ramifications of these vibrations are not known at this time (Haynes, 1996).

Ice thickness is the greatest unknown in the determination of ice forces on piers. Equations can be used for estimating ice thickness. The design should be based on the extreme, not average, ice thickness. The elevation on the pier where the design force shall be applied is important for calculating the overturning moments. Because ice stage increases during an ice run, relying on local knowledge of the maximum stage is vital to proper design (Haynes, 1995). For the purpose of design, the preferred method to establish the thickness of ice, t , is to base it on measurements of maximum thicknesses, taken over a period of several years, at the potential bridge sites.

Where observations over a long period of time are not available, an empirical method based on Neill (1981) is suggested as follows:

$$t = 0.083 \alpha \sqrt{S_f} \quad (C3.9.2.2-1)$$

where:

- α = coefficient for local conditions, normally less than 1.0

- S_f = freezing index, being the algebraic sum, $\Sigma(32 - T)$, summed from the date of freeze-up to the date of interest, in degree days
- T = mean daily air temperature (degrees F)

Assuming that temperature records are available, the maximum recorded value of S_f can be determined.

One possible method of determining α is by simple calibration in which, through the course of a single winter, the ice thickness can be measured at various times and plotted against $\sqrt{S_f}$.

As a guide, Neill (1981) indicates the following values for α :

windy lakes without snow	0.8
average lake with snow	0.5–0.7
average river with snow.....	0.4–0.5
sheltered small river with snow	0.2–0.4

Due to its good insulating characteristics, snow has a significant effect on ice growth. Williams (1963) has shown that a snow cover greater than 6.0 in. in thickness has the effect of reducing α by as much as 50 percent.

Neill does not define “average,” and it has been noted by Gerard and Stanely (1992) that deep snow can produce snow-ice, thus offsetting the benefits of snow insulation.

Large lakes take longer to cool down, which leads to a later freeze-up date. This results in fewer degree-days of freezing and, hence, smaller ice thicknesses.

The remaining decision is to establish the appropriate elevation of the ice force to be applied to the pier. The elevation required is that at break-up, not at the mean winter level. Neill (1981) suggests several methods of determining ice elevations, but the most common method in general use is probably to rely on local knowledge and examination of the river banks to determine the extent of damage by ice, such as the marking or removal of trees.

3.9.2.3—Small Streams

On small streams not conducive to the formation of large ice floes, consideration may be given to reducing the forces F_b and F_c , determined in accordance with Article 3.9.2.2, but under no circumstances shall the forces be reduced by more than 50 percent.

C3.9.2.3

CAN/CSA-S6-88 has an expression for ice forces in small streams, for which a theory is given by Montgomery et al. (1984). It is considered insufficiently verified to be included herein.

On small streams, with a width of less than 300 ft at the mean water level, dynamic ice forces, as determined in Article 3.9.2.2, may be reduced in accordance with Table C3.9.2.3-1. Another important factor that determines the ice floe size are the type of features in the river upstream of the site. Islands, dams, and bridge piers can break ice into small floes.

where:

- A = plan area of the largest ice floe in (ft²)
- r = radius of pier nose (ft)

Table C3.9.2.3-1—Reduction Factor K_1 for Small Streams

A/r^2	Reduction Factor, K_1
1000	1.0
500	0.9
200	0.7
100	0.6
50	0.5

The rationale for the reduction factor, K_1 , is that the bridge may be struck only by small ice floes with insufficient momentum to cause failure of the floe.

3.9.2.4—Combination of Longitudinal and Transverse Forces

3.9.2.4.1—Piers Parallel to Flow

The force F , determined as specified in Articles 3.9.2.2 and 3.9.2.3, shall be taken to act along the longitudinal axis of the pier if the ice movement has only one direction and the pier is approximately aligned with that direction. In this case, two design cases shall be investigated as follows:

- A longitudinal force equal to F shall be combined with a transverse force of $0.15F$, or
- A longitudinal force of $0.5F$ shall be combined with a transverse force of F_t .

The transverse force, F_t , shall be taken as:

$$F_t = \frac{F}{2 \tan(\beta/2 + \theta_f)} \quad (3.9.2.4.1-1)$$

where:

- β = nose angle in a horizontal plane for a round nose taken as 100 (degrees)
- θ_f = friction angle between ice and pier nose (degrees)

Both the longitudinal and transverse forces shall be assumed to act at the pier nose.

3.9.2.4.2—Piers Skewed to Flow

Where the longitudinal axis of a pier is not parallel to the principal direction of ice action, or where the direction of ice action may shift, the total force on the pier shall be determined on the basis of the projected pier width and resolved into components. Under such conditions, forces transverse to the longitudinal axis of the pier shall be taken to be at least 20 percent of the total force.

C3.9.2.4.1

It would be unrealistic to expect the ice force to be exactly parallel to the pier, so a minimum lateral component of 15 percent of the longitudinal force is specified.

The expression for F_t comes from Montgomery et al. (1984), and is explained in Figure C3.9.2.4.1-1 taken from the same source.

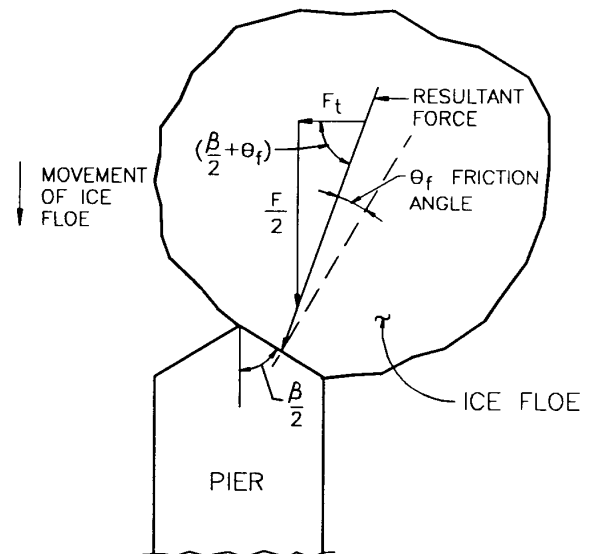

Figure C3.9.2.4.1-1—Transverse Ice Force Where a Floe Fails over a Portion of a Pier

C3.9.2.4.2

The provisions for piers skewed to flow are taken from CAN/CSA-S6-88 (1988).

3.9.2.5—Slender and Flexible Piers

Slender and flexible piers shall not be used in regions where ice forces are significant, unless advice on ice/structure interaction has been obtained from an ice specialist. This provision also applies to slender and flexible components of piers, including piles that come into contact with water-borne ice.

3.9.3—Static Ice Loads on Piers

Ice pressures on piers frozen into ice sheets shall be investigated where the ice sheets are subject to significant thermal movements relative to the pier where the growth of shore ice is on one side only or in other situations that may produce substantial unbalanced forces on the pier.

3.9.4—Hanging Dams and Ice Jams

The frazil accumulation in a hanging dam may be taken to exert a pressure of 0.2 to 2.0 ksf as it moves by the pier. An ice jam may be taken to exert a pressure of 0.02 to 0.20 ksf.

3.9.5—Vertical Forces Due to Ice Adhesion

The vertical force, in kips, on a bridge pier due to rapid water level fluctuation shall be taken as:

For a circular pier:

$$F_v = 80.0t^2 \left(0.35 + \frac{0.03R}{t^{0.75}} \right) \quad (3.9.5-1)$$

For an oblong pier:

$$F_v = 0.2t^{1.25}L + 80.0t^2 \left(0.35 + \frac{0.03R}{t^{0.75}} \right) \quad (3.9.5-2)$$

where:

t = ice thickness (ft)

C3.9.2.5

It has been shown by Montgomery et al. (1980) and others that flexible piers and pier components may experience considerable amplification of the ice forces as a result of resonant ice/structure interaction at low levels of structural damping. In this case, the provisions of Article 3.9.5 may be inadequate for vertical forces on piers.

C3.9.3

Little guidance is available for predicting static ice loads on piers. Under normal circumstances, the effects of static ice forces on piers may be strain-limited, but expert advice should be sought if there is reason for concern. Static ice forces due to thermal expansion of ice are discussed in Haynes (1995). Ice force can be reduced by several mitigating factors that usually apply. For example, ice does not act simultaneously over the full length of the pier. Thermal stresses relax in time and prevent high stresses over the full ice thickness. A snow cover on the ice insulates the ice and reduces the thermal stresses, and ice usually acts simultaneously on both sides of the pier surrounded by the ice so that the resultant force is considerably less than the larger directional force, i.e., force on one side of the pier. Article C3.9.1 contains additional discussion.

C3.9.4

The theory behind the ice pressures given for hanging dams can be found in Montgomery et al. (1984). The wide spread of pressures quoted reflects both the variability of the ice and the lack of firm information on the subject.

C3.9.5

Eq. 3.9.5-1 was derived by considering the failure of a semi-infinite, wedge-shaped ice sheet on an elastic foundation under vertical load applied at its apex. For a single ice wedge, the maximum vertical force, P , can be evaluated from the expression (Nevel, 1972).

$$P = \frac{\tan\left(\frac{\delta}{2}\right)\sigma_T t^2}{3} \left[1.05 + 2\left(\frac{a}{\ell}\right) + 0.5\left(\frac{a}{\ell}\right)^3 \right] \quad (C3.9.5-1)$$

in which:

$$\ell = \left(\frac{Et^3}{12\gamma} \right)^{0.25} = 21.0t^{0.75} \quad (C3.9.5-2)$$

where:

R	=	radius of circular pier (ft); or radius of half circles at ends of an oblong pier (ft); or radius of a circle that circumscribes each end of an oblong pier of which the ends are not circular in plan at water level (ft)	σ_T	=	tensile strength of ice (ksf)
L	=	perimeter of pier, excluding half circles at ends of oblong pier (ft)	t	=	maximum thickness of ice (ft)
			δ	=	angle of the truncated wedge (degrees)
			a	=	truncated distance, which is assumed to be equal to the radius of a circular pier (ft)
			ℓ	=	characteristic length calculated from the expression (ft)
			E	=	Young's modulus for ice (ksf)
			γ	=	unit weight of water (kcf)

To obtain Eq. 3.9.5-1, the vertical force is summed for four wedges, each with a truncated angle of 90 degrees. It is assumed that the tensile strength of ice is 0.84 times an effective crushing strength of 23 ksf and that the ratio of the truncated distance to the characteristic length, a/ℓ , is less than 0.6.

Eq. 3.9.5-2 is the sum of two expressions:

- Eq. 3.9.5-1, which accounts for the vertical ice forces acting on the half circles at the ends of an oblong pier, and
- An expression that calculates the vertical ice forces on the straight walls of the pier.

The expression for calculating the vertical ice forces on the long straight walls of the pier was derived by considering a semi-infinite, rectangular ice sheet on an elastic foundation under a uniformly distributed edge load. The force required to fail the ice sheet, F , can be expressed as $F = 0.236 \sigma_T t^2 / \ell$ (Montgomery et al., 1984).

Eqs. 3.9.5-1 and 3.9.5-2 are based on the conservative assumption that ice adheres around the full perimeter of the pier cross-section. They neglect creep and are, therefore, conservative for water level fluctuations occurring over more than a few minutes. However, they are also based on the nonconservative assumption that failure occurs on the formation of the first crack.

Some issues surrounding ice forces have been reported in Zabilansky (1996).

3.9.6—Ice Accretion and Snow Loads on Superstructures

Generally snow loads, other than those caused by an avalanche, need not be considered. However, Owners in areas where unique accumulations of snow and/or ice are possible should specify appropriate loads for that condition.

Loads due to icing of the superstructure by freezing rain shall be specified if local conditions so warrant.

C3.9.6

The following discussion of snow loads is taken from Ritter (1990).

Snow loads should be considered where a bridge is located in an area of potentially heavy snowfall. This can occur at high elevations in mountainous areas with large seasonal accumulations. Snow loads are normally negligible in areas of the United States that are below 2,000 ft elevation and east of longitude 105°W, or below 1,000 ft elevation and west of longitude 105°W. In other areas of the country, snow loads as large as 0.7 ksf may be encountered in mountainous locations.

The effects of snow are assumed to be offset by an accompanying decrease in vehicle live load. This assumption is valid for most structures, but is not realistic in areas where snowfall is significant. When

prolonged winter closure of a road makes snow removal impossible, the magnitude of snow loads may exceed those from vehicular live loads. Loads also may be notable where plowed snow is stockpiled or otherwise allowed to accumulate. The applicability and magnitude of snow loads are left to the Designer's judgment.

Snow loads vary from year to year and depend on the depth and density of snowpack. The depth used for design should be based on a mean recurrence interval or the maximum recorded depth. Density is based on the degree of compaction. The lightest accumulation is produced by fresh snow falling at cold temperatures. Density increases when the snowpack is subjected to freeze-thaw cycles or rain. Probable densities for several snowpack conditions are indicated in Table C3.9.6-1, ASCE (1980).

Table C3.9.6-1—Snow Density

Condition of Snowpack	Probable Density (kcf)
Freshly Fallen	0.006
Accumulated	0.019
Compacted	0.031
Rain or Snow	0.031

Estimated snow load can be determined from historical records or other reliable data. General information on ground snow loads is available from the National Weather Service, from state and local agencies, and ASCE (1988). Snow loads in mountain areas are subject to extreme variations. The extent of these loads should be determined on the basis of local experience or records, instead of on generalized information.

The effect of snow loads on a bridge structure is influenced by the pattern of snow accumulation. Windblown snow drifts may produce unbalanced loads considerably greater than those produced from uniformly distributed loads. Drifting is influenced by the terrain, structure shape, and other features that cause changes in the general wind flow. Bridge components, such as railings, can serve to contain drifting snow and cause large accumulations to develop.

3.10—EARTHQUAKE EFFECTS: *EQ*

3.10.1—General

Bridges shall be designed to have a low probability of collapse but may suffer significant damage and disruption to service when subject to earthquake ground motions that have a seven percent probability of exceedance in 75 yr. Partial or complete replacement may be required. Higher levels of performance may be used with the authorization of the Bridge Owner.

Earthquake loads shall be taken to be horizontal force effects determined in accordance with the

C3.10.1

The design earthquake motions and forces specified in these provisions are based on a low probability of their being exceeded during the normal life expectancy of a bridge. Bridges that are designed and detailed in accordance with these provisions may suffer damage, but should have low probability of collapse due to seismically induced ground shaking.

The principles used for the development of these Specifications are:

provisions of Article 4.7.4 on the basis of the elastic response coefficient, C_{sm} , specified in Article 3.10.4, and the equivalent weight of the superstructure, and adjusted by the response modification factor, R , specified in Article 3.10.7.1.

The provisions herein shall apply to bridges of conventional construction. The Owner shall specify and/or approve appropriate provisions for nonconventional construction. Unless otherwise specified by the Owner, these provisions need not be applied to completely buried structures.

Seismic effects for box culverts and buried structures need not be considered, except where they cross active faults.

The potential for soil liquefaction and slope movements shall be considered.

- Small to moderate earthquakes should be resisted within the elastic range of the structural components without significant damage;
- Realistic seismic ground motion intensities and forces should be used in the design procedures; and
- Exposure to shaking from large earthquakes should not cause collapse of all or part of the bridge. Where possible, damage that does occur should be readily detectable and accessible for inspection and repair.

Bridge Owners may choose to mandate higher levels of performance for special bridges.

Earthquake loads are given by the product of the elastic seismic response coefficient C_{sm} and the equivalent weight of the superstructure. The equivalent weight is a function of the actual weight and bridge configuration and is automatically included in both the single-mode and multimode methods of analysis specified in Article 4.7.4. Design and detailing provisions for bridges to minimize their susceptibility to damage from earthquakes are contained in Sections 3, 4, 5, 6, 7, 10, and 11. A flow chart summarizing these provisions is presented in Appendix A3.

Conventional bridges include those with slab, beam, box girder, or truss superstructures, and single- or multiple-column piers, wall-type piers, or pile-bent substructures. In addition, conventional bridges are founded on shallow or piled footings, or shafts. Substructures for conventional bridges are also listed in Table 3.10.7.1-1. Nonconventional bridges include bridges with cable-stayed/cable-suspended superstructures, bridges with truss towers or hollow piers for substructures, and arch bridges.

These Specifications are considered to be force-based wherein a bridge is designed to have adequate strength (capacity) to resist earthquake forces (demands). In recent years, there has been a trend away from force-based procedures to those that are displacement-based, wherein a bridge is designed to have adequate displacement capacity to accommodate earthquake demands. Displacement-based procedures are believed to more reliably identify the limit states that cause damage leading to collapse, and in some cases produce more efficient designs against collapse. It is recommended that the displacement capacity of bridges designed in accordance with these Specifications, be checked using a displacement-based procedure, particularly those bridges in high seismic zones. The *AASHTO Guide Specifications for LRFD Seismic Design* (AASHTO, 2009), are displacement-based.

3.10.2—Seismic Hazard

The seismic hazard at a bridge site shall be characterized by the acceleration response spectrum for the site and the site factors for the relevant site class.

The acceleration spectrum shall be determined using either the General Procedure specified in Article 3.10.2.1 or the Site Specific Procedure specified in Article 3.10.2.2.

A Site-Specific Procedure shall be used if any one of the following conditions exist:

- The site is located within 6 mi. of an active fault,
- The site is classified as Site Class F (Article 3.10.3.1),
- Long-duration earthquakes are expected in the region,
- The importance of the bridge is such that a lower probability of exceedance (and therefore a longer return period) should be considered.

If time histories of ground acceleration are used to characterize the seismic hazard for the site, they shall be determined in accordance with Article 4.7.4.3.4b.

3.10.2.1—General Procedure

The General Procedure shall use the peak ground acceleration coefficient (PGA) and the short- and long-period spectral acceleration coefficients (S_S and S_1 respectively) to calculate the spectrum as specified in Article 3.10.4. Values of PGA , S_S and S_1 shall be determined from either Figures 3.10.2.1-1 to 3.10.2.1-21 as appropriate, or from state ground motion maps approved by the Owner.

Linear interpolation shall be used for sites located between contour lines or between a contour line and a local maximum or minimum.

The effect of site class on the seismic hazard shall be as specified in Article 3.10.3.

C3.10.2.1

Values for the coefficients PGA , S_S and S_1 are expressed in percent in Figures 3.10.2.1-1 to 3.10.2.1-21. Numerical values are obtained by dividing contour values by 100. Local maxima and minima are given inside the highest and lowest contour for a particular region.

The above coefficients are based on a uniform risk model of seismic hazard. The probability that a coefficient will not be exceeded at a given location during a 75-yr period is estimated to be about 93 percent, i.e., a seven percent probability of exceedance. The use of a 75-yr interval to characterize this probability is an arbitrary convenience and does not imply that all bridges are thought to have a useful life of 75 yr.

It can be shown that an event with the above probability of exceedance has a return period of about 1,000 yr and is called the design earthquake. Larger earthquakes than that implied by the above set of coefficients have a finite probability of occurrence throughout the United States.

Values for the ground coefficient (PGA) and the spectral coefficients (S_S and S_1) are also available on the *USGS 2007 Seismic Parameters CD*, which is included with this book. Coefficients are given by the longitude and latitude of the bridge site, or by the zip code for the site.

An error has been identified in the “Spectral Response Accelerations S_{DS} and S_{DI} ” results produced by the CD-ROM software. Specifically, the A_s value is erroneously calculated as $A_s = F_a PGA$. Although the corrected value for A_s is presented in the tabulated design spectrum table, designers should be aware of this error until the problem is corrected. The software error will likely have negligible effects on bridge analysis results because:

- F_{pga} is approximately equal to F_a ,
- A_s is properly calculated and displayed in the tabulated design spectra, and
- Bridges have fundamental periods greater than the effected period range ($T_m < T_o$).

In lieu of using the national ground motion maps in Figures 3.10.2.1-1 to 3.10.2.1-21, values for the coefficients PGA , S_S and S_1 may be derived from approved state ground motion maps. To be acceptable, the development of state maps should conform to the following:

- The definition of design ground motions should be the same as described in Articles 3.10.1 and 3.10.2.
- Ground motion maps should be based on a detailed analysis demonstrated to lead to a quantification of ground motion, at a regional scale, that is as accurate or more so, as is achieved in the national maps. The analysis should include: characterization of seismic sources and ground motion that incorporates current scientific knowledge; incorporation of uncertainty in seismic source models, ground motion models, and parameter values used in the analysis; and detailed documentation of map development.

Detailed peer review should be undertaken as deemed appropriate by the Owner. The peer review process should include one or more individuals from the U.S. Geological Survey who participated in the development of the national maps.

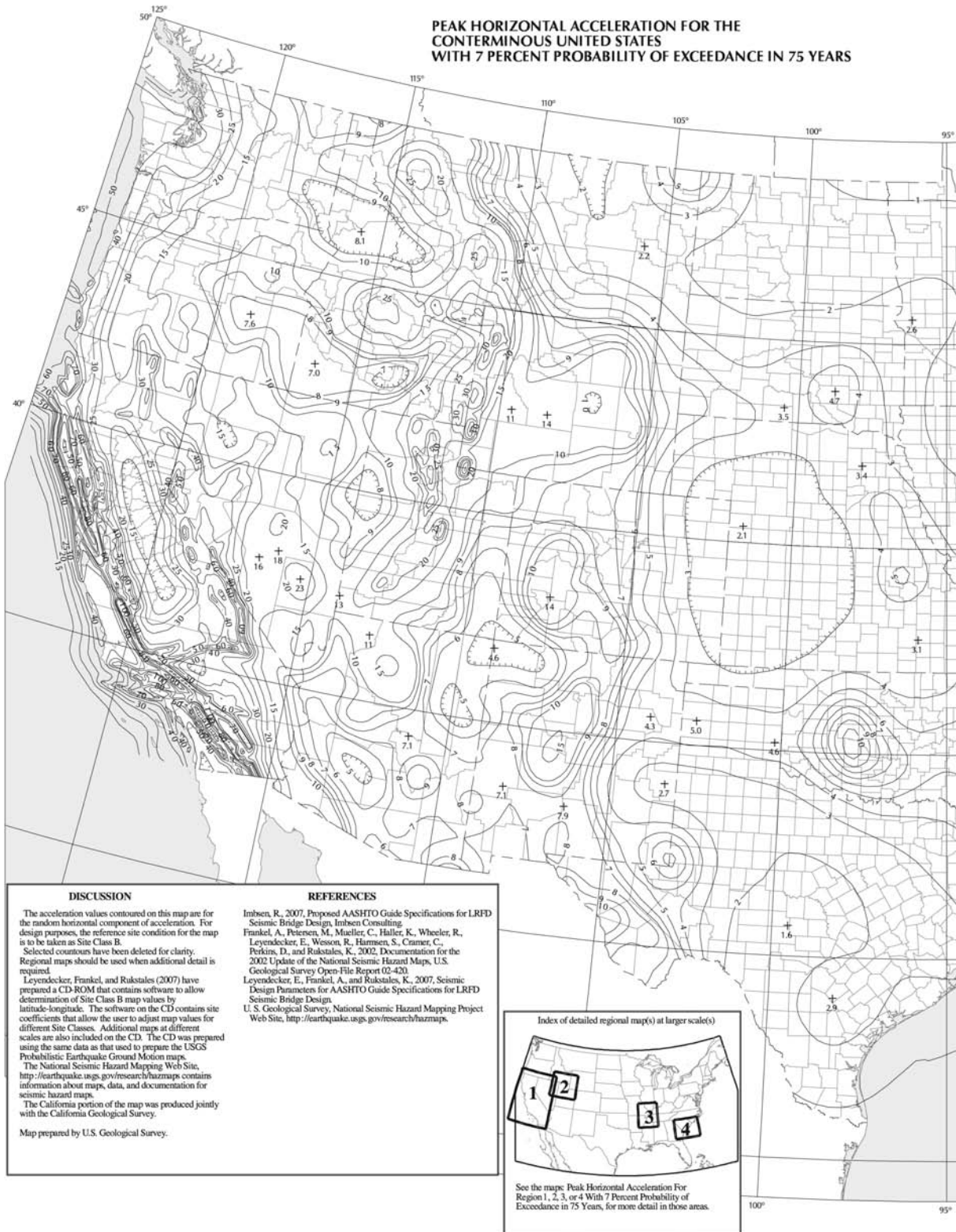

Figure 3.10.2.1-1—Horizontal Peak Ground Acceleration Coefficient for the Conterminous United States (*PGA*) with Seven Percent Probability of Exceedance in 75 yr (Approx. 1000-yr Return Period)

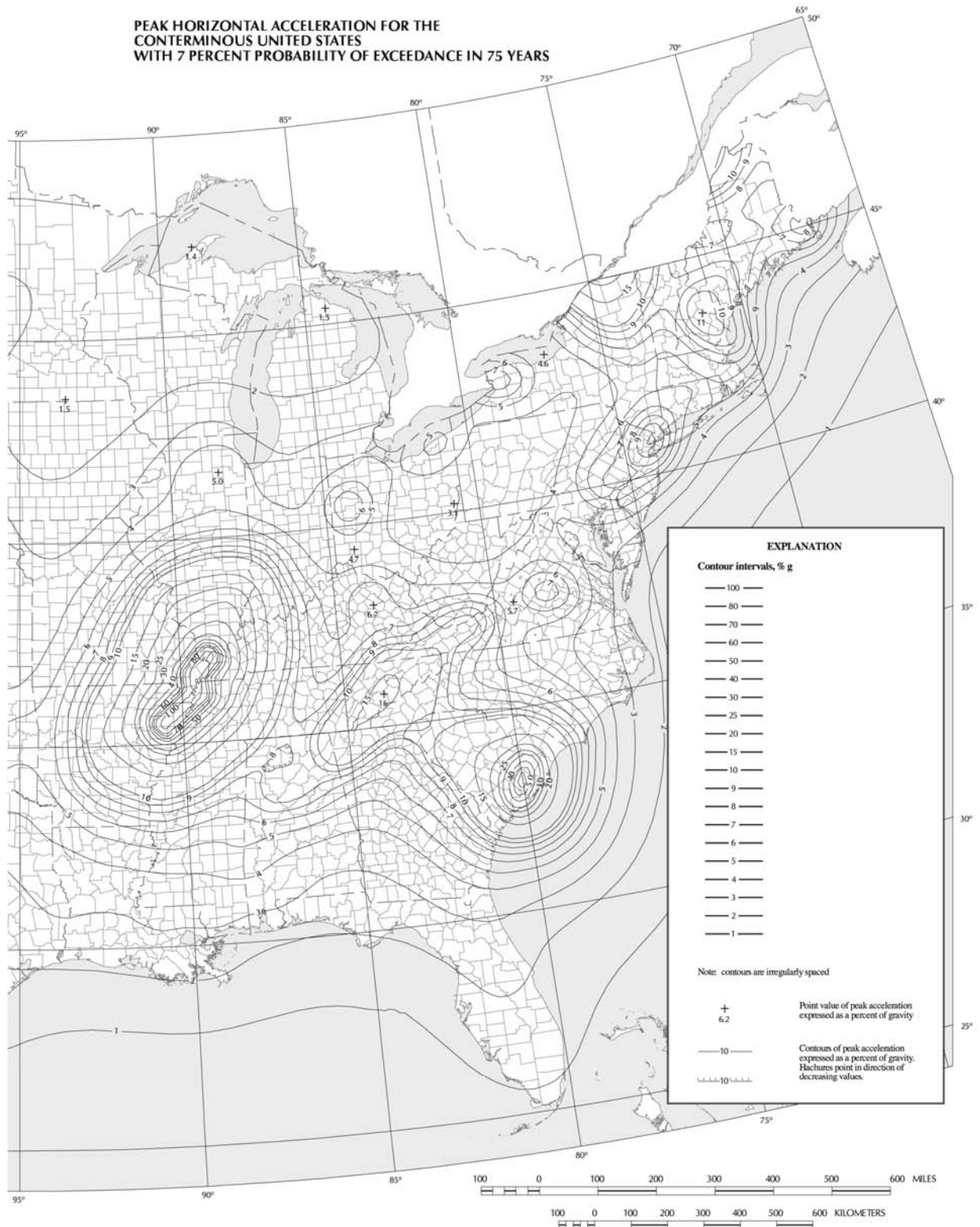

Figure 3.10.2.1-1 (continued)—Horizontal Peak Ground Acceleration Coefficient for the Conterminous United States (PGA) with Seven Percent Probability of Exceedance in 75 yr (Approx. 1000-yr Return Period)

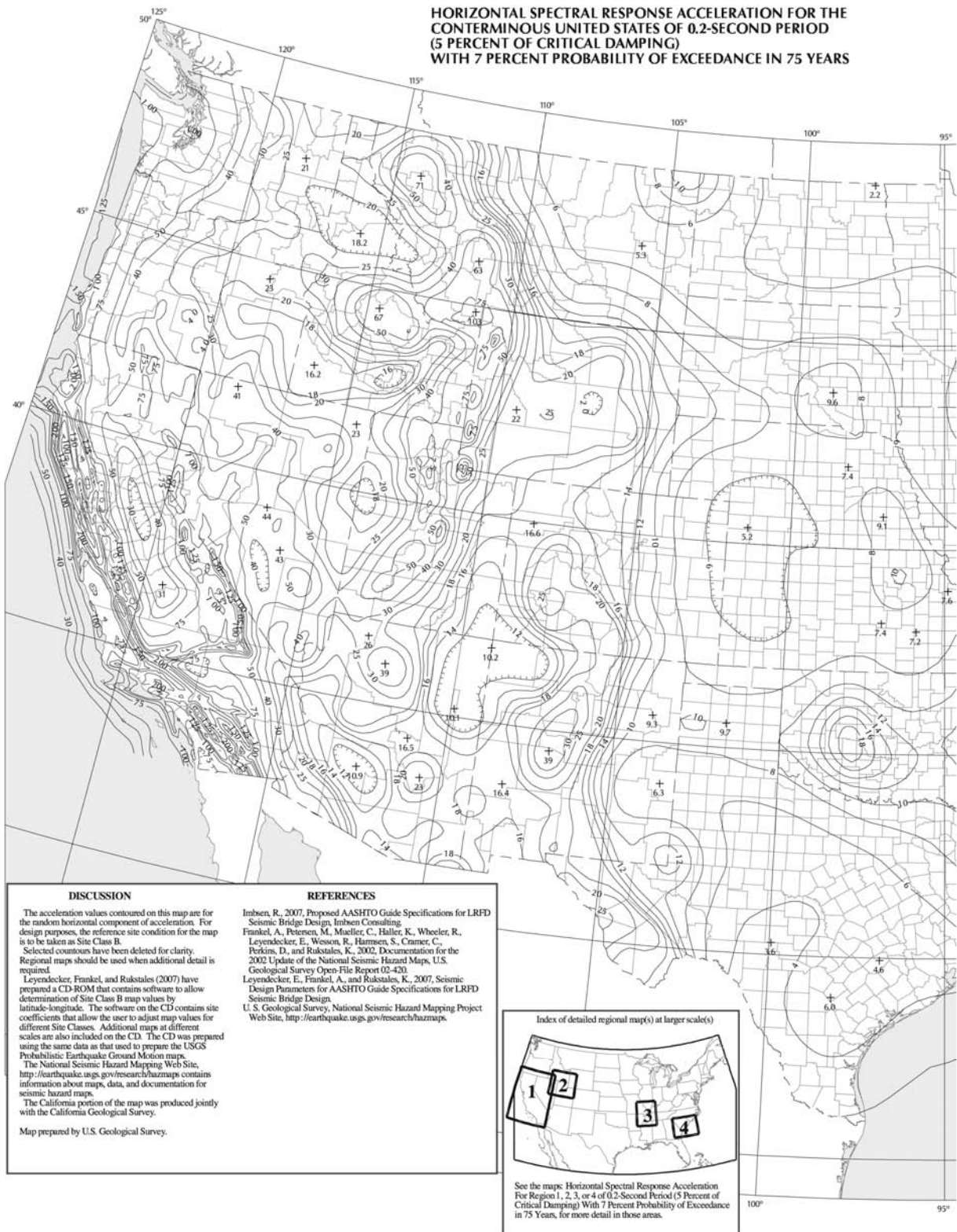

Figure 3.10.2.1-2—Horizontal Response Spectral Acceleration Coefficient for the Conterminous United States at Period of 0.2 s (S_S) with Seven Percent Probability of Exceedance in 75 yr (Approx. 1000-yr Return Period) and Five Percent Critical Damping

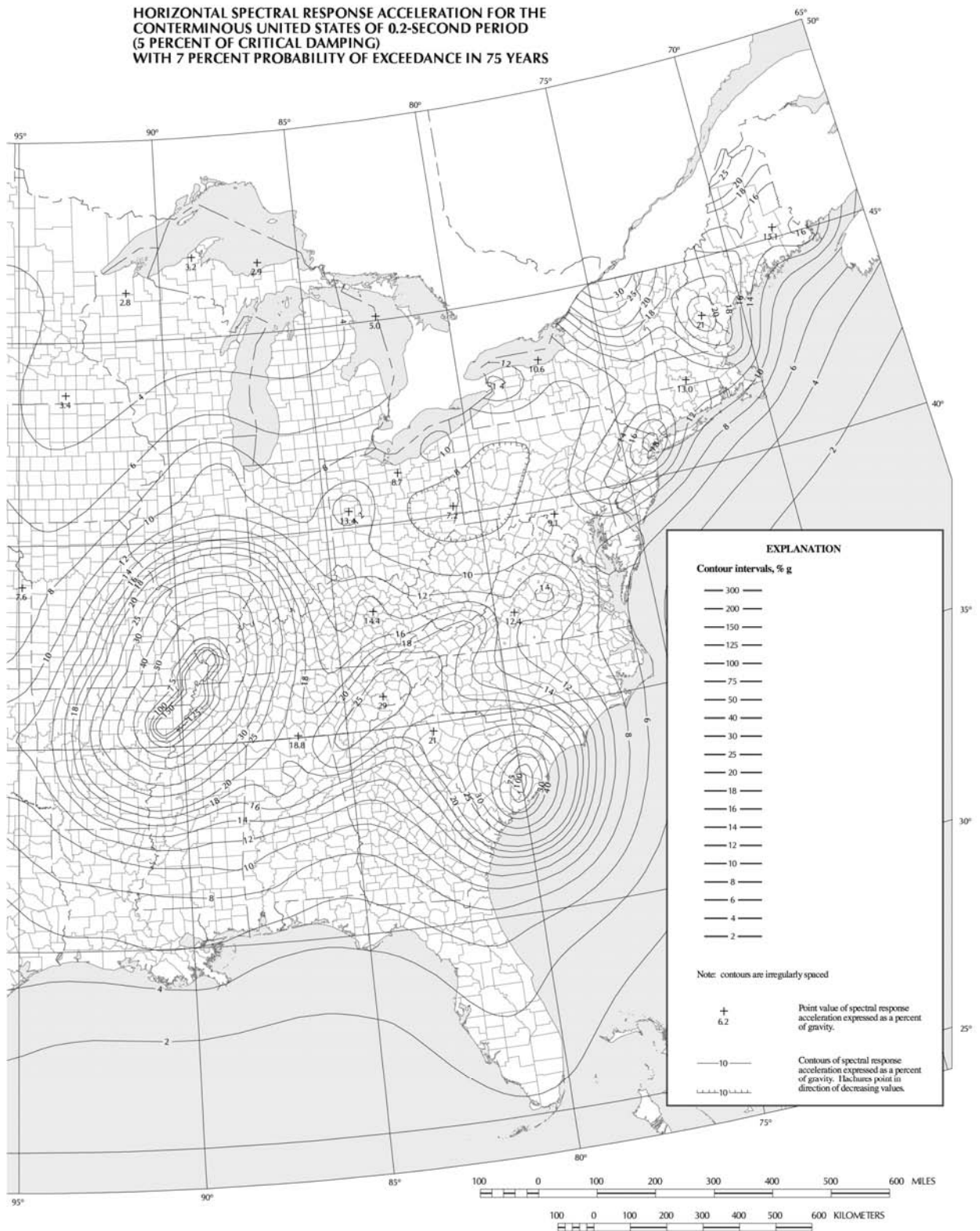

Figure 3.10.2.1-2 (continued)—Horizontal Response Spectral Acceleration Coefficient for the Conterminous United States at Period of 0.2 s (S_S) with Seven Percent Probability of Exceedance in 75 yr (Approx. 1000-yr Return Period) and Five Percent Critical Damping

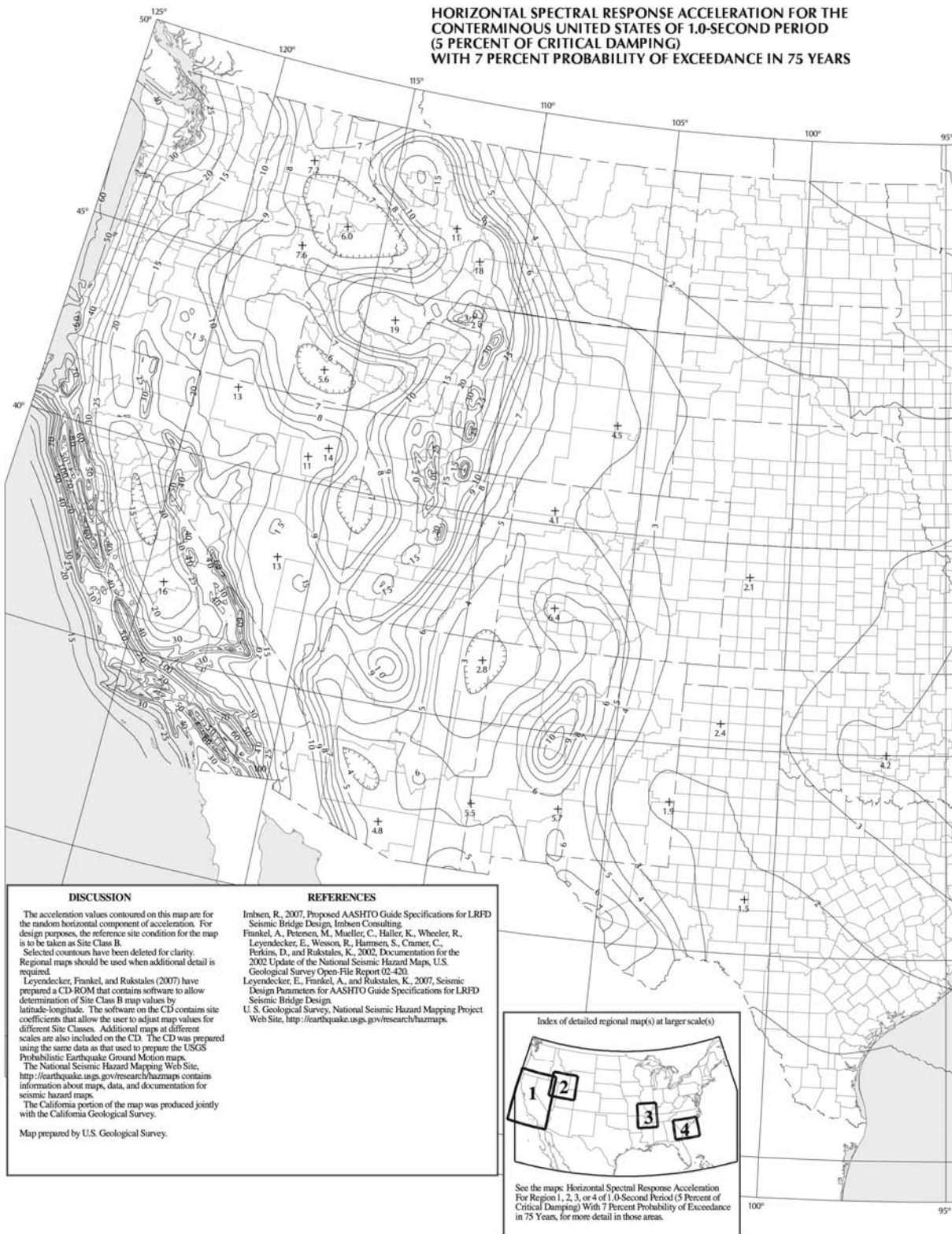

Figure 3.10.2.1-3—Horizontal Response Spectral Acceleration Coefficient for the Conterminous United States at Period of 1.0 s (S_1) with Seven Percent Probability of Exceedance in 75 yr (Approx. 1000-yr Return Period) and Five Percent Critical Damping

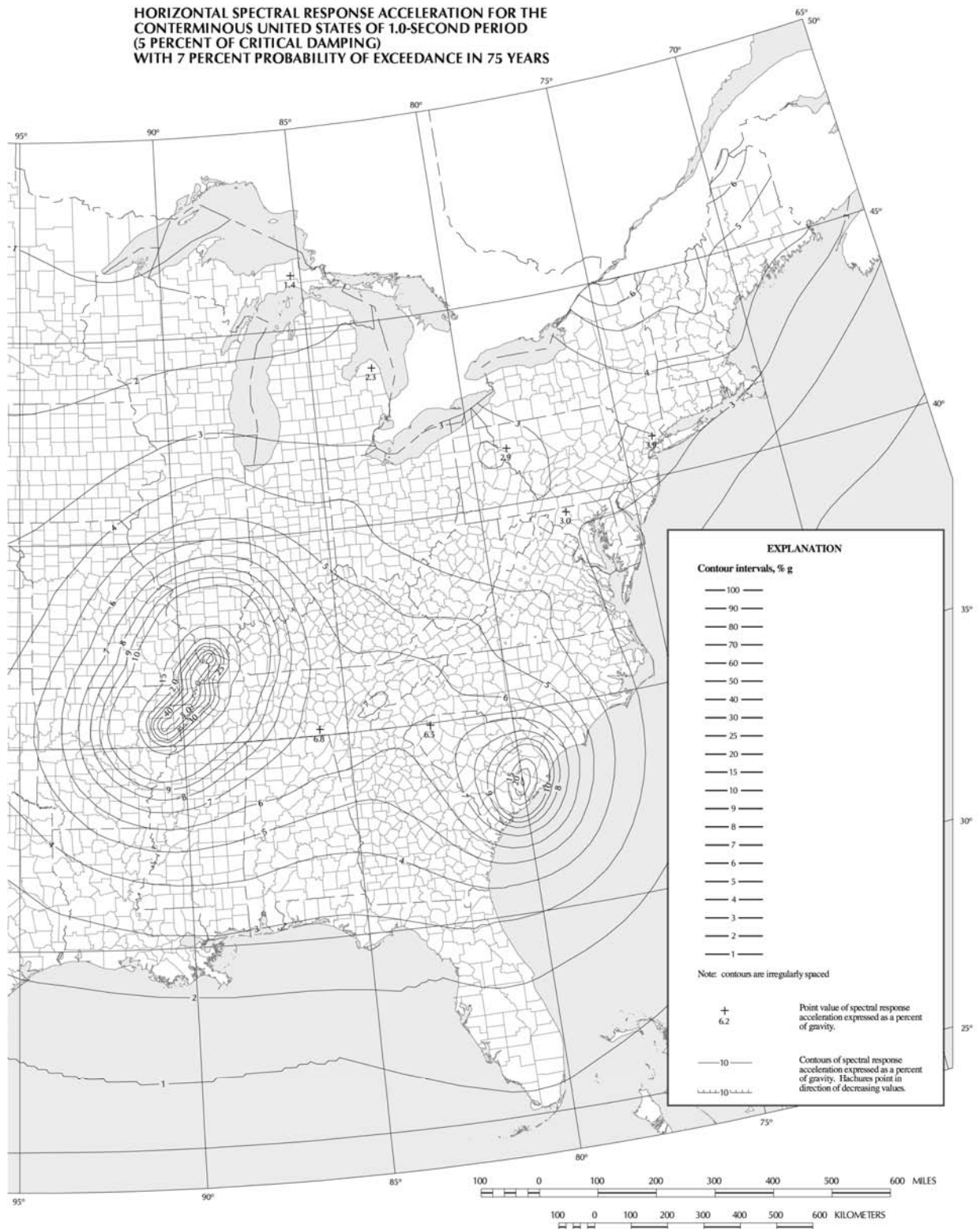

Figure 3.10.2.1-3 (continued)—Horizontal Response Spectral Acceleration Coefficient for the Conterminous United States at Period of 1.0 s (S_1) with Seven Percent Probability of Exceedance in 75 yr (Approx. 1000-yr Return Period) and Five Percent Critical Damping

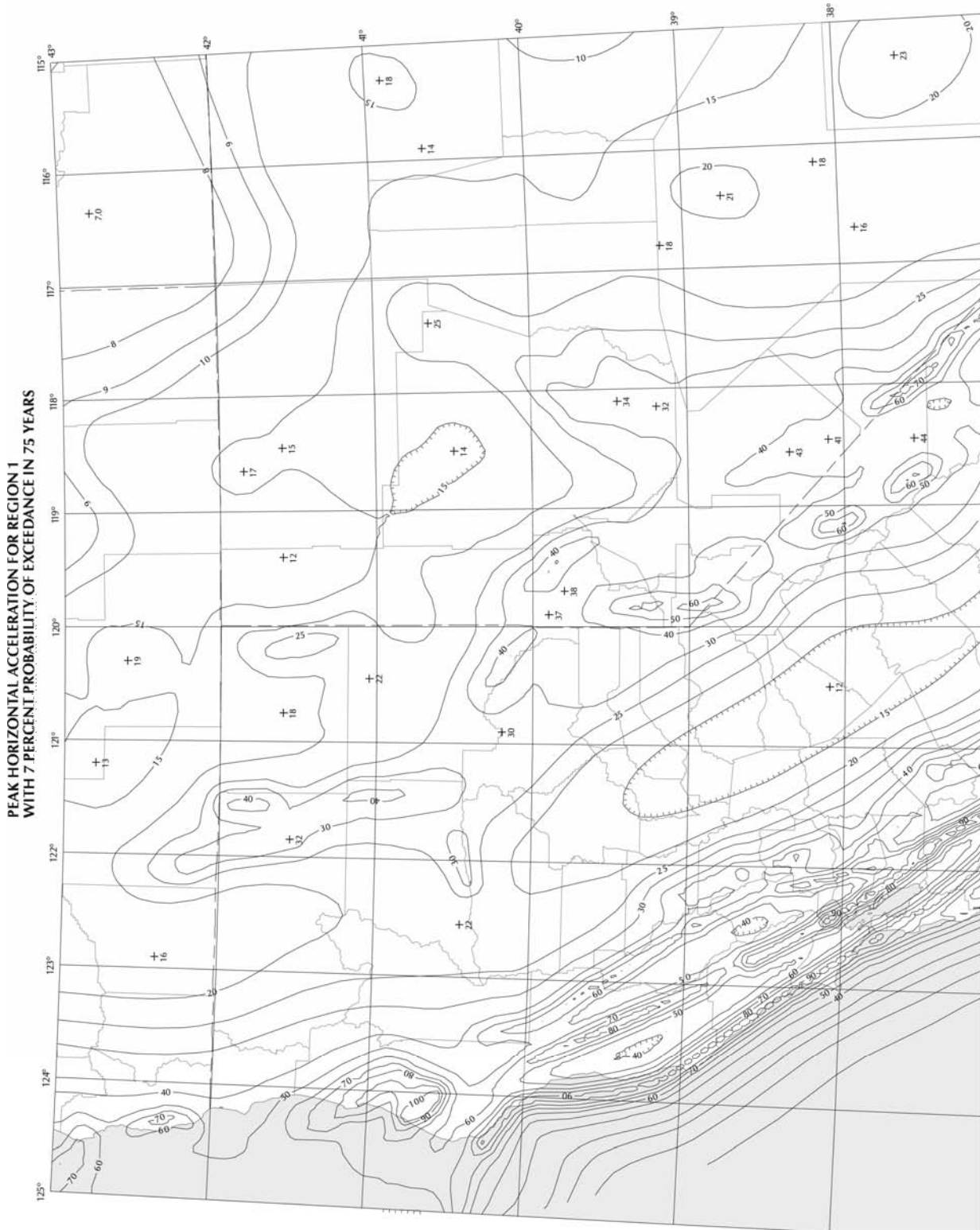

Figure 3.10.2.1-4—Horizontal Peak Ground Acceleration Coefficient for Region 1 (PGA) with Seven Percent Probability of Exceedance in 75 yr (Approx. 1000-yr Return Period)

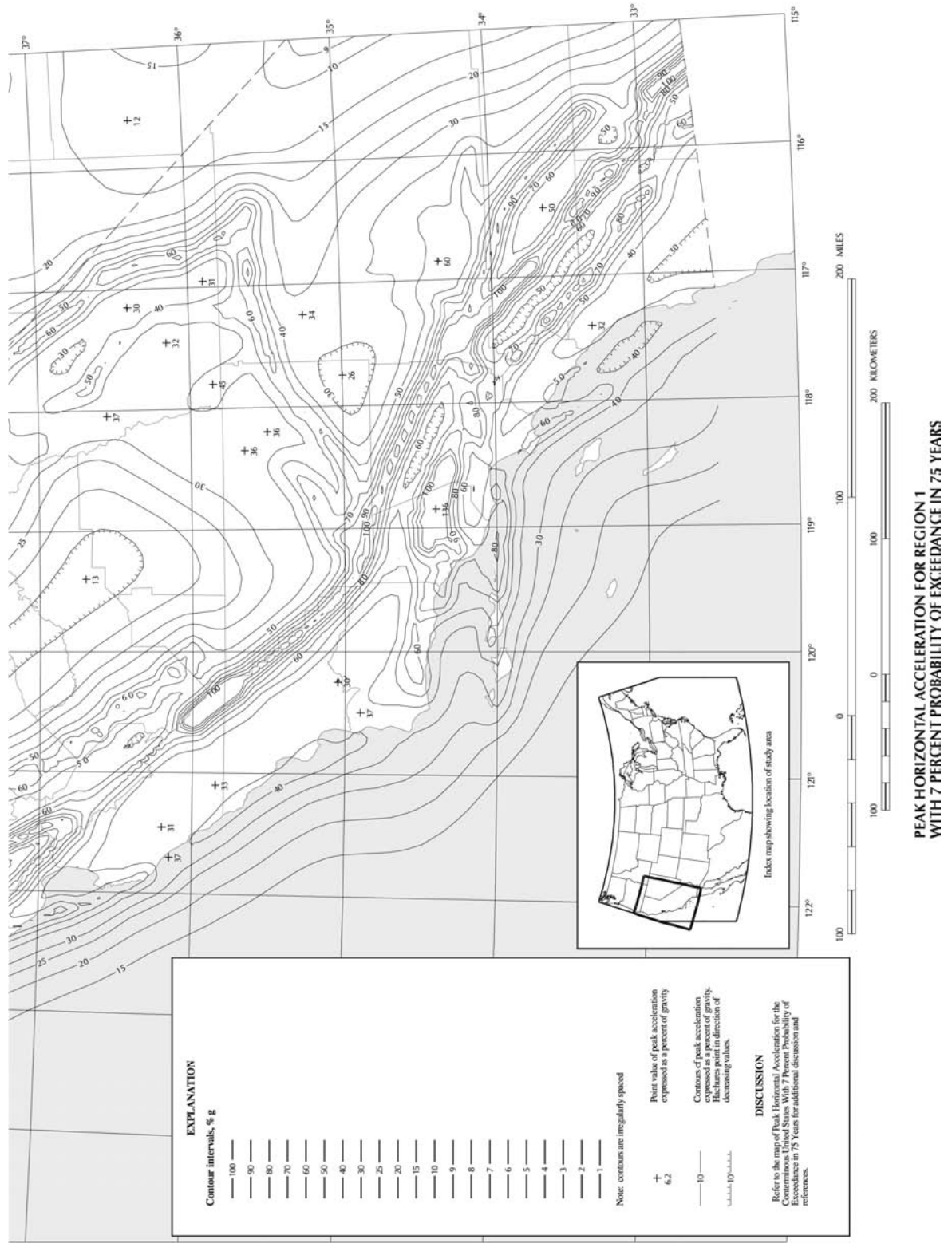

Figure 3.10.2.1-4 (continued)—Horizontal Peak Ground Acceleration Coefficient for Region 1 (PGA) with Seven Percent Probability of Exceedance in 75 yr (Approx. 1000-yr Return Period)

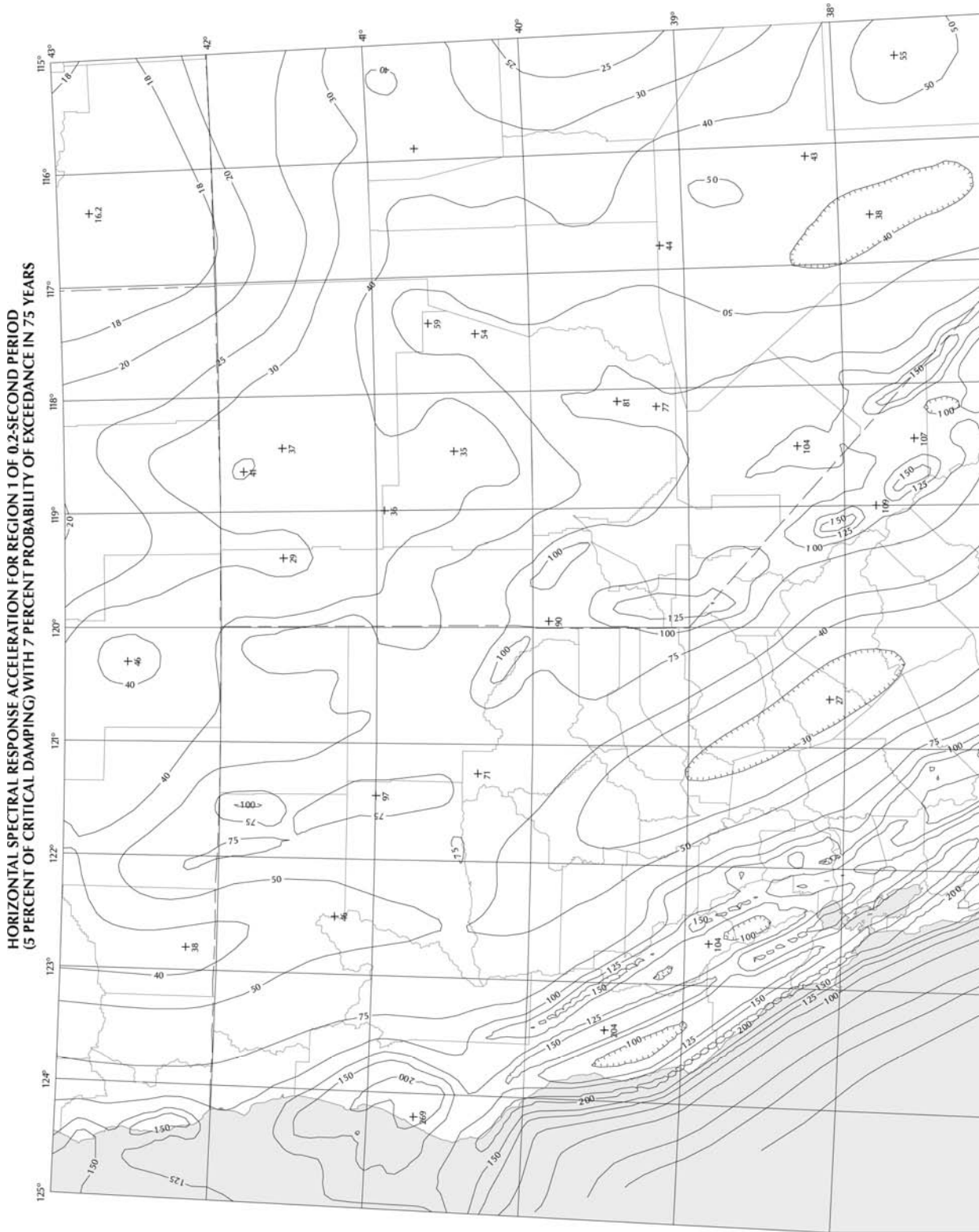

Figure 3.10.2.1-5—Horizontal Response Spectral Acceleration Coefficient for Region 1 at Period of 0.2 s (S_5) with Seven Percent Probability of Exceedance in 75 yr (Approx. 1000-yr Return Period) and Five Percent Critical Damping



HORIZONTAL SPECTRAL RESPONSE ACCELERATION FOR REGION 1 OF 0.2-SECOND PERIOD (5 PERCENT OF CRITICAL DAMPING) WITH 7 PERCENT PROBABILITY OF EXCEEDANCE IN 75 YEARS

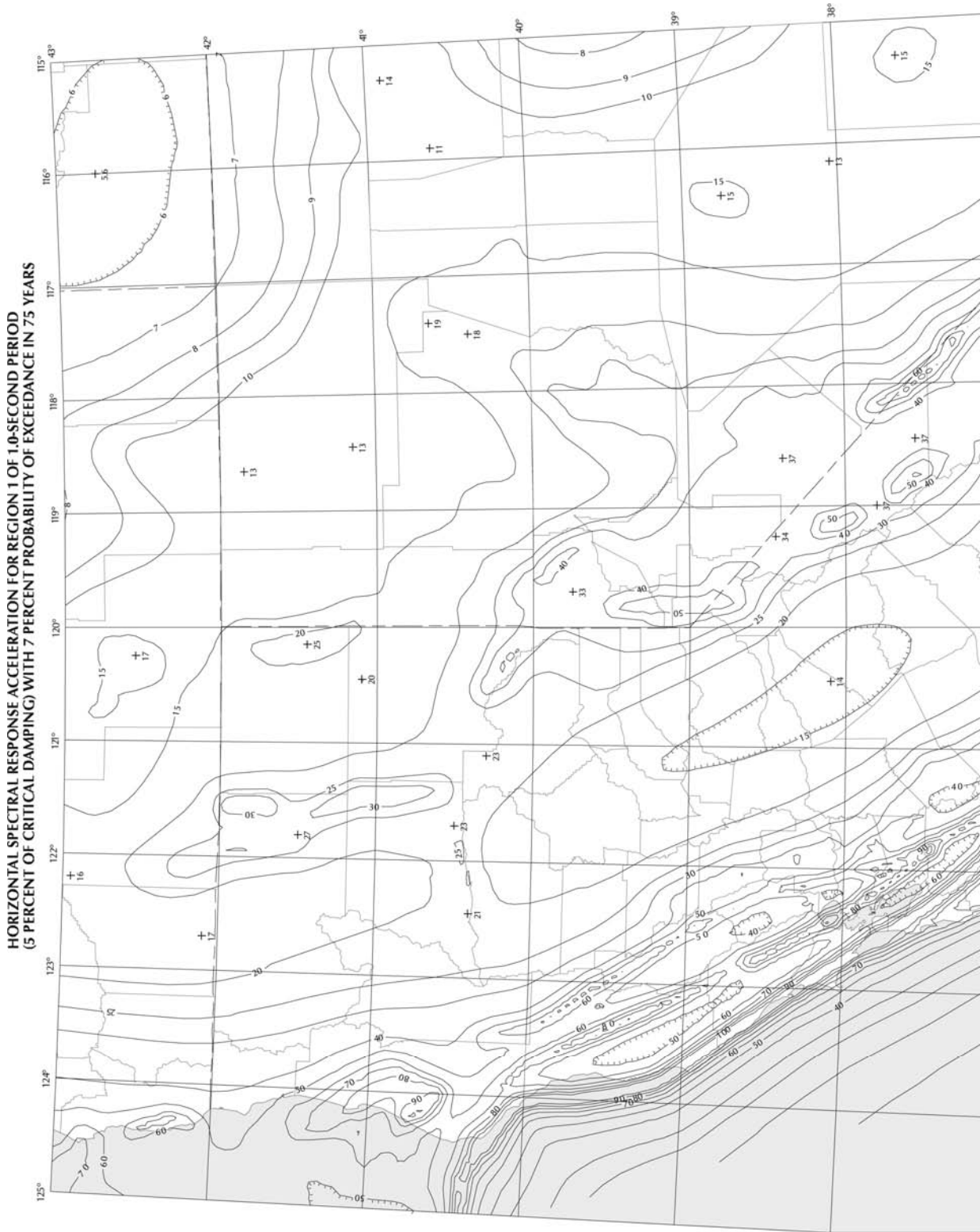
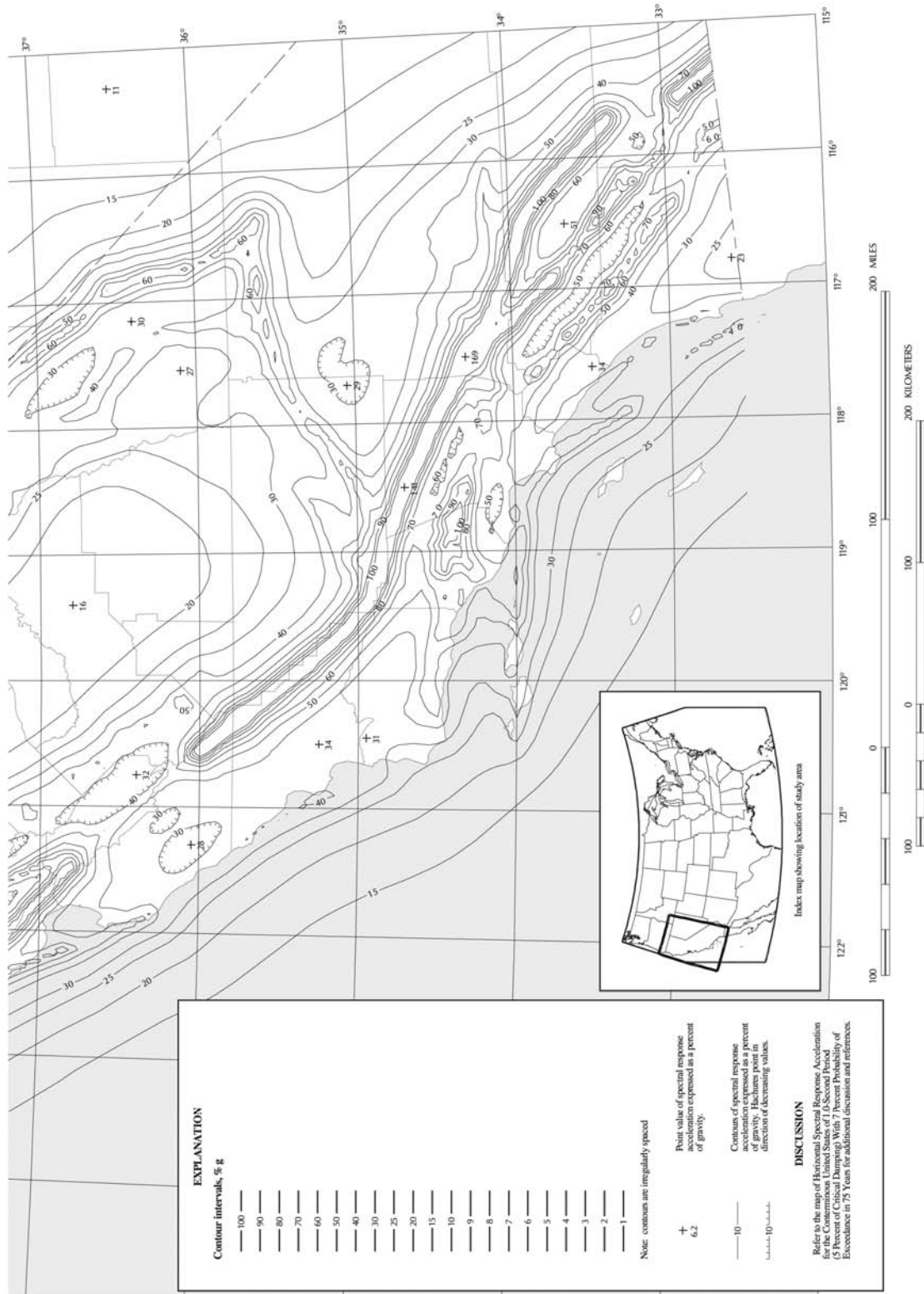

Figure 3.10.2.1-6—Horizontal Response Spectral Acceleration Coefficient for Region 1 at Period of 1.0 s (S_1) with Seven Percent Probability of Exceedance in 75 yr (Approx. 1000-yr Return Period) and Five Percent Critical Damping



HORIZONTAL SPECTRAL RESPONSE ACCELERATION FOR REGION 1 OF 1.0-SECOND PERIOD (5 PERCENT OF CRITICAL DAMPING) WITH 7 PERCENT PROBABILITY OF EXCEEDANCE IN 75 YEARS

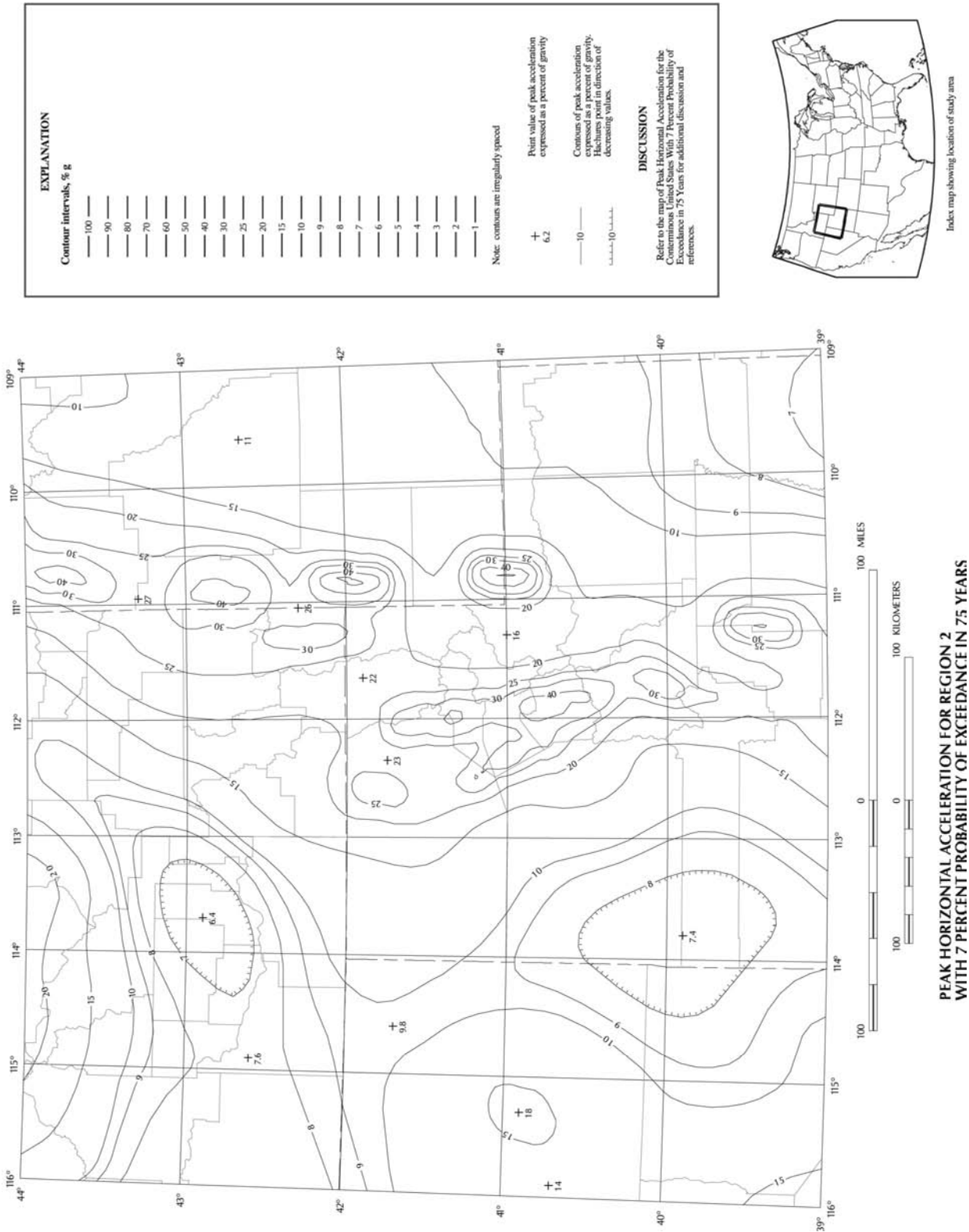

Figure 3.10.2.1-7—Horizontal Peak Ground Acceleration Coefficient for Region 2 (PGA) with Seven Percent Probability of Exceedance in 75 yr (Approx. 1000-yr Return Period)

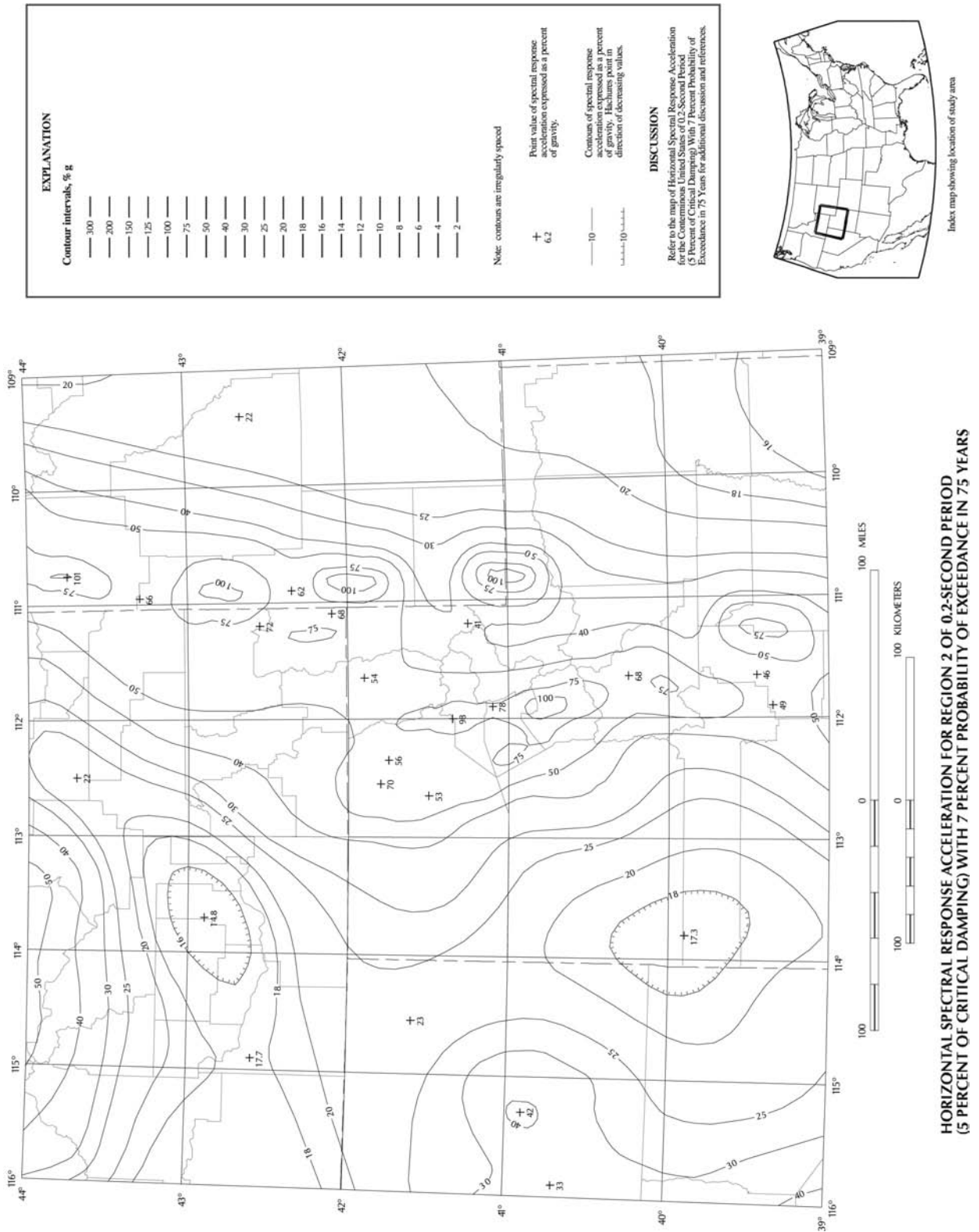

Figure 3.10.2.1-8—Horizontal Response Spectral Acceleration Coefficient for Region 2 at Period of 0.2 s (S_S) with Seven Percent Probability of Exceedance in 75 yr (Approx. 1000-yr Return Period) and Five Percent Critical Damping

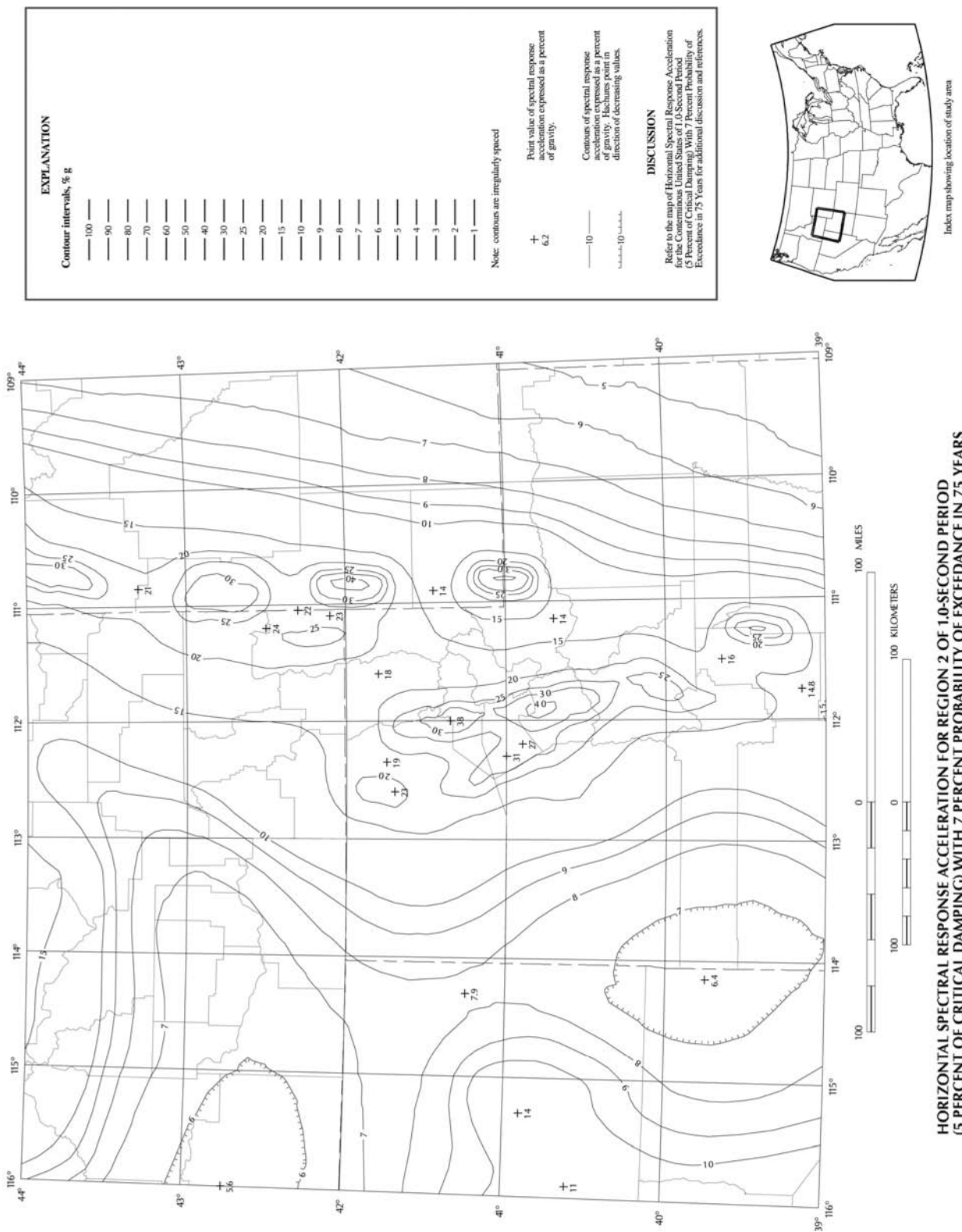

Figure 3.10.2.1-9—Horizontal Response Spectral Acceleration Coefficient for Region 2 at Period of 1.0 s (S_1) with Seven Percent Probability of Exceedance in 75 yr (Approx. 1000-yr Return Period) and Five Percent Critical Damping

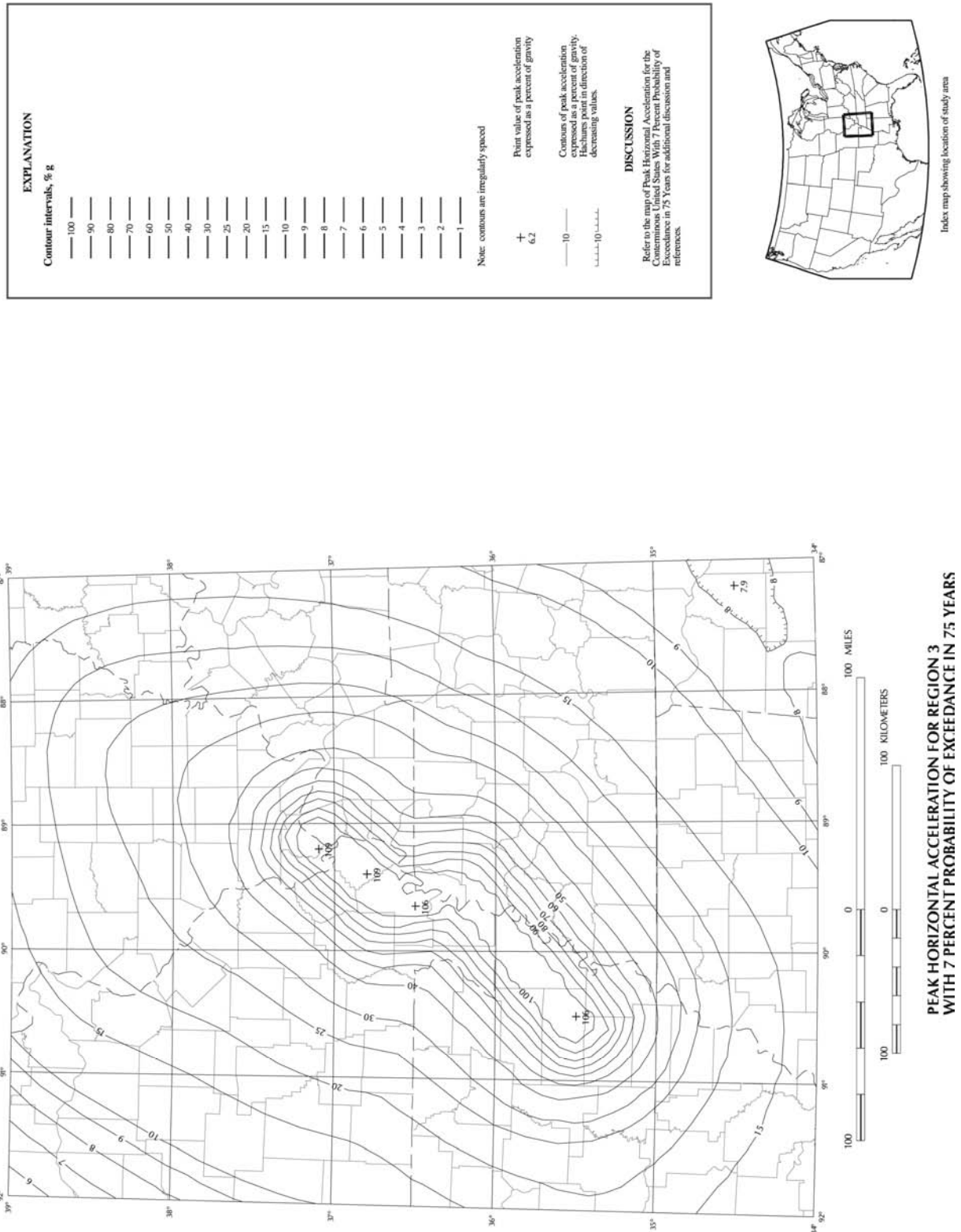

Figure 3.10.2.1-10—Horizontal Peak Ground Acceleration Coefficient for Region 3 (PGA) with Seven Percent Probability of Exceedance in 75 yr (Approx. 1000-yr Return Period)

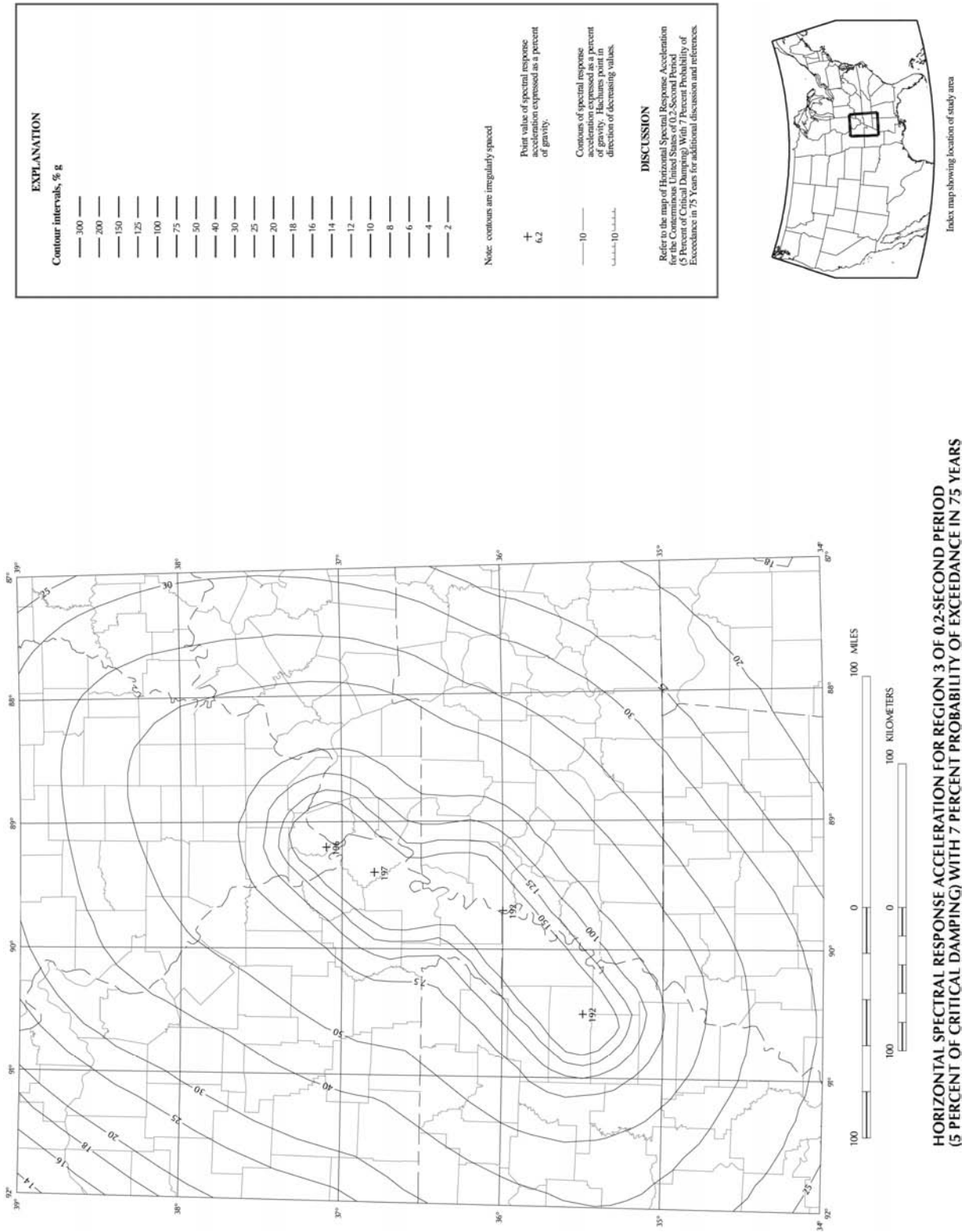

Figure 3.10.2.1-11—Horizontal Response Spectral Acceleration Coefficient for Region 3 at Period of 0.2 s (S_S) with Seven Percent Probability of Exceedance in 75 yr (Approx. 1000-yr Return Period) and Five Percent Critical Damping

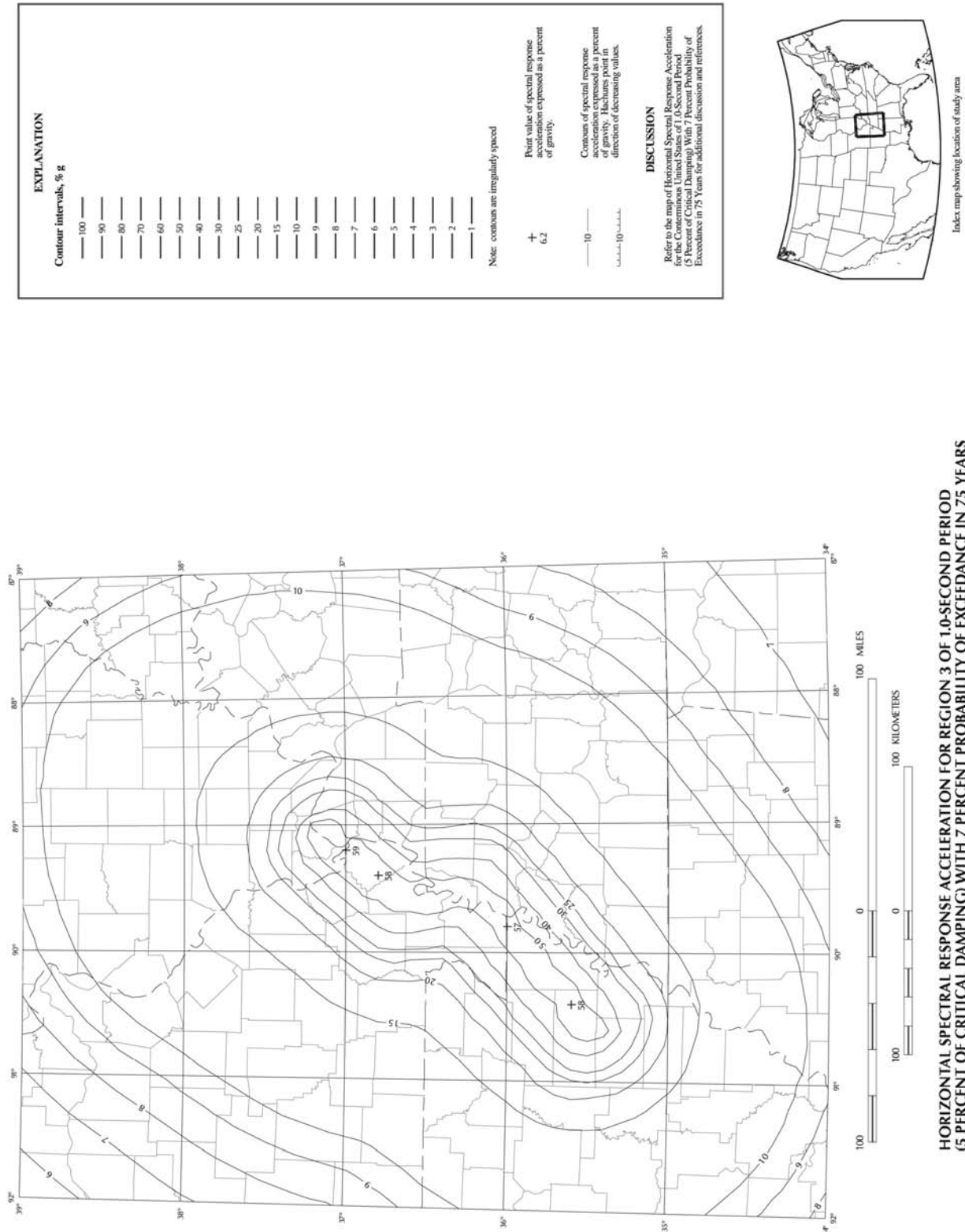

Figure 3.10.2.1-12—Horizontal Response Spectral Acceleration Coefficient for Region 3 at Period of 1.0 s (S_1) with Seven Percent Probability of Exceedance in 75 yr (Approx. 1000-yr Return Period) and Five Percent Critical Damping

**PEAK HORIZONTAL ACCELERATION FOR REGION 4
WITH 7 PERCENT PROBABILITY OF EXCEEDANCE IN 75 YEARS**

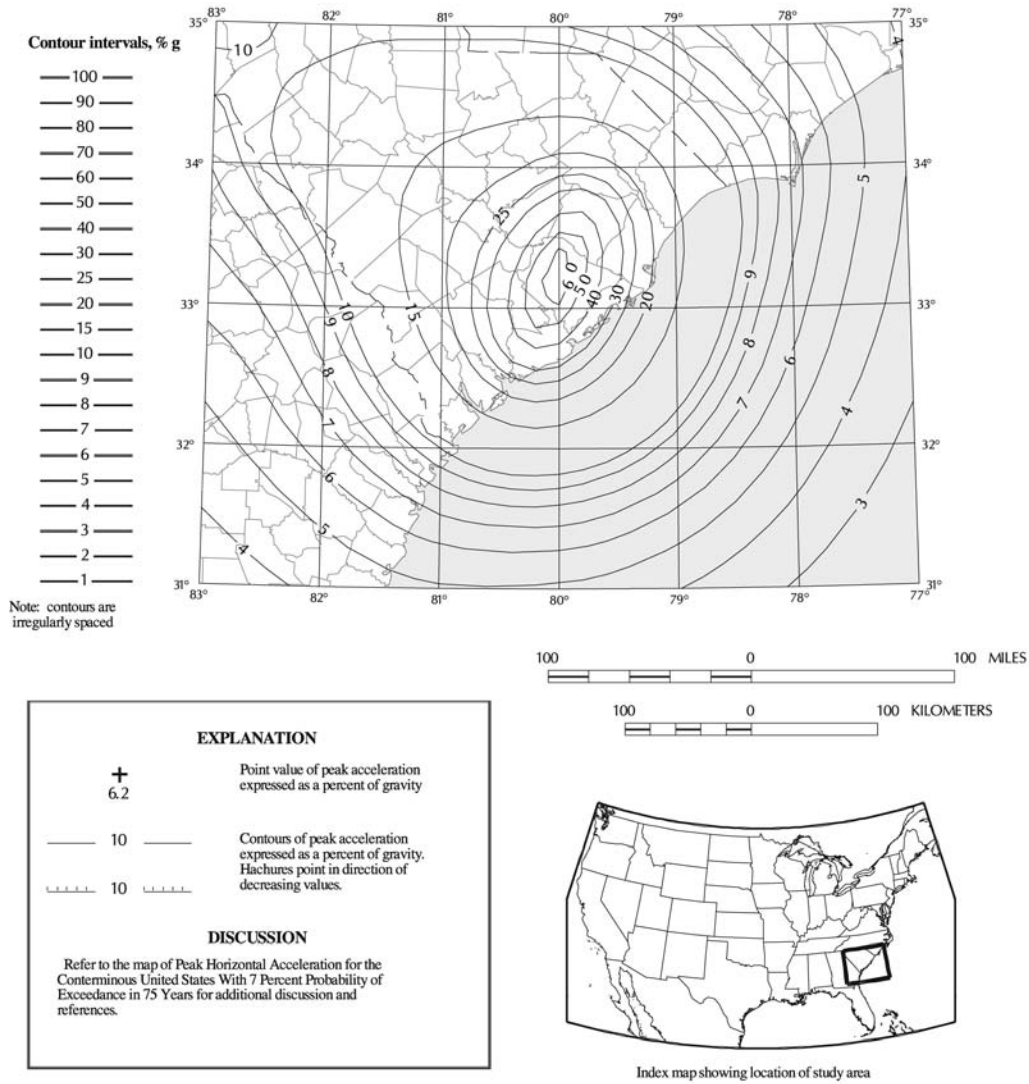

Figure 3.10.2.1-13—Horizontal Peak Ground Acceleration Coefficient for Region 4 (PGA) with Seven Percent Probability of Exceedance in 75 yr (Approx. 1000-yr Return Period)

HORIZONTAL SPECTRAL RESPONSE ACCELERATION FOR REGION 4 OF 0.2- AND 1.0-SECOND PERIOD (5 PERCENT OF CRITICAL DAMPING) WITH 7 PERCENT PROBABILITY OF EXCEEDANCE IN 75 YEARS

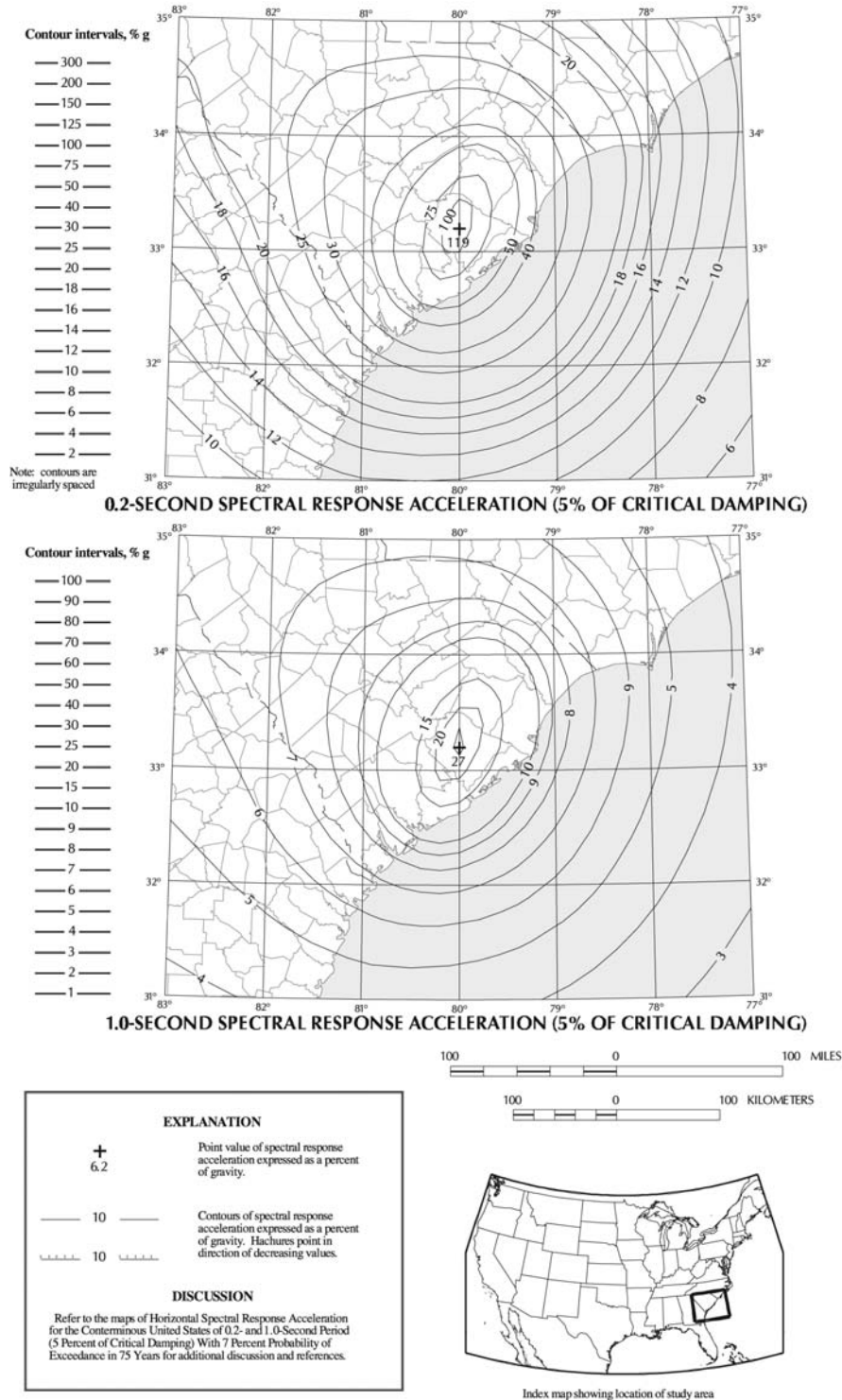
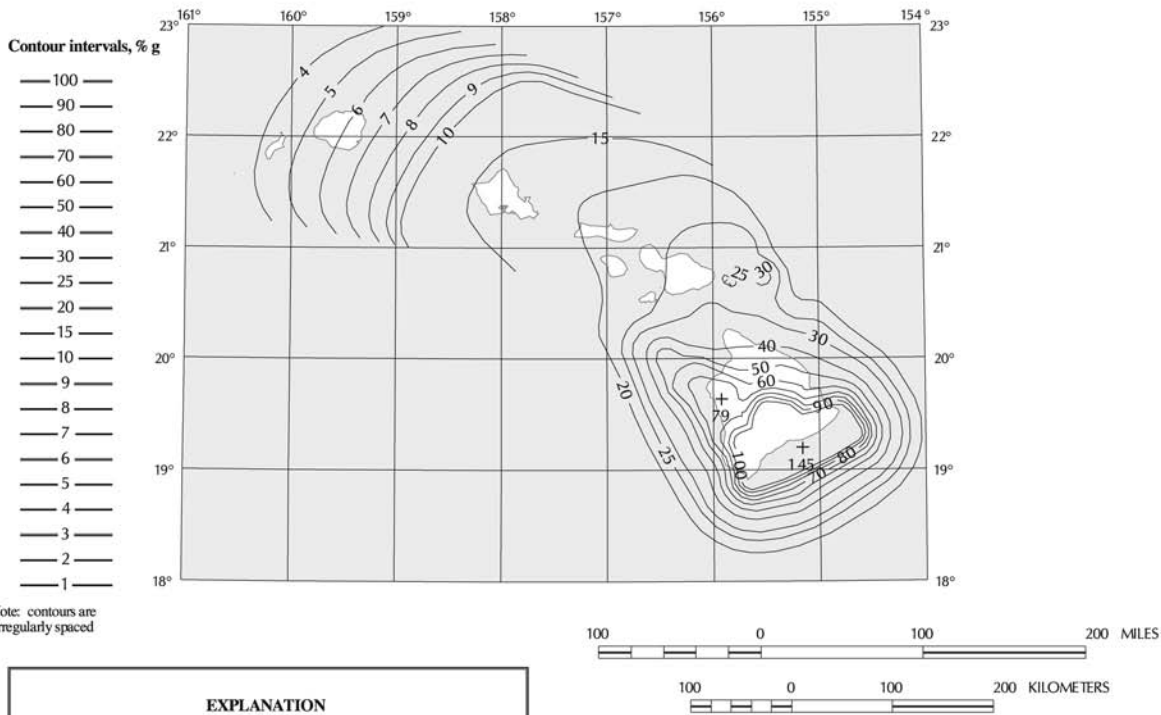

Figure 3.10.2.1-14—Horizontal Response Spectral Acceleration Coefficients for Region 4 at Periods of 0.2 s (S_0) and 1.0 s (S_1) with Seven Percent Probability of Exceedance in 75 yr (Approx. 1000-yr Return Period) and Five Percent Critical Damping

**PEAK HORIZONTAL ACCELERATION FOR HAWAII
WITH 7 PERCENT PROBABILITY OF EXCEEDANCE IN 75 YEARS**



Note: contours are irregularly spaced

EXPLANATION

+
6.2 Point value of peak acceleration expressed as a percent of gravity

— 10 — Contours of peak acceleration expressed as a percent of gravity. Hachures point in direction of decreasing values.

----- 10 -----

DISCUSSION

The acceleration values contoured on this map are for the random horizontal component of acceleration. For design purposes, the reference site condition for the map is to be taken as Site Class B.

Leyendecker, Frankel, and Rukstales (2007) have prepared a CD-ROM that contains software to allow determination of Site Class B map values by latitude-longitude. The software on the CD contains site coefficients that allow the user to adjust map values for different Site Classes. Additional maps at different scales are also included on the CD. The CD was prepared using the same data as that used to prepare the USGS Probabilistic Earthquake Ground Motion maps.

The National Seismic Hazard Mapping Web Site, <http://earthquake.usgs.gov/research/hazmaps> contains information about maps, data, and documentation for seismic hazard maps.

Map prepared by U.S. Geological Survey.

REFERENCES

Imbsen, R., 2007, Proposed AASHTO Guide Specifications for LRFD Seismic Bridge Design, Imbsen Consulting.

Klein, F., Frankel, A., Mueller, C., Wesson, R. and Okubo, P., 2001, Seismic hazard in Hawaii: high rate of large earthquakes and probabilistic ground-motion maps, Bull. Seism. Soc. Am., v. 91, pp. 479-498.

Leyendecker, E., Frankel, A., and Rukstales, K., 2007, Seismic Design Parameters for AASHTO Guide Specifications for LRFD Seismic Bridge Design.

U. S. Geological Survey, National Seismic Hazard Mapping Project Web Site, <http://earthquake.usgs.gov/research/hazmaps>.

Figure 3.10.2.1-15—Horizontal Peak Ground Acceleration Coefficient for Hawaii (PGA) with Seven Percent Probability of Exceedance in 75 yr (Approx. 1000-yr Return Period)

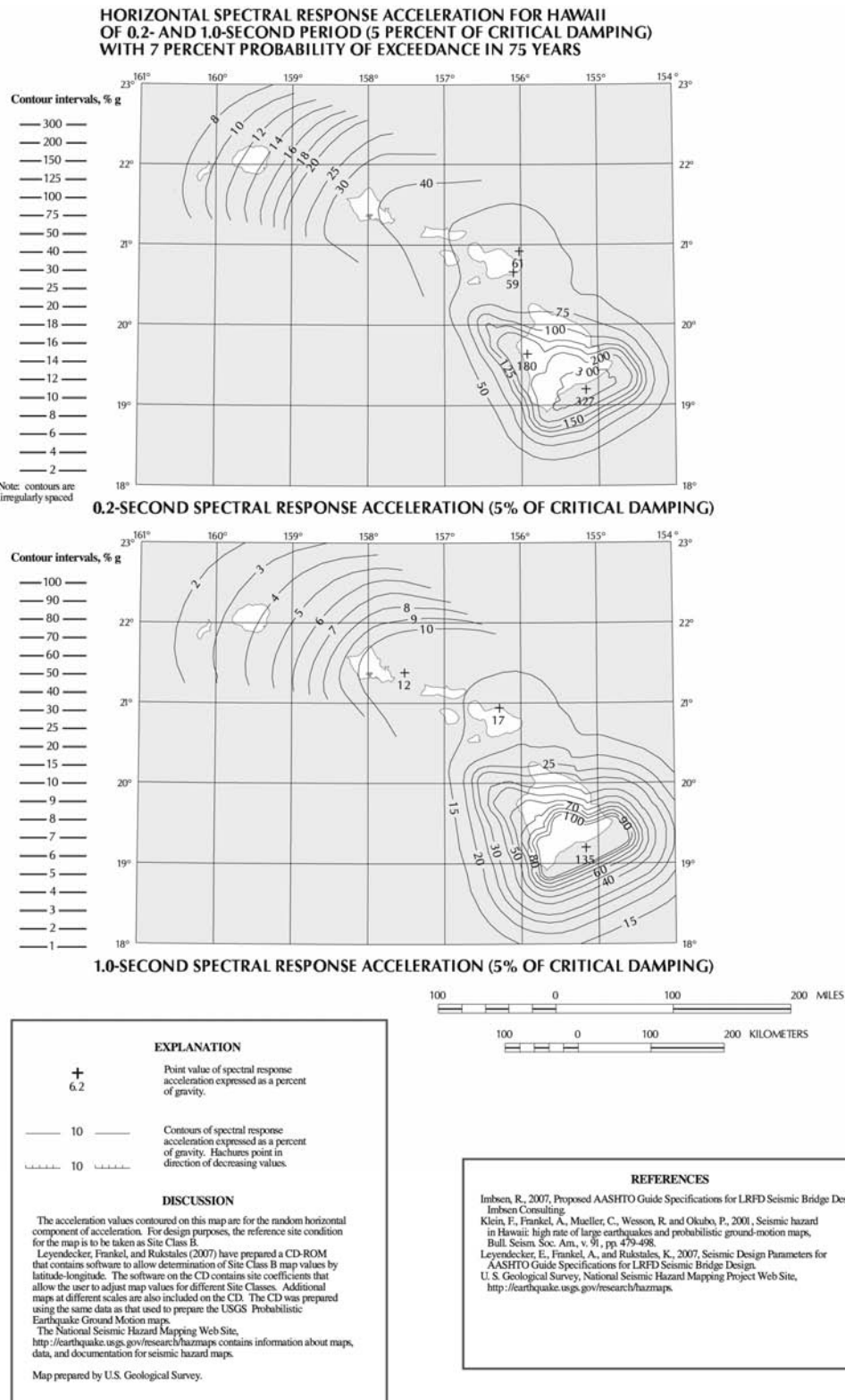

Figure 3.10.2.1-16—Horizontal Response Spectral Acceleration Coefficients for Hawaii at Periods of 0.2 s (S_0) and 1.0 s (S_1) with Seven Percent Probability of Exceedance in 75 yr (Approx. 1000-yr Return Period) and Five Percent Critical Damping

PEAK HORIZONTAL ACCELERATION FOR ALASKA WITH 7 PERCENT PROBABILITY OF EXCEEDANCE IN 75 YEARS

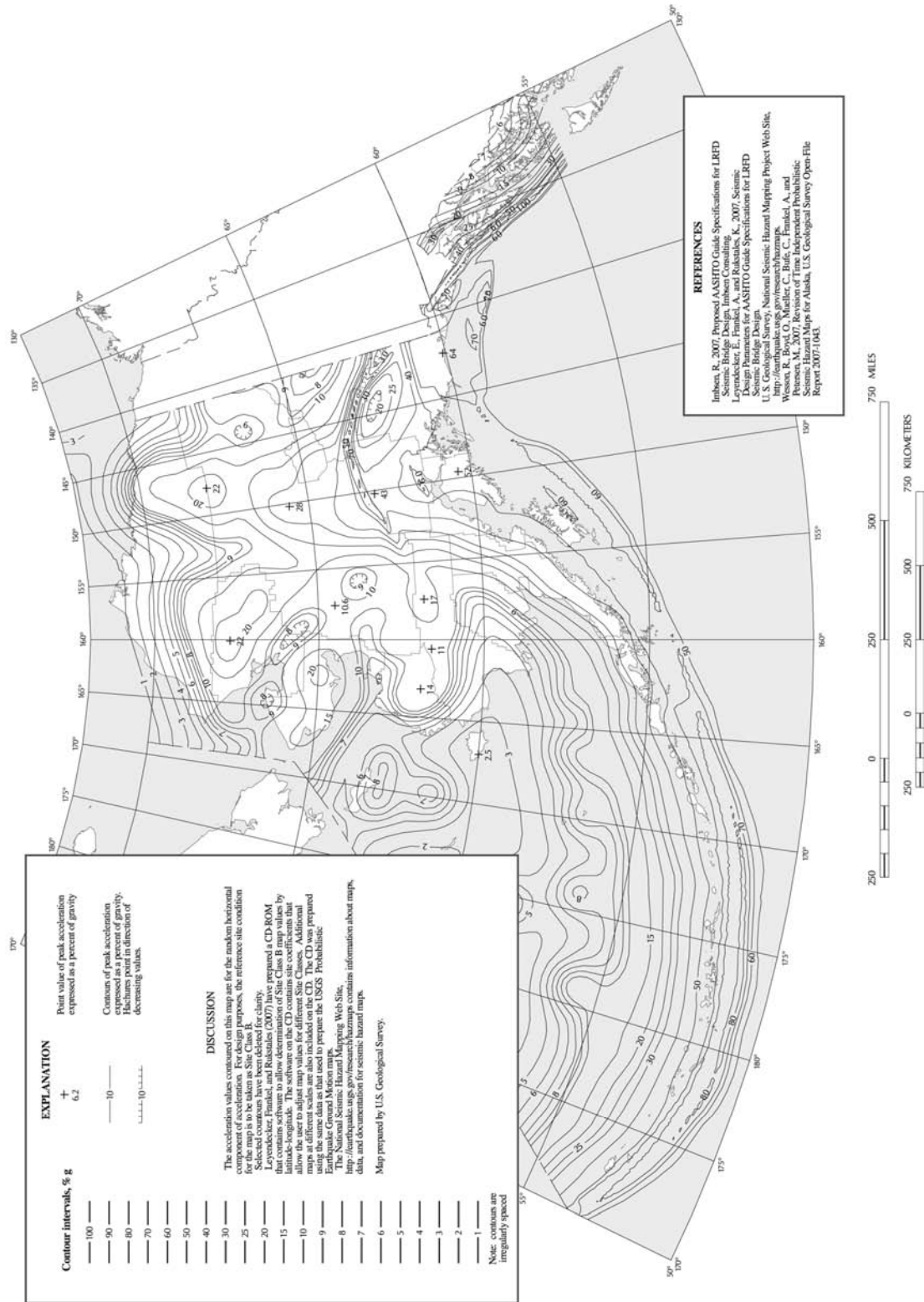

Figure 3.10.2.1-17—Horizontal Peak Ground Acceleration Coefficient for Alaska (PGA) with Seven Percent Probability of Exceedance in 75 yr (Approx. 1000-yr Return Period)

**HORIZONTAL SPECTRAL RESPONSE ACCELERATION FOR ALASKA OF 0.2-SECOND PERIOD
(5 PERCENT OF CRITICAL DAMPING) WITH 7 PERCENT PROBABILITY OF EXCEEDANCE IN 75 YEARS**

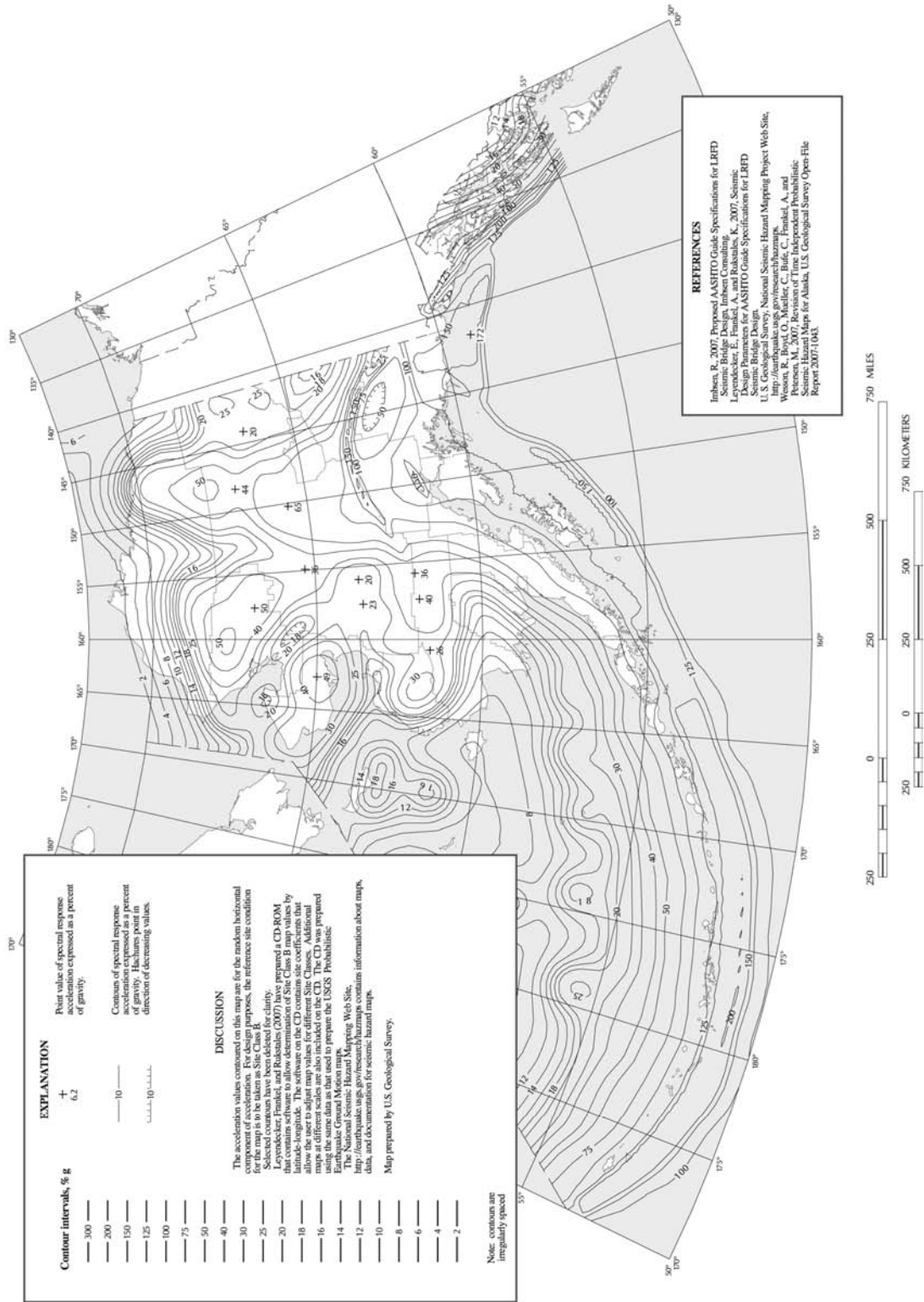

Figure 3.10.2.1-18—Horizontal Response Spectral Acceleration Coefficient for Alaska at Period of 0.2 s (S_S) with Seven Percent Probability of Exceedance in 75 yr (Approx. 1000-yr Return Period) and Five Percent Critical Damping

**HORIZONTAL SPECTRAL RESPONSE ACCELERATION FOR ALASKA OF 1.0-SECOND PERIOD
(5 PERCENT OF CRITICAL DAMPING) WITH 7 PERCENT PROBABILITY OF EXCEEDANCE IN 75 YEARS**

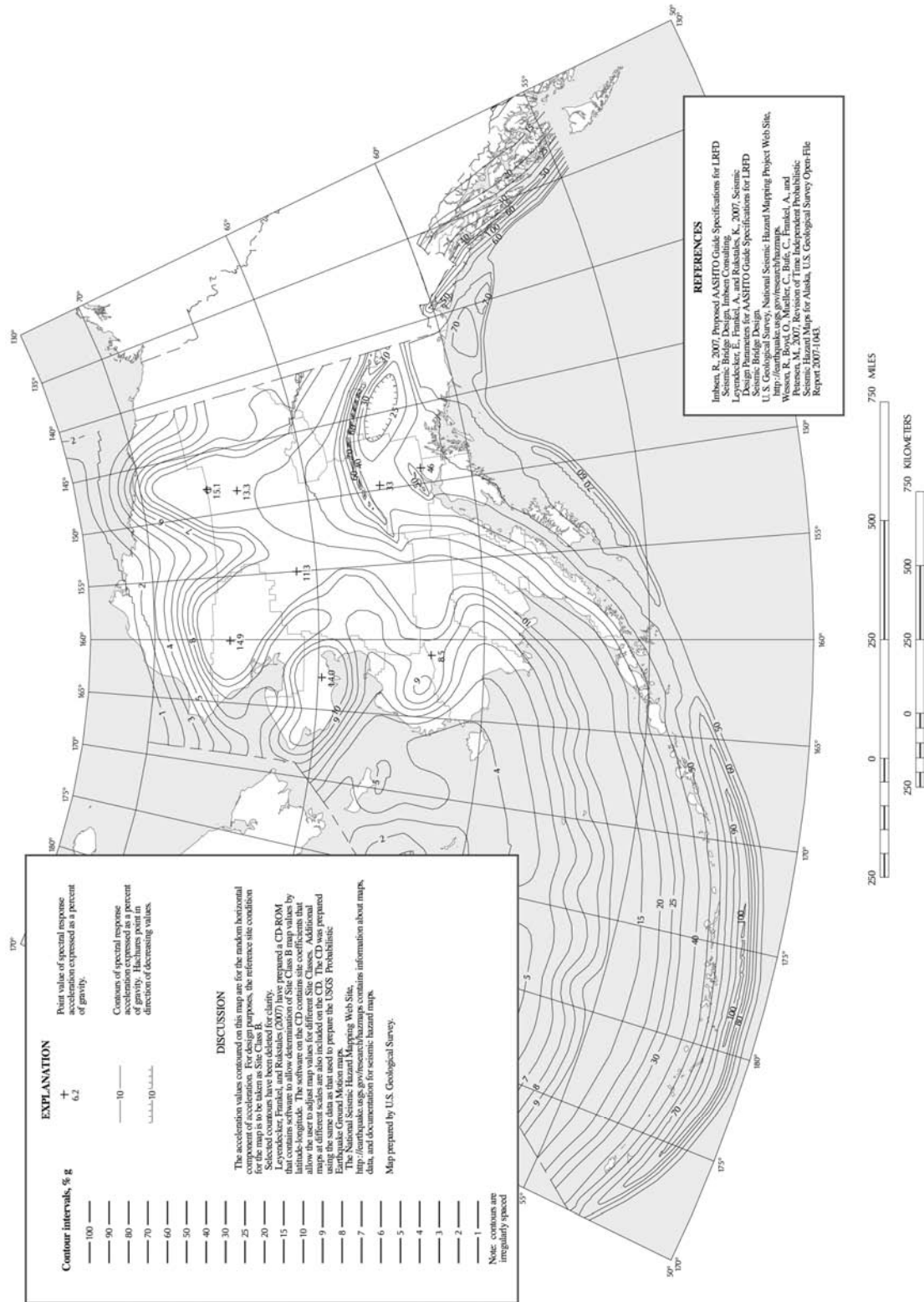

Figure 3.10.2.1-19—Horizontal Response Spectral Acceleration Coefficient for Alaska at Period of 1.0 s (S_1) with Seven Percent Probability of Exceedance in 75 yr (Approx. 1000-yr Return Period) and Five Percent Critical Damping

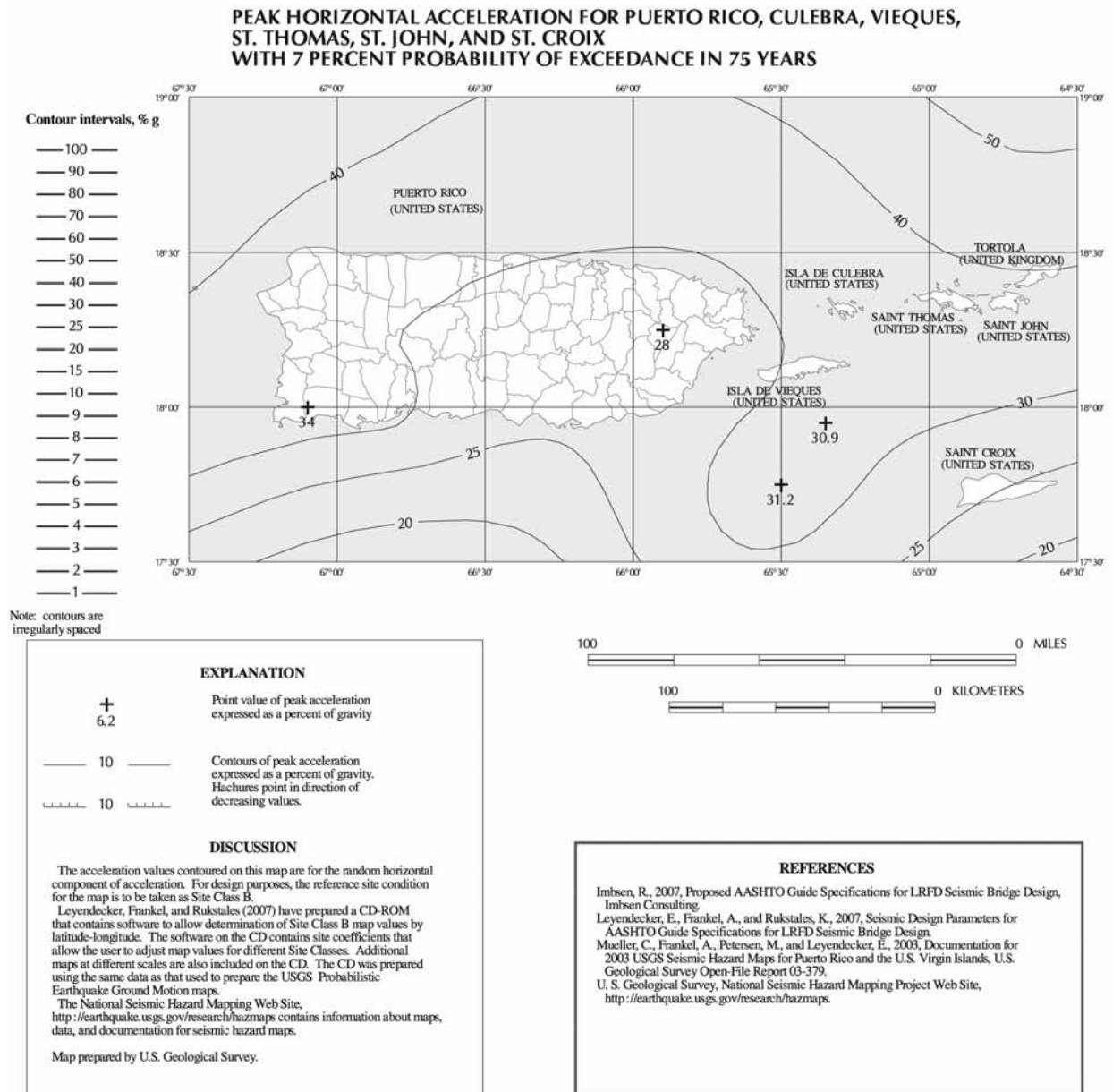

Figure 3.10.2.1-20—Horizontal Peak Ground Acceleration Coefficient for Puerto Rico, Culebra, Vieques, St. Thomas, St. John, and St. Croix (PGA) with Seven Percent Probability of Exceedance in 75 yr (Approx. 1000-yr Return Period)

**HORIZONTAL SPECTRAL RESPONSE ACCELERATION FOR
PUERTO RICO, CULEBRA, VIEQUES, ST. THOMAS, ST. JOHN, AND ST. CROIX
OF 0.2- AND 1.0-SECOND PERIOD (5 PERCENT OF CRITICAL DAMPING)
WITH 7 PERCENT PROBABILITY OF EXCEEDANCE IN 75 YEARS**

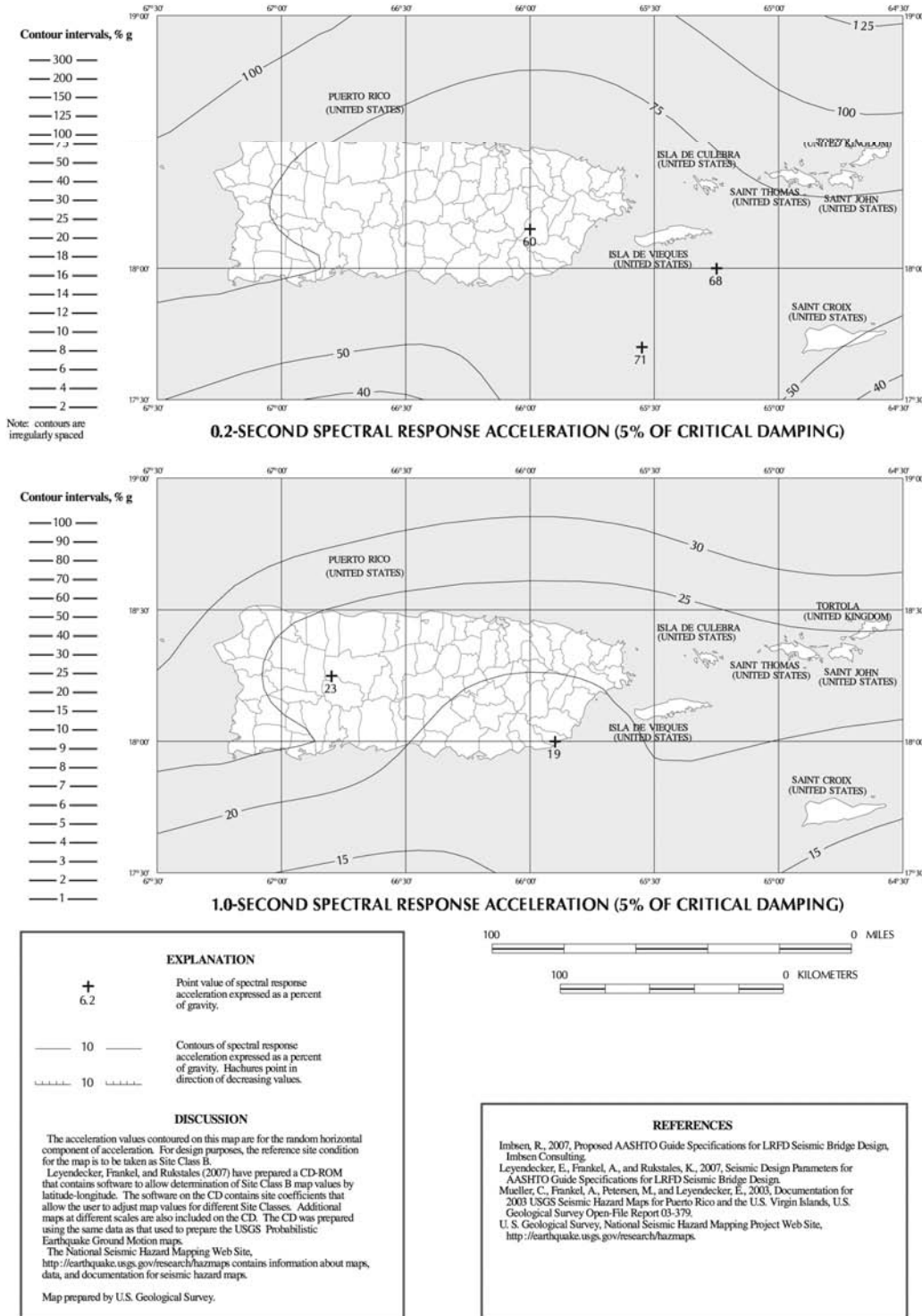

Figure 3.10.2.1-21—Horizontal Response Spectral Acceleration Coefficients for Puerto Rico, Culebra, Vieques, St. Thomas, St. John, and St. Croix at Periods of 0.2 s (S_0) and 1.0 s (S_1) with Seven Percent Probability of Exceedance in 75 yr (Approx. 1000-yr Return Period) and Five Percent Critical Damping

3.10.2.2—Site Specific Procedure

A site-specific procedure to develop design response spectra of earthquake ground motions shall be performed when required by Article 3.10.2 and may be performed for any site. The objective of the site-specific probabilistic ground-motion analysis should be to generate a uniform-hazard acceleration response spectrum considering a seven percent probability of exceedance in 75 yr for spectral values over the entire period range of interest. This analysis should involve establishing:

- The contributing seismic sources;
- An upper-bound earthquake magnitude for each source zone;
- Median attenuation relations for acceleration response spectral values and their associated standard deviations;
- A magnitude-recurrence relation for each source zone; and
- A fault-rupture-length relation for each contributing fault.

Uncertainties in source modeling and parameter values shall be taken into consideration. Detailed documentation of ground-motion analysis is required and shall be peer reviewed.

Where analyses to determine site soil response effects are required by Articles 3.10.3.1 for Site Class F soils, the influence of the local soil conditions shall be determined based on site-specific geotechnical investigations and dynamic site response analyses.

For sites located within 6 miles of an active surface or a shallow fault, as depicted in the USGS Active Fault Map, studies shall be considered to quantify near-fault effects on ground motions to determine if these could significantly influence the bridge response.

A deterministic spectrum may be utilized in regions having known active faults if the deterministic spectrum is no less than two-thirds of the probabilistic spectrum in the region of $0.5T_F$ to $2T_F$ of the spectrum where T_F is the bridge fundamental period. Where use of a deterministic spectrum is appropriate, the spectrum shall be either:

- the envelope of a median spectra calculated for characteristic maximum magnitude earthquakes on known active faults; or
- a deterministic spectra may be defined for each fault, and, in the absence of a clearly controlling spectra, each spectrum should be used.

C3.10.2.2

The intent in conducting a site-specific probabilistic ground motion study is to develop ground motions that are more accurate for the local seismic and site conditions than can be determined from national ground motion maps and the procedure of Article 3.10.2.1. Accordingly, such studies should be comprehensive and incorporate current scientific interpretations at a regional scale. Because there are typically scientifically credible alternatives for models and parameter values used to characterize seismic sources and ground-motion attenuation, it is important to incorporate these uncertainties formally in a site-specific probabilistic analysis. Examples of these uncertainties include seismic source location, extent and geometry; maximum earthquake magnitude; earthquake recurrence rate; and ground-motion attenuation relationship.

Near-fault effects on horizontal response spectra include:

- Higher ground motions due to the proximity of the active fault;
- Directivity effects that increase ground motions for periods greater than 0.5 s if the fault rupture propagates toward the site; and
- Directionality effects that increase ground motions for periods greater than 0.5 s in the direction normal (perpendicular) to the strike of the fault.

If the active fault is included and appropriately modeled in the development of national ground motion maps, then the first effect above is already included in the national ground motion maps. The second and third effects are not included in the national maps. These effects are significant only for periods longer than 0.5 s and normally would be evaluated only for essential or critical bridges having natural periods of vibration longer than 0.5 s. Further discussions of the second and third effects are contained in Somerville (1997) and Somerville et al. (1997).

The fault-normal component of near-field ($D < 6$ mi.) motion may contain relatively long-duration velocity pulses which can cause severe nonlinear structural response, predictable only through nonlinear time-history analyses. For this case the recorded near-field horizontal components of motion need to be transformed into principal components before modifying them to be response-spectrum-compatible.

The ratio of vertical-to-horizontal ground motions increases for short-period motions in the near-fault environment.

Where response spectra are determined from a site-specific study, the spectra shall not be lower than two-thirds of the response spectra determined using the general procedure of Article 3.10.2.1 in the region of $0.5T_F$ to $2T_F$ of the spectrum where T_F is the bridge fundamental period.

3.10.3—Site Effects

Site classes and site factors specified herein shall be used in the General Procedure for characterizing the seismic hazard specified in Article 3.10.4.

3.10.3.1—Site Class Definitions

A site shall be classified as A through F in accordance with the site class definitions in Table 3.10.3.1-1. Sites shall be classified by their stiffness as determined by the shear wave velocity in the upper 100 ft. Standard Penetration Test (SPT), blow counts and undrained shear strengths of soil samples from soil borings may also be used to classify sites as indicated in Table 3.10.3.1-1.

C3.10.3

The behavior of a bridge during an earthquake is strongly related to the soil conditions at the site. Soils can amplify ground motions in the underlying rock, sometimes by factors of two or more. The extent of this amplification is dependent on the profile of soil types at the site and the intensity of shaking in the rock below. Sites are classified by type and profile for the purpose of defining the overall seismic hazard, which is quantified as the product of the soil amplification and the intensity of shaking in the underlying rock.

C3.10.3.1

Steps that may be followed to classify a site are given in Table C3.10.3.1-1.

Table 3.10.3.1-1—Site Class Definitions

Site Class	Soil Type and Profile
A	Hard rock with measured shear wave velocity, $\bar{v}_s > 5,000$ ft/s
B	Rock with $2,500$ ft/sec $< \bar{v}_s < 5,000$ ft/s
C	Very dense soil and soil rock with $1,200$ ft/sec $< \bar{v}_s < 2,500$ ft/s, or with either $\bar{N} > 50$ blows/ft, or $\bar{s}_u > 2.0$ ksf
D	Stiff soil with 600 ft/s $< \bar{v}_s < 1,200$ ft/s, or with either $15 < \bar{N} < 50$ blows/ft, or $1.0 < \bar{s}_u < 2.0$ ksf
E	Soil profile with $\bar{v}_s < 600$ ft/s or with either $\bar{N} < 15$ blows/ft or $\bar{s}_u < 1.0$ ksf, or any profile with more than 10 ft of soft clay defined as soil with $PI > 20$, $w > 40$ percent and $\bar{s}_u < 0.5$ ksf
F	Soils requiring site-specific evaluations, such as: <ul style="list-style-type: none"> • Peats or highly organic clays ($H > 10$ ft of peat or highly organic clay where H = thickness of soil) • Very high plasticity clays ($H > 25$ ft with $PI > 75$) • Very thick soft/medium stiff clays ($H > 120$ ft)

Exceptions: Where the soil properties are not known in sufficient detail to determine the site class, a site investigation shall be undertaken sufficient to determine the site class. Site classes E or F should not be assumed unless the authority having jurisdiction determines that site classes E or F could be present at the site or in the event that site classes E or F are established by geotechnical data.

where:

- \bar{v}_s = average shear wave velocity for the upper 100 ft of the soil profile
- \bar{N} = average Standard Penetration Test (SPT) blow count (blows/ft) (ASTM D1586) for the upper 100 ft of the soil profile
- \bar{s}_u = average undrained shear strength in ksf (ASTM D2166 or ASTM D2850) for the upper 100 ft of the soil profile
- PI = plasticity index (ASTM D4318)
- w = moisture content (ASTM D2216)

Table C3.10.3.1-1—Steps for Site Classification

Step	Description
1	Check for the three categories of Site Class F in Table 3.10.3.1-1 requiring site-specific evaluation. If the site corresponds to any of these categories, classify the site as Site Class F and conduct a site-specific evaluation.
2	Check for existence of a soft layer with total thickness > 10 ft, where soft layer is defined by $s_u < 0.5$ ksf, $w > 40\%$, and $PI > 20$. If these criteria are met, classify site as Site Class E.
3	<p>Categorize the site into one of the site classes in Table 3.10.3.1-1 using one of the following three methods to calculate:</p> <ul style="list-style-type: none"> • \bar{v}_s for the top 100 ft (\bar{v}_s method) • \bar{N} for the top 100 ft (\bar{N} method) • \bar{N}_{ch} for cohesionless soil layers ($PI < 20$) in the top 100 ft and \bar{s}_u for cohesive soil layers ($PI > 20$) in the top 100 ft (\bar{s}_u method) <p>To make these calculations, the soil profile is subdivided into n distinct soil and rock layers, and in the methods below the symbol i refers to any one of these layers from 1 to n.</p> <p>Method A: \bar{v}_s method</p> <p>The average \bar{v}_s for the top 100 ft is determined as:</p> $\bar{v}_s = \frac{\sum_{i=1}^n d_i}{\sum_{i=1}^n \frac{d_i}{v_{si}}}$ <p>where:</p> $\sum_{i=1}^n d_i = 100 \text{ ft}$ <p>v_{si} = shear wave velocity in ft/s of a layer</p> <p>d_i = thickness of a layer between 0 and 100 ft</p> <p>Method B: \bar{N} method</p> <p>The average \bar{N} for the top 100 ft shall be determined as:</p> $\bar{N} = \frac{\sum_{i=1}^n d_i}{\sum_{i=1}^n \frac{d_i}{N_i}}$ <p>where:</p> <p>N_i = Standard Penetration Test blow count of a layer (not to exceed 100 blows/ft in the above expression)</p>

Note: When using Method B, \bar{N} values are for cohesionless soils and cohesive soil and rock layers within the upper 100 ft. Where refusal is met for a rock layer, N_i should be taken as 100 blows/ft.

Table C3.10.3.1-1 (continued)—Steps for Site Classification

<p>Method C: \bar{s}_u method</p> <p>The average \bar{N}_{ch} for cohesionless soil layers in the top 100 ft is determined as:</p> $\bar{N}_{ch} = \frac{d_s}{\sum_{i=1}^m \frac{d_i}{N_{chi}}}$ <p>in which:</p> $\sum_{i=1}^m d_i = d_s,$ <p>where:</p> <p>m = number of cohesionless soil layers in the top 100 ft N_{chi} = blow count for a cohesionless soil layer (not to exceed 100 blows/ft in the above expression) d_s = total thickness of cohesionless soil layers in the top 100 ft</p> <p>The average \bar{s}_u for cohesive soil layers in the top 100 ft is determined as:</p> $\bar{s}_u = \frac{d_c}{\sum_{i=1}^k \frac{d_i}{s_{ui}}}$ <p>in which:</p> $\sum_{i=1}^k d_i = d_c,$ <p>where:</p> <p>k = number of cohesive soil layers in the top 100 ft s_{ui} = undrained shear strength for a cohesive soil layer (not to exceed 5.0 ksf in the above expression) d_c = total thickness of cohesive soil layers in the top 100 ft</p>
--

Note: When using Method C, if the site class resulting from \bar{N}_{ch} and \bar{s}_u differ, select the site class that gives the highest site factors and design spectral response in the period range of interest. For example, if \bar{N}_{ch} was equal to 20 blows/ft and \bar{s}_u was equal to 0.8 ksf, the site would classify as D or E in accordance with Method C and the site class definitions of Table 3.10.3.1-1. In this example, for relatively low response spectral acceleration and for long-period motions, Table 3.10.3.2-3 indicates that the site factors are highest for Site Class E. However, for relatively high short-period spectral acceleration ($S_s > 0.75$), short period site factors, F_a , are higher for Site Class D.

3.10.3.2—Site Factors

Site Factors F_{pga} , F_a and F_v specified in Tables 3.10.3.2-1, 3.10.3.2-2, and 3.10.3.2-3 shall be used in the zero-period, short-period range, and long-period range, respectively. These factors shall be determined using the Site Class given in Table 3.10.3.1-1 and the mapped values of the coefficients PGA , S_S , and S_1 in Figures 3.10.2.1-1 to 3.10.2.1-21.

C3.10.3.2

Site Class B (soft rock) is taken to be the reference site category for the USGS and NEHRP MCE ground shaking maps. Site class B rock is therefore the site condition for which the site factor is 1.0. Site classes A, C, D, and E have separate sets of site factors for zero-period (F_{pga}), the short-period range (F_a) and long-period range (F_v), as indicated in Tables 3.10.3.2-1, 3.10.3.2-2, and 3.10.3.2-3. These site factors generally increase as the soil profile becomes softer (in going from site class A to E). Except for site class A (hard rock), the factors also decrease as the ground motion level increases, due to the strongly nonlinear behavior of the soil. For a given site class, C, D, or E, these nonlinear site factors increase the ground motion more in areas having lower rock ground motions than in areas having higher rock ground motions.

Table 3.10.3.2-1—Values of Site Factor, F_{pga} , at Zero-Period on Acceleration Spectrum

Site Class	Peak Ground Acceleration Coefficient (PGA) ¹				
	$PGA < 0.10$	$PGA = 0.20$	$PGA = 0.30$	$PGA = 0.40$	$PGA > 0.50$
A	0.8	0.8	0.8	0.8	0.8
B	1.0	1.0	1.0	1.0	1.0
C	1.2	1.2	1.1	1.0	1.0
D	1.6	1.4	1.2	1.1	1.0
E	2.5	1.7	1.2	0.9	0.9
F ²	*	*	*	*	*

Notes:

¹Use straight-line interpolation for intermediate values of PGA .

²Site-specific geotechnical investigation and dynamic site response analysis should be performed for all sites in Site Class F.

Table 3.10.3.2-2—Values of Site Factor, F_a , for Short-Period Range of Acceleration Spectrum

Site Class	Spectral Acceleration Coefficient at Period 0.2 sec (S_S) ¹				
	$S_S < 0.25$	$S_S = 0.50$	$S_S = 0.75$	$S_S = 1.00$	$S_S > 1.25$
A	0.8	0.8	0.8	0.8	0.8
B	1.0	1.0	1.0	1.0	1.0
C	1.2	1.2	1.1	1.0	1.0
D	1.6	1.4	1.2	1.1	1.0
E	2.5	1.7	1.2	0.9	0.9
F ²	*	*	*	*	*

Notes:

¹Use straight-line interpolation for intermediate values of S_S .

²Site-specific geotechnical investigation and dynamic site response analysis should be performed for all sites in Site Class F.

Table 3.10.3.2-3—Values of Site Factor, F_v , for Long-Period Range of Acceleration Spectrum

Site Class	Spectral Acceleration Coefficient at Period 1.0 sec (S_1) ¹				
	$S_1 < 0.1$	$S_1 = 0.2$	$S_1 = 0.3$	$S_1 = 0.4$	$S_1 > 0.5$
A	0.8	0.8	0.8	0.8	0.8
B	1.0	1.0	1.0	1.0	1.0
C	1.7	1.6	1.5	1.4	1.3
D	2.4	2.0	1.8	1.6	1.5
E	3.5	3.2	2.8	2.4	2.4
F ²	*	*	*	*	*

Notes:

¹Use straight-line interpolation for intermediate values of S_1 .

²Site-specific geotechnical investigation and dynamic site response analysis should be performed for all sites in Site Class F.

3.10.4—Seismic Hazard Characterization

3.10.4.1—Design Response Spectrum

The five-percent-damped-design response spectrum shall be taken as specified in Figure 3.10.4.1-1. This spectrum shall be calculated using the mapped peak ground acceleration coefficients and the spectral acceleration coefficients from Figures 3.10.2.1-1 to 3.10.2.1-21, scaled by the zero-, short-, and long-period site factors, F_{pga} , F_a , and F_v , respectively.

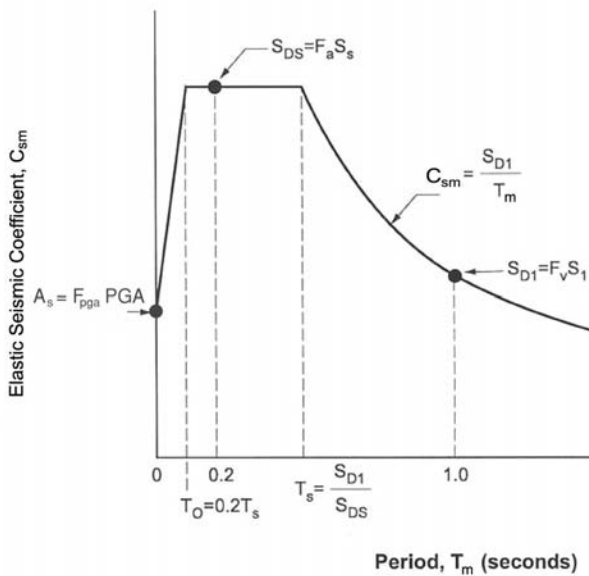

Figure 3.10.4.1-1—Design Response Spectrum

C3.10.4.1

The long-period portion of the response spectrum in Figure 3.10.4.1-1 is inversely proportional to the period, T . In the previous edition of these Specifications, this portion of the spectrum was inversely proportional to $T^{2/3}$. The consequence of this change is that spectral accelerations at periods greater than 1.0 s are smaller than previously specified (for the same ground acceleration and soil type), and greater than previously specified for periods less than 1.0 s (but greater than T_s). This change is consistent with the observed characteristics of response spectra calculated from recorded ground motions. This revised shape is recommended in recent publications by NCHRP (2002, 2006), MCEER/ATC (2003), and FHWA (2006).

For periods exceeding about 3 s, it has been observed that in certain seismic environments spectral displacements tend to a constant value which implies that the acceleration spectrum becomes inversely proportional to T^2 at these periods. As a consequence, the spectrum in Figure 3.10.4.1-1 (and Eq. 3.10.4.2-5) may give conservative results for long period bridges (greater than about 3 s).

3.10.4.2—Elastic Seismic Response Coefficient

For periods less than or equal to T_0 , the elastic seismic coefficient for the m th mode of vibration, C_{sm} , shall be taken as:

$$C_{sm} = A_S + (S_{DS} - A_S) (T_m / T_0) \quad (3.10.4.2-1)$$

in which:

$$A_S = F_{pga} PGA \quad (3.10.4.2-2)$$

$$S_{DS} = F_a S_S \quad (3.10.4.2-3)$$

where:

- PGA = peak ground acceleration coefficient on rock (Site Class B)
 S_S = horizontal response spectral acceleration coefficient at 0.2-sec period on rock (Site Class B)
 T_m = period of vibration of m th mode (s)
 T_0 = reference period used to define spectral shape = $0.2 T_S$ (s)
 T_S = corner period at which spectrum changes from being independent of period to being inversely proportional to period = S_{D1}/S_{DS} (s)

For periods greater than or equal to T_0 and less than or equal to T_S , the elastic seismic response coefficient shall be taken as:

$$C_{sm} = S_{DS} \quad (3.10.4.2-4)$$

For periods greater than T_S , the elastic seismic response coefficient shall be taken as:

$$C_{sm} = S_{D1} / T_m \quad (3.10.4.2-5)$$

in which:

$$S_{D1} = F_v S_1 \quad (3.10.4.2-6)$$

where:

- S_1 = horizontal response spectral acceleration coefficient at 1.0 sec period on rock (Site Class B)

3.10.5—Operational Classification

For the purpose of Article 3.10, the Owner or those having jurisdiction shall classify the bridge into one of three operational categories as follows:

- Critical bridges,
- Essential bridges, or
- Other bridges.

C 3.10.4.2

An earthquake may excite several modes of vibration in a bridge and, therefore, the elastic response coefficient should be found for each relevant mode.

The discussion of the single-mode method in the commentary to Article 4.7.4.3.2 illustrates the relationship between period, C_{sm} , and quasi-static seismic forces, $p_e(x)$. The structure is analyzed for these seismic forces in the single-mode method. In the multimode method, the structure is analyzed for several sets of seismic forces, each corresponding to the period and mode shape of one of the modes of vibration, and the results are combined using acceptable methods, such as the Complete Quadratic Combination method as required in Article 4.7.4.3.3. C_{sm} applies to weight, not mass.

C3.10.5

Essential bridges are generally those that should, as a minimum, be open to emergency vehicles and for security/defense purposes immediately after the design earthquake, i.e., a 1,000-yr return period event. However, some bridges must remain open to all traffic after the design earthquake and be usable by emergency vehicles and for security/defense purposes immediately after a large earthquake, e.g., a 2,500-yr return period event. These bridges should be regarded as critical structures.

The basis of classification shall include social/survival and security/defense requirements. In classifying a bridge, consideration should be given to possible future changes in conditions and requirements.

3.10.6—Seismic Performance Zones

Each bridge shall be assigned to one of the four seismic zones in accordance with Table 3.10.6-1 using the value of S_{D1} given by Eq. 3.10.4.2-6.

Table 3.10.6-1—Seismic Zones

Acceleration Coefficient, S_{D1}	Seismic Zone
$S_{D1} \leq 0.15$	1
$0.15 < S_{D1} \leq 0.30$	2
$0.30 < S_{D1} \leq 0.50$	3
$0.50 < S_{D1}$	4

3.10.7—Response Modification Factors

3.10.7.1—General

To apply the response modification factors specified herein, the structural details shall satisfy the provisions of Articles 5.10.2.2, 5.10.11, and 5.13.4.6.

Except as noted herein, seismic design force effects for substructures and the connections between parts of structures, listed in Table 3.10.7.1-2, shall be determined by dividing the force effects resulting from elastic analysis by the appropriate response modification factor, R , as specified in Tables 3.10.7.1-1 and 3.10.7.1-2, respectively.

As an alternative to the use of the R -factors, specified in Table 3.10.7.1-2 for connections, monolithic joints between structural members and/or structures, such as a column-to-footing connection, may be designed to transmit the maximum force effects that can be developed by the inelastic hinging of the column or multicolumn bent they connect as specified in Article 3.10.9.4.3.

If an inelastic time history method of analysis is used, the response modification factor, R , shall be taken as 1.0 for all substructure and connections.

Table 3.10.7.1-1—Response Modification Factors—Substructures

Substructure	Operational Category		
	Critical	Essential	Other
Wall-type piers—larger dimension	1.5	1.5	2.0
Reinforced concrete pile bents			
• Vertical piles only	1.5	2.0	3.0
• With batter piles	1.5	1.5	2.0
Single columns	1.5	2.0	3.0
Steel or composite steel and concrete pile bents			
• Vertical pile only	1.5	3.5	5.0
• With batter piles	1.5	2.0	3.0
Multiple column bents	1.5	3.5	5.0

C3.10.6

These seismic zones reflect the variation in seismic risk across the country and are used to permit different requirements for methods of analysis, minimum support lengths, column design details, and foundation and abutment design procedures.

C3.10.7.1

These Specifications recognize that it is uneconomical to design a bridge to resist large earthquakes elastically. Columns are assumed to deform inelastically where seismic forces exceed their design level, which is established by dividing the elastically computed force effects by the appropriate R -factor.

R -factors for connections are smaller than those for substructure members in order to preserve the integrity of the bridge under these extreme loads. For expansion joints within the superstructure and connections between the superstructure and abutment, the application of the R -factor results in force effect magnification. Connections that transfer forces from one part of a structure to another include, but are not limited to, fixed bearings, expansion bearings with either restrainers, STUs, or dampers, and shear keys. For one-directional bearings, these R -factors are used in the restrained direction only. In general, forces determined on the basis of plastic hinging will be less than those given by using Table 3.10.7.1-2, resulting in a more economical design.

Table 3.10.7.1-2 Response Modification Factors—Connections

Connection	All Operational Categories
Superstructure to abutment	0.8
Expansion joints within a span of the superstructure	0.8
Columns, piers, or pile bents to cap beam or superstructure	1.0
Columns or piers to foundations	1.0

3.10.7.2—Application

Seismic loads shall be assumed to act in any lateral direction.

The appropriate R-factor shall be used for both orthogonal axes of the substructure.

A wall-type concrete pier may be analyzed as a single column in the weak direction if all the provisions for columns, as specified in Section 5, are satisfied.

3.10.8—Combination of Seismic Force Effects

The elastic seismic force effects on each of the principal axes of a component resulting from analyses in the two perpendicular directions shall be combined to form two load cases as follows:

- 100 percent of the absolute value of the force effects in one of the perpendicular directions combined with 30 percent of the absolute value of the force effects in the second perpendicular direction, and
- 100 percent of the absolute value of the force effects in the second perpendicular direction combined with 30 percent of the absolute value of the force effects in the first perpendicular direction.

Where foundation and/or column connection forces are determined from plastic hinging of the columns specified in Article 3.10.9.4.3, the resulting force effects may be determined without consideration of combined load cases specified herein. For the purpose of this provision, “column connection forces” shall be taken as the shear and moment, computed on the basis of plastic hinging. The axial load shall be taken as that resulting from the appropriate load combination with the axial load, if any, associated with plastic hinging taken as *EQ*. If a pier is designed as a column as specified in Article 3.10.7.2, this exception shall be taken to apply for the weak direction of the pier where force effects resulting from plastic hinging are used; the combination load cases specified must be used for the strong direction of the pier.

C3.10.7.2

Usually the orthogonal axes will be the longitudinal and transverse axes of the bridge. In the case of a curved bridge, the longitudinal axis may be the chord joining the two abutments.

Wall-type piers may be treated as wide columns in the strong direction, provided the appropriate R-factor in this direction is used.

C3.10.8

The exception to these load combinations indicated at the end of this Section should also apply to bridges in Zone 2 where foundation forces are determined from plastic hinging of the columns.

3.10.9—Calculation of Design Forces

3.10.9.1—General

For single-span bridges, regardless of seismic zone, the minimum design connection force effect in the restrained direction between the superstructure and the substructure shall not be less than the product of the acceleration coefficient, A_s , specified in Eq. 3.10.4.2-2, and the tributary permanent load.

Minimum support lengths at expansion bearings of multispan bridges shall either comply with Article 4.7.4.4 or STUs, and dampers shall be provided.

3.10.9.2—Seismic Zone 1

For bridges in Zone 1 where the acceleration coefficient, A_s , as specified in Eq. 3.10.4.2-2, is less than 0.05, the horizontal design connection force in the restrained directions shall not be less than 0.15 times the vertical reaction due to the tributary permanent load and the tributary live loads assumed to exist during an earthquake.

For all other sites in Zone 1, the horizontal design connection force in the restrained directions shall not be less than 0.25 times the vertical reaction due to the tributary permanent load and the tributary live loads assumed to exist during an earthquake.

The horizontal design connection force shall be addressed from the point of application through the substructure and into the foundation elements.

For each uninterrupted segment of a superstructure, the tributary permanent load at the line of fixed bearings, used to determine the longitudinal connection design force, shall be the total permanent load of the segment.

If each bearing supporting an uninterrupted segment or simply supported span is restrained in the transverse direction, the tributary permanent load used to determine the connection design force shall be the permanent load reaction at that bearing.

Each elastomeric bearing and its connection to the masonry and sole plates shall be designed to resist the horizontal seismic design forces transmitted through the bearing. For all bridges in Seismic Zone 1 and all single-span bridges, these seismic shear forces shall not be less than the connection force specified herein.

3.10.9.3—Seismic Zone 2

Structures in Seismic Zone 2 shall be analyzed according to the minimum requirements specified in Articles 4.7.4.1 and 4.7.4.3.

Except for foundations, seismic design forces for all components, including pile bents and retaining walls, shall be determined by dividing the elastic seismic forces, obtained from Article 3.10.8, by the appropriate response modification factor, R , specified in Table 3.10.7.1-1.

C3.10.9.1

This Article refers to superstructure effects carried into substructure. Abutments on multispan bridges, but not single-span bridges, and retaining walls are subject to acceleration-augmented soil pressures as specified in Articles 3.11.4 and 11.6.5. Wingwalls on single-span structures are not fully covered at this time, and the Engineer should use judgment in this area.

C3.10.9.2

These provisions arise because, as specified in Article 4.7.4, seismic analysis for bridges in Zone 1 is not generally required. These default values are used as minimum design forces in lieu of rigorous analysis. The division of Zone 1 at a value for the acceleration coefficient, A_s , of 0.05 recognizes that, in parts of the country with very low seismicity, seismic forces on connections are very small.

If each bearing supporting a continuous segment or simply supported span is an elastomeric bearing, there are no restrained directions due to the flexibility of the bearings.

Lateral connection forces are transferred from the superstructure into the foundation elements through the substructure. The force effects in this load path from seismic and other lateral loads should be addressed in the design. If each bearing supporting a continuous segment or simply supported span is an elastomeric bearing, there may be no fully restrained directions due to the flexibility of the bearings. However, the forces transmitted through these bearings to substructure and foundation elements should be determined in accordance with this Article and Article 14.6.3.

The magnitude of live load assumed to exist at the time of the earthquake should be consistent with the value of γ_{eq} used in conjunction with Table 3.4.1-1.

C3.10.9.3

This Article specifies the design forces for foundations which include the footings, pile caps and piles. The design forces are essentially twice the seismic design forces of the columns. This will generally be conservative and was adopted to simplify the design procedure for bridges in Zone 2. However, if seismic forces do not govern the design of columns and piers there is a possibility that during an earthquake the foundations will

Seismic design forces for foundations, other than pile bents and retaining walls, shall be determined by dividing elastic seismic forces, obtained from Article 3.10.8, by half of the response modification factor, R , from Table 3.10.7.1-1, for the substructure component to which it is attached. The value of $R/2$ shall not be taken as less than 1.0.

Where a group load other than Extreme Event I, specified in Table 3.4.1-1, governs the design of columns, the possibility that seismic forces transferred to the foundations may be larger than those calculated using the procedure specified above, due to possible overstrength of the columns, shall be considered.

be subjected to forces larger than the design forces. For example, this may occur due to unintended column overstrengths which may exceed the capacity of the foundations. An estimate of this effect may be found by using a resistance factor, ϕ , of 1.3 for reinforced concrete columns and 1.25 for structural steel columns. It is also possible that even in cases when seismic loads govern the column design, the columns may have insufficient shear strength to enable a ductile flexural mechanism to develop, but instead allow a brittle shear failure to occur. Again, this situation is due to potential overstrength in the flexural capacity of columns and could possibly be prevented by arbitrarily increasing the column design shear by the overstrength factor cited above.

Conservatism in the design, and in some cases underdesign, of foundations and columns in Zone 2 based on the simplified procedure of this Article has been widely debated (Gajer and Wagh, 1994). In light of the above discussion, it is recommended that for critical or essential bridges in Zone 2 consideration should be given to the use of the forces specified in Article 3.10.9.4.3f for foundations in Zone 3 and Zone 4. Ultimate soil and pile strengths are to be used with the specified foundation seismic design forces.

3.10.9.4—Seismic Zones 3 and 4

3.10.9.4.1—General

Structures in Seismic Zones 3 and 4 shall be analyzed according to the minimum requirements specified in Articles 4.7.4.1 and 4.7.4.3.

The design forces of each component shall be taken as the lesser of those determined using:

- the provisions of Article 3.10.9.4.2; or
- the provisions of Article 3.10.9.4.3,

for all components of a column, column bent and its foundation and connections.

3.10.9.4.2—Modified Design Forces

Modified design forces shall be determined as specified in Article 3.10.9.3, except that for foundations the R -factor shall be taken as 1.0.

3.10.9.4.3—Inelastic Hinging Forces

3.10.9.4.3a—General

Where inelastic hinging is invoked as a basis for seismic design, the force effects resulting from plastic hinging at the top and/or bottom of the column shall be calculated after the preliminary design of the columns has been completed utilizing the modified design forces specified in Article 3.10.9.4.2 as the seismic loads. The

C3.10.9.4.1

In general, the design forces resulting from an R -factor and inelastic hinging analysis will be less than those from an elastic analysis. However, in the case of architecturally oversized column(s), the forces from an inelastic hinging analysis may exceed the elastic forces in which case the elastic forces may be used for that column, column bent and its connections and foundations.

C3.10.9.4.2

Acceptable damage is restricted to inelastic hinges in the columns. The foundations should, therefore, remain in their elastic range. Hence the value for the R -factor is taken as 1.0.

C3.10.9.4.3a

By virtue of Article 3.10.9.4.2, alternative conservative design forces are specified if plastic hinging is not invoked as a basis for seismic design.

In most cases, the maximum force effects on the foundation will be limited by the extreme horizontal force that a column is capable of developing. In these

consequential forces resulting from plastic hinging shall then be used for determining design forces for most components as identified herein. The procedures for calculating these consequential forces for single column and pier supports and bents with two or more columns shall be taken as specified in the following Articles.

Inelastic hinges shall be ascertained to form before any other failure due to overstress or instability in the structure and/or in the foundation. Inelastic hinges shall only be permitted at locations in columns where they can be readily inspected and/or repaired. Inelastic flexural resistance of substructure components shall be determined in accordance with the provisions of Sections 5 and 6.

Superstructure and substructure components and their connections to columns shall also be designed to resist a lateral shear force from the column determined from the factored inelastic flexural resistance of the column using the resistance factors specified herein.

These consequential shear forces, calculated on the basis of inelastic hinging, may be taken as the extreme seismic forces that the bridge is capable of developing.

3.10.9.4.3b—Single Columns and Piers

Force effects shall be determined for the two principal axes of a column and in the weak direction of a pier or bent as follows:

- Step 1—Determine the column overstrength moment resistance. Use a resistance factor, ϕ of 1.3 for reinforced concrete columns and 1.25 for structural steel columns. For both materials, the applied axial load in the column shall be determined using Extreme Event Load Combination I, with the maximum elastic column axial load from the seismic forces determined in accordance with Article 3.10.8 taken as *EQ*.
- Step 2—Using the column overstrength moment resistance, calculate the corresponding column shear force. For flared columns, this calculation shall be performed using the overstrength resistances at both the top and bottom of the flare in conjunction with the appropriate column height. If the foundation of a column is significantly below ground level, consideration should be given to the possibility of the plastic hinge forming above the foundation. If this can occur, the column length between plastic hinges shall be used to calculate the column shear force.

Force effects corresponding to a single column hinging shall be taken as:

- Axial Forces—Those determined using Extreme Event Load Combination I, with the unreduced maximum and minimum seismic axial load of Article 3.10.8 taken as *EQ*.

circumstances, the use of a lower force, lower than that specified in Article 3.10.9.4.2, is justified and should result in a more economic foundation design.

See also Appendix B3.

C3.10.9.4.3b

The use of the factors 1.3 and 1.25 corresponds to the normal use of a resistance factor for reinforced concrete. In this case, it provides an increase in resistance, i.e., overstrength. Thus, the term “overstrength moment resistance” denotes a factor resistance in the parlance of these Specifications.

- Moments—Those calculated in Step 1.
- Shear Force—That calculated in Step 2.

3.10.9.4.3c—Piers with Two or More Columns

C3.10.9.4.3c

Force effects for bents with two or more columns shall be determined both in the plane of the bent and perpendicular to the plane of the bent. Perpendicular to the plane of the bent, the forces shall be determined as for single columns in Article 3.10.9.4.3b. In the plane of the bent, the forces shall be calculated as follows:

- Step 1—Determine the column overstrength moment resistances. Use a resistance factor, ϕ of 1.3 for reinforced concrete columns and 1.25 for structural steel columns. For both materials the initial axial load should be determined using the Extreme Event Load Combination I with $EQ = 0$.
- Step 2—Using the column overstrength moment resistance, calculate the corresponding column shear forces. Sum the column shears of the bent to determine the maximum shear force for the pier. If a partial-height wall exists between the columns, the effective column height should be taken from the top of the wall. For flared columns and foundations below ground level, the provisions of Article 3.10.9.4.3b shall apply. For pile bents, the length of pile above the mud line shall be used to calculate the shear force.
- Step 3—Apply the bent shear force to the center of mass of the superstructure above the pier and determine the axial forces in the columns due to overturning when the column overstrength moment resistances are developed.
- Step 4—Using these column axial forces as EQ in the Extreme Event Load Combination I, determine revised column overstrength moment resistance. With the revised overstrength moment resistances, calculate the column shear forces and the maximum shear force for the bent. If the maximum shear force for the bent is not within ten percent of the value previously determined, use this maximum bent shear force and return to Step 3.

See Article C3.10.9.4.3b.

The forces in the individual columns in the plane of a bent corresponding to column hinging shall be taken as:

- Axial Forces—The maximum and minimum axial loads determined using Extreme Event Load Combination I, with the axial load determined from the final iteration of Step 3 taken as EQ and treated as plus and minus.
- Moments—The column overstrength moment resistances corresponding to the maximum compressive axial load specified above.

- Shear Force—The shear force corresponding to the column overstrength moment resistances specified above, noting the provisions in Step 2 above.

3.10.9.4.3d— Column and Pile Bent Design Forces

Design forces for columns and pile bents shall be taken as a consistent set of the lesser of the forces determined as specified in Article 3.10.9.4.1, applied as follows:

- Axial Forces—The maximum and minimum design forces determined using Extreme Event Load Combination I with either the elastic design values determined in Article 3.10.8 taken as *EQ*, or the values corresponding to plastic hinging of the column taken as *EQ*.
- Moments—The modified design moments determined for Extreme Event Limit State Load Combination I.
- Shear Force—The lesser of either the elastic design value determined for Extreme Event Limit State Load Combination I with the seismic loads combined as specified in Article 3.10.8 and using an R-factor of 1 for the column, or the value corresponding to plastic hinging of the column.

3.10.9.4.3e—Pier Design Forces

The design forces shall be those determined for Extreme Event Limit State Load Combination I, except where the pier is designed as a column in its weak direction. If the pier is designed as a column, the design forces in the weak direction shall be as specified in Article 3.10.9.4.3d and all the design requirements for columns, as specified in Section 5, shall apply. When the forces due to plastic hinging are used in the weak direction, the combination of forces, specified in Article 3.10.8, shall be applied to determine the elastic moment which is then reduced by the appropriate R-factor.

3.10.9.4.3f—Foundation Design Forces

The design forces for foundations including footings, pile caps and piles may be taken as either those forces determined for the Extreme Event Load Combination I, with the seismic loads combined as specified in Article 3.10.8, or the forces at the bottom of the columns corresponding to column plastic hinging as determined in Article 3.10.8.

When the columns of a bent have a common footing, the final force distribution at the base of the columns in Step 4 of Article 3.10.9.4.3c may be used for the design of the footing in the plane of the bent. This force distribution produces lower shear forces and moments on the footing because one exterior column may be in tension and the other in compression due to the seismic overturning

C3.10.9.4.3d

The design axial forces which control both the flexural design of the column and the shear design requirements are either the maximum or minimum of the unreduced design forces or the values corresponding to plastic hinging of the columns. In most cases, the values of axial load and shear corresponding to plastic hinging of the columns will be lower than the unreduced design forces. The design shear forces are specified so that the possibility of a shear failure in the column is minimized.

When an inelastic hinging analysis is performed, these moments and shear forces are the maximum forces that can develop and, therefore, the directional load combinations of Article 3.10.8 do not apply.

C3.10.9.4.3e

The design forces for piers specified in Article 3.10.9.4.3e are based on the assumption that a pier has low ductility capacity and no redundancy. As a result, a low R-factor of 2 is used in determining the reduced design forces, and it is expected that only a small amount of inelastic deformation will occur in the response of a pier when subjected to the forces of the design earthquake. If a pier is designed as a column in its weak direction, then both the design forces and, more importantly, the design requirements of Articles 3.10.9.4.3d and Section 5 are applicable.

C3.10.9.4.3f

The foundation design forces specified are consistent with the design philosophy of minimizing damage that would not be readily detectable. The recommended design forces are the maximum forces that can be transmitted to the footing by plastic hinging of the column. The alternate design forces are the elastic design forces. It should be noted that these may be considerably greater than the recommended design forces, although where architectural considerations govern the design of a column, the alternate elastic design forces may be less than the forces resulting from column plastic hinging.

See also the second paragraph of C3.10.9.4.3d.

moment. This effectively increases the ultimate moments and shear forces on one column and reduces them on the other.

3.10.9.5—Longitudinal Restrainers

Friction shall not be considered to be an effective restrainer.

Restrainers shall be designed for a force calculated as the acceleration coefficient, A_S , as specified in Eq. 3.10.4.2-2, times the permanent load of the lighter of the two adjoining spans or parts of the structure.

If the restrainer is at a point where relative displacement of the sections of superstructure is designed to occur during seismic motions, sufficient slack shall be allowed in the restrainer so that the restrainer does not start to act until the design displacement is exceeded.

Where a restrainer is to be provided at columns or piers, the restrainer of each span may be attached to the column or pier rather than to interconnecting adjacent spans.

In lieu of restrainers, STUs may be used and designed for either the elastic force calculated in Article 4.7 or the maximum force effects generated by inelastic hinging of the substructure as specified in Article 3.10.7.1.

3.10.9.6—Hold-Down Devices

For Seismic Zones 2, 3, and 4, hold-down devices shall be provided at supports and at hinges in continuous structures where the vertical seismic force due to the longitudinal seismic load opposes and exceeds 50 percent, but is less than 100 percent, of the reaction due to permanent loads. In this case, the net uplift force for the design of the hold-down device shall be taken as ten percent of the reaction due to permanent loads that would be exerted if the span were simply supported.

If the vertical seismic forces result in net uplift, the hold-down device shall be designed to resist the larger of either:

- 120 percent of the difference between the vertical seismic force and the reaction due to permanent loads, or
- Ten percent of the reaction due to permanent loads.

3.10.10—Requirements for Temporary Bridges and Stage Construction

Any bridge or partially constructed bridge that is expected to be temporary for more than 5 yr shall be designed using the requirements for permanent structures and shall not use the provisions of this Article.

The requirement that an earthquake shall not cause collapse of all or part of a bridge, as stated in Article 3.10.1, shall apply to temporary bridges expected to carry traffic. It shall also apply to those bridges that are

C3.10.10

The option to use a reduced response coefficient and a reduced ground acceleration coefficient reflects the limited exposure period for a temporary bridge.

constructed in stages and expected to carry traffic and/or pass over routes that carry traffic. The elastic seismic response coefficient and the ground acceleration coefficient given in Article 3.10.4.2 may be reduced by a factor of not more than 2 in order to calculate the component elastic forces and displacements. Response and acceleration coefficients for construction sites that are close to active faults shall be the subject of special study. The response modification factors given in Article 3.10.7 may be increased by a factor of not more than 1.5 in order to calculate the design forces. This factor shall not be applied to connections as defined in Table 3.10.7.1-2.

The minimum support length provisions of Article 4.7.4.4 shall apply to all temporary bridges and staged construction.

3.11—EARTH PRESSURE: *EH, ES, LS, AND DD*

3.11.1—General

Earth pressure shall be considered as a function of the:

- Type and unit weight of earth,
- Water content,
- Soil creep characteristics,
- Degree of compaction,
- Location of groundwater table,
- Earth-structure interaction,
- Amount of surcharge,
- Earthquake effects,
- Back slope angle, and
- Wall inclination.

Silt and lean clay shall not be used for backfill unless suitable design procedures are followed and construction control measures are incorporated in the construction documents to account for their presence. Consideration shall be given for the development of pore water pressure within the soil mass in accordance with Article 3.11.3. Appropriate drainage provisions shall be provided to prevent hydrostatic and seepage forces from developing

C3.11.1

Walls that can tolerate little or no movement should be designed for at-rest earth pressure. Walls which can move away from the soil mass should be designed for pressures between active and at-rest conditions, depending on the magnitude of the tolerable movements. Movement required to reach the minimum active pressure or the maximum passive pressure is a function of the wall height and the soil type. Some typical values of these mobilizing movements, relative to wall height, are given in Table C3.11.1-1, where:

Δ = movement of top of wall required to reach minimum active or maximum passive pressure by tilting or lateral translation (ft)

H = height of wall (ft)

Table C3.11.1-1—Approximate Values of Relative Movements Required to Reach Active or Passive Earth Pressure Conditions (Clough and Duncan, 1991)

Type of Backfill	Values of Δ/H	
	Active	Passive
Dense sand	0.001	0.01
Medium dense sand	0.002	0.02
Loose sand	0.004	0.04
Compacted silt	0.002	0.02
Compacted lean clay	0.010	0.05
Compacted fat clay	0.010	0.05

The evaluation of the stress induced by cohesive soils is highly uncertain due to their sensitivity to shrink-swell, wet-dry and degree of saturation. Tension cracks can form, which considerably alter the assumptions for the estimation of stress. Extreme caution is advised in the determination of lateral earth pressures assuming the most unfavorable conditions. If possible, cohesive or other fine-grained soils should be avoided as backfill.

behind the wall in accordance with the provisions in Section 11. In no case shall highly plastic clay be used for backfill.

3.11.2—Compaction

Where activity by mechanical compaction equipment is anticipated within a distance of one-half the height of the wall, taken as the difference in elevation between the point where finished grade intersects the back of the wall and the base of the wall, the effect of additional earth pressure that may be induced by compaction shall be taken into account.

3.11.3—Presence of Water

If the retained earth is not allowed to drain, the effect of hydrostatic water pressure shall be added to that of earth pressure.

In cases where water is expected to pond behind a wall, the wall shall be designed to withstand the hydrostatic water pressure plus the earth pressure.

Submerged unit weights of the soil shall be used to determine the lateral earth pressure below the groundwater table.

For walls retaining cohesive materials, the effects of soil creep should be taken into consideration in estimating the design earth pressures. Evaluation of soil creep is complex and requires duplication in the laboratory of the stress conditions in the field as discussed by Mitchell (1976).

Under stress conditions close to the minimum active or maximum passive earth pressures, cohesive soils indicated in Table C3.11.1-1 creep continually, and the movements shown produce active or passive pressures only temporarily. If there is no further movement, active pressures will increase with time, approaching the at-rest pressure, and passive pressures will decrease with time, approaching values on the order of 40 percent of the maximum short-term value. A conservative assumption to account for unknowns would be to use the at-rest pressure based on the residual strength of the soil.

C3.11.2

Compaction-induced earth pressures may be estimated using the procedures described by Clough and Duncan (1991). The heavier the equipment used to compact the backfill, and the closer it operates to the wall, the larger are the compaction-induced pressures. The magnitude of the earth pressures exerted on a wall by compacted backfill can be minimized by using only small rollers or hand compactors within a distance of one-half wall height from the back of the wall. For MSE structures, compaction stresses are already included in the design model and specified compaction procedures.

C3.11.3

The effect of additional pressure caused by groundwater is shown in Figure C3.11.3-1.

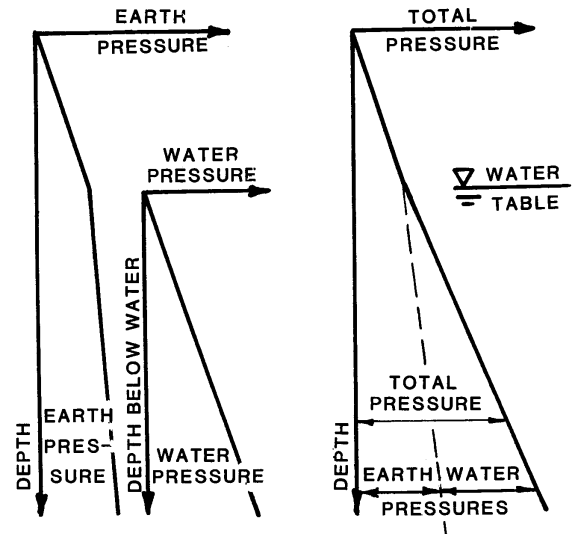

Figure C3.11.3-1—Effect of Groundwater Table

If the groundwater levels differ on opposite sides of the wall, the effects of seepage on wall stability and the potential for piping shall be considered. Pore water pressures shall be added to the effective horizontal stresses in determining total lateral earth pressures on the wall.

3.11.4—Effect of Earthquake

The effects of wall inertia and probable amplification of active earth pressure and/or mobilization of passive earth masses by earthquake shall be considered.

The development of hydrostatic water pressure on walls should be eliminated through use of crushed rock, pipe drains, gravel drains, perforated drains or geosynthetic drains.

Pore water pressures behind the wall may be approximated by flow net procedures or various analytical methods.

C3.11.4

The Mononobe-Okabe method for determining equivalent static fluid pressures for seismic loads on gravity and semigravity retaining walls is presented in the Appendix A11.

The Mononobe-Okabe analysis is based, in part, on the assumption that the backfill soils are unsaturated and thus, not susceptible to liquefaction.

Where soils are subject to both saturation and seismic or other cyclic/instantaneous loads, special consideration should be given to address the possibility of soil liquefaction.

3.11.5—Earth Pressure: *EH*

3.11.5.1—Lateral Earth Pressure

Lateral earth pressure shall be assumed to be linearly proportional to the depth of earth and taken as:

$$p = k\gamma_s z \quad (3.11.5.1-1)$$

where:

p = lateral earth pressure (ksf)

C3.11.5.1

- k = coefficient of lateral earth pressure taken as k_o , specified in Article 3.11.5.2, for walls that do not deflect or move, k_a , specified in Articles 3.11.5.3, 3.11.5.6 and 3.11.5.7, for walls that deflect or move sufficiently to reach minimum active conditions, or k_p , specified in Article 3.11.5.4, for walls that deflect or move sufficiently to reach a passive condition
- γ_s = unit weight of soil (kcf)
- z = depth below the surface of earth (ft)

The resultant lateral earth load due to the weight of the backfill shall be assumed to act at a height of $H/3$ above the base of the wall, where H is the total wall height, measured from the surface of the ground at the back of the wall to the bottom of the footing or the top of the leveling pad (for MSE walls).

Although previous versions of these Specifications have required design of conventional gravity walls for a resultant earth pressure located $0.4H$ above the wall base, the current specifications require design for a resultant located $H/3$ above the base. This requirement is consistent with historical practice and with calibrated resistance factors in Section 11. The resultant lateral load due to the earth pressure may act as high as $0.4H$ above the base of the wall for a mass concrete gravity retaining wall, where H is the total wall height measured from the top of the backfill to the base of the footing, where the wall deflects laterally, i.e., translates, in response to lateral earth loading. For such structures, the backfill behind the wall must slide down along the back of the wall for the retained soil mass to achieve the active state of stress. Experimental results indicate that the backfill arches against the upper portion of the wall as the wall translates, causing an upward shift in the location at which the resultant of the lateral earth load is transferred to the wall (Terzaghi, 1934; Clausen and Johansen et al., 1972; Sherif et al., 1982). Such walls are not representative of typical gravity walls used in highway applications.

For most gravity walls which are representative of those used in highway construction, nongravity cantilever retaining walls or other flexible walls which tilt or deform laterally in response to lateral loading, e.g., MSE walls, as well as walls which cannot translate or tilt, e.g., integral abutment walls, significant arching of the backfill against the wall does not occur, and the resultant lateral load due to earth pressure acts at a height of $H/3$ above the base of the wall. Furthermore, where wall friction is not considered in the analysis, it is sufficiently conservative to use a resultant location of $H/3$ even if the wall can translate.

3.11.5.2—At-Rest Lateral Earth Pressure Coefficient, k_o

For normally consolidated soils, vertical wall, and level ground, the coefficient of at-rest lateral earth pressure may be taken as:

$$k_o = 1 - \sin \phi'_f \quad (3.11.5.2-1)$$

where:

ϕ'_f = effective friction angle of soil

C3.11.5.2

For typical cantilevered walls over 5.0 ft high with structural grade backfill, calculations indicate that the horizontal movement of the top of the wall due to a combination of structural deformation of the stem and rotation of the foundation is sufficient to develop active conditions.

In many instances, the OCR may not be known with enough accuracy to calculate k_o using Eq. 3.11.5.2-2. Based on information on this issue provided by Holtz and

k_o = coefficient of at-rest lateral earth pressure

For overconsolidated soils, the coefficient of at-rest lateral earth pressure may be assumed to vary as a function of the overconsolidation ratio or stress history, and may be taken as:

$$k_o = (1 - \sin \phi'_f)(OCR)^{\sin \phi'_f} \quad (3.11.5.2-2)$$

where:

OCR = overconsolidation ratio

Silt and lean clay shall not be used for backfill unless suitable design procedures are followed and construction control measures are incorporated in the construction documents to account for their presence. Consideration must be given for the development of pore water pressure within the soil mass in accordance with Article 3.11.3. Appropriate drainage provisions shall be provided to prevent hydrostatic and seepage forces from developing behind the wall in accordance with the provisions of Section 11. In no case shall highly plastic clay be used for backfill.

3.11.5.3—Active Lateral Earth Pressure Coefficient, k_a

Values for the coefficient of active lateral earth pressure may be taken as:

$$k_a = \frac{\sin^2(\theta + \phi'_f)}{\Gamma [\sin^2 \theta \sin(\theta - \delta)]} \quad (3.11.5.3-1)$$

in which:

$$\Gamma = \left[1 + \sqrt{\frac{\sin(\phi'_f + \delta) \sin(\phi'_f - \beta)}{\sin(\theta - \delta) \sin(\theta + \beta)}} \right]^2 \quad (3.11.5.3-2)$$

where:

- δ = friction angle between fill and wall taken as specified in Table 3.11.5.3-1 (degrees)
- β = angle of fill to the horizontal as shown in Figure 3.11.5.3-1 (degrees)
- θ = angle of back face of wall to the horizontal as shown in Figure 3.11.5.3-1 (degrees)
- ϕ'_f = effective angle of internal friction (degrees)

For conditions that deviate from those described in Figure 3.11.5.3-1, the active pressure may be calculated by using a trial procedure based on wedge theory using the Culmann method (e.g., see Terzaghi et al., 1996).

Kovacs (1981), in general, for lightly overconsolidated sands ($OCR = 1$ to 2), k_o is in the range of 0.4 to 0.6 . For highly overconsolidated sand, k_o can be on the order of 1.0 .

The evaluation of the stress induced by cohesive soils is highly uncertain due to their sensitivity to shrink-swell, wet-dry and degree of saturation. Tension cracks can form, which considerably alter the assumptions for the estimation of stress. Extreme caution is advised in the determination of lateral earth pressures assuming the most unfavorable conditions. See Article C3.11.1 for additional guidance on estimating earth pressures in fine-grained soils. If possible, cohesive or other fine-grained soils should be avoided as backfill.

C3.11.5.3

The values of k_a by Eq. 3.11.5.3-1 are based on the Coulomb earth pressure theories. The Coulomb theory is necessary for design of retaining walls for which the back face of the wall interferes with the development of the full sliding surfaces in the backfill soil assumed in Rankine theory (Figure C3.11.5.3-1 and Article C3.11.5.8). Either Coulomb or Rankine wedge theory may be used for long heeled cantilever walls shown in Figure C3.11.5.3-1a. In general, Coulomb wedge theory applies for gravity, semigravity and prefabricated modular walls with relatively steep back faces, and concrete cantilever walls with short heels.

For the cantilever wall in Figure C3.11.5.3-1b, the earth pressure is applied to a plane extending vertically up from the heel of the wall base, and the weight of soil to the left of the vertical plane is considered as part of the wall weight.

The differences between the Coulomb theory currently specified, and the Rankine theory specified in the past is illustrated in Figure C3.11.5.3-1. The Rankine theory is the basis of the equivalent fluid method of Article 3.11.5.5.

Silt and lean clay should not be used for backfill where free-draining granular materials are available. When using poorly draining silts or cohesive soils, extreme caution is advised in the determination of lateral earth pressures assuming the most unfavorable conditions. Consideration must be given for the development of pore water pressure within the soil mass in accordance with Article 3.11.3. Appropriate drainage provisions should be provided to prevent hydrostatic and seepage forces from

developing behind the wall in accordance with the provisions in Section 11. In no case should highly plastic clay be used for backfill.

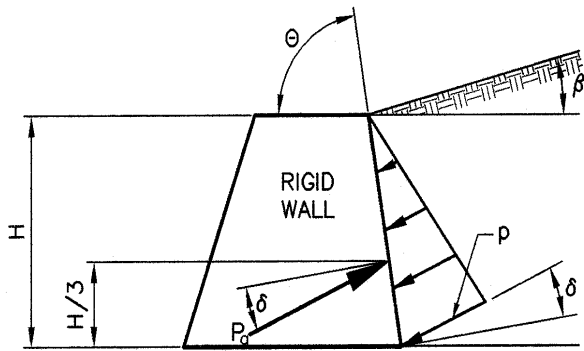

Figure 3.11.5.3-1—Notation for Coulomb Active Earth Pressure

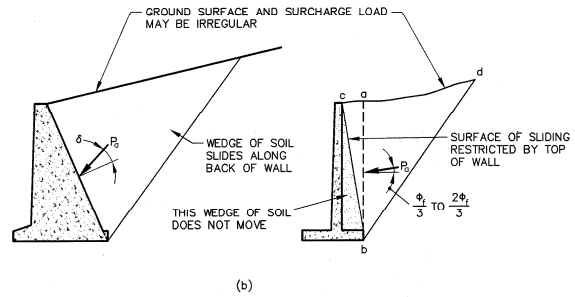
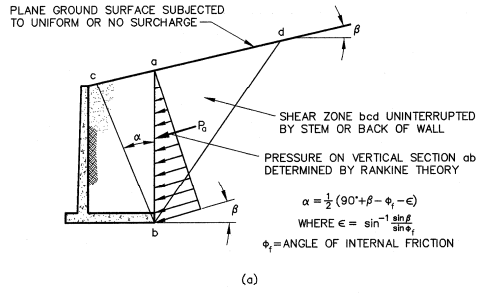

Figure C3.11.5.3-1—Application of (a) Rankine and (b) Coulomb Earth Pressure Theories in Retaining Wall Design

Table 3.11.5.3-1—Friction Angle for Dissimilar Materials (U.S. Department of the Navy, 1982a)

Interface Materials	Friction Angle, δ (degrees)	Coefficient of Friction, $\tan \delta$ (dim.)
Mass concrete on the following foundation materials:		
<ul style="list-style-type: none"> Clean sound rock Clean gravel, gravel-sand mixtures, coarse sand Clean fine to medium sand, silty medium to coarse sand, silty or clayey gravel Clean fine sand, silty or clayey fine to medium sand Fine sandy silt, nonplastic silt Very stiff and hard residual or preconsolidated clay Medium stiff and stiff clay and silty clay 	35 29 to 31 24 to 29 19 to 24 17 to 19 22 to 26 17 to 19	0.70 0.55 to 0.60 0.45 to 0.55 0.34 to 0.45 0.31 to 0.34 0.40 to 0.49 0.31 to 0.34
Masonry on foundation materials has same friction factors.		
Steel sheet piles against the following soils:		
<ul style="list-style-type: none"> Clean gravel, gravel-sand mixtures, well-graded rock fill with spalls Clean sand, silty sand-gravel mixture, single-size hard rock fill Silty sand, gravel or sand mixed with silt or clay Fine sandy silt, nonplastic silt 	22 17 14 11	0.40 0.31 0.25 0.19
Formed or precast concrete or concrete sheet piling against the following soils:		
<ul style="list-style-type: none"> Clean gravel, gravel-sand mixture, well-graded rock fill with spalls Clean sand, silty sand-gravel mixture, single-size hard rock fill Silty sand, gravel or sand mixed with silt or clay Fine sandy silt, nonplastic silt 	22 to 26 17 to 22 17 14	0.40 to 0.49 0.31 to 0.40 0.31 0.25
Various structural materials:		
<ul style="list-style-type: none"> Masonry on masonry, igneous and metamorphic rocks: <ul style="list-style-type: none"> dressed soft rock on dressed soft rock dressed hard rock on dressed soft rock dressed hard rock on dressed hard rock Masonry on wood in direction of cross grain Steel on steel at sheet pile interlocks 	35 33 29 26 17	0.70 0.65 0.55 0.49 0.31

3.11.5.4—Passive Lateral Earth Pressure Coefficient, k_p

For noncohesive soils, values of the coefficient of passive lateral earth pressure may be taken from Figure 3.11.5.4-1 for the case of a sloping or vertical wall with a horizontal backfill or from Figure 3.11.5.4-2 for the case of a vertical wall and sloping backfill. For conditions that deviate from those described in Figures 3.11.5.4-1 and 3.11.5.4-2, the passive pressure may be calculated by using a trial procedure based on wedge theory, e.g., see Terzaghi et al. (1996). When wedge theory is used, the limiting value of the wall friction angle should not be taken larger than one-half the angle of internal friction, ϕ_r .

For cohesive soils, passive pressures may be estimated by:

C3.11.5.4

The movement required to mobilize passive pressure is approximately 10.0 times as large as the movement needed to induce earth pressure to the active values. The movement required to mobilize full passive pressure in loose sand is approximately five percent of the height of the face on which the passive pressure acts. For dense sand, the movement required to mobilize full passive pressure is smaller than five percent of the height of the face on which the passive pressure acts, and five percent represents a conservative estimate of the movement required to mobilize the full passive pressure. For poorly compacted cohesive soils, the movement required to mobilize full passive pressure is larger than five percent of the height of the face on which the pressure acts.

$$p_p = k_p \gamma_s z + 2c \sqrt{k_p} \quad (3.11.5.4-1)$$

Wedge solutions are inaccurate and unconservative for larger values of wall friction angle.

where:

- p_p = passive lateral earth pressure (ksf)
- γ_s = unit weight of soil (kcf)
- z = depth below surface of soil (ft)
- c = soil cohesion (ksf)
- k_p = coefficient of passive lateral earth pressure specified in Figures 3.11.5.4-1 and 3.11.5.4-2, as appropriate

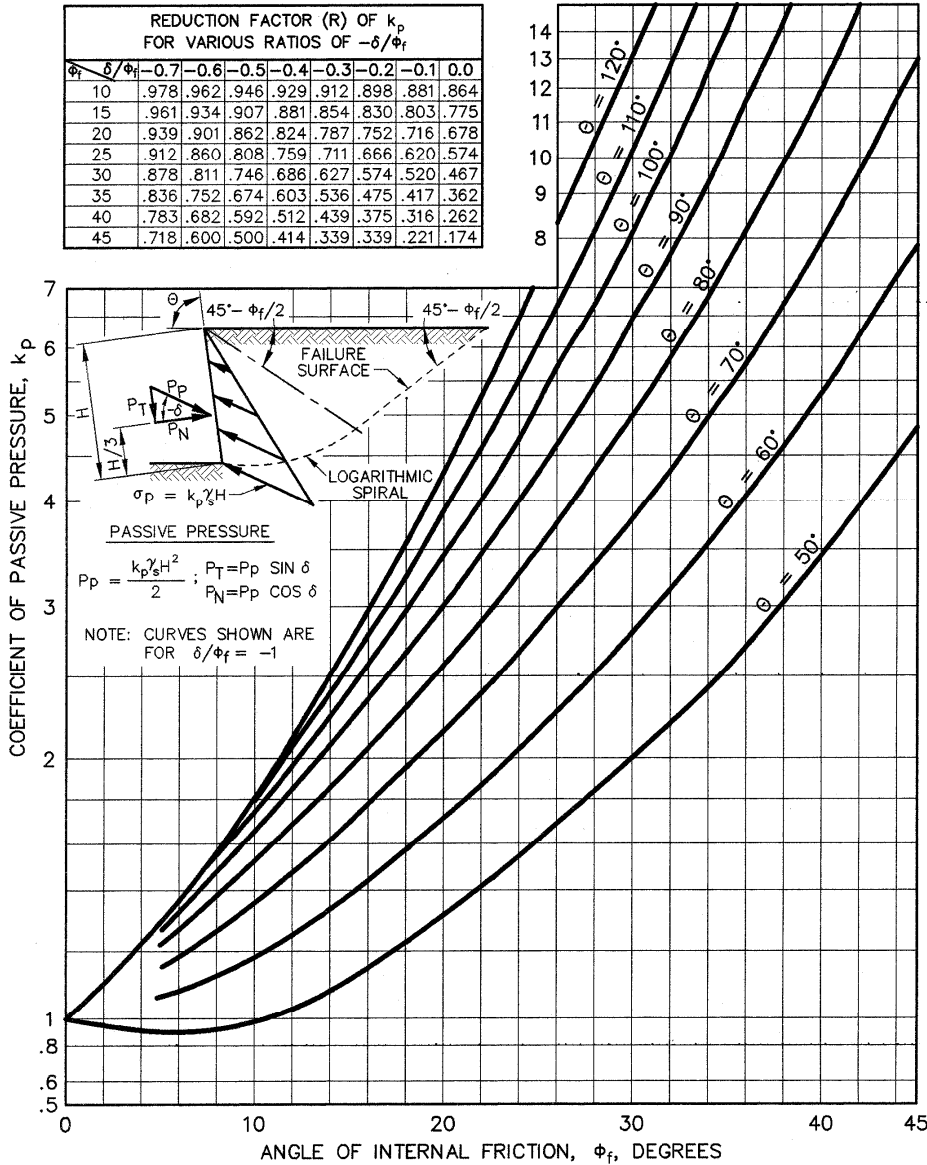

Figure 3.11.5.4-1—Computational Procedures for Passive Earth Pressures for Vertical and Sloping Walls with Horizontal Backfill (U.S. Department of the Navy, 1982a)

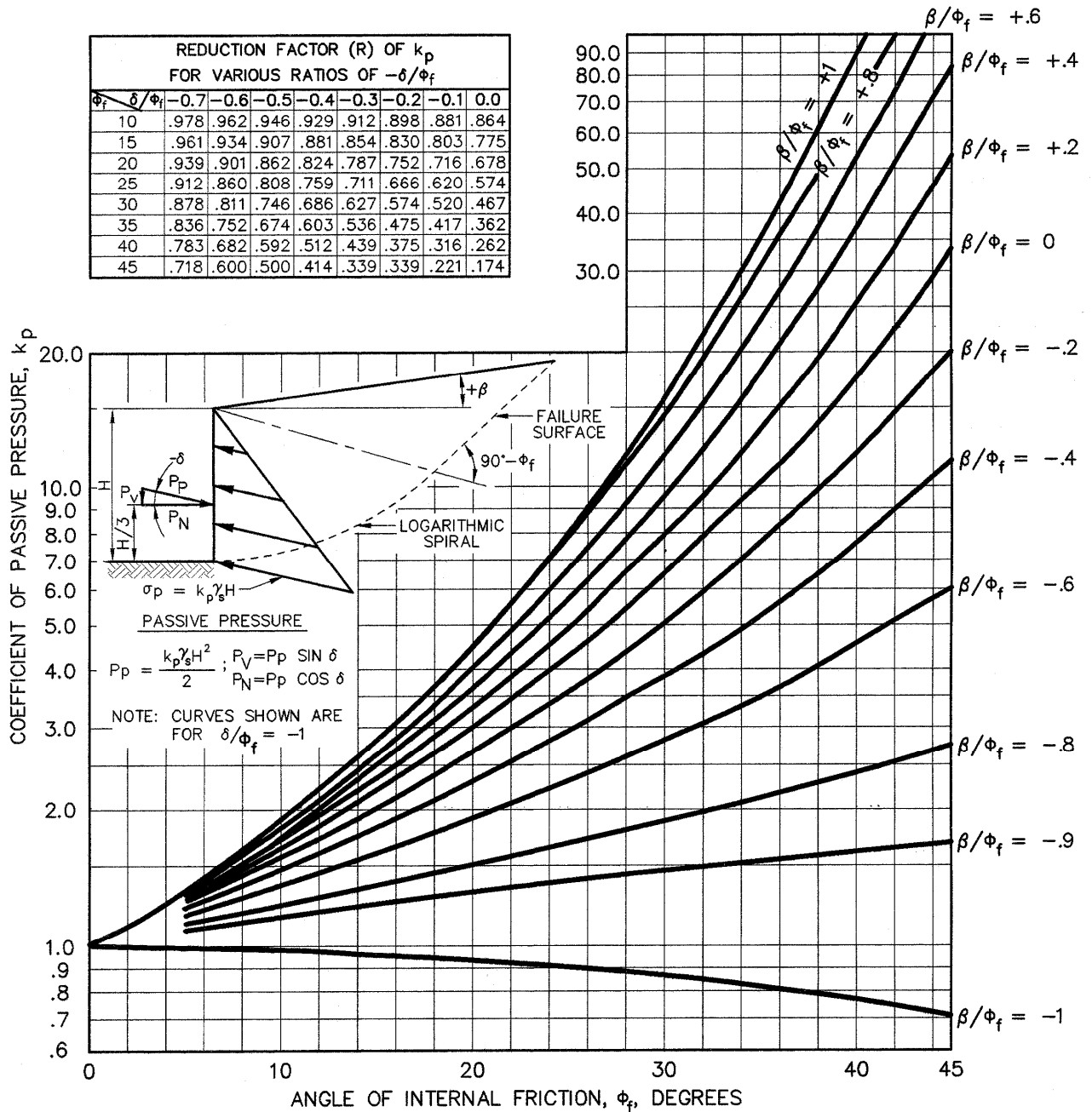

Figure 3.11.5.4-2—Computational Procedures for Passive Earth Pressures for Vertical Wall with Sloping Backfill (U.S. Department of the Navy, 1982a)

3.11.5.5—Equivalent-Fluid Method of Estimating Rankine Lateral Earth Pressures

C3.11.5.5

The equivalent-fluid method may be used where Rankine earth pressure theory is applicable.

Applicability of Rankine theory is discussed in **Article C3.11.5.3**.

The equivalent-fluid method shall only be used where the backfill is free-draining. If this criterion cannot be satisfied, the provisions of Articles 3.11.3, 3.11.5.1 and 3.11.5.3 shall be used to determine horizontal earth pressure.

Values of the unit weights of equivalent fluids are given for walls that can tolerate very little or no movement as well as for walls that can move as much as 1.0 in. in 20.0 ft. The concepts of equivalent fluid unit weights have taken into account the effect of soil creep on walls.

Where the equivalent-fluid method is used, the basic earth pressure, p (ksf), may be taken as:

$$p = \gamma_{eq} z \tag{3.11.5.5-1}$$

where:

- γ_{eq} = equivalent fluid unit weight of soil, not less than 0.030 (kcf)
- z = depth below surface of soil (ft)

The resultant lateral earth load due to the weight of the backfill shall be assumed to act at a height of $H/3$ above the base of the wall, where H is the total wall height, measured from the surface of the ground to the bottom of the footing.

Typical values for equivalent fluid unit weights for design of a wall of height not exceeding 20.0 ft may be taken from Table 3.11.5.5-1, where:

- Δ = movement of top of wall required to reach minimum active or maximum passive pressure by tilting or lateral translation (ft)
- H = height of wall (ft)
- β = angle of fill to the horizontal (degrees)

The magnitude of the vertical component of the earth pressure resultant for the case of sloping backfill surface may be determined as:

$$P_v = P_h \tan \beta \tag{3.11.5.5-2}$$

where:

$$P_h = 0.5\gamma_{eq} H^2 \tag{3.11.5.5-3}$$

If the backfill qualifies as free-draining (i.e., granular material with <5 percent passing a No. 200 sieve), water is prevented from creating hydrostatic pressure.

For discussion on the location of the resultant of the lateral earth force see Article C3.11.5.1.

The values of equivalent fluid unit weight presented in Table 3.11.5.5-1 for $\Delta/H = 1/240$ represent the horizontal component of active earth pressure based on Rankine earth pressure theory. This horizontal earth pressure is applicable for cantilever retaining walls for which the wall stem does not interfere with the sliding surface defining the Rankine failure wedge within the wall backfill (Figure C3.11.5.3-1). The horizontal pressure is applied to a vertical plane extending up from the heel of the wall base, and the weight of soil to the left of the vertical plane is included as part of the wall weight.

For the case of a sloping backfill surface in Table 3.11.5.5-1, a vertical component of earth pressure also acts on the vertical plane extending up from the heel of the wall.

Table 3.11.5.5-1—Typical Values for Equivalent Fluid Unit Weights of Soils

Type of Soil	Level Backfill		Backfill with $\beta = 25$ degrees	
	At-Rest γ_{eq} (kcf)	Active $\Delta/H = 1/240$ γ_{eq} (kcf)	At-Rest γ_{eq} (kcf)	Active $\Delta/H = 1/240$ γ_{eq} (kcf)
Loose sand or gravel	0.055	0.040	0.065	0.050
Medium dense sand or gravel	0.050	0.035	0.060	0.045
Dense sand or gravel	0.045	0.030	0.055	0.040

3.11.5.6—Lateral Earth Pressures for Nongravity Cantilevered Walls

For permanent walls, the simplified lateral earth pressure distributions shown in Figures 3.11.5.6-1 through 3.11.5.6-3 may be used. If walls will support or are supported by cohesive soils for temporary applications, walls may be designed based on total stress methods of analysis and undrained shear strength parameters. For this latter case, the simplified earth pressure distributions shown in Figures 3.11.5.6-4 through 3.11.5.6-7 may be used with the following restrictions:

- The ratio of total overburden pressure to undrained shear strength, N_s (see Article 3.11.5.7.2), should be < 3 at the wall base.
- The active earth pressure shall not be less than 0.25 times the effective overburden pressure at any depth, or 0.035 ksf/ft of wall height, whichever is greater.

For temporary walls with discrete vertical elements embedded in granular soil or rock, Figures 3.11.5.6-1 and 3.11.5.6-2 may be used to determine passive resistance and Figures 3.11.5.6-4 and 3.11.5.6-5 may be used to determine the active earth pressure due to the retained soil.

Where discrete vertical wall elements are used for support, the width, b , of each vertical element shall be assumed to equal the width of the flange or diameter of the element for driven sections and the diameter of the concrete-filled hole for sections encased in concrete.

The magnitude of the sloping surcharge above the wall for the determination of P_{a2} in Figure 3.11.5.6-4 should be based on the wedge of soil above the wall within the active wedge.

In Figure 3.11.5.6-5, a portion of negative loading at top of wall due to cohesion is ignored and hydrostatic pressure in a tension crack should be considered, but is not shown on the figure.

C3.11.5.6

Nongravity cantilevered walls temporarily supporting or supported by cohesive soils are subject to excessive lateral deformation if the undrained soil shear strength is low compared to the shear stresses. Therefore, use of these walls should be limited to soils of adequate strength as represented by the stability number N_s (see Article 3.11.5.7.2).

Base movements in the soil in front of a wall become significant for values of N_s of about 3 to 4, and a base failure can occur when N_s exceeds about 5 to 6 (Terzaghi and Peck, 1967).

In Figures 3.11.5.6-1, 3.11.5.6-2, 3.11.5.6-4, and 3.11.5.6-5, the width b of discrete vertical wall elements effective in mobilizing the passive resistance of the soil is based on a method of analysis by Broms (1964a, 1964b) for single vertical piles embedded in cohesive or cohesionless soil and assumes a vertical element. The effective width for passive resistance of three times the element width, $3b$, is due to the arching action in soil and side shear on resisting rock wedges. The maximum width of $3b$ can be used when material in which the vertical element is embedded does not contain discontinuities that would affect the failure geometry. This width should be reduced if planes or zones of weakness would prevent mobilization of resistance through this entire width, or if the passive resistance zones of adjacent elements overlap. If the element is embedded in soft clay having a stability number less than three, soil arching will not occur and the actual width shall be used as the effective width for passive resistance. Where a vertical element is embedded in rock, i.e., Figure 3.11.5.6-2, the passive resistance of the rock is assumed to develop through the shear failure of a rock wedge equal in width to the vertical element, b , and defined by a plane extending upward from the base of the element at an angle of 45 degrees. For the active zone behind the wall below the mudline or groundline in front of the wall, the active pressure is assumed to act over one vertical element width, b , in all cases.

The design grade is generally taken below finished grade to account for excavation during or after wall construction or other disturbance to the supporting soil during the service life of the wall.

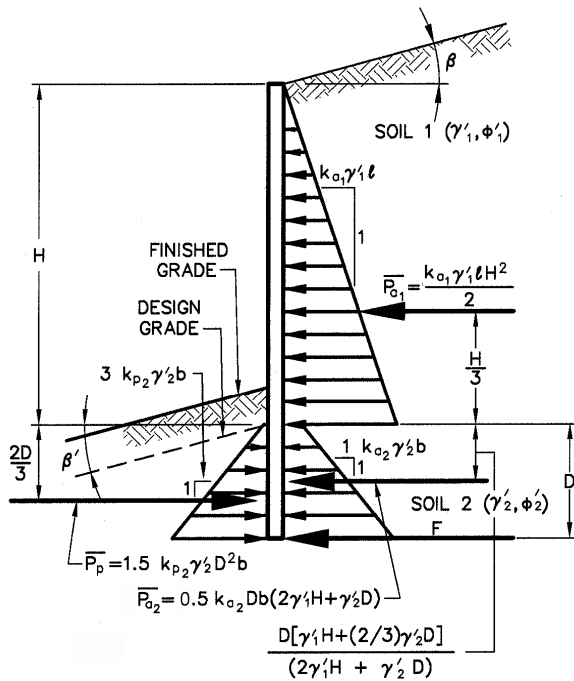

b = ACTUAL WIDTH OF EMBEDDED DISCRETE VERTICAL WALL ELEMENT BELOW DESIGN GRADE IN PLANE OF WALL (FT.).

Figure 3.11.5.6-1—Unfactored Simplified Earth Pressure Distributions for Permanent Nongravity Cantilevered Walls with Discrete Vertical Wall Elements Embedded in Granular Soil

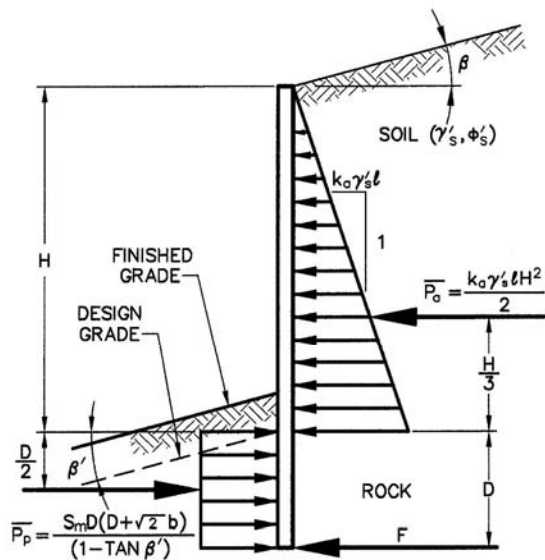

b = ACTUAL WIDTH OF EMBEDDED DISCRETE VERTICAL WALL ELEMENT BELOW DESIGN GRADE IN PLANE OF WALL (FT.).

Figure 3.11.5.6-2—Unfactored Simplified Earth Pressure Distributions for Permanent Nongravity Cantilevered Walls with Discrete Vertical Wall Elements Embedded in Rock

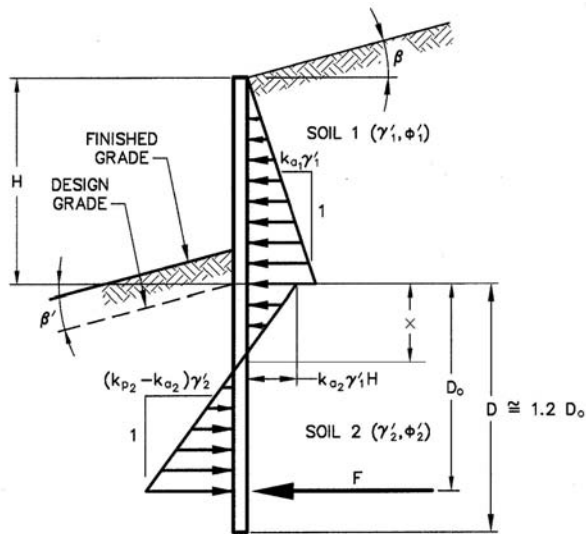
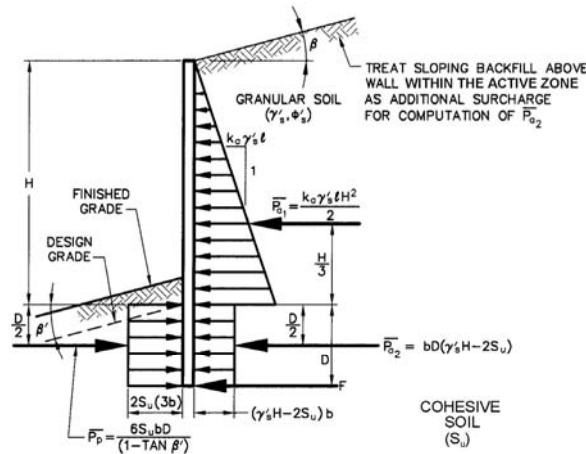
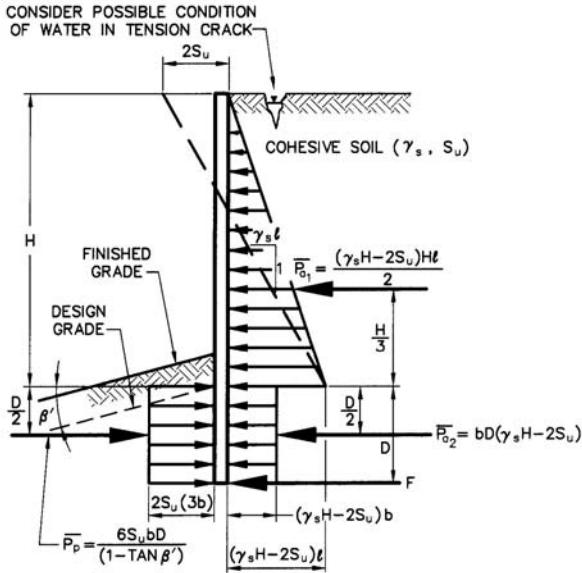

Figure 3.11.5.6-3—Unfactored Simplified Earth Pressure Distributions for Permanent Nongravity Cantilevered Walls with Continuous Vertical Wall Elements Embedded in Granular Soil Modified after Teng (1962)



b = ACTUAL WIDTH OF EMBEDDED DISCRETE VERTICAL WALL ELEMENT BELOW DESIGN GRADE IN PLANE OF WALL (FT.).

Figure 3.11.5.6-4—Unfactored Simplified Earth Pressure Distributions for Temporary Nongravity Cantilevered Walls with Discrete Vertical Wall Elements Embedded in Cohesive Soil and Retaining Granular Soil



b = ACTUAL WIDTH OF EMBEDDED DISCRETE VERTICAL WALL ELEMENT BELOW DESIGN GRADE IN PLANE OF WALL (FT.).

Figure 3.11.5.6-5—Unfactored Simplified Earth Pressure Distributions for Temporary Nongravity Cantilevered Walls with Discrete Vertical Wall Elements Embedded in Cohesive Soil and Retaining Cohesive Soil

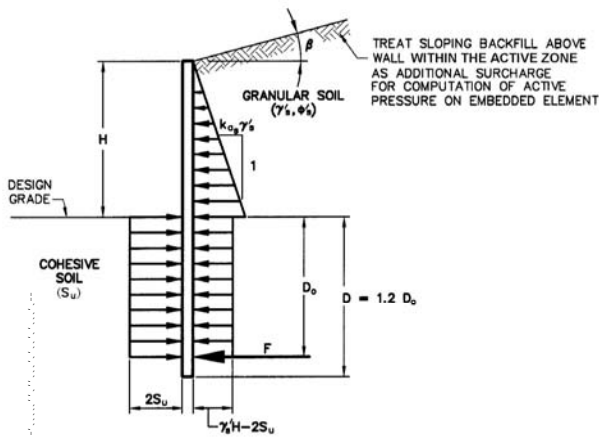

Note: For walls embedded in granular soil, refer to Figure 3.11.5.6.3-3 and use Figure 3.11.5.6-7 for retained cohesive soil when appropriate.

Figure 3.11.5.6-6—Unfactored Simplified Earth Pressure Distributions for Temporary Nongravity Cantilevered Walls with Continuous Vertical Wall Elements Embedded in Cohesive Soil and Retaining Granular Soil Modified after Teng (1962)

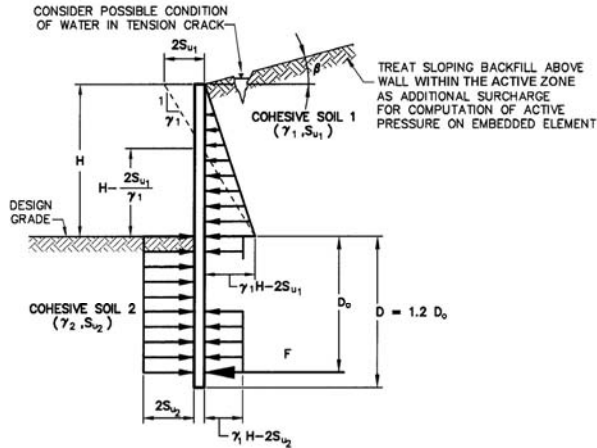

Figure 3.11.5.6-7—Unfactored Simplified Earth Pressure Distributions for Temporary Nongravity Cantilevered Walls with Continuous Vertical Wall Elements Embedded in Cohesive Soil and Retaining Cohesive Soil Modified after Teng (1962)

3.11.5.7—Apparent Earth Pressure (*AEP*) for Anchored Walls

For anchored walls constructed from the top down, the earth pressure may be estimated in accordance with Articles 3.11.5.7.1 or 3.11.5.7.2.

In developing the design pressure for an anchored wall, consideration shall be given to wall displacements that may affect adjacent structures and/or underground utilities.

C3.11.5.7

In the development of lateral earth pressures, the method and sequence of construction, the rigidity of the wall/anchor system, the physical characteristics and stability of the ground mass to be supported, allowable wall deflections, anchor spacing and prestress and the potential for anchor yield should be considered.

Several suitable apparent earth pressure distribution diagrams are available and in common use for the design of anchored walls, Sabatini et al. (1999); Cheney (1988); and U. S. Department of the Navy (1982a). Some of the apparent earth pressure diagrams, such as those described in Articles 3.11.5.7.1 and 3.11.5.7.2, are based on the results of measurements on anchored walls, Sabatini et al. (1999). Others are based on the results of measurements on strutted excavations, Terzaghi and Peck (1967), the results of analytical and scale model studies, Clough and Tsui (1974); Hanna and Matallana (1970), and observations of anchored wall installations (Nicholson et al., 1981); Schnabel (1982). While the results of these efforts provide somewhat different and occasionally conflicting results, they all tend to confirm the presence of higher lateral pressures near the top of the wall than would be predicted by classical earth pressure theories, due to the constraint provided by the upper level of anchors, and a generally uniform pressure distribution with depth.

3.11.5.7.1—Cohesionless Soils

The earth pressure on temporary or permanent anchored walls constructed in cohesionless soils may be determined using Figure 3.11.5.7.1-1, for which the maximum ordinate, p_a , of the pressure diagram is computed as follows:

For walls with one anchor level:

$$p_a = k_a \gamma'_s H \tag{3.11.5.7.1-1}$$

For walls with multiple anchor levels:

$$p_a = \frac{k_a \gamma'_s H^2}{1.5H - 0.5H_1 - 0.5H_{n+1}} \tag{3.11.5.7.1-2}$$

where:

- p_a = maximum ordinate of pressure diagram (ksf)
- k_a = active earth pressure coefficient
= $\tan^2 (45 \text{ degrees} - \phi_f/2)$ (dim.) for $\beta = 0$
use Eq. 3.11.5.3-1 for $\beta \neq 0$
- γ'_s = effective unit weight of soil (kcf)
- H = total excavation depth (ft)
- H_1 = distance from ground surface to uppermost ground anchor (ft)
- H_{n+1} = distance from base of excavation to lowermost ground anchor (ft)
- T_{hi} = horizontal load in ground anchor i (kip/ft)
- R = reaction force to be resisted by subgrade (i.e., below base of excavation) (kip/ft)

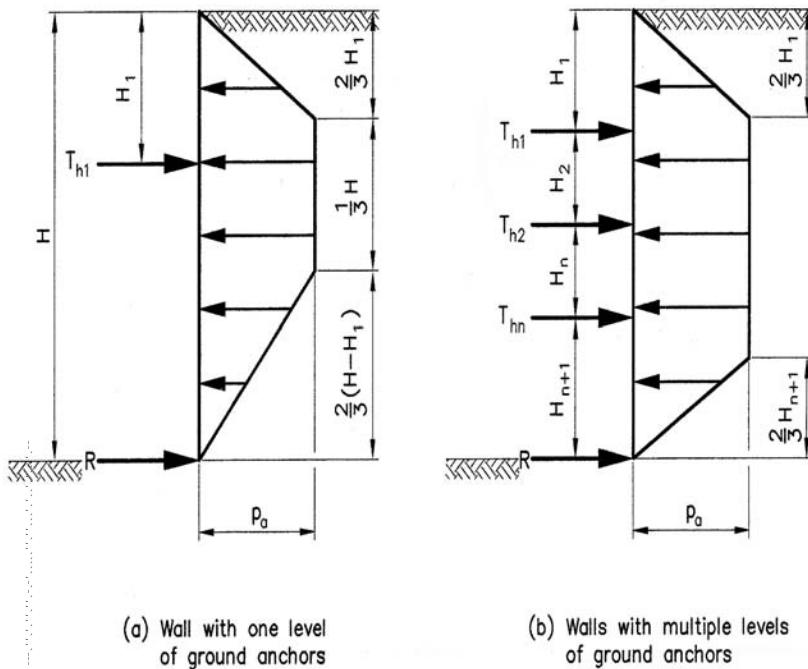

Figure 3.11.5.7.1-1—Apparent Earth Pressure Distributions for Anchored Walls Constructed from the Top Down in Cohesionless Soils

3.11.5.7.2—Cohesive Soils

The apparent earth pressure distribution for cohesive soils is related to the stability number, N_s , which is defined as:

$$N_s = \frac{\gamma_s H}{S_u} \quad (3.11.5.7.2-1)$$

where:

- γ_s = total unit weight of soil (kcf)
 H = total excavation depth (ft)
 S_u = average undrained shear strength of soil (ksf)

3.11.5.7.2a—Stiff to Hard

For temporary anchored walls in stiff to hard cohesive soils ($N_s \leq 4$), the earth pressure may be determined using Figure 3.11.5.7.1-1, with the maximum ordinate, p_a , of the pressure diagram computed as:

$$p_a = 0.2\gamma_s H \text{ to } 0.4\gamma_s H \quad (3.11.5.7.2a-1)$$

where:

- p_a = maximum ordinate of pressure diagram (ksf)
 γ_s = total unit weight of soil (kcf)
 H = total excavation depth (ft)

For permanent anchored walls in stiff to hard cohesive soils, the apparent earth pressure distributions described in Article 3.11.5.7.1 may be used with k_a based on the drained friction angle of the cohesive soil. For permanent walls, the distribution, permanent or temporary, resulting in the maximum total force shall be used for design.

3.11.5.7.2b—Soft to Medium Stiff

The earth pressure on temporary or permanent walls in soft to medium stiff cohesive soils ($N_s \geq 6$) may be determined using Figure 3.11.5.7.2b-1, for which the maximum ordinate, p_a , of the pressure diagram is computed as:

$$p_a = k_a \gamma_s H \quad (3.11.5.7.2b-1)$$

where:

- p_a = maximum ordinate of pressure diagram (ksf)
 k_a = active earth pressure coefficient from Eq. 3.11.5.7.2b-2
 γ_s = total unit weight of soil (kcf)
 H = total excavation depth (ft)

The active earth pressure coefficient, k_a , may be determined by:

$$k_a = 1 - \frac{4S_u}{\gamma_s H} + 2\sqrt{2} \frac{d}{H} \left(\frac{1 - 5.14S_{ub}}{\gamma_s H} \right) \geq 0.22 \quad (3.11.5.7.2b-2)$$

C3.11.5.7.2a

The determination of earth pressures in cohesive soils described in this Article and Article 3.11.5.7.2b are based on the results of measurements on anchored walls, Sabatini et al. (1999). In the absence of specific experience in a particular deposit, $p_a = 0.3 \gamma_s H$ should be used for the maximum pressure ordinate when ground anchors are locked off at 75 percent of the unfactored design load or less. Where anchors are to be locked off at 100 percent of the unfactored design load or greater, a maximum pressure ordinate of $p_a = 0.4 \gamma_s H$ should be used.

For temporary walls, the apparent earth pressure distribution in Figure 3.11.5.7.1-1 should only be used for excavations of controlled short duration, where the soil is not fissured and where there is no available free water.

Temporary loading may control design of permanent walls and should be evaluated in addition to permanent loading.

C3.11.5.7.2b

For soils with $4 < N_s < 6$, use the larger p_a from Eq. 3.11.5.7.2a-1 and Eq. 3.11.5.7.2b-1.

where:

- S_u = undrained strength of retained soil (ksf)
- S_{ub} = undrained strength of soil below excavation base (ksf)
- γ_s = total unit weight of retained soil (kcf)
- H = total excavation depth (ft)
- d = depth of potential base failure surface below base of excavation (ft)

The value of d is taken as the thickness of soft to medium stiff cohesive soil below the excavation base up to a maximum value of $B_e/\sqrt{2}$, where B_e is the excavation width.

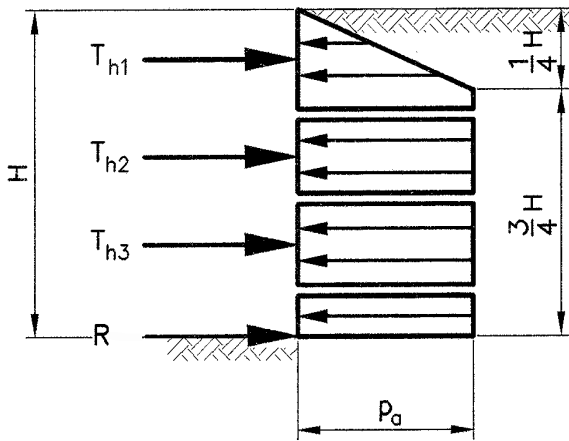

Figure 3.11.5.7.2b-1—Apparent Earth Pressure Distribution for Anchored Walls Constructed from the Top Down in Soft to Medium Stiff Cohesive Soils

3.11.5.8—Lateral Earth Pressures for Mechanically Stabilized Earth Walls

3.11.5.8.1—General

The resultant force per unit width behind an MSE wall, shown in Figures 3.11.5.8.1-1, 3.11.5.8.1-2, and 3.11.5.8.1-3 as acting at a height of $h/3$ above the base of the wall, shall be taken as:

$$P_a = 0.5k_a\gamma_s h^2 \tag{3.11.5.8.1-1}$$

where:

- P_a = force resultant per unit width (kip/ft)
- γ_s = total unit weight of backfill (kcf)
- h = height of horizontal earth pressure diagram taken as shown in Figures 3.11.5.8.1-1, 3.11.5.8.1-2, and 3.11.5.8.1-3 (ft)
- k_a = active earth pressure coefficient specified in Article 3.11.5.3, with the angle of backfill slope taken as β , as specified in Figure 3.11.5.8.1-2; B , as specified in Figure 3.11.5.8.1-3; and $\delta = \beta$ and B in Figures 3.11.5.8.1-2 and 3.11.5.8.1-3, respectively.

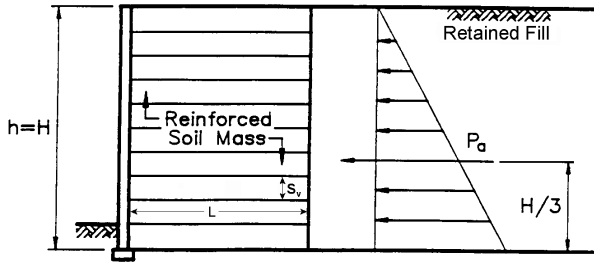

Figure 3.11.5.8.1-1—Earth Pressure Distribution for MSE Wall with Level Backfill Surface

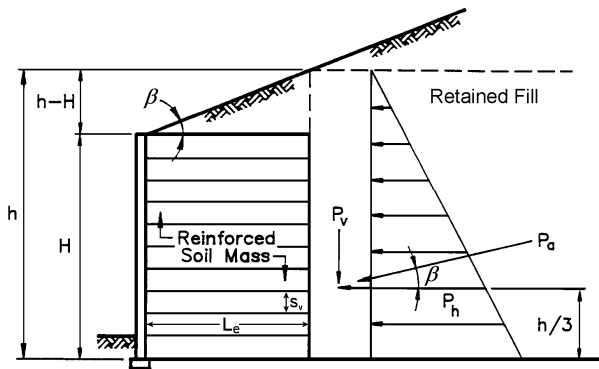

Figure 3.11.5.8.1-2—Earth Pressure for MSE Wall with Sloping Backfill Surface

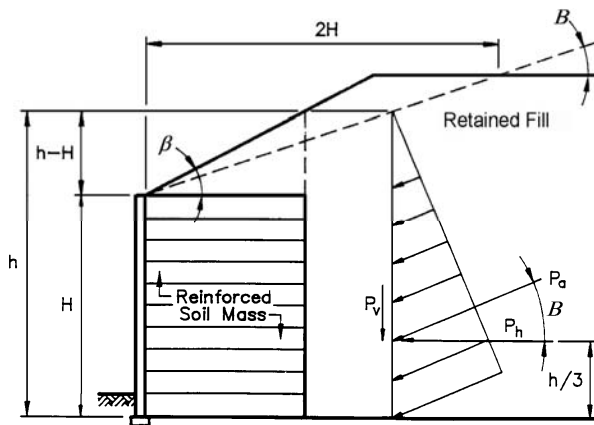

Figure 3.11.5.8.1-3—Earth Pressure Distribution for MSE Wall with Broken Back Backfill Surface

3.11.5.8.2—Internal Stability

The load factor γ_p to be applied to the maximum load carried by the reinforcement T_{max} for reinforcement strength, connection strength, and pullout calculations (see Article 11.10.6.2) shall be EV , for vertical earth pressure.

For MSE walls, η_i shall be taken as 1.

3.11.5.9—Lateral Earth Pressures for Prefabricated Modular Walls

The magnitude and location of resultant loads and resisting forces for prefabricated modular walls may be determined using the earth pressure distributions presented in Figures 3.11.5.9-1 and 3.11.5.9-2. Where the back of the prefabricated modules forms an irregular, stepped surface, the earth pressure shall be computed on a plane surface drawn from the upper back corner of the top module to the lower back heel of the bottom module using Coulomb earth pressure theory.

C3.11.5.8.2

Loads carried by the soil reinforcement in mechanically stabilized earth walls are the result of vertical and lateral earth pressures which exist within the reinforced soil mass, reinforcement extensibility, facing stiffness, wall toe restraint, and the stiffness and strength of the soil backfill within the reinforced soil mass. The calculation method for T_{max} is empirically derived, based on reinforcement strain measurements, converted to load based on the reinforcement modulus, from full scale walls at working stress conditions. The load factor EV , on the other hand, was determined in consideration of vertical earth pressure exerted by a soil mass without inclusions, and was calibrated to address uncertainties implied by allowable stress design for external stability for walls. EV is not directly applicable to internal reinforcement loads in MSE walls, since the calibration of EV was not performed with internal stability of a reinforced system in mind.

The use of EV for the load factor in this case should be considered an interim measure until research is completed to quantify load prediction bias and uncertainty.

C3.11.5.9

Prefabricated modular walls are gravity walls constructed of prefabricated concrete elements that are in-filled with soil. They differ from modular block MSE structures in that they contain no soil reinforcing elements.

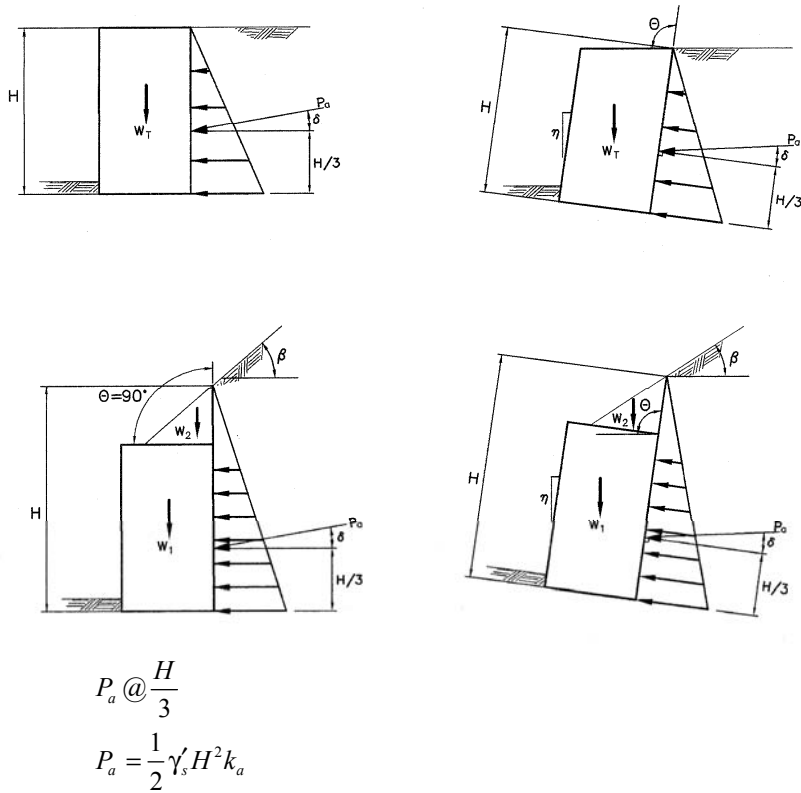

Figure 3.11.5.9-1—Earth Pressure Distributions for Prefabricated Modular Walls with Continuous Pressure Surfaces

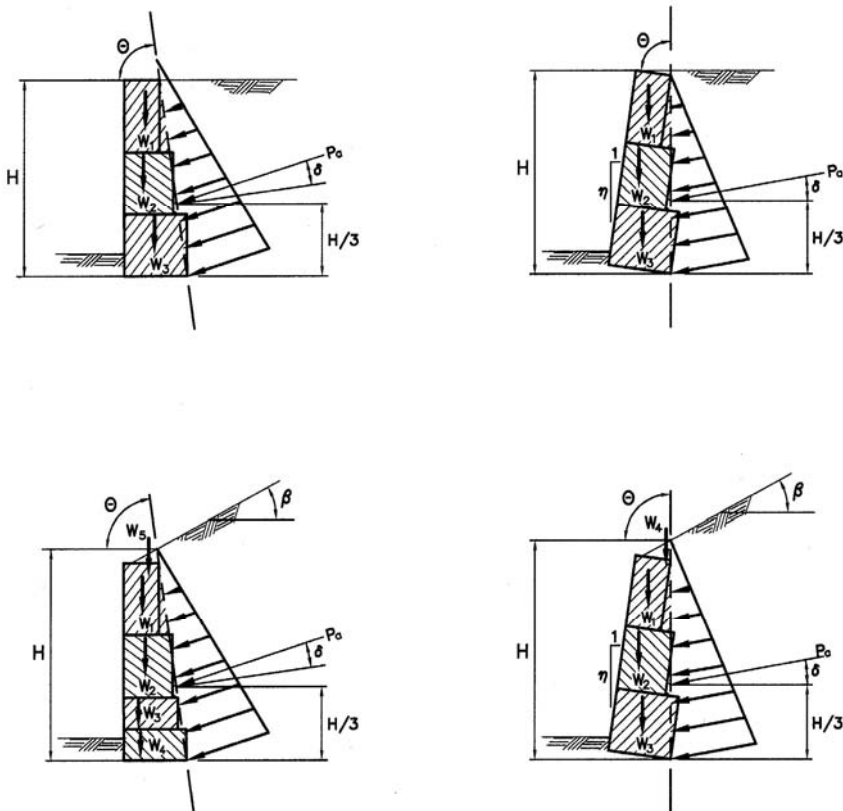

Figure 3.11.5.9-2—Earth Pressure Distributions for Prefabricated Modular Walls with Irregular Pressure Surfaces

The value of k_a used to compute lateral thrust resulting from retained backfill and other loads behind the wall shall be computed based on the friction angle of the backfill behind the modules. In the absence of specific data, if granular backfill is used behind the prefabricated modules within a zone of at least 1V:1H from the heel of the wall, a value of 34 degrees may be used for ϕ_f . Otherwise, without specific data, a maximum friction angle of 30 degrees shall be used.

The wall friction angle, δ , is a function of the direction and magnitude of possible movements, and the properties of the backfill. When the structure settles more than the backfill, the wall friction angle is negative.

As a maximum, the wall friction angles, given in Table C3.11.5.9-1, should be used to compute k_a , unless more exact coefficients are demonstrated:

Table C3.11.5.9-1—Maximum Wall Friction Angles, δ

Case	Wall Friction Angle (δ)
Modules settle more than backfill	0
Continuous pressure surface of precast concrete (uniform width modules)	$0.50 \phi_f$
Average pressure surface (stepped modules)	$0.75 \phi_f$

3.11.5.10—Lateral Earth Pressures for Sound Barriers Supported on Discrete and Continuous Vertical Embedded Elements

For sound barriers supported on discrete vertical wall elements embedded in granular soil, rock, or cohesive soil, the simplified lateral earth pressure distributions shown in Figures 3.11.5.10-1, 3.11.5.10-2, and 3.11.5.10-3, respectively, may be used. For sound barriers supported on continuous vertical elements embedded in granular soil or cohesive soil, the simplified earth pressure distributions shown in Figures 3.11.5.10-4 and 3.11.5.10-5, respectively, may be used. For sound barriers supported on retaining walls, the applicable provisions of Section 11 shall apply.

Where discrete vertical elements are used for support, the width, b , of each vertical element shall be assumed to equal the width of the flange or diameter of the element for driven sections and the diameter of the concrete-filled hole for sections encased in concrete.

The reversal in the direction of applied lateral forces on sound barriers shall be considered in the design.

C3.11.5.10

Earth pressure on foundations of sound barriers is similar to that on nongravity retaining walls discussed in Article 3.11.5.6 except that the soil elevation on both sides of the wall is often the same or, if there is a difference, does not reach the top of the wall on one side. The provisions of this Article are applicable to the foundations of any wall that is not primarily intended to retain earth, i.e. there is no or little difference in the elevation of fill on either side of the wall.

In Figures 3.11.5.10-1 and 3.11.5.10-3, the width, b , of discrete vertical elements effective in mobilizing the passive resistance of the soil is based on a method of analysis by Broms (1964a, 1964b) for single vertical piles embedded in cohesive or granular soil. Additional information on the background of the earth pressure on discrete vertical elements is presented in Article C3.11.5.6.

The main applied lateral forces on sound barriers are wind and seismic forces; both of them are reversible. When the ground surface in front of or behind the sound barrier, or both, is not flat or the ground surface is not at the same elevation on both sides of the sound barrier, the design should be checked assuming that the lateral force is applied in either direction. The effect of the direction of ground surface slope, i.e. toward the barrier or away from the barrier, should be considered in earth pressure calculations for both directions of lateral loads. The earth pressure diagrams shown in Figures 3.11.5.10-1 through 3.11.5.10-5 correspond to the lateral load direction shown in these figures.

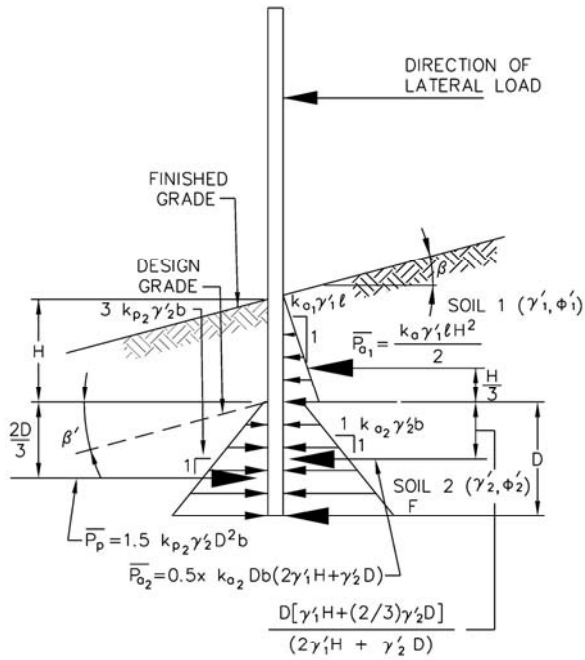

b = ACTUAL WIDTH OF EMBEDDED DISCRETE VERTICAL ELEMENT BELOW DESIGN GRADE IN PLANE OF BARRIER (FT.).

Figure 3.11.5.10-1—Unfactored Simplified Earth Pressure Distributions for Discrete Vertical Wall Elements Embedded in Granular Soil

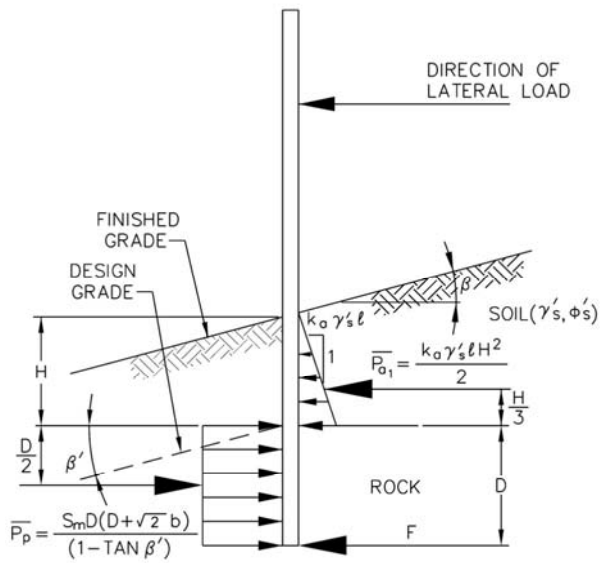

b = ACTUAL WIDTH OF EMBEDDED DISCRETE VERTICAL ELEMENT BELOW DESIGN GRADE IN PLANE OF BARRIER (FT.).

Figure 3.11.5.10-2—Unfactored Simplified Earth Pressure Distributions for Discrete Vertical Wall Elements Embedded in Rock

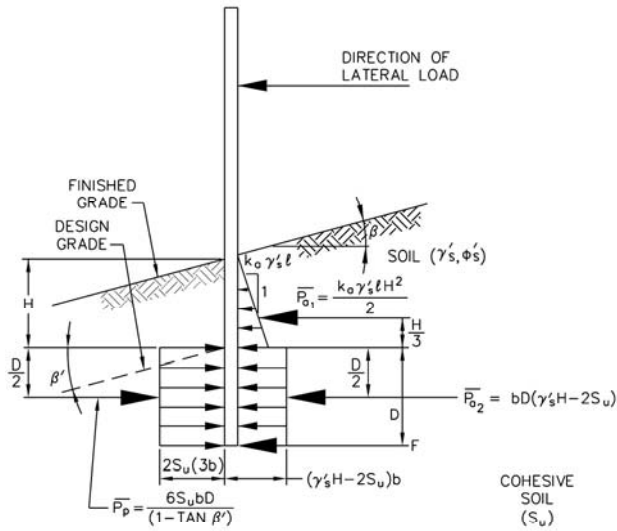

b = ACTUAL WIDTH OF EMBEDDED DISCRETE VERTICAL ELEMENT BELOW DESIGN GRADE IN PLANE OF BARRIER (FT.).

Figure 3.11.5.10-3—Unfactored Simplified Earth Pressure Distributions for Discrete Vertical Wall Elements Embedded in Cohesive Soil

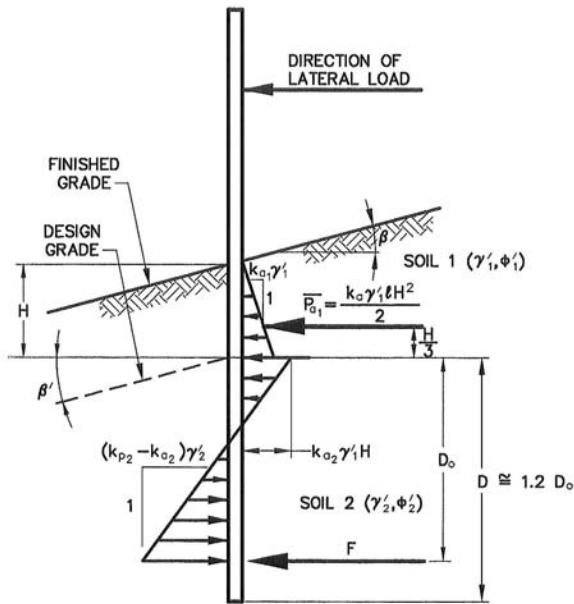

Figure 3.11.5.10-4—Unfactored Simplified Earth Pressure Distributions for Continuous Vertical Elements Embedded in Granular Soil Modified after Teng (1962)

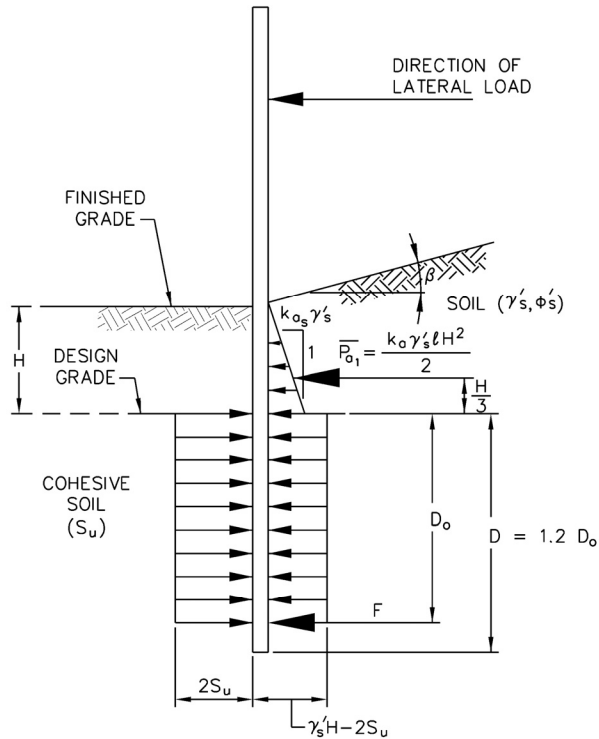

Figure 3.11.5.10-5—Unfactored Simplified Earth Pressure Distributions for Continuous Vertical Wall Elements Embedded in Cohesive Soil Modified after Teng (1962)

3.11.6—Surcharge Loads: *ES* and *LS*

The factored soil stress increase behind or within the wall caused by concentrated surcharge loads or stresses shall be the greater of (1) the unfactored surcharge loads or stresses multiplied by the specified load factor, *ES*, or (2) the factored loads for the structure as applied to the structural element causing the surcharge load, setting *ES* to 1.0. The load applied to the wall due to the structural element above the wall shall not be double factored.

C3.11.6

Concentrated surcharge loads induced by foundations are typically the result of dead load, live load, wind load, and possibly other loads that are associated with load factors other than *ES*. However, the controlling uncertainty in load prediction for surcharges is the transmission of the surcharge load through the soil to the wall or other structure below the surcharge. Hence, *ES* should be applied to the unfactored concentrated surcharge loads, unless the combined effect of the factored loads applicable to the foundation unit transmitting load to the top of the wall is more conservative. In this latter case, *ES* should be set equal to 1.0 and the factored footing loads used as the concentrated surcharge load in the wall design.

3.11.6.1—Uniform Surcharge Loads (*ES*)

Where a uniform surcharge is present, a constant horizontal earth pressure shall be added to the basic earth pressure. This constant earth pressure may be taken as:

$$\Delta_p = k_s q_s \quad (3.11.6.1-1)$$

where:

Δ_p = constant horizontal earth pressure due to uniform surcharge (ksf)

C3.11.6.1

When the uniform surcharge is produced by an earth loading on the upper surface, the load factor for both vertical and horizontal components shall be taken as specified in Table 3.4.1-2 for earth surcharge.

k_s = coefficient of earth pressure due to surcharge
 q_s = uniform surcharge applied to the upper surface of the active earth wedge (ksf)

For active earth pressure conditions, k_s shall be taken as k_a , and for at-rest conditions, k_s shall be taken as k_o . Otherwise, intermediate values appropriate for the type of backfill and amount of wall movement may be used.

3.11.6.2—Point, Line, and Strip Loads (ES): Walls Restrained from Movement

The horizontal pressure, Δ_{ph} in ksf, on a wall resulting from a uniformly loaded strip parallel to the wall may be taken as:

$$\Delta_{ph} = \frac{2p}{\pi} [\delta - \sin \delta \cos (\delta + 2\alpha)] \quad (3.11.6.2-1)$$

where:

- p = uniform load intensity on strip parallel to wall (ksf)
- α = angle specified in Figure 3.11.6.2-1 (rad)
- δ = angle specified in Figure 3.11.6.2-1 (rad)

Wall movement needed to mobilize extreme active and passive pressures for various types of backfill can be found in Table C3.11.1-1.

C3.11.6.2

Eqs. 3.11.6.2-2, 3.11.6.2-3, 3.11.6.2-4, and 3.11.6.2-5 are based on the assumption that the wall does not move, i.e., walls which have a high degree of structural rigidity or restrained at the top combined with an inability to slide in response to applied loads. For flexible walls, this assumption can be very conservative. Additional guidance regarding the ability of walls to move is provided in Article C3.11.1.

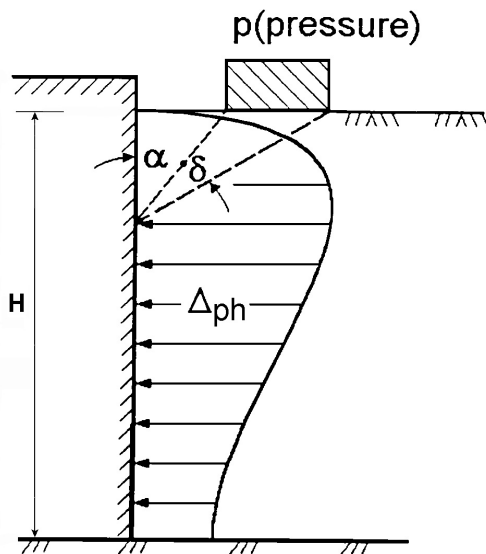

Figure 3.11.6.2-1—Horizontal Pressure on Wall Caused by a Uniformly Loaded Strip

The horizontal pressure, Δ_{ph} in ksf, on a wall resulting from a point load may be taken as:

$$\Delta_{ph} = \frac{P}{\pi R^2} \left[\frac{3ZX^2}{R^3} - \frac{R(1-2\nu)}{R+Z} \right] \quad (3.11.6.2-2)$$

where:

- P = point load (kip)
 R = radial distance from point of load application to a point on the wall as specified in Figure 3.11.6.2-2 where $R = (x^2 + y^2 + z^2)^{0.5}$ (ft)
 X = horizontal distance from back of wall to point of load application (ft)
 Y = horizontal distance from point on the wall under consideration to a plane, which is perpendicular to the wall and passes through the point of load application measured along the wall (ft)
 Z = vertical distance from point of load application to the elevation of a point on the wall under consideration (ft)
 ν = Poisson's ratio (dim.)

The point on the wall does not have to lie in a plane which is perpendicular to the wall and passes through the point of load application.

Poisson's ratio for soils varies from about 0.25 to 0.49, with lower values more typical for granular and stiff cohesive soils and higher values more typical for soft cohesive soils.

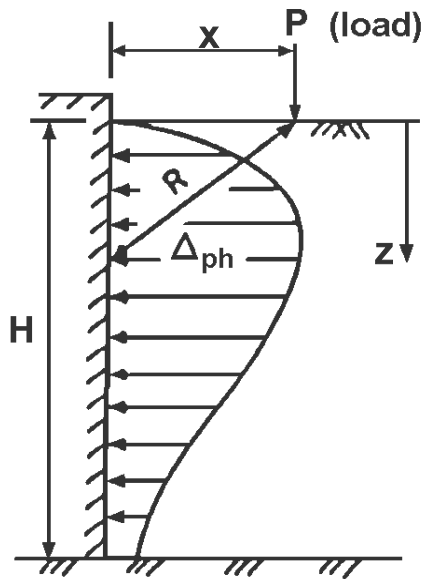

Figure 3.11.6.2-2—Horizontal Pressure on a Wall Caused by a Point Load

The horizontal pressure, Δ_{ph} in ksf, resulting from an infinitely long line load parallel to a wall may be taken as:

$$\Delta_{ph} = \frac{4Q}{\pi} \frac{X^2 Z}{R^4} \quad (3.11.6.2-3)$$

where:

Q = load intensity in kip/ft

and all other notation is as defined above and shown in Figure 3.11.6.2-3.

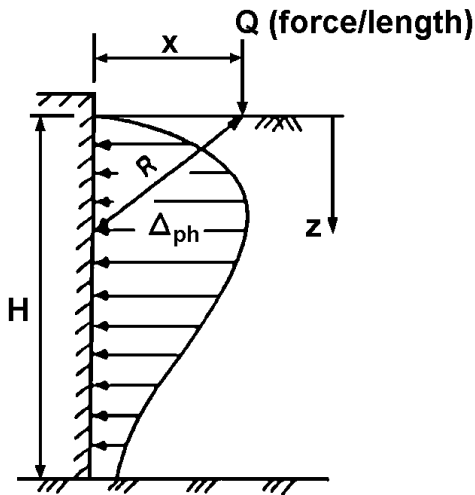

Figure 3.11.6.2-3—Horizontal Pressure on a Wall Caused by an Infinitely Long Line Load Parallel to the Wall

The horizontal pressure distribution, Δ_{ph} in ksf, on a wall resulting from a finite line load perpendicular to a wall may be taken as:

$$\Delta_{ph} = \frac{Q}{\pi Z} \left(\frac{1}{A^3} - \frac{1-2\nu}{A + \frac{Z}{X_2}} - \frac{1}{B^3} + \frac{1-2\nu}{B + \frac{Z}{X_1}} \right) \tag{3.11.6.2-4}$$

in which:

$$A = \sqrt{1 + \left(\frac{Z}{X_2} \right)^2} \tag{3.11.6.2-5}$$

$$B = \sqrt{1 + \left(\frac{Z}{X_1} \right)^2} \tag{3.11.6.2-6}$$

where:

- X_1 = distance from the back of the wall to the start of the line load as specified in Figure 3.11.6.2-4 (ft)
- X_2 = length of the line load (ft)
- Z = depth from the ground surface to a point on the wall under consideration (ft)
- ν = Poisson’s Ratio (dim.)
- Q = load intensity (kip/ft)

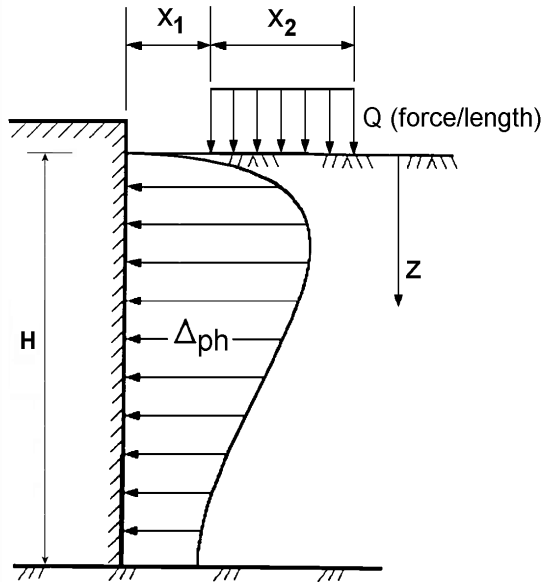

Figure 3.11.6.2-4—Horizontal Pressure on a Wall Caused by a Finite Line Load Perpendicular to the Wall

3.11.6.3—Strip Loads (ES): Flexible Walls

Concentrated dead loads shall be incorporated into the internal and external stability design by using a simplified uniform vertical distribution of 2 vertical to 1 horizontal to determine the vertical component of stress with depth within the reinforced soil mass as specified in Figure 3.11.6.3-1. Concentrated horizontal loads at the top of the wall shall be distributed within the reinforced soil mass as specified in Figure 3.11.6.3-2. If concentrated dead loads are located behind the reinforced soil mass, they shall be distributed in the same way as would be done within the reinforced soil mass.

The vertical stress distributed behind the reinforced zone shall be multiplied by k_a when determining the effect of this surcharge load on external stability. The concentrated horizontal stress distributed behind the wall as specified in Figure 3.11.6.3-2 shall not be multiplied by k_a .

C3.11.6.3

Figures 3.11.6.3-1 and 3.11.6.3-2 are based on the assumption that the wall is relatively free to move laterally (e.g., MSE walls).

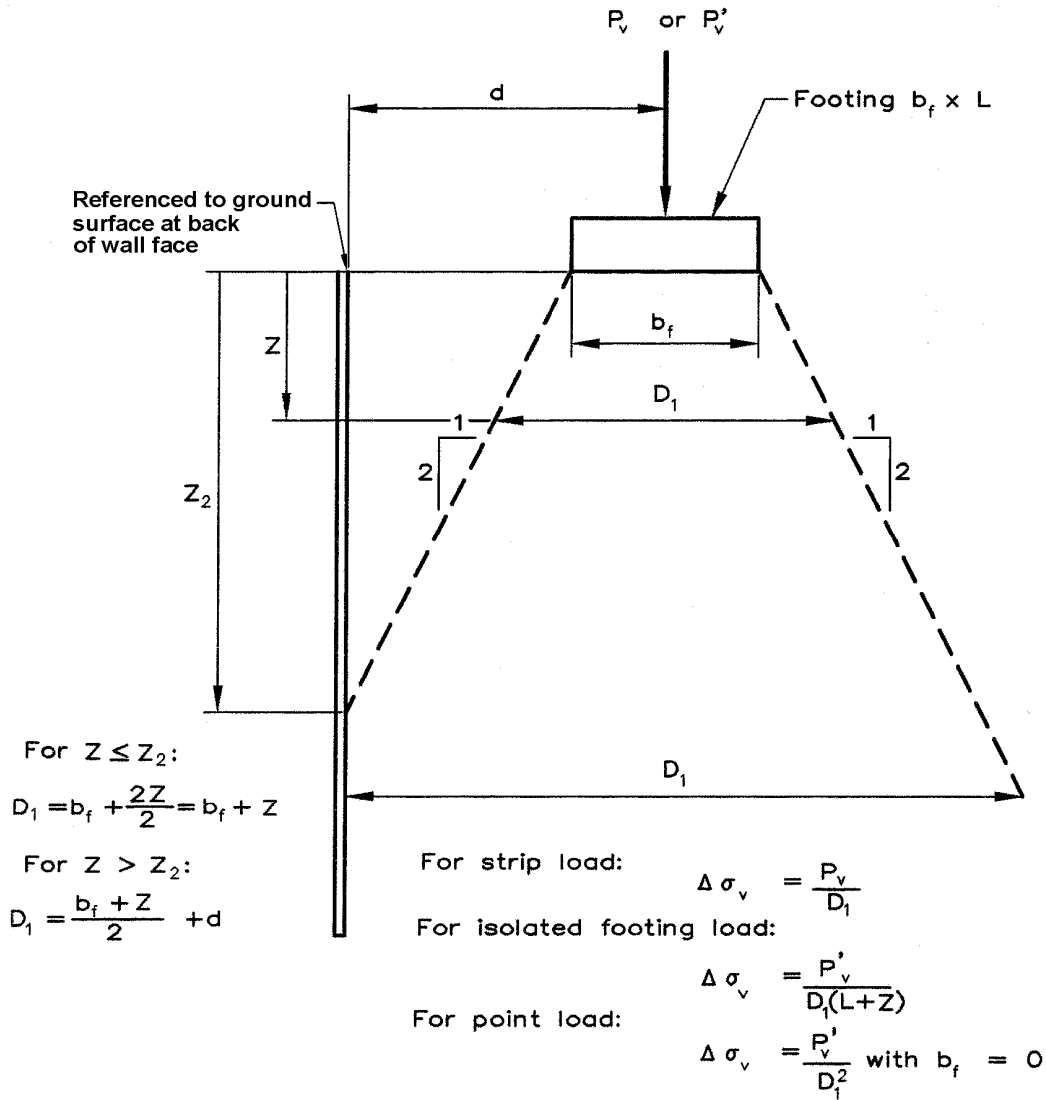

- Where: D_1 = Effective width of applied load at any depth, calculated as shown above
- b_f = Width of applied load. For footings which are eccentrically loaded (e.g., bridge abutment footings), set b_f equal to the equivalent footing width B' by reducing it by $2e'$, where e' is the eccentricity of the footing load (i.e., $b_f - 2e'$).
- L = Length of footing
- P_v = Load per linear foot of strip footing
- P'_v = Load on isolated rectangular footing or point load
- Z_2 = depth where effective width intersects back of wall face = $2d - b_f$
- d = distance between the centroid of the concentrated vertical load and the back of the wall face.

Assume the increased vertical stress due to the surcharge load has no influence on stresses used to evaluate internal stability if the surcharge load is located behind the reinforced soil mass. For external stability, assume the surcharge has no influence if it is located outside the active zone behind the wall.

Figure 3.11.6.3-1—Distribution of Stress from Concentrated Vertical Load P_v for Internal and External Stability Calculations

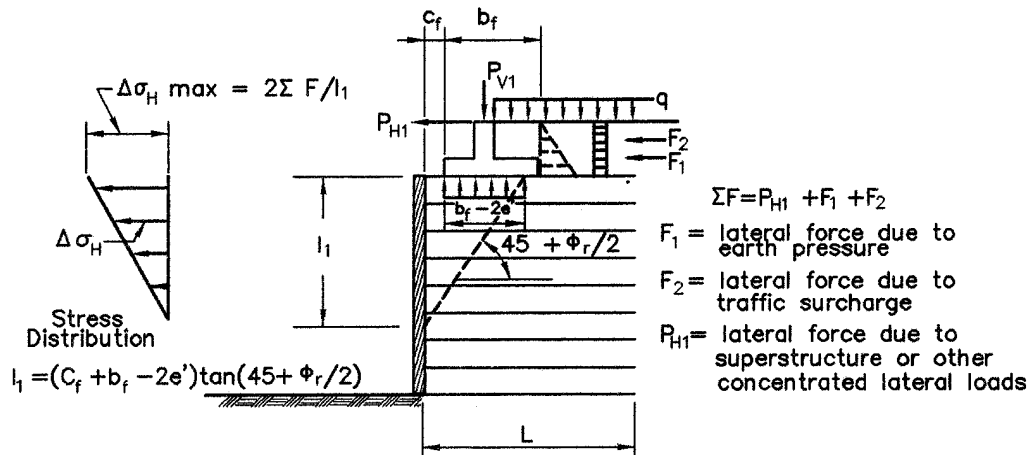

e' = eccentricity of load on footing (see Figure 11.10.10.1-1 for example of how to calculate this)

a—Distribution of Stress for Internal Stability Calculations

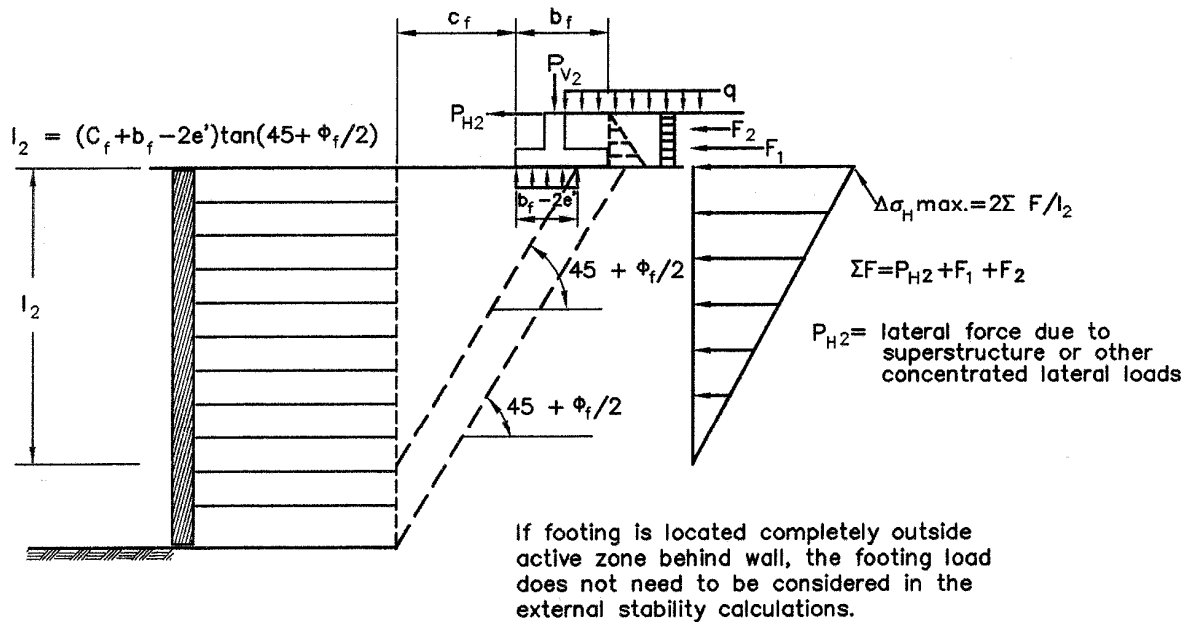

b—Distribution of Stress for External Stability Calculations

Figure 3.11.6.3-2—Distribution of Stress from Concentrated Horizontal Loads

3.11.6.4—Live Load Surcharge (LS)

A live load surcharge shall be applied where vehicular load is expected to act on the surface of the backfill within a distance equal to one-half the wall height behind the back face of the wall. If the surcharge is for a highway, the intensity of the load shall be consistent with the provisions of Article 3.6.1.2. If the surcharge is for other than a highway, the Owner shall specify and/or approve appropriate surcharge loads.

The increase in horizontal pressure due to live load surcharge may be estimated as:

C3.11.6.4

The tabulated values for h_{eq} were determined by evaluating the horizontal force against an abutment or wall from the pressure distribution produced by the vehicular live load of Article 3.6.1.2. The pressure distributions were developed from elastic half-space solutions using the following assumptions:

- Vehicle loads are distributed through a two-layer system consisting of pavement and soil subgrade

$$\Delta_p = k\gamma_s h_{eq} \quad (3.11.6.4-1)$$

where:

Δ_p = constant horizontal earth pressure due to live load surcharge (ksf)

γ_s = total unit weight of soil (kcf)

k = coefficient of lateral earth pressure

h_{eq} = equivalent height of soil for vehicular load (ft)

Equivalent heights of soil, h_{eq} , for highway loadings on abutments and retaining walls may be taken from Tables 3.11.6.4-1 and 3.11.6.4-2. Linear interpolation shall be used for intermediate wall heights.

The wall height shall be taken as the distance between the surface of the backfill and the bottom of the footing along the pressure surface being considered.

Table 3.11.6.4-1—Equivalent Height of Soil for Vehicular Loading on Abutments Perpendicular to Traffic

Abutment Height (ft)	h_{eq} (ft)
5.0	4.0
10.0	3.0
≥20.0	2.0

Table 3.11.6.4-2—Equivalent Height of Soil for Vehicular Loading on Retaining Walls Parallel to Traffic

Retaining Wall Height (ft)	h_{eq} (ft) Distance from wall backface to edge of traffic	
	0.0 ft	1.0 ft or Further
5.0	5.0	2.0
10.0	3.5	2.0
≥20.0	2.0	2.0

The load factor for both vertical and horizontal components of live load surcharge shall be taken as specified in Table 3.4.1-1 for live load surcharge.

3.11.6.5—Reduction of Surcharge

If the vehicular loading is transmitted through a structural slab, which is also supported by means other than earth, a corresponding reduction in the surcharge loads may be permitted.

- Poisson's ratio for the pavement and subgrade materials are 0.2 and 0.4, respectively
- Wheel loads were modeled as a finite number of point loads distributed across the tire area to produce an equivalent tire contact stress
- The process for equating wall moments resulting from the elastic solution with the equivalent surcharge method used a wall height increment of 0.25 ft.

The value of the coefficient of lateral earth pressure k is taken as k_o , specified in Article 3.11.5.2, for walls that do not deflect or move, or k_a , specified in Articles 3.11.5.3, 3.11.5.6 and 3.11.5.7, for walls that deflect or move sufficiently to reach minimum active conditions.

The analyses used to develop Tables 3.11.6.4-1 and 3.11.6.4-2 are presented in Kim and Barker (1998).

The values for h_{eq} given in Tables 3.11.6.4-1 and 3.11.6.4-2 are generally greater than the traditional 2.0 ft of earth load historically used in the AASHTO specifications, but less than those prescribed in previous editions (i.e., before 1998) of this specification. The traditional value corresponds to a 20.0-kip single unit truck formerly known as an H10 truck, Peck et al. (1974). This partially explains the increase in h_{eq} in previous editions of this specification. Subsequent analyses, i.e., Kim and Barker (1998) show the importance of the direction of traffic, i.e., parallel for a wall and perpendicular for an abutment on the magnitude of h_{eq} . The magnitude of h_{eq} is greater for an abutment than for a wall due to the proximity and closer spacing of wheel loads to the back of an abutment compared to a wall.

The backface of the wall should be taken as the pressure surface being considered. Refer to Article C11.5.5 for application of surcharge pressures on retaining walls.

C3.11.6.5

This Article relates primarily to approach slabs which are supported at one edge by the backwall of an abutment, thus transmitting load directly thereto.

3.11.7—Reduction Due to Earth Pressure

For culverts and bridges and their components where earth pressure may reduce effects caused by other loads and forces, such reduction shall be limited to the extent earth pressure can be expected to be permanently present. In lieu of more precise information, a 50 percent reduction may be used, but need not be combined with the minimum load factor specified in Table 3.4.1-2.

3.11.8—Downdrag

Possible development of downdrag on piles or shafts shall be evaluated where:

- Sites are underlain by compressible material such as clays, silts or organic soils,
- Fill will be or has recently been placed adjacent to the piles or shafts, such as is frequently the case for bridge approach fills,
- The groundwater is substantially lowered, or
- Liquefaction of loose sandy soil can occur.

When the potential exists for downdrag to act on a pile or shaft due to downward movement of the soil relative to the pile or shaft, and the potential for downdrag is not eliminated by preloading the soil to reduce downward movements or other mitigating measure, the pile or shaft shall be designed to resist the induced downdrag.

Consideration shall be given to eliminating the potential for downdrag loads through the use of embankment surcharge loads, ground improvement techniques, and/or vertical drainage and settlement monitoring measurements.

For Extreme Event I limit state, downdrag induced by liquefaction settlement shall be applied to the pile or shaft in combination with the other loads included within that load group. Liquefaction-induced downdrag shall not be combined with downdrag induced by consolidation settlements.

For downdrag load applied to pile or shaft groups, group effects shall be evaluated.

C3.11.7

This provision is intended to refine the traditional approach in which the earth pressure is reduced by 50 percent in order to obtain maximum positive moment in top slab of culverts and frames. It permits obtaining more precise estimates of force effects where earth pressures are present.

C3.11.8

Downdrag, also known as negative skin friction, can be caused by soil settlement due to loads applied after the piles were driven, such as an approach embankment as shown in Figure C3.11.8-1. Consolidation can also occur due to recent lowering of the groundwater level as shown in Figure C3.11.8-2.

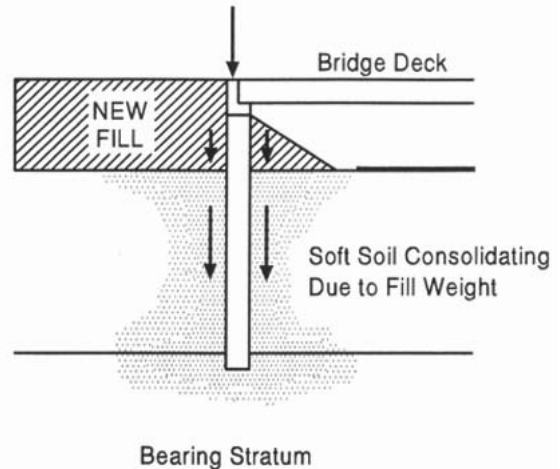

Figure C3.11.8-1—Common Downdrag Situation Due to Fill Weight (Hannigan, et al., 2005)

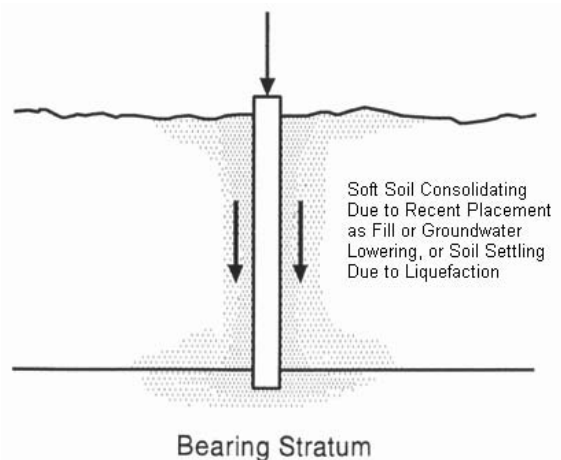

Figure C3.11.8-2—Common Downdrag Situation Due to Causes Other than Recent Fill Placement

Regarding the load factors for downdrag in Table 3.4.1-2, use the maximum load factor when investigating maximum downward pile loads. The minimum load factor shall only be utilized when investigating possible uplift loads.

For some downdrag estimation methods, the magnitude of the load factor is dependent on the magnitude of the downdrag load relative to the dead load. The downdrag load factors were developed considering that downdrag loads equal to or greater than the magnitude of the dead load become somewhat impractical for design. See Allen (2005) for additional background and guidance on the effect of downdrag load magnitude.

Methods for eliminating static downdrag potential include preloading. The procedure for designing a preload is presented in Cheney and Chassie (2000).

Post-liquefaction settlement can also cause downdrag. Methods for mitigating liquefaction-induced downdrag are presented in Kavazanjian, et al. (1997).

The application of downdrag to pile or shaft groups can be complex. If the pile or shaft cap is near or below the fill material causing consolidation settlement of the underlying soft soil, the cap will prevent transfer of stresses adequate to produce settlement of the soil inside the pile or shaft group. The downdrag applied in this case is the frictional force around the exterior of the pile or shaft group and along the sides of the pile or shaft cap (if any). If the cap is located well up in the fill causing consolidation stresses or if the piles or shafts are used as individual columns to support the structure above ground, the downdrag on each individual pile or shaft will control the magnitude of the load. If group effects are likely, the downdrag calculated using the group perimeter shear force should be determined in addition to the sum of the downdrag forces for each individual pile or shaft. The greater of the two calculations should be used for design.

The skin friction used to estimate downdrag due to liquefaction settlement should be conservatively assumed to be equal to the residual soil strength in the liquefiable zone, and nonliquefied skin friction in nonliquefiable layers above the zone of liquefaction.

Transient loads can act to reduce the downdrag because they cause a downward movement of the pile resulting in a temporary reduction or elimination of the downdrag load. It is conservative to include the transient loads together with downdrag.

The step-by-step procedure for determining downdrag is presented in detail in Hannigan, et al. (2005).

The stress increases in each soil layer due to embankment load can be estimated using the procedures in Hannigan et al. (2005) or Cheney and Chassie (2000).

If the settlement is due to liquefaction, the Tokimatsu and Seed (1987) or the Ishihara and Yoshimine (1992) procedures can be used to estimate settlement.

If transient loads act to reduce the magnitude of downdrag loads and this reduction is considered in the design of the pile or shaft, the reduction shall not exceed that portion of transient load equal to the downdrag force effect.

Force effects due to downdrag on piles or drilled shafts should be determined as follows:

Step 1—Establish soil profile and soil properties for computing settlement using the procedures in Article 10.4.

Step 2—Perform settlement computations for the soil layers along the length of the pile or shaft using the procedures in Article 10.6.2.4.3.

Step 3—Determine the length of pile or shaft that will be subject to downdrag. If the settlement in the soil layer is 0.4 in. or greater relative to the pile or shaft, downdrag can be assumed to fully develop.

Step 4—Determine the magnitude of the downdrag, DD , by computing the negative skin resistance using any of the static analysis procedures in Article 10.7.3.8.6 for piles in all soils and Article 10.8.3.4 for shafts if the zone subject to downdrag is characterized as a cohesive soil. If the downdrag zone is characterized as a cohesionless soil, the procedures provided in Article 10.8.3.4 should be used to estimate the downdrag for shafts. Sum the negative skin resistance for all layers contributing to downdrag from the lowest layer to the bottom of the pile cap or ground surface.

The neutral plane method may also be used to determine downdrag.

The methods used to estimate downdrag are the same as those used to estimate skin friction, as described in Articles 10.7 and 10.8. The distinction between the two is that downdrag acts downward on the sides of the piles or shafts and loads the foundation, whereas skin friction acts upward on the sides of piles or shafts and, thus, supports the foundation loads.

Downdrag can be estimated for piles using the α or λ methods for cohesive soils. An alternative approach would be to use the β method where the long-term conditions after consolidation should be considered. Cohesionless soil layers overlying the consolidating layers will also contribute to downdrag, and the negative skin resistance in these layers should be estimated using an effective stress method.

Downdrag loads for shafts may be estimated using the α method for cohesive soils and the β method for granular soils, as specified in Article 10.8, for calculating negative shaft resistance. As with positive shaft resistance, the top 5.0 ft and a bottom length taken as one shaft diameter do not contribute to downdrag loads. When using the α method, an allowance should be made for a possible increase in the undrained shear strength as consolidation occurs.

The neutral plane method is described and discussed in NCHRP 393 (Briaud and Tucker, 1993).

3.12—FORCE EFFECTS DUE TO SUPERIMPOSED DEFORMATIONS: TU , TG , SH , CR , SE , PS

3.12.1—General

Internal force effects in a component due to creep and shrinkage shall be considered. The effect of a temperature gradient should be included where appropriate. Force effects resulting from resisting component deformation, displacement of points of load application, and support movements shall be included in the analysis.

3.12.2—Uniform Temperature

The design thermal movement associated with a uniform temperature change may be calculated using Procedure A or Procedure B below. Either Procedure A or Procedure B may be employed for concrete deck bridges having concrete or steel girders. Procedure A shall be employed for all other bridge types.

3.12.2.1—Temperature Range for Procedure A

The ranges of temperature shall be as specified in Table 3.12.2.1-1. The difference between the extended lower or upper boundary and the base construction temperature assumed in the design shall be used to calculate thermal deformation effects.

C3.12.2.1

Procedure A is the historic method that has been used for bridge design.

For these Specifications, a moderate climate may be determined by the number of freezing days per yr. If the number of freezing days is less than 14, the climate is considered to be moderate. Freezing days are days when the average temperature is less than 32°F.

The minimum and maximum temperatures specified in Table 3.12.2.1-1 shall be taken as $T_{MinDesign}$ and $T_{MaxDesign}$, respectively, in Eq. 3.12.2.3-1.

Although temperature changes in a bridge do not occur uniformly, bridges generally are designed for an assumed uniform temperature change. The orientation of bearing guides and the freedom of bearing movement is important. Sharp curvature and sharply skewed supports can cause excessive lateral thermal forces at supports if only tangential movement is permitted. Wide bridges are particularly prone to large lateral thermal forces because the bridge expands radially as well as longitudinally.

Table 3.12.2.1-1—Procedure A Temperature Ranges

Climate	Steel or Aluminum	Concrete	Wood
Moderate	0° to 120°F	10° to 80°F	10° to 75°F
Cold	-30° to 120°F	0° to 80°F	0° to 75°F

3.12.2.2—Temperature Range for Procedure B

The temperature range shall be defined as the difference between the maximum design temperature, $T_{MaxDesign}$, and the minimum design temperature, $T_{MinDesign}$. For all concrete girder bridges with concrete decks, $T_{MaxDesign}$ shall be determined from the contours of Figure 3.12.2.2-1 and $T_{MinDesign}$ shall be determined from the contours of Figure 3.12.2.1-2. For steel girder bridges with concrete decks, $T_{MaxDesign}$ shall be determined from the contours of Figure 3.12.2.1-3 and $T_{MinDesign}$ shall be determined from the contours of Figure 3.12.2.1-4.

C3.12.2.2

The Procedure B design was developed on the basis of the report *Thermal Movement Design Procedure for Steel and Concrete Bridges* (Roeder, 2002).

Procedure B is a calibrated procedure and does not cover all bridge types. The temperatures provided in the maps of Figures 3.12.2.1-1 to 3.12.2.1-4 are extreme bridge design temperatures for an average history of 70 yr with a minimum of 60 yr of data for locations throughout the U.S.

The design values for locations between contours should be determined by linear interpolation. As an alternative method, the largest adjacent contour may be used to define $T_{MaxDesign}$ and the smallest adjacent contour may be used to define $T_{MinDesign}$. Both the minimum and maximum design temperatures should be noted on the drawings for the girders, expansion joints, and bearings.

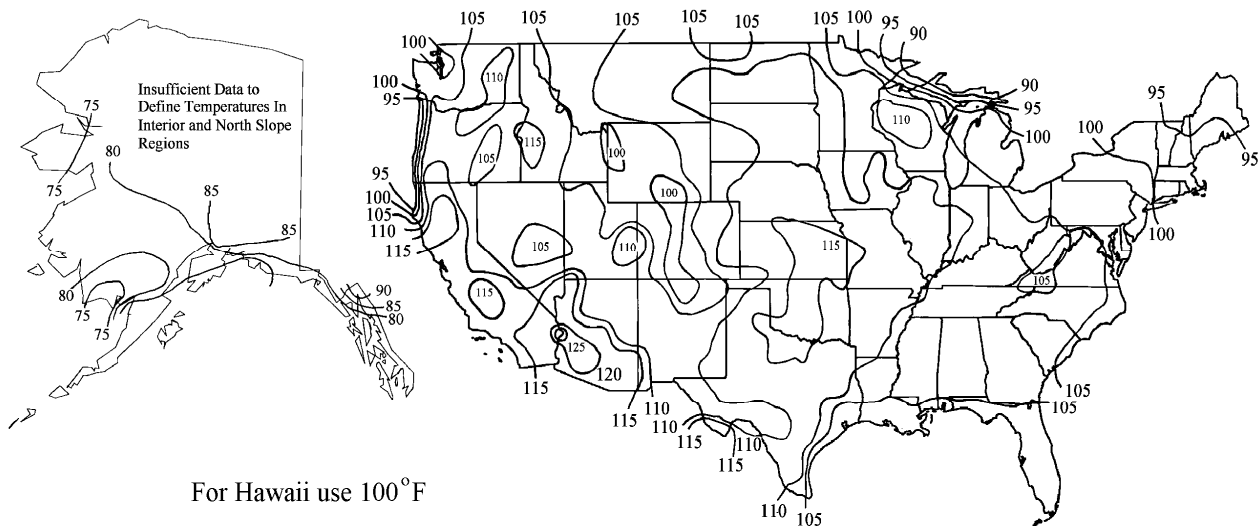

Figure 3.12.2.2-1—Contour Maps for $T_{MaxDesign}$ for Concrete Girder Bridges with Concrete Decks

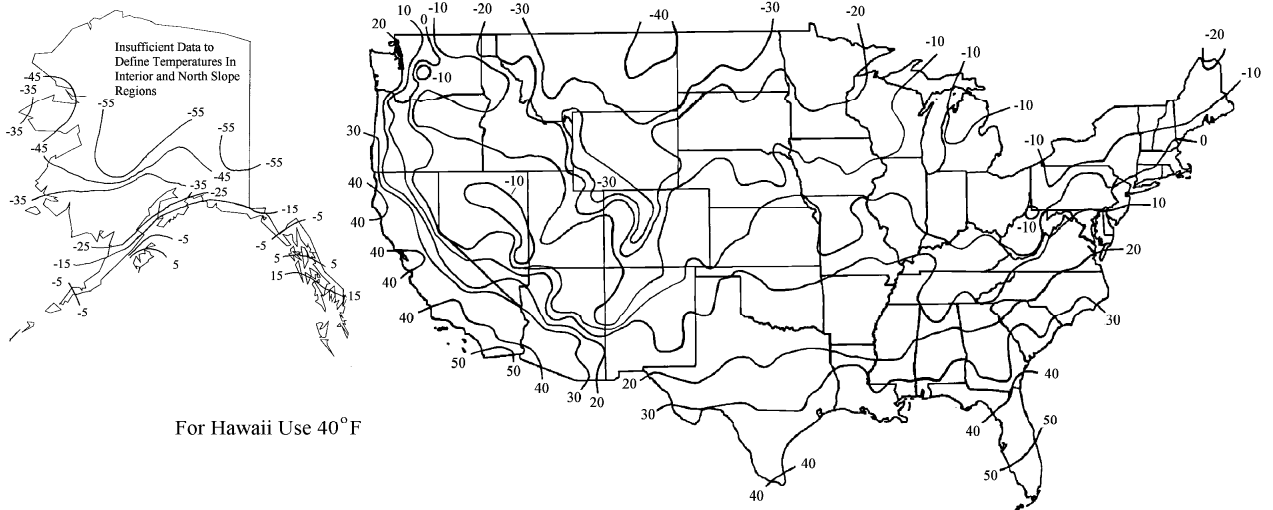

Figure 3.12.2.2-2—Contour Maps for $T_{MinDesign}$ for Concrete Girder Bridges with Concrete Decks

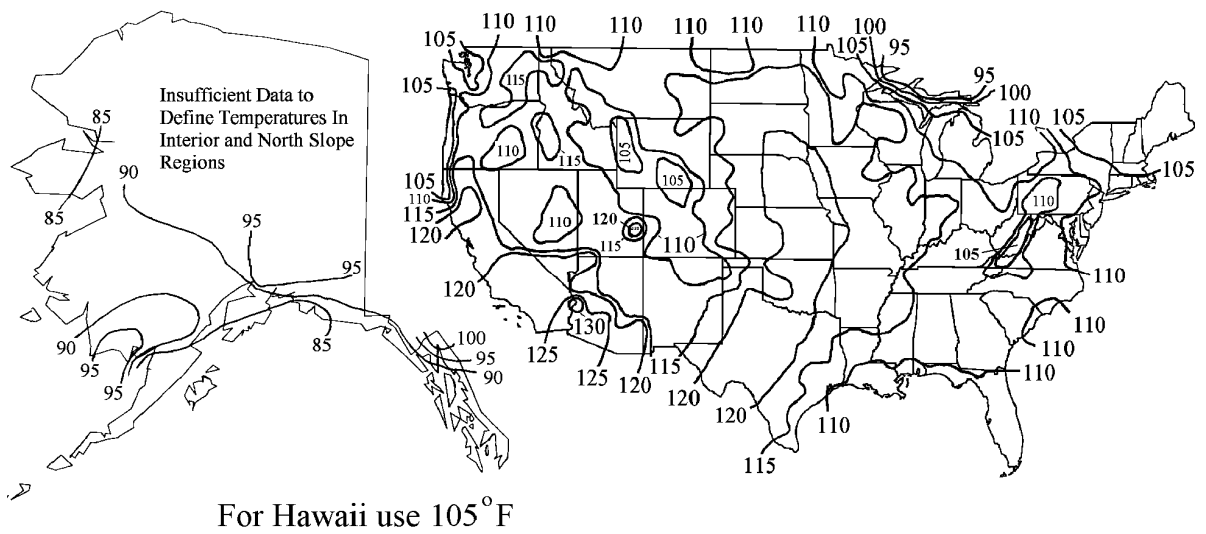

Figure 3.12.2.2-3—Contour Maps for $T_{MaxDesign}$ for Steel Girder Bridges with Concrete Decks

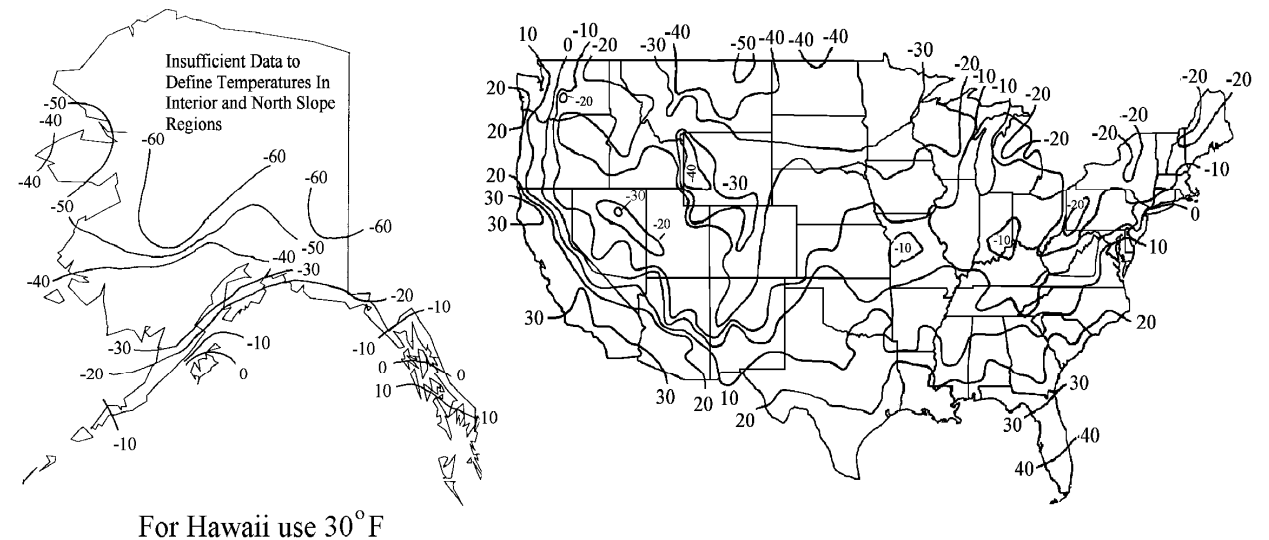

Figure 3.12.2.2-4—Contour Maps for $T_{MinDesign}$ for Steel Girder Bridges with Concrete Decks

3.12.2.3—Design Thermal Movements

The design thermal movement range, Δ_T , shall depend upon the extreme bridge design temperatures defined in Article 3.12.2.1 or 3.12.2.2, and be determined as:

$$\Delta_T = \alpha L (T_{MaxDesign} - T_{MinDesign}) \quad (3.12.2.3-1)$$

where:

L = expansion length (in.)

α = coefficient of thermal expansion (in./in./°F)

3.12.3—Temperature Gradient

For the purpose of this Article, the country shall be subdivided into zones as indicated in Figure 3.12.3-1. Positive temperature values for the zones shall be taken as specified for various deck surface conditions in Table 3.12.3-1. Negative temperature values shall be obtained by multiplying the values specified in Table 3.12.3-1 by -0.30 for plain concrete decks and -0.20 for decks with an asphalt overlay.

The vertical temperature gradient in concrete and steel superstructures with concrete decks may be taken as shown in Figure 3.12.3-2.

Dimension A in Figure 3.12.3-2 shall be taken as:

- For concrete superstructures that are 16.0 in. or more in depth—12.0 in.
- For concrete sections shallower than 16.0 in.—4.0 in. less than the actual depth
- For steel superstructures—12.0 in. and the distance t shall be taken as the depth of the concrete deck

Temperature value T_3 shall be taken as 0.0°F, unless a site-specific study is made to determine an appropriate value, but it shall not exceed 5°F.

Where temperature gradient is considered, internal stresses and structure deformations due to both positive and negative temperature gradients may be determined in accordance with the provisions of Article 4.6.6.

Table 3.12.3-1—Basis for Temperature Gradients

Zone	T_1 (°F)	T_2 (°F)
1	54	14
2	46	12
3	41	11
4	38	9

C3.12.3

Temperature gradient is included in various load combinations in Table 3.4.1-1. This does not mean that it need be investigated for all types of structures. If experience has shown that neglecting temperature gradient in the design of a given type of structure has not lead to structural distress, the Owner may choose to exclude temperature gradient. Multibeam bridges are an example of a type of structure for which judgment and past experience should be considered.

Redistribution of reactive loads, both longitudinally and transversely, should also be calculated and considered in the design of the bearings and substructures.

The temperature gradient given herein is a modification of that proposed in Imbsen et al. (1985), which was based on studies of concrete superstructures. The addition for steel superstructures is patterned after the temperature gradient for that type of bridge in the Australian bridge specifications (AUSTROADS, 1992).

The data in Table 3.12.3-1 does not make a distinction regarding the presence or lack of an asphaltic overlay on decks. Field measurements have yielded apparently different indications concerning the effect of asphalt as an insulator or as a contributor (Spring, 1997). Therefore, any possible insulating qualities have been ignored herein.

The temperatures given in Table 3.12.3-1 form the basis for calculating the change in temperature with depth in the cross-section, not absolute temperature.

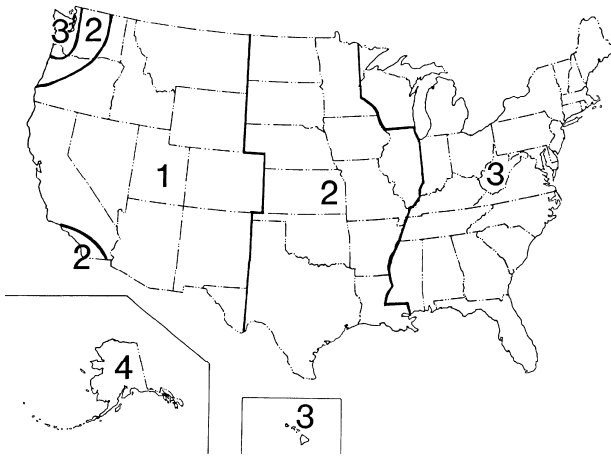

Figure 3.12.3-1—Solar Radiation Zones for the United States

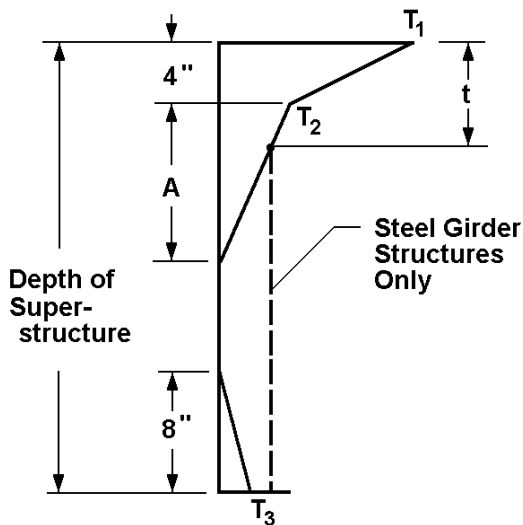

Figure 3.12.3-2—Positive Vertical Temperature Gradient in Concrete and Steel Superstructures

3.12.4—Differential Shrinkage

Where appropriate, differential shrinkage strains between concretes of different age and composition, and between concrete and steel or wood, shall be determined in accordance with the provisions of Section 5.

3.12.5—Creep

Creep strains for concrete and wood shall be in accordance with the provisions of Section 5 and Section 8, respectively. In determining force effects and deformations due to creep, dependence on time and changes in compressive stresses shall be taken into account.

C3.12.4

The Designer may specify timing and sequence of construction in order to minimize stresses due to differential shrinkage between components. The load factor may be reduced to 1.0 if physical testing is performed to establish material properties and upper bound values are used in the analysis.

C3.12.5

Traditionally, only creep of concrete is considered. Creep of wood is addressed only because it applies to prestressed wood decks. The load factor may be reduced to 1.0 if physical testing is performed to establish material properties and upper bound values are used in the analysis.

3.12.6—Settlement

Force effects due to extreme values of differential settlements among substructures and within individual substructure units shall be considered. Estimates of settlement for individual substructure units may be made in accordance with the provisions in Article 10.7.2.3.

3.12.7—Secondary Forces from Post-Tensioning, *PS*

The application of post-tensioning forces on a continuous structure produces reactions at the supports and internal forces that are collectively called secondary forces, which shall be considered where applicable.

3.13—FRICTION FORCES: *FR*

Forces due to friction shall be established on the basis of extreme values of the friction coefficient between the sliding surfaces. Where appropriate, the effect of moisture and possible degradation or contamination of sliding or rotating surfaces upon the friction coefficient shall be considered.

3.14—VESSEL COLLISION: *CV***3.14.1—General**

The provisions of this Article apply to the accidental collision between a vessel and a bridge. These provisions may be revised as stated in Article 3.14.16 to account for intentional collisions.

All bridge components in a navigable waterway crossing, located in design water depths not less than 2.0 ft, shall be designed for vessel impact.

The minimum design impact load for substructure design shall be determined using an empty hopper barge drifting at a velocity equal to the yearly mean current for the waterway location. The design barge shall be a single 35.0-ft × 195-ft barge, with an empty displacement of 200 ton, unless approved otherwise by the Owner.

Where bridges span deep draft waterways and are not sufficiently high to preclude contact with the vessel, the minimum superstructure design impact may be taken to be the mast collision impact load specified in Article 3.14.10.3.

C3.12.6

Force effects due to settlement may be reduced by considering creep. Analysis for the load combinations in Tables 3.4.1-1 and 3.4.1-2 which include settlement should be repeated for settlement of each possible substructure unit settling individually, as well as combinations of substructure units settling, that could create critical force effects in the structure.

C3.12.7

In frame analysis software, secondary forces are generally obtained by subtracting the primary prestress forces from the total prestressing.

C3.13

Low and high friction coefficients may be obtained from standard textbooks. If so warranted, the values may be determined by physical tests, especially if the surfaces are expected to be roughened in service.

C3.14.1

Intentional collision between a vessel and a bridge may be considered when conducting security studies.

The determination of the navigability of a waterway is usually made by the U.S. Coast Guard.

The requirements herein have been adapted from the *AASHTO Guide Specifications and Commentary for Vessel Collision Design of Highway Bridges (1991)* using the Method II risk acceptance alternative, and modified for the second edition (2009). The 1991 Guide Specifications required the use of a single vessel length overall (*LOA*) selected in accordance with the Method I criteria for use in estimating the geometric probability and impact speed to represent all vessel classifications. This was a conservative simplification applied to reduce the amount of effort required in the analysis. With the introduction of personal computers and programming, the simplification can be lifted and *AF* can be quickly obtained for each design vessel, which was originally envisioned. The end result is a more accurate model for the vessel collision study as well as more informative conclusions about the vessel fleet and associated probabilities of collision.

Another source of information has been the proceedings of an international colloquium, *Ship Collisions with Bridges and Offshore Structures (IABSE, 1983)*.

Barges are categorized by ton = 2,000 lbs. and ships by tonne = 2,205 lbs.

In navigable waterways where vessel collision is anticipated, structures shall be:

- Designed to resist vessel collision forces, and/or
- Adequately protected by fenders, dolphins, berms, islands, or other sacrifice-able devices.

In determining vessel collision loads, consideration shall be given to the relationship of the bridge to:

- Waterway geometry,
- Size, type, loading condition, and frequency of vessels using the waterway,
- Available water depth,
- Vessel speed and direction, and
- The structural response of the bridge to collision.

The deadweight tonnage (DWT) of a ship is the weight of the cargo, fuel, water, and stores. The DWT is only a portion of the total vessel weight, but it gives a general estimation of the ship size.

A minimum impact requirement from an empty barge drifting in all waterways and the mast impact of a drifting ship in deep draft waterways is specified because of the high frequency of occurrences of such collision accidents in United States' waterways.

The intent of the vessel collision provisions is to minimize the risk of catastrophic failure of bridges crossing navigable waterways due to collisions by aberrant vessels. The collision impact forces represent a probabilistically based, worst-case, head-on collision, with the vessel moving in a forward direction at a relatively high velocity. The requirements are applicable to steel-hulled merchant ships larger than 1,000 DWT and to inland waterway barges.

The channel layout and geometry can affect the navigation conditions, the largest vessel size that can use the waterway and the loading condition and the speed of vessels approaching a bridge. The presence of bends, intersections with other waterways, and the presence of other bridge crossings near the bridge increase the probability of accidents. The vessel transit paths in the waterway in relation to the navigation channel and the bridge piers can affect the risk of aberrant vessels hitting the piers and the exposed portions of the superstructure.

The water level and the loading conditions of vessels influence the location on the pier where vessel impact loads are applied, and the susceptibility of the superstructure to vessel hits. The water depth plays a critical role in the accessibility of vessels to piers and spans outside the navigation channel. The water depth at the pier should not include short-term scour. In addition, the water depth should not just be evaluated at the specific pier location itself, but also at locations upstream and downstream of the pier—which may be shallower and would potentially block certain deeper draft vessels from hitting the pier. In waterways with large water stage fluctuations, the water level used can have a significant effect on the structural requirements for the pier and/or pier protection design.

The maneuverability of ships is reduced by the low underkeel clearance typical in inland waterways. Shallow underkeel clearance can also affect the hydrodynamic forces during a collision increasing the collision energy, especially in the transverse direction. In addition, ships riding in ballast can be greatly affected by winds and currents. When under ballast, vessels are susceptible to wind gusts that could push them into the bridge.

It is very difficult to control and steer barge tows, especially near bends and in waterways with high stream velocities and cross currents. In maneuvering a bend, tows experience a sliding effect in a direction opposite to the direction of the turn, due to inertia forces which are often coupled with the current flow. Bridges located in a high velocity waterway and near a bend in the channel will probably be hit by barges at frequent intervals.

Unless otherwise indicated in these Specifications, an evaluation of the following two vessel collision events combined with scour conditions are recommended:

- A drifting empty barge breaking loose from its moorings and striking the bridge. The vessel impact loads should be combined with one-half of the predicted long-term scour plus one-half of the predicted short term scour. The flow rate, water level, and short-term scour depth are those associated with the design flood for bridge scour (100-year flood event).

A ship or barge tow striking the bridge while transiting the navigation channel under typical waterway conditions. The vessel impact loads should be combined with the effects of one-half of the long-term scour and no short-term scour. The flow rate and water level should be taken as the yearly mean conditions.

3.14.2—Owner’s Responsibility

The Owner shall establish and/or approve the bridge operational classification, the vessel traffic density in the waterway, and the design velocity of vessels for the bridge. The Owner shall specify or approve the degree of damage that the bridge components, including protective systems, are allowed to sustain.

3.14.3—Operational Classification

For the purpose of Article 3.14, an operational classification, either “critical or essential” or “typical,” shall be determined for all bridges located in navigable waterways. Critical bridges shall continue to function after an impact, the probability of which is smaller than regular bridges.

3.14.4—Design Vessel

A design vessel for each pier or span component shall be selected, such that the estimated annual frequency of collapse computed in accordance with Article 3.14.5, due to vessels not smaller than the design vessel, is less than the acceptance criterion for the component.

The design vessels shall be selected on the basis of the bridge operational classification and the vessel, bridge, and waterway characteristics.

C3.14.2

Pier protection systems may also be warranted for bridges over navigable channels transversed only by pleasure boats or small commercial vessels. For such locations, dolphins and fender systems are commonly used to protect the pier and to minimize the hazards of passage under the bridge for the vessels using the waterway.

C3.14.3

This Article implies that a critical or essential bridge may be damaged to an extent acceptable to the Owner, as specified in Article 3.14.2, but should not collapse and should remain serviceable, even though repairs are needed.

C3.14.4

An analysis of the annual frequency of collapse is performed for each pier or span component exposed to collision. From this analysis, a design vessel and its associated collision loads can be determined for each pier or span component. The design vessel size and impact loads can vary greatly among the components of the same structure, depending upon the waterway geometry, available water depth, bridge geometry, and vessel traffic characteristics.

The design vessel is selected using a probability-based analysis procedure in which the predicted annual frequency of bridge collapse, AF , is compared to an acceptance criterion. The analysis procedure is an iterative process in which a trial design vessel is selected for a bridge component and a resulting AF is computed using the characteristics of waterway, bridge, and vessel fleet. This AF is compared to the acceptance criterion, and revisions to the analysis variables are made as necessary to achieve compliance. The primary variables that the Designer can usually alter include the:

3.14.5—Annual Frequency of Collapse

The annual frequency of a bridge component collapse shall be taken as:

$$AF = (N)(PA)(PG)(PC)(PF) \quad (3.14.5-1)$$

where:

- AF = annual frequency of bridge component collapse due to vessel collision
 N = the annual number of vessels, classified by type, size, and loading condition, that utilize the channel
 PA = the probability of vessel aberrancy
 PG = the geometric probability of a collision between an aberrant vessel and a bridge pier or span
 PC = the probability of bridge collapse due to a collision with an aberrant vessel
 PF = adjustment factor to account for potential protection of the piers from vessel collision due to upstream or downstream land masses or other structures that block the vessel

AF shall be computed for each bridge component and vessel classification. The annual frequency of collapse for the total bridge shall be taken as the sum of all component AF s.

For critical or essential bridges, the maximum annual frequency of collapse, AF , for the whole bridge, shall be taken as 0.0001.

For typical bridges, the maximum annual frequency of collapse, AF , for the total bridge, shall be taken as 0.001.

For waterways with widths less than 6.0 times the length overall of the design vessel, LOA , the acceptance criterion for the annual frequency of collapse for each pier and superstructure component shall be determined by distributing the total bridge acceptance criterion, AF , over the number of pier and span components located in the waterway.

For wide waterways with widths greater than 6.0 times LOA , the acceptance criterion for the annual frequency of collapse for each pier and span component shall be determined by distributing the total bridge acceptance criterion over the number of pier and superstructure components located within the distance 3.0 times LOA on each side of the inbound and outbound vessel transit centerline paths.

- Location of the bridge in the waterway,
- Location and clearances of bridge pier and span components,
- Resistance of piers and superstructures, and
- Use of protective systems to either reduce or eliminate the collision forces.

C3.14.5

Various types of risk assessment models have been developed for vessel collision with bridges by researchers worldwide (IABSE, 1983; Modjeski and Masters, 1984; Prucz, 1987; Larsen, 1993). Practically all of these models are based on a form similar to Eq. 3.14.5-1, which is used to compute the annual frequency of bridge collapse, AF , associated with a particular bridge component.

The inverse of the annual frequency of collapse, $1/AF$, is equal to the return period in yr. The summation of AF s computed over all of the vessel classification intervals for a specific component equals the annual frequency of collapse of the component.

Risk can be defined as the potential realization of unwanted consequences of an event. Both a probability of occurrence of an event and the magnitude of its consequences are involved. Defining an acceptable level of risk is a value-oriented process and is by nature subjective (Rowe, 1977).

Based on historical collision data, the primary area of concern for vessel impact is the central portion of the bridge near the navigation channel. The limits of this area extend to a distance of 3.0 times LOA on each side of the inbound and outbound vessel transit path centerlines. For most bridges, these vessel transit path centerlines coincide with the centerline of the navigable channel. Where two-way vessel traffic exists under the bridge, the vessel transit path centerline of the inbound and outbound vessels should be taken as the centerline of each half of the channel, respectively.

The distribution of the AF acceptance criterion among the exposed pier and span components is based on the Designer's judgment. One method is to equally spread the acceptable risk among all the components. This method is usually not desirable because it fails to take into account the importance and higher cost of most main span components.

The preferred method is to apportion the risk to each pier and span component on the basis of its percentage value to the replacement cost of the structure in the central analysis area.

3.14.5.1—Vessel Frequency Distribution

The number of vessels, N , based on size, type, and loading condition and available water depth shall be developed for each pier and span component to be evaluated. Depending on waterway conditions, a differentiation between the number and loading condition of vessels transiting inbound and outbound shall be considered.

C3.14.5.1

In developing the design vessel distribution, the Designer should first establish the number and characteristics of the vessels using the navigable waterway or channel under the bridge. Because the water depth limits the size of vessel that could strike a bridge component, the navigable channel vessel frequency data can be modified, as required, on the basis of the water depth at each bridge component to determine the number and characteristics of the vessels that could strike the pier or span component being analyzed. Thus, each component could have a different value of N .

Vessel characteristics necessary to conduct the analysis include:

- Type, i.e., ship or barge;
- Size based on the vessel's deadweight tonnage, DWT ;
- Inbound and outbound operating characteristics;
- Loading condition, i.e., loaded, partly loaded, ballasted, or empty;
- Length overall, LOA ;
- Width or beam, B_M ;
- Draft associated with each loading condition;
- Bow depth, D_B ;
- Bow shape;
- Displacement tonnage, W ;
- Vertical clearances; and
- Number of transits under the bridge each year.

Sources for the vessel data and typical ship and barge characteristics are included in the AASHTO *Guide Specifications and Commentary for Vessel Collision Design of Highway Bridges* (2009).

The Designer should use judgment in developing a distribution of the vessel frequency data based on discrete groupings or categories of vessel size by DWT . It is recommended that the DWT intervals used in developing the vessel distribution not exceed 20,000 DWT for vessels smaller than 100,000 DWT , and not exceeding 50,000 DWT for ships larger than 100,000 DWT .

3.14.5.2—Probability of Aberrancy

3.14.5.2.1—General

The probability of vessel aberrancy, PA , may be determined by the statistical or the approximate method.

3.14.5.2.2—Statistical Method

The probability of aberrancy may be computed on the basis of a statistical analysis of historical data on vessel collisions, ramblings, and groundings in the waterway and on the number of vessels transiting the waterway during the period of accident reporting.

3.14.5.2.3—Approximate Method

The probability of aberrancy may be taken as:

$$PA = (BR)(R_B)(R_C)(R_{XC})(R_D) \quad (3.14.5.2.3-1)$$

where:

- PA = probability of aberrancy
- BR = aberrancy base rate
- R_B = correction factor for bridge location
- R_C = correction factor for current acting parallel to vessel transit path
- R_{XC} = correction factor for cross-currents acting perpendicular to vessel transit path
- R_D = correction factor for vessel traffic density

The base rate, BR , of aberrancy shall be taken as:

- For ships:

$$BR = 0.6 \times 10^{-4}$$

C3.14.5.2.1

The probability of aberrancy is mainly related to the navigation conditions at the bridge site. Vessel traffic regulations, vessel traffic management systems and aids to navigation can improve the navigation conditions and reduce the probability of aberrancy.

The probability of aberrancy, PA , sometimes referred to as the causation probability, is a measure of the risk that a vessel is in trouble as a result of pilot error, adverse environmental conditions, or mechanical failure.

An evaluation of accident statistics indicates that human error and adverse environmental conditions, not mechanical failures, are the primary reasons for accidents. In the United States, an estimated 60 percent to 85 percent of all vessel accidents have been attributed to human error.

C3.14.5.2.2

The most accurate procedure for determining PA is to compute it using long-term vessel accident statistics in the waterway and data on the frequency of ship/barge traffic in the waterway during the same period of time (*Larsen 1983*). Data from ship simulation studies and radar analysis of vessel movements in the waterway have also been used to estimate PA . Based on historical data, it has been determined that the aberrancy rate for barges is usually two to three times that measured for ships in the same waterway.

C3.14.5.2.3

Because the determination of PA based on actual accident data in the waterway is often a difficult and time-consuming process, an alternative method for estimating PA was established during the development of the *AASHTO Guide Specification on Vessel Collision Design of Highway Bridges*. The equations in this Article are empirical relationships based on historical accident data. The predicted PA value using these equations and the values determined from accident statistics are generally in agreement, although exceptions do occur.

It should be noted that the procedure for computing PA using Eq. 3.14.5.2.3-1 should not be considered to be either rigorous or exhaustive. Several influences, such as wind, visibility conditions, navigation aids, pilotage, etc., were not directly included in the method because their effects were difficult to quantify. These influences have been indirectly included because the empirical equations were developed from accident data in which these factors had a part.

It is anticipated that future research will provide a better understanding of the probability of aberrancy and

- For barges:

$$BR = 1.2 \times 10^{-4}$$

The correction factor for bridge location, R_B , based on the relative location of the bridge in either of three waterway regions, as shown in Figure 3.14.5.2.3-1, shall be taken as:

- For straight regions:

$$R_B = 1.0 \quad (3.14.5.2.3-2)$$

- For transition regions:

$$R_B = \left(1 + \frac{\theta}{90^\circ} \right) \quad (3.14.5.2.3-3)$$

- For turn/bend regions:

$$R_B = \left(1 + \frac{\theta}{45^\circ} \right) \quad (3.14.5.2.3-4)$$

where:

θ = angle of the turn or bend specified in Figure 3.14.5.2.3-1 (degrees)

The correction factor, R_C , for currents acting parallel to the vessel transit path in the waterway shall be taken as:

$$R_C = \left(1 + \frac{V_C}{10} \right) \quad (3.14.5.2.3-5)$$

where:

V_C = current velocity component parallel to the vessel transit path (knots)

The correction factor, R_{XC} , for cross-currents acting perpendicular to the vessel transit path in the waterway shall be taken as:

$$R_{XC} = (1 + V_{XC}) \quad (3.14.5.2.3-6)$$

where:

V_{XC} = current velocity component perpendicular to the vessel transit path (knots)

how to accurately estimate its value. The implementation of advanced vessel traffic control systems using automated surveillance and warning technology should significantly reduce the probability of aberrancy in navigable waterways.

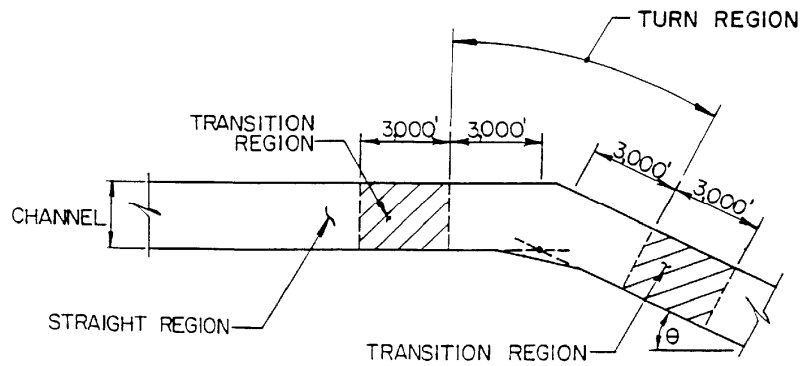

a. Turn in Channel

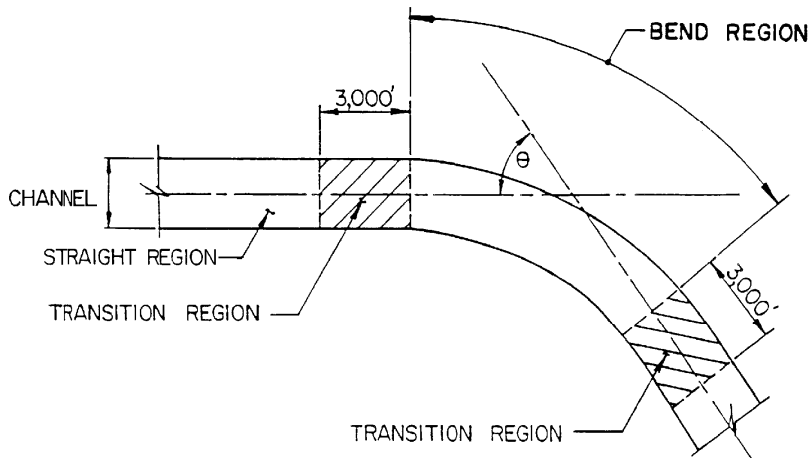

b. Bend in Channel

Figure 3.14.5.2.3-1—Waterway Regions for Bridge Location

The correction factor for vessel traffic density, R_D , shall be selected on the basis of the ship/barge traffic density level in the waterway in the immediate vicinity of the bridge defined as:

- Low density—vessels rarely meet, pass, or overtake each other in the immediate vicinity of the bridge:

$$R_D = 1.0 \quad (3.14.5.2.3-7)$$

- Average density—vessels occasionally meet, pass, or overtake each other in the immediate vicinity of the bridge:

$$R_D = 1.3 \quad (3.14.5.2.3-8)$$

- High density—vessels routinely meet, pass, or overtake each other in the immediate vicinity of the bridge:

$$R_D = 1.6 \quad (3.14.5.2.3-9)$$

3.14.5.3—Geometric Probability

C3.14.5.3

A normal distribution may be utilized to model the sailing path of an aberrant vessel near the bridge. The geometric probability, PG , shall be taken as the area under the normal distribution bounded by the pier width and the width of the vessel on each side of the pier, as specified in Figure 3.14.5.3-1. The standard deviation, σ , of the normal distribution shall be assumed to be equal to the length overall, LOA , of the design vessel selected in accordance with Article 3.14.4.

The location of the mean of the standard distribution shall be taken at the centerline of the vessel transit path. PG shall be determined based on the width, B_M , of each vessel classification category, or it may be determined for all classification intervals using the B_M of the design vessel selected in accordance with Article 3.14.4.

The geometric probability, PG , is defined as the conditional probability that a vessel will hit a bridge pier or superstructure component, given that it has lost control, i.e., it is aberrant, in the vicinity of the bridge. The probability of occurrence depends on the following factors:

- Geometry of waterway;
- Water depths of waterway;
- Location of bridge piers;
- Span clearances;
- Sailing path of vessel;
- Maneuvering characteristics of vessel;
- Location, heading, and velocity of vessel;
- Rudder angle at time of failure;
- Environmental conditions;
- Width, length, and shape of vessel; and
- Vessel draft.

The horizontal clearance of the navigation span has a significant impact on the risk of vessel collision with the main piers. Analysis of past collision accidents has shown that fixed bridges with a main span less than two to three times the design vessel length or less than two times the channel width are particularly vulnerable to vessel collision.

Various geometric probability models, some based on simulation studies, have been recommended and used on different bridge projects and for the development of general design provisions. Descriptions of these models may be found in IABSE (1983), Modjeski and Masters (1984), Prucz (1987), and Larsen (1993). The method used to determine PG herein is similar to that proposed by Knott et al. (1985). The use of a normal distribution is based on historical ship/bridge accident data. It is recommended that $\sigma = LOA$ of the design vessel for computing PG , and that bridge components located beyond 3σ from the centerline of the vessel transit path not be included in the analysis, other than the minimum impact requirement of Article 3.14.1.

The accident data used to develop the PG methodology primarily represents ships. Although barge accidents occur relatively frequently in United States waterways, there have been little published research findings concerning the distribution of barge accidents over a waterway. Until such data and research become available, it is recommended that the same $\sigma = LOA$ developed for ships be applied to barges with the barge LOA equal to the total length of the barge tow, including the towboat.

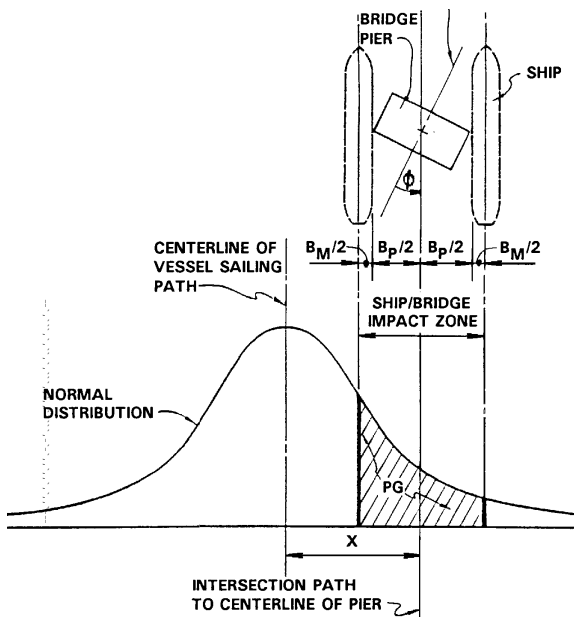

Figure 3.14.5.3-1—Geometric Probability of Pier Collision

3.14.5.4—Probability of Collapse

The probability of bridge collapse, PC , based on the ratio of the ultimate lateral resistance of the pier, H_p , and span, H_s , to the vessel impact force, P , shall be taken as:

- If $0.0 \leq H/P < 0.1$, then

$$PC = 0.1 + 9 \left(0.1 - \frac{H}{P} \right) \quad (3.14.5.4-1)$$

- If $0.1 \leq H/P < 1.0$, then

$$PC = 0.111 \left(1 - \frac{H}{P} \right) \quad (3.14.5.4-2)$$

- If $H/P \geq 1.0$, then

$$PC = 0.0 \quad (3.14.5.4-3)$$

where:

PC = probability of collapse

H = resistance of bridge component to a horizontal force expressed as pier resistance, H_p , or superstructure resistance, H_s , (kip)

P = vessel impact force, P_s , P_{BH} , P_{DH} , or P_{MT} , specified in Articles 3.14.8, 3.14.10.1, 3.14.10.2, and 3.14.10.3, respectively (kip)

3.14.5.5 Protection Factor

The protection factor, PF , shall be computed as:

$$PF = 1 - (\% \text{ Protection Provided}/100) \quad (3.14.5.5-1)$$

If no protection of the pier exists, then $PF = 1.0$. If the pier is 100 percent protected, then $PF = 0.0$. If the pier protection (for example, a dolphin system) provides 70 percent protection, then PF would be equal to 0.3. Values for PF may vary from pier to pier and may vary depending on the

C3.14.5.4

The probability that the bridge will collapse once it has been struck by an aberrant vessel, PC , is complex and is a function of the vessel size, type, configuration, speed, direction, and mass. It is also dependent on the nature of the collision and stiffness/strength characteristic of the bridge pier and superstructure to resist the collision impact loads.

The methodology for estimating PC was developed by Cowiconsult (1987) from studies performed by Fujii and Shiobara (1978) using Japanese historical damage data on vessels colliding at sea. The damage to bridge piers is based on ship damage data because accurate damage data for collision with bridges is relatively scarce.

Figure C3.14.5.4-1 is a plot of the probability of collapse relationships. From this figure, the following results are evident:

- Where the pier or superstructure impact resistance exceeds the vessel collision impact force of the design vessel, the bridge collapse probability becomes 0.0.
- Where the pier or superstructure impact resistance is in the range 10–100 percent of the collision force of the design vessel, the bridge collapse probability varies linearly between 0.0 and 0.10.
- Where the pier or superstructure impact resistance is below ten percent of the collision force, the bridge collapse probability varies linearly between 0.10 and 1.0.

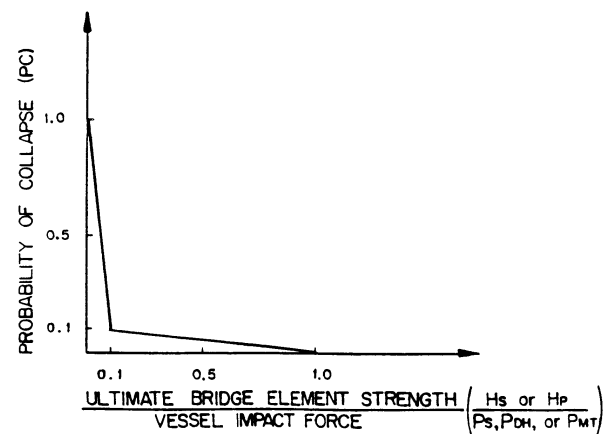

Figure C3.14.5.4-1—Probability of Collapse Distribution

C3.14.5.5

The purpose of the protection factor, PF , is to adjust the annual frequency of collapse, AF , for full or partial protection of selected bridge piers from vessel collisions such as:

- Dolphins, islands, etc.,
- Existing site conditions such as a parallel bridge protecting a bridge from impacts in one direction,

direction of the vessel traffic (i.e., vessel traffic moving inbound versus traffic moving outbound).

- A feature of the waterway (such as a peninsula extending out on one side of the bridge) that may block vessels from hitting bridge piers, or
- A wharf structure near the bridge that may block vessels from a certain direction.

The recommended procedure for estimating values for PF is shown in Figure C3.14.5.5-1. It illustrates a simple model developed to estimate the effectiveness of dolphin protection on a bridge pier.

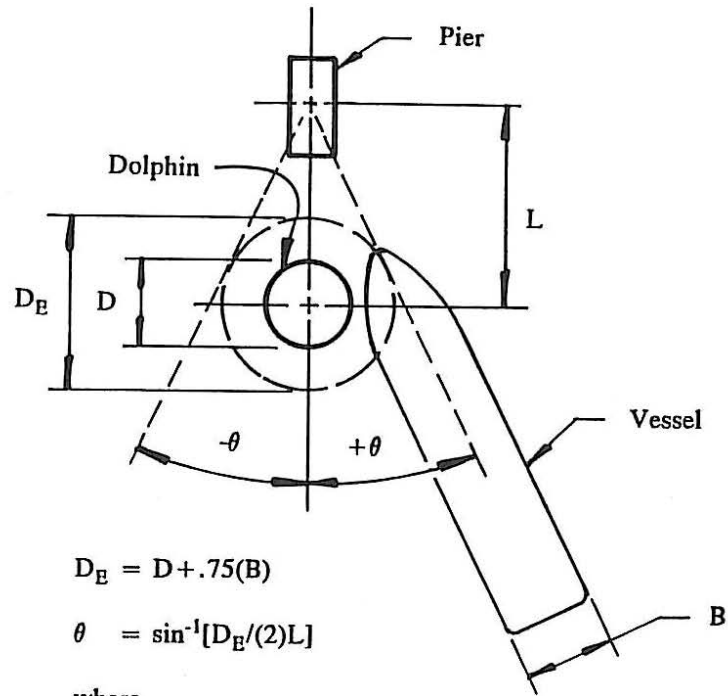

$$D_E = D + .75(B)$$

$$\theta = \sin^{-1}[D_E/(2)L]$$

where,

- θ = Protection angle provided by dolphin
- D = Diameter of dolphin (ft)
- B = Beam (width) of vessel (ft)
- L = Distance of dolphin from pier (ft)
- D_E = Effective dolphin diameter (ft)

a. Plan of Dolphin Protection.

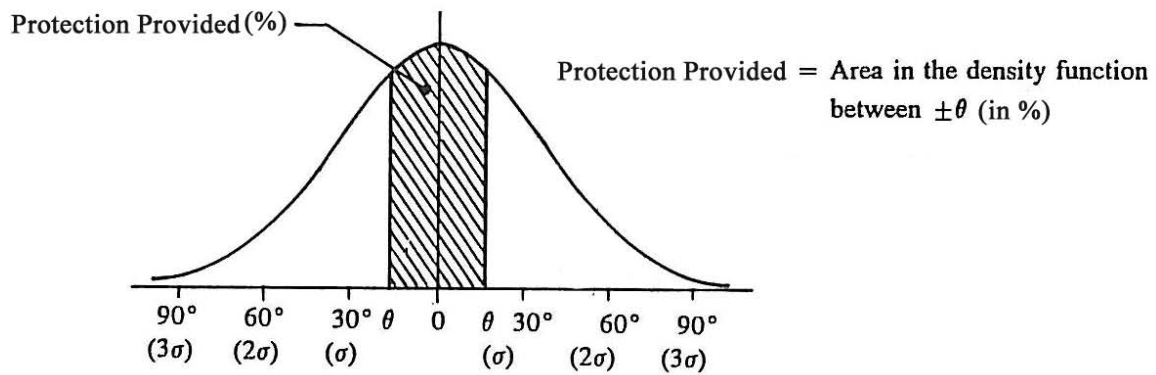

b. Normal Distribution of Vessel Collision Trajectories Around Bridge Pier (σ assumed = 30°).

Figure C3.14.5.5-1—Illustrative Model of the Protection Factor (PF) of Dolphin Protection around a Bridge Pier

3.14.6—Design Collision Velocity

The design collision velocity may be determined as specified in Figure 3.14.6-1, for which:

- V = design impact velocity (ft/s)
- V_T = typical vessel transit velocity in the channel under normal environmental conditions but not taken to be less than V_{MIN} (ft/s)
- V_{MIN} = minimum design impact velocity taken as not less than the yearly mean current velocity for the bridge location (ft/s)
- X = distance to face of pier from centerline of channel (ft)
- X_C = distance to edge of channel (ft)
- X_L = distance equal to 3.0 times the length overall of the design vessel (ft)

The length overall, *LOA*, for barge tows shall be taken as the total length of the tow plus the length of the tug/tow boat.

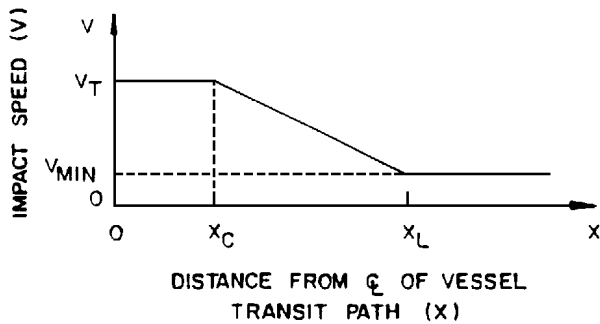

Figure 3.14.6-1—Design Collision Velocity Distribution

3.14.7—Vessel Collision Energy

The kinetic energy of a moving vessel to be absorbed during a noncentric collision with a bridge pier shall be taken as:

$$KE = \frac{C_H W V^2}{29.2} \tag{3.14.7-1}$$

where:

- KE = vessel collision energy (kip-ft)
- W = vessel displacement tonnage (tonne)

C3.14.6

A triangular distribution of collision impact velocity across the length of the bridge and centered on the centerline of the vessel transit path in the channel was based on historical accident data. This data indicated that aberrant ships and barges that collide with bridge piers further away from the channel are moving at reduced velocities compared with those hitting piers located closer to the navigable channel limits. Aberrant vessels located at long distances from the channel are usually drifting with the current. Aberrant vessels, located very near the channel, are moving at velocities approaching that of ships and barges in the main navigation channel.

The exact distribution of the velocity reduction is unknown. However, a triangular distribution was chosen because of its simplicity as well as its reasonableness in modeling the aberrant vessel velocity situation. The use of the distance 3.0 times *LOA* in Figure 3.14.6-1 to define the limits at which the design velocity becomes equal to that of the water current was based on the observation that very few accidents, other than with drifting vessels, have historically occurred beyond that boundary.

The selection of the design collision velocity is one of the most significant design parameters associated with the vessel collision requirements. Judgment should be exercised in determining the appropriate design velocity for a vessel transiting the waterway. The chosen velocity should reflect the “typical” transit velocity of the design vessel under “typical” conditions of wind, current, visibility, opposing traffic, waterway geometry, etc. A different vessel velocity may be required for inbound vessels than for outbound vessels given the presence of currents that may exist in the waterway.

In waterways subject to seasonal flooding, consideration should be given to flood flow velocities in determining the minimum collision velocity.

In general, the design velocity should not be based on extreme values representing extreme events, such as exceptional flooding and other extreme environmental conditions. Vessels transiting under these conditions are not representative of the “annual average” situations reflecting the typical transit conditions.

C3.14.7

Eq. 3.14.7-1 is the standard $mV^2/2$ relationship for computing kinetic energy with conversion from mass to weight, conversion of units and incorporation of a hydrodynamic mass coefficient, C_H , to account for the influence of the surrounding water upon the moving vessel. Recommendations for estimating C_H for vessels moving in a forward direction were based on studies by Saul and Svensson (1980) and data published by PIANC (1984). It should be noted that these hydrodynamic mass coefficients are smaller than those normally used for ship berthing computations, in which a relatively large mass of water

C_H = hydrodynamic mass coefficient
 V = vessel impact velocity (ft/s)

moves with the vessel as it approaches a dock from a lateral, or broadside, direction.

The vessel displacement tonnage, W , shall be based upon the loading condition of the vessel and shall include the empty weight of the vessel, plus consideration of the weight of cargo, DWT , for loaded vessels, or the weight of water ballast for vessels transiting in an empty or lightly loaded condition. The displacement tonnage for barge tows shall be the sum of the displacement of the tug/tow vessel and the combined displacement of a row of barges in the length of the tow.

The hydrodynamic mass coefficient, C_H , shall be taken as:

- If underkeel clearance exceeds $0.5 \times$ draft:

$$C_H = 1.05 \quad (3.14.7-2)$$

- If underkeel clearance is less than $0.1 \times$ draft:

$$C_H = 1.25 \quad (3.14.7-3)$$

Values of C_H may be interpolated from the range shown above for intermediate values of underkeel clearance. The underkeel clearance shall be taken as the distance between the bottom of the vessel and the bottom of the waterway.

3.14.8—Ship Collision Force on Pier

The head-on ship collision impact force on a pier shall be taken as:

$$P_S = 8.15 V \sqrt{DWT} \quad (3.14.8-1)$$

where:

P_S = equivalent static vessel impact force (kip)
 DWT = deadweight tonnage of vessel (tonne)
 V = vessel impact velocity (ft/s)

C3.14.8

The determination of the impact load on a bridge structure during a ship collision is complex and depends on many factors as follows:

- Structural type and shape of the ship's bow,
- Degree of water ballast carried in the forepeak of the bow,
- Size and velocity of the ship,
- Geometry of the collision, and
- Geometry and strength characteristics of the pier.

Eq. 3.14.8-1 was developed from research conducted by Woisin (1976) in West Germany to generate collision data with a view to protecting the reactors of nuclear-powered ships from collisions with other ships. The ship collision data resulted from collision tests with physical ship models at scales of 1:12.0 and 1:7.5. Woisin's results have been found to be in good agreement with the results of research conducted by other ship collision investigators worldwide (IABSE, 1983).

Figure C3.14.8-1 indicates the scatter in Woisin's test data due to the various collision factors discussed herein, the triangular probability density function used to model the scatter, and the selection of a 70 percent fractile force for use as an equivalent static impact force for bridge design. Using a 70 percent fractile force for a given design

vessel, the number of smaller ships with a crushing strength greater than this force would be approximately equal to the number of larger ships with a crushing strength less than this force. Figure C3.14.8-2 indicates typical ship impact forces computed with Eq. 3.14.8-1.

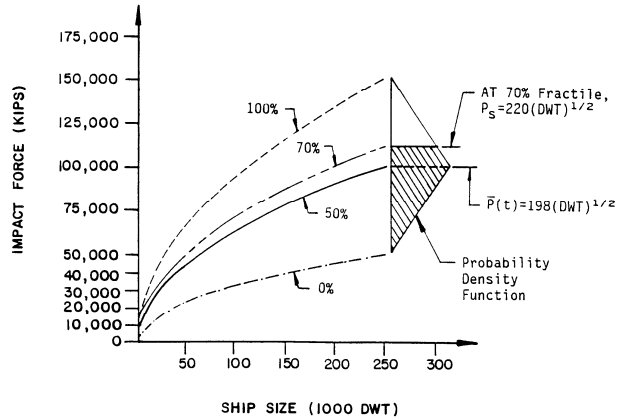

Figure C3.14.8-1—Probability Density Function of Ship Impact Force Data

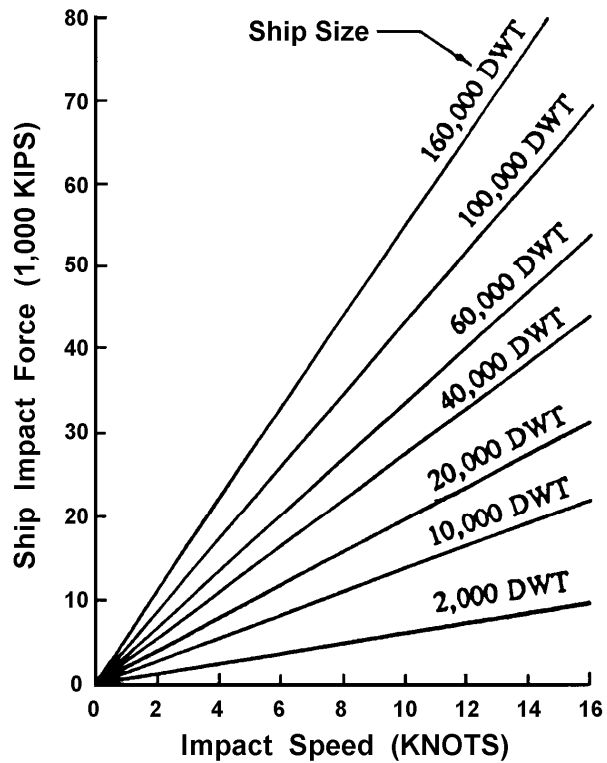

Figure C3.14.8-2—Typical Ship Impact Forces

3.14.9—Ship Bow Damage Length

The horizontal length of the ship's bow, crushed by impact with a rigid object, shall be taken as:

$$a_s = 1.54 \left(\frac{KE}{P_s} \right) \quad (3.14.9-1)$$

where:

- a_s = bow damage length of ship (ft)
 KE = vessel collision energy (kip-ft)
 P_s = ship impact force as specified in Eq. 3.14.8-1 (kip)

3.14.10—Ship Collision Force on Superstructure**3.14.10.1—Collision with Bow**

The bow collision impact force on a superstructure shall be taken as:

$$P_{BH} = (R_{BH})(P_s) \quad (3.14.10.1-1)$$

where:

- P_{BH} = ship bow impact force on an exposed superstructure (kip)
 R_{BH} = ratio of exposed superstructure depth to the total bow depth
 P_s = ship impact force specified in Eq. 3.14.8-1 (kip)

For the purpose of this Article, exposure is the vertical overlap between the vessel and the bridge superstructure with the depth of the impact zone.

3.14.10.2—Collision with Deck House

The deck house collision impact force on a superstructure shall be taken as:

$$P_{DH} = (R_{DH})(P_s) \quad (3.14.10.2-1)$$

where:

- P_{DH} = ship deck house impact force (kip)
 R_{DH} = reduction factor specified herein
 P_s = ship impact force as specified in Eq. 3.14.8-1 (kip)

For ships exceeding 100,000 tonne, R_{DH} shall be taken as 0.10. For ships smaller than 100,000 tonne:

C3.14.9

The average bow damage length, a , is computed based on the impact force averaged against the work path, $P(a)$, such that:

$$a = \frac{KE}{P(a)} \quad (C3.14.9-1)$$

The 1.54 coefficient used to compute the design ship damage depth in Eq. 3.14.9-1 results from the multiplication of the following factors:

- 1.25 to account for the increase in average impact force over time versus damage length,
- 1.11 to account for the increase in average impact force to the 70 percent design fractile, and
- 1.11 to provide an increase in the damage length to provide a similar level of design safety as that used to compute P_s .

C3.14.10.1

Limited data exists on the collision forces between ship bows and bridge superstructure components.

C3.14.10.2

According to the Great Belt Bridge investigation in Denmark (Cowiconsult, Inc., 1981) forces for deck house collision with a bridge superstructure:

P_{DH} = 1,200 kip for the deck house collision of a 1,000DWT freighter ship, and

P_{DH} = 6,000 kip for the deck house collision of a 100,000DWT tanker ship.

Based on these values, the approximate empirical relationship of Eq. 3.14.10.2-1 was developed for selecting superstructure design impact values for deck house collision.

$$R_{DH} = 0.2 - \left(\frac{DWT}{100,000} \right) (0.10) \quad (3.14.10.2-2)$$

3.14.10.3—Collision with Mast

The mast collision impact force on a superstructure shall be taken as:

$$P_{MT} = 0.10P_{DH} \quad (3.14.10.3-1)$$

where:

- P_{MT} = ship mast impact force (kip)
- P_{DH} = ship deck house impact force specified in Eq. 3.14.10.2-1 (kip)

3.14.11—Barge Collision Force on Pier

For the purpose of Article 3.14, the standard hopper barge shall be taken as an inland river barge with:

- width = 35.0 ft
- length = 195.0 ft
- depth = 12.0 ft
- empty draft = 1.7 ft
- loaded draft = 8.7 ft
- DWT = 1,700 tons

The collision impact force on a pier for a standard hopper barge shall be taken as:

- If $a_B < 0.34$ then:

$$P_B = 4,112a_B \quad (3.14.11-1)$$

- If $a_B \geq 0.34$ then:

$$P_B = 1,349 + 110a_B \quad (3.14.11-2)$$

where:

- P_B = equivalent static barge impact force (kip)
- a_B = barge bow damage length specified in Eq. 3.14.12-1 (ft)

C3.14.10.3

Eq. 3.14.10.3-1 was developed by estimating the impact forces based on bridge girder and superstructure damage from a limited number of mast impact accidents.

C3.14.11

There is less reported data on impact forces resulting from barge collisions than from ship collision. The barge collision impact forces determined by Eqs. 3.14.11-1 and 3.14.11-2 were developed from research conducted by Meir-Dornberg (1983) in West Germany. Meir-Dornberg's study included dynamic loading with a pendulum hammer on barge bottom models in scale 1:4.5, static loading on one bottom model in scale 1:6, and numerical analysis. The results for the standard European Barge, Type IIa, which has a similar bow to the standard hopper barge in the United States, are shown in Figure C3.14.11-1 for barge deformation and impact loading. No significant difference was found between the static and dynamic forces measured during the study. Typical barge tow impact forces using Eqs. 3.14.11-1 and 3.14.11-2 are shown in Figure C3.14.11-2.

where:

- E_B = deformation energy (kip-ft)
- \bar{P}_B = average equivalent static barge impact force resulting from the study (kip)

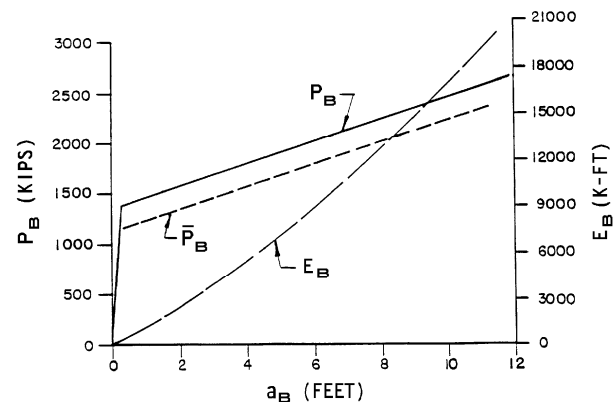

Figure C3.14.11-1—Barge Impact Force, Deformation Energy, and Damage Length Data

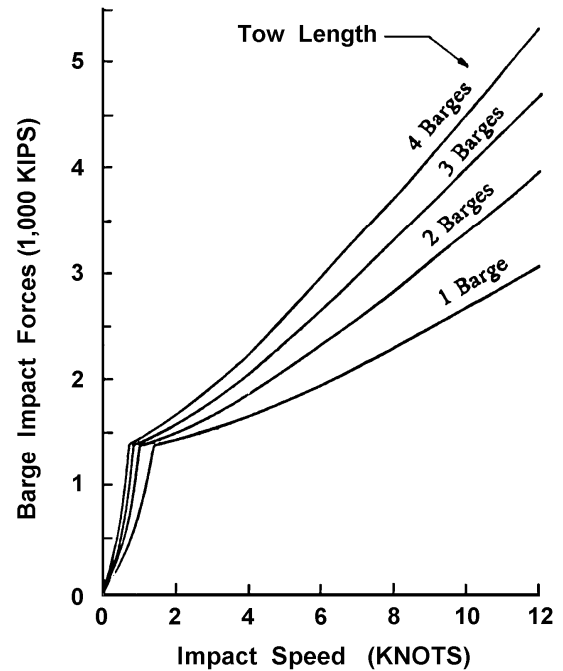

Figure C3.14.11-2—Typical Hopper Barge Impact Forces

Since the barge collision load formulation is for a standard rake head log height of 2.0 to 3.0 feet, the possibility of deeper head logs that may occur in tanker barges and special deck barges should also be considered. In lieu of better information, the barge force may be increased in proportion to the head log height compared to that of the standard hopper barge.

3.14.12—Barge Bow Damage Length

The barge bow horizontal damage length for a standard hopper barge shall be taken as:

$$a_B = 10.2 \left(\sqrt{1 + \frac{KE}{5,672}} - 1 \right) \quad (3.14.12-1)$$

where:

a_B = barge bow damage length (ft)
 KE = vessel collision energy (kip-ft)

3.14.13—Damage at the Extreme Limit State

Inelastic behavior and redistribution of force effects is permitted in substructure and superstructure components, provided that sufficient ductility and redundancy of the remaining structure exists in the extreme event limit state to prevent catastrophic superstructure collapse.

As an alternative, pier protection may be provided for the bridge structure to eliminate or reduce the vessel collision loads applied to the bridge structure to acceptable levels.

C3.14.12

The relationship for barge horizontal damage length, a_B , was developed from the same research conducted on barge collisions by Meir-Dornberg, as discussed in Article C3.14.11.

C3.14.13

Two basic protection options are available to the Bridge Designer. The first option involves designing the bridge to withstand the impact loads in either an elastic or inelastic manner. If the response to collision is inelastic, the design must incorporate redundancy or other means to prevent collapse of the superstructure.

The second option is to provide a protective system of fenders, pile-supported structures, dolphins, islands, etc., either to reduce the magnitude of the impact loads to less than the strength of the bridge pier or superstructure

components or to independently protect those components.

The requirements for either of these two options are general in nature because the actual design procedures that could be used vary considerably. This is particularly true for inelastic design. Because little information is available on the behavior of the inelastic deformation of materials and structures during the type of dynamic impacts associated with vessel impact, assumptions based on experience and sound engineering practice should be substituted.

3.14.14—Application of Impact Force

3.14.14.1—Substructure Design

For substructure design, equivalent static forces, parallel and normal to the centerline of the navigable channel, shall be applied separately as follows:

- 100 percent of the design impact force in a direction parallel to the alignment of the centerline of the navigable channel, or
- 50 percent of the design impact force in the direction normal to the direction of the centerline of the channel.

All components of the substructure, exposed to physical contact by any portion of the design vessel's hull or bow, shall be designed to resist the applied loads. The bow overhang, rake, or flair distance of ships and barges shall be considered in determining the portions of the substructure exposed to contact by the vessel. Crushing of the vessel's bow causing contact with any setback portion of the substructure shall also be considered.

The impact force in both design cases, specified herein, shall be applied to a substructure in accordance with the following criteria:

- For overall stability, the design impact force is applied as a concentrated force on the substructure at the mean high water level of the waterway, as shown in Figure 3.14.14.1-1, and
- For local collision forces, the design impact force is applied as a vertical line load equally distributed along the ship's bow depth, as shown in Figure 3.14.14.1-2. The ship's bow is considered to be raked forward in determining the potential contact area of the impact force on the substructure. For barge impact, the local collision force is taken as a vertical line load equally distributed on the depth of the head block, as shown in Figure 3.14.14.1-3.

C3.14.14.1

Two cases should be evaluated in designing the bridge substructure for vessel impact loadings:

- The overall stability of the substructure and foundation, assuming that the vessel impact acts as a concentrated force at the waterline, and
- The ability of each component of the substructure to withstand any local collision force resulting from a vessel impact.

The need to apply local collision forces on substructures exposed to contact by overhanging portions of a ship or barge's bow is well documented by accident case histories. The Sunshine Skyway Bridge in Tampa Bay, Florida, collapsed in 1980 as a result of the ship's bow impacting a pier column at a point 42.0 ft above the waterline. Ship and barge bow rake lengths are often large enough that they can even extend over protective fender systems and contact vulnerable bridge components, as shown in Figures C3.14.14.1-1 and C3.14.14.1-2. Bow shapes and dimensions vary widely, and the Designer may need to perform special studies to establish vessel bow geometry for a particular waterway location. Typical bow geometry data is provided in AASHTO (2009).

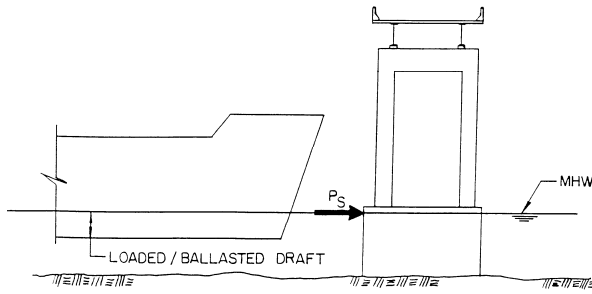

Figure 3.14.14.1-1—Ship Impact Concentrated Force on Pier

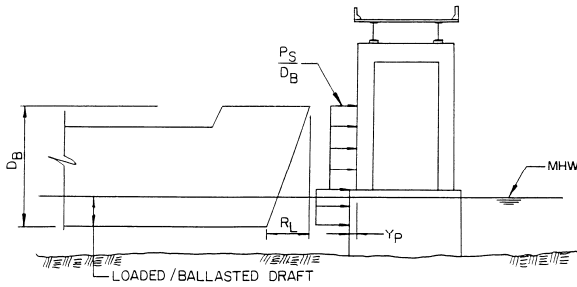

Figure 3.14.14.1-2—Ship Impact Line Load on Pier

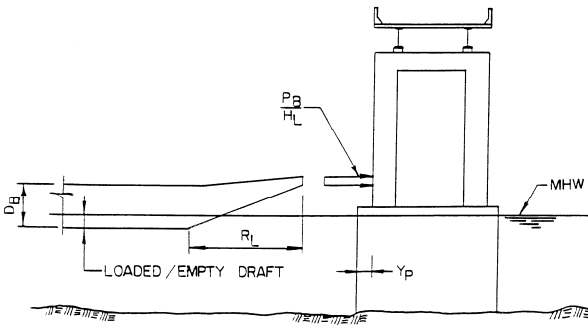

Figure 3.14.14.1-3—Barge Impact Force on Pier

3.14.14.2—Superstructure Design

For superstructure design, the design impact force shall be applied as an equivalent static force transverse to the superstructure component in a direction parallel to the alignment of the centerline of the navigable channel.

3.14.15—Protection of Substructures

Protection may be provided to reduce or to eliminate the exposure of bridge substructures to vessel collision by physical protection systems, including fenders, pile cluster, pile-supported structures, dolphins, islands, and combinations thereof.

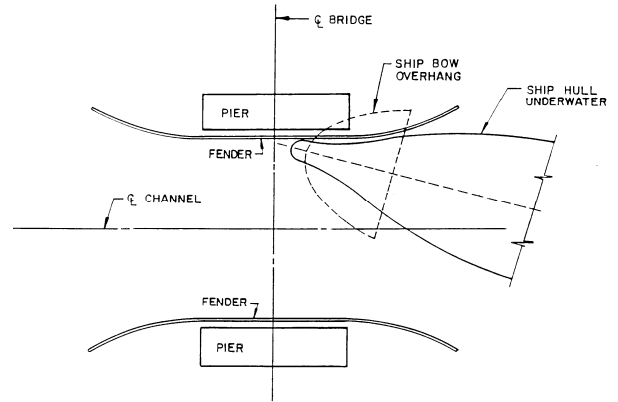

Figure C3.14.14.1-1—Plan of Ship Bow Overhang Impacting Pier

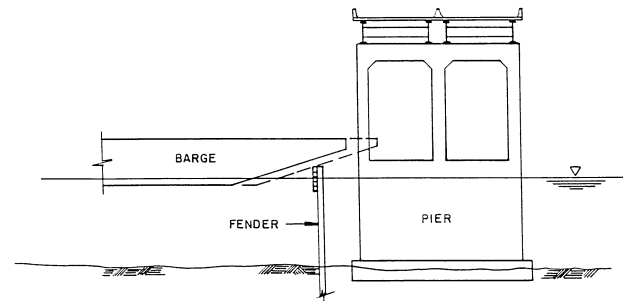

Figure C3.14.14.1-2—Elevation of Barge Bow Impacting Pier

C3.14.14.2

The ability of various portions of a ship or barge to impact a superstructure component depends on the available vertical clearance under the structure, the water depth, vessel-type and characteristics, and the loading condition of the vessel.

C3.14.15

The development of bridge protection alternatives for vessel collisions generally follows three approaches:

- Reducing the annual frequency of collision events, for example, by improving navigation aids near a bridge;

Severe damage and/or collapse of the protection system may be permitted, provided that the protection system stops the vessel prior to contact with the pier or redirects the vessel away from the pier.

- Reducing the probability of collapse, for example, by imposing vessel speed restrictions in the waterway; or
- Reducing the disruption costs of a collision, for example, by physical protection and motorist warning systems.

Because modifications to navigation aids in the waterway and vessel operating conditions are normally beyond the Bridge Designer's ability to implement, the primary area of bridge protection to be considered by the Designer are physical protection and motorist warning systems.

The current practice in the design of protective structures is almost invariably based on energy considerations. It is assumed that the loss of kinetic energy of the vessel is transformed into an equal amount of energy absorbed by the protective structure. The kinetic impact energy is dissipated by the work done by flexure, shear, torsion, and displacement of the components of the protective system.

Design of a protective system is usually an iterative process in which a trial configuration of a protective system is initially developed. For the trial, a force versus deflection diagram is developed via analysis or physical modeling and testing. The area under the diagram is the energy capacity of the protective system. The forces and energy capacity of the protective system is then compared with the design vessel impact force and energy to see if the vessel loads have been safely resisted.

3.14.16—Security Considerations

The Owner of the bridge shall establish the size and velocity of the vessel to be used in bridge security analysis.

The vessel impact force shall be determined in accordance with Articles 3.14.8, 3.14.10.1, 3.14.10.2, or 3.14.10.3, as applicable.

The probability of bridge collapse due to intentional collision with the design vessel at the design speed shall be taken equal to PC , which shall be determined using the provisions of Article 3.14.5.4. The design vessel and velocity are site-specific variables that should be selected by the Owner as part of a security assessment.

C3.14.16

As the intent of intentionally ramming a vessel into a bridge is to cause the bridge to collapse, the velocity of the vessel at the moment of collision is expected to be higher than the normal travel speed. In addition to accounting for the effects of impact, consideration should also be given to the potential for vessel-delivered explosives and subsequent fire. The physical limitations on the velocity and size of the vessel should be taken into account when determining the design velocity for intentional collision as well as the likely maximum explosive size that can be delivered. For example, the velocity of a barge tow is limited by the power of the tug boats and by the geometry of the waterway in the approach to the bridge. Similarly, the factors limiting the size of the vessel should be considered when determining the design vessel.

In case of accidental collision, determining the annual probability of collapse using Eq. 3.14.5-1 involves the annual number of vessels, N , the probability of vessel aberrancy, PA , and the geometric probability of a collision, PG . In the case of intentional collision, the value of each of the three variables may be taken as 1.0. Therefore, the probability of collapse in case of intentional collision is taken equal to PC .

3.15—BLAST LOADING: BL

3.15.1—Introduction

Where it has been determined that a bridge or a bridge component should be designed for intentional or unintentional blast force, the following should be considered:

- Size of explosive charge,
- Shape of explosive charge,
- Type of explosive,
- Stand-off distance,
- Location of the charge,
- Possible modes of delivery and associated capacities (e.g., maximum charge weight will depend upon vehicle type and can include cars, trucks, ships, etc.), and
- Fragmentation associated with vehicle-delivered explosives.

C3.15.1

The size, shape, location, and type of an explosive charge determine the intensity of the blast force produced by an explosion. For comparison purposes, all explosive charges are typically converted to their equivalent TNT charge weights.

Stand-off refers to the distance between the center of an explosive charge and a target. Due to the dispersion of blast waves in the atmosphere, increasing stand-off causes the peak pressure on a target to drop as a cubic function of the distance (i.e., for a given quantity of explosives, doubling the stand-off distance causes the peak pressure to drop by a factor of eight). The location of the charge determines the amplifying effects of the blast wave reflecting from the ground surface or from the surfaces of surrounding structural elements. The location of the charge also determines the severity of damage caused by fragments from the components closest to the blast traveling away from the blast center.

Information on the analysis of blast loads and their effects on structures may be found in J. M. Biggs (1964), W. E. Baker, et al. (1983), Department of the Army (1990), P. S. Bulson (1997), and Department of the Army (1986).

3.16—REFERENCES

AASHTO. 1989 with 1992 and 2002 interims. *Guide Specifications for Structural Design of Sound Barriers*. American Association of State Highway and Transportation Officials, Washington, DC.

AASHTO. 1991. *Guide Specification and Commentary for Vessel Collision Design of Highway Bridges*, First Edition. American Association of State Highway and Transportation Officials, Washington, DC.

AASHTO. 2002. *Standard Specifications for Highway Bridges*, 17th Edition, HB-17. American Association of State Highway and Transportation Officials, Washington, DC.

AASHTO. 2009 with 2010 interim. *Guide Specifications and Commentary for Vessel Collision Design of Highway Bridges*, Second Edition, GVCB-2-M. American Association of State Highway and Transportation Officials, Washington, DC.

AASHTO. 2009. *LRFD Guide Specifications for Design of Pedestrian Bridges*, Second Edition, GSDPB-2. American Association of State Highway and Transportation Officials, Washington, DC.

AASHTO. 2011. *AASHTO Guide Specifications for LRFD Seismic Bridge Design*, Second Edition, LRFDSEIS-2. American Association of State Highway and Transportation Officials, Washington, DC.

AASHTO. 2011. *A Policy on Geometric Design of Highways and Streets*, GDHS-6. American Association of State Highway and Transportation Officials, Washington, DC.

Afanas'ev, V. P., Y. V. Dolgoplov, and I. Shyaishtein. 1971. "Ice Pressure on Individual Marine Structures." In *Ice Physics and Ice Engineering*. G. N. Yakocev, ed. Translated from the Russian by Israel Program for Scientific Translations, Jerusalem, Israel.

Allen, T. M. 2005. *Development of Geotechnical Resistance Factors and Downdrag Load Factors for LRFD Foundation Strength Limit State Design*. Publication No. FHWA-NHI-05-052. Federal Highway Administration, Washington, DC.

Allen, T. M., A. Nowak, and R. Bathurst. 2005. *Calibration to Determine Load and Resistance Factors for Geotechnical and Structural Design*. TRB Circular E-C079, Transportation Research Board, Washington, DC.

ASCE. 1980. "Loads and Forces on Bridges." *Preprint 80-173*. American Society of Civil Engineers National Convention, Portland, OR, April 14–18, 1980.

ASCE. 1988. *Minimum Design Loads for Building and Other Structures*, ASCE 7-88. American Society of Civil Engineers, New York, NY.

AUSTROADS. 1992. *Bridge Design Code*. Hay Market, Australia.

Briaud, J. and L. Tucker. 1993. *Downdrag on Bitumen-Coated Piles*, NCHRP 393/Project 24-05, Transportation Research Board, National Research Council, Washington, DC.

Burg, R. G. and A.E. Fiorato. 1999. "High-Strength Concrete in Massive Foundation Elements." *PCA Research and Development Bulletin RD117*. Portland Cement Association, Skokie, IL.

Burg, R. G. and B.W. Ost. 1992. "Engineering Properties of Commercially Available High-Strength Concretes." *PCA Research and Development Bulletin RD104T*. Portland Cement Association, Skokie, IL.

Buth, C. E, W. F. Williams, M. S. Brackin, D. Lord, S. R. Geedipally and A. Y. Abu-Odeh. 2010. "Analysis of Large Truck Collisions with Bridge Piers: Phase 1. Report of Guidelines for Designing Bridge Piers and Abutments for Vehicle Collisions," Texas Transportation Institute, Texas A&M University, College Station, TX.

Buth, C.E, M. S. Brackin, W. F. Williams, G. T. Fry, 2010. "Collision Loads on Bridge Piers: Phase 2. Report of Guidelines for Designing Bridge Piers and Abutments for Vehicle Collisions", Texas Transportation Institute, Texas A&M University, College Station, TX.

Caquot, A., and J. Kerisel. 1948. *Tables for the Calculation of Passive Pressure, Active Pressure and Bearing Capacity of Foundations*. Gauthier-Villars, Libraire du Bureau des Longitudes, de L'Ecole Polytechnique, Paris.

CBA/Buckland and Taylor. 1982. "Annacis Island Bridge." In Report No. 3, *Ship Collision Risk Analysis*. Prepared for the British Columbia Ministry of Transportation and Highways, July 1982.

Cheney, R. S. 1984. "Permanent Ground Anchors." FHWA-DP-68-1R Demonstration Project. FHWA, U.S. Department of Transportation, Washington, DC, p. 132.

Cheney, R. S. and R. Chassie. 2000. *Soils and Foundations Workshop Reference Manual*, NHI-00-045. National Highway Institute, Federal Highway Administration, U.S. Department of Transportation, Washington, DC.

Clausen, C. J. F., and S. Johansen. 1972. "Earth Pressures Measured Against a Section of a Basement Wall," *Proceedings, 5th European Conference on SMFE*. Madrid, Spain, pp. 515–516.

Clough, G. W., and J. M. Duncan. 1991. "Earth Pressures." *Foundation Engineering Handbook*, 2nd Edition. H. Y. Fang, ed. Van Nostrand Reinhold, New York, NY, Chap. 6.

Clough, G. W., and T. D. O'Rourke. 1990. "Construction-Induced Movements of In-Situ Walls." In *Proc., 1990 Specialty Conference on Design and Performance of Earth Retaining Structures*. Ithaca, NY, pp. 439–470.

Clough, G. W., and Y. Tsui. 1974. "Performance of Tied-Back Retaining Walls." *Journal of the Geotechnical Engineering Division*, American Society of Civil Engineers, New York, NY, Vol. 100, No. GT 12, pp. 1259–1273.

Coastal Engineering Research Center. 1984. *Shore Protection Manual*, 4th Edition. Coastal Engineering Research Center, Washington, DC.

Cohen, H. 1990. *Truck Weight Limits: Issues and Options*, Special Report 225. Transportation Research Board, National Research Council, Washington, DC.

- Connor, R. J. 2002. *A Comparison of the In-Service Response of an Orthotropic Steel Deck with Laboratory Studies and Design Assumptions*, Ph.D. dissertation. Department of Civil and Environmental Engineering, Lehigh University, Bethlehem, PA.
- Cowiconsult, Inc. 1981. *Sunshine Skyway Bridge Ship Collision Risk Assessment*. Prepared for Figg and Muller Engineers, Inc., Lyngby, Denmark, September 1981.
- Cowiconsult. 1987. "General Principles for Risk Evaluation of Ship Collisions, Strandings, and Contact Incidents." Technical note, January 1987.
- CSA. 2000. *Canadian Highway Bridge Design Code*, CAN/CSA-S6-00. Canadian Standards Association International, Section 3, Loads, Toronto, ON.
- CSA. 1988. *Design of Highway Bridges*, CAN/CSA-S6-88. Canadian Standards Association, Rexdale, ON.
- Csagoly, P. F., and Z. Knobel. 1981. *The 1979 Survey of Commercial Vehicle Weights in Ontario*. Ontario Ministry of Transportation and Communications, Toronto, ON.
- D'Appolonia, E. 1999. *Developing New AASHTO LRFD Specifications for Retaining Walls*, Report for NCHRP Project 20-7, Task 88, Transportation Research Board, National Research Council, Washington, DC.
- FHWA. 2001. "Highway Performance Concrete." Compact Disc, Federal Highway Administration, U.S. Department of Transportation, August 2001.
- FHWA. 2006. *Seismic Retrofitting Manual for Highway Structures, Part I—Bridges*, FHWA Publication No. FHWA-HRT-06-032. Federal Highway Administration, U.S. Department of Transportation, Washington, DC.
- Flaate, K. S. 1966. *Stresses and Movements in Connection with Braced Cuts in Sand and Clay*. Ph.D. Dissertation, University of Illinois, Urbana, IL.
- Fujii, Y. and R. Shiobara. 1978. "The Estimation of Losses Resulting from Marine Accidents." *Journal of Navigation*, Cambridge University Press, Cambridge, England, Vol. 31, No. 1.
- Gajer, R. B., and V. P. Wagh. 1994. "Bridge Design for Seismic Performance Category B: The Problem with Foundation Design," *Proceeding No. 11th International Bridge Conference*, Paper IBC-94-62, Pittsburgh, PA.
- Gerard, R., and S. J. Stanely. 1992. "Probability Analysis of Historical Ice Jam Data for a Complex Reach: A Case Study." *Canadian Journal of Civil Engineering*, NRC Research Press, Ottawa, ON.
- Hanna, T. H., and G. A. Matallana. 1970. "The Behavior of Tied-Back Retaining Walls." *Canadian Geotechnical Journal*, NRC Research Press, Ottawa, ON, Vol. 7, No. 4, pp. 372–396.
- Hannigan, P. J., G. G. Goble, G. Thendean, G. E. Likins, and F. Rausche. 2005. *Design and Construction of Driven Pile Foundations*, Vol. I and II. Federal Highway Administration Report No. FHWA-HI-05. Federal Highway Administration, Washington, DC.
- Haynes, F. D. 1995. *Bridge Pier Design for Ice Forces*. Ice Engineering, U.S. Army Cold Regions Research and Engineering Laboratory, Hanover, NH.
- Haynes, F. D. 1996. Private communications.
- Highway Engineering Division. 1991. *Ontario Highway Bridge Design Code*, 3rd Edition. Highway Engineering Division, Ministry of Transportation and Communications, Toronto, ON.
- Hirsch, T. J. 1989. *Analysis and Design of Metrorail-Railroad Barrier Systems*. Texas A&M University, College Station, TX.

- Holtz, R. D., and W. D. Kovacs. 1981. *An Introduction to Geotechnical Engineering*, Prentice-Hall, Inc., Englewood Cliffs, NJ.
- Huiskamp, W. J. 1983. *Ice Force Measurements on Bridge Piers, 1980–1982*, Report No. SWE 83-1. Alberta Research Council, Edmonton, AB.
- Imbsen, R. A., D. E. Vandershaf, R. A. Schamber, and R. V. Nutt. 1985. *Thermal Effects in Concrete Bridge Superstructures*, NCHRP Report 276. Transportation Research Board, National Research Council, Washington, DC.
- International Association of Bridge and Structural Engineers. 1983. “Ship Collision with Bridges and Offshore Structures.” In *International Association of Bridge and Structural Engineers Colloquium*, Copenhagen, Denmark. 3 vols.
- Ishihara, K. and M. Yoshimine. 1992. “Evaluation of Settlements in Sand Deposits Following Liquefaction during Earthquakes.” *Soils and Foundations*, JSSMFE, Vol. 32, No. 1, March, pp. 173–188.
- Kavazanjian, E., Jr., N. Matasovi , T. Hadj-Hamou, and P. J. Sabatini. 1997. *Design Guidance: Geotechnical Earthquake Engineering for Highways*. Geotechnical Engineering Circular No. 3, Report No. FHWA-SA-97-076. Federal Highway Administration, U.S. Department of Transportation, Washington, DC.
- Knott, J., D. Wood, and D. Bonyun. 1985. “Risk Analysis for Ship-Bridge Collisions.” *Fourth Symposium on Coastal and Ocean Management*. American Society of Civil Engineers, Baltimore, MD, July 30–August 2, 1985.
- Kulicki, J. M., and D. R. Mertz. 1991. “A New Live Load Model for Bridge Design.” In *Proc., 8th Annual International Bridge Conference*, June 1991, pp. 238–246.
- Kulicki, J. M. and D. Mertz. 2006. “Evolution of Vehicular Live Load Models During the Interstate Design Era and Beyond, in: 50 Years of Interstate Structures: Past, Present and Future”, *Transportation Research Circular*, E-C104, Transportation Research Board, National Research Council, Washington, DC.
- Larsen, D. D. 1983. “Ship Collision Risk Assessment for Bridges.” In Vol. 1, *International Association of Bridge and Structural Engineers Colloquium*. Copenhagen, Denmark, pp. 113–128.
- Larsen, O. D. 1993. “Ship Collision with Bridges—The Interaction Between Vessel Traffic and Bridge Structures.” *IABSE Structural Engineering Document 4*, IABSE-AIPC-IVBH, Z rich, Switzerland.
- Lipsett, A. W., and R. Gerard. 1980. *Field Measurement of Ice Forces on Bridge Piers 1973–1979*, Report SWE 80-3. Alberta Research Council, Edmonton, AB.
- Liu, H. 1991. *Wind Engineering: A Handbook for Structural Engineers*, Prentice Hall, Englewood Cliffs, NJ.
- Mander, J. B., M. J. N. Priestley, and R. Park. 1988. “Observed Stress-Strain Behavior of Confined Concrete.” *Journal of the Structural Division*, American Society of Civil Engineers, New York, NY, August 1988.
- Mander, J. B., M. J. N. Priestley, and R. Park. 1988. “Theoretical Stress-Strain Model for Confined Concrete.” *Journal of the Structural Division*, American Society of Civil Engineers, New York, NY, August 1988.
- MCEER/ATC. 2003. *Recommended LRFD Guidelines for the Seismic Design of Highway Bridges*, Special Publication No. MCEER-03-SP03. Multidisciplinary Center for Earthquake Engineering Research, Buffalo, NY.
- Meir-Dornberg, K. E. 1983. “Ship Collisions, Safety Zones, and Loading Assumptions for Structures on Inland Waterways.” *VDI-Berichte*, No. 496, pp. 1–9.
- Modjeski and Masters, Consulting Engineers. 1984. *Criteria for the Design of Bridge Piers with Respect to Vessel Collision in Louisiana Waterways*. Prepared for the Louisiana Department of Transportation and Development and the Federal Highway Administration, Harrisburg, PA, November 1984.

Montgomery, C. T., R. Gerard, W. J. Huiskamp, and R. W. Kornelsen. 1984. "Application of Ice Engineering to Bridge Design Standards." In *Proc., Cold Regions Engineering Specialty Conference*. Canadian Society for Civil Engineering, Montreal, QC, April 4–6, 1984, pp. 795–810.

Montgomery, C. J., R. Gerard, and A. W. Lipsett. 1980. "Dynamic Response of Bridge Piers to Ice Forces." *Canadian Journal of Civil Engineering*, NRC Research Press, Ottawa, ON, Vol. 7, No. 2, pp. 345–356.

Montgomery, C. J., and A. W. Lipsett. 1980. "Dynamic Tests and Analysis of a Massive Pier Subjected to Ice Forces." *Canadian Journal of Civil Engineering*, NRC Research Press, Ottawa, ON, Vol. 7, No. 3, pp. 432–441.

NCHRP. 2002. *Comprehensive Specification for the Seismic Design of Bridges*, NCHRP Report 472. Transportation Research Board, National Research Council, Washington, DC.

NCHRP. 2006. *Recommended LRFD Guidelines for the Seismic Design of Highway Bridges*, Draft Report NCHRP Project 20-07, Task 193. TRC Imbsen & Associates, Sacramento, CA.

NCHRP. 2009. *Updated Test and Design Methods for Thermoplastic Drainage Pipe*, NCHRP Report 631. National Cooperation Research Program, Transportation Research Board, National Research Council, Washington, DC. Prepared by T. J. McGrath, I. D. Moore, and G. Y. Hsuan.

Neill, C. R. 1976. "Dynamic Ice Forces on Piers and Piles: An Assessment of Design Guidelines in the Light of Recent Research." *Canadian Journal of Civil Engineering*, NRC Research Press, Ottawa, ON, Vol. 3, No. 2, pp. 305–341.

Neill, C. R., ed. 1981. *Ice Effects on Bridges*. Roads and Transportation Association of Canada, Ottawa, ON.

Nevel, D. E. 1972. "The Ultimate Failure of a Floating Ice Sheet." In *Proc., International Association for Hydraulic Research, Ice Symposium*, pp. 17–22.

Nicholson, P. J., D. D. Uranowski, and P. T. Wycliffe-Jones. 1981. *Permanent Ground Anchors: Nicholson Design Criteria*, FHWA/RD/81-151. Federal Highway Administration, U.S. Department of Transportation, Washington, DC, p. 151.

Nowak, A. S. 1992. *Calibration of LRFD Bridge Design Code*, NCHRP Project 12-33. University of Michigan, Ann Arbor, MI.

Nowak, A. S. 1995. "Calibration of LRFD Bridge Design Code." *Journal of Structural Engineering*, American Society of Civil Engineers, New York, NY, Vol. 121, No. 8, pp. 1245–1251.

Nowak, A. S. 1999. *Calibration of LRFD Bridge Design Code*. NCHRP Report 368, Transportation Research Board, National Research Council, Washington, DC.

O'Rourke, T. D. 1975. *A Study of Two Braced Excavations in Sand and Interbedded Stiff Clay*. Ph.D Dissertation, University of Illinois, Urbana, IL.

Page, J. 1976. *Dynamic Wheel Load Measurements on Motorway Bridges*. Transportation and Road Research Laboratory, Crowthorne, Berkshire, UK.

Paikowsky, S. G., with contributions from B. Birgisson, M. McVay, T. Nguyen, C. Kuo, G. Baecher, B. Ayyab, K. Stenersen, K. O'Malley, L. Chernauskas, and M. O'Neill. 2004. *Load and Resistance Factor Design (LRFD) for Deep Foundations*. NCHRP (Final) Report 507, Transportation Research Board, National Research Council, Washington, DC.

Peck, R. B., W. E. Hanson, and T. H. Thornburn. 1974. *Foundation Engineering*, 2nd Edition. John Wiley and Sons, Inc., New York, NY.

PIANC. 1984. *Report of the International Commission for Improving the Design of Fender Systems*. International Navigation Association, Brussels, Belgium.

Poulos, H. G., and E. H. Davis. 1974. *Elastic Solutions for Soil and Rock Mechanics*. John Wiley and Sons, Inc., New York, NY.

- Priestley, M. J. N., R. Parks, and R. T. Potangaroa. 1981. "Ductility of Spirally Confined Concrete Columns." *Journal of the Structural Division*, American Society of Civil Engineers, New York, NY, January 1981.
- Priestley, M. J. N., F. Seible and G. M. Calvi. 1996. *Seismic Design and Retrofit of Bridges*. John Wiley and Sons, Inc., New York, NY.
- Priestley, M. J. N., F. Seible, and Y. H. Chai. 1992. "Design Guidelines for Assessment Retrofit and Repair of Bridges for Seismic Performance." University of California, San Diego, CA.
- Prucz, Z., and W. B. Conway. 1987. "Design of Bridge Piers Against Ship Collision." *Bridges and Transmission Line Structures*. L. Tall, ed: American Society of Civil Engineers, New York, NY, pp. 209–223.
- Ritter, M. A. 1990. *Timber Bridges: Design, Construction, Inspection, and Maintenance*, EM7700-B. Forest Service, U.S. Department of Agriculture, Washington, DC.
- Roeder, C. W. 2002. *Thermal Design Procedure for Steel and Concrete Bridges*. Final Report for NCHRP 20-07/106. Transportation Research Board, National Research Council, Washington, D.C., April 2002.
- Rowe, W. D. 1977. *An Anatomy of Risk*. John Wiley and Sons, Inc., New York, NY.
- Sabatini, P. J., D. G. Pass, and R. C. Bachus. 1999. *Geotechnical Engineering Circular No. 4—Ground Anchors and Anchored Systems*, Federal Highway Administration, Report No. FHWA-SA-99-015. NTIS, Springfield, VA.
- Saul, R. and H. Svensson. 1980. "On the Theory of Ship Collision Against Bridge Piers." In *LABSE Proceedings*, February 1980, pp. 51–82.
- Schnabel, Jr., H. 1982. *Tiebacks in Foundation Engineering and Construction*. McGraw-Hill, New York, NY, p. 171.
- Sherif, M. A., I. Ishibashi, and C. D. Lee. 1982. "Earth Pressures Against Rigid Retaining Walls." *Journal of Geotechnical Engineering Division*, American Society of Civil Engineers, New York, NY, Vol. 108, GT5, pp. 679–695.
- Simiu, E. 1973. "Logarithmic Profiles and Design Wind Speeds." *Journal of the Mechanics Division*, American Society of Civil Engineers, New York, NY, Vol. 99, No. EM5, October 1973, pp. 1073–1083.
- Simiu, E. 1976. "Equivalent Static Wind Loads for Tall Building Design." *Journal of the Structures Division*, American Society of Civil Engineers, New York, NY, Vol. 102, No. ST4, April, 1976, pp. 719–737.
- Somerville, P.G. 1997. "The Characteristics and Quantification of Near Fault Ground Motion," *Proceedings of the FHWA/NCEER Workshop on the National Representation of Seismic Ground Motion for New and Existing Highway Facilities*. Center for Earthquake Engineering Research, Buffalo, NY, Technical Report 97-0010, State University of New York at Buffalo, pp. 1293–1318.
- Somerville, P. G., N. G. Smith, R. W. Graves, and N. A. Abrahamson. 1997. "Modification of Empirical Strong Ground Motion Attenuation Relations to Include the Amplitude and Duration Effects of Rupture Directivity," *Seismological Research Letters*, Vol. 68, pp. 199–222.
- Terzaghi, K. 1934. "Retaining Wall Design for Fifteen-Mile Falls Dam." *Engineering News Record*, May 1934, pp. 632–636.
- Terzaghi, K., and R. B. Peck. 1967. *Soil Mechanics in Engineering Practice*, 2nd Edition. John Wiley and Sons, Inc., New York, NY, p. 729.
- Tokimatsu, K. and B. Bolton Seed. 1987. Evaluation of Settlements in Sands due to Earthquake Shaking. *Journal of Geotechnical Engineering*. American Society of Civil Engineers, Vol. 113, No. 8, pp. 861–878.
- Transit New Zealand. 1991. *Bridge Manual: Design and Evaluation*. Draft. Transit New Zealand, Wellington, New Zealand.

U.S. Department of the Navy. 1982. *Foundations and Earth Structures*, Technical Report NAVFAC DM-7.1 and DM-7.2. Naval Facilities Command, U.S. Department of Defense, Washington, DC, p. 244.

U.S. Department of the Navy. 1982. "Soil Mechanics." *Design Manual 7.1*, NAVFAC DM-7.1. Naval Facilities Engineering Command, U.S. Department of Defense, Alexandria, VA, p. 348.

Whitman, R.V. 1984. "Evaluating Calculated Risk in Geotechnical Engineering." *Journal of Geotechnical Engineering*, American Society of Civil Engineers, New York, NY, Vol. 110, No. 2, February 1984, pp. 145–188.

Williams, G. P. 1963. "Probability Charts for Predicting Ice Thickness." *Engineering Journal*, June 1963, pp. 3–7.

Woisin, G. 1976. "The Collision Tests of the GKSS." In *Jahrbuch der Schiffbautechnischen Gesellschaft*, Vol. 70. Berlin, Germany, pp. 465–487.

Zabilansky, L. J. 1996. "Ice Force and Scour Instrumentation for the White River, Vermont." *Special Report 96-6*. U.S. Army Cold Regions Research and Engineering Laboratory, U.S. Department of Defense, Hanover, NH.

APPENDIX A3—SEISMIC DESIGN FLOWCHARTS

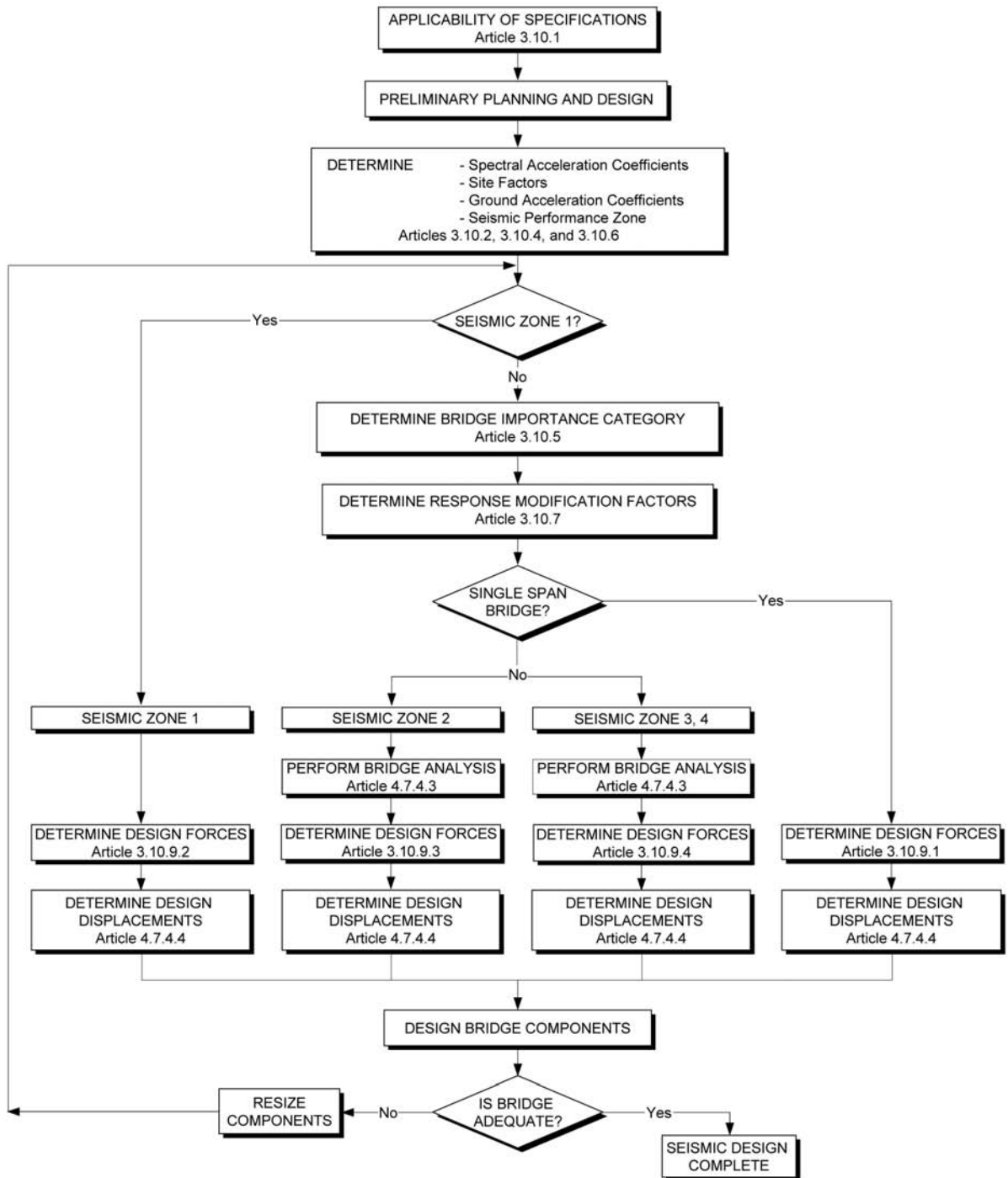

Figure A3-1—Seismic Design Procedure Flow Chart

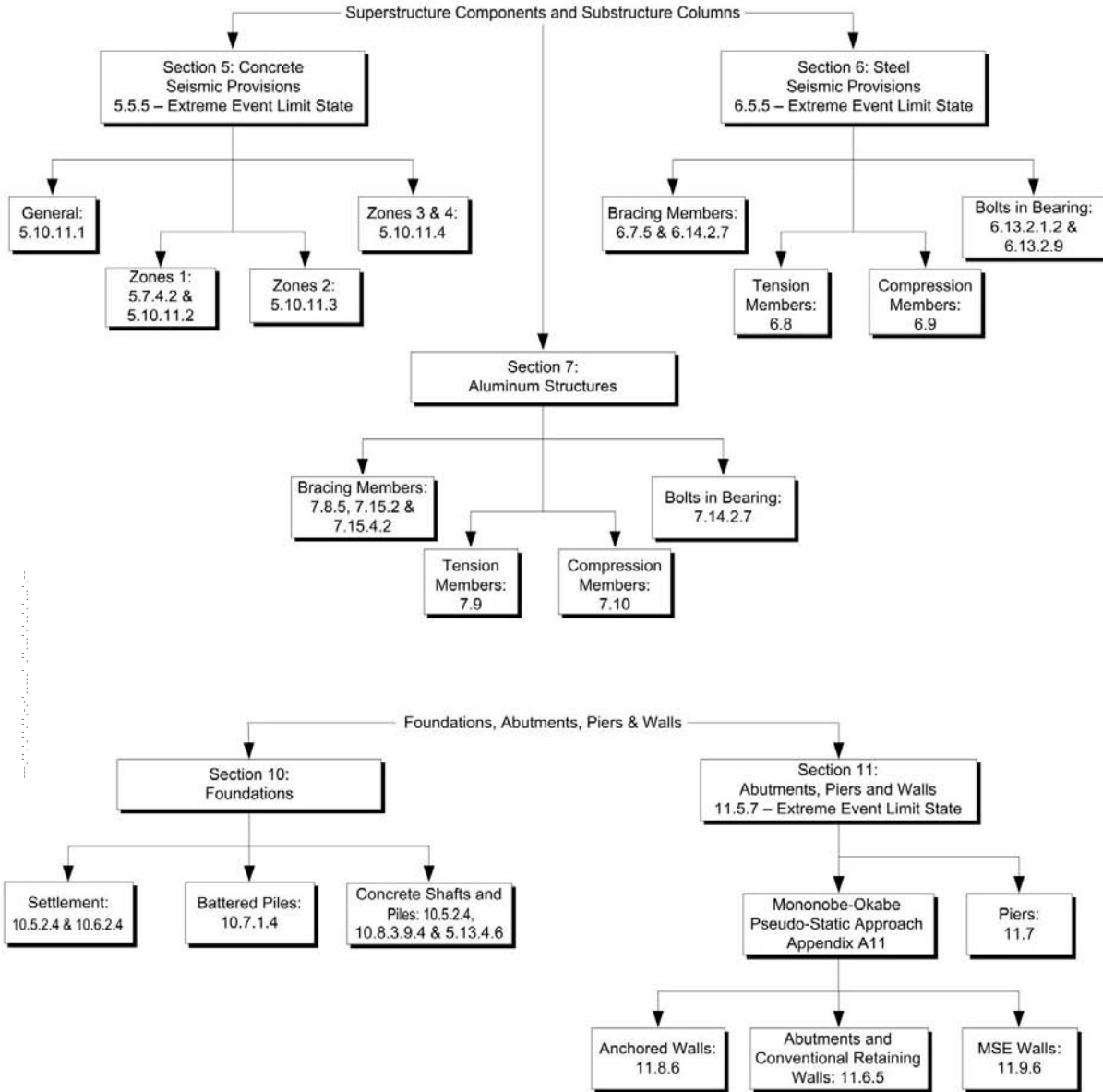

Figure A3-2—Seismic Detailing and Foundation Design Flow Chart

APPENDIX B3—OVERSTRENGTH RESISTANCE

Article 3.10.9.4.3a defines the forces resulting from plastic hinging, i.e., a column reaching its ultimate moment capacity, in the columns and presents two procedures. One is for a single column hinging about its two principal axes; this is also applicable for piers and bents acting as single columns. The other procedure is for a multiple column bent in the plane of the bent. The forces are based on the potential overstrength resistance of the materials, and to be valid the design detail requirements of this Section must be used so that plastic hinging of the columns can occur. The overstrength resistance results from actual properties being greater than the minimum specified values and is implemented by specifying resistance factors greater than unity. This fact must be accounted for when forces generated by yielding of the column are used as design forces. Generally, overstrength resistance depends on the following factors:

- The actual size of the column and the actual amount of reinforcing steel.
- The effect of an increased steel strength over the specified f_y and for strain hardening effects.
- The effect of an increased concrete strength over the specified f'_c and confinement provided by the transverse steel. Also, with time, concrete will gradually increase in strength.
- The effect of an actual concrete ultimate compressive strain above 0.003.

Column Size and Reinforcement Configuration

The design engineer should select the minimum column section size and steel reinforcement ratio when satisfying structural design requirements. As these parameters increase, the overstrength resistance increases. This may lead to an increase in the foundation size and cost. A size and reinforcement ratio which forces the design below the nose of the interaction curve is preferable, especially in high seismic areas. However, the selection of size and reinforcement must also satisfy architectural, and perhaps other requirements, which may govern the design.

Increase in Reinforcement Strength

Almost all reinforcing bars will have a yield strength larger than the minimum specified value which may be up to 30 percent higher, with an average increase of 12 percent. Combining this increase with the effect of strain hardening, it is realistic to assume an increased yield strength of $1.25 f_y$, when computing the column overstrength.

Increase in Concrete Strength

Concrete strength is defined as the specified 28-day compression strength; this is a low estimate of the strength expected in the field. Typically, conservative concrete batch designs result in actual 28-day strengths of about 20–25 percent higher than specified. Concrete will also continue to gain strength with age. Tests on cores taken from older California bridges built in the 1950s and 1960s have consistently yielded compression strength in excess of $1.5 f'_c$. Concrete compression strength is further enhanced by the possible confinement provided by the transverse reinforcement. Rapid loading due to seismic forces could also result in significant increase in strength, i.e., strain rate effect. In view of all the above, the actual concrete strength when a seismic event occurs is likely to significantly exceed the specified 28-day strength. Therefore, an increased concrete strength of $1.5 f'_c$ could be assumed in the calculation of the column overstrength resistance.

Ultimate Compressive Strain (ϵ_c)

Although tests on unconfined concrete show 0.003 to be a reasonable strain at first crushing, tests on confined column sections show a marked increase in this value. The use of such a low extreme fiber strain is a very conservative estimate of strains at which crushing and spalling first develop in most columns, and considerably less than the expected strain at maximum response to the design seismic event. Research has supported strains on the order of 0.01 and higher as the likely magnitude of ultimate compressive strain. Therefore, designers could assume a value of ultimate strain equal to 0.01 as a realistic value.

For calculation purposes, the thickness of clear concrete cover used to compute the section overstrength shall not be taken to be greater than 2.0 in. This reduced section shall be adequate for all applied loads associated with the plastic hinge.

Overstrength Capacity

The derivation of the column overstrength capacity is depicted in Figure B3-1. The effect of higher material properties than specified is illustrated by comparing the actual overstrength curve, computed with realistic f'_c, f_y , and ϵ_c values, to the nominal strength interaction curve, P_n, M_n . It is generally satisfactory to approximate the overstrength capacity curve by multiplying the nominal moment strength by the 1.3 factor for axial loads below the nose of the interaction curve, i.e., $P_n, 1.3 M_n$ curve. However, as shown, this curve may be in considerable error for axial loads above the nose of the interaction curve. Therefore, it is recommended that the approximate overstrength curve be obtained by multiplying both P_n and M_n by $\phi = 1.3$, i.e., $1.3 P_n, 1.3 M_n$. This curve follows the general shape of the actual curve very closely at all levels of axial loads.

In the light of the above discussion, it is recommended that:

- For all bridges with axial loads below P_b , the overstrength moment capacity shall be assumed to be 1.3 times the nominal moment capacity.
- For bridges in Zones 3 and 4 with operational classification of “other”, and for all bridges in Zone 2 for which plastic hinging has been invoked, the overstrength curve for axial loads greater than P_b shall be approximated by multiplying both P_n and M_n by $\phi = 1.3$.
- For bridges in Zones 3 and 4 with operational classification of “essential” or “critical”, the overstrength curve for axial loads greater than P_b shall be computed using realistic values for f'_c, f_y , and ϵ_c as recommended in Table B3-1 or from values based on actual test results. The column overstrength, thus calculated, should not be less than the value estimated by the approximate curve based on $1.3 P_n, 1.3 M_n$.

Table B3-1—Recommended Increased Values of Materials Properties

Increased f_y (minimum)	$1.25 f_y$
Increased f'_c	$1.5 f'_c$
Increased ϵ_c	0.01

Shear Failure

The shear mode of failure in a column or pile bent will probably result in a partial or total collapse of the bridge; therefore, the design shear force must be calculated conservatively. In calculating the column or pile bent shear force, consideration must be given to the potential locations of plastic hinges. For flared columns, these may occur at the top and bottom of the flare. For multiple column bents with a partial-height wall, the plastic hinges will probably occur at the top of the wall unless the wall is structurally separated from the column. For columns with deeply embedded foundations, the plastic hinge may occur above the foundation mat or pile cap. For pile bents, the plastic hinge may occur above the calculated point of fixity. Because of the consequences of a shear failure, it is recommended that conservatism be used in locating possible plastic hinges such that the smallest potential column length be used with the plastic moments to calculate the largest potential shear force for design.

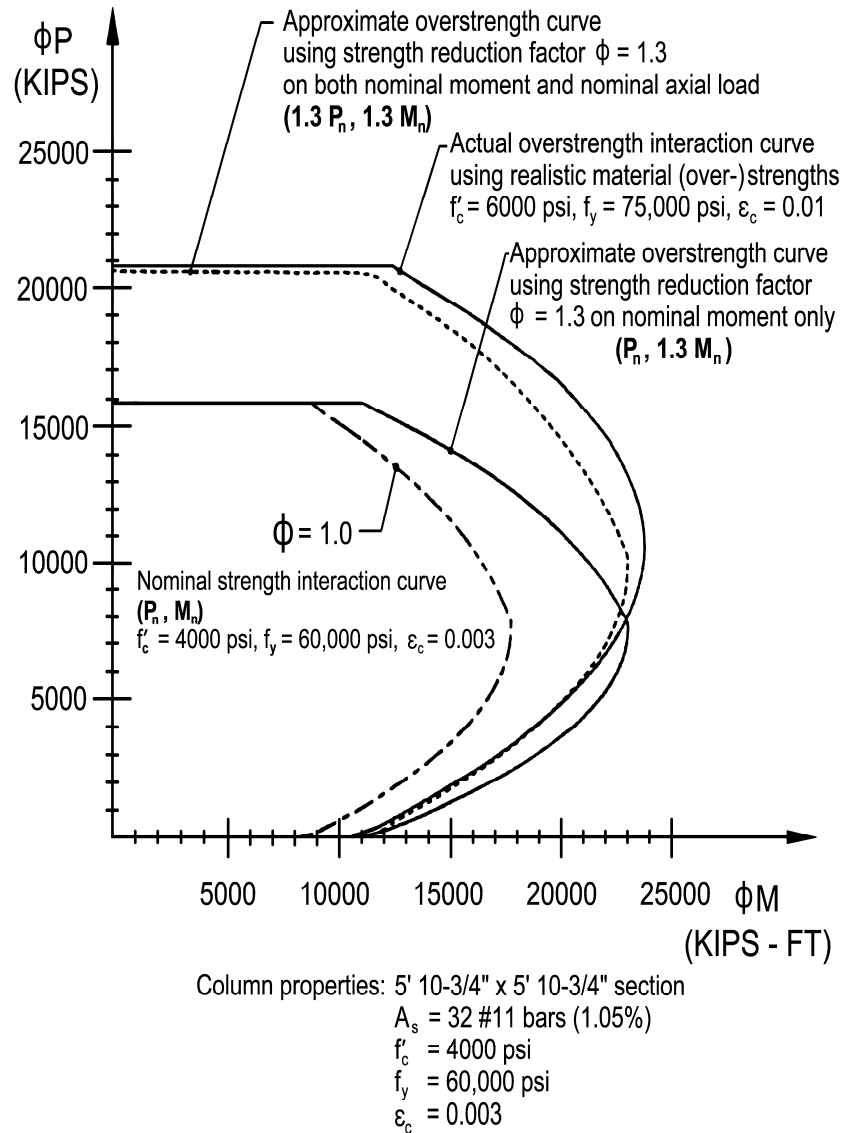

Figure B3-1—Development of Approximate Overstrength Interaction Curves from Nominal Strength Curves after Gajer and Wagh (1994)

SECTION 4: STRUCTURAL ANALYSIS AND EVALUATION

TABLE OF CONTENTS

4.1—SCOPE.....	4-1
4.2—DEFINITIONS.....	4-2
4.3—NOTATION.....	4-6
4.4—ACCEPTABLE METHODS OF STRUCTURAL ANALYSIS.....	4-9
4.5—MATHEMATICAL MODELING.....	4-10
4.5.1—General.....	4-10
4.5.2—Structural Material Behavior.....	4-11
4.5.2.1—Elastic Versus Inelastic Behavior.....	4-11
4.5.2.2—Elastic Behavior.....	4-11
4.5.2.3—Inelastic Behavior.....	4-11
4.5.3—Geometry.....	4-12
4.5.3.1—Small Deflection Theory.....	4-12
4.5.3.2—Large Deflection Theory.....	4-12
4.5.3.2.1—General.....	4-12
4.5.3.2.2—Approximate Methods.....	4-13
4.5.3.2.2a—General.....	4-13
4.5.3.2.2b—Moment Magnification—Beam Columns.....	4-14
4.5.3.2.2c—Moment Magnification—Arches.....	4-15
4.5.3.2.3—Refined Methods.....	4-16
4.5.4—Modeling Boundary Conditions.....	4-16
4.5.5—Equivalent Members.....	4-16
4.6—STATIC ANALYSIS.....	4-17
4.6.1—Influence of Plan Geometry.....	4-17
4.6.1.1—Plan Aspect Ratio.....	4-17
4.6.1.2—Structures Curved in Plan.....	4-17
4.6.1.2.1—General.....	4-17
4.6.1.2.2—Single-Girder Torsionally Stiff Superstructures.....	4-18
4.6.1.2.3—Concrete Box Girder Bridges.....	4-18
4.6.1.2.4—Steel Multiple-Beam Superstructures.....	4-20
4.6.1.2.4a—General.....	4-20
4.6.1.2.4b—I-Girders.....	4-20
4.6.1.2.4c—Closed Box and Tub Girders.....	4-21
4.6.2—Approximate Methods of Analysis.....	4-22
4.6.2.1—Decks.....	4-22
4.6.2.1.1—General.....	4-22
4.6.2.1.2—Applicability.....	4-22
4.6.2.1.3—Width of Equivalent Interior Strips.....	4-23
4.6.2.1.4—Width of Equivalent Strips at Edges of Slabs.....	4-25
4.6.2.1.4a—General.....	4-25
4.6.2.1.4b—Longitudinal Edges.....	4-25
4.6.2.1.4c—Transverse Edges.....	4-25

4.6.2.1.5—Distribution of Wheel Loads.....	4-26
4.6.2.1.6—Calculation of Force Effects	4-26
4.6.2.1.7—Cross-Sectional Frame Action	4-27
4.6.2.1.8—Live Load Force Effects for Fully and Partially Filled Grids and for Unfilled Grid Decks Composite with Reinforced Concrete Slabs	4-27
4.6.2.1.9—Inelastic Analysis	4-29
4.6.2.2—Beam-Slab Bridges	4-29
4.6.2.2.1—Application	4-29
4.6.2.2.2—Distribution Factor Method for Moment and Shear.....	4-35
4.6.2.2.2a—Interior Beams with Wood Decks	4-35
4.6.2.2.2b—Interior Beams with Concrete Decks	4-35
4.6.2.2.2c—Interior Beams with Corrugated Steel Decks	4-38
4.6.2.2.2d—Exterior Beams	4-39
4.6.2.2.2e—Skewed Bridges	4-40
4.6.2.2.2f—Flexural Moments and Shear in Transverse Floorbeams.....	4-41
4.6.2.2.3—Distribution Factor Method for Shear	4-42
4.6.2.2.3a—Interior Beams.....	4-42
4.6.2.2.3b—Exterior Beams	4-44
4.6.2.2.3c—Skewed Bridges	4-46
4.6.2.2.4—Curved Steel Bridges	4-46
4.6.2.2.5—Special Loads with Other Traffic.....	4-47
4.6.2.3—Equivalent Strip Widths for Slab-Type Bridges.....	4-48
4.6.2.4—Truss and Arch Bridges.....	4-49
4.6.2.5—Effective Length Factor, K	4-49
4.6.2.6—Effective Flange Width	4-54
4.6.2.6.1—General.....	4-54
4.6.2.6.2—Segmental Concrete Box Beams and Single-Cell, Cast-in-Place Box Beams	4-55
4.6.2.6.3—Cast-in-Place Multicell Superstructures.....	4-59
4.6.2.6.4—Orthotropic Steel Decks.....	4-59
4.6.2.6.5—Transverse Floorbeams and Integral Bent Caps.....	4-61
4.6.2.7—Lateral Wind Load Distribution in Multibeam Bridges	4-62
4.6.2.7.1—I-Sections	4-62
4.6.2.7.2—Box Sections	4-63
4.6.2.7.3—Construction.....	4-63
4.6.2.8—Seismic Lateral Load Distribution	4-63
4.6.2.8.1—Applicability	4-63
4.6.2.8.2—Design Criteria.....	4-64
4.6.2.8.3—Load Distribution.....	4-64
4.6.2.9—Analysis of Segmental Concrete Bridges.....	4-65
4.6.2.9.1—General.....	4-65
4.6.2.9.2—Strut-and-Tie Models	4-65
4.6.2.9.3—Effective Flange Width.....	4-65
4.6.2.9.4—Transverse Analysis.....	4-66
4.6.2.9.5—Longitudinal Analysis.....	4-66
4.6.2.9.5a—General.....	4-66
4.6.2.9.5b—Erection Analysis.....	4-66

4.6.2.9.5c—Analysis of the Final Structural System.....	4-66
4.6.2.10—Equivalent Strip Widths for Box Culverts.....	4-67
4.6.2.10.1—General.....	4-67
4.6.2.10.2—Case 1: Traffic Travels Parallel to Span.....	4-67
4.6.2.10.3—Case 2: Traffic Travels Perpendicular to Span.....	4-67
4.6.2.10.4—Precast Box Culverts.....	4-68
4.6.3—Refined Methods of Analysis.....	4-68
4.6.3.1—General.....	4-68
4.6.3.2—Decks.....	4-69
4.6.3.2.1—General.....	4-69
4.6.3.2.2—Isotropic Plate Model.....	4-69
4.6.3.2.3—Orthotropic Plate Model.....	4-70
4.6.3.2.4—Refined Orthotropic Deck Model.....	4-70
4.6.3.3—Beam-Slab Bridges.....	4-70
4.6.3.3.1—General.....	4-70
4.6.3.3.2—Curved Steel Bridges.....	4-71
4.6.3.4—Cellular and Box Bridges.....	4-72
4.6.3.5—Truss Bridges.....	4-72
4.6.3.6—Arch Bridges.....	4-73
4.6.3.7—Cable-Stayed Bridges.....	4-73
4.6.3.8—Suspension Bridges.....	4-74
4.6.4—Redistribution of Negative Moments in Continuous Beam Bridges.....	4-74
4.6.4.1—General.....	4-74
4.6.4.2—Refined Method.....	4-75
4.6.4.3—Approximate Procedure.....	4-75
4.6.5—Stability.....	4-75
4.6.6—Analysis for Temperature Gradient.....	4-75
4.7—DYNAMIC ANALYSIS.....	4-77
4.7.1—Basic Requirements of Structural Dynamics.....	4-77
4.7.1.1—General.....	4-77
4.7.1.2—Distribution of Masses.....	4-77
4.7.1.3—Stiffness.....	4-78
4.7.1.4—Damping.....	4-78
4.7.1.5—Natural Frequencies.....	4-78
4.7.2—Elastic Dynamic Responses.....	4-79
4.7.2.1—Vehicle-Induced Vibration.....	4-79
4.7.2.2—Wind-Induced Vibration.....	4-79
4.7.2.2.1—Wind Velocities.....	4-79
4.7.2.2.2—Dynamic Effects.....	4-79
4.7.2.2.3—Design Considerations.....	4-79
4.7.3—Inelastic Dynamic Responses.....	4-80
4.7.3.1—General.....	4-80
4.7.3.2—Plastic Hinges and Yield Lines.....	4-80
4.7.4—Analysis for Earthquake Loads.....	4-80
4.7.4.1—General.....	4-80

4.7.4.2—Single-Span Bridges.....	4-80
4.7.4.3—Multispan Bridges.....	4-81
4.7.4.3.1—Selection of Method.....	4-81
4.7.4.3.2—Single-Mode Methods of Analysis.....	4-82
4.7.4.3.2a—General.....	4-82
4.7.4.3.2b—Single-Mode Spectral Method.....	4-82
4.7.4.3.2c—Uniform Load Method.....	4-83
4.7.4.3.3—Multimode Spectral Method.....	4-85
4.7.4.3.4—Time-History Method.....	4-85
4.7.4.3.4a—General.....	4-85
4.7.4.3.4b—Acceleration Time Histories.....	4-85
4.7.4.4—Minimum Support Length Requirements.....	4-88
4.7.4.5 P - Δ Requirements.....	4-89
4.7.5—Analysis for Collision Loads.....	4-90
4.7.6—Analysis of Blast Effects.....	4-90
4.8—ANALYSIS BY PHYSICAL MODELS.....	4-90
4.8.1—Scale Model Testing.....	4-90
4.8.2—Bridge Testing.....	4-90
4.9—REFERENCES.....	4-91
APPENDIX A4—DECK SLAB DESIGN TABLE.....	4-97

STRUCTURAL ANALYSIS AND EVALUATION

4.1—SCOPE

This section describes methods of analysis suitable for the design and evaluation of bridges and is limited to the modeling of structures and the determination of force effects.

Other methods of analysis that are based on documented material characteristics and that satisfy equilibrium and compatibility may also be used.

In general, bridge structures are to be analyzed elastically. However, this section permits the inelastic analysis or redistribution of force effects in some continuous beam superstructures. It specifies inelastic analysis for compressive members behaving inelastically and as an alternative for extreme event limit states.

C4.1

This section identifies and promotes the application of methods of structural analysis that are suitable for bridges. The selected method of analysis may vary from the approximate to the very sophisticated, depending on the size, complexity, and priority of the structure. The primary objective in the use of more sophisticated methods of analysis is to obtain a better understanding of structural behavior. Such improved understanding may often, but not always, lead to the potential for saving material.

The outlined methods of analysis, which are suitable for the determination of deformations and force effects in bridge structures, have been successfully demonstrated, and most have been used for years. Although many methods will require a computer for practical implementation, simpler methods that are amenable to hand calculation and/or to the use of existing computer programs based on line-structure analysis have also been provided. Comparison with hand calculations should always be encouraged and basic equilibrium checks should be standard practice.

With rapidly improving computing technology, the more refined and complex methods of analysis are expected to become commonplace. Hence, this section addresses the assumptions and limitations of such methods. It is important that the user understand the method employed and its associated limitations.

In general, the suggested methods of analysis are based on linear material models. This does not mean that cross-sectional resistance is limited to the linear range. This presents an obvious inconsistency in that the analysis is based on material linearity and the resistance model may be based on inelastic behavior for the strength limit states. This same inconsistency existed, however, in the load factor design method of previous editions of the AASHTO Standard Specifications, and is present in design codes of other nations using a factored design approach.

The loads and load factors, defined in Section 3, and the resistance factors specified throughout these Specifications were developed using probabilistic principles combined with analyses based on linear material models. Hence, analysis methods based on material nonlinearities to obtain force effects that are more realistic at the strength limit states and subsequent economics that may be derived are permitted only where explicitly outlined herein.

Some nonlinear behavioral effects are addressed in both the analysis and resistance sections. For example, long column behavior may be modeled via geometric nonlinear methods and may also be modeled using approximate formulae in Sections 5, 6, 7, and 8. Either method may be used, but the more refined formulations are recommended.

4.2—DEFINITIONS

Accepted Method of Analysis—A method of analysis that requires no further verification and that has become a regular part of structural engineering practice.

Arc Span—Distance between centers of adjacent bearings, or other points of support, measured horizontally along the centerline of a horizontally curved member.

Aspect Ratio—Ratio of the length to the width of a rectangle.

Boundary Conditions—Structural restraint characteristics regarding the support for and/or the continuity between structural models.

Bounding—Taking two or more extreme values of parameters to envelop the response with a view to obtaining a conservative design.

Central Angle—The angle included between two points along the centerline of a curved bridge measured from the center of the curve as shown in Figure 4.6.1.2.3-1.

Classical Deformation Method—A method of analysis in which the structure is subdivided into components whose stiffness can be independently calculated. Equilibrium and compatibility among the components is restored by determining the deformations at the interfaces.

Classical Force Method—A method of analysis in which the structure is subdivided into statically determinate components. Compatibility among the components is restored by determining the interface forces.

Closed-Box Section—A cross-section composed of two vertical or inclined webs which has at least one completely enclosed cell. A closed-section member is effective in resisting applied torsion by developing shear flow in the webs and flanges.

Closed-Form Solution—One or more equations, including those based on convergent series, that permit calculation of force effects by the direct introduction of loads and structural parameters.

Compatibility—The geometrical equality of movement at the interface of joined components.

Component—A structural unit requiring separate design consideration; synonymous with member.

Condensation—Relating the variables to be eliminated from the analysis to those being kept to reduce the number of equations to be solved.

Core Width—The width of the superstructure of monolithic construction minus the deck overhangs.

Cross-Section Distortion—Change in shape of the cross-section profile due to torsional loading.

Curved Girder—An I-, closed-box, or tub girder that is curved in a horizontal plane.

Damper—A device that transfers and reduces forces between superstructure elements and/or superstructure and substructure elements, while permitting thermal movements. The device provides damping by dissipating energy under seismic, braking, or other dynamic loads.

Deck—A component, with or without wearing surface, directly supporting wheel loads.

Deck System—A superstructure in which the deck is integral with its supporting components or in which the effects or deformation of supporting components on the behavior of the deck is significant.

Deformation—A change in structural geometry due to force effects, including axial displacement, shear displacement, and rotations.

Degree-of-Freedom—One of a number of translations or rotations required to define the movement of a node. The displaced shape of components and/or the entire structure may be defined by a number of degrees-of-freedom.

Design—Proportioning and detailing the components and connections of a bridge to satisfy the requirements of these Specifications.

Dynamic Degree-of-Freedom—A degree-of-freedom with which mass or mass effects have been associated.

Elastic—A structural material behavior in which the ratio of stress to strain is constant, the material returns to its original unloaded state upon load removal.

Element—A part of a component or member consisting of one material.

End Zone—Region of structures where normal beam theory does not apply due to structural discontinuity and/or distribution of concentrated loads.

Equilibrium—A state where the sum of forces and moments about any point in space is 0.0.

Equivalent Beam—A single straight or curved beam resisting both flexural and torsional effects.

Equivalent Strip—An artificial linear element, isolated from a deck for the purpose of analysis, in which extreme force effects calculated for a line of wheel loads, transverse or longitudinal, will approximate those actually taking place in the deck.

Finite Difference Method—A method of analysis in which the governing differential equation is satisfied at discrete points on the structure.

Finite Element Method—A method of analysis in which a structure is discretized into elements connected at nodes, the shape of the element displacement field is assumed, partial or complete compatibility is maintained among the element interfaces, and nodal displacements are determined by using energy variational principles or equilibrium methods.

Finite Strip Method—A method of analysis in which the structure is discretized into parallel strips. The shape of the strip displacement field is assumed and partial compatibility is maintained among the element interfaces. Model displacement parameters are determined by using energy variational principles or equilibrium methods.

First-Order Analysis—Analysis in which equilibrium conditions are formulated on the undeformed structure; that is, the effect of deflections is not considered in writing equations of equilibrium.

Flange Lateral Bending—Bending of a flange about an axis perpendicular to the flange plane due to lateral loads applied to the flange and/or nonuniform torsion in the member.

Flange Lateral Bending Stress—The normal stress caused by flange lateral bending.

Folded Plate Method—A method of analysis in which the structure is subdivided into plate components, and both equilibrium and compatibility requirements are satisfied at the component interfaces.

Footprint—The specified contact area between wheel and roadway surface.

Force Effect—A deformation, stress, or stress resultant, i.e., axial force, shear force, flexural, or torsional moment, caused by applied loads, imposed deformations, or volumetric changes.

Foundation—A supporting element that derives its resistance by transferring its load to the soil or rock supporting the bridge.

Frame Action—Transverse continuity between the deck and the webs of cellular cross-section or between the deck and primary components in large bridges.

Frame Action for Wind—Transverse flexure of the beam web and that of framed stiffeners, if present, by which lateral wind load is partially or completely transmitted to the deck.

Girder Radius—The radius of the circumferential centerline of a segment of a curved girder.

Global Analysis—Analysis of a structure as a whole.

Governing Position—The location and orientation of transient load to cause extreme force effects.

Grillage Analogy Method—A method of analysis in which all or part of the superstructure is discretized into orthotropic components that represent the characteristics of the structure.

Inelastic—Any structural behavior in which the ratio of stress and strain is not constant, and part of the deformation remains after load removal.

Lane Live Load—The combination of tandem axle and uniformly distributed loads or the combination of the design truck and design uniformly distributed load.

Large Deflection Theory—Any method of analysis in which the effects of deformation upon force effects is taken into account.

Lever Rule—The statical summation of moments about one point to calculate the reaction at a second point.

Linear Response—Structural behavior in which deflections are directly proportional to loads.

Local Analysis—An in-depth study of strains and stresses in or among components using force effects obtained from a more global analysis.

Local Structural Stress—The stress at a welded detail including all stress raising effects of a structural detail but excluding all stress concentrations due to the local weld profile itself.

Member—Same as *Component*.

Method of Analysis—A mathematical process by which structural deformations, forces, and stresses are determined.

Model—A mathematical or physical idealization of a structure or component used for analysis.

Monolithic Construction—Single cell steel and/or concrete box bridges, solid or cellular cast-in-place concrete deck systems, and decks consisting of precast, solid, or cellular longitudinal elements effectively tied together by transverse post-tensioning.

M/R Method—An approximate method for the analysis of curved box girders in which the curved girder is treated as an equivalent straight girder to calculate flexural effects and as a corresponding straight conjugate beam to calculate the concomitant St. Venant torsional moments due to curvature.

Negative Moment—Moment producing tension at the top of a flexural element.

Node—A point where finite elements or grid components meet; in conjunction with finite differences, a point where the governing differential equations are satisfied.

Nonlinear Response—Structural behavior in which the deflections are not directly proportional to the loads due to stresses in the inelastic range, or deflections causing significant changes in force effects, or by a combination thereof.

Nonuniform Torsion—An internal resisting torsion in thin-walled sections, also known as warping torsion, producing shear stress and normal stresses, and under which cross-sections do not remain plane. Members resist the externally applied torsion by warping torsion and St. Venant torsion. Each of these components of internal resisting torsion varies along the member length, although the externally applied concentrated torque may be uniform along the member between two adjacent points of torsional restraint. Warping torsion is dominant over St. Venant torsion in

members having open cross-sections, whereas St. Venant torsion is dominant over warping torsion in members having closed cross-sections.

Open Section—A cross-section which has no enclosed cell. An open-section member resists torsion primarily by nonuniform torsion, which causes normal stresses at the flange tips.

Orthotropic—Perpendicular to each other, having physical properties that differ in two or more orthogonal directions.

Panel Point—The point where centerlines of members meet, usually in trusses, arches, cable-stayed, and suspension bridges.

Pin Connection—A connection among members by a notionally frictionless pin at a point.

Pinned End—A boundary condition permitting free rotation but not translation in the plane of action.

Point of Contraflexure—The point where the sense of the flexural moment changes; synonymous with point of inflection.

Positive Moment—Moment producing tension at the bottom of a flexural element.

Primary Member—A member designed to carry the loads applied to the structure as determined from an analysis.

Rating Vehicle—A sequence of axles used as a common basis for expressing bridge resistance.

Refined Methods of Analysis—Methods of structural analysis that consider the entire superstructure as an integral unit and provide the required deflections and actions.

Restrainers—A system of high-strength cables or rods that transfers forces between superstructure elements and/or superstructure and substructure elements under seismic or other dynamic loads after an initial slack is taken up, while permitting thermal movements.

Rigidity—Force effect caused by a corresponding unit deformation per unit length of a component.

Secondary Member—A member in which stress is not normally evaluated in the analysis.

Second-Order Analysis—Analysis in which equilibrium conditions are formulated on the deformed structure; that is, in which the deflected position of the structure is used in writing the equations of equilibrium.

Series or Harmonic Method—A method of analysis in which the load model is subdivided into suitable parts, allowing each part to correspond to one term of a convergent infinite series by which structural deformations are described.

Shear Flow—Shear force per unit width acting parallel to the edge of a plate element.

Shear Lag—Nonlinear distribution of normal stress across a component due to shear distortions.

Shock Transmission Unit (STU)—A device that provides a temporary rigid link between superstructure elements and/or superstructure and substructure elements under seismic, braking, or other dynamic loads, while permitting thermal movements.

Skew Angle—Angle between the centerline of a support and a line normal to the roadway centerline.

Small Deflection Theory—A basis for methods of analysis where the effects of deformation upon force effects in the structure is neglected.

Spacing of Beams—The center-to-center distance between lines of support.

Spine Beam Model—An analytical model of a bridge in which the superstructure is represented by a single beam element or a series of straight, chorded beam elements located along the centerline of the bridge.

Spread Beams—Beams not in physical contact, carrying a cast-in-place concrete deck.

Stiffness—Force effect resulting from a unit deformation.

Strain—Elongation per unit length.

Stress Range—The algebraic difference between extreme stresses.

St. Venant Torsion—That portion of the internal resisting torsion in a member producing only pure shear stresses on a cross-section; also referred to as pure torsion or uniform torsion.

Submodel—A constituent part of the global structural model.

Superimposed Deformation—Effect of settlement, creep, and change in temperature and/or moisture content.

Superposition—The situation where the force effect due to one loading can be added to the force effect due to another loading. Use of superposition is only valid when the stress-strain relationship is linearly elastic and the small deflection theory is used.

Tandem—Two closely spaced and mechanically interconnected axles of equal weight.

Through-Thickness Stress—Bending stress in a web or box flange induced by distortion of the cross-section.

Torsional Shear Stress—Shear stress induced by St. Venant torsion.

Tub Section—An open-topped section which is composed of a bottom flange, two inclined or vertical webs, and top flanges.

Uncracked Section—A section in which the concrete is assumed to be fully effective in tension and compression.

V-Load Method—An approximate method for the analysis of curved I-girder bridges in which the curved girders are represented by equivalent straight girders and the effects of curvature are represented by vertical and lateral forces applied at cross-frame locations. Lateral flange bending at brace points due to curvature is estimated.

Warping Stress—Normal stress induced in the cross-section by warping torsion and/or by distortion of the cross-section.

Wheel Load—One-half of a specified design axle load.

Yield Line—A plastic hinge line.

Yield Line Method—A method of analysis in which a number of possible yield line patterns are examined in order to determine load-carrying capacity.

4.3—NOTATION

A	=	area of a stringer, beam, or component (in. ²) (4.6.2.2.1)
A_b	=	cross-sectional area of barrier (in. ²) (C4.6.2.6.1)
A_c	=	cross-section area—transformed for steel beams (in. ²) (C4.6.6)
A_o	=	area enclosed by centerlines of elements (in. ²) (C4.6.2.2.1)
A_s	=	total area of stiffeners (in. ²) (4.6.2.6.4)
a	=	length of transition region for effective flange width of a concrete box beam (in.); longitudinal stiffener, spacing, or rib width in an orthotropic steel deck (in.) (4.6.2.6.2) (4.6.2.6.4)
B	=	spacing of transverse beams (in.) (4.6.2.6.4)
b	=	tire length (in.); width of a beam (in.); width of plate element (in.); flange width each side of the web (in.) (4.6.2.1.8) (4.6.2.2.1) (C4.6.2.2.1) (4.6.2.6.2)

b_e	=	effective flange width corresponding to the particular position of the section of interest in the span as specified in Figure 4.6.2.6.2-1 (in.) (4.6.2.6.2)
b_m	=	effective flange width for interior portions of a span as determined from Figure 4.6.2.6.2-2; a special case of b_e (in.) (4.6.2.6.2)
b_n	=	effective flange width for normal forces acting at anchorage zones (in.) (4.6.2.6.2)
b_o	=	width of web projected to midplane of deck (in.) (4.6.2.6.2)
b_s	=	effective flange width at interior support or for cantilever arm as determined from Figure 4.6.2.6.2-2; a special case of b_e (in.) (4.6.2.6.2)
C	=	continuity factor; stiffness parameter (4.6.2.1.8) (4.6.2.2.1)
C_m	=	moment gradient coefficient (4.5.3.2.2b)
C_{sm}	=	the dimensionless elastic seismic response coefficient (C4.7.4.3.2b)
c_1	=	parameter for skewed supports (4.6.2.2.2e)
D	=	web depth of a horizontally curved girder (ft); D_x/D_y ; width of distribution per lane (ft) (C4.6.1.2.4b) (4.6.2.1.8) (4.6.2.2.1)
D_x	=	flexural rigidity in direction of main bars (kip- ft ² /ft) (4.6.2.1.8)
D_y	=	flexural rigidity perpendicular to the main bars (kip-ft ² /ft) (4.6.2.1.8)
d	=	depth of a beam or stringer (in.); depth of member (ft) (4.6.2.2.1) (C4.6.2.7.1)
d_e	=	horizontal distance from the centerline of the exterior web of exterior beam at the deck level to the interior edge of curb or traffic barrier (ft) (4.6.2.2.1)
d_o	=	depth of superstructure (in.) (4.6.2.6.2)
E	=	modulus of elasticity (ksi); equivalent width (in.); equivalent distribution width perpendicular to span (in.) (4.5.3.2.2b) (4.6.2.3) (4.6.2.10.2)
E_B	=	modulus of elasticity of beam material (ksi) (4.6.2.2.1)
E_c	=	modulus of elasticity of column (ksi) (C4.6.2.5)
E_D	=	modulus of elasticity of deck material (ksi) (4.6.2.2.1)
E_g	=	modulus of elasticity of beam or other restraining member (ksi) (C4.6.2.5)
E_{MOD}	=	cable modulus of elasticity, modified for nonlinear effects (ksi) (4.6.3.7)
E_{span}	=	equivalent distribution length parallel to span (in.) (4.6.2.10.2)
e	=	correction factor for distribution; eccentricity of a lane from the center of gravity of the pattern of girders (ft); rib spacing in orthotropic steel deck (in.) (4.6.2.2.1) (C4.6.2.2.2d) (4.6.2.6.4)
e_g	=	distance between the centers of gravity of the beam and deck (in.) (4.6.2.2.1)
f_c	=	factored stress, corrected to account for second-order effects (ksi) (4.5.3.2.2b)
f_{2b}	=	stress corresponding to M_{2b} (ksi) (4.5.3.2.2b)
f_{2s}	=	stress corresponding to M_{2s} (ksi) (4.5.3.2.2b)
G	=	final force effect applied to a girder (kip or kip-ft); shear modulus (ksi) (4.6.2.2.4) (C4.6.3.3)
G_a	=	ratio of stiffness of column to stiffness of members resisting column bending at “a” end (C4.6.2.5)
G_b	=	ratio of stiffness of column to stiffness of members resisting column bending at “b” end (C4.6.2.5)
G_D	=	force effect due to design loads (kip or kip-ft) (4.6.2.2.4)
G_P	=	force effect due to overload truck (kip or kip-ft) (4.6.2.2.4)
g	=	distribution factor; acceleration of gravity (ft/sec. ²) (4.6.2.2.1) (C4.7.4.3.2)
g_m	=	multiple lane live load distribution factor (4.6.2.2.4)
g_1	=	single lane live load distribution factor (4.6.2.2.4)
H	=	depth of fill from top of culvert to top of pavement (in.); average height of substructure supporting the seat under consideration (ft) (4.6.2.10.2) (4.7.4.4)
H, H_1, H_2	=	horizontal component of cable force (kip) (4.6.3.7)
h	=	depth of deck (in.) (4.6.2.1.3)
I	=	moment of inertia (in. ⁴) (4.5.3.2.2b)
I_c	=	moment of inertia of column (in. ⁴); inertia of cross-section—transformed for steel beams (in. ⁴) (C4.6.2.5) (C4.6.6)
I_g	=	moment of inertia of member acting to restrain column bending (in. ⁴) (C4.6.2.5)
IM	=	dynamic load allowance (C4.7.2.1)
I_p	=	polar moment of inertia (in. ⁴) (4.6.2.2.1)
I_s	=	inertia of equivalent strip (in. ⁴) (4.6.2.1.5)
J	=	St. Venant torsional inertia (in. ⁴) (4.6.2.2.1)
K	=	effective length factor for columns and arch ribs; constant for different types of construction; effective length factor for columns in the plane of bending (4.5.3.2.2b) (4.6.2.2.1) (4.6.2.5)
K_g	=	longitudinal stiffness parameter (in. ⁴) (4.6.2.2.1)

k	=	factor used in calculation of distribution factor for multibeam bridges (4.6.2.2.1)
k_s	=	strip stiffness factor (kip/in.) (4.6.2.1.5)
L	=	span length of deck (ft); span length (ft); span length of beam (ft); length of bridge deck (ft) (4.6.2.1.3) (4.6.2.1.8) (4.6.2.2.1) (4.7.4.4)
L_{as}	=	effective arc span of a horizontally curved girder (ft) (4.6.1.2.4b)
L_b	=	spacing of brace points (ft) (C4.6.2.7.1)
L_c	=	unbraced length of column (in.) (C4.6.2.5)
L_g	=	unsupported length of beam or other restraining member (in.) (C4.6.2.5)
$LLDF$	=	factor for distribution of live load with depth of fill, 1.15 or 1.00, as specified in Article 3.6.1.2.6 (4.6.2.10.2)
L_T	=	length of tire contact area parallel to span, as specified in Article 3.6.1.2.5 (in.) (4.6.2.10.2)
L_1	=	modified span length taken to be equal to the lesser of the actual span or 60.0 (ft); distance between points of inflection of the transverse beam (in.) (4.6.2.3) (4.6.2.6.4)
L_2	=	distances between points of inflection of the transverse beam (in.) (4.6.2.6.4)
l_i	=	a notional span length (ft) (4.6.2.6.2)
ℓ	=	unbraced length of a horizontally curved girder (ft) (C4.6.1.2.4b)
ℓ_u	=	unsupported length of a compression member (in.); one-half of the length of the arch rib (ft) (4.5.3.2.2b) (4.5.3.2.2c)
M	=	major-axis bending moment in a horizontally curved girder (kip-ft); moment due to live load in filled or partially filled grid deck (kip-in./ft) (C4.6.1.2.4b) (4.6.2.1.8)
M_c	=	factored moment, corrected to account for second-order effects (kip-ft); moment required to restrain uplift caused by thermal effects (kip-in.) (4.5.3.2.2b) (C4.6.6)
M_{lat}	=	flange lateral bending moment due to curvature (kip-ft) (C4.6.1.2.4b)
MM	=	multimode elastic method (4.7.4.3.1)
M_n	=	nominal flexural strength (4.7.4.5)
M_w	=	maximum lateral moment in the flange due to the factored wind loading (kip-ft) (C4.6.2.7.1)
M_{1b}	=	smaller end moment on compression member due to gravity loads that result in no appreciable sidesway; positive if member is bent in single curvature, negative if bent in double curvature (kip-in.) (4.5.3.2.2b)
M_{2b}	=	moment on compression member due to factored gravity loads that result in no appreciable sidesway calculated by conventional first-order elastic frame analysis; always positive (kip-ft) (4.5.3.2.2b)
M_{2s}	=	moment on compression member due to factored lateral or gravity loads that result in sidesway, Δ , greater than $\ell_u/1500$, calculated by conventional first-order elastic frame analysis; always positive (kip-ft) (4.5.3.2.2b)
N	=	constant for determining the lateral flange bending moment in I-girder flanges due to curvature, taken as 10 or 12 in past practice; axial force (kip); minimum support length (in.) (C4.6.1.2.4b) (C4.6.6) (4.7.4.4)
N_b	=	number of beams, stringers, or girders (4.6.2.2.1)
N_c	=	number of cells in a concrete box girder (4.6.2.2.1)
N_L	=	number of design lanes (4.6.2.2.1)
n	=	modular ratio between beam and deck (4.6.2.2.1)
P	=	axle load (kip) (4.6.2.1.3)
P_D	=	design horizontal wind pressure (ksf) (C4.6.2.7.1)
P_e	=	Euler buckling load (kip) (4.5.3.2.2b)
P_u	=	factored axial load (kip) (4.5.3.2.2b) (4.7.4.5)
P_w	=	lateral wind force applied to the brace point (kips) (C4.6.2.7.1)
p	=	tire pressure (ksi) (4.6.2.1.8)
p_e	=	equivalent uniform static seismic loading per unit length of bridge that is applied to represent the primary mode of vibration (kip/ft) (C4.7.4.3.2c)
$p_e(x)$	=	the intensity of the equivalent static seismic loading that is applied to represent the primary mode of vibration (kip/ft) (C4.7.4.3.2b)
p_o	=	a uniform load arbitrarily set equal to 1.0 (kip/ft) (C4.7.4.3.2b)
R	=	girder radius (ft); load distribution to exterior beam in terms of lanes; radius of curvature; R -factor for calculation of seismic design forces due to inelastic action (C4.6.1.2.4b) (C4.6.2.2.2d) (C4.6.6) (4.7.4.5)
R_d	=	R_d -factor for calculation of seismic displacements due to inelastic action (4.7.4.5)
r	=	reduction factor for longitudinal force effect in skewed bridges (4.6.2.3)
S	=	spacing of supporting components (ft); spacing of beams or webs (ft); clear span (ft); skew of support measured from line normal to span (degrees) (4.6.2.1.3) (4.6.2.2.1) (4.6.2.10.2) (4.7.4.4)
S_b	=	spacing of grid bars (in.) (4.6.2.1.3)
SM	=	single-mode elastic method (4.7.4.3.1)
s	=	length of a side element (in.) (C4.6.2.2.1)
T	=	period of fundamental mode of vibration (sec.) (4.7.4.5)

T_G	=	temperature gradient ($\Delta^\circ\text{F}$) (C4.6.6)
TH	=	time history method (4.7.4.3.1)
T_m	=	period of m th mode of vibration (sec.) (C4.7.4.3.2b)
T_S	=	reference period used to define shape of seismic response spectrum (sec.) (4.7.4.5)
T_u	=	uniform specified temperature ($^\circ\text{F}$) (C4.6.6)
T_{UG}	=	temperature averaged across the cross-section ($^\circ\text{F}$) (C4.6.6)
t	=	thickness of plate-like element (in.); thickness of flange plate in orthotropic steel deck (in.) (C4.6.2.2.1) (4.6.2.6.4)
t_g	=	depth of steel grid or corrugated steel plank including integral concrete overlay or structural concrete component, less a provision for grinding, grooving, or wear (in.) (4.6.2.2.1)
t_o	=	depth of structural overlay (in.) (4.6.2.2.1)
t_s	=	depth of concrete slab (in.) (4.6.2.2.1)
V_{LD}	=	maximum vertical shear at $3d$ or $L/4$ due to wheel loads distributed laterally as specified herein (kips) (4.6.2.2.2a)
V_{LL}	=	distributed live load vertical shear (kips) (4.6.2.2.2a)
V_{LU}	=	maximum vertical shear at $3d$ or $L/4$ due to undistributed wheel loads (kips) (4.6.2.2.2a)
$v_s(x)$	=	deformation corresponding to p_o (ft) (C4.7.4.3.2b)
$v_{s,MAX}$	=	maximum value of $v_s(x)$ (ft) (C4.7.4.3.2c)
W	=	edge-to-edge width of bridge (ft); factored wind force per unit length (kip/ft); total weight of cable (kip); total weight of bridge (kip) (4.6.2.2.1) (C4.6.2.7.1) (4.6.3.7) (C4.7.4.3.2c)
W_e	=	half the web spacing, plus the total overhang (ft) (4.6.2.2.1)
W_1	=	modified edge-to-edge width of bridge taken to be equal to the lesser of the actual width or 60.0 for multilane loading, or 30.0 for single-lane loading (ft) (4.6.2.3)
w	=	width of clear roadway (ft); width of element in cross-section (in.) (4.6.2.2.2b) (C4.6.6)
$w(x)$	=	nominal, unfactored dead load of the bridge superstructure and tributary substructure (kip/ft) (C4.7.4.3.2) (4.7.4.3.2c)
w_p	=	plank width (in.) (4.6.2.1.3)
X	=	distance from load to point of support (ft) (4.6.2.1.3)
X_{ext}	=	horizontal distance from the center of gravity of the pattern of girders to the exterior girder (ft) (C4.6.2.2.2d)
x	=	horizontal distance from the center of gravity of the pattern of girders to each girder (ft) (C4.6.2.2.2d)
Z	=	a factor taken as 1.20 where the lever rule was not utilized, and 1.0 where the lever rule was used for a single lane live load distribution factor (4.6.2.2.4)
z	=	vertical distance from center of gravity of cross-section (in.) (C4.6.6)
α	=	angle between cable and horizontal (degrees); coefficient of thermal expansion (in./in./ $^\circ\text{F}$); generalized flexibility (4.6.3.7) (C4.6.6) (C4.7.4.3.2b)
β	=	generalized participation (C4.7.4.3.2b)
γ	=	load factor; generalized mass (C4.6.2.7.1) (C4.7.4.3.2b)
Δ	=	displacement of point of contraflexure in column or pier relative to point of fixity for the foundation (in.) (4.7.4.5)
Δ_e	=	displacement calculated from elastic seismic analysis (in.) (4.7.4.5)
Δw	=	overhang width extension (in.) (C4.6.2.6.1)
δ_b	=	moment or stress magnifier for braced mode deflection (4.5.3.2.2b)
δ_s	=	moment or stress magnifier for unbraced mode deflection (4.5.3.2.2b)
ϵ_u	=	uniform axial strain due to axial thermal expansion (in./in.) (C4.6.6)
η_i	=	load modifier relating to ductility, redundancy, and operational importance as specified in Article 1.3.2.1 (C4.2.6.7.1)
θ	=	skew angle (degrees) (4.6.2.2.1)
μ	=	Poisson's ratio (4.6.2.2.1)
σ_E	=	internal stress due to thermal effects (ksi) (C4.6.6)
ϕ	=	rotation per unit length; flexural resistance factor (C4.6.6) (4.7.4.5)
ϕ_K	=	stiffness reduction factor = 0.75 for concrete members and 1.0 for steel and aluminum members (4.5.3.2.2b)

4.4—ACCEPTABLE METHODS OF STRUCTURAL ANALYSIS

C4.4

Any method of analysis that satisfies the requirements of equilibrium and compatibility and

Many computer programs are available for bridge analysis. Various methods of analysis, ranging from

utilizes stress-strain relationships for the proposed materials may be used, including, but not limited to:

- Classical force and displacement methods,
- Finite difference method,
- Finite element method,
- Folded plate method,
- Finite strip method,
- Grillage analogy method,
- Series or other harmonic methods,
- Methods based on the formation of plastic hinges, and
- Yield line method.

The Designer shall be responsible for the implementation of computer programs used to facilitate structural analysis and for the interpretation and use of results.

The name, version, and release date of software used should be indicated in the contract documents.

4.5—MATHEMATICAL MODELING

4.5.1—General

Mathematical models shall include loads, geometry, and material behavior of the structure, and, where appropriate, response characteristics of the foundation. The choice of model shall be based on the limit states investigated, the force effect being quantified, and the accuracy required.

Unless otherwise permitted, consideration of continuous composite barriers shall be limited to service and fatigue limit states and to structural evaluation.

The stiffness of structurally discontinuous railings, curbs, elevated medians, and barriers shall not be considered in structural analysis.

For the purpose of this section, an appropriate representation of the soil and/or rock that supports the bridge shall be included in the mathematical model of the foundation.

In the case of seismic design, gross soil movement and liquefaction should also be considered.

If lift-off is indicated at a bearing, the analysis shall recognize the vertical freedom of the girder at that bearing.

simple formulae to detailed finite element procedures, are implemented in such programs. Many computer programs have specific engineering assumptions embedded in their code, which may or may not be applicable to each specific case.

When using a computer program, the Designer should clearly understand the basic assumptions of the program and the methodology that is implemented.

A computer program is only a tool, and the user is responsible for the generated results. Accordingly, all output should be verified to the extent possible.

Computer programs should be verified against the results of:

- Universally accepted closed-form solutions,
- Other previously verified computer programs, or
- Physical testing.

The purpose of identifying software is to establish code compliance and to provide a means of locating bridges designed with software that may later be found deficient.

C4.5.1

Service and fatigue limit states should be analyzed as fully elastic, as should strength limit states, except in case of certain continuous girders where inelastic analysis is specifically permitted, inelastic redistribution of negative bending moment and stability investigation. The extreme event limit states may require collapse investigation based entirely on inelastic modeling.

Very flexible bridges, e.g., suspension and cable-stayed bridges, should be analyzed using nonlinear elastic methods, such as the large deflection theory.

The need for sophisticated modeling of foundations is a function of the sensitivity of the structure to foundation movements.

In some cases, the foundation model may be as simple as unyielding supports. In other cases, an estimate of settlement may be acceptable. Where the structural response is particularly sensitive to the boundary conditions, such as in a fixed-end arch or in computing natural frequencies, rigorous modeling of the foundation should be made to account for the conditions present. In lieu of rigorous modeling, the boundary conditions may be varied to extreme bounds, such as fixed or free of restraint, and envelopes of force effects considered.

Where lift-off restraints are provided in the contract documents, the construction stage at which the restraints are to be installed should be clearly indicated. The

analysis should recognize the vertical freedom of the girder consistent with the construction sequence shown in the contract documents.

4.5.2—Structural Material Behavior

4.5.2.1—Elastic Versus Inelastic Behavior

For the purpose of analysis, structural materials shall be considered to behave linearly up to an elastic limit and inelastically thereafter.

Actions at the extreme event limit state may be accommodated in both the inelastic and elastic ranges.

4.5.2.2—Elastic Behavior

Elastic material properties and characteristics shall be in accordance with the provisions of Sections 5, 6, 7, and 8. Changes in these values due to maturity of concrete and environmental effects should be included in the model, where appropriate.

The stiffness properties of concrete and composite members shall be based upon cracked and/or uncracked sections consistent with the anticipated behavior. Stiffness characteristics of beam-slab-type bridges may be based on full participation of concrete decks.

4.5.2.3—Inelastic Behavior

Sections of components that may undergo inelastic deformation shall be shown to be ductile or made ductile by confinement or other means. Where inelastic analysis is used, a preferred design failure mechanism and its attendant hinge locations shall be determined. It shall be ascertained in the analysis that shear, buckling, and bond failures in the structural components do not precede the formation of a flexural inelastic mechanism. Unintended overstrength of a component in which hinging is expected should be considered. Deterioration of geometrical integrity of the structure due to large deformations shall be taken into account.

The inelastic model shall be based either upon the results of physical tests or upon a representation of load-deformation behavior that is validated by tests. Where inelastic behavior is expected to be achieved by confinement, test specimens shall include the elements that provide such confinement. Where extreme force effects are anticipated to be repetitive, the tests shall reflect their cyclic nature.

Except where noted, stresses and deformations shall be based on a linear distribution of strains in the cross-section of prismatic components. Shear deformation of deep components shall be considered. Limits on concrete strain, as specified in Section 5, shall not be exceeded.

The inelastic behavior of compressive components shall be taken into account, wherever applicable.

C4.5.2.2

Tests indicate that in the elastic range of structural behavior, cracking of concrete seems to have little effect on the global behavior of bridge structures. This effect can, therefore, be safely neglected by modeling the concrete as uncracked for the purposes of structural analysis (King et al., 1975; Yen et al., 1995).

C4.5.2.3

Where technically possible, the preferred failure mechanism should be based on a response that has generally been observed to provide for large deformations as a means of warning of structural distress.

The selected mechanism should be used to estimate the extreme force effect that can be applied adjacent to a hinge.

Unintended overstrength of a component may result in an adverse formation of a plastic hinge at an undesirable location, forming a different mechanism.

4.5.3—Geometry

4.5.3.1—Small Deflection Theory

If the deformation of the structure does not result in a significant change in force effects due to an increase in the eccentricity of compressive or tensile forces, such secondary force effects may be ignored.

4.5.3.2—Large Deflection Theory

4.5.3.2.1—General

If the deformation of the structure results in a significant change in force effects, the effects of deformation shall be considered in the equations of equilibrium.

The effect of deformation and out-of-straightness of components shall be included in stability analyses and large deflection analyses.

For slender concrete compressive components, those time- and stress-dependent material characteristics that cause significant changes in structural geometry shall be considered in the analysis.

C4.5.3.1

Small deflection theory is usually adequate for the analysis of beam-type bridges. Bridges that resist loads primarily through a couple whose tensile and compressive forces remain in essentially fixed positions relative to each other while the bridge deflects, such as in trusses and tied arches, are generally insensitive to deformations. Columns and structures in which the flexural moments are increased or decreased by deflection tend to be sensitive to deflection considerations. Such structures include suspension bridges, very flexible cable-stayed bridges, and some arches other than tied arches and frames.

In many cases, the degree of sensitivity can be assessed and evaluated by a single-step approximate method, such as the moment magnification factor method. In the remaining cases, a complete second-order analysis may be necessary.

The past traditional boundary between small- and large-deflection theory becomes less distinct as bridges and bridge components become more flexible due to advances in material technology, the change from mandatory to optional deflection limits, and the trend toward more accurate, optimized design. The Engineer needs to consider these aspects in the choice of an analysis method.

Small-deflection elastic behavior permits the use of the principle of superposition and efficient analytical solutions. These assumptions are typically used in bridge analysis for this reason. The behavior of the members assumed in these provisions is generally consistent with this type of analysis.

Superposition does not apply for the analysis of construction processes that include changes in the stiffness of the structure.

Moments from noncomposite and composite analyses may not be added for the purpose of computing stresses. The addition of stresses and deflections due to noncomposite and composite actions computed from separate analyses is appropriate.

C4.5.3.2.1

A properly formulated large deflection analysis is one that provides all the force effects necessary for the design. Further application of moment magnification factors is neither required nor appropriate. The presence of compressive axial forces amplifies both out-of-straightness of a component and the deformation due to nontangential loads acting thereon, thereby increasing the eccentricity of the axial force with respect to the centerline of the component. The synergistic effect of this interaction is the apparent softening of the component, i.e., a loss of stiffness. This is commonly

The interaction effects of tensile and compressive axial forces in adjacent components should be considered in the analysis of frames and trusses.

Only factored loads shall be used and no superposition of force effects shall be applied in the nonlinear range. The order of load application in nonlinear analysis shall be consistent with that on the actual bridge.

4.5.3.2.2—Approximate Methods

4.5.3.2.2a—General

Where permitted in Sections 5, 6, and 7, the effects of deflection on force effects on beam-columns and arches which meet the provisions of these Specifications may be approximated by the single-step adjustment method known as moment magnification.

referred to as a second-order effect. The converse is true for tension. As axial compressive stress becomes a higher percentage of the so called Euler buckling stress, this effect becomes increasingly more significant.

The second-order effect arises from the translation of applied load creating increased eccentricity. It is considered as geometric nonlinearity and is typically addressed by iteratively solving the equilibrium equations or by using geometric stiffness terms in the elastic range (Przemieniecki, 1968). The analyst should be aware of the characteristics of the elements employed, the assumptions upon which they are based, and the numerical procedures used in the computer code. Discussions on the subject are given by White and Hajjar (1991) and Galambos (1998). Both references are related to metal structures, but the theory and applications are generally usable. Both contain numerous additional references that summarize the state-of-the-art in this area.

Because large deflection analysis is inherently nonlinear, the loads are not proportional to the displacements, and superposition cannot be used. This includes force effects due to changes in time-dependent properties, such as creep and shrinkage of concrete. Therefore, the order of load application can be important and traditional approaches, such as influence functions, are not directly applicable. The loads should be applied in the order experienced by the structure, i.e., dead load stages followed by live load stages, etc. If the structure undergoes nonlinear deformation, the loads should be applied incrementally with consideration for the changes in stiffness after each increment.

In conducting nonlinear analysis, it is prudent to perform a linear analysis for a baseline and to use the procedures employed on the problem at hand on a simple structure that can be analyzed by hand, such as a cantilever beam. This permits the analyst to observe behavior and develop insight into behavior that is not easily gained from more complex models.

C4.5.3.2.2a

The moment magnification procedure outlined herein is one of several variations of the approximate process and was selected as a compromise between accuracy and ease of use. It is believed to be conservative. An alternative procedure thought to be more accurate than the one specified herein may be found in AISC (1993). This alternative procedure will require supplementary calculations not commonly made in bridge design using modern computational methods.

In some cases, the magnitude of movement implied by the moment magnification process cannot be physically attained. For example, the actual movement

of a pier may be limited to the distance between the end of longitudinal beams and the backwall of the abutment. In cases where movement is limited, the moment magnification factors of elements so limited may be reduced accordingly.

4.5.3.2.2b—Moment Magnification—Beam
Columns

C4.5.3.2.2b

The factored moments or stresses may be increased to reflect effects of deformations as follows:

$$M_c = \delta_b M_{2b} + \delta_s M_{2s} \quad (4.5.3.2.2b-1)$$

$$f_c = \delta_b f_{2b} + \delta_s f_{2s} \quad (4.5.3.2.2b-2)$$

in which:

$$\delta_b = \frac{C_m}{1 - \frac{P_u}{\phi_K P_e}} \geq 1.0 \quad (4.5.3.2.2b-3)$$

$$\delta_s = \frac{1}{1 - \frac{\Sigma P_u}{\phi_K \Sigma P_e}} \quad (4.5.3.2.2b-4)$$

where:

M_{2b} = moment on compression member due to factored gravity loads that result in no appreciable sidesway calculated by conventional first-order elastic frame analysis; always positive (kip-ft)

M_{2s} = moment on compression member due to factored lateral or gravity loads that result in sidesway, Δ , greater than $\ell_u/1500$, calculated by conventional first-order elastic frame analysis; always positive (kip-ft)

f_{2b} = stress corresponding to M_{2b} (ksi)

f_{2s} = stress corresponding to M_{2s} (ksi)

P_u = factored axial load (kip)

ϕ_K = stiffness reduction factor; 0.75 for concrete members and 1.0 for steel and aluminum members

P_e = Euler buckling load (kip)

For steel/concrete composite columns, the Euler buckling load, P_e , shall be determined as specified in Article 6.9.5.1. For all other cases, P_e shall be taken as:

$$P_e = \frac{\pi^2 EI}{(K \ell_u)^2} \quad (4.5.3.2.2b-5)$$

where:

E = modulus of elasticity (ksi)

I = moment of inertia about axis under consideration (in.⁴)

- K = effective length factor in the plane of bending as specified in Article 4.6.2.5. For calculation of δ_b , P_e shall be based on the K -factor for braced frames; for calculation of δ_s , P_e shall be based on the K -factor for unbraced frames
- ℓ_u = unsupported length of a compression member (in.)

For concrete compression members, the provisions of Article 5.7.4.3 also apply.

For members braced against sidesway, δ_s shall be taken as 1.0 unless analysis indicates that a lower value may be used. For members not braced against sidesway, δ_b shall be determined as for a braced member and δ_s for an unbraced member.

For members braced against sidesway and without transverse loads between supports, C_m may be taken as:

$$C_m = 0.6 + 0.4 \frac{M_{1b}}{M_{2b}} \quad (4.5.3.2.2b-6)$$

The previous limit $C_m \geq 0.4$ has been shown to be unnecessary in AISC (1994), Chapter C, of commentary.

where:

- M_{1b} = smaller end moment
 M_{2b} = larger end moment

The ratio M_{1b}/M_{2b} is considered positive if the component is bent in single curvature and negative if it is bent in double curvature.

For all other cases, C_m shall be taken as 1.0.

In structures that are not braced against sidesway, the flexural members and foundation units framing into the compression member shall be designed for the sum of end moments of the compression member at the joint.

Where compression members are subject to flexure about both principal axes, the moment about each axis shall be magnified by δ , determined from the corresponding conditions of restraint about that axis.

Where a group of compression members on one level comprise a bent, or where they are connected integrally to the same superstructure, and collectively resist the sidesway of the structure, the value of δ_s shall be computed for the member group with ΣP_u and ΣP_e equal to the summations for all columns in the group.

4.5.3.2.2c—Moment Magnification—Arches

Live load and impact moments from a small deflection analysis shall be increased by the moment magnification factor, δ_b , as specified in Article 4.5.3.2.2b, with the following definitions:

- ℓ_u = one-half of the length of the arch rib (ft)
 K = effective length factor specified in Table 4.5.3.2.2c-1
 C_m = 1.0

Table 4.5.3.2c-1—K Values for Effective Length of Arch Ribs

Rise to Span Ratio	3-Hinged Arch	2-Hinged Arch	Fixed Arch
0.1–0.2	1.16	1.04	0.70
0.2–0.3	1.13	1.10	0.70
0.3–0.4	1.16	1.16	0.72

4.5.3.2.3—Refined Methods

Refined methods of analysis shall be based upon the concept of forces satisfying equilibrium in a deformed position.

4.5.4—Modeling Boundary Conditions

Boundary conditions shall represent actual characteristics of support and continuity.

Foundation conditions shall be modeled in such a manner as to represent the soil properties underlying the bridge, the soil-pile interaction, and the elastic properties of piles.

4.5.5—Equivalent Members

Nonprismatic components may be modeled by discretizing the components into a number of frame elements with stiffness properties representative of the actual structure at the location of the element.

Components or groups of components of bridges with or without variable cross-sections may be modeled as a single equivalent component provided that it represents all the stiffness properties of the components or group of components. The equivalent stiffness properties may be obtained by closed-form solutions, numerical integration, submodel analysis, and series and parallel analogies.

C4.5.3.2.3

Flexural equilibrium in a deformed position may be iteratively satisfied by solving a set of simultaneous equations, or by evaluating a closed-form solution formulated using the displaced shape.

C4.5.4

If the accurate assessment of boundary conditions cannot be made, their effects may be bounded.

C4.5.5

Standard frame elements in available analysis programs may be used. The number of elements required to model the nonprismatic variation is dependent on the type of behavior being modeled, e.g., static, dynamic, or stability analysis. Typically, eight elements per span will give sufficient accuracy for actions in a beam loaded statically with cross-sectional properties that vary smoothly. Fewer elements are required to model for deflection and frequency analyses.

Alternatively, elements may be used that are based on the assumed tapers and cross-sections. Karabalis (1983) provides a comprehensive examination of this issue. Explicit forms of stiffness coefficients are given for linearly tapered rectangular, flanged, and box sections. Aristizabal (1987) presents similar equations in a simple format that can be readily implemented into stiffness-based computer programs. Significant bibliographies are given in Karabalis (1983) and Aristizabal (1987).

4.6—STATIC ANALYSIS

4.6.1—Influence of Plan Geometry

4.6.1.1—Plan Aspect Ratio

If the span length of a superstructure with torsionally stiff closed cross-sections exceeds 2.5 times its width, the superstructure may be idealized as a single-spine beam. The following dimensional definitions shall be used to apply this criterion:

- Width—the core width of a monolithic deck or the average distance between the outside faces of exterior webs.
- Length for rectangular simply supported bridges—the distance between deck joints.
- Length for continuous and/or skewed bridges—the length of the longest side of the rectangle that can be drawn within the plan view of the width of the smallest span, as defined herein.

The length-to-width restriction specified above does not apply to cast-in-place multicell box girders concrete box girder bridges.

4.6.1.2—Structures Curved in Plan

4.6.1.2.1—General

The moments, shears, and other force effects required to proportion the superstructure components shall be based on a rational analysis of the entire superstructure. Analysis of sections with no axis of symmetry should consider the relative locations of the center of gravity and the shear center. The substructure shall also be considered in the case of integral abutments, piers, or bents.

The entire superstructure, including bearings, shall be considered as an integral structural unit. Boundary conditions shall represent the articulations provided by the bearings and/or integral connections used in the design. Analyses may be based on elastic small-deflection theory, unless more rigorous approaches are deemed necessary by the Engineer.

Analyses shall consider bearing orientation and restraint of bearings afforded by the substructure. These load effects shall be considered in designing bearings, cross-frames, diaphragms, bracing, and the deck.

Distortion of the cross-section need not be considered in the structural analysis.

Centrifugal force effects shall be considered in accordance with Article 3.6.3.

C4.6.1.1

Where transverse distortion of a superstructure is small in comparison with longitudinal deformation, the former does not significantly affect load distribution, hence, an equivalent beam idealization is appropriate. The relative transverse distortion is a function of the ratio between structural width and height, the latter, in turn, depending on the length. Hence, the limits of such idealization are determined in terms of the width-to-effective length ratio.

Simultaneous torsion, moment, shear, and reaction forces and the attendant stresses are to be superimposed as appropriate. The equivalent beam idealization does not alleviate the need to investigate warping effects in steel structures. In all equivalent beam idealizations, the eccentricity of loads should be taken with respect to the centerline of the equivalent beam. Asymmetrical sections need to consider the relative location of the shear center and center of gravity.

C4.6.1.2.1

Since equilibrium of horizontally curved I-girders is developed by the transfer of load between the girders, the analysis must recognize the integrated behavior of all structural components. Equilibrium of curved box girders may be less dependent on the interaction between girders. Bracing members are considered primary members in curved bridges since they transmit forces necessary to provide equilibrium.

The deck acts in flexure, vertical shear, and horizontal shear. Torsion increases the horizontal deck shear, particularly in curved box girders. The lateral restraint of the bearings may also cause horizontal shear in the deck.

Small-deflection theory is adequate for the analysis of most curved-girder bridges. However, curved I-girders are prone to deflect laterally when the girders are insufficiently braced during erection. This behavior may not be well recognized by small-deflection theory.

Classical methods of analysis usually are based on strength of materials assumptions that do not recognize cross-section deformation. Finite element analyses that model the actual cross-section shape of the I- or box girders can recognize cross-section distortion and its effect on structural behavior. Cross-section deformation of steel box girders may have a significant effect on torsional behavior, but this effect is limited by the provision of sufficient internal cross bracing.

4.6.1.2.2—Single-Girder Torsionally Stiff Superstructures

Except for concrete box girder bridges, a horizontally curved, torsionally stiff single-girder superstructure meeting the requirements of Article 4.6.1.1 may be analyzed for global force effects as a curved spine beam.

The location of the centerline of such a beam shall be taken at the center of gravity of the cross-section, and the eccentricity of dead loads shall be established by volumetric consideration.

4.6.1.2.3—Concrete Box Girder Bridges

Horizontally curved concrete box girders may be designed with straight segments, for central angles up to 12 degrees within one span, unless concerns about other force effects dictate otherwise.

Horizontally curved nonsegmental concrete box girder bridge superstructures may be analyzed and designed for global force effects as single-spine beams with straight segments for central angles up to 34 degrees within one span as shown in Figure 4.6.1.2.3-1, unless concerns about local force effects dictate otherwise. The location of the centerline of such a beam shall be taken at the center of gravity of the cross-section and the eccentricity of dead loads shall be established by volumetric consideration. Where the substructure is integral with the superstructure, the substructure elements shall be included in the model and allowance made for prestress friction loss due to horizontal curvature or tendon deviation.

C4.6.1.2.2

In order to apply the aspect ratio provisions of Article 4.6.1.1, as specified, the plan needs to be hypothetically straightened. Force effects should be calculated on the basis of the actual curved layout.

With symmetrical cross-sections, the center of gravity of permanent loads falls outside the center of gravity. Shear center of the cross-section and the resulting eccentricity need to be investigated.

C4.6.1.2.3

Concrete box girders generally behave as a single-girder multi-web torsionally stiff superstructure. A parameter study conducted by Song, Chai, and Hida (2003) indicated that the distribution factors from the LRFD formulae compared well with the distribution factors from grillage analyses when using straight segments on spans with central angles up to 34 degrees in one span.

Nutt, Redfield, and Valentine (2008) studied the limits of applicability for various methods of analyzing horizontally curved concrete box girder bridges. The focus of this study was on local as well as global force effects and provided the basis for revisions in 2010. They identified three approaches for the analysis of concrete box girder bridges as follows:

1. The first method allows bridges with a central angle within one span of less than 12 degrees to be analyzed as if they were straight because curvature has a minor effect on response. This is typically done with a plane frame analysis.
2. The second method involves a spine beam analysis which the superstructure is idealized as a series of straight beam chorded segments of limited central angle located along the bridge centerline. Where the substructure is integral with the superstructure, a space frame analysis is required. Whole-width design as described in Article 4.6.2.2.1 was found to yield conservative results when space frame analysis was used. It is acceptable to reduce the number of live load lanes applied to the whole-width model to those that can fit on the bridge when global response such as torsion or transverse bending is being considered.
3. Bridges with high curvatures or unusual plan geometry require a third method of analysis that utilizes sophisticated three-dimensional computer models. Unusual plan geometry includes but is not limited to bridges with variable widths or with unconventional orientation of skewed supports.

The range of applicability using approximate methods herein is expected to yield results within five percent of the most detailed type of analysis. Analysis of force effects in curved tendons is also addressed in Article 5.10.4.3.

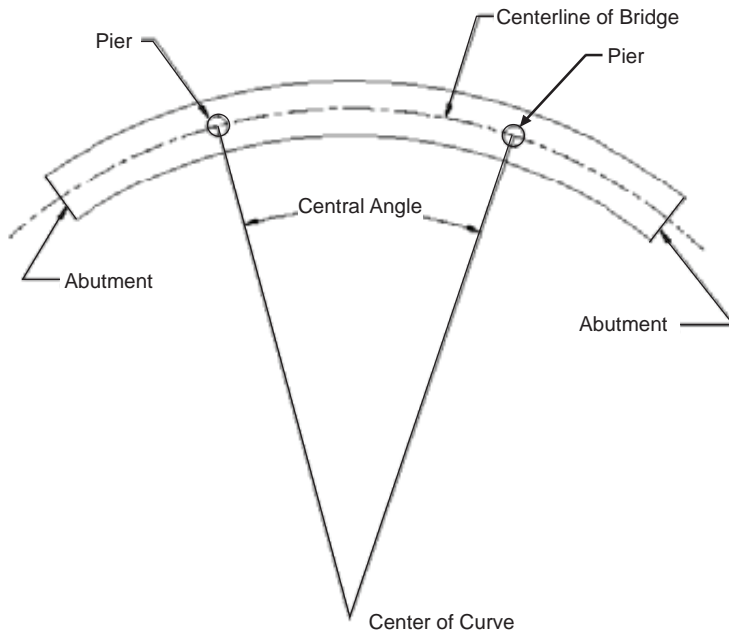

Figure 4.6.1.2.3-1—Definition of Central Angle

Horizontally curved segmental concrete box girder superstructures meeting the requirements of Article 4.6.1.1, and whose central angle within one span is between 12 degrees and 34 degrees may be analyzed as a single-spine beam comprised of straight segments provided no segment has a central angle greater than 3.5 degrees as shown in Figure 4.6.1.2.3-2. For integral substructures, an appropriate three-dimensional model of the structure shall be used. Redistribution of forces due to the time-dependant properties of concrete shall be accounted for.

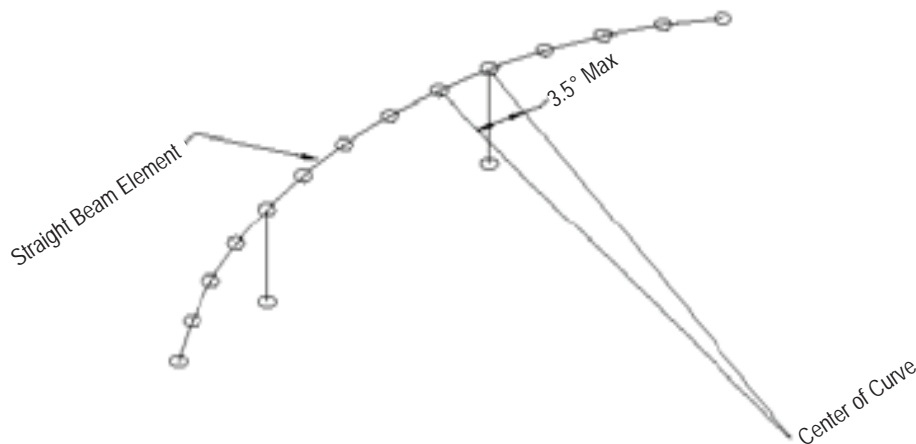

Figure 4.6.1.2.3-2—Three-Dimensional Spine Model of Curved Concrete Box Girder Bridge

For both segmental and nonsegmental box girder bridges with central angles exceeding 34 degrees within any one span or for bridges with a maximum central angle in excess of 12 degrees with unusual plan geometry, the bridge shall be analyzed using 6 degrees of freedom in a proven three-dimensional analysis method.

4.6.1.2.4—Steel Multiple-Beam Superstructures

4.6.1.2.4a—General

Horizontally curved superstructures may be analyzed as grids or continuums in which the segments of the longitudinal beams are assumed to be straight between nodes. The actual eccentricity of the segment between the nodes shall not exceed 2.5 percent of the length of the segment.

4.6.1.2.4b—I-Girders

The effect of curvature on stability shall be considered for all curved I-girders.

Where I-girder bridges meet the following four conditions, the effects of curvature may be ignored in the analysis for determining the major-axis bending moments and bending shears:

- Girders are concentric;
- Bearing lines are not skewed more than 10 degrees from radial;
- The stiffnesses of the girders are similar;
- For all spans, the arc span divided by the girder radius in feet is less than 0.06 radians where the arc span, L_{as} , shall be taken as follows:

For simple spans:

$$L_{as} = \text{arc length of the girder (ft)}$$

For end spans of continuous members:

$$L_{as} = 0.9 \text{ times the arc length of the girder (ft)}$$

For interior spans of continuous members:

$$L_{as} = 0.8 \text{ times the arc length of the girder (ft)}$$

C4.6.1.2.4a

An eccentricity of 2.5 percent of the length of the segment corresponds to a central angle subtended by a curved segment of about 12 degrees.

This Article applies only to major-axis bending moment and does not apply to lateral flange bending, or torsion, which should always be examined with respect to curvature.

Bridges with even slight curvature may develop large radial forces at the abutment bearings. Therefore, thermal analysis of all curved bridges is recommended.

C4.6.1.2.4b

The requirement for similar stiffness among the girders is intended to avoid large and irregular changes in stiffness which could alter transverse distribution of load. Under such conditions, a refined analysis would be appropriate. Noncomposite dead load preferably is to be distributed uniformly to the girders since the cross-frames provide restoring forces that prevent the girders from deflecting independently. Certain dead loads applied to the composite bridge may be distributed uniformly to the girders as provided in Article 4.6.2.2.1. However, heavier concentrated line loads such as parapets, sidewalks, barriers, or sound walls should not be distributed equally to the girders. Engineering judgment must be used in determining the distribution of these loads. Often the largest portion of the load on an overhang is assigned to the exterior girder, or to the exterior girder and the first interior girder. The exterior girder on the outside of the curve is often critical in curved girder bridges.

The effect of curvature on the torsional behavior of a girder must be considered regardless of the amount of curvature since stability and strength of curved girders is different from that of straight girders (Hall and Yoo, 1996).

In lieu of a refined analysis, Eq. C4.6.1.2.4b-1 may be appropriate for determining the lateral bending moment in I-girder flanges due to curvature (Richardson, Gordon, and Associates, 1976; United States Steel, 1984).

$$M_{lat} = \frac{M \ell^2}{NRD} \quad (C4.6.1.2.4b-1)$$

An I-girder in a bridge satisfying these criteria may be analyzed as an individual straight girder with span length equal to the arc length. Lateral flange bending effects should then be determined from an appropriate approximation and considered in the design.

Cross-frame or diaphragm members shall be designed in accordance with Articles 6.7.4 and 6.13 for forces computed by rational means.

Cross-frame spacing shall be set to limit flange lateral bending in the girders.

where:

M_{lat} = flange lateral bending moment (kip-ft)

M = major-axis bending moment (kip-ft)

ℓ = unbraced length (ft)

R = girder radius (ft)

D = web depth (ft)

N = a constant taken as 10 or 12 in past practice

Although the depth to be used in computing the flange lateral moment from Eq. C4.6.1.2.4b-1 is theoretically equal to the depth, h , between the midthickness of the top and bottom flanges, for simplicity, the web depth, D , is conservatively used in Eq. C4.6.1.2.4b-1. The Engineer may substitute the depth, h , for D in Eq. C4.6.1.2.4b-1, if desired. Eq. C4.6.1.2.4b-1 assumes the presence of a cross-frame at the point under investigation, that the cross-frame spacing is relatively uniform, and that the major-axis bending moment, M , is constant between brace points. Therefore, at points not actually located at cross-frames, flange lateral moments from Eq. C4.6.1.2.4b-1 may not be strictly correct. The constant, N , in Eq. C4.6.1.2.4b-1 has been taken as either 10 or 12 in past practice and either value is considered acceptable depending on the level of conservatism that is desired.

Other conditions that produce torsion, such as skew, should be dealt with by other analytical means which generally involve a refined analysis.

4.6.1.2.4c—Closed Box and Tub Girders

The effect of curvature on strength and stability shall be considered for all curved box girders.

Where box girder bridges meet the following three conditions, the effect of curvature may be ignored in the analysis for determination of the major-axis bending moments and bending shears:

- Girders are concentric,
- Bearings are not skewed, and
- For all spans, the arc span divided by the girder radius is less than 0.3 radians, and the girder depth is less than the width of the box at mid-depth where the arc span, L_{as} , shall be taken as defined in Article 4.6.1.2.4b.

A box girder in a bridge satisfying these criteria may be analyzed as an individual straight girder with span length equal to the arc length. Lateral flange bending effects should then be found from an appropriate approximation and considered in the design.

C4.6.1.2.4c

Although box-shaped girders have not been examined as carefully as I-girders with regard to approximate methods, bending moments in closed girders are less affected by curvature than are I-girders (Tung and Fountain, 1970). However, in a box shape, torsion is much greater than in an open shape so that

web shears are affected by torsion due to curvature, skew or loads applied away from the shear center of the box. Double bearings resist significant torque compared to a box-centered single bearing.

If the box is haunched or tapered, the shallowest girder depth should be used in conjunction with the narrowest width of the box at middepth in determining whether the effects of curvature may be ignored in calculating the major axis bending moments and bending shears.

Cross-frame or diaphragm members shall be designed in accordance with the provisions of Articles 6.7.4 and 6.13 and lateral bracing members shall be designed in accordance with Articles 6.7.5 and 6.13 for forces computed by rational means.

4.6.2—Approximate Methods of Analysis

4.6.2.1—Decks

4.6.2.1.1—General

An approximate method of analysis in which the deck is subdivided into strips perpendicular to the supporting components shall be considered acceptable for decks other than:

- fully filled and partially filled grids for which the provisions of Article 4.6.2.1.8 shall apply, and
- top slabs of segmental concrete box girders for which the provisions of 4.6.2.9.4 shall apply.

Where the strip method is used, the extreme positive moment in any deck panel between girders shall be taken to apply to all positive moment regions. Similarly, the extreme negative moment over any beam or girder shall be taken to apply to all negative moment regions.

4.6.2.1.2—Applicability

The use of design aids for decks containing prefabricated elements may be permitted in lieu of analysis if the performance of the deck is documented and supported by sufficient technical evidence. The Engineer shall be responsible for the accuracy and implementation of any design aids used.

For slab bridges and concrete slabs spanning more than 15.0 ft and which span primarily in the direction parallel to traffic, the provisions of Article 4.6.2.3 shall apply.

C4.6.2.1.1

This model is analogous to past AASHTO Specifications.

In determining the strip widths, the effects of flexure in the secondary direction and of torsion on the distribution of internal force effects are accounted for to obtain flexural force effects approximating those that would be provided by a more refined method of analysis.

Depending on the type of deck, modeling and design in the secondary direction may utilize one of the following approximations:

- Secondary strip designed in a manner like the primary strip, with all the limit states applicable;
- Resistance requirements in the secondary direction determined as a percentage of that in the primary one as specified in Article 9.7.3.2 (i.e., the traditional approach for reinforced concrete slab in the previous editions of the AASHTO Standard Specifications); or
- Minimum structural and/or geometry requirements specified for the secondary direction independent of actual force effects, as is the case for most wood decks.

The approximate strip model for decks is based on rectangular layouts. Currently about two-thirds of all bridges nationwide are skewed. While skew generally tends to decrease extreme force effects, it produces negative moments at corners, torsional moments in the end zones, substantial redistribution of reaction forces, and a number of other structural phenomena that should be considered in the design.

4.6.2.1.3—Width of Equivalent Interior Strips

C4.6.2.1.3

The width of the equivalent strip of a deck may be taken as specified in Table 4.6.2.1.3-1. Where decks span primarily in the direction parallel to traffic, strips supporting an axle load shall not be taken to be greater than 40.0 in. for open grids and not greater than 144 in. for all other decks where multilane loading is being investigated. For deck overhangs, where applicable, the provisions of Article 3.6.1.3.4 may be used in lieu of the strip width specified in Table 4.6.2.1.3-1 for deck overhangs. The equivalent strips for decks that span primarily in the transverse direction shall not be subject to width limits. The following notation shall apply to Table 4.6.2.1.3-1:

- S = spacing of supporting components (ft)
- h = depth of deck (in.)
- L = span length of deck (ft)
- P = axle load (kip)
- S_b = spacing of grid bars (in.)
- $+M$ = positive moment
- $-M$ = negative moment
- X = distance from load to point of support (ft)

Values provided for equivalent strip widths and strength requirements in the secondary direction are based on past experience. Practical experience and future research work may lead to refinement.

To get the load per unit width of the equivalent strip, divide the total load on one design traffic lane by the calculated strip width.

Table 4.6.2.1.3-1—Equivalent Strips

Type of Deck	Direction of Primary Strip Relative to Traffic	Width of Primary Strip (in.)
Concrete:		
<ul style="list-style-type: none"> • Cast-in-place 	Overhang	$45.0 + 10.0X$
	Either Parallel or Perpendicular	+M: $26.0 + 6.6S$ -M: $48.0 + 3.0S$
<ul style="list-style-type: none"> • Cast-in-place with stay-in-place concrete formwork 	Either Parallel or Perpendicular	+M: $26.0 + 6.6S$ -M: $48.0 + 3.0S$
<ul style="list-style-type: none"> • Precast, post-tensioned 	Either Parallel or Perpendicular	+M: $26.0 + 6.6S$ -M: $48.0 + 3.0S$
Steel:		
<ul style="list-style-type: none"> • Open grid 	Main Bars	$1.25P + 4.0S_b$
<ul style="list-style-type: none"> • Filled or partially filled grid 	Main Bars	Article 4.6.2.1.8 applies
<ul style="list-style-type: none"> • Unfilled, composite grids 	Main Bars	Article 4.6.2.1.8 applies
Wood:		
<ul style="list-style-type: none"> • Prefabricated glulam <ul style="list-style-type: none"> ○ Noninterconnected 	Parallel	$2.0h + 30.0$
	Perpendicular	$2.0h + 40.0$
<ul style="list-style-type: none"> ○ Interconnected 	Parallel	$90.0 + 0.84L$
	Perpendicular	$4.0h + 30.0$
<ul style="list-style-type: none"> • Stress-laminated 	Parallel	$0.8S + 108.0$
	Perpendicular	$10.0S + 24.0$
<ul style="list-style-type: none"> • Spike-laminated <ul style="list-style-type: none"> ○ Continuous decks or interconnected panels 	Parallel	$2.0h + 30.0$
	Perpendicular	$4.0h + 40.0$
<ul style="list-style-type: none"> ○ Noninterconnected panels 	Parallel	$2.0h + 30.0$
	Perpendicular	$2.0h + 40.0$

Wood plank decks shall be designed for the wheel load of the design truck distributed over the tire contact area. For transverse planks, i.e., planks perpendicular to traffic direction:

- If $w_p \geq 10.0$ in., the full plank width shall be assumed to carry the wheel load.
- If $w_p < 10.0$ in., the portion of the wheel load carried by a plank shall be determined as the ratio of w_p and 10.0 in.

Only the wheel load is specified for plank decks. Addition of lane load will cause a negligible increase in force effects; however, it may be added for uniformity of the Code.

For longitudinal planks:

- If $w_p \geq 20.0$ in., the full plank width shall be assumed to carry the wheel load.
- If $w_p < 20.0$ in., the portion of the wheel load carried by a plank shall be determined as the ratio of w_p and 20.0 in.

where:

w_p = plank width (in.)

4.6.2.1.4—Width of Equivalent Strips at Edges of Slabs

4.6.2.1.4a—General

For the purpose of design, the notional edge beam shall be taken as a reduced deck strip width specified herein. Any additional integral local thickening or similar protrusion acting as a stiffener to the deck that is located within the reduced deck strip width can be assumed to act with the reduced deck strip width as the notional edge beam.

4.6.2.1.4b—Longitudinal Edges

Edge beams shall be assumed to support one line of wheels and, where appropriate, a tributary portion of the design lane load.

Where decks span primarily in the direction of traffic, the effective width of a strip, with or without an edge beam, may be taken as the sum of the distance between the edge of the deck and the inside face of the barrier, plus 12.0 in., plus one-quarter of the strip width, specified in either Article 4.6.2.1.3, Article 4.6.2.3, or Article 4.6.2.10, as appropriate, but not exceeding either one-half the full strip width or 72.0 in.

4.6.2.1.4c—Transverse Edges

Transverse edge beams shall be assumed to support one axle of the design truck in one or more design lanes, positioned to produce maximum load effects. Multiple presence factors and the dynamic load allowance shall apply.

The effective width of a strip, with or without an edge beam, may be taken as the sum of the distance between the transverse edge of the deck and the centerline of the first line of support for the deck, usually taken as a girder web, plus one-half of the width of strip as specified in Article 4.6.2.1.3. The effective width shall not exceed the full strip width specified in Article 4.6.2.1.3.

C4.6.2.1.4c

For decks covered by Table A4-1, the total moment acting on the edge beam, including the multiple presence factor and the dynamic load allowance, may be calculated by multiplying the moment per unit width, taken from Table A4-1, by the corresponding full strip width specified in Article 4.6.2.1.3.

4.6.2.1.5—Distribution of Wheel Loads

If the spacing of supporting components in the secondary direction exceeds 1.5 times the spacing in the primary direction, all of the wheel loads shall be considered to be applied to the primary strip, and the provisions of Article 9.7.3.2 may be applied to the secondary direction.

If the spacing of supporting components in the secondary direction is less than 1.5 times the spacing in the primary direction, the deck shall be modeled as a system of intersecting strips.

The width of the equivalent strips in both directions may be taken as specified in Table 4.6.2.1.3-1. Each wheel load shall be distributed between two intersecting strips. The distribution shall be determined as the ratio between the stiffness of the strip and the sum of stiffnesses of the intersecting strips. In the absence of more precise calculations, the strip stiffness, k_s , may be estimated as:

$$k_s = \frac{EI_s}{S^3} \quad (4.6.2.1.5-1)$$

where:

I_s = moment of inertia of the equivalent strip (in.⁴)
 S = spacing of supporting components (in.)

4.6.2.1.6—Calculation of Force Effects

The strips shall be treated as continuous beams or simply supported beams, as appropriate. Span length shall be taken as the center-to-center distance between the supporting components. For the purpose of determining force effects in the strip, the supporting components shall be assumed to be infinitely rigid.

The wheel loads may be modeled as concentrated loads or as patch loads whose length along the span shall be the length of the tire contact area, as specified in Article 3.6.1.2.5, plus the depth of the deck. The strips should be analyzed by classical beam theory.

The design section for negative moments and shear forces, where investigated, may be taken as follows:

- For monolithic construction, closed steel boxes, closed concrete boxes, open concrete boxes without top flanges, and stemmed precast beams, i.e., Cross-sections (b), (c), (d), (e), (f), (g), (h), (i), and (j) from Table 4.6.2.2.1-1, at the face of the supporting component,
- For steel I-beams and steel tub girders, i.e., Cross-sections (a) and (c) from Table 4.6.2.2.1-1, one-quarter the flange width from the centerline of support,

C4.6.2.1.5

This Article attempts to clarify the application of the traditional AASHTO approach with respect to continuous decks.

C4.6.2.1.6

This is a deviation from the traditional approach based on a continuity correction applied to results obtained for analysis of simply supported spans. In lieu of more precise calculations, the unfactored design live load moments for many practical concrete deck slabs can be found in Table A4-1.

For short-spans, the force effects calculated using the footprint could be significantly lower, and more realistic, than force effects calculated using concentrated loads.

Reduction in negative moment and shear replaces the effect of reduced span length in the current code. The design sections indicated may be applied to deck overhangs and to portions of decks between stringers or similar lines of support.

Past practice has been to not check shear in typical decks. A design section for shear is provided for use in nontraditional situations. It is not the intent to investigate shear in every deck.

- For precast I-shaped concrete beams and open concrete boxes with top flanges, i.e., Cross-sections (c) and (k) from Table 4.6.2.2.1-1, one-third the flange width, but not exceeding 15.0 in., from the centerline of support,
- For wood beams, i.e., Cross-section (l) from Table 4.6.2.2.1-1, one-fourth the top beam width from centerline of beam.

For open box beams, each web shall be considered as a separate supporting component for the deck. The distance from the centerline of each web and the adjacent design sections for negative moment shall be determined based on the type of construction of the box and the shape of the top of the web using the requirements outlined above.

4.6.2.1.7—Cross-Sectional Frame Action

Where decks are an integral part of box or cellular cross-sections, flexural and/or torsional stiffnesses of supporting components of the cross-section, i.e., the webs and bottom flange, are likely to cause significant force effects in the deck. Those components shall be included in the analysis of the deck.

If the length of a frame segment is modeled as the width of an equivalent strip, provisions of Articles 4.6.2.1.3, 4.6.2.1.5, and 4.6.2.1.6 may be used.

4.6.2.1.8—Live Load Force Effects for Fully and Partially Filled Grids and for Unfilled Grid Decks Composite with Reinforced Concrete Slabs

Moments in kip-in./in. of deck due to live load may be determined as:

- Main bars perpendicular to traffic:
For $L \leq 120$ in.

C4.6.2.1.7

The model used is essentially a transverse segmental strip, in which flexural continuity provided by the webs and bottom flange is included. Such modeling is restricted to closed cross-sections only. In open-framed structures, a degree of transverse frame action also exists, but it can be determined only by complex, refined analysis.

In normal beam-slab superstructures, cross-sectional frame action may safely be neglected. If the slab is supported by box beams or is integrated into a cellular cross-section, the effects of frame action could be considerable. Such action usually decreases positive moments, but may increase negative moments resulting in cracking of the deck. For larger structures, a three-dimensional analysis may be appropriate. For smaller structures, the analysis could be restricted to a segment of the bridge whose length is the width of an equivalent strip.

Extreme force effects may be calculated by combining the:

- Longitudinal response of the superstructure approximated by classical beam theory, and
- Transverse flexural response modeled as a cross-sectional frame.

C4.6.2.1.8

The moment equations are based on orthotropic plate theory considering vehicular live loads specified in Article 3.6. The equations take into account relevant factored load combinations including truck and tandem loads. The moment equations also account for dynamic load allowance, multiple presence factors, and load

$$M_{transverse} = 1.28D^{0.197}L^{0.459}C \quad (4.6.2.1.8-1)$$

For $L > 120$ in.

$$M_{transverse} = \frac{D^{0.188}(3.7L^{1.35} - 956.3)}{L}(C) \quad (4.6.2.1.8-2)$$

- Main bars parallel to traffic:

For $L \leq 120$ in.

$$M_{parallel} = 0.73D^{0.123}L^{0.64}C \quad (4.6.2.1.8-3)$$

For $L > 120$ in.

$$M_{parallel} = \frac{D^{0.138}(3.1L^{1.429} - 1088.5)}{L}(C) \quad (4.6.2.1.8-4)$$

where:

L = span length from center-to-center of supports (in.)

C = continuity factor; 1.0 for simply supported and 0.8 for continuous spans

D = D_x/D_y

D_x = flexural rigidity of deck in main bar direction (kip-in.²/in.)

D_y = flexural rigidity of deck perpendicular to main bar direction (kip-in.²/in.)

For grid decks, D_x and D_y should be calculated as EI_x and EI_y where E is the modulus of elasticity and I_x and I_y are the moment of inertia per unit width of deck, considering the section as cracked and using the transformed area method for the main bar direction and perpendicular to main bar direction, respectively.

Moments for fatigue assessment may be estimated for all span lengths by reducing Eq. 4.6.2.1.8-1 for main bars perpendicular to traffic or Eq. 4.6.2.1.8-3 for main bars parallel to traffic by a factor of 1.5.

Deflection in units of in. due to vehicular live load may be determined as:

- Main bars perpendicular to traffic:

$$\Delta_{transverse} = \frac{0.0052D^{0.19}L^3}{D_x} \quad (4.6.2.1.8-5)$$

- Main bars parallel to traffic:

$$\Delta_{parallel} = \frac{0.0072D^{0.11}L^3}{D_x} \quad (4.6.2.1.8-6)$$

positioning on the deck surface to produce the largest possible moment.

Negative moment can be determined as maximum simple span positive moment times the continuity factor, C .

The reduction factor of 1.5 in the last sentence of Article 4.6.2.1.8 accounts for smaller dynamic load allowance (15 percent vs. 33 percent), smaller load factor (0.75 vs. 1.75) and no multiple presence (1.0 vs. 1.2) when considering the Fatigue I limit state. Use of Eqs. 4.6.2.1.8-1 and 4.6.2.1.8-3 for all spans is appropriate as Eqs. 4.6.2.1.8-1 and 4.6.2.1.8-3 reflect an individual design truck on short-span lengths while Eqs. 4.6.2.1.8-2 and 4.6.2.1.8-4 reflect the influence of multiple design tandems that control moment envelope on longer span lengths. The approximation produces reasonable estimates of fatigue moments, however, improved estimates can be determined using fatigue truck patch loads in the infinite series formula provided by Higgins (2003).

Actual D_x and D_y values can vary considerably depending on the specific deck design, and using assumed values based only on the general type of deck can lead to unconservative design moments. Flexural rigidity in each direction should be calculated analytically as EI considering the section as cracked and using the transformed area method.

The deflection equations permit calculation of the midspan displacement for a deck under service load. The equations are based on orthotropic plate theory and consider both truck and tandem loads on a simply supported deck.

Deflection may be reduced for decks continuous over three or more supports. A reduction factor of 0.8 is conservative.

4.6.2.1.9—Inelastic Analysis

The inelastic finite element analysis or yield line analysis may be permitted by the Owner.

4.6.2.2—Beam-Slab Bridges

4.6.2.2.1—Application

The provisions of this Article may be applied to straight girder bridges and horizontally curved concrete bridges, as well as horizontally curved steel girder bridges complying with the provisions of Article 4.6.1.2.4. The provisions of this Article may also be used to determine a starting point for some methods of analysis to determine force effects in curved girders of any degree of curvature in plan.

Except as specified in Article 4.6.2.2.5, the provisions of this Article shall be taken to apply to bridges being analyzed for:

- A single lane of loading, or
- Multiple lanes of live load yielding approximately the same force effect per lane.

If one lane is loaded with a special vehicle or evaluation permit vehicle, the design force effect per girder resulting from the mixed traffic may be determined as specified in Article 4.6.2.2.5.

For beam spacing exceeding the range of applicability as specified in tables in Articles 4.6.2.2.2 and 4.6.2.2.3, the live load on each beam shall be the reaction of the loaded lanes based on the lever rule unless specified otherwise herein.

The provisions of Article 3.6.1.1.2 specify that multiple presence factors shall not be used with the approximate load assignment methods other than statical moment or lever arm methods because these factors are already incorporated in the distribution factors.

Bridges not meeting the requirements of this Article shall be analyzed as specified in Article 4.6.3.

The distribution of live load, specified in Articles 4.6.2.2.2 and 4.6.2.2.3, may be used for girders, beams, and stringers, other than multiple steel box beams with concrete decks that meet the following conditions and any other conditions identified in tables of distribution factors as specified herein:

- Width of deck is constant;
- Unless otherwise specified, the number of beams is not less than four;

C4.6.2.2.1

The V-load method is one example of a method of curved bridge analysis which starts with straight girder distribution factors (United States Steel, 1984).

The lever rule involves summing moments about one support to find the reaction at another support by assuming that the supported component is hinged at interior supports.

When using the lever rule on a three-girder bridge, the notional model should be taken as shown in Figure C4.6.2.2.1-1. Moments should be taken about the assumed, or notional, hinge in the deck over the middle girder to find the reaction on the exterior girder.

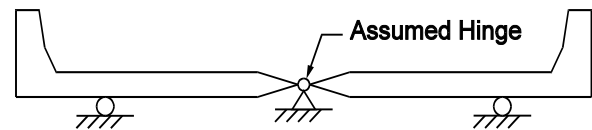

Figure C4.6.2.2.1-1—Notional Model for Applying Lever Rule to Three-Girder Bridges

Provisions in Articles 4.6.2.2.2 and 4.6.2.2.3 that do not appear in earlier editions of the Standard Specifications come primarily from Zokaie et al. (1991). Correction factors for continuity have been deleted for two reasons:

- Correction factors dealing with five percent adjustments were thought to imply misleading levels of accuracy in an approximate method, and
- Analyses of many continuous beam-slab-type bridges indicate that the distribution coefficients for negative moments exceed those obtained for positive moments by approximately ten percent. On the other hand, it has been observed that stresses at or near an internal bearing are reduced due to the fanning of the reaction force. This reduction is about the same magnitude as the increase in distribution factors, hence the two tend to cancel each other out, and thus are omitted from these Specifications.

- Beams are parallel and have approximately the same stiffness;
- Unless otherwise specified, the roadway part of the overhang, d_e , does not exceed 3.0 ft;
- Curvature in plan is less than the limit specified in Article 4.6.1.2.4, or where distribution factors are required in order to implement an acceptable approximate or refined analysis method satisfying the requirements of Article 4.4 for bridges of any degree of curvature in plan; and
- Cross-section is consistent with one of the cross-sections shown in Table 4.6.2.2.1-1.

Where moderate deviations from a constant deck width or parallel beams exist, the distribution factor may either be varied at selected locations along the span or else a single distribution factor may be used in conjunction with a suitable value for beam spacing.

Cast-in-place multicell concrete box girder bridge types may be designed as whole-width structures. Such cross-sections shall be designed for the live load distribution factors in Articles 4.6.2.2.2 and 4.6.2.2.3 for interior girders, multiplied by the number of girders, i.e., webs.

Additional requirements for multiple steel box girders with concrete decks shall be as specified in Article 4.6.2.2.2b.

Where bridges meet the conditions specified herein, permanent loads of and on the deck may be distributed uniformly among the beams and/or stringers.

Live load distribution factors, specified herein, may be used for permit and rating vehicles whose overall width is comparable to the width of the design truck.

The following notation shall apply to tables in Articles 4.6.2.2.2 and 4.6.2.2.3:

- A = area of stringer, beam or girder (in.²)
 b = width of beam (in.)

In Strength Load Combination II, applying a distribution factor procedure to a loading involving a heavy permit load can be overly conservative unless lane-by-lane distribution factors are available. Use of a refined method of analysis will circumvent this situation.

A rational approach may be used to extend the provisions of this Article to bridges with splayed girders. The distribution factor for live load at any point along the span may be calculated by setting the girder spacing in the equations of this Article equal to half the sum of the center-to-center distance between the girder under consideration and the two girders to either side. This will result in a variable distribution factor along the length of the girder. While the variable distribution factor is theoretically correct, it is not compatible with existing line girder computer programs that only allow constant distribution factor. Further simplifications may be used to allow the use of such computer programs. One such simplification involves running the computer program a number of times equal to the number of spans in the bridge. For each run, the girder spacing is set equal to the maximum girder spacing in one span and the results from this run are applied to this span. This approach is guaranteed to result in conservative design. In the past, some jurisdictions applied the latter approach, but used the girder spacing at the 2/3 or 3/4 points of the span; which will also be an acceptable approximation.

Most of the equations for distribution factors were derived for constant deck width and parallel beams. Past designs with moderate exceptions to these two assumptions have performed well when the S/D distribution factors were used. While the distribution factors specified herein are more representative of actual bridge behavior, common sense indicates that some exceptions are still possible, especially if the parameter S is chosen with prudent judgment, or if the factors are appropriately varied at selected locations along the span.

Whole-width design is appropriate for torsionally-stiff cross-sections where load-sharing between girders is extremely high and torsional loads are hard to estimate. Prestressing force should be evenly distributed between girders. Cell width-to-height ratios should be approximately 2:1.

In lieu of more refined information, the St. Venant torsional inertia, J , may be determined as:

- For thin-walled open beam:

$$J = \frac{1}{3} \sum bt^3 \quad (\text{C4.6.2.2.1-1})$$

- For stocky open sections, e.g., prestressed I-beams, T-beams, etc., and solid sections:

$$J = \frac{A^4}{40.0I_p} \quad (\text{C4.6.2.2.1-2})$$

C	=	stiffness parameter
D	=	width of distribution per lane (ft)
d	=	depth of beam or stringer (in.)
d_e	=	horizontal distance from the centerline of the exterior web of exterior beam at deck level to the interior edge of curb or traffic barrier (ft)
e	=	correction factor
g	=	distribution factor
I_p	=	polar moment of inertia (in. ⁴)
J	=	St. Venant's torsional inertia (in. ⁴)
K	=	constant for different types of construction
K_g	=	longitudinal stiffness parameter (in. ⁴)
L	=	span of beam (ft)
N_b	=	number of beams, stringers or girders
N_c	=	number of cells in a concrete box girder
N_L	=	number of design lanes as specified in Article 3.6.1.1.1
S	=	spacing of beams or webs (ft)
t_g	=	depth of steel grid or corrugated steel plank including integral concrete overlay or structural concrete component, less a provision for grinding, grooving, or wear (in.)
t_o	=	depth of structural overlay (in.)
t_s	=	depth of concrete slab (in.)
W	=	edge-to-edge width of bridge (ft)
W_e	=	half the web spacing, plus the total overhang (ft)
θ	=	skew angle (degrees)
μ	=	Poisson's ratio

Unless otherwise stated, the stiffness parameters for area, moments of inertia and torsional stiffness used herein and in Articles 4.6.2.2.2 and 4.6.2.2.3 shall be taken as those of the cross-section to which traffic will be applied, i.e., usually the composite section.

- For closed thin-walled shapes:

$$J = \frac{4A_o^2}{\sum \frac{s}{t}} \quad (\text{C4.6.2.2.1-3})$$

where:

b	=	width of plate element (in.)
t	=	thickness of plate-like element (in.)
A	=	area of cross-section (in. ²)
I_p	=	polar moment of inertia (in. ⁴)
A_o	=	area enclosed by centerlines of elements (in. ²)
s	=	length of a side element (in.)

Eq. C4.6.2.2.1-2 has been shown to substantially underestimate the torsional stiffness of some concrete I-beams and a more accurate, but more complex, approximation can be found in Eby et al. (1973).

The transverse post-tensioning shown for some cross-sections herein is intended to make the units act together. A minimum 0.25 ksi prestress is recommended.

For beams with variable moment of inertia, K_g may be based on average properties.

For bridge types "f," "g," "h," "i," and "j," longitudinal joints between precast units of the cross-section are shown in Table 4.6.2.2.1-1. This type of construction acts as a monolithic unit if sufficiently interconnected. In Article 5.14.4.3.3f, a fully interconnected joint is identified as a flexural shear joint. This type of interconnection is enhanced by either transverse post-tensioning of an intensity specified above or by a reinforced structural overlay, which is also specified in Article 5.14.4.3.3f, or both. The use of transverse mild steel rods secured by nuts or similar unstressed dowels should not be considered sufficient to achieve full transverse flexural continuity unless demonstrated by testing or experience. Generally, post-tensioning is thought to be more effective than a structural overlay if the intensity specified above is achieved.

In some cases, the lower limit of deck slab thickness, t_s , shown in the range of applicability column in tables in Articles 4.6.2.2.2 and 4.6.2.2.3 is less than 7.0 in. The research used to develop the equations in those tables reflects the range of slab thickness shown. Article 9.7.1.1 indicates that concrete decks less than 7.0 in. in thickness should not be used unless approved by the Owner. Lesser values shown in tables in Articles 4.6.2.2.2 and 4.6.2.2.3 are not intended to override Article 9.7.1.1.

The longitudinal stiffness parameter, K_g , shall be taken as:

$$K_g = n(I + Ae_g^2) \tag{4.6.2.2.1-1}$$

in which:

$$n = \frac{E_B}{E_D} \tag{4.6.2.2.1-2}$$

where:

E_B = modulus of elasticity of beam material (ksi)

E_D = modulus of elasticity of deck material (ksi)

I = moment of inertia of beam (in.⁴)

e_g = distance between the centers of gravity of the basic beam and deck (in.)

The parameters A and I in Eq. 4.6.2.2.1-1 shall be taken as those of the noncomposite beam.

The bridge types indicated in tables in Articles 4.6.2.2.2 and 4.6.2.2.3, with reference to Table 4.6.2.2.1-1, may be taken as representative of the type of bridge to which each approximate equation applies.

The load distribution factor equations for bridge type “d”, cast-in-place multicell concrete box girders, were derived by first positioning the vehicle longitudinally, and then transversely, using an I-section of the box. While it would be more appropriate to develop an algorithm to find the peak of an influence surface, using the present factor for the interior girders multiplied by the number of girders is conservative in most cases.

Table C4.6.2.2.1-1 describes how the term L (length) may be determined for use in the live load distribution factor equations given in Articles 4.6.2.2.2 and 4.6.2.2.3.

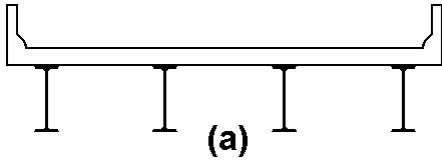
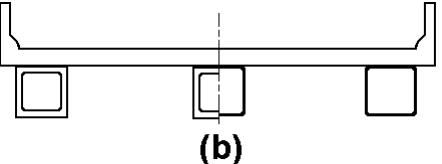
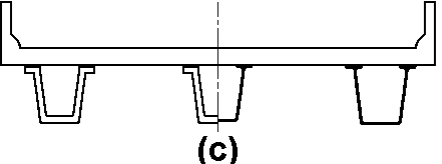

Table C4.6.2.2.1-1— L for Use in Live Load Distribution Factor Equations

Force Effect	L (ft)
Positive Moment	The length of the span for which moment is being calculated
Negative Moment—Near interior supports of continuous spans from point of contraflexure to point of contraflexure under a uniform load on all spans	The average length of the two adjacent spans
Negative Moment—Other than near interior supports of continuous spans	The length of the span for which moment is being calculated
Shear	The length of the span for which shear is being calculated
Exterior Reaction	The length of the exterior span
Interior Reaction of Continuous Span	The average length of the two adjacent spans

Except as permitted by Article 2.5.2.7.1, regardless of the method of analysis used, i.e., approximate or refined, exterior girders of multibeam bridges shall not have less resistance than an interior beam.

In the rare occasion when the continuous span arrangement is such that an interior span does not have any positive uniform load moment (i.e., no uniform load points of contraflexure), the region of negative moment near the interior supports would be increased to the centerline of the span, and the L used in determining the live load distribution factors would be the average of the two adjacent spans.

Table 4.6.2.1-1—Common Deck Superstructures Covered in Articles 4.6.2.2.2 and 4.6.2.2.3

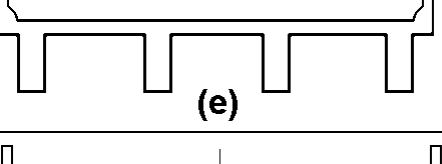
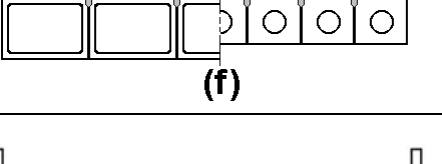
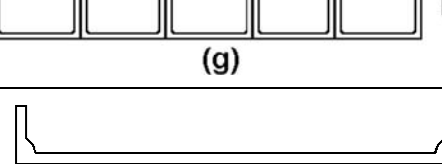
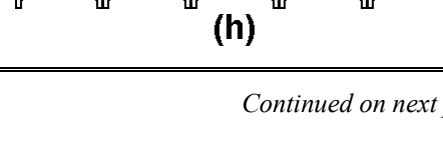
Supporting Components	Type Of Deck	Typical Cross-Section
Steel Beam	Cast-in-place concrete slab, precast concrete slab, steel grid, glued/spiked panels, stressed wood	 (a)
Closed Steel or Precast Concrete Boxes	Cast-in-place concrete slab	 (b)
Open Steel or Precast Concrete Boxes	Cast-in-place concrete slab, precast concrete deck slab	 (c)
Cast-in-Place Concrete Multicell Box	Monolithic concrete	 (d)
Cast-in-Place Concrete Tee Beam	Monolithic concrete	 (e)
Precast Solid, Voided or Cellular Concrete Boxes with Shear Keys	Cast-in-place concrete overlay	 (f)
Precast Solid, Voided, or Cellular Concrete Box with Shear Keys and with or without Transverse Post-Tensioning	Integral concrete	 (g)
Precast Concrete Channel Sections with Shear Keys	Cast-in-place concrete overlay	 (h)

Continued on next page

Table 4.6.2.2.1-1 (continued)—Common Deck Superstructures Covered in Articles 4.6.2.2.2 and 4.6.2.2.3

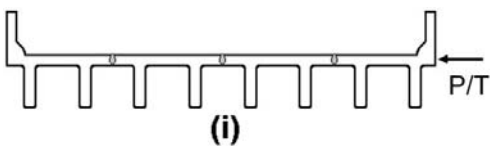
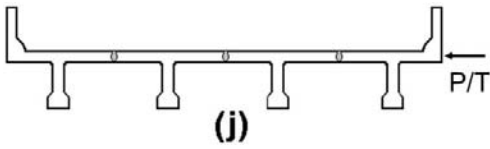
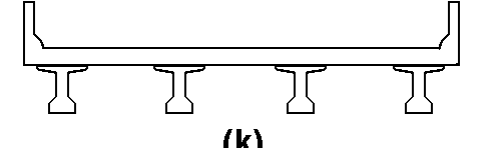
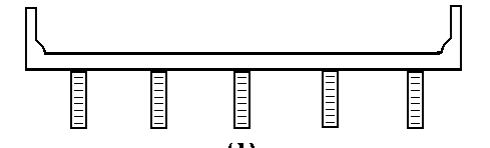
Supporting Components	Type Of Deck	Typical Cross-Section
Precast Concrete Double Tee Section with Shear Keys and with or without Transverse Post-Tensioning	Integral concrete	
Precast Concrete Tee Section with Shear Keys and with or without Transverse Post-Tensioning	Integral concrete	
Precast Concrete I or Bulb-Tee Sections	Cast-in-place concrete, precast concrete	
Wood Beams	Cast-in-place concrete or plank, glued/spiked panels or stressed wood	

For cast-in-place concrete multicell box shown as cross-section Type “d” in Table 4.6.2.2.1-1, the distribution factors in Article 4.6.2.2.2 and 4.6.2.2.3 shall be taken to apply to a notional shape consisting of a web, overhangs of an exterior web, and the associated half flanges between a web under consideration and the next adjacent web or webs.

With the owner’s concurrence, the simplifications provided in Table 4.6.2.2.1-2 may be used:

Table 4.6.2.2.1-2—Constant Values for Articles 4.6.2.2.2 and 4.6.2.2.3

Equation Parameters	Table Reference	Simplified Value			
		a	e	k	f,g,i,j
$\left(\frac{K_g}{12.0Lt_s^3}\right)^{0.1}$	4.6.2.2.2b-1	1.02	1.05	1.09	—
$\left(\frac{K_g}{12.0Lt_s^3}\right)^{0.25}$	4.6.2.2.2e-1	1.03	1.07	1.15	—
$\left(\frac{12.0Lt_s^3}{K_g}\right)^{0.3}$	4.6.2.2.3c-1	0.97	0.93	0.85	—
$\frac{I}{J}$	4.6.2.2.2b-1, 4.6.2.2.3a-1	—	—	—	$0.54\left(\frac{d}{b}\right)+0.16$

4.6.2.2.2—Distribution Factor Method for Moment and Shear

4.6.2.2.2a—Interior Beams with Wood Decks

The live load flexural moment and shear for interior beams with transverse wood decks may be determined by applying the lane fraction specified in Table 4.6.2.2.2a-1 and Eq. 4.6.2.2.2a-1.

When investigation of shear parallel to the grain in wood components is required, the distributed live load shear shall be determined by the following expression:

$$V_{LL} = 0.50[(0.60V_{LU}) + V_{LD}] \quad (4.6.2.2.2a-1)$$

where:

- V_{LL} = distributed live load vertical shear (kips)
- V_{LU} = maximum vertical shear at $3d$ or $L/4$ due to undistributed wheel loads (kips)
- V_{LD} = maximum vertical shear at $3d$ or $L/4$ due to wheel loads distributed laterally as specified herein (kips)

For undistributed wheel loads, one line of wheels is assumed to be carried by one bending member.

Table 4.6.2.2.2a-1—Distribution of Live Load for Moment and Shear in Interior Beams with Wood Decks

Type of Deck	Applicable Cross-Section from Table 4.6.2.2.1-1	One Design Lane Loaded	Two or More Design Lanes Loaded	Range of Applicability
Plank	a, 1	$S/6.7$	$S/7.5$	$S \leq 5.0$
Stressed Laminated	a, 1	$S/9.2$	$S/9.0$	$S \leq 6.0$
Spike Laminated	a, 1	$S/8.3$	$S/8.5$	$S \leq 6.0$
Glued Laminated Panels on Glued Laminated Stringers	a, 1	$S/10.0$	$S/10.0$	$S \leq 6.0$
Glue Laminated Panels on Steel Stringers	a, 1	$S/8.8$	$S/9.0$	$S \leq 6.0$

4.6.2.2.2b—Interior Beams with Concrete Decks

C4.6.2.2.2b

The live load flexural moment for interior beams with concrete decks may be determined by applying the lane fraction specified in Table 4.6.2.2.2b-1.

For the concrete beams, other than box beams, used in multibeam decks with shear keys:

- Deep, rigid end diaphragms shall be provided to ensure proper load distribution; and
- If the stem spacing of stemmed beams is less than 4.0 ft or more than 10.0 ft, a refined analysis complying with Article 4.6.3 shall be used.

For multiple steel box girders with a concrete deck in bridges satisfying the requirements of Article 6.11.2.3, the live load flexural moment may be determined using the appropriate distribution factor specified in Table 4.6.2.2b-1.

Where the spacing of the box girders varies along the length of the bridge, the distribution factor may either be varied at selected locations along the span or else a single distribution factor may be used in conjunction with a suitable value of N_L . In either case, the value of N_L shall be determined as specified in Article 3.6.1.1.1, using the width, w , taken at the section under consideration.

The results of analytical and model studies of simple span multiple box section bridges, reported in Johnston and Mattock (1967), showed that folded plate theory could be used to analyze the behavior of bridges of this type. The folded plate theory was used to obtain the maximum load per girder, produced by various critical combinations of loading on 31 bridges having various spans, numbers of box girders, and numbers of traffic lanes.

Multiple presence factors, specified in Table 3.6.1.1.2-1, are not applied because the multiple factors in past editions of the Standard Specifications were considered in the development of the equation in Table 4.6.2.2b-1 for multiple steel box girders.

The lateral load distribution obtained for simple spans is also considered applicable to continuous structures.

The bridges considered in the development of the equations had interior end diaphragms only, i.e., no interior diaphragms within the spans, and no exterior diaphragms anywhere between boxes. If interior or exterior diaphragms are provided within the span, the transverse load distribution characteristics of the bridge will be improved to some degree. This improvement can be evaluated, if desired, using the analysis methods identified in Article 4.4.

Table 4.6.2.2b-1—Distribution of Live Loads for Moment in Interior Beams

Type of Superstructure	Applicable Cross-Section from Table 4.6.2.2.1-1	Distribution Factors	Range of Applicability
Wood Deck on Wood or Steel Beams	a, l	See Table 4.6.2.2.2a-1	
Concrete Deck on Wood Beams	l	One Design Lane Loaded: $S/12.0$ Two or More Design Lanes Loaded: $S/10.0$	$S \leq 6.0$
Concrete Deck, Filled Grid, Partially Filled Grid, or Unfilled Grid Deck Composite with Reinforced Concrete Slab on Steel or Concrete Beams; Concrete T-Beams, T- and Double T-Sections	a, e, k and also i, j if sufficiently connected to act as a unit	One Design Lane Loaded: $0.06 + \left(\frac{S}{14}\right)^{0.4} \left(\frac{S}{L}\right)^{0.3} \left(\frac{K_g}{12.0 L t_s^3}\right)^{0.1}$ Two or More Design Lanes Loaded: $0.075 + \left(\frac{S}{9.5}\right)^{0.6} \left(\frac{S}{L}\right)^{0.2} \left(\frac{K_g}{12.0 L t_s^3}\right)^{0.1}$	$3.5 \leq S \leq 16.0$ $4.5 \leq t_s \leq 12.0$ $20 \leq L \leq 240$ $N_b \geq 4$ $10,000 \leq K_g \leq 7,000,000$
		use lesser of the values obtained from the equation above with $N_b = 3$ or the lever rule	$N_b = 3$
Cast-in-Place Concrete Multicell Box	d	One Design Lane Loaded: $\left(1.75 + \frac{S}{3.6}\right) \left(\frac{1}{L}\right)^{0.35} \left(\frac{1}{N_c}\right)^{0.45}$ Two or More Design Lanes Loaded: $\left(\frac{13}{N_c}\right)^{0.3} \left(\frac{S}{5.8}\right) \left(\frac{1}{L}\right)^{0.25}$	$7.0 \leq S \leq 13.0$ $60 \leq L \leq 240$ $N_c \geq 3$ If $N_c > 8$ use $N_c = 8$
Concrete Deck on Concrete Spread Box Beams	b, c	One Design Lane Loaded: $\left(\frac{S}{3.0}\right)^{0.35} \left(\frac{Sd}{12.0 L^2}\right)^{0.25}$ Two or More Design Lanes Loaded: $\left(\frac{S}{6.3}\right)^{0.6} \left(\frac{Sd}{12.0 L^2}\right)^{0.125}$	$6.0 \leq S \leq 18.0$ $20 \leq L \leq 140$ $18 \leq d \leq 65$ $N_b \geq 3$
		Use Lever Rule	$S > 18.0$
Concrete Beams used in Multibeam Decks	f	One Design Lane Loaded: $k \left(\frac{b}{33.3L}\right)^{0.5} \left(\frac{I}{J}\right)^{0.25}$ where: $k = 2.5(N_b)^{-0.2} \geq 1.5$	$35 \leq b \leq 60$ $20 \leq L \leq 120$ $5 \leq N_b \leq 20$
	g if sufficiently connected to act as a unit	Two or More Design Lanes Loaded: $k \left(\frac{b}{305}\right)^{0.6} \left(\frac{b}{12.0L}\right)^{0.2} \left(\frac{I}{J}\right)^{0.06}$	

continued on next page

Table 4.6.2.2b-1 (continued)—Distribution of Live Loads for Moment in Interior Beams

Type of Superstructure	Applicable Cross-Section from Table 4.6.2.2.1-1	Distribution Factors	Range of Applicability													
	h	Regardless of Number of Loaded Lanes: S/D where: $C = K(W/L) \leq K$ $D = 11.5 - N_L + 1.4N_L(1 - 0.2C)^2$	Skew $\leq 45^\circ$ $N_L \leq 6$													
	g, i, j if connected only enough to prevent relative vertical displacement at the interface	when $C \leq 5$ $D = 11.5 - N_L$ when $C > 5$ $K = \sqrt{\frac{(1+\mu)I}{J}}$ for preliminary design, the following values of K may be used: <table border="0" style="width: 100%;"> <tr> <td style="width: 80%;">Beam Type</td> <td style="text-align: right;">K</td> </tr> <tr> <td>Nonvoided rectangular beams</td> <td style="text-align: right;">0.7</td> </tr> <tr> <td>Rectangular beams with circular voids:</td> <td style="text-align: right;">0.8</td> </tr> <tr> <td>Box section beams</td> <td style="text-align: right;">1.0</td> </tr> <tr> <td>Channel beams</td> <td style="text-align: right;">2.2</td> </tr> <tr> <td>T-beam</td> <td style="text-align: right;">2.0</td> </tr> <tr> <td>Double T-beam</td> <td style="text-align: right;">2.0</td> </tr> </table>		Beam Type	K	Nonvoided rectangular beams	0.7	Rectangular beams with circular voids:	0.8	Box section beams	1.0	Channel beams	2.2	T-beam	2.0	Double T-beam
Beam Type	K															
Nonvoided rectangular beams	0.7															
Rectangular beams with circular voids:	0.8															
Box section beams	1.0															
Channel beams	2.2															
T-beam	2.0															
Double T-beam	2.0															
Open Steel Grid Deck on Steel Beams	a	One Design Lane Loaded: $S/7.5$ If $t_g < 4.0$ $S/10.0$ If $t_g \geq 4.0$ Two or More Design Lanes Loaded: $S/8.0$ If $t_g < 4.0$ $S/10.0$ If $t_g \geq 4.0$	$S \leq 6.0$ $S \leq 10.5$													
Concrete Deck on Multiple Steel Box Girders	b, c	Regardless of Number of Loaded Lanes: $0.05 + 0.85 \frac{N_L}{N_b} + \frac{0.425}{N_L}$	$0.5 \leq \frac{N_L}{N_b} \leq 1.5$													

4.6.2.2.2c—Interior Beams with Corrugated Steel Decks

The live load flexural moment for interior beams with corrugated steel plank deck may be determined by applying the lane fraction, g , specified in Table 4.6.2.2.2c-1.

Table 4.6.2.2.2c-1—Distribution of Live Load for Moment in Interior Beams with Corrugated Steel Plank Decks

One Design Lane Loaded	Two or More Design Lanes Loaded	Range of Applicability
$S/9.2$	$S/9.0$	$S \leq 5.5$ $t_g \geq 2.0$

4.6.2.2d—Exterior Beams

C4.6.2.2d

The live load flexural moment for exterior beams may be determined by applying the lane fraction, g , specified in Table 4.6.2.2d-1.

The distance, d_e , shall be taken as positive if the exterior web is inboard of the interior face of the traffic railing and negative if it is outboard of the curb or traffic barrier.

In beam-slab bridge cross-sections with diaphragms or cross-frames, the distribution factor for the exterior beam shall not be taken to be less than that which would be obtained by assuming that the cross-section deflects and rotates as a rigid cross-section. The provisions of Article 3.6.1.1.2 shall apply.

This additional investigation is required because the distribution factor for girders in a multigirder cross-section, Types “a,” “e,” and “k” in Table 4.6.2.2.1-1, was determined without consideration of diaphragm or cross-frames. The recommended procedure is an interim provision until research provides a better solution.

The procedure outlined in this section is the same as the conventional approximation for loads on piles.

$$R = \frac{N_L}{N_b} + \frac{X_{ext} \sum e}{\sum x^2} \quad (\text{C4.6.2.2d-1})$$

where:

- R = reaction on exterior beam in terms of lanes
- N_L = number of loaded lanes under consideration
- e = eccentricity of a design truck or a design lane load from the center of gravity of the pattern of girders (ft)
- x = horizontal distance from the center of gravity of the pattern of girders to each girder (ft)
- X_{ext} = horizontal distance from the center of gravity of the pattern of girders to the exterior girder (ft)
- N_b = number of beams or girders

Table 4.6.2.2d-1—Distribution of Live Loads for Moment in Exterior Longitudinal Beams

Type of Superstructure	Applicable Cross-Section from Table 4.6.2.2.1-1	One Design Lane Loaded	Two or More Design Lanes Loaded	Range of Applicability
Wood Deck on Wood or Steel Beams	a, l	Lever Rule	Lever Rule	N/A
Concrete Deck on Wood Beams	l	Lever Rule	Lever Rule	N/A
Concrete Deck, Filled Grid, Partially Filled Grid, or Unfilled Grid Deck Composite with Reinforced Concrete Slab on Steel or Concrete Beams; Concrete T-Beams, T- and Double T-Sections	a, e, k and also i, j if sufficiently connected to act as a unit	Lever Rule	$g = e g_{interior}$ $e = 0.77 + \frac{d_e}{9.1}$	$-1.0 \leq d_e \leq 5.5$
			use lesser of the values obtained from the equation above with $N_b = 3$ or the lever rule	$N_b = 3$
Cast-in-Place Concrete Multicell Box	d	$g = \frac{W_e}{14}$	$g = \frac{W_e}{14}$	$W_e \leq S$
		or the provisions for a whole-width design specified in Article 4.6.2.2.1		
Concrete Deck on Concrete Spread Box Beams	b, c	Lever Rule	$g = e g_{interior}$ $e = 0.97 + \frac{d_e}{28.5}$	$0 \leq d_e \leq 4.5$ $6.0 < S \leq 18.0$
			Use Lever Rule	$S > 18.0$
Concrete Box Beams Used in Multibeam Decks	f, g	$g = e g_{interior}$ $e = 1.125 + \frac{d_e}{30} \geq 1.0$	$g = e g_{interior}$ $e = 1.04 + \frac{d_e}{25} \geq 1.0$	$d_e \leq 2.0$
Concrete Beams Other than Box Beams Used in Multibeam Decks	h	Lever Rule	Lever Rule	N/A
	i, j if connected only enough to prevent relative vertical displacement at the interface			
Open Steel Grid Deck on Steel Beams	a	Lever Rule	Lever Rule	N/A
Concrete Deck on Multiple Steel Box Girders	b, c	As specified in Table 4.6.2.2.2b-1		

4.6.2.2.2e—Skewed Bridges

When the line supports are skewed and the difference between skew angles of two adjacent lines of supports does not exceed 10 degrees, the bending moment in the beams may be reduced in accordance with Table 4.6.2.2.2e-1.

C4.6.2.2.2e

Accepted reduction factors are not currently available for cases not covered in Table 4.6.2.2.2e-1.

Table 4.6.2.2e-1—Reduction of Load Distribution Factors for Moment in Longitudinal Beams on Skewed Supports

Type of Superstructure	Applicable Cross-Section from Table 4.6.2.2.1-1	Any Number of Design Lanes Loaded	Range of Applicability
Concrete Deck, Filled Grid, Partially Filled Grid, or Unfilled Grid Deck Composite with Reinforced Concrete Slab on Steel or Concrete Beams; Concrete T-Beams, T- and Double T- Sections	a, e, k and also i, j if sufficiently connected to act as a unit	$1 - c_1 (\tan \theta)^{1.5}$ $c_1 = 0.25 \left(\frac{K_g}{12.0 L t_s^3} \right)^{0.25} \left(\frac{S}{L} \right)^{0.5}$ If $\theta < 30^\circ$ then $c_1 = 0.0$ If $\theta > 60^\circ$ use $\theta = 60^\circ$	$30^\circ \leq \theta \leq 60^\circ$ $3.5 \leq S \leq 16.0$ $20 \leq L \leq 240$ $N_b \geq 4$
Concrete Deck on Concrete Spread Box Beams, Cast-in-Place Multicell Box Concrete Box Beams and Double T-Sections used in Multibeam Decks	b, c, d, f, g	$1.05 - 0.25 \tan \theta \leq 1.0$ If $\theta > 60^\circ$ use $\theta = 60^\circ$	$0^\circ \leq \theta \leq 60^\circ$

4.6.2.2f—Flexural Moments and Shear in Transverse Floorbeams

If the deck is supported directly by transverse floorbeams, the floorbeams may be designed for loads determined in accordance with Table 4.6.2.2f-1.

The fractions provided in Table 4.6.2.2f-1 shall be used in conjunction with the 32.0-kip design axle load alone. For spacings of floorbeams outside the given ranges of applicability, all of the design live loads shall be considered, and the lever rule may be used.

Table 4.6.2.2f-1—Distribution of Live Load for Transverse Beams for Moment and Shear

Type of Deck	Fraction of Wheel Load to Each Floorbeam	Range of Applicability
Plank	$\frac{S}{4}$	N/A
Laminated Wood Deck	$\frac{S}{5}$	$S \leq 5.0$
Concrete	$\frac{S}{6}$	$S \leq 6.0$
Steel Grid and Unfilled Grid Deck Composite with Reinforced Concrete Slab	$\frac{S}{4.5}$	$t_g \leq 4.0$ $S \leq 5.0$
Steel Grid and Unfilled Grid Deck Composite with Reinforced Concrete Slab	$\frac{S}{6}$	$t_g > 4.0$ $S \leq 6.0$
Steel Bridge Corrugated Plank	$\frac{S}{5.5}$	$t_g \geq 2.0$

4.6.2.2.3—Distribution Factor Method for Shear

4.6.2.2.3a—Interior Beams

The live load shear for interior beams may be determined by applying the lane fractions specified in Table 4.6.2.2.3a-1. For interior beam types not listed in Table 4.6.2.2.3a-1, lateral distribution of the wheel or axle adjacent to the end of span shall be that produced by use of the lever rule.

For concrete box beams used in multibeam decks, if the values of I or J do not comply with the limitations in Table 4.6.2.2.3a-1, the distribution factor for shear may be taken as that for moment.

Table 4.6.2.2.3a-1—Distribution of Live Load for Shear in Interior Beams

Type of Superstructure	Applicable Cross-Section from Table 4.6.2.2.1-1	One Design Lane Loaded	Two or More Design Lanes Loaded	Range of Applicability
Wood Deck on Wood or Steel Beams	a, l	See Table 4.6.2.2.2a-1		
Concrete Deck on Wood Beams	l	Lever Rule	Lever Rule	N/A
Concrete Deck, Filled Grid, Partially Filled Grid, or Unfilled Grid Deck Composite with Reinforced Concrete Slab on Steel or Concrete Beams; Concrete T-Beams, T-and Double T-Sections	a, e, k and also i, j if sufficiently connected to act as a unit	$0.36 + \frac{S}{25.0}$	$0.2 + \frac{S}{12} - \left(\frac{S}{35}\right)^{2.0}$	$3.5 \leq S \leq 16.0$ $20 \leq L \leq 240$ $4.5 \leq t_s \leq 12.0$ $N_b \geq 4$
		Lever Rule	Lever Rule	$N_b = 3$
Cast-in-Place Concrete Multicell Box	d	$\left(\frac{S}{9.5}\right)^{0.6} \left(\frac{d}{12.0L}\right)^{0.1}$	$\left(\frac{S}{7.3}\right)^{0.9} \left(\frac{d}{12.0L}\right)^{0.1}$	$6.0 \leq S \leq 13.0$ $20 \leq L \leq 240$ $35 \leq d \leq 110$ $N_c \geq 3$
Concrete Deck on Concrete Spread Box Beams	b, c	$\left(\frac{S}{10}\right)^{0.6} \left(\frac{d}{12.0L}\right)^{0.1}$	$\left(\frac{S}{7.4}\right)^{0.8} \left(\frac{d}{12.0L}\right)^{0.1}$	$6.0 \leq S \leq 18.0$ $20 \leq L \leq 140$ $18 \leq d \leq 65$ $N_b \geq 3$
		Lever Rule	Lever Rule	$S > 18.0$
Concrete Box Beams Used in Multibeam Decks	f, g	$\left(\frac{b}{130L}\right)^{0.15} \left(\frac{I}{J}\right)^{0.05}$	$\left(\frac{b}{156}\right)^{0.4} \left(\frac{b}{12.0L}\right)^{0.1} \left(\frac{I}{J}\right)^{0.05} \left(\frac{b}{48}\right)$ $\frac{b}{48} \geq 1.0$	$35 \leq b \leq 60$ $20 \leq L \leq 120$ $5 \leq N_b \leq 20$ $25,000 \leq J \leq 610,000$ $40,000 \leq I \leq 610,000$
Concrete Beams Other Than Box Beams Used in Multibeam Decks	h	Lever Rule	Lever Rule	N/A
	i, j if connected only enough to prevent relative vertical displacement at the interface			
Open Steel Grid Deck on Steel Beams	a	Lever Rule	Lever Rule	N/A
Concrete Deck on Multiple Steel Box Beams	b, c	As specified in Table 4.6.2.2.2b-1		

4.6.2.2.3b—Exterior Beams

The live load shear for exterior beams shall be determined by applying the lane fractions specified in Table 4.6.2.2.3b-1. For cases not addressed in Table 4.6.2.2.3a-1 and Table 4.6.2.2.3b-1, the live load distribution to exterior beams shall be determined by using the lever rule.

The parameter d_e shall be taken as positive if the exterior web is inboard of the curb or traffic barrier and negative if it is outboard.

The additional provisions for exterior beams in beam-slab bridges with cross-frames or diaphragms, specified in Articles 4.6.2.2.2d, shall apply.

Table 4.6.2.2.3b-1—Distribution of Live Load for Shear in Exterior Beams

Type of Superstructure	Applicable Cross-Section from Table 4.6.2.2.1-1	One Design Lane Loaded	Two or More Design Lanes Loaded	Range of Applicability
Wood Deck on Wood or Steel Beams	a, l	Lever Rule	Lever Rule	N/A
Concrete Deck on Wood Beams	l	Lever Rule	Lever Rule	N/A
Concrete Deck, Filled Grid, Partially Filled Grid, or Unfilled Grid Deck Composite with Reinforced Concrete Slab on Steel or Concrete Beams; Concrete T-Beams, T- and Double T-Beams	a, e, k and also i, j if sufficiently connected to act as a unit	Lever Rule	$g = e g_{interior}$ $e = 0.6 + \frac{d_e}{10}$	$-1.0 \leq d_e \leq 5.5$
			Lever Rule	$N_b = 3$
Cast-in-Place Concrete Multicell Box	d	Lever Rule	$g = e g_{interior}$ $e = 0.64 + \frac{d_e}{12.5}$	$-2.0 \leq d_e \leq 5.0$
			or the provisions for a whole-width design specified in Article 4.6.2.2.1	
Concrete Deck on Concrete Spread Box Beams	b, c	Lever Rule	$g = e g_{interior}$ $e = 0.8 + \frac{d_e}{10}$	$0 \leq d_e \leq 4.5$
			Lever Rule	$S > 18.0$
Concrete Box Beams Used in Multibeam Decks	f, g	$g = e g_{interior}$ $e = 1.25 + \frac{d_e}{20} \geq 1.0$	$g = e g_{interior} \left(\frac{48}{b} \right)$ $\frac{48}{b} \leq 1.0$ $e = 1 + \left(\frac{d_e + \frac{b}{12} - 2.0}{40} \right)^{0.5} \geq 1.0$	$d_e \leq 2.0$ $35 \leq b \leq 60$
Concrete Beams Other Than Box Beams Used in Multibeam Decks	h	Lever Rule	Lever Rule	N/A
	i, j if connected only enough to prevent relative vertical displacement at the interface			
Open Steel Grid Deck on Steel Beams	a	Lever Rule	Lever Rule	N/A
Concrete Deck on Multiple Steel Box Beams	b, c	As specified in Table 4.6.2.2.2b-1		

4.6.2.2.3c—Skewed Bridges

Shear in the exterior beam at the obtuse corner of the bridge shall be adjusted when the line of support is skewed. The value of the correction factor shall be obtained from Table 4.6.2.2.3c-1. It is applied to the lane fraction specified in Table 4.6.2.2.3a-1 for interior beams and in Table 4.6.2.2.3b-1 for exterior beams. This factor should not be applied in addition to modeling skewed supports.

In determining the end shear in multibeam bridges, the skew correction at the obtuse corner shall be applied to all the beams.

C4.6.2.2.3c

Verifiable correction factors are not available for cases not covered in Table 4.6.2.2.3c-1.

The equal treatment of all beams in a multibeam bridge is conservative regarding positive reaction and shear. However, it is not necessarily conservative regarding uplift in the case of large skew and short exterior spans of continuous beams. A supplementary investigation of uplift should be considered using the correction factor from Table 4.6.2.2.3c-1, i.e., the terms other than 1.0, taken as negative for the exterior beam at the acute corner.

Table 4.6.2.2.3c-1—Correction Factors for Load Distribution Factors for Support Shear of the Obtuse Corner

Type of Superstructure	Applicable Cross-Section from Table 4.6.2.2.1-1	Correction Factor	Range of Applicability
Concrete Deck, Filled Grid, Partially Filled Grid, or Unfilled Grid Deck Composite with Reinforced Concrete Slab on Steel or Concrete Beams; Concrete T-Beams, T- and Double T-Section	a, e, k and also i, j if sufficiently connected to act as a unit	$1.0 + 0.20 \left(\frac{12.0 L t_s^3}{K_g} \right)^{0.3} \tan \theta$	$0^\circ \leq \theta \leq 60^\circ$ $3.5 \leq S \leq 16.0$ $20 \leq L \leq 240$ $N_b \geq 4$
Cast-in-Place Concrete Multicell Box	d	$1.0 + \left(0.25 + \frac{12.0 L}{70 d} \right) \tan \theta$	$0^\circ < \theta \leq 60^\circ$ $6.0 < S \leq 13.0$ $20 \leq L \leq 240$ $35 \leq d \leq 110$ $N_c \geq 3$
Concrete Deck on Spread Concrete Box Beams	b, c	$1.0 + \frac{\sqrt{L d}}{6 S} \tan \theta$	$0^\circ < \theta \leq 60^\circ$ $6.0 \leq S \leq 11.5$ $20 \leq L \leq 140$ $18 \leq d \leq 65$ $N_b \geq 3$
Concrete Box Beams Used in Multibeam Decks	f, g	$1.0 + \frac{12.0 L}{90 d} \sqrt{\tan \theta}$	$0^\circ < \theta \leq 60^\circ$ $20 \leq L \leq 120$ $17 \leq d \leq 60$ $35 \leq b \leq 60$ $5 \leq N_b \leq 20$

4.6.2.2.4—Curved Steel Bridges

Approximate analysis methods may be used for analysis of curved steel bridges. The Engineer shall ascertain that the approximate analysis method used is appropriate by confirming that the method satisfies the requirements stated in Article 4.4.

In curved systems, consideration should be given to placing parapets, sidewalks, barriers and other heavy line loads at their actual location on the bridge. Wearing surface and other distributed loads may be assumed uniformly distributed to each girder in the cross-section.

C4.6.2.2.4

The V-load method (United States Steel, 1984) has been a widely used approximate method for analyzing horizontally curved steel I-girder bridges. The method assumes that the internal torsional load on the bridge—resulting solely from the curvature—is resisted by self-equilibrating sets of shears between adjacent girders. The V-load method does not directly account for sources of torque other than curvature and the method does not account for the horizontal shear stiffness of the concrete deck. The method is only valid for loads such as normal highway loadings. For exceptional loadings, a more refined analysis is required. The method assumes a linear

distribution of girder shears across the bridge section; thus, the girders at a given cross-section should have approximately the same vertical stiffness. The V-load method is also not directly applicable to structures with reverse curvature or to a closed-framed system with horizontal lateral bracing near, or in the plane of one or both flanges. The V-load method does not directly account for girder twist; thus, lateral deflections, which become important on bridges with large spans and/or sharp skews and vertical deflections, may be significantly underestimated. In certain situations, the V-load method may not detect uplift at end bearings. The method is best suited for preliminary design, but may also be suitable for final design of structures with radial supports or supports skewed less than approximately 10 degrees.

The M/R method provides a means to account for the effect of curvature in curved box girder bridges. The method and suggested limitations on its use are discussed by Tung and Fountain (1970).

Vertical reactions at interior supports on the concave side of continuous-span bridges may be significantly underestimated by both the V-load and M/R methods.

Live load distribution factors for use with the V-load and M/R methods may be determined using the appropriate provisions of Article 4.6.2.2.

Strict rules and limitations on the applicability of both of these approximate methods do not exist. The Engineer must determine when approximate methods of analysis are appropriate.

4.6.2.2.5—Special Loads with Other Traffic

Except as specified herein, the provisions of this Article may be applied where the approximate methods of analysis for the analysis of beam-slab bridges specified in Article 4.6.2.2 and slab-type bridges specified in Article 4.6.2.3 are used. The provisions of this Article shall not be applied where either:

- the lever rule has been specified for both single lane and multiple lane loadings, or
- the special requirement for exterior girders of beam-slab bridge cross-sections with diaphragms specified in Article 4.6.2.2.2d has been utilized for simplified analysis.

Force effects resulting from heavy vehicles in one lane with routine traffic in adjacent lanes, such as might be considered with Load Combination Strength II in Table 3.4.1-1 may be determined as:

$$G = G_p \left(\frac{g_l}{Z} \right) + G_D \left(g_m - \frac{g_l}{Z} \right) \quad (4.6.2.2.4-1)$$

C4.6.2.2.5

Because the number of loaded lanes used to determine the multiple lane live load distribution factor, g_m , is not known, the multiple lane multiple presence factor, m , is implicitly set equal to 1.0 in this equation, which assumes only two lanes are loaded, resulting in a conservative final force effect over using the multiple presence factors for three or more lanes loaded.

The factor Z is used to distinguish between situations where the single lane live load distribution factor was determined from a specified algebraic equation and situations where the lever rule was specified for the determination of the single lane live load distribution factor. In the situation where an algebraic equation was specified, the multiple presence factor of 1.20 for a single lane loaded has been included in the algebraic equation and must be removed by using $Z = 1.20$ in Eq. 4.6.2.2.4-1 so that the distribution factor can be utilized in Eq. 4.6.2.2.4-1 to determine the force effect resulting from a multiple lane loading.

This formula was developed from a similar formula presented without investigation by Modjeski and Masters, Inc. (1994) in a report to the Pennsylvania Department of Transportation in 1994, as was examined in Zokaie (1998).

where:

- G = final force effect applied to a girder (kip or kip-ft)
 G_p = force effect due to overload truck (kip or kip-ft)
 g_1 = single lane live load distribution factor
 G_D = force effect due to design loads (kip or kip-ft)
 g_m = multiple lane live load distribution factor
 Z = a factor taken as 1.20 where the lever rule was not utilized, and 1.0 where the lever rule was used for a single lane live load distribution factor

4.6.2.3—Equivalent Strip Widths for Slab-Type Bridges

C4.6.2.3

This Article shall be applied to the types of cross-sections shown schematically in Table 4.6.2.3-1. For the purpose of this Article, cast-in-place voided slab bridges may be considered as slab bridges.

The equivalent width of longitudinal strips per lane for both shear and moment with one lane, i.e., two lines of wheels, loaded may be determined as:

$$E = 10.0 + 5.0\sqrt{L_1 W_1} \quad (4.6.2.3-1)$$

In Eq. 4.6.2.3-1, the strip width has been divided by 1.20 to account for the multiple presence effect.

The equivalent width of longitudinal strips per lane for both shear and moment with more than one lane loaded may be determined as:

$$E = 84.0 + 1.44\sqrt{L_1 W_1} \leq \frac{12.0W}{N_L} \quad (4.6.2.3-2)$$

where:

- E = equivalent width (in.)
 L_1 = modified span length taken equal to the lesser of the actual span or 60.0 (ft)
 W_1 = modified edge-to-edge width of bridge taken to be equal to the lesser of the actual width or 60.0 for multilane loading, or 30.0 for single-lane loading (ft)
 W = physical edge-to-edge width of bridge (ft)
 N_L = number of design lanes as specified in Article 3.6.1.1.1

For skewed bridges, the longitudinal force effects may be reduced by the factor r :

$$r = 1.05 - 0.25 \tan \theta \leq 1.00 \quad (4.6.2.3-3)$$

where:

- θ = skew angle (degrees)

Table 4.6.2.3-1—Typical Schematic Cross-Section

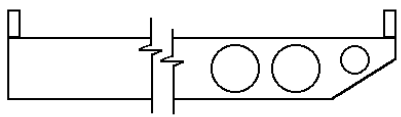
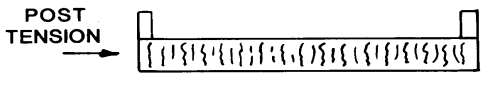
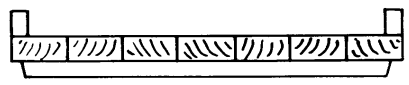
Supporting Components	Type of Deck	Typical Cross-Section
Cast-in-Place Concrete Slab or Voided Slab	Monolithic	 (a)
Stressed Wood Deck	Integral Wood	 (b)
Glued/Spiked Wood Panels with Spreader Beam	Integral Wood	 (c)

4.6.2.4—Truss and Arch Bridges

The lever rule may be used for the distribution of gravity loads in trusses and arches when analyzed as planar structures. If a space analysis is used, either the lever rule or direct loading through the deck or deck system may be used.

Where loads, other than the self-weight of the members and wind loads there on, are transmitted to the truss at the panel points, the truss may be analyzed as a pin-connected assembly.

4.6.2.5—Effective Length Factor, K

Physical column lengths shall be multiplied by an effective length factor, K , to compensate for rotational and translational boundary conditions other than pinned ends.

In the absence of a more refined analysis, where lateral stability is provided by diagonal bracing or other suitable means, the effective length factor in the braced plane, K , for the compression members in triangulated trusses, trusses, and frames may be taken as:

- For bolted or welded end connections at both ends: $K = 0.750$
- For pinned connections at both ends: $K = 0.875$

C4.6.2.5

Equations for the compressive resistance of columns and moment magnification factors for beam-columns include a factor, K , which is used to modify the length according to the restraint at the ends of the column against rotation and translation.

K is the ratio of the effective length of an idealized pin-end column to the actual length of a column with various other end conditions. KL represents the length between inflection points of a buckled column influenced by the restraint against rotation and translation of column ends. Theoretical values of K , as provided by the Structural Stability Research Council, are given in Table C4.6.2.5-1 for some idealized column end conditions.

- For single angles, regardless of end connection: $K = 1.0$

Vierendeel trusses shall be treated as unbraced frames.

Table C4.6.2.5-1—Effective Length Factors, K

Buckled shape of column is shown by dashed line	(a)	(b)	(c)	(d)	(e)	(f)
Theoretical K value	0.5	0.7	1.0	1.0	2.0	2.0
Design value of K when ideal conditions are approximated	0.65	0.80	1.0	1.2	2.1	2.0
End condition code		Rotation fixed Rotation free	Rotation fixed Rotation free	Translation fixed Translation fixed	Translation fixed Translation free	Translation free Translation free

Because actual column end conditions seldom comply fully with idealized restraint conditions against rotation and translation, the design values suggested by the Structural Stability Research Council are higher than the idealized values.

Lateral stability of columns in continuous frames, unbraced by attachment to shear walls, diagonal bracing, or adjacent structures, depends on the flexural stiffness of the rigidly connected beams. Therefore, the effective length factor, K , is a function of the total flexural restraint provided by the beams at the ends of the column. If the stiffness of the beams is small in relation to that of the column, the value of K could exceed 2.0.

Single angles are loaded through one leg and are subject to eccentricity and twist, which is often not recognized. K is set equal to 1.0 for these members to more closely match the strength provided in the Guide for Design of Steel Transmission Towers (ASCE Manual No. 52, 1971).

Assuming that only elastic action occurs and that all columns buckle simultaneously, it can be shown that (Chen and Liu, 1991; ASCE Task Committee on Effective Length, 1997):

For braced frames:

$$\frac{G_a G_b}{4} \left(\frac{\pi}{K} \right)^2 + \frac{G_a + G_b}{2} \left(1 - \frac{\frac{\pi}{K}}{\tan \left(\frac{\pi}{K} \right)} \right) + \frac{2 \tan \left(\frac{\pi}{2K} \right)}{\frac{\pi}{K}} = 1 \tag{C4.6.2.5-1}$$

For unbraced frames:

$$\frac{G_a G_b \left(\frac{\pi}{K} \right)^2 - 36}{6(G_a + G_b)} = \frac{\frac{\pi}{K}}{\tan \left(\frac{\pi}{K} \right)} \quad (\text{C4.6.2.5-2})$$

where subscripts *a* and *b* refer to the two ends of the column under consideration

in which:

$$G = \frac{\Sigma \left(\frac{E_c I_c}{L_c} \right)}{\Sigma \left(\frac{E_g I_g}{L_g} \right)} \quad (\text{C4.6.2.5-3})$$

where:

- Σ = summation of the properties of components rigidly connected to an end of the column in the plane of flexure
- E_c = modulus of elasticity of column (ksi)
- I_c = moment of inertia of column (in.⁴)
- L_c = unbraced length of column (in.)
- E_g = modulus of elasticity of beam or other restraining member (ksi)
- I_g = moment of inertia of beam or other restraining member (in.⁴)
- L_g = unsupported length of beam or other restraining member (in.)
- K = effective length factor for the column under consideration

Figures C4.6.2.5-1 and C4.6.2.5-2 are graphical representations of the relationship among K , G_a , and G_b for Eqs. C4.6.2.5-1 and C4.6.2.5-2, respectively. The figures can be used to obtain values of K directly.

Eqs. C4.6.2.5-1, C4.6.2.5-2, and the alignment charts in Figures C4.6.2.5-1 and C4.6.2.5-2 are based on assumptions of idealized conditions. The development of the chart and formula can be found in textbooks such as Salmon and Johnson (1990) and Chen and Lui (1991). When actual conditions differ significantly from these idealized assumptions, unrealistic designs may result. Galambos (1988), Yura (1971), Disque (1973), Duan and Chen (1988), and AISC (1993) may be used to evaluate end conditions more accurately.

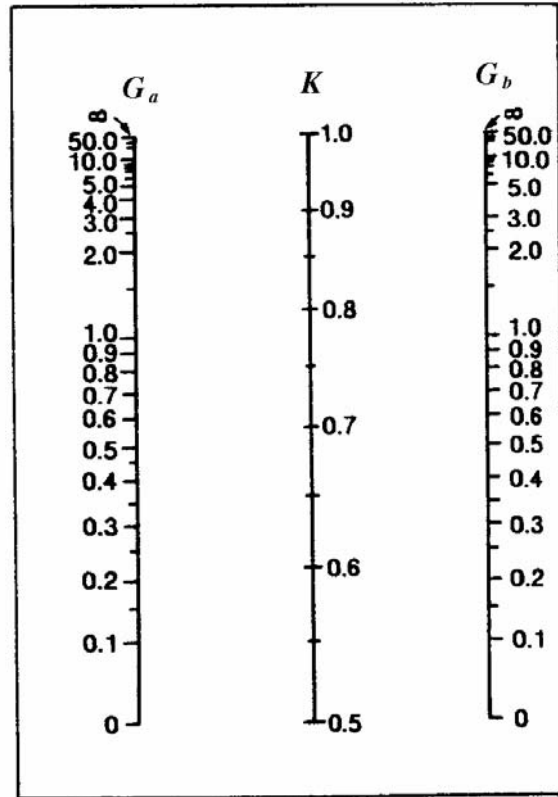

Figure C4.6.2.5-1—Alignment Chart for Determining Effective Length Factor, K , for Braced Frames

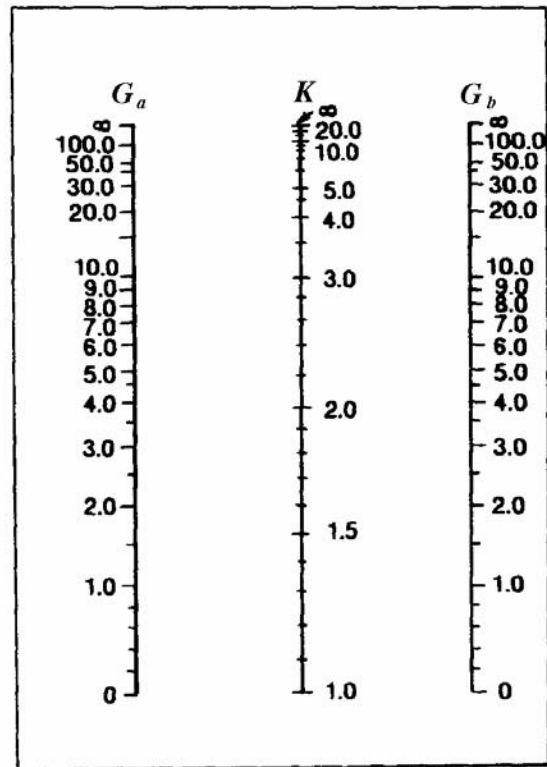

Figure C4.6.2.5-2—Alignment Chart for Determining Effective Length Factor, K , for Unbraced Frames

The following applies to the use of Figures C4.6.2.5-1 and C4.6.2.5-2:

- For column ends supported by but not rigidly connected to a footing or foundation, G is theoretically equal to infinity, but unless actually designed as a true frictionless pin, may be taken equal to 10 for practical design. If the column end is rigidly attached to a properly designed footing, G may be taken equal to 1.0. Smaller values may be taken if justified by analysis.
- In computing effective length factors for members with monolithic connections, it is important to properly evaluate the degree of fixity in the foundation using engineering judgment. In absence of a more refined analysis, the following values can be used:

Condition	G
Footing anchored on rock	1.5
Footing not anchored on rock	3.0
Footing on soil	5.0
Footing on multiple rows of end bearing piles	1.0

In lieu of the alignment charts, the following alternative K -factor equations (Duan, King, and Chen, 1993) may be used.

For braced frames:

$$K = 1 - \frac{1}{5 + 9G_a} - \frac{1}{5 + 9G_b} - \frac{1}{10 + G_a G_b} \quad (\text{C4.6.2.5-4})$$

For unbraced frames:

- For $K < 2$

$$K = 4 - \frac{1}{1 + 0.2G_a} - \frac{1}{1 + 0.2G_b} - \frac{1}{1 + 0.01G_a G_b} \quad (\text{C4.6.2.5-5})$$

- For $K \geq 2$

$$K = \frac{2\pi a}{0.9 + \sqrt{0.81 + 4ab}} \quad (\text{C4.6.2.5-6})$$

in which:

$$a = \frac{G_a G_b}{G_a + G_b} + 3 \quad (\text{C4.6.2.5-7})$$

$$b = \frac{36}{G_a + G_b} + 6 \quad (\text{C4.6.2.5-8})$$

4.6.2.6—Effective Flange Width

4.6.2.6.1—General

Unless specified otherwise in this Article or in Articles 4.6.2.6.2, 4.6.2.6.3, or 4.6.2.6.5, the effective flange width of a concrete deck slab in composite or monolithic construction may be taken as the tributary width perpendicular to the axis of the member for determining cross-section stiffnesses for analysis and for determining flexural resistances. The effective flange width of orthotropic steel decks shall be as specified in Article 4.6.2.6.4. For the calculation of live load deflections, where required, the provisions of Article 2.5.2.6.2 shall apply.

Where a structurally continuous concrete barrier is present and is included in the structural analysis as permitted in Article 4.5.1, the deck slab overhang width used for the analysis as well as for checking the composite girder resistance may be extended by:

$$\Delta w = \frac{A_b}{2t_s} \quad (4.6.2.6.1-1)$$

where:

A_b = cross-sectional area of the barrier (in.²)
 t_s = thickness of deck slab (in.)

The slab effective flange width in composite girder and/or stringer systems or in the chords of composite deck trusses may be taken as one-half the distance to the adjacent stringer or girder on each side of the component, or one-half the distance to the adjacent stringer or girder plus the full overhang width. Otherwise, the slab effective flange width should be determined by a refined analysis when:

- the composite or monolithic member cross-section is subjected to significant combined axial force and bending, with the exception that forces induced by restraint of thermal expansion may be determined in beam-slab systems using the slab tributary width,
- the largest skew angle θ in the bridge system is greater than 75 degrees, where θ is the angle of a bearing line measured relative to a normal to the centerline of a longitudinal component,
- the slab spans longitudinally between transverse floorbeams, or

Eq. C4.6.2.5-5 is used first. If the value of K calculated by Eq. C4.6.2.5-5 is greater than 2, Eq. C4.6.2.5-6 is used. The values for K calculated using Eqs. C4.6.2.5-5 and C4.6.2.5-6 are a good fit with results from the alignment chart Eqs. C4.6.2.5-1, C4.6.2.5-2, C4.6.2.5-3, and allow an Engineer to perform a direct noniterative solution for K .

C4.6.2.6.1

Longitudinal stresses are distributed across the deck of composite and monolithic flexural members by in-plane shear stresses. Due to the corresponding shear deformations, plane sections do not remain plane and the longitudinal stresses across the deck are not uniform. This phenomenon is referred to as shear lag. The effective flange width is the width of the deck over which the assumed uniformly distributed longitudinal stresses result approximately in the same deck force and member moments calculated from elementary beam theory assuming plane sections remain plane, as are produced by the nonuniform stress distribution.

The provisions of this Article apply to all longitudinal flexural members composite or monolithic with a deck slab, including girders and stringers. They are based on finite element studies of various bridge types and configurations, corroborated by experimental tests, and sensitivity analysis of various candidate regression equations (Chen et al., 2005). Chen et al. (2005) found that bridges with larger L/S (ratio of span length to girder spacing) consistently exhibited an effective width b_e equal to the tributary width b . Nonskewed bridges with $L/S = 3.1$, the smallest value of L/S considered in the Chen et al. (2005) study, exhibited $b_e = b$ in the maximum positive bending regions and approximately $b_e = 0.9b$ in the maximum negative bending regions under service limit state conditions. However, they exhibited $b_e = b$ in these regions in all cases at the strength limit state. Bridges with large skew angles often exhibited $b_e < b$ in both the maximum positive and negative moment regions, particularly in cases with small L/S . However, when various potential provisions were assessed using the Rating Factor (RF) as a measure of impact, the influence of using full width ($b_e = b$) was found to be minimal. Therefore, the use of the tributary width is justified in all cases within the limits specified in this Article. The Chen et al. (2005) study demonstrated that there is no significant relationship between the slab effective width and the slab thickness, as implied by previous Specifications.

These provisions are considered applicable for skew angles less than or equal to 75 degrees, L/S greater than or equal to 2.0 and overhang widths less than or equal to $0.5S$. In unusual cases where these limits are violated, a refined analysis should be used to determine the slab effective width. Furthermore, these provisions are

- the slab is designed for two-way action.

considered applicable for slab-beam bridges with unequal skew angles of the bearing lines, splayed girders, horizontally curved girders, cantilever spans, and various unequal span lengths of continuous spans, although these parameters have not been investigated extensively in studies to date. These recommendations are based on the fact that the participation of the slab in these broader parametric cases is fundamentally similar to the participation of the slab in the specific parametric cases that have been studied.

The use of one-half the distance to the adjacent stringer or girder in calculating the effective width of the main girders in composite girder and/or stringer systems or the truss chords in composite deck trusses is a conservative assumption for the main structural components, since typically a larger width of the slab can be expected to participate with the main girders or truss chords. However, this tributary width assumption may lead to an underestimation of the shear connector requirements and a lack of consideration of axial forces and bending moments in the composite stringers or girders due to the global effects. To utilize a larger slab width for the main girders or truss chords, a refined analysis should be considered.

The specific cases in which a refined analysis is recommended are so listed because they are significantly beyond the conventional application of the concept of a slab effective width. These cases include tied arches where the deck slab is designed to contribute to the resistance of the tie girders and cable stayed bridges with a composite deck slab. Chen et al. (2005) provides a few case study results for simplified lower-bound slab effective widths in composite deck systems of cable stayed bridges with certain specific characteristics.

4.6.2.6.2—Segmental Concrete Box Beams and Single-Cell, Cast-in-Place Box Beams

The effective flange width may be assumed equal to the physical flange width if:

- $b \leq 0.1 l_i$
- $b \leq 0.3 d_o$

Otherwise, the effective width of outstanding flanges may be taken as specified in Figures 4.6.2.6.2-1 through 4.6.2.6.2-4, where:

- d_o = depth of superstructure (in.)
 b = physical flange width on each side of the web, e.g., b_1 , b_2 , and b_3 , as shown in Figure 4.6.2.6.2-3 (in.)

C4.6.2.6.2

One possible alternative to the procedure specified in this Article is contained in Clause 3-10.2 of the 1991 Ontario Highway Bridge Design Code, which provides an equation for determining the effective flange width for use in calculating flexural resistances and stresses.

Superposition of local two-way slab flexural stresses due to wheel loads and the primary longitudinal flexural stresses is not normally required.

The effective flange widths b_m and b_s are determined as the product of the coefficient in Figure 4.6.2.6.2-2 and the physical distance b , as indicated in Figure 4.6.2.6.2-3.

- b_e = effective flange width corresponding to the particular position of the section of interest in the span as specified in Figure 4.6.2.6.2-1 (in.)
- b_m = effective flange width for interior portions of a span as determined from Figure 4.6.2.6.2-2; a special case of b_e (in.)
- b_s = effective flange width at interior support or for cantilever arm as determined from Figure 4.6.2.6.2-2; a special case of b_e (in.)
- a = portion of span subject to a transition in effective flange width taken as the lesser of the physical flange width on each side of the web shown in Figure 4.6.2.6.2-3 or one quarter of the span length (in.)
- ℓ_i = a notional span length specified in Figure 4.6.2.6.2-1 for the purpose of determining effective flange widths using Figure 4.6.2.6.2-2

The following interpretations apply:

- In any event, the effective flange width shall not be taken as greater than the physical width.
- The effects of unsymmetrical loading on the effective flange width may be disregarded.
- The value of b_s shall be determined using the greater of the effective span lengths adjacent to the support.
- If b_m is less than b_s in a span, the pattern of the effective width within the span may be determined by the connecting line of the effective widths b_s at adjoining support points.

For the superposition of local and global force effects, the distribution of stresses due to the global force effects may be assumed to have a straight line pattern in accordance with Figure 4.6.2.6.2-3c. The linear stress distribution should be determined from the constant stress distribution using the conditions that the flange force remains unchanged and that the maximum width of the linear stress distribution on each side of a web is 2.0 times the effective flange width.

The section properties for normal forces may be based on the pattern according to Figure 4.6.2.6.2-4 or determined by more rigorous analysis.

If the linear stress distributions intersect a free edge or each other before reaching the maximum width, the linear stress distribution is a trapezoid; otherwise, it is a triangle. This is shown in Figure 4.6.2.6.2-3c.

Figure 4.6.2.6.2-4 is intended only for calculation of resistance due to anchorage of post-tensioning tendons and other concentrated forces and may be disregarded in the general analysis to determine force effects.

System		Pattern of b_m/b
Single-Span Girder $\ell_i = 1.0\ell$		
Continuous Girder	End Span $\ell_i = 0.8\ell$	
	Interior Span $\ell_i = 0.6\ell$	
Cantilever Arm $\ell_i = 1.5\ell$		

Figure 4.6.2.6.2-1—Pattern of Effective Flange Width, b_m , b_s , and b

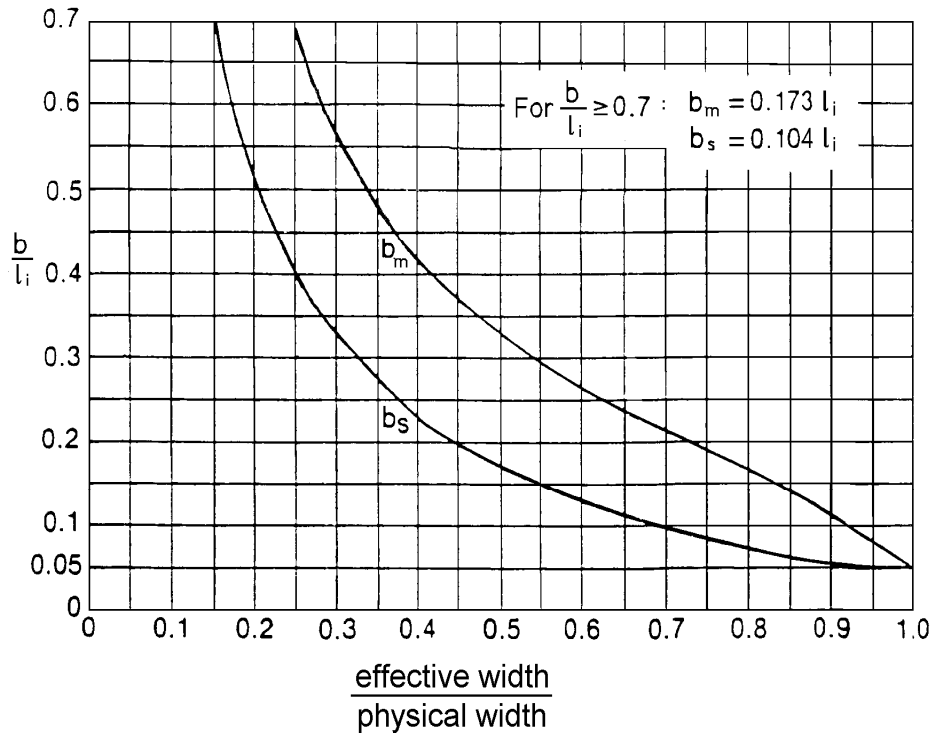

Figure 4.6.2.6.2-2—Values of the Effective Flange Width Coefficients for b_m and b_s for the Given Values of b/l_i

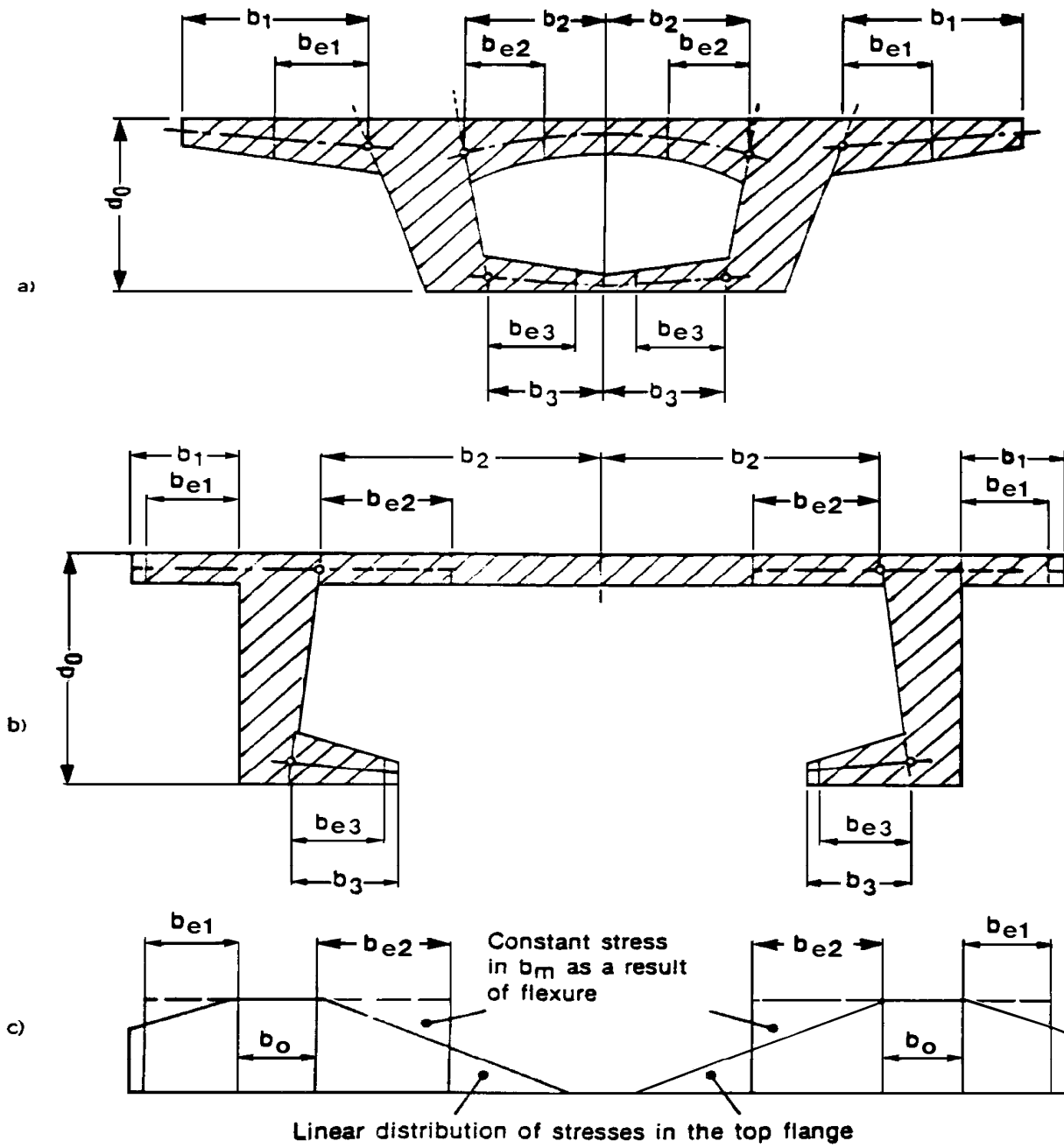

Figure 4.6.2.6.2-3—Cross-Sections and Corresponding Effective Flange Widths, b_e , for Flexure and Shear

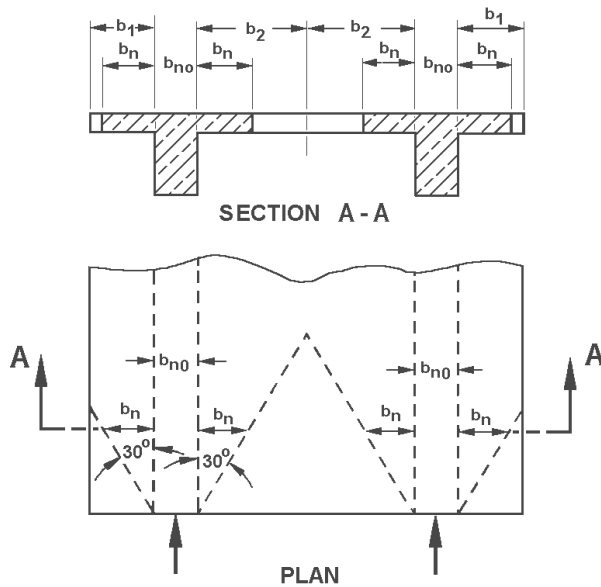

Figure 4.6.2.6.2-4—Effective Flange Widths, b_n , for Normal Forces

4.6.2.6.3—Cast-in-Place Multicell Superstructures

The effective width for cast-in-place multiweb cellular superstructures may be taken to be as specified in Article 4.6.2.6.1, with each web taken to be a beam, or it may be taken to be the full width of the deck slab. In the latter case, the effects of shear lag in the end zones shall be investigated.

4.6.2.6.4—Orthotropic Steel Decks

The effective width need not be determined when using refined analysis as specified in Article 4.6.3.2.4. For simplified analysis, the effective width of the deck, including the deck plate and ribs, acting as the top flange of a longitudinal superstructure component or a transverse beam may be taken as:

- $L/B \geq 5$: fully effective
- $L/B < 5$: $b_{od} = \frac{1}{5}L$

where:

- L = span length of the orthotropic girder or transverse beam (in.)
- B = spacing between orthotropic girder web plates or transverse beams (in.)
- b_{od} = effective width of orthotropic deck (in.)

C4.6.2.6.4

Consideration of effective width of the deck plate can be avoided by application of refined analysis methods.

The procedures in *Design Manual for Orthotropic Steel Plate Deck Bridges* (AISC, 1963) may be used as an acceptable means of simplified analysis; however, it has been demonstrated that using this procedure can result in rib effective widths exceeding the rib spacing, which may be unconservative.

Tests (Dowling et al., 1977) have shown that for most practical cases, shear lag can be ignored in calculating the ultimate compressive strength of stiffened or unstiffened girder flanges (Lamas and Dowling, 1980; Burgan and Dowling, 1985; Jetteur et al., 1984; and Hindi, 1991). Thus, a flange may normally be considered to be loaded uniformly across its width. It necessary to consider the flange effectiveness in greater detail only in the case of flanges with particularly large aspect ratios ($L/B < 5$) or particularly slender edge panels or stiffeners (Burgan and Dowling, 1985 and Hindi, 1991) is it necessary to consider the flange effectiveness in greater detail.

Consideration of inelastic behavior can increase the effective width as compared to elastic analysis. At

for strength limit states for positive and negative flexure. For service and fatigue limit states in regions of high shear, the effective deck width can be determined by refined analysis or other accepted approximate methods.

ultimate loading, the region of the flange plate above the web can yield and spread the plasticity (and distribute stress) outward if the plate maintains local stability. Results from studies by Chen et al. (2005) on composite steel girders, which included several tub-girder bridges, indicate that the full slab width may be considered effective in both positive and negative moment regions.

Thus, orthotropic plates acting as flanges are considered fully effective for strength limit state evaluations from positive and negative flexure when the L/B ratio is at least 5. For the case of $L/B < 5$, only a width of one-fifth of the effective span should be considered effective. For service and fatigue limit states in regions of high shear, a special investigation into shear lag should be done.

4.6.2.6.5—*Transverse Floorbeams and Integral Bent Caps*

For transverse floorbeams and for integral bent caps designed with a composite concrete deck slab, the effective flange width overhanging each side of the transverse floorbeam or bent cap web shall not exceed six times the least slab thickness or one-tenth of the span length. For cantilevered transverse floorbeams or integral bent caps, the span length shall be taken as two times the length of the cantilever span.

C4.6.2.6.5

The provisions for the effective flange width for transverse floorbeams and integral bent caps are based on past successful practice, specified by Article 8.10.1.4 of the 2002 *AASHTO Standard Specifications*.

[*This space is intentionally left blank. —ed.*]

[This page is intentionally left blank. —ed.]

4.6.2.7—Lateral Wind Load Distribution in Multibeam Bridges

4.6.2.7.1—I-Sections

In bridges with composite decks, noncomposite decks with concrete haunches, and other decks that can provide horizontal diaphragm action, wind load on the upper half of the outside beam, the deck, vehicles, barriers, and appurtenances shall be assumed to be directly transmitted to the deck, acting as a lateral diaphragm carrying this load to supports. Wind load on the lower half of the outside beam shall be assumed to be applied laterally to the lower flange.

For bridges with decks that cannot provide horizontal diaphragm action, the lever rule shall apply for distribution of the wind load to the top and bottom flanges.

Bottom and top flanges subjected to lateral wind load shall be assumed to carry that load to adjacent brace points by flexural action. Such brace points occur at wind bracing nodes or at cross-frames and diaphragm locations.

The lateral forces applied at brace points by the flanges shall be transmitted to the supports by one of the following load paths:

- Truss action of horizontal wind bracing in the plane of the flange;
- Frame action of the cross-frames or diaphragms transmitting the forces into the deck or the wind bracing in the plane of the other flange, and then by diaphragm action of the deck, or truss action of the wind bracing, to the supports;
- Lateral bending of the flange subjected to the lateral forces and all other flanges in the same plane, transmitting the forces to the ends of the span, for example, where the deck cannot provide horizontal diaphragm action, and there is no wind bracing in the plane of either flange.

C4.6.2.7.1

Precast concrete plank decks and timber decks are not solid diaphragms and should not be assumed to provide horizontal diaphragm action unless evidence is available to show otherwise.

Unless a more refined analysis is made, the wind force, wind moment, horizontal force to be transmitted by diaphragms and cross-frames, and horizontal force to be transmitted by lateral bracing may be calculated as indicated below. This procedure is presented for beam bridges but may be adapted for other types of bridges.

The wind force, W , may be applied to the flanges of exterior members. For composite members and noncomposite members with cast-in-place concrete or orthotropic steel decks, W need not be applied to the top flange.

$$W = \frac{\eta_i \gamma P_D d}{2} \quad (\text{C4.6.2.7.1-1})$$

where:

- W = factored wind force per unit length applied to the flange (kip/ft)
- P_D = design horizontal wind pressure specified in Article 3.8.1 (ksf)
- d = depth of the member (ft)
- γ = load factor specified in Table 3.4.1-1 for the particular group loading combination
- η_i = load modifier relating to ductility, redundancy, and operational importance as specified in Article 1.3.2.1

For the first two load paths, the maximum wind moment on the loaded flange may be determined as:

$$M_w = \frac{WL_b^2}{10} \quad (\text{C4.6.2.7.1-2})$$

where:

- M_w = maximum lateral moment in the flange due to the factored wind loading (kip-ft)
- W = factored wind force per unit length applied to the flange (kip/ft)
- L_b = spacing of brace points (ft)

For the third load path, the maximum wind moment on the loaded flange may be computed as:

$$M_w = \frac{WL_b^2}{10} + \frac{WL^2}{8N_b} \quad (\text{C4.6.2.7.1-3})$$

where:

- M_w = total lateral moment in the flange due to the factored wind loading (kip-ft)

- W = factored wind force per unit length applied to the flange (kip/ft)
 L_b = spacing of cross-frames or diaphragms (ft)
 N_b = number of longitudinal members
 L = span length (ft)

Eq. C4.6.2.7.1-3 is based on the assumption that cross-frames and diaphragms act as struts in distributing the wind force on the exterior flange to adjacent flanges. If there are no cross-frames or diaphragms, the first term should be taken as 0.0, and N_b should be taken as 1.0.

The horizontal wind force applied to each brace point may be calculated as:

$$P_w = WL_b \quad (\text{C4.6.2.7.1-4})$$

where:

- P_w = lateral wind force applied to the brace point (kips)
 W = wind force per unit length from Eq. C4.6.2.7.1-1 (kip/ft)
 L_b = spacing of diaphragms or cross-frames (ft)

Lateral bracing systems required to support both flanges due to transfer of wind loading through diaphragms or cross-frames shall be designed for a horizontal force of $2P_w$ at each brace point.

4.6.2.7.2—Box Sections

One quarter of the wind force on a box section shall be applied to the bottom flange of the exterior box beam. The section assumed to resist the wind force shall consist of the bottom flange and a part of the web as determined in Sections 5 and 6. The other three quarters of the wind force on a box section, plus the wind force on vehicles, barriers, and appurtenances, shall be assumed to be transmitted to the supports by diaphragm action of the deck.

Interbox lateral bracing shall be provided if the section assumed to resist the wind force is not adequate.

4.6.2.7.3—Construction

The need for temporary wind bracing during construction shall be investigated for I- and box-section bridges.

4.6.2.8—Seismic Lateral Load Distribution

4.6.2.8.1—Applicability

These provisions shall apply to diaphragms, cross-frames, and lateral bracing, which are part of the seismic lateral force resisting system in common slab-on-girder bridges in Seismic Zones 2, 3, and 4. The provisions of Article 3.10.9.2 shall apply to Seismic Zone 1.

4.6.2.8.2—Design Criteria

The Engineer shall demonstrate that a clear, straightforward load path to the substructure exists and that all components and connections are capable of resisting the imposed load effects consistent with the chosen load path.

The flow of forces in the assumed load path must be accommodated through all affected components and details including, but not limited to, flanges and webs of main beams or girders, cross-frames, connections, slab-to-girder interfaces, and all components of the bearing assembly from top flange interface through the confinement of anchor bolts or similar devices in the substructure.

The analysis and design of end diaphragms and cross-frames shall consider horizontal supports at an appropriate number of bearings. Slenderness and connection requirements of bracing members that are part of the lateral force resisting system shall comply with applicable provisions specified for main member design.

Members of diaphragms and cross-frames identified by the Designer as part of the load path carrying seismic forces from the superstructure to the bearings shall be designed and detailed to remain elastic, based on the applicable gross area criteria, under all design earthquakes, regardless of the type of bearings used. The applicable provisions for the design of main members shall apply.

4.6.2.8.3—Load Distribution

A viable load path shall be established to transmit lateral loads to the foundation based on the stiffness characteristics of the deck, diaphragms, cross-frames, and lateral bracing. Unless a more refined analysis is made, an approximate load path shall be assumed as noted below.

- In bridges with:
 - A concrete deck that can provide horizontal diaphragm action, or
 - A horizontal bracing system in the plane of the top flange,

the lateral loads applied to the deck shall be assumed to be transmitted directly to the bearings through end diaphragms or cross-frames. The development and analysis of the load path through the deck or through the top lateral bracing, if present, shall utilize assumed structural actions analogous to those used for the analysis of wind loadings.

C4.6.2.8.2

Diaphragms, cross-frames, lateral bracing, bearings, and substructure elements are part of a seismic load resisting system in which the lateral loads and performance of each element are affected by the strength and stiffness characteristics of the other elements. Past earthquakes have shown that when one of these elements responded in a ductile manner or allowed some movement, damage was limited. In the strategy taken herein, it is assumed that ductile plastic hinging in substructure is the primary source of energy dissipation. Alternative design strategies may be considered if approved by the Owner.

C4.6.2.8.3

A continuous path is necessary for the transmission of the superstructure inertia forces to the foundation. Concrete decks have significant rigidity in their horizontal plane, and in short to medium slab-on-girder spans, their response approaches a rigid body motion. Therefore, the lateral loading of the intermediate diaphragms and cross-frames is minimal.

Bearings do not usually resist load simultaneously, and damage to only some of the bearings at one end of a span is not uncommon. When this occurs, high load concentrations can result at the location of the other bearings, which should be taken into account in the design of the end cross-frames or diaphragms. Also, a significant change in the load distribution among end cross-frame members may occur. Although studies of cyclic load behavior of bracing systems have shown that with adequate details, bracing systems can allow for ductile behavior, these design provisions require elastic behavior in end diaphragms (Astaneh-Asl and Goel, 1984; Astaneh-Asl et al., 1985; Haroun and Sheperd, 1986; Goel and El-Tayem, 1986).

- In bridges that have:
 - Decks that cannot provide horizontal diaphragm action and
 - No lateral bracing in the plane of the top flange,

the lateral loads applied to the deck shall be distributed through the intermediate diaphragms and cross-frames to the bottom lateral bracing or the bottom flange, and then to the bearings, and through the end diaphragms and cross-frames, in proportion to their relative rigidity and the respective tributary mass of the deck.

- If a bottom lateral bracing system is not present, and the bottom flange is not adequate to carry the imposed force effects, the first procedure shall be used, and the deck shall be designed and detailed to provide the necessary horizontal diaphragm action.

4.6.2.9—Analysis of Segmental Concrete Bridges

4.6.2.9.1—General

Elastic analysis and beam theory may be used to determine design moments, shears, and deflections. The effects of creep, shrinkage, and temperature differentials shall be considered as well as the effects of shear lag. Shear lag shall be considered in accordance with the provisions of Article 4.6.2.9.3.

For spans in excess of 250 ft, results of elastic analyses should be evaluated with consideration of possible variations in the modulus of elasticity of the concrete, variations in the concrete creep and shrinkage properties, and the impact of variations in the construction schedule on these and other design parameters.

4.6.2.9.2—Strut-and-Tie Models

Strut-and-tie models may be used for analysis in areas of load or geometrical discontinuity.

4.6.2.9.3—Effective Flange Width

Effective flange width for service load stress calculations may be determined by the provisions of Article 4.6.2.6.2.

The section properties for normal forces may be based on Figure 4.6.2.6.2-4 or determined by more rigorous analysis.

Bending, shear, and normal forces may be evaluated by using the corresponding factored resistances.

The capacity of a cross-section at the strength limit state may be determined by considering the full compression flange width effect.

Because the end diaphragm is required to remain elastic as part of the identified load path, stressing of intermediate cross-frames need not be considered.

C4.6.2.9.1

Analysis of concrete segmental bridges requires consideration of variation of design parameters with time as well as a specific construction schedule and method of erection. This, in turn, requires the use of a computer program developed to trace the time-dependent response of segmentally erected, prestressed concrete bridges through construction and under service loads. Among the many programs developed for this purpose, several are in the public domain and may be purchased for a nominal amount, e.g., (Ketchum, 1986; Shushkewich, 1986; Danon and Gamble, 1977).

C4.6.2.9.2

See references for background on transverse analysis of concrete box girder bridges.

4.6.2.9.4—Transverse Analysis

The transverse design of box girder segments for flexure shall consider the segment as a rigid box frame. Flanges shall be analyzed as variable depth sections, considering the fillets between the flanges and webs. Wheel loads shall be positioned to provide maximum moments, and elastic analysis shall be used to determine the effective longitudinal distribution of wheel loads for each load location. Consideration shall be given to the increase in web shear and other effects on the cross-section resulting from eccentric loading or unsymmetrical structure geometry.

The provisions of Articles 4.6.2.1 and 4.6.3.2, influence surfaces such as those by Homberg (1968) and Pucher (1964), or other elastic analysis procedures may be used to evaluate live load plus impact moment effects in the top flange of the box section.

Transverse elastic and creep shortening due to prestressing and shrinkage shall be considered in the transverse analysis.

The effect of secondary moments due to prestressing shall be included in stress calculations at the service limit state and construction evaluation. At the strength limit state, the secondary force effects induced by prestressing, with a load factor of 1.0, shall be added algebraically to the force effects due to factored dead and live loads and other applicable loads.

4.6.2.9.5—Longitudinal Analysis

4.6.2.9.5a—General

Longitudinal analysis of segmental concrete bridges shall consider a specific construction method and construction schedule as well as the time-related effects of concrete creep, shrinkage, and prestress losses.

The effect of secondary moments due to prestressing shall be included in stress calculations at the service limit state. At the strength limit state, the secondary force effects induced by prestressing, with a load factor of 1.0, shall be added algebraically to other applicable factored loads.

4.6.2.9.5b—Erection Analysis

Analysis of the structure during any construction stage shall consider the construction load combinations, stresses, and stability considerations specified in Article 5.14.2.3.

4.6.2.9.5c—Analysis of the Final Structural System

The provisions of Article 5.14.2.2.3 shall apply.

4.6.2.10—Equivalent Strip Widths for Box Culverts

4.6.2.10.1—General

This Article shall be applied to box culverts with depths of fill less than 2.0 ft.

4.6.2.10.2—Case 1: Traffic Travels Parallel to Span

When traffic travels primarily parallel to the span, culverts shall be analyzed for a single loaded lane with the single lane multiple presence factor.

The axle load shall be distributed to the top slab for determining moment, thrust, and shear as follows:

Perpendicular to the span:

$$E = 96 + 1.44S \quad (4.6.2.10.2-1)$$

Parallel to the span:

$$E_{span} = L_T + LLDF(H) \quad (4.6.2.10.2-2)$$

where:

- E = equivalent distribution width perpendicular to span (in.)
- S = clear span (ft)
- E_{span} = equivalent distribution length parallel to span (in.)
- L_T = length of tire contact area parallel to span, as specified in Article 3.6.1.2.5 (in.)
- $LLDF$ = factor for distribution of live load with depth of fill, 1.15 or 1.00, as specified in Article 3.6.1.2.6
- H = depth of fill from top of culvert to top of pavement (in.)

4.6.2.10.3—Case 2: Traffic Travels Perpendicular to Span

When traffic travels perpendicular to the span, live load shall be distributed to the top slab using the equations specified in Article 4.6.2.1 for concrete decks with primary strips perpendicular to the direction of traffic.

C4.6.2.10.1

Design for depths of fill of 2.0 ft or greater are covered in Article 3.6.1.2.6.

C4.6.2.10.2

Culverts are designed under the provisions of Section 12. Box culverts are normally analyzed as two-dimensional frames. Equivalent strip widths are used to simplify the analysis of the three-dimensional response to live loads. Eqs. 4.6.2.10.2-1 and 4.6.2.10.2-2 are based on research (McGrath et al., 2004) that investigated the forces in box culverts with spans up to 24.0 ft.

The distribution widths are based on distribution of shear forces. Distribution widths for positive and negative moments are wider; however, using the narrower width in combination with a single lane multiple presence factor provides designs adequate for multiple loaded lanes for all force effects.

Although past practice has been to ignore the distribution of live load with depth of fill, consideration of this effect, as presented in Eq. 4.6.2.10.2-2, produces a more accurate model of the changes in design forces with increasing depth of fill. The increased load length parallel to the span, as allowed by Eq. 4.6.2.10.2-2, may be conservatively neglected in design.

C4.6.2.10.3

Culverts with traffic traveling perpendicular to the span can have two or more trucks on the same design strip at the same time. This must be considered, with the appropriate multiple presence factor, in analysis of the culvert structural response.

4.6.2.10.4—Precast Box Culverts

For precast box culverts with top slabs having span-to-thickness ratios (s/t) of 18 or less and segment lengths greater than or equal to 4 ft in length, shear transfer across the joint need not be provided.

For precast box culverts not satisfying the requirements noted above, the design shall incorporate one of the following:

- Provide the culvert with a means of shear transfer between the adjacent sections. Shear transfer may be provided by pavement, soil fill, or a physical connection between adjacent sections.
- Design the section ends as edge beams in accordance with the provisions of Article 4.6.2.1.4b using the distribution width computed from Eq. 4.6.2.10.2-1. The distribution width shall not exceed the length between two adjacent joints.

C4.6.2.10.4

Precast box culverts manufactured in accordance with AASHTO M 273 are often installed with joints that do not provide a means of direct shear transfer across the joints of adjacent sections under service load conditions. This practice is based on research (James, 1984; Frederick, et al., 1988) which indicated significant shear transfer may not be necessary under service loading. The response of the sections tested was typified by small deflections and strains indicating that cracking did not occur under service wheel loads with no earth cover and that the demand on the section was lower than predicted by the design, which was based conservatively on a cracked section. While there are no known service issues with installation of standard box sections without means of shear transfer across joints, analysis (McGrath et al., 2004) shows that stresses are substantially higher when a box culvert is subjected to a live load at a free edge than when loaded away from a free edge.

However, research performed on precast box culverts that were loaded at the edge of the section (Abolmaali and Garg, 2007) has shown that no means of load transfer across the joint is required when the live load is distributed per Articles 4.6.2.10.2 and 4.6.2.10.3 and the top slab of the box culvert is designed in accordance with Article 5.8.3. The tested boxes were shown to have significantly more shear strength than predicted by Article 5.8.3.

For box culverts outside of the normal ASTM/AASHTO dimensional requirements, some fill or pavement will likely provide sufficient shear transfer to distribute live load to adjacent box sections without shear keys to avoid higher stresses due to edge loading. Otherwise, for box culverts outside of ASTM/AASHTO dimensional requirements with zero depth of cover, and no pavement, soil, or other means of shear transfer such as shear keys, designers should design the culvert section for the specified reduced distribution widths lacking a more rigorous design method.

4.6.3—Refined Methods of Analysis

4.6.3.1—General

Refined methods, listed in Article 4.4, may be used for the analysis of bridges. In such analyses, consideration shall be given to aspect ratios of elements, positioning and number of nodes, and other features of topology that may affect the accuracy of the analytical solution.

C4.6.3.1

The number of possible locations for positioning the design vehicular live load will be large when determining the extreme force effect in an element using a refined method of analysis. The following are variable:

- The location of the design lanes when the available deck width contains a fraction of a design lane width,
- Which of the design lanes are actually used,

A structurally continuous railing, barrier, or median, acting compositely with the supporting components, may be considered to be structurally active at service and fatigue limit states.

When a refined method of analysis is used, a table of live load distribution coefficients for extreme force effects in each span shall be provided in the contract documents to aid in permit issuance and rating of the bridge.

4.6.3.2—Decks

4.6.3.2.1—General

Unless otherwise specified, flexural and torsional deformation of the deck shall be considered in the analysis but vertical shear deformation may be neglected.

Locations of flexural discontinuity through which shear may be transmitted should be modeled as hinges.

In the analysis of decks that may crack and/or separate along element boundaries when loaded, Poisson's ratio may be neglected. The wheel loads shall be modeled as patch loads distributed over an area, as specified in Article 3.6.1.2.5, taken at the contact surface. This area may be extended by the thickness of the wearing surface, integral or nonintegral, on all four sides. When such extension is utilized, the thickness of the wearing surface shall be reduced for any possible wear at the time of interest. Other extended patch areas may be utilized with the permission of the Owner provided that such extended area is consistent with the assumptions in, and application of, a particular refined method of analysis.

4.6.3.2.2—Isotropic Plate Model

For the purpose of this section, bridge decks that are solid, have uniform or close to uniform depth, and whose stiffness is close to equal in every in-plane direction shall be considered isotropic.

- The longitudinal location of the design vehicular live load in each lane,
- The longitudinal axle spacing of the design vehicular live load,
- The transverse location of the design vehicular live load in each lane.

This provision reflects the experimentally observed response of bridges. This source of stiffness has traditionally been neglected but exists and may be included, provided that full composite behavior is assured.

These live load distribution coefficients should be provided for each combination of component and lane.

C4.6.3.2.1

In many solid decks, the wheel load-carrying contribution of torsion is comparable to that of flexure. Large torsional moments exist in the end zones of skewed girder bridges due to differential deflection. In most deck types, shear stresses are rather low, and their contribution to vertical deflection is not significant. In-plane shear deformations, which gave rise to the concept of effective width for composite bridge decks, should not be neglected.

C4.6.3.2.2

Analysis is rather insensitive to small deviations in constant depth, such as those due to superelevation, crown, and haunches. In slightly cracked concrete slabs, even a large difference in the reinforcement ratio will not cause significant changes in load distribution.

The torsional stiffness of the deck may be estimated using Eq. C4.6.2.2.1-1 with b equal to 1.0.

4.6.3.2.3—Orthotropic Plate Model

In orthotropic plate modeling, the flexural rigidity of the elements may be uniformly distributed along the cross-section of the deck. Where the torsional stiffness of the deck is not contributed solely by a solid plate of uniform thickness, the torsional rigidity should be established by physical testing, three-dimensional analysis, or generally accepted and verified approximations.

4.6.3.2.4—Refined Orthotropic Deck Model

Refined analysis of orthotropic deck structures subjected to direct wheel loads should be accomplished using a detailed three-dimensional shell or solid finite element structural model. The structural model should include all components and connections and consider local structural stress at fatigue prone details as shown in Table 6.6.1.2.3-1. Structural modeling techniques that utilize the following simplifying assumptions may be applied:

- Linear elastic material behavior,
- Small deflection theory,
- Plane sections remain plane,
- Neglect residual stresses, and
- Neglect imperfections and weld geometry.

Meshing shall be sufficiently detailed to calculate local stresses at weld toes and to resolve the wheel patch pressure loading with reasonable accuracy.

4.6.3.3—Beam-Slab Bridges*4.6.3.3.1—General*

The aspect ratio of finite elements and grid panels should not exceed 5.0. Abrupt changes in size and/or shape of finite elements and grid panels should be avoided.

Nodal loads shall be statically equivalent to the actual loads being applied.

C4.6.3.2.3

The accuracy of the orthotropic plate analysis is sharply reduced for systems consisting of a small number of elements subjected to concentrated loads.

C4.6.3.2.4

Further guidance on evaluating local structural stresses using finite element modeling is provided in *Manual for Design, Construction, and Maintenance of Orthotropic Steel Bridges* (FHWA, 2012).

C4.6.3.3.1

More restrictive limits for aspect ratio may be specified for the software used.

In the absence of other information, the following guidelines may be used at the discretion of the Engineer:

- A minimum of five, and preferably nine, nodes per beam span should be used.
- For finite element analyses involving plate and beam elements, it is preferable to maintain the relative vertical distances between various elements. If this is not possible, longitudinal and transverse elements may be positioned at the midthickness of the plate-bending elements, provided that the eccentricities are included in the equivalent properties of those sections that are composite.

- For grid analysis or finite element and finite difference analyses of live load, the slab shall be assumed to be effective for stiffness in both positive and negative flexure. In a filled or partially filled grid system, composite section properties should be used.
- In finite element analysis, an element should have membrane capability with discretization sufficient to properly account for shear lag. The force effects so computed should be applied to the appropriate composite or noncomposite section for computing resistance.
- For longitudinal composite members in grid analyses, stiffness should be computed by assuming a width of the slab to be effective, but it need not be less than that specified in Article 4.6.2.6.
- For K-frame and X-frame diaphragms, equivalent beam flexure and shear stiffnesses should be computed. For bridges with widely spaced diaphragms, it may be desirable to use notional transverse beam members to model the deck. The number of such beams is to some extent discretionary. The significance of shear lag in the transverse beam-slab width as it relates to lateral load distribution can be evaluated qualitatively by varying the stiffness of the beam-slab elements within reasonable limits and observing the results. Such a sensitivity study often shows that this effect is not significant.
- Live load force effects in diaphragms should be calculated by the grid or finite element analysis. The easiest way to establish extreme force effects is by using influence surfaces analogous to those developed for the main longitudinal members.
- The St. Venant torsional inertia may be determined using the equation in Article C4.6.2.2.1. Transformation of concrete and steel to a common material should be on the basis of shear modulus, G , which can be taken as $G = 0.5E/(1+\mu)$. It is recommended that the St. Venant rigidity of composite sections utilize only one-half of the effective width of the flexural section, as described above, before transformation.

4.6.3.3.2—Curved Steel Bridges

Refined analysis methods should be used for the analysis of curved steel bridges unless the Engineer ascertains that approximate analysis methods are appropriate according to the provisions of Article 4.6.2.2.4.

C4.6.3.3.2

Refined analysis methods, identified in Article 4.4, are generally computer-based. The finite strip and finite element methods have been the most common. The finite strip method is less rigorous than the finite element method and has fallen into disuse with the advent of more powerful computers. Finite element programs may provide grid analyses using a series of

beam elements connected in a plane. Refinements of the grid model may include offset elements. Frequently, the torsional warping degree of freedom is not available in beam elements. The finite element method may be applied to a three-dimensional model of the superstructure. A variety of elements may be used in this type of model. The three-dimensional model may be made capable of recognizing warping torsion by modeling each girder cross-section with a series of elements.

The stiffness of supports, including lateral restraint such as integral abutments or integral piers, should be recognized in the analysis. Since bearing restraint is offset from the neutral axis of the girders, large lateral forces at the bearings often occur and may create significant bending in the girders, which may lead to lower girder moments than would be computed if the restraints were not present. The Engineer should ascertain that any such benefit recognized in the design will be present throughout the useful life of the bridge.

Loads may be applied directly to the structural model, or applied to influence lines or influence surfaces. Only where small-deflection elastic solutions are used are influence surfaces or influence lines appropriate. The Engineer should ascertain that dead loads are applied as accurately as possible.

4.6.3.4—Cellular and Box Bridges

A refined analysis of cellular bridges may be made by any of the analytic methods specified in Article 4.4, except the yield line method, which accounts for the two dimensions seen in plan view and for the modeling of boundary conditions. Models intended to quantify torsional warping and/or transverse frame action should be fully three-dimensional.

For single box cross-sections, the superstructure may be analyzed as a spine beam for both flexural and torsional effects. A steel box should not be considered to be torsionally rigid unless internal bracing is provided to maintain the box cross-section. The transverse position of bearings shall be modeled.

4.6.3.5—Truss Bridges

A refined plane frame or space frame analysis shall include consideration for the following:

- Composite action with the deck or deck system;
- Continuity among the components;
- Force effects due to self-weight of components, change in geometry due to deformation, and axial offset at panel points; and
- In-plane and out-of-plane buckling of components including original out-of-straightness, continuity among the components and the effect axial forces present in those components.

C4.6.3.5

Load applied to deck or floorbeams instead of to truss joints will yield results that more completely quantify out-of-plane actions.

Experience has shown that dead load force effects calculated using either plane frame or space frame analysis in a truss with properly cambered primary and secondary members and detailed to minimize eccentricity at joints, will be quite close to those calculated by the conventional approximations. In many cases, a complete three-dimensional frame analysis may be the only way to accurately calculate forces in secondary members, particularly live load force effects.

Out-of-plane buckling of the upper chords of pony truss bridges shall be investigated. If the truss derives its lateral stability from transverse frames, of which the floorbeams are a part, the deformation of the floorbeams due to vehicular loading shall be considered.

4.6.3.6—Arch Bridges

The provisions of Article 4.6.3.5 shall apply where applicable.

The effect of the extension of cable hangers shall be considered in the analysis of an arch tie.

Where not controlled through proper detailing, rib shortening should be investigated.

The use of large deflection analysis of arches of longer spans should be considered in lieu of the moment magnification correction as specified in Article 4.5.3.2.c.

When the distribution of stresses between the top and bottom chords of trussed arches is dependent on the manner of erection, the manner of erection shall be indicated in the contract documents.

4.6.3.7—Cable-Stayed Bridges

The distribution of force effects to the components of a cable-stayed bridge may be determined by either spatial or planar structural analysis if justified by consideration of tower geometry, number of planes of stays, and the torsional stiffness of the deck superstructure.

Cable-stayed bridges shall be investigated for nonlinear effects that may result from:

- The change in cable sag at all limit states,
- Deformation of deck superstructure and towers at all limit states, and
- Material nonlinearity at the extreme event limit states.

Cable sag may be investigated using an equivalent member modeled as a chord with modified modulus of elasticity given by Eq. 4.6.3.7-1 for instantaneous stiffness and Eq. 4.6.3.7-2, applied iteratively, for changing cable loads.

$$E_{MOD} = E \left[1 + \frac{EAW^2(\cos \alpha)^5}{12H^3} \right]^{-1} \quad (4.6.3.7-1)$$

C4.6.3.6

Rib shortening and arch design and construction are discussed by Nettleton (1977).

Any single-step correction factor cannot be expected to accurately model deflection effects over a wide range of stiffnesses.

If a hinge is provided at the crown of the rib in addition to hinges at the abutment, the arch becomes statically determinate, and stresses due to change of temperature and rib shortening are essentially eliminated.

Arches may be analyzed, designed, and constructed as hinged under dead load or portions of dead load and as fixed at some hinged locations for the remaining design loads.

In trussed arches, considerable latitude is available in design for distribution of stresses between the top and bottom chords dependent on the manner of erection. In such cases, the manner of erection should be indicated in the contract documents.

C4.6.3.7

Nonlinear effects on cable-stayed bridges are treated in several texts, e.g., (Podolny and Scalzi, 1986; Troitsky, 1977), and a report by the ASCE Committee on Cable Suspended Bridges (ASCE, 1991), from which the particular forms of Eqs. 4.6.3.7-1 and 4.6.3.7-2 were taken.

$$E_{MOD} = E \left[1 + \frac{(H_1 + H_2) EAW^2 (\cos \alpha)^5}{24H_1^2 H_2^2} \right]^{-1} \quad (4.6.3.7-2)$$

where:

- E = modulus of elasticity of the cable (ksi)
- W = total weight of cable (kip)
- A = cross-sectional area of cable (in.²)
- α = angle between cable and horizontal (degrees)
- $H, H_1,$
 H_2 = horizontal component of cable force (kip)

The change in force effects due to deflection may be investigated using any method that satisfies the provisions of Article 4.5.3.2.1 and accounts for the change in orientation of the ends of cable stays.

Cable-stayed bridges shall be investigated for the loss of any one cable stay.

4.6.3.8—Suspension Bridges

Force effects in suspension bridges shall be analyzed by the large deflection theory for vertical loads. The effects of wind loads shall be analyzed, with consideration of the tension stiffening of the cables. The torsional rigidity of the deck may be neglected in assigning forces to cables, suspenders, and components of stiffening trusses.

C4.6.3.8

In the past, short suspension bridges have been analyzed by conventional small deflection theories. Correction factor methods have been used on short- to moderate-span bridges to account for the effect of deflection, which is especially significant for calculating deck system moments. Any contemporary suspension bridge would have a span such that the large deflection theory should be used. Suitable computer programs are commercially available. Therefore, there is little rationale to use anything other than the large deflection solution.

For the same economic reasons, the span would probably be long enough that the influence of the torsional rigidity of the deck, combined with the relatively small effect of live load compared to dead load, will make the simple sum-of-moments technique suitable to assign loads to the cables and suspenders and usually even to the deck system, e.g., a stiffening truss.

4.6.4—Redistribution of Negative Moments in Continuous Beam Bridges

4.6.4.1—General

The Owner may permit the redistribution of force effects in multispans, multibeam, or girder superstructures. Inelastic behavior shall be restricted to the flexure of beams or girders, and inelastic behavior due to shear and/or uncontrolled buckling shall not be permitted. Redistribution of loads shall not be considered in the transverse direction.

The reduction of negative moments over the internal supports due to the redistribution shall be accompanied by a commensurate increase in the positive moments in the spans.

4.6.4.2—Refined Method

The negative moments over the support, as established by linear elastic analysis, may be decreased by a redistribution process considering the moment-rotation characteristics of the cross-section or by a recognized mechanism method. The moment-rotation relationship shall be established using material characteristics, as specified herein, and/or verified by physical testing.

4.6.4.3—Approximate Procedure

In lieu of the analysis described in Article 4.6.4.2, simplified redistribution procedures for concrete and steel beams, as specified in Sections 5 and 6, respectively, may be used.

4.6.5—Stability

The investigation of stability shall utilize the large deflection theory.

4.6.6—Analysis for Temperature Gradient

Where determination of force effects due to vertical temperature gradient is required, the analysis should consider axial extension, flexural deformation, and internal stresses.

Gradients shall be as specified in Article 3.12.3.

C4.6.6

The response of a structure to a temperature gradient can be divided into three effects as follows:

- **AXIAL EXPANSION**—This is due to the uniform component of the temperature distribution that should be considered simultaneously with the uniform temperature specified in Article 3.12.2. It may be calculated as:

$$T_{UG} = \frac{1}{A_c} \iint T_G \, dw \, dz \quad (\text{C4.6.6-1})$$

The corresponding uniform axial strain is:

$$\epsilon_u = \alpha(T_{UG} + T_u) \quad (\text{C4.6.6-2})$$

- **FLEXURAL DEFORMATION**—Because plane sections remain plane, a curvature is imposed on the superstructure to accommodate the linearly variable component of the temperature gradient. The rotation per unit length corresponding to this curvature may be determined as:

$$\phi = \frac{\alpha}{I_c} \iint T_G z \, dw \, dz = \frac{1}{R} \quad (\text{C4.6.6-3})$$

If the structure is externally unrestrained, i.e., simply supported or cantilevered, no external force effects are developed due to this superimposed deformation.

The axial strain and curvature may be used in both flexibility and stiffness formulations. In the former, ε_u may be used in place of P/AE , and ϕ may be used in place of M/EI in traditional displacement calculations. In the latter, the fixed-end force effects for a prismatic frame element may be determined as:

$$N = EA_c \varepsilon_u \quad (\text{C4.6.6-4})$$

$$M = EI_c \phi \quad (\text{C4.6.6-5})$$

An expanded discussion with examples may be found in Ghali and Neville (1989).

Strains induced by other effects, such as shrinkage and creep, may be treated in a similar manner.

- **INTERNAL STRESS**—Using the sign convention that compression is positive, internal stresses in addition to those corresponding to the restrained axial expansion and/or rotation may be calculated as:

$$\sigma_E = E[\alpha T_G - \alpha T_{UG} - \phi z] \quad (\text{C4.6.6-6})$$

where:

- T_G = temperature gradient ($\Delta^\circ\text{F}$)
- T_{UG} = temperature averaged across the cross-section ($^\circ\text{F}$)
- T_u = uniform specified temperature ($^\circ\text{F}$)
- A_c = cross-section area—transformed for steel beams (in.^2)
- I_c = inertia of cross-section—transformed for steel beams (in.^4)
- α = coefficient of thermal expansion ($\text{in./in./}^\circ\text{F}$)
- E = modulus of elasticity (ksi)
- R = radius of curvature (ft)
- w = width of element in cross-section (in.)
- z = vertical distance from center of gravity of cross-section (in.)

For example, the flexural deformation part of the gradient flexes a prismatic superstructure into a segment of a circle in the vertical plane. For a two-span structure with span length, L , in ft, the unrestrained beam would lift off from the central support by $\Delta = 6 L^2/R$ in. Forcing the beam down to eliminate Δ would develop a moment whose value at the pier would be:

$$M_c = \frac{3}{2} EI_c \phi \quad (\text{C4.6.6-7})$$

Therefore, the moment is a function of the beam rigidity and imposed flexure. As rigidity approaches 0.0 at the strength limit state, M_c tends to disappear. This behavior also indicates the need for ductility to ensure structural integrity as rigidity decreases.

4.7—DYNAMIC ANALYSIS

4.7.1—Basic Requirements of Structural Dynamics

4.7.1.1—General

For analysis of the dynamic behavior of bridges, the stiffness, mass, and damping characteristics of the structural components shall be modeled.

The minimum number of degrees-of-freedom included in the analysis shall be based upon the number of natural frequencies to be obtained and the reliability of the assumed mode shapes. The model shall be compatible with the accuracy of the solution method. Dynamic models shall include relevant aspects of the structure and the excitation. The relevant aspects of the structure may include the:

- Distribution of mass,
- Distribution of stiffness, and
- Damping characteristics.

The relevant aspects of excitation may include the:

- Frequency of the forcing function,
- Duration of application, and
- Direction of application.

4.7.1.2—Distribution of Masses

The modeling of mass shall be made with consideration of the degree of discretization in the model and the anticipated motions.

C4.7.1.1

Typically, analysis for vehicle- and wind-induced vibrations is not to be considered in bridge design. Although a vehicle crossing a bridge is not a static situation, the bridge is analyzed by statically placing the vehicle at various locations along the bridge and applying a dynamic load allowance, as specified in Article 3.6.2, to account for the dynamic responses caused by the moving vehicle. However, in flexible bridges and long slender components of bridges that may be excited by bridge movement, dynamic force effects may exceed the allowance for impact given in Article 3.6.2. In most observed bridge vibration problems, the natural structural damping has been very low. Flexible continuous bridges may be especially susceptible to vibrations. These cases may require analysis for moving live load.

If the number of degrees-of-freedom in the model exceeds the number of dynamic degrees-of-freedom used, a standard condensation procedure may be employed.

Condensation procedures may be used to reduce the number of degrees-of-freedom prior to the dynamic analysis. Accuracy of the higher modes can be compromised with condensation. Thus if higher modes are required, such procedures should be used with caution.

The number of frequencies and mode shapes necessary to complete a dynamic analysis should be estimated in advance or determined as an early step in a multistep approach. Having determined that number, the model should be developed to have a larger number of applicable degrees-of-freedom.

Sufficient degrees-of-freedom should be included to represent the mode shapes relevant to the response sought. One rule-of-thumb is that there should be twice as many degrees-of-freedom as required frequencies.

The number of degrees-of-freedom and the associated masses should be selected in a manner that approximates the actual distributive nature of mass. The number of required frequencies also depends on the frequency content of the forcing function.

C4.7.1.2

The distribution of stiffness and mass should be modeled in a dynamic analysis. The discretization of the model should account for geometric and material variation in stiffness and mass.

The selection of the consistent or lump mass formulation is a function of the system and the response sought and is difficult to generalize. For distributive mass systems modeled with polynomial shape functions in which the mass is associated with distributive

stiffness, such as a beam, a consistent mass formulation is recommended (Paz, 1985). In lieu of a consistent formulation, lumped masses may be associated at the translational degrees-of-freedom, a manner that approximates the distributive nature of the mass (Clough and Penzian, 1975).

For systems with distributive mass associated with larger stiffness, such as in-plane stiffness of a bridge deck, the mass may be properly modeled as lumped. The rotational inertia effects should be included where significant.

4.7.1.3—Stiffness

The bridge shall be modeled to be consistent with the degrees-of-freedom chosen to represent the natural modes and frequencies of vibration. The stiffness of the elements of the model shall be defined to be consistent with the bridge being modeled.

4.7.1.4—Damping

Equivalent viscous damping may be used to represent energy dissipation.

4.7.1.5—Natural Frequencies

For the purpose of Article 4.7.2, and unless otherwise specified by the Owner, elastic undamped natural modes and frequencies of vibration shall be used. For the purpose of Articles 4.7.4 and 4.7.5, all relevant damped modes and frequencies shall be considered.

C4.7.1.3

In seismic analysis, nonlinear effects which decrease stiffness, such as inelastic deformation and cracking, should be considered.

Reinforced concrete columns and walls in Seismic Zones 2, 3, and 4 should be analyzed using cracked section properties. For this purpose, a moment of inertia equal to one-half that of the uncracked section may be used.

C4.7.1.4

Damping may be neglected in the calculation of natural frequencies and associated nodal displacements. The effects of damping should be considered where a transient response is sought.

Suitable damping values may be obtained from field measurement of induced free vibration or by forced vibration tests. In lieu of measurements, the following values may be used for the equivalent viscous damping ratio:

- Concrete construction: two percent
- Welded and bolted steel construction: one percent
- Timber: five percent

4.7.2—Elastic Dynamic Responses

4.7.2.1—Vehicle-Induced Vibration

When an analysis for dynamic interaction between a bridge and the live load is required, the Owner shall specify and/or approve surface roughness, speed, and dynamic characteristics of the vehicles to be employed for the analysis. Impact shall be derived as a ratio of the extreme dynamic force effect to the corresponding static force effect.

In no case shall the dynamic load allowance used in design be less than 50 percent of the dynamic load allowance specified in Table 3.6.2.1-1, except that no reduction shall be allowed for deck joints.

C4.7.2.1

The limitation on the dynamic load allowance reflects the fact that deck surface roughness is a major factor in vehicle/bridge interaction and that it is difficult to estimate long-term deck deterioration effects thereof at the design stage.

The proper application of the provision for reducing the dynamic load allowance is:

$$IM_{CALC} \geq 0.5IM_{Table\ 3-6} \quad (C4.7.2.1-1)$$

not:

$$\left(1 + \frac{IM}{100}\right)_{CALC} \geq 0.5 \left(1 + \frac{IM}{100}\right) \quad (C4.7.2.1-2)$$

4.7.2.2—Wind-Induced Vibration

4.7.2.2.1—Wind Velocities

For critical or essential structures, which may be expected to be sensitive to wind effects, the location and magnitude of extreme pressure and suction values shall be established by simulated wind tunnel tests.

4.7.2.2.2—Dynamic Effects

Wind-sensitive structures shall be analyzed for dynamic effects, such as buffeting by turbulent or gusting winds, and unstable wind-structure interaction, such as galloping and flutter. Slender or torsionally flexible structures shall be analyzed for lateral buckling, excessive thrust, and divergence.

4.7.2.2.3—Design Considerations

Oscillatory deformations under wind that may lead to excessive stress levels, structural fatigue, and user inconvenience or discomfort shall be avoided. Bridge decks, cable stays, and hanger cables shall be protected against excessive vortex and wind-rain-induced oscillations. Where practical, the employment of dampers shall be considered to control excessive dynamic responses. Where dampers or shape modification are not practical, the structural system shall be changed to achieve such control.

C4.7.2.2.3

Additional information on design for wind may be found in AASHTO (1985); Scanlan (1975); Simiu and Scanlan (1978); Basu and Chi (1981a); Basu and Chi (1981b); ASCE (1961); and ASCE (1991).

4.7.3—Inelastic Dynamic Responses

4.7.3.1—General

During a major earthquake or ship collision, energy may be dissipated by one or more of the following mechanisms:

- Elastic and inelastic deformation of the object that may collide with the structure,
- Inelastic deformation of the structure and its attachments,
- Permanent displacement of the masses of the structure and its attachments, and
- Inelastic deformation of special-purpose mechanical energy dissipators.

4.7.3.2—Plastic Hinges and Yield Lines

For the purpose of analysis, energy absorbed by inelastic deformation in a structural component may be assumed to be concentrated in plastic hinges and yield lines. The location of these sections may be established by successive approximation to obtain a lower bound solution for the energy absorbed. For these sections, moment-rotation hysteresis curves may be determined by using verified analytic material models.

4.7.4—Analysis for Earthquake Loads

4.7.4.1—General

Minimum analysis requirements for seismic effects shall be as specified in Table 4.7.4.3.1-1.

For the modal methods of analysis, specified in Articles 4.7.4.3.2 and 4.7.4.3.3, the design response spectrum specified in Figure 3.10.4.1-1 and Eqs. 3.10.4.2-1, 3.10.4.2-3, and 3.10.4.2.4 shall be used.

Bridges in Seismic Zone 1 need not be analyzed for seismic loads, regardless of their operational classification and geometry. However, the minimum requirements, as specified in Articles 4.7.4.4 and 3.10.9, shall apply.

4.7.4.2—Single-Span Bridges

Seismic analysis is not required for single-span bridges, regardless of seismic zone.

Connections between the bridge superstructure and the abutments shall be designed for the minimum force requirements as specified in Article 3.10.9.

Minimum support length requirements shall be satisfied at each abutment as specified in Article 4.7.4.4.

C4.7.4.2

A single-span bridge is comprised of a superstructure unit supported by two abutments with no intermediate piers.

4.7.4.3—Multispan Bridges*4.7.4.3.1—Selection of Method**C4.7.4.3.1*

For multispan structures, the minimum analysis requirements shall be as specified in Table 4.7.4.3.1-1 in which:

*	=	no seismic analysis required
UL	=	uniform load elastic method
SM	=	single-mode elastic method
MM	=	multimode elastic method
TH	=	time history method

The selection of the method of analysis depends on seismic zone, regularity, and operational classification of the bridge.

Regularity is a function of the number of spans and the distribution of weight and stiffness. Regular bridges have less than seven spans; no abrupt or unusual changes in weight, stiffness, or geometry; and no large changes in these parameters from span to span or support-to-support, abutments excluded. A more rigorous analysis procedure may be used in lieu of the recommended minimum.

Table 4.7.4.3.1-1—Minimum Analysis Requirements for Seismic Effects

Seismic Zone	Single-Span Bridges	Multispan Bridges					
		Other Bridges		Essential Bridges		Critical Bridges	
		regular	irregular	regular	irregular	regular	irregular
1	No seismic analysis required	*	*	*	*	*	*
2		SM/UL	SM	SM/UL	MM	MM	MM
3		SM/UL	MM	MM	MM	MM	TH
4		SM/UL	MM	MM	MM	TH	TH

Except as specified below, bridges satisfying the requirements of Table 4.7.4.3.1-2 may be taken as “regular” bridges. Bridges not satisfying the requirements of Table 4.7.4.3.1-2 shall be taken as “irregular” bridges.

Table 4.7.4.3.1-2—Regular Bridge Requirements

Parameter	Value				
Number of Spans	2	3	4	5	6
Maximum subtended angle for a curved bridge	90°	90°	90°	90°	90°
Maximum span length ratio from span to span	3	2	2	1.5	1.5
Maximum bent/pier stiffness ratio from span to span, excluding abutments	—	4	4	3	2

Curved bridges comprised of multiple simple-spans shall be considered to be “irregular” if the subtended angle in plan is greater than 20 degrees. Such bridges shall be analyzed by either the multimode elastic method or the time-history method.

A curved continuous-girder bridge may be analyzed as if it were straight, provided all of the following requirements are satisfied:

- The bridge is “regular” as defined in Table 4.7.4.3.1-2, except that for a two-span bridge the maximum span length ratio from span to span must not exceed 2;

- The subtended angle in plan is not greater than 90 degrees; and
- The span lengths of the equivalent straight bridge are equal to the arc lengths of the curved bridge.

If these requirements are not satisfied, then curved continuous-girder bridges must be analyzed using the actual curved geometry.

4.7.4.3.2—Single-Mode Methods of Analysis

4.7.4.3.2a—General

Either of the two single-mode methods of analysis specified herein may be used where appropriate.

4.7.4.3.2b—Single-Mode Spectral Method

The single-mode method of spectral analysis shall be based on the fundamental mode of vibration in either the longitudinal or transverse direction. For regular bridges, the fundamental modes of vibration in the horizontal plane coincide with the longitudinal and transverse axes of the bridge structure. This mode shape may be found by applying a uniform horizontal load to the structure and calculating the corresponding deformed shape. The natural period may be calculated by equating the maximum potential and kinetic energies associated with the fundamental mode shape. The amplitude of the displaced shape may be found from the elastic seismic response coefficient, C_{sm} , specified in Article 3.10.4.2, and the corresponding spectral displacement. This amplitude shall be used to determine force effects.

C4.7.4.3.2b

The single-mode spectral analysis method described in the following steps may be used for both transverse and longitudinal earthquake motions. Examples illustrating its application are given in AASHTO (1983) and ATC (1981).

- Calculate the static displacements $v_s(x)$ due to an assumed uniform loading p_o as shown in Figure C4.7.4.3.2b-1:

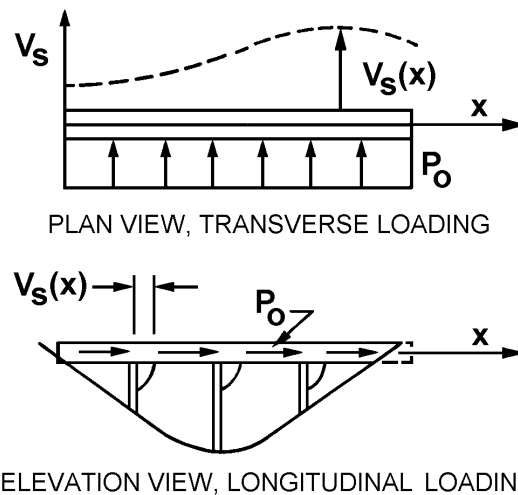

Figure C4.7.4.3.2b-1—Bridge Deck Subjected to Assumed Transverse and Longitudinal Loading

- Calculate factors α , β , and γ as:

$$\alpha = \int v_s(x) dx \tag{C4.7.4.3.2b-1}$$

$$\beta = \int w(x)v_s(x) dx \tag{C4.7.4.3.2b-2}$$

$$\gamma = \int w(x)v_s^2(x) dx \tag{C4.7.4.3.2b-3}$$

where:

- p_o = a uniform load arbitrarily set equal to 1.0 (kip/ft)
 $v_s(x)$ = deformation corresponding to p_o (ft)
 $w(x)$ = nominal, unfactored dead load of the bridge superstructure and tributary substructure (kip/ft)

The computed factors, α , β , and γ have units of (ft²), (kip-ft), and (kip-ft²), respectively.

- Calculate the period of the bridge as:

$$T_m = 2\pi \sqrt{\frac{\gamma}{p_o g \alpha}} \quad (\text{C4.7.4.3.2b-4})$$

where:

g = acceleration of gravity (ft/sec.²)

- Using T_m and Eqs. 3.10.4.2-1, 3.10.4.2-4, or 3.10.4.2-5, calculate C_{sm} .
- Calculate the equivalent static earthquake loading $p_e(x)$ as:

$$p_e(x) = \frac{\beta C_{sm}}{\gamma} w(x) v_s(x) \quad (\text{C4.7.4.3.2b-5})$$

where:

C_{sm} = the dimensionless elastic seismic response coefficient given by Eqs. 3.10.4.2-1, 3.10.4.2-4, or 3.10.4.2-5

$p_e(x)$ = the intensity of the equivalent static seismic loading applied to represent the primary mode of vibration (kip/ft)

- Apply loading $p_e(x)$ to the structure, and determine the resulting member force effects.

4.7.4.3.2c—Uniform Load Method

The uniform load method shall be based on the fundamental mode of vibration in either the longitudinal or transverse direction of the base structure. The period of this mode of vibration shall be taken as that of an equivalent single mass-spring oscillator. The stiffness of this equivalent spring shall be calculated using the maximum displacement that occurs when an arbitrary uniform lateral load is applied to the bridge. The elastic seismic response coefficient, C_{sm} , specified in Article 3.10.4.2 shall be used to calculate the equivalent uniform seismic load from which seismic force effects are found.

C4.7.4.3.2c

The uniform load method, described in the following steps, may be used for both transverse and longitudinal earthquake motions. It is essentially an equivalent static method of analysis that uses a uniform lateral load to approximate the effect of seismic loads. The method is suitable for regular bridges that respond principally in their fundamental mode of vibration. Whereas all displacements and most member forces are calculated with good accuracy, the method is known to overestimate the transverse shears at the abutments by up to 100 percent. If such conservatism is undesirable, then the single-mode spectral analysis method specified in Article 4.7.4.3.2b is recommended.

- Calculate the static displacements $v_s(x)$ due to an assumed uniform load p_o , as shown in Figure C4.7.4.3.2b-1. The uniform loading p_o is applied over the length of the bridge; it has units of force per unit length and may be arbitrarily set equal to 1.0. The static displacement $v_s(x)$ has units of length.
- Calculate the bridge lateral stiffness, K , and total weight, W , from the following expressions:

$$K = \frac{p_o L}{v_{s,MAX}} \quad (C4.7.4.3.2c-1)$$

$$W = \int w(x) dx \quad (C4.7.4.3.2c-2)$$

where:

- L = total length of the bridge (ft)
- $v_{s,MAX}$ = maximum value of $v_s(x)$ (ft)
- $w(x)$ = nominal, unfactored dead load of the bridge superstructure and tributary substructure (kip/ft)

The weight should take into account structural elements and other relevant loads including, but not limited to, pier caps, abutments, columns, and footings. Other loads, such as live loads, may be included. Generally, the inertia effects of live loads are not included in the analysis; however, the probability of a large live load being on the bridge during an earthquake should be considered when designing bridges with high live-to-dead load ratios that are located in metropolitan areas where traffic congestion is likely to occur.

- Calculate the period of the bridge, T_m , using the expression:

$$T_m = 2\pi \sqrt{\frac{W}{gK}} \quad (C4.7.4.3.2c-3)$$

where:

- g = acceleration of gravity (ft/sec.²)

- Calculate the equivalent static earthquake loading p_e from the expression:

$$p_e = \frac{C_{sm} W}{L} \quad (C4.7.4.3.2c-4)$$

where:

- C_{sm} = the dimensionless elastic seismic response coefficient given by Eqs. 3.10.4.2-1, 3.10.4.2-4, or 3.10.4.2-5

p_e = equivalent uniform static seismic loading per unit length of bridge applied to represent the primary mode of vibration (kip/ft)

- Calculate the displacements and member forces for use in design either by applying p_e to the structure and performing a second static analysis or by scaling the results of the first step above by the ratio p_e/p_o .

4.7.4.3.3—Multimode Spectral Method

The multimode spectral analysis method shall be used for bridges in which coupling occurs in more than one of the three coordinate directions within each mode of vibration. As a minimum, linear dynamic analysis using a three-dimensional model shall be used to represent the structure.

The number of modes included in the analysis should be at least three times the number of spans in the model. The design seismic response spectrum as specified in Article 3.10.4 shall be used for each mode.

The member forces and displacements may be estimated by combining the respective response quantities (moment, force, displacement, or relative displacement) from the individual modes by the Complete Quadratic Combination (CQC) method.

C4.7.4.3.3

Member forces and displacements obtained using the CQC combination method are generally adequate for most bridge systems (Wilson et al., 1981).

If the CQC method is not readily available, alternative methods include the square root of the sum of the squares method (SRSS), but this method is best suited for combining responses from well-separated modes. For closely spaced modes, the absolute sum of the modal responses should be used.

4.7.4.3.4—Time-History Method

4.7.4.3.4a—General

Any step-by-step time-history method of analysis used for either elastic or inelastic analysis shall satisfy the requirements of Article 4.7.

The sensitivity of the numerical solution to the size of the time step used for the analysis shall be determined. A sensitivity study shall also be carried out to investigate the effects of variations in assumed material hysteretic properties.

The time histories of input acceleration used to describe the earthquake loads shall be selected in accordance with Article 4.7.4.3.4b.

C4.7.4.3.4

C4.7.4.3.4a

Rigorous methods of analysis are required for critical structures, which are defined in Article 3.10.3, and/or those that are geometrically complex or close to active earthquake faults. Time history methods of analysis are recommended for this purpose, provided care is taken with both the modeling of the structure and the selection of the input time histories of ground acceleration.

4.7.4.3.4b—Acceleration Time Histories

Developed time histories shall have characteristics that are representative of the seismic environment of the site and the local site conditions.

Response-spectrum-compatible time histories shall be used as developed from representative recorded motions. Analytical techniques used for spectrum matching shall be demonstrated to be capable of

C4.7.4.3.4b

Characteristics of the seismic environment to be considered in selecting time histories include:

- Tectonic environment (e.g., subduction zone; shallow crustal faults),
- Earthquake magnitude,

achieving seismologically realistic time series that are similar to the time series of the initial time histories selected for spectrum matching.

Where recorded time histories are used, they shall be scaled to the approximate level of the design response spectrum in the period range of significance. Each time history shall be modified to be response-spectrum-compatible using the time-domain procedure.

At least three response-spectrum-compatible time histories shall be used for each component of motion in representing the design earthquake (ground motions having seven percent probability of exceedance in 75 yr). All three orthogonal components (x , y , and z) of design motion shall be input simultaneously when conducting a nonlinear time-history analysis. The design actions shall be taken as the maximum response calculated for the three ground motions in each principal direction.

If a minimum of seven time histories are used for each component of motion, the design actions may be taken as the mean response calculated for each principal direction.

For near-field sites ($D < 6$ mi), the recorded horizontal components of motion that are selected should represent a near-field condition and should be transformed into principal components before making them response-spectrum-compatible. The major principal component should then be used to represent motion in the fault-normal direction and the minor principal component should be used to represent motion in the fault-parallel direction.

- Type of faulting (e.g., strike-slip; reverse; normal),
- Seismic-source-to-site distance,
- Local site conditions, and
- Design or expected ground-motion characteristics (e.g., design response spectrum, duration of strong shaking, and special ground motion characteristics such as near-fault characteristics)

Dominant earthquake magnitudes and distances, which contribute principally to the probabilistic design response spectra at a site, as determined from national ground motion maps, can be obtained from deaggregation information on the USGS website: <http://geohazards.cr.usgs.gov>.

It is desirable to select time histories that have been recorded under conditions similar to the seismic conditions at the site listed above, but compromises are usually required because of the multiple attributes of the seismic environment and the limited data bank of recorded time histories. Selection of time histories having similar earthquake magnitudes and distances, within reasonable ranges, are especially important parameters because they have a strong influence on response spectral content, response spectral shape, duration of strong shaking, and near-source ground-motion characteristics. It is desirable that selected recorded motions be somewhat similar in overall ground motion level and spectral shape to the design spectrum to avoid using very large scaling factors with recorded motions and very large changes in spectral content in the spectrum-matching approach. If the site is located within 6 mi of an active fault, then intermediate-to-long-period ground-motion pulses that are characteristic of near-source time histories should be included if these types of ground motion characteristics could significantly influence structural response. Similarly, the high short-period spectral content of near-source vertical ground motions should be considered.

Ground motion modeling methods of strong motion seismology are being increasingly used to supplement the recorded ground motion database. These methods are especially useful for seismic settings for which relatively few actual strong motion recordings are available, such as in the central and eastern United States. Through analytical simulation of the earthquake rupture and wave propagation process, these methods can produce seismologically reasonable time series.

Response spectrum matching approaches include methods in which time series adjustments are made in the time domain (Lilhanand and Tseng, 1988; Abrahamson, 1992) and those in which the adjustments are made in the frequency domain (Gasparini and Vanmarcke, 1976; Silva and Lee, 1987; Bolt and Gregor, 1993). Both of these approaches can be used to modify existing time histories to achieve a close match to the design response spectrum while maintaining fairly

well the basic time domain character of the recorded or simulated time histories. To minimize changes to the time domain characteristics, it is desirable that the overall shape of the spectrum of the recorded time history not be greatly different from the shape of the design response spectrum and that the time history initially be scaled so that its spectrum is at the approximate level of the design spectrum before spectrum matching.

Where three-component sets of time histories are developed by simple scaling rather than spectrum matching, it is difficult to achieve a comparable aggregate match to the design spectra for each component of motion when using a single scaling factor for each time history set. It is desirable, however, to use a single scaling factor to preserve the relationship between the components. Approaches for dealing with this scaling issue include:

- use of a higher scaling factor to meet the minimum aggregate match requirement for one component while exceeding it for the other two,
- use of a scaling factor to meet the aggregate match for the most critical component with the match somewhat deficient for other components, and
- Compromising on the scaling by using different factors as required for different components of a time-history set.

While the second approach is acceptable, it requires careful examination and interpretation of the results and possibly dual analyses for application of the higher horizontal component in each principal horizontal direction.

The requirements for the number of time histories to be used in nonlinear inelastic dynamic analysis and for the interpretation of the results take into account the dependence of response on the time domain character of the time histories (duration, pulse shape, pulse sequencing) in addition to their response spectral content.

Additional guidance on developing acceleration time histories for dynamic analysis may be found in publications by the Caltrans Seismic Advisory Board Adhoc Committee (CSABAC) on Soil-Foundation-Structure Interaction (1999) and the U.S. Army Corps of Engineers (2000). CSABAC (1999) also provides detailed guidance on modeling the spatial variation of ground motion between bridge piers and the conduct of seismic soil-foundation-structure interaction (SFSI) analyses. Both spatial variations of ground motion and SFSI may significantly affect bridge response. Spatial variations include differences between seismic wave arrival times at bridge piers (wave passage effect), ground motion incoherence due to seismic wave scattering, and differential site response due to different soil profiles at different bridge piers. For long bridges,

all forms of spatial variations may be important. For short bridges, limited information appears to indicate that wave passage effects and incoherence are, in general, relatively unimportant in comparison to effects of differential site response (Shinozuka et al., 1999; Martin, 1998). Somerville et al. (1999) provide guidance on the characteristics of pulses of ground motion that occur in time histories in the near-fault region.

4.7.4.4—Minimum Support Length Requirements

Support lengths at expansion bearings without restrainers, STUs, or dampers shall either accommodate the greater of the maximum displacement calculated in accordance with the provisions of Article 4.7.4.3, except for bridges in Zone 1, or a percentage of the empirical support length, *N*, specified by Eq. 4.7.4.4-1. Otherwise, longitudinal restrainers complying with Article 3.10.9.5 shall be provided. Bearings restrained for longitudinal movement shall be designed in compliance with Article 3.10.9. The percentages of *N*, applicable to each seismic zone, shall be as specified in Table 4.7.4.4-1.

The empirical support length shall be taken as:

$$N = (8 + 0.02L + 0.08H)(1 + 0.000125S^2) \quad (4.7.4.4-1)$$

where:

- N* = minimum support length measured normal to the centerline of bearing (in.)
- L* = length of the bridge deck to the adjacent expansion joint, or to the end of the bridge deck; for hinges within a span, *L* shall be the sum of the distances to either side of the hinge; for single-span bridges, *L* equals the length of the bridge deck (ft)
- H* = for abutments, average height of columns supporting the bridge deck from the abutment to the next expansion joint (ft)

for columns and/or piers, column, or pier height (ft)

for hinges within a span, average height of the adjacent two columns or piers (ft)

0.0 for single-span bridges (ft)
- S* = skew of support measured from line normal to span (degrees)

C4.7.4.4

Support lengths are equal to the length of the overlap between the girder and the seat as shown in Figure C4.7.4.4-1. To satisfy the minimum values for *N* in this Article, the overall seat width will be larger than *N* by an amount equal to movements due to prestress shortening, creep, shrinkage, and thermal expansion/contraction. The minimum value for *N* given in Eq. 4.7.4.4-1 includes an arbitrary allowance for cover concrete at the end of the girder and face of the seat. If above average cover is used at these locations, *N* should be increased accordingly.

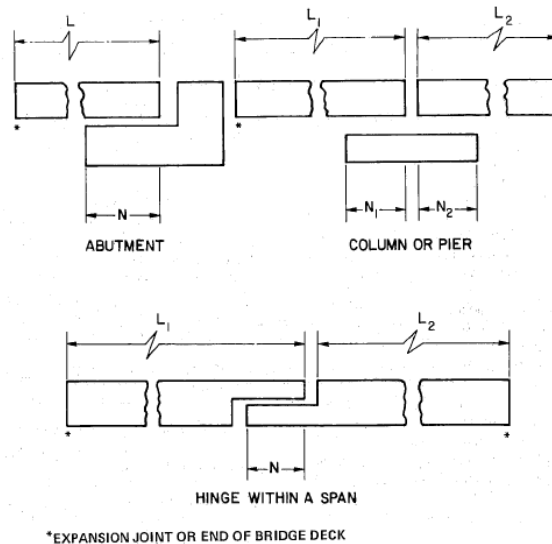

Figure C4.7.4.4-1—Support Length, *N*

Table 4.7.4.4-1—Percentage N by Zone and Acceleration Coefficient A_s , Specified in Eq. 3.10.4.2-2

Zone	Acceleration Coefficient, A_s	Percent, N
1	<0.05	≥75
1	≥0.05	100
2	All Applicable	150
3	All Applicable	150
4	All Applicable	150

4.7.4.5 P - Δ Requirements

The displacement of any column or pier in the longitudinal or transverse direction shall satisfy:

$$\Delta P_u < 0.25\phi M_n \quad (4.7.4.5-1)$$

in which:

$$\Delta = R_d \Delta_e \quad (4.7.4.5-2)$$

- If $T < 1.25T_s$, then:

$$R_d = \left(1 - \frac{1}{R}\right) \frac{1.25T_s}{T} + \frac{1}{R} \quad (4.7.4.5-3)$$

- If $T \geq 1.25T_s$, then:

$$R_d = 1 \quad (4.7.4.5-4)$$

where:

Δ = displacement of the point of contraflexure in the column or pier relative to the point of fixity for the foundation (ft)

Δ_e = displacement calculated from elastic seismic analysis (in.)

T = period of fundamental mode of vibration (sec.)

T_s = corner period specified in Article 3.10.4.2 (sec.)

R = R -factor specified in Article 3.10.7

P_u = axial load on column or pier (kip)

ϕ = flexural resistance factor for column specified in Article 5.10.11.4.1b

M_n = nominal flexural strength of column or pier calculated at the axial load on the column or pier (kip-ft)

C4.7.4.5

Bridges subject to earthquake ground motion may be susceptible to instability due to P - Δ effects. Inadequate strength can result in ratcheting of structural displacements to larger and larger values causing excessive ductility demand on plastic hinges in the columns, large residual deformations, and possibly collapse. The maximum value for Δ given in this Article is intended to limit the displacements such that P - Δ effects will not significantly affect the response of the bridge during an earthquake.

P - Δ effects lead to a loss in strength once yielding occurs in the columns of a bridge. In severe cases, this can result in the force-displacement relationship having a negative slope once yield is fully developed. The value for Δ given by Eq. 4.7.4.5-1 is such that this reduction in strength is limited to 25 percent of the yield strength of the pier or bent.

An explicit P - Δ check was not required in the previous edition of these Specifications but has been introduced herein because two conservative provisions have been relaxed in this revised edition. These are:

- The shape of the response spectrum (Figure 3.10.4.1-1) has been changed from being proportional to $1/T^{2/3}$ to $1/T$. The reason for the $1/T^{2/3}$ provision in the previous edition was to give conservative estimates of force and displacement in bridges with longer periods (>1.0 secs) which, in an indirect way, provided for such effects as P - Δ . With the change of the spectrum to being proportional to $1/T$, an explicit check for P - Δ is now required.
- The flexural resistance factor, ϕ , for seismic design of columns with high axial loads has been increased from a minimum value of 0.5 to 0.9 (Article 5.10.11.4.1b). Use of a low resistance factor led to additional strength being provided in heavily loaded columns that could be used to offset reductions due to P - Δ , in the previous edition. The increased value for ϕ now permitted in Section 5 is a second reason for requiring an explicit check for P - Δ .

4.7.5—Analysis for Collision Loads

Where permitted by the provisions of Section 3, dynamic analysis for ship collision may be replaced by an equivalent static elastic analysis. Where an inelastic analysis is specified, the effect of other loads that may also be present shall be considered.

4.7.6—Analysis of Blast Effects

As a minimum, bridge components analyzed for blast forces should be designed for the dynamic effects resulting from the blast pressure on the structure. The results of an equivalent static analysis shall not be used for this purpose.

C4.7.6

Localized spall and breach damage should be accounted for when designing bridge components for blast forces. Data available at the time these provisions were developed (winter 2010) are not sufficient to develop expressions for estimating the extent of spall/breach in concrete columns; however, spall and breach damage can be estimated for other types of components using guidelines found in Department of Defense (2008a).

The highly impulsive nature of blast loads warrants the consideration of inertial effects during the analysis of a structural component. Past research has demonstrated that, in general, an equivalent static analysis is not acceptable for the design of any structural member subjected to blast loads (Department of Defense, 2008a; Department of Defense, 2002; Bounds, 1998; ASCE, 1997). Information on designing structures to resist blast loads may be found in AASHTO's *Bridge Security Guidelines* (2011), ASCE (1997), Department of Defense (2008a), Conrath, et al. (1999), Biggs (1964), and Bounds (1998).

4.8—ANALYSIS BY PHYSICAL MODELS

4.8.1—Scale Model Testing

To establish and/or to verify structural behavior, the Owner may require the testing of scale models of structures and/or parts thereof. The dimensional and material properties of the structure, as well as its boundary conditions and loads, shall be modeled as accurately as possible. For dynamic analysis, inertial scaling, load/excitation, and damping functions shall be applied as appropriate. For strength limit state tests, factored dead load shall be simulated. The instrumentation shall not significantly influence the response of the model.

4.8.2—Bridge Testing

Existing bridges may be instrumented and results obtained under various conditions of traffic and/or environmental loads or load tested with special purpose vehicles to establish force effects and/or the load-carrying capacity of the bridge.

C4.8.2

These measured force effects may be used to project fatigue life, to serve as a basis for similar designs, to establish permissible weight limits, to aid in issuing permits, or to establish a basis of prioritizing rehabilitation or retrofit.

4.9—REFERENCES

- AASHTO. 1983. *Guide Specification for Seismic Design of Highway Bridges*. American Association of State Highway and Transportation Officials, Washington, DC.
- AASHTO. 2000. *Guide Specifications for Seismic Isolation Design*, Second Edition. American Association of State Highway and Transportation Officials, Washington, DC. Archived.
- AASHTO. 2009. *Standard Specifications for Structural Supports for Highway Signs, Luminaries, and Traffic Signals*, Fifth Edition, LTS-5. American Association of State Highway and Transportation Officials, Washington, DC.
- AASHTO. 2010. *Guide Specifications for Seismic Isolation Design*, Third Edition, GSID-3. American Association of State Highway and Transportation Officials, Washington, DC.
- AASHTO. 2011. *Bridge Security Guidelines*, First Edition, BSG-1. American Association of State Highway and Transportation Officials, Washington, DC.
- Abrahamson, N. A. 1992. "Non-stationary Spectral Matching Program," *Seismological Research Letters*. Vol. 63, No.1. Seismological Society of America, El Cerrito, CA, p.3.
- ACI Committee 435. 1986. *State-of-Art Report on Temperature-Induced Deflections of Reinforced Concrete Members*. SP-86-1. ACI 435.7R-85. American Concrete Institute, Farmington Hills, MI.
- ACI. 2002. *Building Code Requirements for Structural Concrete and Commentary*, ACI 318-02 and ACI 318R-02. American Concrete Institute, Farmington, Hill, MI.
- AISC. 1993. "Load and Resistance Factor Design." *Specification for Structural Steel Buildings and Commentary*, 2nd Edition. American Institute of Steel Construction, Chicago, IL.
- AISC. 1999. *LRFD Specifications for Structural Steel Buildings*, Third Edition. American Institute of Steel Construction, Chicago, IL.
- Allen, T. M. 2005. *Development of Geotechnical Resistance Factors and Downdrag Load Factors for LRFD Foundation Strength Limit State Design*, FHWA-NHI-05-052. Federal Highway Administration, U.S. Department of Transportation, Washington, DC.
- Aristizabal, J. D. 1987. "Tapered Beam and Column Elements in Unbraced Frame Structures." *Journal of Computing in Civil Engineering*, Vol. 1, No. 1, January 1987, pp. 35–49.
- ASCE. 1961. "Wind Forces on Structures." *Transactions of the ASCE*, American Society of Civil Engineers, New York, NY, Vol. 126, No. 3269.
- ASCE. 1971. "Guide for Design of Transmission Towers." *Manuals and Reports on Engineering Practice*, No. 52, American Society of Civil Engineers, New York, NY, pp. 1–47.
- ASCE Committee on Cable-Suspended Bridges. 1991. *Guidelines for Design of Cable-Stayed Bridges*. Committee on Cable-Suspended Bridges, American Society of Civil Engineers, New York, NY.
- ASCE Task Committee on Effective Length. 1997. *Effective Length and Notional Load Approaches for Assessing Frame Stability: Implementation for American Steel Design*. Task Committee on Effective Length, American Society of Civil Engineers, Reston, VA.
- Astaneh-Asl, A., and S. C. Goel. 1984. "Cyclic In-Plane Buckling of Double Angle Bracing." *Journal of Structural Engineering*, American Society of Civil Engineers, New York, NY, Vol. 110, No. 9, September 1984, pp. 2036–2055.
- Astaneh-Asl, A., S. C. Goel, and R. D. Hanson. 1985. "Cyclic Out-of-Plane Buckling of Double Angle Bracing." *Journal of Structural Engineering*, American Society of Civil Engineers, New York, NY, Vol. 111, No. 5, May 1985, pp. 1135–1153.

- ATC. 1981. *Seismic Design Guidelines for Highway Bridges*. ATC-6. Applied Technology Council, Berkeley, CA.
- Basu, S., and M. Chi. 1981a. *Analytic Study for Fatigue of Highway Bridge Cables*, FHWA-RD-81-090. Federal Highway Administration, U.S. Department of Transportation, Washington, DC.
- Basu, S., and M. Chi. 1981b. *Design Manual for Bridge Structural Members under Wind-Induced Excitation*, FHWA-TS-81-206. Federal Highway Administration, U.S. Department of Transportation, Washington, DC.
- Biggs, J. M. 1964. *Introduction to Structural Dynamics*. McGraw-Hill Book Company, New York, NY.
- Bolt, B. A., and N. J. Gregor. 1993. *Synthesized Strong Ground Motions for the Seismic Condition Assessment of the Eastern Portion of the San Francisco Bay Bridge*, Report UCB/EERC-93.12. Earthquake Engineering Research Center, University of California at Berkeley, Berkeley, CA.
- BridgeTech, Inc. 2007. *Simplified Live Load Distribution Factor Equations*, NCHRP Report 592. National Cooperative Highway Research Program, Transportation Research Board, National Research Council, Washington, DC.
- Burgan, B. A. and P. J. Dowling. 1985. *The Collapse Behavior of Box Girder Compression Flanges—Numerical Modeling of Experimental Results*, CESLIC Report BG 83. Imperial College, University of London, UK.
- Chen, S. S., A. J. Aref, I.-S. Ahn, M. Chiewanichakorn, J. A. Carpenter, A. Nottis, and I. Kalpakidis. 2005. *Effective Slab Width for Composite Steel Bridge Members*, NCHRP Report 543. Transportation Research Board, National Research Council, Washington, DC.
- Chen, W. F., and E. M. Lui. 1991. *Stability Design of Steel Frames*. CRC Press, Boca Raton, FL.
- Clough, R. W., and J. Penzian. 1975. *Dynamics of Structures*. McGraw Hill, New York, NY.
- CSABAC. 1999. *Seismic Soil-Foundation-Structure Interaction*, final report. Caltrans Seismic Advisory Board Ad Hoc Committee on Soil-Foundation-Structure Interaction (CSABAC), California Department of Transportation, Sacramento, CA.
- Danon, J. R. and W. L. Gamble. 1977. "Time-Dependent Deformations and Losses in Concrete Bridges Built by the Cantilever Method." *Civil Engineering Studies, Structural Research Series*. University of Illinois at Urbana-Champaign, Department of Civil Engineering, No. 437, January 1977, p. 169.
- Davis, R., J. Kozak, and C. Scheffey. 1965. *Structural Behavior of a Box Girder Bridge*. State of California Highway Transportation Agency, Department of Public Works, Division of Highways, Bridge Department, in cooperation with U.S. Department of Commerce, Bureau of Public Roads, and the University of California, Berkeley, CA, May 1965.
- Disque, R. O. 1973. "Inelastic K-Factor in Design." *AISC Engineering Journal*, American Institute of Steel Construction, Chicago, IL, Vol. 10, 2nd Qtr., p. 33.
- Dowling, P. J., J. E. Harding, and P. A. Frieze, eds. 1977. *Steel Plated Structures*. In Proc., Imperial College, Crosby Lockwood, London, UK.
- Duan, L. and W. F. Chen. 1988. "Effective Length Factor for Columns in Braced Frames." *Journal of Structural Engineering*, American Society of Civil Engineers, Vol. 114, No. 10, October, 1988, pp. 2357–2370.
- Duan, L., and W. F. Chen. 1989. "Effective Length Factor for Columns in Unbraced Frames." *Journal of Structural Engineering*, American Society of Civil Engineers, New York, NY, Vol. 115, No. 1, January 1989, pp. 149–165.
- Duan, L., W. S. King, and W. F. Chen. 1993. "K-factor Equation to Alignment Charts for Column Design." *ACI Structural Journal*, Vol. 90, No. 3, May–June, 1993, pp. 242–248.
- Eby, C. C., J. M. Kulicki, C. N. Kostem, and M. A. Zellin. 1973. *The Evaluation of St. Venant Torsional Constants for Prestressed Concrete I-Beams*. Fritz Laboratory Report No. 400.12. Lehigh University, Bethlehem, PA.

FHWA. 2012. *Manual for Design, Construction, and Maintenance of Orthotropic Steel Deck Bridges*. Federal Highway Administration, U.S. Department of Transportation, Washington, DC.

Frederick, G. R., C. V. Ardis, K. M. Tarhini, and B. Koo. 1988. "Investigation of the Structural Adequacy of C 850 Box Culverts," *Transportation Research Record* 1191, Transportation Research Board, National Research Council, Washington, DC.

Galambos, T. V., ed. 1998. *Guide to Stability Design for Metal Structures*, 5th Edition. Structural Stability Research Council. John Wiley and Sons, Inc., New York, NY.

Gasparini, D., and E. H. Vanmarcke. 1976. *SIMQKE: A Program for Artificial Motion Generation*. Department of Civil Engineering, Massachusetts Institute of Technology, Cambridge, MA.

Ghali, A., and A. M. Neville. 1989. *Structural Analysis: A Unified Classical and Matrix Approach*, 3rd Edition. Chapman Hall, New York, NY.

Goel, S. C., and A. A. El-Tayem. 1986. "Cyclic Load Behavior of Angle X-Bracing." *Journal of Structural Engineering*, American Society of Civil Engineers, New York, NY, Vol. 112, No. 11, November 1986, pp. 2528–2539.

Guyan, R. J. 1965. "Reduction of Stiffness and Mass Matrices." *AIAA Journal*, American Institute of Aeronautics and Astronautics, Reston, VA, Vol. 3, No. 2, February 1965, p. 380.

Hall, D. H., and C. H. Yoo. 1996. *I-Girder Curvature Study*. Interim Report, NCHRP Project 12-38 submitted to NCHRP, Transportation Research Board, Washington, DC, pp. 1–72 (or see Appendix A of NCHRP Report 424: Improved Design Specifications for Horizontally Curved Steel Highway Bridges, pp. 49–74).

Haroun, N. M., and R. Sheperd. 1986. "Inelastic Behavior of X-Bracing in Plane Frames." *Journal of Structural Engineering*, American Society of Civil Engineers, New York, NY, Vol. 112, No. 4, April 1986, pp. 764–780.

Higgins, C. 2003. "LRFD Orthotropic Plate Model for Determining Live Load Moments in Concrete Filled Grid Bridge Decks." *Journal of Bridge Engineering*, American Society of Civil Engineers, Reston, VA, January/February 2003, pp. 20–28.

Highway Engineering Division. 1991. *Ontario Highway Bridge Design Code*. Highway Engineering Division, Ministry of Transportation and Communications, Toronto, Canada.

Hindi, W. A. 1991. "Behavior and Design of Stiffened Compression Flanges of Steel Box Girder Bridges." Ph.D. Thesis. University of Surrey, Guilford, UK.

Homberg, H. 1968. *Fahrbahnplatten mit Verandlicher Dicke*. Springer-Verlag, New York, NY.

James, R. W. 1984. "Behavior of ASTM C 850 Concrete Box Culverts Without Shear Connectors," *Transportation Research Record* 1001, Transportation Research Board, National Research Council, Washington, DC.

Jetteur, P. et al. 1984. "Interaction of Shear Lag with Plate Buckling in Longitudinally Stiffened Compression Flanges," *Acta Technica CSAV*. Akademie Ved Ceske Republiky, Czech Republic, No. 3, p. 376.

Johnston, S. B., and A. H. Mattock. 1967. *Lateral Distribution of Load in Composite Box Girder Bridges*. Highway Research Record No. 167, Highway Research Board, Washington, DC.

Karabalis, D. L. 1983. "Static, Dynamic and Stability Analysis of Structures Composed of Tapered Beams." *Computers and Structures*, Vol. 16, No. 6, pp. 731–748.

Ketchum, M. S. 1986. "Short Cuts for Calculating Deflections." *Structural Engineering Practice: Analysis, Design, Management*, Vol. 3, No. 2, pp. 83–91.

King, Csagoly P. F., and J. W. Fisher. 1975. *Field Testing of the Aquasabon River Bridge*. Ontario, Canada.

Lamas, A. R. G. and P. J. Dowling. 1980. "Effect of Shear Lag on the Inelastic Buckling Behavior of Thin-Walled Structures." In *Thin-Walled Structures*, J. Rhodes & A.C. Walker, eds., Granada, London, p. 100.

Liu, H. 1991. *Wind Engineering: A Handbook for Structural Engineers*. Prentice Hall, Englewood Cliffs, NJ.

Manual for Design, Construction and Maintenance of Orthotropic Steel Bridges. In development.

McGrath, T. J., A. A. Liepins, J. L. Beaver, and B. P. Strohmman. 2004. *Live Load Distribution Widths for Reinforced Concrete Box Culverts*. A Study for the Pennsylvania Department of Transportation, Simpson Gumpertz & Heger Inc., Waltham, MA.

Modjeski and Masters, Inc. 1994. *Report to Pennsylvania Department of Transportation*. Harrisburg, PA.

Moffatt, K. R., and P. J. Dowling. 1975. "Shear Lag in Steel Box Girder Bridges." *The Structural Engineer*, October 1975, pp. 439–447.

Moffatt, K. R., and P. J. Dowling. 1976. "Discussion." *The Structural Engineer*, August 1976, pp. 285–297.

Nassif, H., A.-A. Talat, and S. El-Tawil. 2006. "Effective Flange Width Criteria for Composite Steel Girder Bridges," Annual Meeting CD-ROM, Transportation Research Board, National Research Council, Washington, DC.

Nettleton, D. A. 1977. *Arch Bridges*. Bridge Division, Office of Engineering, Federal Highway Administration, U.S. Department of Transportation, Washington, DC.

Nutt, Redfield and Valentine in association with David Evans and Associates and Zocon Consulting Engineers. 2008. Development of Design Specifications and Commentary for Horizontally Curved Concrete Box-Girder Bridges, NCHRP Report 620. Transportation Research Board, National Research Council, Washington, DC.

Paikowsky, S. G., with contributions from B. Birgisson, M. McVay, T. Nguyen, C. Kuo, G. Baecher, B. Ayyab, K. Stenersen, K. O'Malley, L. Chernauskas, and M. O'Neill. 2004. *Load and Resistance Factor Design (LRFD) for Deep Foundations*, NCHRP (Final) Report 507. Transportation Research Board, National Research Council, Washington, DC.

Paz, M. 1984. "Dynamic Condensation." *AIAA Journal*, American Institute of Aeronautics and Astronautics, Reston, VA, Vol. 22, No. 5, May 1984, pp. 724–727.

Paz, M. 1985. *Structural Dynamics*, 2nd Edition. Van Nosstrand Reinhold Company, New York, NY.

Peck, R. B., W. E. Hanson, and T. H. Thornburn. 1974. *Foundation Engineering*, 2nd Edition. John Wiley and Sons, Inc., New York, NY.

Podolny, W., and J. B. Scalzi. 1986. *Construction and Design of Cable-Stayed Bridges*, 2nd Edition. Wiley-Interscience, New York, NY.

Przemieniecki, J. S. 1968. *Theory of Matrix Structural Analysis*. McGraw Hill, New York, NY.

Pucher, A. 1964. *Influence Surfaces of Elastic Plates*, 4th Edition. Springer-Verlag, New York, NY.

Puckett, J. A. and M. Jablin. 2009. "AASHTO T-05 Report." Correspondence, March 2009.

Richardson, Gordon and Associates (presently HDR, Pittsburgh office). 1976. "Curved Girder Workshop Lecture Notes." Prepared under Contract No. DOT-FH-11-8815. Federal Highway Administration, U.S. Department of Transportation. Four-day workshop presented in Albany, Denver, and Portland, September–October 1976, pp. 31–38.

Salmon, C. G., and J. E. Johnson. 1990. *Steel Structures: Design and Behavior, Emphasizing Load, and Resistance Factor Design*, 3rd Edition. Harper and Row, New York, NY.

Scanlan, R. H. 1975. *Recent Methods in the Application of Test Results to the Wind Design of Long Suspended-Span Bridges*, FHWA-RD-75-115. Federal Highway Administration, U.S. Department of Transportation, Washington, DC.

- Shinozuka, M., V. Saxena, and G. Deodatis. 1999. *Effect of Spatial Variation of Ground Motion on Highway Structures*, Draft Final Report for MCEER Highway Project. Submitted to Multidisciplinary Center for Earthquake Engineering Research, University at Buffalo, Buffalo, NY.
- Shushkewich, K. W. 1986. "Time-Dependent Analysis of Segmental Bridges." *Computers and Structures*, Vol. 23, No. 1, pp. 95–118.
- Silva, W., and K. Lee. 1987. "State-of-the-Art for Assessing Earthquake Hazards in the United State: Report 24," *WES RASCAL Code for Synthesizing Earthquake Ground Motions*, Miscellaneous Paper 5-73-1. U. S. Army Engineer Waterways Experiment Station, Vicksburg, MS.
- Simiu, E. 1973. "Logarithmic Profiles and Design Wind Speeds." *Journal of the Mechanics Division*, American Society of Civil Engineers, New York, NY, Vol. 99, No. EM5, October 1973, pp. 1073–1083.
- Simiu, E. 1976. "Equivalent Static Wind Loads for Tall Building Design." *Journal of the Structures Division*, American Society of Civil Engineers, New York, NY, Vol. 102, No. ST4, April 1976, pp. 719–737.
- Simiu, E., and R. H. Scanlan. 1978. *Wind Effects on Structures*. Wiley-Interscience, New York, NY.
- Smith, Jr., C. V. 1976. "On Inelastic Column Buckling." *AISC Engineering Journal*, American Institute of Steel Construction, Chicago, IL, Vol. 13, 3rd Qtr., pp. 86–88.
- Song, S. T., Y. H. Chai, and S. E. Hida. 2001. *Live Load Distribution in Multi-Cell Box-Girder Bridges and its Comparisons with AASHTO LRFD Bridge Design Specifications*, UCD-STR-01-1, University of California, Davis, CA, July 2001.
- Song, S. T., Y. H. Chai, and S. E. Hida. 2003. "Live Load Distribution Factors for Concrete Box-Girder Bridges." *Journal of Bridge Engineering*, American Society of Civil Engineers, Vol. 8, No. 5, pp. 273–280.
- Tobias, D. H., R. E. Anderson, S. Y. Kayyat, Z. B. Uzman, and K. L. Riechers. 2004. "Simplified AASHTO Load and Resistance Factor Design Girder Live Load Distribution in Illinois," *Journal of Bridge Engineering*. American Society of Civil Engineers, Reston, VA, Vol. 9, No. 6, November/December 2004, pp. 606–613.
- Troitsky, M. S. 1977. *Cable-Stayed Bridges*. Crosby Lockwood Staples, London, England, p. 385.
- Tung, D. H. H., and R. S. Fountain. 1970. "Approximate Torsional Analysis of Curved Box Girders by the M/R-Method." *Engineering Journal*, American Institute of Steel Construction, Vol. 7, No. 3, pp. 65–74.
- United States Steel. 1984. "V-Load Analysis." Available from the National Steel Bridge Alliance, Chicago, IL, pp. 1–56.
- USACE. 2003. *Time History Dynamic Analysis of Concrete Hydraulic Structures*, USACE Engineering Circular EC1110-2-6051. U.S. Army Corp of Engineers,
- White, D. W., and J. F. Hajjar. 1991. "Application of Second-Order Elastic Analysis in LRFD: Research to Practice." *AISC Engineering Journal*, American Institute of Steel Construction, Chicago, IL, Vol. 28, No. 4, pp. 133–148.
- Wilson, E. L., A. Der Kiureghian, and E. P. Bayo. 1981. "A Replacement for the SRSS Method in Seismic Analysis." *International Journal of Earthquake Engineering and Structural Dynamics*, Vol. 9, pp. 187–194.
- Wolchuk, R. 1963. *Design Manual for Orthotropic Steel Plate Deck Bridges*. American Institute of Steel Construction, Chicago, IL.
- Wolchuk, R. 1990. "Steel-Plate-Deck Bridges." In *Structural Engineering Handbook*, 3rd Edition. E. H. Gaylord and C. N. Gaylord, eds. McGraw-Hill, New York, NY, pp. 19-1–19-28.

Wright, R. N., and S. R. Abdel-Samad. 1968. "BEF Analogy for Analysis of Box Girders." *Journal of the Structural Division*, American Society of Civil Engineers, Vol. 94, No. ST7, pp. 1719–1743.

Yura, J. A. 1971. "The Effective Length of Columns in Unbraced Frames." *AISC Engineering Journal*, American Institute of Steel Construction, Chicago, IL, Vol. 8, No. 2., April 1971, pp. 37–42.

Yen, B. T., T. Huang, and D. V. VanHorn. 1995. *Field Testing of a Steel Bridge and a Prestressed Concrete Bridge*, Research Project No. 86-05, Final Report, Vol. II, Pennsylvania Department of Transportation Office of Research and Special Studies, Fritz Engineering Laboratory Report No. 519.2, Lehigh University, Bethlehem, PA.

Zokaie, T. 1998, 1999, 2000. Private Correspondence.

Zokaie, T., T. A. Osterkamp, and R. A. Imbsen. 1991. *Distribution of Wheel Loads on Highway Bridges*, NCHRP Report 12-2611. Transportation Research Board, National Research Council, Washington, DC.

APPENDIX A4—DECK SLAB DESIGN TABLE

Table A4-1 may be used in determining the design moments for different girder arrangements. The following assumptions and limitations were used in developing this table and should be considered when using the listed values for design:

- The moments are calculated using the equivalent strip method as applied to concrete slabs supported on parallel girders.
- Multiple presence factors and the dynamic load allowance are included in the tabulated values.
- See Article 4.6.2.1.6 for the distance between the center of the girders to the location of the design sections for negative moments in the deck. Interpolation between the listed values may be used for distances other than those listed in Table A4-1.
- The moments are applicable for decks supported on at least three girders and having a width of not less than 14.0 ft between the centerlines of the exterior girders.
- The moments represent the upper bound for the moments in the interior regions of the slab and, for any specific girder spacing, were taken as the maximum value calculated, assuming different number of girders in the bridge cross-section. For each combination of girder spacing and number of girders, the following two cases of overhang width were considered:
 - (a) Minimum total overhang width of 21.0 in. measured from the center of the exterior girder, and
 - (b) Maximum total overhang width equal to the smaller of 0.625 times the girder spacing and 6.0 ft.

A railing system width of 21.0 in. was used to determine the clear overhang width. For other widths of railing systems, the difference in the moments in the interior regions of the deck is expected to be within the acceptable limits for practical design.

- The moments do not apply to the deck overhangs and the adjacent regions of the deck that need to be designed taking into account the provisions of Article A13.4.1.
- It was found that the effect of two 25^k axles of the tandem, placed at 4.0 ft from each other, produced maximum effects under each of the tires approximately equal to the effect of the 32^k truck axle. The tandem produces a larger total moment, but this moment is spread over a larger width. It was concluded that repeating calculations with a different strip width for the tandem would not result in a significant difference.

Table A4-1—Maximum Live Load Moments per Unit Width, kip-ft/ft

S	Positive Moment	Negative Moment							
		Distance from CL of Girder to Design Section for Negative Moment							
		0.0 in.	3 in.	6 in.	9 in.	12 in.	18 in.	24 in.	
4'	-0"	4.68	2.68	2.07	1.74	1.60	1.50	1.34	1.25
4'	-3"	4.66	2.73	2.25	1.95	1.74	1.57	1.33	1.20
4'	-6"	4.63	3.00	2.58	2.19	1.90	1.65	1.32	1.18
4'	-9"	4.64	3.38	2.90	2.43	2.07	1.74	1.29	1.20
5'	-0"	4.65	3.74	3.20	2.66	2.24	1.83	1.26	1.12
5'	-3"	4.67	4.06	3.47	2.89	2.41	1.95	1.28	0.98
5'	-6"	4.71	4.36	3.73	3.11	2.58	2.07	1.30	0.99
5'	-9"	4.77	4.63	3.97	3.31	2.73	2.19	1.32	1.02
6'	-0"	4.83	4.88	4.19	3.50	2.88	2.31	1.39	1.07
6'	-3"	4.91	5.10	4.39	3.68	3.02	2.42	1.45	1.13
6'	-6"	5.00	5.31	4.57	3.84	3.15	2.53	1.50	1.20
6'	-9"	5.10	5.50	4.74	3.99	3.27	2.64	1.58	1.28
7'	-0"	5.21	5.98	5.17	4.36	3.56	2.84	1.63	1.37
7'	-3"	5.32	6.13	5.31	4.49	3.68	2.96	1.65	1.51
7'	-6"	5.44	6.26	5.43	4.61	3.78	3.15	1.88	1.72
7'	-9"	5.56	6.38	5.54	4.71	3.88	3.30	2.21	1.94
8'	-0"	5.69	6.48	5.65	4.81	3.98	3.43	2.49	2.16
8'	-3"	5.83	6.58	5.74	4.90	4.06	3.53	2.74	2.37
8'	-6"	5.99	6.66	5.82	4.98	4.14	3.61	2.96	2.58
8'	-9"	6.14	6.74	5.90	5.06	4.22	3.67	3.15	2.79
9'	-0"	6.29	6.81	5.97	5.13	4.28	3.71	3.31	3.00
9'	-3"	6.44	6.87	6.03	5.19	4.40	3.82	3.47	3.20
9'	-6"	6.59	7.15	6.31	5.46	4.66	4.04	3.68	3.39
9'	-9"	6.74	7.51	6.65	5.80	4.94	4.21	3.89	3.58
10'	-0"	6.89	7.85	6.99	6.13	5.26	4.41	4.09	3.77
10'	-3"	7.03	8.19	7.32	6.45	5.58	4.71	4.29	3.96
10'	-6"	7.17	8.52	7.64	6.77	5.89	5.02	4.48	4.15
10'	-9"	7.32	8.83	7.95	7.08	6.20	5.32	4.68	4.34
11'	-0"	7.46	9.14	8.26	7.38	6.50	5.62	4.86	4.52
11'	-3"	7.60	9.44	8.55	7.67	6.79	5.91	5.04	4.70
11'	-6"	7.74	9.72	8.84	7.96	7.07	6.19	5.22	4.87
11'	-9"	7.88	10.01	9.12	8.24	7.36	6.47	5.40	5.05
12'	-0"	8.01	10.28	9.40	8.51	7.63	6.74	5.56	5.21
12'	-3"	8.15	10.55	9.67	8.78	7.90	7.02	5.75	5.38
12'	-6"	8.28	10.81	9.93	9.04	8.16	7.28	5.97	5.54
12'	-9"	8.41	11.06	10.18	9.30	8.42	7.54	6.18	5.70
13'	-0"	8.54	11.31	10.43	9.55	8.67	7.79	6.38	5.86
13'	-3"	8.66	11.55	10.67	9.80	8.92	8.04	6.59	6.01
13'	-6"	8.78	11.79	10.91	10.03	9.16	8.28	6.79	6.16
13'	-9"	8.90	12.02	11.14	10.27	9.40	8.52	6.99	6.30
14'	-0"	9.02	12.24	11.37	10.50	9.63	8.76	7.18	6.45
14'	-3"	9.14	12.46	11.59	10.72	9.85	8.99	7.38	6.58
14'	-6"	9.25	12.67	11.81	10.94	10.08	9.21	7.57	6.72
14'	-9"	9.36	12.88	12.02	11.16	10.30	9.44	7.76	6.86
15'	-0"	9.47	13.09	12.23	11.37	10.51	9.65	7.94	7.02

SECTION 5: CONCRETE STRUCTURES

TABLE OF CONTENTS

5.1—SCOPE.....	5-1
5.2—DEFINITIONS.....	5-1
5.3—NOTATION.....	5-5
5.4—MATERIAL PROPERTIES	5-12
5.4.1—General.....	5-12
5.4.2—Normal Weight and Structural Lightweight Concrete	5-13
5.4.2.1—Compressive Strength.....	5-13
5.4.2.2—Coefficient of Thermal Expansion.....	5-15
5.4.2.3—Shrinkage and Creep.....	5-15
5.4.2.3.1—General	5-15
5.4.2.3.2—Creep	5-15
5.4.2.3.3—Shrinkage.....	5-17
5.4.2.4—Modulus of Elasticity.....	5-18
5.4.2.5—Poisson’s Ratio	5-18
5.4.2.6—Modulus of Rupture.....	5-18
5.4.2.7—Tensile Strength.....	5-19
5.4.3—Reinforcing Steel	5-19
5.4.3.1—General	5-19
5.4.3.2—Modulus of Elasticity.....	5-20
5.4.3.3—Special Applications	5-20
5.4.4—Prestressing Steel	5-20
5.4.4.1—General	5-20
5.4.4.2—Modulus of Elasticity.....	5-21
5.4.5—Post-Tensioning Anchorages and Couplers	5-21
5.4.6—Ducts.....	5-22
5.4.6.1—General	5-22
5.4.6.2—Size of Ducts.....	5-22
5.4.6.3—Ducts at Deviation Saddles.....	5-23
5.5—LIMIT STATES.....	5-23
5.5.1—General.....	5-23
5.5.2—Service Limit State.....	5-23
5.5.3—Fatigue Limit State.....	5-23
5.5.3.1—General	5-23
5.5.3.2—Reinforcing Bars.....	5-24
5.5.3.3—Prestressing Tendons	5-25
5.5.3.4—Welded or Mechanical Splices of Reinforcement.....	5-25
5.5.4—Strength Limit State	5-26
5.5.4.1—General	5-26
5.5.4.2—Resistance Factors	5-26
5.5.4.2.1—Conventional Construction	5-26
5.5.4.2.2—Segmental Construction.....	5-28

5.5.4.2.3—Special Requirements for Seismic Zones 2, 3, and 4	5-28
5.5.4.3—Stability	5-29
5.5.5—Extreme Event Limit State	5-29
5.6—DESIGN CONSIDERATIONS	5-29
5.6.1—General	5-29
5.6.2—Effects of Imposed Deformation	5-29
5.6.3—Strut-and-Tie Model	5-29
5.6.3.1—General	5-29
5.6.3.2—Structural Modeling	5-30
5.6.3.3—Proportioning of Compressive Struts	5-31
5.6.3.3.1—Strength of Unreinforced Strut	5-31
5.6.3.3.2—Effective Cross-Sectional Area of Strut	5-32
5.6.3.3.3—Limiting Compressive Stress in Strut	5-33
5.6.3.3.4—Reinforced Strut	5-33
5.6.3.4—Proportioning of Tension Ties	5-33
5.6.3.4.1—Strength of Tie	5-33
5.6.3.4.2—Anchorage of Tie	5-34
5.6.3.5—Proportioning of Node Regions	5-34
5.6.3.6—Crack Control Reinforcement	5-34
5.7—DESIGN FOR FLEXURAL AND AXIAL FORCE EFFECTS	5-35
5.7.1—Assumptions for Service and Fatigue Limit States	5-35
5.7.2—Assumptions for Strength and Extreme Event Limit States	5-36
5.7.2.1—General	5-36
5.7.2.2—Rectangular Stress Distribution	5-38
5.7.3—Flexural Members	5-39
5.7.3.1—Stress in Prestressing Steel at Nominal Flexural Resistance	5-39
5.7.3.1.1—Components with Bonded Tendons	5-39
5.7.3.1.2—Components with Unbonded Tendons	5-40
5.7.3.1.3—Components with Both Bonded and Unbonded Tendons	5-40
5.7.3.1.3a—Detailed Analysis	5-40
5.7.3.1.3b—Simplified Analysis	5-41
5.7.3.2—Flexural Resistance	5-41
5.7.3.2.1—Factored Flexural Resistance	5-41
5.7.3.2.2—Flanged Sections	5-41
5.7.3.2.3—Rectangular Sections	5-42
5.7.3.2.4—Other Cross-Sections	5-43
5.7.3.2.5—Strain Compatibility Approach	5-43
5.7.3.3—Limits for Reinforcement	5-43
5.7.3.3.1—Maximum Reinforcement	5-43
5.7.3.3.2—Minimum Reinforcement	5-43
5.7.3.4—Control of Cracking by Distribution of Reinforcement	5-45
5.7.3.5—Moment Redistribution	5-47
5.7.3.6—Deformations	5-47
5.7.3.6.1—General	5-47
5.7.3.6.2—Deflection and Camber	5-47

5.7.3.6.3—Axial Deformation	5-48
5.7.4—Compression Members	5-48
5.7.4.1—General	5-48
5.7.4.2—Limits for Reinforcement.....	5-49
5.7.4.3—Approximate Evaluation of Slenderness Effects	5-50
5.7.4.4—Factored Axial Resistance	5-51
5.7.4.5—Biaxial Flexure	5-52
5.7.4.6—Spirals and Ties	5-53
5.7.4.7—Hollow Rectangular Compression Members	5-53
5.7.4.7.1—Wall Slenderness Ratio.....	5-53
5.7.4.7.2—Limitations on the Use of the Rectangular Stress Block Method	5-54
5.7.4.7.2a—General	5-54
5.7.4.7.2b—Refined Method for Adjusting Maximum Usable Strain Limit.....	5-54
5.7.4.7.2c—Approximate Method for Adjusting Factored Resistance.....	5-55
5.7.5—Bearing.....	5-55
5.7.6—Tension Members	5-56
5.7.6.1—Factored Tension Resistance	5-56
5.7.6.2—Resistance to Combinations of Tension and Flexure.....	5-56
5.8—SHEAR AND TORSION.....	5-56
5.8.1—Design Procedures	5-56
5.8.1.1—Flexural Regions.....	5-56
5.8.1.2—Regions Near Discontinuities	5-57
5.8.1.3—Interface Regions.....	5-57
5.8.1.4—Slabs and Footings.....	5-57
5.8.1.5—Webs of Curved Post-Tensioned Box Girder Bridges	5-57
5.8.2—General Requirements.....	5-57
5.8.2.1—General	5-57
5.8.2.2—Modifications for Lightweight Concrete	5-59
5.8.2.3—Transfer and Development Lengths.....	5-60
5.8.2.4—Regions Requiring Transverse Reinforcement	5-60
5.8.2.5—Minimum Transverse Reinforcement	5-60
5.8.2.6—Types of Transverse Reinforcement	5-61
5.8.2.7—Maximum Spacing of Transverse Reinforcement	5-62
5.8.2.8—Design and Detailing Requirements	5-62
5.8.2.9—Shear Stress on Concrete	5-63
5.8.3—Sectional Design Model.....	5-64
5.8.3.1—General	5-64
5.8.3.2—Sections Near Supports.....	5-65
5.8.3.3—Nominal Shear Resistance	5-67
5.8.3.4—Procedures for Determining Shear Resistance.....	5-68
5.8.3.4.1—Simplified Procedure for Nonprestressed Sections.....	5-69
5.8.3.4.2—General Procedure	5-69
5.8.3.4.3—Simplified Procedure for Prestressed and Nonprestressed Sections.....	5-73
5.8.3.5—Longitudinal Reinforcement.....	5-75
5.8.3.6—Sections Subjected to Combined Shear and Torsion	5-77

5.8.3.6.1—Transverse Reinforcement	5-77
5.8.3.6.2—Torsional Resistance	5-77
5.8.3.6.3—Longitudinal Reinforcement	5-77
5.8.4—Interface Shear Transfer—Shear Friction	5-78
5.8.4.1—General	5-78
5.8.4.2—Computation of the Factored Interface Shear Force, V_{ui} , for Girder/Slab Bridges	5-80
5.8.4.3—Cohesion and Friction Factors	5-82
5.8.4.4—Minimum Area of Interface Shear Reinforcement	5-83
5.8.5—Principal Stresses in Webs of Segmental Concrete Bridges	5-84
5.8.6—Shear and Torsion for Segmental Box Girder Bridges	5-85
5.8.6.1—General	5-85
5.8.6.2—Loading	5-85
5.8.6.3—Regions Requiring Consideration of Torsional Effects	5-86
5.8.6.4—Torsional Reinforcement	5-87
5.8.6.5—Nominal Shear Resistance	5-88
5.8.6.6—Reinforcement Details	5-89
5.9—PRESTRESSING	5-90
5.9.1—General Design Considerations	5-90
5.9.1.1—General	5-90
5.9.1.2—Specified Concrete Strengths	5-91
5.9.1.3—Buckling	5-91
5.9.1.4—Section Properties	5-91
5.9.1.5—Crack Control	5-91
5.9.1.6—Tendons with Angle Points or Curves	5-91
5.9.2—Stresses Due to Imposed Deformation	5-92
5.9.3—Stress Limitations for Prestressing Tendons	5-92
5.9.4—Stress Limits for Concrete	5-93
5.9.4.1—For Temporary Stresses before Losses—Fully Prestressed Components	5-93
5.9.4.1.1—Compression Stresses	5-93
5.9.4.1.2—Tension Stresses	5-93
5.9.4.2—For Stresses at Service Limit State after Losses—Fully Prestressed Components	5-95
5.9.4.2.1—Compression Stresses	5-95
5.9.4.2.2—Tension Stresses	5-97
5.9.5—Loss of Prestress	5-98
5.9.5.1—Total Loss of Prestress	5-98
5.9.5.2—Instantaneous Losses	5-98
5.9.5.2.1—Anchorage Set	5-98
5.9.5.2.2—Friction	5-99
5.9.5.2.2a—Pretensioned Construction	5-99
5.9.5.2.2b—Post-Tensioned Construction	5-99
5.9.5.2.3—Elastic Shortening	5-101
5.9.5.2.3a—Pretensioned Members	5-101
5.9.5.2.3b—Post-Tensioned Members	5-102
5.9.5.2.3c—Combined Pretensioning and Post-Tensioning	5-103
5.9.5.3—Approximate Estimate of Time-Dependent Losses	5-103

5.9.5.4—Refined Estimates of Time-Dependent Losses	5-104
5.9.5.4.1—General	5-104
5.9.5.4.2—Losses: Time of Transfer to Time of Deck Placement	5-105
5.9.5.4.2a—Shrinkage of Girder Concrete	5-105
5.9.5.4.2b—Creep of Girder Concrete	5-106
5.9.5.4.2c—Relaxation of Prestressing Strands	5-106
5.9.5.4.3—Losses: Time of Deck Placement to Final Time	5-107
5.9.5.4.3a—Shrinkage of Girder Concrete	5-107
5.9.5.4.3b—Creep of Girder Concrete	5-108
5.9.5.4.3c—Relaxation of Prestressing Strands	5-108
5.9.5.4.3d—Shrinkage of Deck Concrete	5-108
5.9.5.4.4—Precast Pretensioned Girders without Composite Topping	5-109
5.9.5.4.5—Post-Tensioned Nonsegmental Girders	5-109
5.9.5.5—Losses for Deflection Calculations	5-109
5.10—DETAILS OF REINFORCEMENT	5-110
5.10.1—Concrete Cover	5-110
5.10.2—Hooks and Bends	5-110
5.10.2.1—Standard Hooks	5-110
5.10.2.2—Seismic Hooks	5-110
5.10.2.3—Minimum Bend Diameters	5-110
5.10.3—Spacing of Reinforcement	5-111
5.10.3.1 Minimum Spacing of Reinforcing Bars	5-111
5.10.3.1.1—Cast-in-Place Concrete	5-111
5.10.3.1.2—Precast Concrete	5-111
5.10.3.1.3—Multilayers	5-111
5.10.3.1.4—Splices	5-112
5.10.3.1.5—Bundled Bars	5-112
5.10.3.2—Maximum Spacing of Reinforcing Bars	5-112
5.10.3.3—Minimum Spacing of Prestressing Tendons and Ducts	5-112
5.10.3.3.1—Pretensioning Strand	5-112
5.10.3.3.2—Post-Tensioning Ducts—Girders Straight in Plan	5-113
5.10.3.3.3—Post-Tensioning Ducts—Girders Curved in Plan	5-113
5.10.3.4—Maximum Spacing of Prestressing Tendons and Ducts in Slabs	5-113
5.10.3.5—Couplers in Post-Tensioning Tendons	5-114
5.10.4—Tendon Confinement	5-114
5.10.4.1—General	5-114
5.10.4.2—Wobble Effect in Slabs	5-114
5.10.4.3—Effects of Curved Tendons	5-114
5.10.4.3.1—Design for In-Plane Force Effects	5-115
5.10.4.3.1a—In-Plane Force Effects	5-115
5.10.4.3.1b— Shear Resistance to Pull-out	5-116
5.10.4.3.1c— Cracking of Cover Concrete	5-117
5.10.4.3.1d—Regional Bending	5-118
5.10.4.3.2—Out-of-Plane Force Effects	5-118
5.10.5—External Tendon Supports	5-119

5.10.6—Transverse Reinforcement for Compression Members	5-119
5.10.6.1—General	5-119
5.10.6.2—Spirals	5-119
5.10.6.3—Ties	5-120
5.10.7—Transverse Reinforcement for Flexural Members	5-121
5.10.8—Shrinkage and Temperature Reinforcement	5-121
5.10.9—Post-Tensioned Anchorage Zones	5-122
5.10.9.1—General	5-122
5.10.9.2—General Zone and Local Zone	5-123
5.10.9.2.1—General	5-123
5.10.9.2.2—General Zone	5-124
5.10.9.2.3—Local Zone	5-124
5.10.9.2.4—Responsibilities	5-125
5.10.9.3—Design of the General Zone	5-125
5.10.9.3.1—Design Methods	5-125
5.10.9.3.2—Design Principles	5-126
5.10.9.3.3—Special Anchorage Devices	5-129
5.10.9.3.4—Intermediate Anchorages	5-129
5.10.9.3.4a—General	5-129
5.10.9.3.4b—Tie-Backs	5-130
5.10.9.3.4c—Blister and Rib Reinforcement	5-130
5.10.9.3.5—Diaphragms	5-131
5.10.9.3.6—Multiple Slab Anchorages	5-131
5.10.9.3.7—Deviation Saddles	5-132
5.10.9.4—Application of the Strut-and-Tie Model to the Design of General Zone	5-132
5.10.9.4.1—General	5-132
5.10.9.4.2—Nodes	5-134
5.10.9.4.3—Struts	5-136
5.10.9.4.4—Ties	5-136
5.10.9.5—Elastic Stress Analysis	5-136
5.10.9.6—Approximate Stress Analyses and Design	5-137
5.10.9.6.1—Limitations of Application	5-137
5.10.9.6.2—Compressive Stresses	5-138
5.10.9.6.3—Bursting Forces	5-140
5.10.9.6.4—Edge Tension Forces	5-141
5.10.9.7—Design of Local Zones	5-142
5.10.9.7.1—Dimensions of Local Zone	5-142
5.10.9.7.2—Bearing Resistance	5-143
5.10.9.7.3—Special Anchorage Devices	5-144
5.10.10—Pretensioned Anchorage Zones	5-144
5.10.10.1—Splitting Resistance	5-144
5.10.10.2—Confinement Reinforcement	5-146
5.10.11—Provisions for Seismic Design	5-147
5.10.11.1—General	5-147
5.10.11.2—Seismic Zone 1	5-148
5.10.11.3—Seismic Zone 2	5-148

5.10.11.4—Seismic Zones 3 and 4	5-149
5.10.11.4.1—Column Requirements	5-149
5.10.11.4.1a—Longitudinal Reinforcement	5-149
5.10.11.4.1b—Flexural Resistance	5-149
5.10.11.4.1c—Column Shear and Transverse Reinforcement	5-150
5.10.11.4.1d—Transverse Reinforcement for Confinement at Plastic Hinges	5-151
5.10.11.4.1e—Spacing of Transverse Reinforcement for Confinement	5-153
5.10.11.4.1f—Splices	5-153
5.10.11.4.2—Requirements for Wall-Type Piers	5-154
5.10.11.4.3—Column Connections	5-155
5.10.11.4.4—Construction Joints in Piers and Columns	5-155
5.10.12—Reinforcement for Hollow Rectangular Compression Members	5-156
5.10.12.1—General	5-156
5.10.12.2—Spacing of Reinforcement	5-156
5.10.12.3—Ties	5-156
5.10.12.4—Splices	5-156
5.10.12.5—Hoops	5-157
5.11—DEVELOPMENT AND SPLICES OF REINFORCEMENT	5-157
5.11.1—General	5-157
5.11.1.1—Basic Requirements	5-157
5.11.1.2—Flexural Reinforcement	5-157
5.11.1.2.1—General	5-157
5.11.1.2.2—Positive Moment Reinforcement	5-158
5.11.1.2.3—Negative Moment Reinforcement	5-159
5.11.1.2.4—Moment Resisting Joints	5-159
5.11.2—Development of Reinforcement	5-160
5.11.2.1—Deformed Bars and Deformed Wire in Tension	5-160
5.11.2.1.1—Tension Development Length	5-160
5.11.2.1.2—Modification Factors which Increase ℓ_d	5-161
5.11.2.1.3—Modification Factors which Decrease ℓ_d	5-161
5.11.2.2—Deformed Bars in Compression	5-162
5.11.2.2.1—Compressive Development Length	5-162
5.11.2.2.2—Modification Factors	5-162
5.11.2.3—Bundled Bars	5-162
5.11.2.4—Standard Hooks in Tension	5-163
5.11.2.4.1—Basic Hook Development Length	5-163
5.11.2.4.2—Modification Factors	5-163
5.11.2.4.3—Hooked-Bar Tie Requirements	5-164
5.11.2.5—Welded Wire Fabric	5-164
5.11.2.5.1—Deformed Wire Fabric	5-164
5.11.2.5.2—Plain Wire Fabric	5-165
5.11.2.6—Shear Reinforcement	5-165
5.11.2.6.1—General	5-165
5.11.2.6.2—Anchorage of Deformed Reinforcement	5-166
5.11.2.6.3—Anchorage of Wire Fabric Reinforcement	5-166

5.11.2.6.4—Closed Stirrups.....	5-167
5.11.3—Development by Mechanical Anchorages.....	5-167
5.11.4—Development of Prestressing Strand.....	5-167
5.11.4.1—General.....	5-167
5.11.4.2—Bonded Strand.....	5-168
5.11.4.3—Partially Debonded Strands.....	5-169
5.11.5—Splices of Bar Reinforcement.....	5-170
5.11.5.1—Detailing.....	5-170
5.11.5.2—General Requirements.....	5-170
5.11.5.2.1—Lap Splices.....	5-170
5.11.5.2.2—Mechanical Connections.....	5-171
5.11.5.2.3—Welded Splices.....	5-171
5.11.5.3—Splices of Reinforcement in Tension.....	5-171
5.11.5.3.1—Lap Splices in Tension.....	5-171
5.11.5.3.2—Mechanical Connections or Welded Splices in Tension.....	5-172
5.11.5.4—Splices in Tension Tie Members.....	5-172
5.11.5.5—Splices of Bars in Compression.....	5-172
5.11.5.5.1—Lap Splices in Compression.....	5-172
5.11.5.5.2—Mechanical Connections or Welded Splices in Compression.....	5-173
5.11.5.5.3—End-Bearing Splices.....	5-173
5.11.6—Splices of Welded Wire Fabric.....	5-173
5.11.6.1—Splices of Welded Deformed Wire Fabric in Tension.....	5-173
5.11.6.2—Splices of Welded Smooth Wire Fabric in Tension.....	5-173
5.12—DURABILITY.....	5-174
5.12.1—General.....	5-174
5.12.2—Alkali-Silica Reactive Aggregates.....	5-175
5.12.3—Concrete Cover.....	5-175
5.12.4—Protective Coatings.....	5-176
5.12.5—Protection for Prestressing Tendons.....	5-176
5.13—SPECIFIC MEMBERS.....	5-177
5.13.1—Deck Slabs.....	5-177
5.13.2—Diaphragms, Deep Beams, Brackets, Corbels, and Beam Ledges.....	5-177
5.13.2.1—General.....	5-177
5.13.2.2—Diaphragms.....	5-177
5.13.2.3—Detailing Requirements for Deep Beams.....	5-178
5.13.2.4—Brackets and Corbels.....	5-179
5.13.2.4.1—General.....	5-179
5.13.2.4.2—Alternative to Strut-and-Tie Model.....	5-181
5.13.2.5—Beam Ledges.....	5-182
5.13.2.5.1—General.....	5-182
5.13.2.5.2—Design for Shear.....	5-183
5.13.2.5.3—Design for Flexure and Horizontal Force.....	5-184
5.13.2.5.4—Design for Punching Shear.....	5-184
5.13.2.5.5—Design of Hanger Reinforcement.....	5-185
5.13.2.5.6—Design for Bearing.....	5-186

5.13.3—Footings	5-187
5.13.3.1—General.....	5-187
5.13.3.2—Loads and Reactions.....	5-187
5.13.3.3—Resistance Factors	5-187
5.13.3.4—Moment in Footings.....	5-187
5.13.3.5—Distribution of Moment Reinforcement.....	5-188
5.13.3.6—Shear in Slabs and Footings.....	5-188
5.13.3.6.1—Critical Sections for Shear.....	5-188
5.13.3.6.2—One-Way Action.....	5-189
5.13.3.6.3—Two-Way Action.....	5-189
5.13.3.7—Development of Reinforcement.....	5-190
5.13.3.8—Transfer of Force at Base of Column.....	5-190
5.13.4—Concrete Piles	5-191
5.13.4.1—General.....	5-191
5.13.4.2—Splices.....	5-191
5.13.4.3—Precast Reinforced Piles	5-192
5.13.4.3.1—Pile Dimensions.....	5-192
5.13.4.3.2—Reinforcing Steel.....	5-192
5.13.4.4—Precast Prestressed Piles.....	5-192
5.13.4.4.1—Pile Dimensions.....	5-192
5.13.4.4.2—Concrete Quality.....	5-192
5.13.4.4.3—Reinforcement	5-193
5.13.4.5—Cast-in-Place Piles.....	5-193
5.13.4.5.1—Pile Dimensions.....	5-194
5.13.4.5.2—Reinforcing Steel.....	5-194
5.13.4.6—Seismic Requirements	5-194
5.13.4.6.1—Zone 1.....	5-194
5.13.4.6.2—Zone 2.....	5-194
5.13.4.6.2a—General.....	5-194
5.13.4.6.2b—Cast-in-Place Piles.....	5-195
5.13.4.6.2c—Precast Reinforced Piles.....	5-195
5.13.4.6.2d—Precast Prestressed Piles.....	5-195
5.13.4.6.3—Zones 3 and 4.....	5-195
5.13.4.6.3a—General.....	5-195
5.13.4.6.3b—Confinement Length.....	5-195
5.13.4.6.3c—Volumetric Ratio for Confinement.....	5-196
5.13.4.6.3d—Cast-in-Place Piles.....	5-196
5.13.4.6.3e—Precast Piles.....	5-196
5.14—PROVISIONS FOR STRUCTURE TYPES.....	5-196
5.14.1—Beams and Girders.....	5-196
5.14.1.1—General.....	5-196
5.14.1.2—Precast Beams.....	5-197
5.14.1.2.1—Preservice Conditions.....	5-197
5.14.1.2.2—Extreme Dimensions.....	5-197
5.14.1.2.3—Lifting Devices	5-197

5.14.1.2.4—Detail Design	5-197
5.14.1.2.5—Concrete Strength.....	5-198
5.14.1.3—Spliced Precast Girders	5-198
5.14.1.3.1—General.....	5-198
5.14.1.3.2—Joints between Segments	5-199
5.14.1.3.2a—General.....	5-199
5.14.1.3.2b—Details of Closure Joints.....	5-199
5.14.1.3.2c—Details of Match-Cast Joints.....	5-200
5.14.1.3.2d—Joint Design.....	5-200
5.14.1.3.3—Girder Segment Design.....	5-200
5.14.1.3.4—Post-Tensioning	5-201
5.14.1.4—Bridges Composed of Simple Span Precast Girders Made Continuous.....	5-201
5.14.1.4.1—General.....	5-201
5.14.1.4.2—Restraint Moments.....	5-202
5.14.1.4.3—Material Properties.....	5-203
5.14.1.4.4—Age of Girder When Continuity Is Established	5-203
5.14.1.4.5—Degree of Continuity at Various Limit States.....	5-204
5.14.1.4.6—Service Limit State.....	5-205
5.14.1.4.7—Strength Limit State	5-206
5.14.1.4.8—Negative Moment Connections.....	5-206
5.14.1.4.9—Positive Moment Connections	5-206
5.14.1.4.9a—General.....	5-206
5.14.1.4.9b—Positive Moment Connection Using Mild Reinforcement.....	5-207
5.14.1.4.9c—Positive Moment Connection Using Prestressing Strand.....	5-208
5.14.1.4.9d—Details of Positive Moment Connection	5-208
5.14.1.4.10—Continuity Diaphragms.....	5-209
5.14.1.5—Cast-in-Place Girders and Box and T-Beams	5-210
5.14.1.5.1—Flange and Web Thickness	5-210
5.14.1.5.1a—Top Flange	5-210
5.14.1.5.1b—Bottom Flange	5-210
5.14.1.5.1c—Web.....	5-210
5.14.1.5.2—Reinforcement.....	5-210
5.14.1.5.2a—Deck Slab Reinforcement Cast-in-Place in T-Beams and Box Girders.....	5-210
5.14.1.5.2b—Bottom Slab Reinforcement in Cast-in-Place Box Girders.....	5-211
5.14.2—Segmental Construction	5-211
5.14.2.1—General.....	5-211
5.14.2.2—Analysis of Segmental Bridges.....	5-212
5.14.2.2.1—General.....	5-212
5.14.2.2.2—Construction Analysis.....	5-212
5.14.2.2.3—Analysis of the Final Structural System.....	5-212
5.14.2.3—Design.....	5-213
5.14.2.3.1—Loads.....	5-213
5.14.2.3.2—Construction Loads.....	5-213
5.14.2.3.3—Construction Load Combinations at the Service Limit State.....	5-214
5.14.2.3.4—Construction Load Combinations at Strength Limit States.....	5-217
5.14.2.3.4a—Superstructures.....	5-217

5.14.2.3.4b—Substructures	5-217
5.14.2.3.5—Thermal Effects During Construction.....	5-217
5.14.2.3.6—Creep and Shrinkage.....	5-217
5.14.2.3.7—Prestress Losses	5-218
5.14.2.3.8—Provisional Post-Tensioning Ducts and Anchorages	5-219
5.14.2.3.8a—General.....	5-219
5.14.2.3.8b—Bridges with Internal Ducts.....	5-219
5.14.2.3.8c—Provision for Future Dead Load or Deflection Adjustment.....	5-219
5.14.2.3.9—Plan Presentation	5-219
5.14.2.3.10—Box Girder Cross-Section Dimensions and Details.....	5-220
5.14.2.3.10a—Minimum Flange Thickness	5-220
5.14.2.3.10b—Minimum Web Thickness	5-220
5.14.2.3.10c—Length of Top Flange Cantilever.....	5-221
5.14.2.3.10d—Overall Cross-Section Dimensions.....	5-221
5.14.2.3.10e—Overlays.....	5-222
5.14.2.3.11—Seismic Design	5-222
5.14.2.4—Types of Segmental Bridges.....	5-223
5.14.2.4.1—General	5-223
5.14.2.4.2—Details for Precast Construction	5-223
5.14.2.4.3—Details for Cast-in-Place Construction	5-225
5.14.2.4.4—Cantilever Construction.....	5-225
5.14.2.4.5—Span-by-Span Construction.....	5-225
5.14.2.4.6—Incrementally Launched Construction.....	5-226
5.14.2.4.6a—General.....	5-226
5.14.2.4.6b—Force Effects Due to Construction Tolerances.....	5-226
5.14.2.4.6c—Design Details.....	5-227
5.14.2.4.6d—Design of Construction Equipment	5-228
5.14.2.5—Use of Alternative Construction Methods	5-228
5.14.2.6—Segmentally Constructed Bridge Substructures.....	5-230
5.14.2.6.1—General	5-230
5.14.2.6.2—Construction Load Combinations.....	5-230
5.14.2.6.3—Longitudinal Reinforcement of Hollow, Rectangular Precast Segmental Piers	5-230
5.14.3—Arches	5-231
5.14.3.1—General.....	5-231
5.14.3.2—Arch Ribs.....	5-231
5.14.4—Slab Superstructures	5-231
5.14.4.1—Cast-in-Place Solid Slab Superstructures.....	5-231
5.14.4.2—Cast-in-Place Voids Slab Superstructures	5-232
5.14.4.2.1—Cross-Section Dimensions.....	5-232
5.14.4.2.2—Minimum Number of Bearings.....	5-233
5.14.4.2.3—Solid End Sections.....	5-233
5.14.4.2.4—General Design Requirements	5-233
5.14.4.2.5—Compressive Zones in Negative Moment Area.....	5-234
5.14.4.2.6—Drainage of Voids.....	5-234
5.14.4.3—Precast Deck Bridges.....	5-234
5.14.4.3.1—General	5-234

5.14.4.3.2—Shear Transfer Joints.....	5-235
5.14.4.3.3—Shear-Flexure Transfer Joints.....	5-235
5.14.4.3.3a—General.....	5-235
5.14.4.3.3b—Design.....	5-235
5.14.4.3.3c—Post-Tensioning.....	5-235
5.14.4.3.3d—Longitudinal Construction Joints.....	5-235
5.14.4.3.3e—Cast-in-Place Closure Joint.....	5-236
5.14.4.3.3f—Structural Overlay.....	5-236
5.14.5—Additional Provisions for Culverts.....	5-236
5.14.5.1—General.....	5-236
5.14.5.2—Design for Flexure.....	5-236
5.14.5.3—Design for Shear in Slabs of Box Culverts.....	5-236
5.15—REFERENCES.....	5-237
APPENDIX A5—BASIC STEPS FOR CONCRETE BRIDGES.....	5-247
A5.1—GENERAL.....	5-247
A5.2—GENERAL CONSIDERATIONS.....	5-247
A5.3—BEAM AND GIRDER SUPERSTRUCTURE DESIGN.....	5-247
A5.4—SLAB BRIDGES.....	5-248
A5.5—SUBSTRUCTURE DESIGN.....	5-249
APPENDIX B5—GENERAL PROCEDURE FOR SHEAR DESIGN WITH TABLES.....	5-251
B5.1—BACKGROUND.....	5-251
B5.2—SECTIONAL DESIGN MODEL—GENERAL PROCEDURE.....	5-251
APPENDIX C5—UPPER LIMITS FOR ARTICLES AFFECTED BY CONCRETE COMPRESSIVE STRENGTH.....	5-259

CONCRETE STRUCTURES

5.1—SCOPE

The provisions in this section apply to the design of bridge and retaining wall components constructed of normal weight or lightweight concrete and reinforced with steel bars, welded wire reinforcement, and/or prestressing strands, bars, or wires. The provisions are based on concrete strengths varying from 2.4 ksi to 10.0 ksi, except where higher strengths are allowed for normal weight concrete.

The provisions of this section combine and unify the requirements for reinforced, prestressed, and partially prestressed concrete. Provisions for seismic design, analysis by the strut-and-tie model, and design of segmentally constructed concrete bridges and bridges made from precast concrete elements have been added.

A brief outline for the design of some routine concrete components is contained in Appendix A.

5.2—DEFINITIONS

Anchorage—In post-tensioning, a mechanical device used to anchor the tendon to the concrete; in pretensioning, a device used to anchor the tendon until the concrete has reached a predetermined strength, and the prestressing force has been transferred to the concrete; for reinforcing bars, a length of reinforcement, or a mechanical anchor or hook, or combination thereof at the end of a bar needed to transfer the force carried by the bar into the concrete.

Anchorage Blister—A build-out area in the web, flange, or flange-web junction for the incorporation of tendon anchorage fittings.

Anchorage Zone—The portion of the structure in which the prestressing force is transferred from the anchorage device onto the local zone of the concrete, and then distributed more widely into the general zone of the structure.

At Jacking—At the time of tensioning, the prestressing tendons.

At Loading—The maturity of the concrete when loads are applied. Such loads include prestressing forces and permanent loads but generally not live loads.

At Transfer—Immediately after the transfer of prestressing force to the concrete.

Blanketed Strand—See *Partially Debonded Strand*.

Bonded Tendon—A tendon that is bonded to the concrete, either directly or by means of grouting.

Bursting Force—Tensile forces in the concrete in the vicinity of the transfer or anchorage of prestressing forces.

Cast-in-Place Concrete—Concrete placed in its final location in the structure while still in a plastic state.

Closely Spaced Anchorages—Anchorage devices are defined as closely spaced if their center-to-center spacing does not exceed 1.5 times the width of the anchorage devices in the direction considered.

Closure—A placement of cast-in-place concrete used to connect two or more previously cast portions of a structure.

Composite Construction—Concrete components or concrete and steel components interconnected to respond to force effects as a unit.

Compression-Controlled Section—A cross-section in which the net tensile strain in the extreme tension steel at nominal resistance is less than or equal to the compression-controlled strain limit.

Compression-Controlled Strain Limit—The net tensile strain in the extreme tension steel at balanced strain conditions. See Article 5.7.2.1.

Concrete Cover—The specified minimum distance between the surface of the reinforcing bars, strands, post-tensioning ducts, anchorages, or other embedded items, and the surface of the concrete.

Confinement—A condition where the disintegration of the concrete under compression is prevented by the development of lateral and/or circumferential forces such as may be provided by appropriate reinforcing, steel or composite tubes, or similar devices.

Confinement Anchorage—Anchorage for a post-tensioning tendon that functions on the basis of containment of the concrete in the local anchorage zone by special reinforcement.

Creep—Time-dependent deformation of concrete under permanent load.

Curvature Friction—Friction resulting from the tendon moving against the duct when tensioned due to the curvature of the duct.

Deck Slab—A solid concrete slab resisting and distributing wheel loads to the supporting components.

Decompression—The stage at which the compressive stresses, induced by prestress, are overcome by the tensile stresses.

Deep Component—Components in which the distance from the point of 0.0 shear to the face of the support is less than $2d$ or components in which a load causing more than one-third of the shear at a support is closer than $2d$ from the face of the support.

Deviation Saddle—A concrete block build-out in a web, flange, or web-flange junction used to control the geometry of, or to provide a means for changing direction of, external tendons.

Development Length—The distance required to develop the specified strength of a reinforcing bar or prestressing strand.

Direct Loading/Supporting—Application of a load or use of a support external to the member, as in the case of point or uniform loads applied directly to the deck surface, simply-supported girder ends, bent (pier) cap supported on pinned columns.

Duct Stack—A vertical group of tendons in which the space between individual tendons is less than 1.5 in.

Edge Distance—The minimum distance between the centerline of reinforcement or other embedded elements and the edge of the concrete.

Effective Depth—The depth of a component effective in resisting flexural or shear forces.

Effective Prestress—The stress or force remaining in the prestressing steel after all losses have occurred.

Embedment Length—The length of reinforcement or anchor provided beyond a critical section over which transfer of force between concrete and reinforcement may occur.

External Tendon—A post-tensioning tendon placed outside of the body of concrete, usually inside a box girder.

Extreme Tension Steel—The reinforcement (prestressed or nonprestressed) that is farthest from the extreme compression fiber.

Fully Prestressed Component—Prestressed concrete component in which stresses satisfy the tensile stress limits at Service Limit State specified herein. Such components are assumed to remain uncracked at the Service Limit State.

General Zone—Region adjacent to a post-tensioned anchorage within which the prestressing force spreads out to an essentially linear stress distribution over the cross-section of the component.

Intermediate Anchorage—Anchorage not located at the end surface of a member or segment for tendons that do not extend over the entire length of the member or segment; usually in the form of embedded anchors, blisters, ribs, or recess pockets.

Indirect Loading/Supporting—Application of a load or use of a support internally such as girders framing into an integral bent (pier) cap, dapped or spliced-girders where load transfer is between the top and bottom face of the member, or utility loads hung from the web of a girder.

Internal Tendon—A post-tensioning tendon placed within the body of concrete.

Isotropic Reinforcement—An arrangement of reinforcement in which the bars are orthogonal, and the reinforcement ratios in the two directions are equal.

Jacking Force—The force exerted by the device that introduces tension into the tendons.

Launching Bearing—Temporary bearings with low friction characteristics used for construction of bridges by the incremental launching method.

Launching Nose—Temporary steel assembly attached to the front of an incrementally launched bridge to reduce superstructure force effects during launching.

Lightweight Concrete—Concrete containing lightweight aggregate and having an air-dry unit weight not exceeding 0.120 kcf, as determined by ASTM C567. Lightweight concrete without natural sand is termed “all-lightweight concrete” and lightweight concrete in which all of the fine aggregate consists of normal weight sand is termed “sand-lightweight concrete.”

Local Bending—The lateral flexural bending caused by curved post-tensioning tendons on the concrete cover between the internal ducts and the inside face of the curved element (usually webs).

Local Shear—The lateral shear caused by curved post-tensioning tendons on the concrete cover between the internal ducts and the inside face of the curved element (usually webs).

Local Zone—The volume of concrete that surrounds and is immediately ahead of the anchorage device and that is subjected to high compressive stresses.

Low Relaxation Steel—Prestressing strand in which the steel relaxation losses have been substantially reduced by stretching at an elevated temperature.

Net Tensile Strain—The tensile strain at nominal resistance exclusive of strains due to effective prestress, creep, shrinkage, and temperature.

Normal Weight Concrete—Concrete having a weight between 0.135 and 0.155 kcf.

Partially Debonded Strand—A pretensioned prestressing strand that is bonded for a portion of its length and intentionally debonded elsewhere through the use of mechanical or chemical means. Also called shielded or blanketed strand.

Post-Tensioning—A method of prestressing in which the tendons are tensioned after the concrete has reached a predetermined strength.

Post-Tensioning Duct—A form device used to provide a path for post-tensioning tendons or bars in hardened concrete. The following types are in general use:

Rigid Duct—Seamless tubing stiff enough to limit the deflection of a 20.0-ft length supported at its ends to not more than 1.0 in.

Semirigid Duct—A corrugated duct of metal or plastic sufficiently stiff to be regarded as not coilable into conventional shipping coils without damage.

Flexible Duct—A loosely interlocked duct that can be coiled into a 4.0-ft diameter without damage.

Precast Members—Concrete elements cast in a location other than their final position.

Precompressed Tensile Zone—Any region of a prestressed component in which prestressing causes compressive stresses and service load effects cause tensile stresses.

Prestressed Concrete—Concrete components in which stresses and deformations are introduced by application of prestressing forces.

Pretensioning—A method of prestressing in which the strands are tensioned before the concrete is placed.

Regional Bending—Transverse bending of a concrete box girder web due to concentrated lateral prestress forces resisted by the frame action of the box acting as a whole.

Reinforced Concrete—Structural concrete containing no less than the minimum amounts of prestressing tendons or nonprestressed reinforcement specified herein.

Reinforcement—Reinforcing bars and/or prestressing steel.

Relaxation—The time-dependent reduction of stress in prestressing tendons.

Resal Effect—The reduction or addition of shear based on the bottom slab compression angle with the center of gravity.

Segmental Construction—The fabrication and erection of a structural element (superstructure and/or substructure) using individual elements, which may be either precast or cast-in-place. The completed structural element acts as a monolithic unit under some or all design loads. Post-tensioning is typically used to connect the individual elements. For superstructures, the individual elements are typically short (with respect to the span length), box-shaped segments with monolithic flanges that comprise the full width of the structure. (See Article 5.14.2.)

Seismic Hoop—A cylindrical noncontinuously wound tie with closure made using a butt weld or a mechanical coupler.

Shielded Strand—See *Partially Debonded Strand*.

Slab—A component having a width of at least four times its effective depth.

Special Anchorage Device—Anchorage device whose adequacy should be proven in a standardized acceptance test. Most multiplane anchorages and all bond anchorages are special anchorage devices.

Specified Strength of Concrete—The nominal compressive strength of concrete specified for the work and assumed for design and analysis of new structures.

Spiral—Continuously wound bar or wire in the form of a cylindrical helix.

Spliced Precast Girder—A type of superstructure in which precast concrete beam-type elements are joined longitudinally, typically using post-tensioning, to form the completed girder. The bridge cross-section is typically a conventional structure consisting of multiple precast girders. This type of construction is not considered to be segmental construction for the purposes of these Specifications. (See Article 5.14.1.3.)

Splitting Tensile Strength—The tensile strength of concrete that is determined by a splitting test made in accordance with AASHTO T 198 (ASTM C496).

Stress Range—The algebraic difference between the maximum and minimum stresses due to transient loads.

Structural Concrete—All concrete used for structural purposes.

Structural Mass Concrete—Any large volume of concrete where special materials or procedures are required to cope with the generation of heat of hydration and attendant volume change to minimize cracking.

Strut-and-Tie Model—A model used principally in regions of concentrated forces and geometric discontinuities to determine concrete proportions and reinforcement quantities and patterns based on assumed compression struts in the concrete, tensile ties in the reinforcement, and the geometry of nodes at their points of intersection.

Temperature Gradient—Variation of temperature of the concrete over the cross-section.

Tendon—A high-strength steel element used to prestress the concrete.

Tension-Controlled Section—A cross-section in which the net tensile strain in the extreme tension steel at nominal resistance is greater than or equal to 0.005.

Transfer—The operation of imparting the force in a pretensioning anchoring device to the concrete.

Transfer Length—The length over which the pretensioning force is transferred to the concrete by bond and friction in a pretensioned member.

Transverse Reinforcement—Reinforcement used to resist shear, torsion, and lateral forces or to confine concrete in a structural member. The terms “stirrups” and “web reinforcement” are usually applied to transverse reinforcement in flexural members and the terms “ties,” “hoops,” and “spirals” are applied to transverse reinforcement in compression members.

Wobble Friction—The friction caused by the deviation of a tendon duct or sheath from its specified profile.

Yield Strength—The specified yield strength of reinforcement.

5.3—NOTATION

A	=	the maximum area of the portion of the supporting surface that is similar to the loaded area and concentric with it and that does not overlap similar areas for adjacent anchorage devices (in. ²); for segmental construction: static weight of precast segment being handled (kip) (5.10.9.7.2) (5.14.2.3.2)
A_b	=	area of an individual bar (in. ²); effective bearing area (in. ²); net area of a bearing plate (in. ²) (5.10.9.6.2) (5.10.9.7.2)
A_c	=	area of core of spirally reinforced compression member measured to the outside diameter of the spiral (in. ²); gross area of concrete deck slab (in. ²) (5.7.4.6) (C5.14.1.4.3)
A_{cb}	=	the area of the continuing cross-section within the extensions of the sides of the anchor plate or blister, i.e., the area of the blister or rib shall not be taken as part of the cross-section (in. ²) (5.10.9.3.4b)
A_{cp}	=	area enclosed by outside perimeter of concrete cross-section, including area of holes, if any (in. ²) (5.8.2.1) (5.8.6.3)
A_{cs}	=	cross-sectional area of a concrete strut in strut-and-tie model (in. ²) (5.6.3.3.1)
A_{cv}	=	area of concrete section resisting shear transfer (in. ²) (5.8.4.1)
A_d	=	area of deck concrete (in. ²) (5.9.5.4.3d)
A_g	=	gross area of section (in. ²); gross area of bearing plate (in. ²) (5.5.4.2.1) (5.10.9.7.2)
A_h	=	area of shear reinforcement parallel to flexural tension reinforcement (in. ²) (5.13.2.4.1)
A_{hr}	=	area of one leg of hanger reinforcement in beam ledges and inverted T-beams (in. ²) (5.13.2.5.5)
AI	=	for segmental construction: dynamic response due to accidental release or application of a precast segment (kip) (5.14.2.3.2)
A_t	=	area of longitudinal torsion reinforcement in the exterior web of the box girder (in. ²); area of longitudinal column reinforcement (in. ²) (5.8.3.6.3) (5.11.5.2.1)
A_n	=	area of reinforcement in bracket or corbel resisting tensile force N_{uc} (in. ²) (5.13.2.4.2)
A_o	=	area enclosed by shear flow path, including area of holes, if any (in. ²) (5.8.2.1)
A_{oh}	=	area enclosed by centerline of exterior closed transverse torsion reinforcement, including area of holes, if any (in. ²) (5.8.2.1)
A_{ps}	=	area of prestressing steel (in. ²); area of prestressing steel (in. ²) (5.5.4.2.1) (5.7.4.4)
A_{psb}	=	area of bonded prestressing steel (in. ²) (5.7.3.1.3b)
A_{psu}	=	area of unbonded prestressing steel (in. ²) (5.7.3.1.3b)

A_s	=	area of nonprestressed tension reinforcement (in. ²); total area of longitudinal deck reinforcement (in. ²) (5.5.4.2.1) (C5.14.1.4.3)
A'_s	=	area of compression reinforcement (in. ²) (5.7.3.1.1)
A_{sh}	=	cross-sectional area of column tie reinforcements (in. ²) (5.10.11.4.1d)
A_{sk}	=	area of skin reinforcement per unit height in one side face (in. ²) (5.7.3.4)
A_{sp}	=	area of shaft spiral or transverse reinforcement (in. ²) (5.11.5.2.1)
A_{sp1}	=	cross-sectional area of a tendon in the larger group (in. ²) (C5.9.5.2.3b)
A_{sp2}	=	cross-sectional area of a tendon in the smaller group (in. ²) (C5.9.5.2.3b)
A_{ss}	=	area of reinforcement in an assumed strut of a strut-and-tie model (in. ²) (5.6.3.3.4)
A_{st}	=	total area of longitudinal mild steel reinforcement (in. ²) (5.6.3.4.1)
A_{s-BW}	=	area of steel in the footing band width (in. ²) (5.13.3.5)
A_{s-SD}	=	total area of steel in short direction of a footing (in. ²) (5.13.3.5)
A_t	=	area of one leg of closed transverse torsion reinforcement (in. ²) (5.8.3.6.2)
A_{tr}	=	area of concrete deck slab with transformed longitudinal deck reinforcement (in. ²) (C5.14.1.4.3)
A_v	=	area of a transverse reinforcement within distance s (in. ²) (5.8.2.5)
A_{vf}	=	area of shear-friction reinforcement (in. ²); area of reinforcement for interface shear between concretes of slab and beam (in. ² /in.); total area of reinforcement, including flexural reinforcement (in. ²) (5.8.4.1) (5.10.11.4.4)
A_w	=	area of an individual wire to be developed or spliced (in. ²) (5.11.2.5.1)
A_1	=	loaded area (in. ²) (5.7.5)
A_2	=	area of the lower base of the largest frustum of a pyramid, cone, or tapered wedge contained wholly within the support and having for its upper base the loaded area and having side slopes of 1 vertical to 2 horizontal (in. ²) (5.7.5)
a	=	depth of equivalent rectangular stress block (in.); the anchor plate width (in.); the lateral dimension of the anchorage device measured parallel to the larger dimension of the cross-section (in.) (5.7.2.2) (5.10.9.3.6) (5.10.9.6.1)
a_{eff}	=	lateral dimension of the effective bearing area measured parallel to the larger dimension of the cross-section (in.) (5.10.9.6.2)
a_f	=	distance between concentrated load and reinforcement parallel to load (in.) (5.13.2.5.1)
a_v	=	shear span: distance between concentrated load and face of support (in.) (5.13.2.4.1)
b	=	for rectangular sections, the width of the compression face of the member; for a flange section in compression, the effective width of the flange as specified in Article 4.6.2.6 (in.); least width of component section (in.); the lateral dimension of the anchorage device measured parallel to the smaller dimension of the cross-section (in.) (5.7.3) (5.10.8) (5.10.9.6.2)
b_e	=	effective width of the shear flow path (in.) (5.8.6.3)
b_{eff}	=	lateral dimension of the effective bearing area measured parallel to the smaller dimension of the cross-section (in.) (5.10.9.6.2)
b_o	=	perimeter of critical section for slabs and footings (in.) (5.13.3.6.1)
b_v	=	width of web adjusted for the presence of ducts (in.); width of the interface (in.) (5.8.2.9) (5.8.4.1)
b_w	=	width of member's web (in.); web width or diameter of a circular section (in.) (5.6.3.6) (5.7.3.1.1)
CEQ	=	for segmental construction: specialized construction equipment (kip) (5.14.2.3.2)
CLE	=	for segmental construction: longitudinal construction equipment load (kip) (5.14.2.3.2)
CLL	=	for segmental construction: distributed construction live load (ksf) (5.14.2.3.2)
CR	=	loss of prestress due to creep of concrete (ksi) (5.14.2.3.2)
c	=	distance from the extreme compression fiber to the neutral axis (in.); cohesion factor (ksi); required concrete cover over the reinforcing steel (in.); spacing from centerline of bearing to end of beam (in.) (5.5.4.2.1) (5.7.2.2) (5.8.4.1) (C5.10.9.7.1) (5.13.2.5.2)
D	=	external diameter of the circular member (in.) (C5.8.2.9)
DC	=	weight of supported structure (kip) (5.14.2.3.2)
$DIFF$	=	for segmental construction: differential load (kip) (5.14.2.3.2)
D_r	=	diameter of the circle passing through the centers of the longitudinal reinforcement (in.) (C5.8.2.9)
DW	=	superimposed dead load (kip) or (klf) (5.14.2.3.2)
d	=	distance from compression face to centroid of tension reinforcement (in.) (5.7.3.4)
d_b	=	nominal diameter of a reinforcing bar, wire, or prestressing strand (in.) (5.10.2.1)
d_{burst}	=	distance from anchorage device to the centroid of the bursting force, T_{burst} (in.) (5.10.9.3.2)
d_c	=	thickness of concrete cover measured from extreme tension fiber to center of bar or wire located closest thereto (in.); minimum concrete cover over the tendon duct, plus one-half of the duct diameter (in.) (5.7.3.4) (5.10.4.3.1)
d_e	=	effective depth from extreme compression fiber to the centroid of the tensile force in the tensile reinforcement (in.) (5.8.2.9)

d_f	=	distance from top of ledge to compression reinforcement (in.) (5.13.2.5.5)
d_t	=	distance from the extreme compression fiber to the centroid of extreme tension steel element (in.) (5.7.3.4)
d_p	=	distance from extreme compression fiber to the centroid of the prestressing tendons (in.) (5.7.3.1.1)
d_s	=	distance from extreme compression fiber to the centroid of the nonprestressed tensile reinforcement (in.) (5.7.3.2.2)
d'_s	=	distance from extreme compression fiber to the centroid of compression reinforcement (in.) (5.7.3.2.2)
d_t	=	distance from extreme compression fiber to centroid of extreme tension steel (in.) (5.5.4.2.1)
d_v	=	effective shear depth (in.) (5.8.2.9)
d_{eff}	=	one-half the effective length of the failure plane in shear and tension for curved element (in.) (5.10.4.3.1)
d_{duct}	=	outside diameter of post-tensioning duct (in.) (5.10.4.3.1)
E_b	=	modulus of elasticity of the bearing plate material (ksi) (5.10.9.7.2)
E_c	=	modulus of elasticity of concrete (ksi) (5.4.2.4)
E_{cd}	=	modulus of elasticity of deck concrete (ksi) (5.9.5.4.3d)
$E_{c\ deck}$	=	modulus of elasticity of deck concrete (ksi) (C5.14.1.4.3)
E_{ci}	=	modulus of elasticity of concrete at transfer (ksi) (C5.9.5.2.3a)
E_{ct}	=	modulus of elasticity of concrete at transfer or time of load application (ksi) (5.9.5.2.3a)
E_{eff}	=	effective modulus of elasticity (ksi) (C5.14.2.3.6)
EI	=	flexural stiffness (kip-in. ²) (5.7.4.3)
E_p	=	modulus of elasticity of prestressing tendons (ksi) (5.4.4.2) (5.7.4.4)
E_s	=	modulus of elasticity of reinforcing bars (ksi) (5.4.3.2)
e	=	base of Napierian logarithms; eccentricity of the anchorage device or group of devices with respect to the centroid of the cross-section; always taken as positive (in.); minimum edge distance for anchorage devices as specified by the supplier (in.) (5.9.2) (5.10.9.6.3) (C5.10.9.7.1)
e_d	=	eccentricity of deck with respect to the transformed composite section, taken as negative in common construction (in.) (5.9.5.4.3d)
e_m	=	average eccentricity at midspan (in.) (C5.9.5.2.3a)
e_{pc}	=	eccentricity of strands with respect to centroid of composite section (in.) (5.9.5.4.3a)
e_{pg}	=	eccentricity of strands with respect to centroid of girder (in.) (5.9.5.4.2a)
F	=	force effect calculated using instantaneous modulus of elasticity at time loading is applied (kip) (5.9.2)
F'	=	reduced force resultant accounting for creep in time corresponding to the ϕ used (kip) (5.9.2)
F_ε	=	reduction factor (5.8.3.4.2)
F_{u-in}	=	in-plane deviation force effect per unit length of tendon (kips/ft) (5.10.4.3.1)
F_{u-out}	=	out-of-plane force effect per unit length of tendon (kips/ft) (5.10.4.3.2)
f_b	=	stress in anchor plate at a section taken at the edge of the wedge hole or holes (ksi) (5.10.9.7.2)
f'_c	=	specified compressive strength of concrete for use in design (ksi) (5.4.2.1)
f_{ca}	=	concrete compressive stress ahead of the anchorage devices (ksi) (5.10.9.6.2)
f_{cb}	=	unfactored dead load compressive stress in the region behind the anchor (ksi) (5.10.9.3.4b)
f_{cgp}	=	concrete stress at the center of gravity of prestressing tendons, that results from the prestressing force at either transfer or jacking and the self-weight of the member at sections of maximum moment (ksi) (5.9.5.2.3a)
f'_{ci}	=	specified compressive strength of concrete at time of initial loading or prestressing (ksi); nominal concrete strength at time of application of tendon force (ksi) (5.4.2.3.2) (5.10.9.7.2)
f_{cpe}	=	compressive stress in concrete due to effective prestress forces only (after allowance for all prestress losses) at extreme fiber of section where tensile stress is caused by externally applied loads (ksi) (5.7.3.3.2)
f_{cr}	=	design flexural cracking stress of the hypothetical unreinforced concrete beam consisting of the cover concrete over the inside face of a stack of horizontally curved post-tensioned tendons (ksi) (5.10.4.3.1)
f_{ct}	=	average splitting tensile strength of lightweight aggregate concrete (ksi) (5.8.2.2)
f_{cu}	=	limiting concrete compressive stress for design by strut-and-tie model (ksi) (5.6.3.3.1)
f_{min}	=	algebraic minimum stress level (ksi) (5.5.3.2)
f_n	=	nominal concrete bearing stress (ksi) (5.10.9.7.2)
f_{pbt}	=	stress in prestressing steel immediately prior to transfer (ksi) (C5.9.5.2.3a)
f_{pc}	=	compressive stress in concrete after all prestress losses have occurred either at the centroid of the cross-section resisting live load or at the junction of the web and flange when the centroid lies in the flange (ksi); in a composite section, f_{pc} is the resultant compressive stress at the centroid of the composite section or at the junction of the web and flange when the centroid lies within the flange, that results from both prestress and the bending moments resisted by the precast member acting alone (ksi) (C5.6.3.5)

f_{pe}	=	effective stress in the prestressing steel after losses (ksi) (5.6.3.4.1) (5.7.4.4)
f_{pj}	=	stress in the prestressing steel at jacking (ksi) (5.9.3)
f_{po}	=	a parameter taken as modulus of elasticity of prestressing tendons multiplied by the locked-in difference in strain between the prestressing tendons and the surrounding concrete (ksi) (5.8.3.4.2)
f_{ps}	=	average stress in prestressing steel at the time for which the nominal resistance of member is required (ksi) (C5.6.3.3.3)
f_{psl}	=	stress in the strand at the Service limit state. Cracked section shall be assumed (ksi) (C5.14.1.4.9)
f_{pt}	=	stress in prestressing steel immediately after transfer (ksi) (5.9.3)
f_{pu}	=	specified tensile strength of prestressing steel (ksi) (5.4.4.1)
f_{pul}	=	stress in the strand at the Strength limit state (ksi) (C5.14.1.4.9)
f_{px}	=	design stress in pretensioned strand at nominal flexural strength at section of member under consideration (ksi) (C5.11.4.2)
f_{py}	=	yield strength of prestressing steel (ksi) (5.4.4.1)
f_r	=	modulus of rupture of concrete (ksi) (5.4.2.6)
f_s	=	stress in the mild tension reinforcement at nominal flexural resistance (ksi) (5.7.3.1) (5.7.3.2)
f'_s	=	stress in the mild steel compression reinforcement at nominal flexural resistance (ksi) (5.7.3.1) (5.7.3.2)
f_{ss}	=	tensile stress in mild steel reinforcement at the service limit state (ksi) (5.7.3.4)
f_{ut}	=	specified minimum tensile strength of column longitudinal reinforcement (ksi), 90 ksi for ASTM A615 and 80 ksi for ASTM A706 (5.11.5.2.1)
f_y	=	specified minimum yield strength of reinforcing bars (ksi); specified yield strength of reinforcing bars ≤ 75 ksi (5.5.4.2.1) (5.10.8)
f_{ytr}	=	specified minimum yield strength of shaft transverse reinforcement (ksi) (5.11.5.2.1)
f'_y	=	specified minimum yield strength of compression reinforcement (ksi) (5.7.3.1.1)
f_{yh}	=	specified yield strength of transverse reinforcement (ksi) (5.7.4.6)
H	=	average annual ambient mean relative humidity (percent) (5.4.2.3.2)
h	=	overall thickness or depth of a member (in.); least thickness of component section (in.); lateral dimension of the cross-section in the direction considered (in.) (5.7.3.4) (5.10.8) (5.10.9.6.3)
h_c	=	core dimension of tied column in direction under consideration (in.) (5.10.11.4.1d)
h_c	=	clear span of the web of concrete box girder bridges between the top and bottom slabs measured along the axis of the webs (in.) (C5.10.4.3.1)
h_{ds}	=	height of a vertical group of ducts (in.) (C5.10.4.3.1)
h_f	=	compression flange depth (in.) (5.7.3.1.1)
h_1	=	largest lateral dimension of member (in.) (C5.10.9.3.2)
h_2	=	least lateral dimension of member (in.) (C5.10.9.3.2)
I_c	=	moment of inertia of section calculated using the net concrete section properties of the girder and the deck and the deck-to-girder modular ratio at service (in. ⁴) (5.9.5.4.3a)
I_{cr}	=	moment of inertia of the cracked section, transformed to concrete (in. ⁴) (5.7.3.6.2)
IE	=	for segmental construction: dynamic load from equipment (kip) (5.14.2.3.2)
I_e	=	effective moment of inertia (in. ⁴) (5.7.3.6.2)
I_g	=	moment of inertia of the gross concrete section about the centroidal axis, neglecting the reinforcement (in. ⁴) (5.7.3.6.2)
I_s	=	moment of inertia of the reinforcing taken about the centroid of the column (in. ⁴) (5.7.4.3)
K	=	effective length factor for compression members; stress variable used in calculating torsional cracking moment; wobble friction coefficient (per ft of tendon) (5.7.4.1) (5.8.6.3) (5.9.5.2.2b)
K_{df}	=	transformed section coefficient that accounts for time-dependent interaction between concrete and bonded steel in the section being considered for time period between deck placement and final time (5.9.5.4.3a)
K_{id}	=	transformed section coefficient that accounts for time-dependent interaction between concrete and bonded steel in the section being considered for time period between transfer and deck placement (5.9.5.4.2a)
K_L	=	factor accounting for type of steel taken as 30 for low relaxation strands and 7 for other prestressing steel, unless more accurate manufacturer's data are available (5.9.5.4.2c)
K'_L	=	factor accounting for type of steel (C5.9.5.4.2c)
K_1	=	correction factor for source of aggregate (5.4.2.4)
k	=	factor representing the ratio of column tensile reinforcement to total column reinforcement at the nominal resistance (5.11.5.2.1)
k_c	=	factor for the effect of the volume-to-surface ratio (C5.4.2.3.2)
k_f	=	factor for the effect of concrete strength (5.4.2.3.2)
k_{hc}	=	humidity factor for creep (5.4.2.3.2)

k_{hs}	=	humidity factor for shrinkage (5.4.2.3.3)
k_s	=	factor for the effect of the volume-to-surface ratio (C5.4.2.3.2)
k_{td}	=	time development factor (5.4.2.3.2)
k_{vs}	=	factor for the effect of the volume-to-surface ratio of the component (5.4.2.3.2)
L	=	span length (ft or in.); length of bearing plate or pad (in.) (5.7.3.1.2) (5.13.2.5.4)
ℓ_a	=	additional embedment length at support or at point of inflection (in.) (C5.11.1.2.2)
ℓ_c	=	longitudinal extent of confining reinforcement of the local zone but not more than the larger of 1.15 a_{eff} or 1.15 b_{eff} (in.); length of lap for compression lap splices (in.) (5.10.9.6.2) (5.11.5.5.1)
ℓ_d	=	development length (in.) (5.11.1.2.1)
ℓ_{db}	=	basic development length for straight reinforcement to which modification factors are applied to determine ℓ_d (in.) (5.11.2.1.1)
ℓ_{dh}	=	development length of standard hook in tension as measured from critical section to outside end of hook (in.) (5.11.2.4.1)
ℓ_{dsh}	=	total length of extended strand (in.) (C5.14.1.4.9)
ℓ_e	=	effective tendon length (in.); embedment length beyond standard stirrup hook (in.) (5.7.3.1.2) (5.11.2.6.2)
ℓ_{hb}	=	basic development length of standard hook in tension (in.) (5.11.2.4.1)
ℓ_{hd}	=	development length for deformed wire fabric (in.) (5.11.2.5.1)
ℓ_i	=	length of tendon between anchorages (in.) (5.7.3.1.2)
ℓ_{px}	=	distance from free end of pretensioned strand to section of member under consideration (in.) (C5.11.4.2)
ℓ_s	=	Class C tension lap splice length of the column longitudinal reinforcement (in.) (5.11.5.2.1)
ℓ_u	=	unsupported length of a compression member (in.) (5.7.4.1)
M_a	=	maximum moment in a member at the stage for which deformation is computed (kip-in.) (5.7.3.6.2)
M_c	=	magnified moment used for proportioning slender compression members (kip-in.) (5.7.4.3)
M_{cr}	=	cracking moment (kip-in.) (5.7.3.3.2) (5.7.3.6.2)
M_{dnc}	=	total unfactored dead load moment acting on the monolithic or noncomposite section (kip-in.) (5.7.3.3.2)
M_{end}	=	moment at the ends of a hypothetical unreinforced concrete beam consisting of the cover concrete over the inside face of a stack of horizontally curved post-tensioned tendons (in.-k) (5.10.4.3.1)
M_g	=	midspan moment due to member self-weight (kip-in.) (C5.9.5.2.3a)
M_{mid}	=	moment at the midpoint of a hypothetical unreinforced concrete beam consisting of the cover concrete over the inside face of a stack of horizontally curved prestress post-tensioned (in.-k) (5.10.4.3.1)
M_n	=	nominal flexural resistance (kip-in.) (5.7.3.2.1)
M_r	=	factored flexural resistance of a section in bending (kip-in.) (5.7.3.2.1)
M_{rx}	=	uniaxial factored flexural resistance of a section in the direction of the x -axis (kip-in.) (5.7.4.5)
M_{ry}	=	uniaxial factored flexural resistance of a section in the direction of the y -axis (kip-in.) (5.7.4.5)
M_u	=	factored moment at the section (kip-in.) (C5.6.3.1)
M_{ux}	=	component of moment due to factored load in the direction of the x -axis (kip-in.) (5.7.4.5)
M_{uy}	=	component of moment due to factored load in the direction of the y -axis (kip-in.) (5.7.4.5)
M_1	=	smaller end moment at the strength limit state due to factored load acting on a compression member; positive if the member is bent in single curvature and negative if bent in double curvature (kip-in.) (5.7.4.3)
M_2	=	larger end moment at the strength limit state due to factored load acting on a compression member; always positive (kip-in.) (5.7.4.3)
m	=	modification factor (5.7.5)
N	=	the number of cycles of stress range; the number of identical prestressing tendons (5.5.3.4) (5.9.5.2.3b)
N_R	=	factored tensile resistance of transverse pair of reinforcing bars (kip) (5.13.2.3)
N_s	=	number of support hinges crossed by the tendon between anchorages or discretely bonded points (5.7.3.1.2)
N_u	=	applied factored axial force taken as positive if tensile (kip) (5.8.3.4.2)
N_{uc}	=	factored axial force normal to the cross-section, occurring simultaneously with V_u ; taken to be positive for tension and negative for compression; includes effects of tension due to creep and shrinkage (kip) (5.13.2.4.1)
N_1	=	number of tendons in the larger group (C5.9.5.2.3b)
N_2	=	number of tendons in the smaller group (C5.9.5.2.3b)
n	=	modular ratio = E_s/E_c or E_p/E_c ; number of anchorages in a row; projection of base plate beyond the wedge hole or wedge plate, as appropriate (in.); modular ratio between deck concrete and reinforcement (5.7.1) (5.10.9.6.2) (5.10.9.7.2) (C5.14.1.4.3)
ϕ_{cont}	=	girder web continuity factor for evaluating regional bending (5.10.4.3.1)

P_c	= permanent net compressive force (kip) (5.8.4.1)
P_n	= nominal axial resistance of a section (kip); nominal axial resistance of strut or tie (kip); nominal bearing resistance (kip) (5.5.4.2.1) (5.6.3.2) (5.7.5)
P_o	= nominal axial resistance of a section at 0.0 eccentricity (kip) (5.7.4.5)
P_r	= factored axial resistance of strut or tie (kip); factored bearing resistance of anchorages (kip); factored bursting resistance of pretensioned anchorage zone provided by transverse reinforcement (kip) (5.6.3.2) (5.10.9.7.2) (5.10.10.1)
P_{rx}	= factored axial resistance corresponding to M_{rx} (kip) (5.7.4.5)
P_{rxy}	= factored axial resistance with biaxial loading (kip) (5.7.4.5)
P_{ry}	= factored axial resistance corresponding to M_{ry} (kip) (5.7.4.5)
P_s	= maximum unfactored anchorage stressing force (kip) (5.10.9.3.4b)
P_u	= factored axial force effect or factored tendon force (kip); factored tendon load on an individual anchor (kip) (5.7.4.3) (5.10.9.3.6)
p_c	= length of outside perimeter of the concrete section (in.) (5.8.2.1) (5.8.6.3)
p_h	= perimeter of the centerline of the closed transverse torsion reinforcement (in.); perimeter of the polygon defined by the centroids of the longitudinal chords of the space truss resisting torsion (in.) (5.8.2.1) (5.8.6.4)
Q	= force effect in associated units (5.14.2.3.4)
R	= radius of curvature of the tendon at the considered location (ft) (5.10.4.3.1)
r	= radius of gyration of gross cross-section (in.) (5.7.4.1)
r/h	= ratio of base radius to height of rolled-on transverse deformations (5.5.3.2)
S	= center-to-center spacing of bearing along a beam ledge (in.) (5.13.2.5.2)
S_c	= section modulus for the extreme fiber of the composite section where tensile stress is caused by externally applied loads (in. ³) (5.7.3.3.2)
SH	= shrinkage (5.14.2.3.2)
S_{nc}	= section modulus for the extreme fiber of the monolithic or noncomposite section where tensile stress is caused by externally applied loads (in. ³) (5.7.3.3.2)
S_{tr}	= spacing of transverse shaft reinforcement (in.) (5.11.5.2.1)
s	= average spacing of mild steel reinforcement in layer closest to tension face (in.); spacing of reinforcing bars (in.); spacing of rows of ties (in.); anchorage spacing (in.); center-to-center spacing of anchorages (in.); spacing of hanger reinforcing bars (in.) (5.7.3.4) (5.8.2.5) (5.8.4.1) (5.10.9.3.6) (5.10.9.6.2) (5.13.2.5.5)
s_{max}	= maximum permitted spacing of transverse reinforcement (in.) (5.8.2.7)
s_w	= spacing of wires to be developed or spliced (in.) (5.11.2.5.1)
s_x	= crack spacing parameter (in.) (C5.8.3.4.2)
s_{xe}	= equivalent value of s_x which allows for influence of aggregate size (in.) (5.8.3.4.2)
T_{burst}	= tensile force in the anchorage zone acting ahead of the anchorage device and transverse to the tendon axis (kip) (5.10.9.6.3)
T_{cr}	= torsional cracking resistance (kip-in.) (5.8.2.1)
T_{ia}	= tie-back tension force at the intermediate anchorage (kip) (5.10.9.3.4b)
T_n	= nominal torsion resistance (kip-in.) (5.8.2.1)
T_r	= factored torsional resistance provided by circulatory shear flow (kip-in.) (5.8.2.1)
T_u	= factored torsional moment (kip-in.) (C5.6.3.1)
T_1	= edge tension force (kip) (5.10.9.3.6)
T_2	= bursting force (kip) (5.10.9.3.6)
t	= time (day); thickness of wall (in.); thickness of the section (in.); average thickness of bearing plate (in.) (5.4.2.3.2) (5.7.4.7.1) (5.10.9.6.2) (5.10.9.7.2)
t_d	= age at deck placement (day) (5.9.5.4.2b)
t_f	= final age (day) (5.9.5.4.2a)
t_i	= age of concrete when load is initially applied (day) (5.4.2.3.2)
U	= for segmental construction: segment unbalance (kip) (5.14.2.3.2)
V_c	= nominal shear resistance provided by tensile stresses in the concrete (kip) (5.8.2.4)
V_n	= nominal shear resistance of the section considered (kip) (5.8.2.1)
V_p	= component in the direction of the applied shear of the effective prestressing force; positive if resisting the applied shear (kip) (C5.8.2.3)
V_r	= factored shear resistance (kip) (5.8.2.1)
V/S	= volume-to-surface ratio (5.4.2.3.2)
V_s	= shear resistance provided by shear reinforcement (kip) (5.8.3.3)
V_u	= factored shear force at section (kip) (C5.6.3.1)

v_u	=	average factored shear stress on the concrete (ksi) (5.8.2.7) (5.8.2.9)
W	=	width of bearing plate measured along the length of a corbel, bracket, or beam ledge (in.) (C5.13.2.5.1)
W/C	=	water–cement ratio (5.12.3)
WE	=	for segmental construction: horizontal wind load on equipment (kip) (5.14.2.3.2)
WUP	=	for segmental construction: wind uplift on cantilever (ksf) (5.14.2.3.2)
w_c	=	unit weight of concrete (kcf) (5.4.2.4)
X_u	=	clear length of the constant thickness portion of a wall between other walls or fillers between walls (in.) (5.7.4.7.1)
x	=	length of a prestressing tendon from the jacking end to any point under consideration (ft) (5.9.5.2.2b)
y_t	=	distance from the neutral axis to the extreme tension fiber (in.) (5.7.3.6.2)
α	=	angle of inclination of transverse reinforcement to longitudinal axis (degrees); total angular change of prestressing steel path from jacking end to a point under investigation (rad.); the angle of inclination of a tendon force with respect to the centerline of the member (degrees) (5.8.3.3) (5.9.5.2.2b) (5.10.9.6.3)
α_h	=	total horizontal angular change of prestressing steel path from jacking end to a point under investigation (rad.) (5.9.5.2.2b)
α_s	=	angle between compressive strut and adjoining tension tie (degrees) (5.6.3.3.3)
α_v	=	total vertical angular change of prestressing steel path from jacking end to a point under investigation (rad.) (5.9.5.2.2b)
β	=	factor relating effect of longitudinal strain on the shear capacity of concrete, as indicated by the ability of diagonally cracked concrete to transmit tension; ratio of long side to short side of footing (5.8.3.3) (5.13.3.5)
β_b	=	ratio of the area of reinforcement cut off to the total area of tension reinforcement at the section (5.11.1.2.1)
β_c	=	ratio of the long side to the short side of the concentrated load or reaction area (5.13.3.6.3)
β_d	=	ratio of maximum factored dead load moments to maximum factored total load moment; always positive (5.7.4.3)
β_1	=	ratio of the depth of the equivalent uniformly stressed compression zone assumed in the strength limit state to the depth of the actual compression zone (5.7.2.2)
β_s	=	ratio of flexural strain at the extreme tension face to the strain at the centroid of the reinforcement layer nearest the tension face (5.7.3.4)
γ	=	load factor
γ_e	=	crack control exposure condition factor (5.7.3.4)
Δf	=	live load stress range due to fatigue load (ksi) (5.5.3.1)
$(\Delta F)_{TH}$	=	constant-amplitude fatigue threshold (ksi) (5.5.3.1)
Δf_{cd}	=	change in concrete stress at centroid of prestressing strands due to long-term losses between transfer and deck placement, combined with deck weight and superimposed loads (ksi) (5.9.5.4.3b)
Δf_{cdf}	=	change in concrete stress at centroid of prestressing strands due to shrinkage of deck concrete (ksi) (5.9.5.4.3d)
Δf_{cdp}	=	change in concrete stress at c.g. of prestressing steel due to all dead loads, except dead load acting at the time the prestressing force is applied (ksi) (5.9.5.4.3)
Δf_{pA}	=	loss in prestressing steel stress due to anchorage set (ksi) (5.9.5.1)
Δf_{pCD}	=	prestress loss due to creep of girder concrete between time of deck placement and final time (ksi) (5.9.5.4.1)
Δf_{pCR}	=	prestress loss due to creep of girder concrete between transfer and deck placement (ksi) (5.9.5.4.1)
Δf_{pES}	=	loss in prestressing steel stress due to elastic shortening (ksi) (5.9.5.1)
Δf_{pF}	=	loss in prestressing steel stress due to friction (ksi) (5.9.5.1)
Δf_{pR1}	=	prestress loss due to relaxation of prestressing strands between transfer and deck placement (ksi) (5.9.5.4.1)
Δf_{pR2}	=	prestress loss due to relaxation of prestressing strands in composite section between time of deck placement and final time (ksi) (5.9.5.4.1)
Δf_{pSD}	=	prestress loss due to shrinkage of girder concrete between time of deck placement and final time (ksi) (5.9.5.4.1)
Δf_{pSR}	=	prestress loss due to shrinkage of girder concrete between transfer and deck placement (ksi) (5.9.5.4.1)
Δf_{pSS}	=	prestress loss due to shrinkage of deck composite section (ksi) (5.9.5.4.1)
Δf_{pT}	=	total loss in prestressing steel stress (ksi) (5.9.5.1)
ϵ_{bdf}	=	shrinkage strain of girder between time of deck placement and final time (in./in.) (5.9.5.4.3a)
ϵ_{bid}	=	concrete shrinkage strain of girder between transfer and deck placement (in./in.) (5.9.5.4.2a)
ϵ_{cu}	=	failure strain of concrete in compression (in./in.) (5.7.3.1.2) (5.7.4.4)
ϵ_{ddf}	=	shrinkage strain of deck concrete between placement and final time (in./in.) (5.9.5.4.3d)

$\epsilon_{effective}$	=	effective concrete shrinkage strain (in./in.) (C5.14.1.4.3)
ϵ_s	=	tensile strain in cracked concrete in direction of tension tie (in./in.); net longitudinal tensile strain in the section at the centroid of the tension reinforcement (in./in.) (5.6.3.3.3) (5.8.3.4.2)
ϵ_{sh}	=	concrete shrinkage strain at a given time (in./in.); net longitudinal tensile strain in the section at the centroid of the tension reinforcement (in./in.) (5.4.2.3.3) (C5.14.1.4.3)
ϵ_t	=	net tensile strain in extreme tension steel at nominal resistance (C5.5.4.2.1)
ϵ_x	=	longitudinal strain in the web of the member (in./in.) (Appendix B5)
ϵ_1	=	principal tensile strain in cracked concrete due to factored loads (in./in.) (5.6.3.3.3)
θ	=	angle of inclination of diagonal compressive stresses (degrees) (5.8.3.3)
θ_s	=	angle between compression strut and longitudinal axis of the member in a shear truss model of a beam (degrees) (5.6.3.3.2)
κ	=	correction factor for closely spaced anchorages; multiplier for strand development length (5.10.9.6.2) (5.11.4.2)
λ	=	parameter used to determine friction coefficient μ (5.8.4.2)
λ_w	=	wall slenderness ratio for hollow columns (5.7.4.7.1)
μ	=	coefficient of friction (5.8.4.1)
ρ_h	=	ratio of area of horizontal shear reinforcement to area of gross concrete area of a vertical section (5.10.11.4.2)
ρ_{min}	=	minimum ratio of tension reinforcement to effective concrete area (5.7.3.3.2)
ρ_s	=	ratio of spiral reinforcement to total volume of column core (5.7.4.6)
ρ_v	=	ratio of area of vertical shear reinforcement to area of gross concrete area of a horizontal section (5.10.11.4.2)
ϕ	=	resistance factor (5.5.4.2.1)
ϕ_w	=	hollow column reduction factor (5.7.4.7.2)
$\Psi(t, t_i)$	=	creep coefficient—the ratio of the creep strain that exists t days after casting to the elastic strain caused when load p_i is applied t_i days after casting (5.4.2.3.2)
$\Psi_b(t_d, t_i)$	=	girder creep coefficient at time of deck placement due to loading introduced at transfer (5.9.5.4.2b)
$\Psi_b(t_f, t_d)$	=	girder creep coefficient at final time due to loading at deck placement; creep coefficient of deck concrete at final time due to loading introduced shortly after deck placement (i.e., overlays, barriers, etc.) (5.9.5.4.3b) (5.9.5.4.3d)
$\Psi_b(t_f, t_i)$	=	girder creep coefficient at final time due to loading introduced at transfer (5.9.5.4.2a)

5.4—MATERIAL PROPERTIES

5.4.1—General

Designs should be based on the material properties cited herein and on the use of materials that conform to the standards for the grades of construction materials as specified in *AASHTO LRFD Bridge Construction Specifications*.

When other grades or types of materials are used, their properties, including statistical variability, shall be established prior to design. The minimum acceptable properties and test procedures for such materials shall be specified in the contract documents.

The contract documents shall define the grades or properties of all materials to be used.

C5.4.1

According to *AASHTO LRFD Bridge Construction Specifications*, all materials and tests must conform to the appropriate standards included in the *AASHTO Standard Specifications for Transportation Materials and Methods of Sampling and Testing* and/or the standards of the American Society for Testing and Materials.

Occasionally, it may be appropriate to use materials other than those included in the *AASHTO LRFD Bridge Construction Specifications*; for example, when concretes are modified to obtain very high-strengths through the introduction of special materials, such as:

- Silica fume,
- Cements other than Portland or blended hydraulic cements,
- Proprietary high early strength cements,
- Ground granulated blast-furnace slag, and
- Other types of cementitious and/or Pozzolanic materials.

5.4.2—Normal Weight and Structural Lightweight Concrete

5.4.2.1—Compressive Strength

For each component, the specified compressive strength, f'_c , or the class of concrete shall be shown in the contract documents.

Design concrete strengths above 10.0 ksi for normal weight concrete shall be used only when allowed by specific Articles or when physical tests are made to establish the relationships between the concrete strength and other properties. Specified concrete with strengths below 2.4 ksi should not be used in structural applications.

The specified compressive strength for prestressed concrete and decks shall not be less than 4.0 ksi.

For lightweight structural concrete, air dry unit weight, strength and any other properties required for the application shall be specified in the contract documents.

In these cases, the specified properties of such materials should be measured using the testing procedures defined in the contract documents.

C5.4.2.1

The evaluation of the strength of the concrete used in the work should be based on test cylinders produced, tested, and evaluated in accordance with Section 8 of the *AASHTO LRFD Bridge Construction Specifications*.

This Section was originally developed based on an upper limit of 10.0 ksi for the design concrete compressive strength. As research information for concrete compressive strengths greater than 10.0 ksi becomes available, individual Articles are being revised or extended to allow their use with higher strength concretes. Appendix C5 contains a listing of the Articles affected by concrete compressive strength and their current upper limit.

It is common practice that the specified strength be attained 28 days after placement. Other maturity ages may be assumed for design and specified for components that will receive loads at times appreciably different than 28 days after placement.

It is recommended that the classes of concrete shown in Table C5.4.2.1-1 and their corresponding specified strengths be used whenever appropriate. The classes of concrete indicated in Table C5.4.2.1-1 have been developed for general use and are included in *AASHTO LRFD Bridge Construction Specifications*, Section 8, "Concrete Structures," from which Table C5.4.2.1-1 was taken.

These classes are intended for use as follows:

- Class A concrete is generally used for all elements of structures, except when another class is more appropriate, and specifically for concrete exposed to saltwater.
- Class B concrete is used in footings, pedestals, massive pier shafts, and gravity walls.
- Class C concrete is used in thin sections, such as reinforced railings less than 4.0 in. thick, for filler in steel grid floors, etc.
- Class P concrete is used when strengths in excess of 4.0 ksi are required. For prestressed concrete, consideration should be given to limiting the nominal aggregate size to 0.75 in.
- Class S concrete is used for concrete deposited underwater in cofferdams to seal out water.

Strengths above 5.0 ksi should be used only when the availability of materials for such concrete in the locale is verified.

Lightweight concrete is generally used only under conditions where weight is critical.

In the evaluation of existing structures, it may be appropriate to modify the f'_c and other attendant structural properties specified for the original construction to recognize the strength gain or any strength loss due to age or deterioration after 28 days. Such modified f'_c should be determined by core samples of sufficient number and size to represent the concrete in the work, tested in accordance with AASHTO T 24M/T 24 (ASTM C42/C42M).

There is considerable evidence that the durability of reinforced concrete exposed to saltwater, deicing salts, or sulfates is appreciably improved if, as recommended by ACI 318, either or both the cover over the reinforcing steel is increased or the W/C ratio is limited to 0.40. If materials, with reasonable use of admixtures, will produce a workable concrete at W/C ratios lower than those listed in Table C5.4.2.1-1, the contract documents should alter the recommendations in Table C5.4.2.1-1 appropriately.

The specified strengths shown in Table C5.4.2.1-1 are generally consistent with the W/C ratios shown. However, it is possible to satisfy one without the other. Both are specified because W/C ratio is a dominant factor contributing to both durability and strength; simply obtaining the strength needed to satisfy the design assumptions may not ensure adequate durability.

For concrete Classes A, A(AE), and P used in or over saltwater, the W/C ratio shall be specified not to exceed 0.45.

The sum of Portland cement and other cementitious materials shall be specified not to exceed 800 pcy, except for Class P (HPC) concrete where the sum of Portland cement and other cementitious materials shall be specified not to exceed 1000 pcy.

Air-entrained concrete, designated "AE" in Table C5.4.2.1-1, shall be specified where the concrete will be subject to alternate freezing and thawing and exposure to deicing salts, saltwater, or other potentially damaging environments.

Table C5.4.2.1-1—Concrete Mix Characteristics by Class

Class of Concrete	Minimum Cement Content	Maximum W/C Ratio	Air Content Range	Coarse Aggregate Per AASHTO M 43 (ASTM D448)	28-Day Compressive Strength
	pcy	lbs. Per lbs.	%	Square Size of Openings (in.)	ksi
A	611	0.49	—	1.0 to No. 4	4.0
A(AE)	611	0.45	6.0 ± 1.5	1.0 to No. 4	4.0
B	517	0.58	—	2.0 to No. 3 and No. 3 to No. 4	2.4
B(AE)	517	0.55	5.0 ± 1.5	2.0 to No. 3 and No. 3 to No. 4	2.4
C	658	0.49	—	0.5 to No. 4	4.0
C(AE)	658	0.45	7.0 ± 1.5	0.5 to No. 4	4.0
P P(HPC)	564	0.49	As specified elsewhere	1.0 to No. 4 or 0.75 to No. 4	As specified elsewhere
S	658	0.58	—	1.0 to No. 4	—
Lightweight	564	As specified in the contract documents			

5.4.2.2—Coefficient of Thermal Expansion

The coefficient of thermal expansion should be determined by the laboratory tests on the specific mix to be used.

In the absence of more precise data, the thermal coefficient of expansion may be taken as:

- For normal weight concrete: $6.0 \times 10^{-6}/^{\circ}\text{F}$, and
- For lightweight concrete: $5.0 \times 10^{-6}/^{\circ}\text{F}$

5.4.2.3—Shrinkage and Creep*5.4.2.3.1—General*

Values of shrinkage and creep, specified herein and in Articles 5.9.5.3 and 5.9.5.4, shall be used to determine the effects of shrinkage and creep on the loss of prestressing force in bridges other than segmentally constructed ones. These values in conjunction with the moment of inertia, as specified in Article 5.7.3.6.2, may be used to determine the effects of shrinkage and creep on deflections.

These provisions shall be applicable for specified concrete strengths up to 15.0 ksi. In the absence of more accurate data, the shrinkage coefficients may be assumed to be 0.0002 after 28 days and 0.0005 after one year of drying.

When mix-specific data are not available, estimates of shrinkage and creep may be made using the provisions of:

- Articles 5.4.2.3.2 and 5.4.2.3.3,
- The CEB-FIP model code, or
- ACI 209.

For segmentally constructed bridges, a more precise estimate shall be made, including the effect of:

- Specific materials,
- Structural dimensions,
- Site conditions, and
- Construction methods, and
- Concrete age at various stages of erection.

5.4.2.3.2—Creep

The creep coefficient may be taken as:

$$\psi(t, t_i) = 1.9k_s k_{hc} k_f k_{td} t_i^{-0.118} \quad (5.4.2.3.2-1)$$

C5.4.2.2

The thermal coefficient depends primarily on the types and proportions of aggregates used and on the degree of saturation of the concrete.

The thermal coefficient of normal weight concrete can vary between 3.0 to $8.0 \times 10^{-6}/^{\circ}\text{F}$, with limestone and marble aggregates producing the lower values, and chert and quartzite the higher. Only limited determinations of these coefficients have been made for lightweight concretes. They are in the range of 4.0 to $6.0 \times 10^{-6}/^{\circ}\text{F}$ and depend on the amount of natural sand used.

Additional information may be found in ACI 209, ACI 343 and ACI 213.

C5.4.2.3.1

Creep and shrinkage of concrete are variable properties that depend on a number of factors, some of which may not be known at the time of design.

Without specific physical tests or prior experience with the materials, the use of the empirical methods referenced in these Specifications cannot be expected to yield results with errors less than ± 50 percent.

C5.4.2.3.2

The methods of determining creep and shrinkage, as specified herein and in Article 5.4.2.3.3, are based on Huo et al. (2001), Al-Omaishi (2001), Tadros (2003), and Collins and Mitchell (1991). These methods are

in which:

$$k_s = 1.45 - 0.13(V/S) \geq 1.0 \quad (5.4.2.3.2-2)$$

$$k_{hc} = 1.56 - 0.008H \quad (5.4.2.3.2-3)$$

$$k_f = \frac{5}{1 + f'_{ci}} \quad (5.4.2.3.2-4)$$

$$k_{td} = \left(\frac{t}{61 - 4f'_{ci} + t} \right) \quad (5.4.2.3.2-5)$$

where:

H = relative humidity (%). In the absence of better information, H may be taken from Figure 5.4.2.3.3-1.

k_s = factor for the effect of the volume-to-surface ratio of the component

k_f = factor for the effect of concrete strength

k_{hc} = humidity factor for creep

k_{td} = time development factor

t = maturity of concrete (day), defined as age of concrete between time of loading for creep calculations, or end of curing for shrinkage calculations, and time being considered for analysis of creep or shrinkage effects

t_i = age of concrete at time of load application (day)

V/S = volume-to-surface ratio (in.)

f'_{ci} = specified compressive strength of concrete at time of prestressing for pretensioned members and at time of initial loading for nonprestressed members. If concrete age at time of initial loading is unknown at design time, f'_{ci} may be taken as $0.80 f'_c$ (ksi).

The surface area used in determining the volume-to-surface ratio should include only the area that is exposed to atmospheric drying. For poorly ventilated enclosed cells, only 50 percent of the interior perimeter should be used in calculating the surface area. For precast members with cast-in-place topping, the total precast surface should be used. For pretensioned stemmed members (I-beams, T-beams, and box beams), with an average web thickness of 6.0 to 8.0 in., the value of k_{vs} may be taken as 1.00.

based on the recommendation of ACI Committee 209 as modified by additional recently published data. Other applicable references include Rusch et al. (1983), Bazant and Wittman (1982), and Ghali and Favre (1986).

The creep coefficient is applied to the compressive strain caused by permanent loads in order to obtain the strain due to creep.

Creep is influenced by the same factors as shrinkage, and also by:

- Magnitude and duration of the stress,
- Maturity of the concrete at the time of loading, and
- Temperature of concrete.

Creep shortening of concrete under permanent loads is generally in the range of 0.5 to 4.0 times the initial elastic shortening, depending primarily on concrete maturity at the time of loading.

The time development of shrinkage, given by Eq. 5.4.2.3.2-5, is proposed to be used for both precast concrete and cast-in-place concrete components of a bridge member, and for both accelerated curing and moist curing conditions. This simplification is based on a parametric study documented in Tadros (2003), on prestress losses in high strength concrete. It was found that various time development prediction methods have virtually no impact on the final creep and shrinkage coefficients, prestress losses, or member deflections. It was also observed in that study that use of modern concrete mixtures with relatively low water/cement ratios and with high range water reducing admixtures, has caused time development of both creep and shrinkage to have similar patterns. They have a relatively rapid initial development in the first several weeks after concrete placement and a slow further growth thereafter. For calculation of intermediate values of prestress losses and deflections in cast-in-place segmental bridges constructed with the balanced cantilever method, it may be warranted to use actual test results for creep and shrinkage time development using local conditions. Final losses and deflections would be substantially unaffected whether Eq. 5.4.2.3.2-5 or another time-development formula is used.

The factors for the effects of volume-to-surface ratio are an approximation of the following formulas:

For creep:

$$k_c = \left[\frac{t}{26 e^{0.36(V/S)} + t} \right] \left[\frac{1.80 + 1.77 e^{-0.54(V/S)}}{2.587} \right] \quad (C5.4.2.3.2-1)$$

For shrinkage:

$$k_s = \left[\frac{\frac{t}{26e^{0.36(V/S)} + t}}{\frac{t}{45 + t}} \right] \left[\frac{1064 - 94(V/S)}{923} \right] \quad (\text{C5.4.2.3.2-2})$$

The maximum V/S ratio considered in the development of Eqs. C5.4.2.3.2-1 and C5.4.2.3.2-2 was 6.0 in.

Ultimate creep and shrinkage are less sensitive to surface exposure than intermediate values at an early age of concrete. For accurately estimating intermediate deformations of such specialized structures as segmentally constructed balanced cantilever box girders, it may be necessary to resort to experimental data or use the more detailed Eqs. C5.4.2.3.2-1 and C5.4.2.3.2-2.

5.4.2.3.3—Shrinkage

For concretes devoid of shrinkage-prone aggregates, the strain due to shrinkage, ϵ_{sh} , at time, t , may be taken as:

$$\epsilon_{sh} = k_s k_{hs} k_f k_{td} 0.48 \times 10^{-3} \quad (\text{5.4.2.3.3-1})$$

in which:

$$k_{hs} = (2.00 - 0.014 H) \quad (\text{5.4.2.3.3-2})$$

where:

$$k_{hs} = \text{humidity factor for shrinkage}$$

If the concrete is exposed to drying before 5 days of curing have elapsed, the shrinkage as determined in Eq. 5.4.2.3.3-1 should be increased by 20 percent.

C5.4.2.3.3

Shrinkage of concrete can vary over a wide range from nearly nil if continually immersed in water to in excess of 0.0008 for thin sections made with high shrinkage aggregates and sections that are not properly cured.

Shrinkage is affected by:

- Aggregate characteristics and proportions,
- Average humidity at the bridge site,
- W/C ratio,
- Type of cure,
- Volume to surface area ratio of member, and
- Duration of drying period.

Large concrete members may undergo substantially less shrinkage than that measured by laboratory testing of small specimens of the same concrete. The constraining effects of reinforcement and composite actions with other elements of the bridge tend to reduce the dimensional changes in some components.

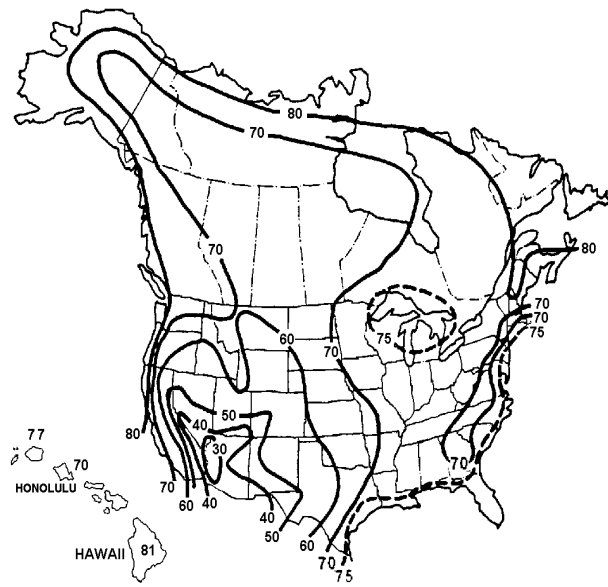

Figure 5.4.2.3.3-1—Annual Average Ambient Relative Humidity in Percent

5.4.2.4—Modulus of Elasticity

In the absence of measured data, the modulus of elasticity, E_c , for concretes with unit weights between 0.090 and 0.155 kcf and specified compressive strengths up to 15.0 ksi may be taken as:

$$E_c = 33,000 K_1 w_c^{1.5} \sqrt{f'_c} \quad (5.4.2.4-1)$$

where:

- K_1 = correction factor for source of aggregate to be taken as 1.0 unless determined by physical test, and as approved by the authority of jurisdiction
- w_c = unit weight of concrete (kcf); refer to Table 3.5.1-1 or Article C5.4.2.4
- f'_c = specified compressive strength of concrete (ksi)

5.4.2.5—Poisson’s Ratio

Unless determined by physical tests, Poisson’s ratio may be assumed as 0.2. For components expected to be subject to cracking, the effect of Poisson’s ratio may be neglected.

5.4.2.6—Modulus of Rupture

Unless determined by physical tests, the modulus of rupture, f_r , for specified concrete strengths up to 15.0 ksi may be taken as:

- For normal-weight concrete:
 - Except as specified below..... $0.24\sqrt{f'_c}$

C5.4.2.4

See commentary for specified strength in Article 5.4.2.1.

For normal weight concrete with $w_c = 0.145$ kcf, E_c may be taken as:

$$E_c = 1,820\sqrt{f'_c} \quad (C5.4.2.4-1)$$

Test data show that the modulus of elasticity of concrete is influenced by the stiffness of the aggregate. The factor K_1 is included to allow the calculated modulus to be adjusted for different types of aggregate and local materials. Unless a value has been determined by physical tests, K_1 should be taken as 1.0. Use of a measured K_1 factor permits a more accurate prediction of modulus of elasticity and other values that utilize it.

C5.4.2.5

This is a ratio between the lateral and axial strains of an axially and/or flexurally loaded structural element.

C5.4.2.6

Most modulus of rupture test data on normal weight concrete is between $0.24\sqrt{f'_c}$ and $0.37\sqrt{f'_c}$ (ksi) (Walker and Bloem, 1960; Khan, Cook, and Mitchell, 1996). A value of $0.37\sqrt{f'_c}$ has been recommended for the prediction of the tensile strength of high-strength concrete (ACI, 1992). However, the modulus of rupture is sensitive to curing methods and nearly all of the test

- When used to calculate the cracking moment of a member in Article 5.8.3.4.3 $0.20\sqrt{f'_c}$
- For lightweight concrete:
 - For sand—lightweight concrete $0.20\sqrt{f'_c}$
 - For all—lightweight concrete $0.17\sqrt{f'_c}$

When physical tests are used to determine modulus of rupture, the tests shall be performed in accordance with AASHTO T 97 and shall be performed on concrete using the same proportions and materials as specified for the structure.

units in the dataset mentioned previously were moist cured until testing. Carrasquillio et al. (1981) noted a 26 percent reduction in the 28-day modulus of rupture if high-strength units were allowed to dry after 7 days of moist curing over units that were moist cured until testing.

The flexural cracking stress of concrete members has been shown to significantly reduce with increasing member depth. Shioya et al. (1989) observed that the flexural cracking strength is proportional to $H^{-0.25}$ where H is the overall depth of the flexural member in inches. Based on this observation, a 36.0 in. deep girder should achieve a flexural cracking stress that is 36 percent lower than that of a 6.0 in. deep modulus of rupture test.

Since modulus of rupture units were either 4.0 or 6.0 in. deep and moist cured up to the time of testing, the modulus of rupture should be significantly greater than that of an average size bridge member composed of the same concrete. Therefore, $0.24\sqrt{f'_c}$ is appropriate for checking minimum reinforcement in Article 5.7.3.3.2.

The properties of higher-strength concretes are particularly sensitive to the constitutive materials. If test results are to be used in design, it is imperative that tests be made using concrete with not only the same mix proportions but also the same materials as the concrete used in the structure.

The given values may be unconservative for tensile cracking caused by restrained shrinkage, anchor zone splitting, and other such tensile forces caused by effects other than flexure. The direct tensile strength stress should be used for these cases.

5.4.2.7—Tensile Strength

Direct tensile strength may be determined by either using ASTM C900, or the split tensile strength method in accordance with AASHTO T 198 (ASTM C496).

5.4.3—Reinforcing Steel

5.4.3.1—General

Reinforcing bars, deformed wire, cold-drawn wire, welded plain wire fabric, and welded deformed wire fabric shall conform to the material standards as specified in Article 9.2 of the *AASHTO LRFD Bridge Construction Specifications*.

Reinforcement shall be deformed, except that plain bars or plain wire may be used for spirals, hoops, and wire fabric.

The nominal yield strength shall be the minimum as specified for the grade of steel selected, except that yield strengths in excess of 75.0 ksi shall not be used for design purposes. The yield strength or grade of the bars or wires shall be shown in the contract documents. Bars with yield strengths less than 60.0 ksi shall be used only with the approval of the Owner.

C5.4.2.7

For normal-weight concrete with specified compressive strengths up to 10 ksi, the direct tensile strength may be estimated as $f_r = 0.23\sqrt{f'_c}$.

C5.4.3.1

Where ductility is to be assured or where welding is required, steel conforming to the requirements of ASTM A706, “Low Alloy Steel Deformed Bars for Concrete Reinforcement,” should be specified.

5.4.3.2—Modulus of Elasticity

The modulus of elasticity, E_s , of steel reinforcing shall be assumed as 29,000 ksi.

5.4.3.3—Special Applications

Reinforcement to be welded shall be indicated in the contract documents, and the welding procedure to be used shall be specified.

Reinforcement conforming to ASTM A1035/A1035M may only be used as top and bottom flexural reinforcement in the longitudinal and transverse directions of bridge decks in Seismic Zones 1 and 2.

ASTM A706 reinforcement should be considered for seismic design because of the greater quality control by which unanticipated overstrength is limited.

C5.4.3.3

In 2004, ASTM published A1035/A1035M, *Standard Specification for Deformed and Plain, Low-carbon, Chromium, Steel Bars for Concrete Reinforcement*. This reinforcement offers the potential for corrosion resistance.

Epoxy-coated reinforcing steel provides a physical barrier to inhibit corrosion of the steel in the presence of chlorides. The handling, placement, and repair of epoxy-coated reinforcing steel requires significant care and attention.

Reinforcement conforming to ASTM A1035/A1035M has a specified minimum yield strength of 100 ksi determined by the 0.2 percent offset method, a specified minimum tensile strength of 150 ksi, and a specified minimum elongation of six or seven percent depending on bar size. There is also a requirement that the stress corresponding to a tensile strain of 0.0035 shall be a minimum of 80 ksi. The reinforcement has a non-linear stress-strain relationship. Article 5.4.3.1 of the Design Specifications states that yield strengths in excess of 75.0 ksi shall not be used for design purposes. Consequently, design is based on a stress of 75.0 ksi, but the actual strength is at least twice that value. This has led to concerns about the applicability of the existing specifications with ASTM A1035 reinforcement. Consequently, it is proposed that initial usage of the reinforcement be restricted to top and bottom flexural reinforcement in the transverse and longitudinal directions of bridge decks in Seismic Zones 1 and 2.

5.4.4—Prestressing Steel

5.4.4.1—General

Uncoated, stress-relieved or low-relaxation, seven-wire strand, or uncoated plain or deformed, high-strength bars, shall conform to the following materials standards, as specified for use in *AASHTO LRFD Bridge Construction Specifications*:

- AASHTO M 203/M 203M (ASTM A416/A416M), or
- AASHTO M 275/M 275M (ASTM A722/A722M).

Tensile and yield strengths for these steels may be taken as specified in Table 5.4.4.1-1.

C5.4.4.1

Low relaxation strand shall be regarded as the standard type. Stress-relieved (normal relaxation) strand will not be furnished unless specifically ordered, or by arrangement between purchaser and supplier.

Table 5.4.4.1-1—Properties of Prestressing Strand and Bar

Material	Grade or Type	Diameter (in.)	Tensile Strength, f_{pu} (ksi)	Yield Strength, f_{py} (ksi)
Strand	250 ksi	1/4 to 0.6	250	85% of f_{pu} , except 90% of f_{pu} for low-relaxation strand
	270 ksi	3/8 to 0.6	270	
Bar	Type 1, Plain	3/4 to 1-3/8	150	85% of f_{pu}
	Type 2, Deformed	5/8 to 1-3/8	150	80% of f_{pu}

Where complete prestressing details are included in the contract documents, the size and grade or type of steel shall be shown. If the plans indicate only the prestressing forces and locations of application, the choice of size and type of steel shall be left to the Contractor, subject to the Engineer's approval.

5.4.4.2—Modulus of Elasticity

If more precise data are not available, the modulus of elasticity for prestressing steels, based on nominal cross-sectional area, may be taken as:

for strand: $E_p = 28,500$ ksi, and
for bar: $E_p = 30,000$ ksi

C5.4.4.2

The suggested modulus of elasticity of 28,500 ksi for strands is based on recent statistical data. This value is higher than that previously assumed because of the slightly different characteristics and the near universal use of low-relaxation strands.

As shown in Figure C5.4.4.2-1, there is no sharp break in the curves to indicate a distinct elastic limit or yield point. Arbitrary methods of establishing yield strength, based on a specific set or measured strain, are generally used. The 0.2 percent offset and the one percent extension methods are the most common.

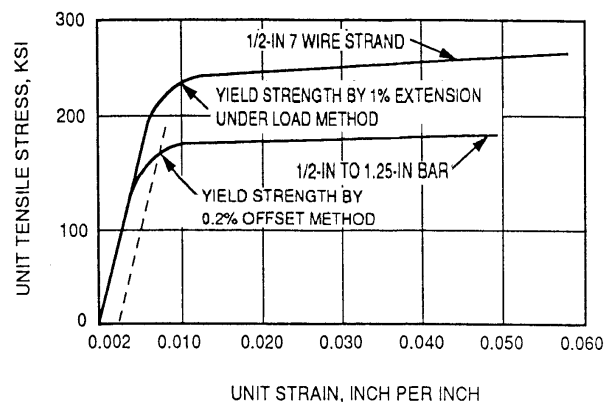

Figure C5.4.4.2-1—Typical Stress-Strain Curve for Prestressing Steels

5.4.5—Post-Tensioning Anchorages and Couplers

Anchorages and tendon couplers shall conform to the requirements of Article 10.3.2 of *AASHTO LRFD Bridge Construction Specifications*.

Corrosion protection shall be provided for tendons, anchorages, end fittings, and couplers.

C5.4.5

Complete details for qualification testing of anchorages and couplers are included in Article 10.3.2 of *AASHTO LRFD Bridge Construction Specifications*.

Characteristics of anchorages and couplers related to design and detailing are summarized below from *AASHTO LRFD Bridge Construction Specifications*:

- Anchorages and couplers are to develop at least 95 percent of the minimum specified ultimate strength of the prestressing steel without exceeding the anchorage set movement assumed for the design. Unbonded systems are to also pass a dynamic loading test.
- Couplers are not to be used at points of sharp tendon curvature.
- Couplers are to be used only at locations shown on the contract documents or approved by the Engineer.
- Couplers are to be enclosed in housings long enough to permit the necessary movements.
- Where bonded anchorages or couplers are located at sections that are critical at strength limit state, the strength required of the bonded tendons is not to exceed the resistance of the tendon assembly, including the anchorage or coupler, tested in an unbonded state.
- Bearing stresses on concrete under anchorage distribution plates are not to exceed specified limits.
- Unless waived by the Engineer because of suitable previous tests and/or experience, qualification of anchorages and couplers are to be verified by testing.

5.4.6—Ducts

5.4.6.1—General

Ducts for tendons shall be rigid or semirigid either galvanized ferrous metal or polyethylene, or they shall be formed in the concrete with removable cores.

The radius of curvature of tendon ducts shall not be less than 20.0 ft, except in the anchorage areas where 12.0 ft may be permitted.

Polyethylene ducts shall not be used when the radius of curvature of the tendon is less than 30.0 ft.

Where polyethylene ducts are used and the tendons are to be bonded, the bonding characteristics of polyethylene ducts to the concrete and the grout should be investigated.

The effects of grouting pressure on the ducts and the surrounding concrete shall be investigated.

The maximum support interval for the ducts during construction shall be indicated in the contract documents and shall conform to Article 10.4.1.1 of the *AASHTO LRFD Bridge Construction Specifications*.

5.4.6.2—Size of Ducts

The inside diameter of ducts shall be at least 0.25 in. larger than the nominal diameter of single bar or strand tendons. For multiple bar or strand tendons, the inside cross-sectional area of the duct shall be at least

C5.4.6.1

The use of polyethylene duct is generally recommended in corrosive environments. Pertinent requirements for ducts can be found in Article 10.8.2 in *AASHTO LRFD Bridge Construction Specifications*.

Polyethylene duct should not be used on radii under 30.0 ft because of its lower resistance to abrasion during pulling-through and stressing tendons.

The contract documents should indicate the specific type of duct material to be used when only one type is to be allowed.

C5.4.6.2

The pull-through method of tendon placement is usually employed by contractors where tendons exceed 400 ft in length.

2.0 times the net area of the prestressing steel with one exception where tendons are to be placed by the pull-through method, the duct area shall be at least 2.5 times the net area of the prestressing steel.

The size of ducts shall not exceed 0.4 times the least gross concrete thickness at the duct.

5.4.6.3—Ducts at Deviation Saddles

Ducts at deviation saddles shall be galvanized steel pipe conforming to the requirements of ASTM A53, Type E, Grade B. The nominal wall thickness of the pipe shall be not less than 0.125 in.

5.5—LIMIT STATES

5.5.1—General

Structural components shall be proportioned to satisfy the requirements at all appropriate service, fatigue, strength, and extreme event limit states.

Prestressed and partially prestressed concrete structural components shall be investigated for stresses and deformations for each stage that may be critical during construction, stressing, handling, transportation, and erection as well as during the service life of the structure of which they are part.

Stress concentrations due to prestressing or other loads and to restraints or imposed deformations shall be considered.

5.5.2—Service Limit State

Actions to be considered at the service limit state shall be cracking, deformations, and concrete stresses, as specified in Articles 5.7.3.4, 5.7.3.6, and 5.9.4, respectively.

The cracking stress shall be taken as the modulus of rupture specified in Article 5.4.2.6.

5.5.3—Fatigue Limit State

5.5.3.1—General

Fatigue need not be investigated for concrete deck slabs in multigirder applications or reinforced-concrete box culverts.

In regions of compressive stress due to permanent loads and prestress in reinforced concrete components, fatigue shall be considered only if this compressive stress is less than the maximum tensile live load stress resulting from the Fatigue I load combination as specified in Table 3.4.1-1 in combination with the provisions of Article 3.6.1.4.

C5.5.3.1

Stresses measured in concrete deck slabs of bridges in service are far below infinite fatigue life, most probably due to internal arching action; see Article C9.7.2.

Fatigue evaluation for reinforced-concrete box culverts showed that the live load stresses in the reinforcement due to Fatigue I load combination did not reduce the member resistance at the strength limit state.

In determining the need to investigate fatigue, Table 3.4.1-1 specifies a load factor of 1.50 on the live load force effect resulting from the fatigue truck for the Fatigue I load combination. This factored live load force effect represents the greatest fatigue stress that the bridge will experience during its life.

Fatigue of the reinforcement need not be checked for fully prestressed components designed to have extreme fiber tensile stress due to Service III Limit State within the tensile stress limit specified in Table 5.9.4.2.2-1. Structural components with a combination of prestressing strands and reinforcing bars that allow the tensile stress in the concrete to exceed the Service III limit specified in Table 5.9.4.2.2-1 shall be checked for fatigue.

For fatigue considerations, concrete members shall satisfy:

$$\gamma(\Delta f) \leq (\Delta F)_{TH} \quad (5.5.3.1-1)$$

where:

- γ = load factor specified in Table 3.4.1-1 for the Fatigue I load combination
- Δf = force effect, live load stress range due to the passage of the fatigue load as specified in Article 3.6.1.4 (ksi)
- $(\Delta F)_{TH}$ = constant-amplitude fatigue threshold, as specified in Article 5.5.3.2, 5.5.3.3, or 5.5.3.4, as appropriate (ksi)

For fully prestressed components in other than segmentally constructed bridges, the compressive stress due to the Fatigue I load combination and one-half the sum of effective prestress and permanent loads shall not exceed $0.40f'_c$ after losses.

The section properties for fatigue investigations shall be based on cracked sections where the sum of stresses, due to unfactored permanent loads and prestress, and the Fatigue I load combination is tensile and exceeds $0.095\sqrt{f'_c}$.

5.5.3.2—Reinforcing Bars

The constant-amplitude fatigue threshold, $(\Delta F)_{TH}$, for straight reinforcement and welded wire reinforcement without a cross weld in the high-stress region shall be taken as:

$$(\Delta F)_{TH} = 24 - 0.33f_{\min} \quad (5.5.3.2-1)$$

The constant-amplitude fatigue threshold, $(\Delta F)_{TH}$, for straight welded wire reinforcement with a cross weld in the high-stress region shall be taken as:

$$(\Delta F)_{TH} = 16 - 0.33f_{\min} \quad (5.5.3.2-2)$$

where:

Fatigue limit state load factor, girder distribution factors, and dynamic allowance cause fatigue limit state stress to be considerably less than the corresponding value determined from Service Limit State III. For fully prestressed components, the net concrete stress is usually significantly less than the concrete tensile stress limit specified in Table 5.9.4.2.2-1. Therefore, the calculated flexural stresses are significantly reduced. For this situation, the calculated steel stress range, which is equal to the modular ratio times the concrete stress range, is almost always less than the steel fatigue stress range limit specified in Article 5.5.3.3.

C5.5.3.2

Bends in primary reinforcement should be avoided in regions of high stress range.

Structural welded wire reinforcement has been increasingly used in bridge applications in recent years, especially as auxiliary reinforcement in bridge I- and box beams and as primary reinforcement in slabs. Design for shear has traditionally not included a fatigue check of the reinforcement as the member is expected to be uncracked under service conditions and the stress range in steel minimal. The stress range for steel bars has existed in previous editions. It is based on Hansen et al. (1976). The simplified form in this edition replaces the (r/h) parameter with the default value 0.3 recommended by Hansen et al. Inclusion of limits for WWR is based on recent studies by Hawkins et al. (1971, 1987) and Tadros et al. (2004).

f_{min} = minimum live-load stress resulting from the Fatigue I load combination, combined with the more severe stress from either the permanent loads or the permanent loads, shrinkage, and creep-induced external loads; positive if tension, negative if compression (ksi)

The definition of the high-stress region for application of Eqs. 5.5.3.2-1 and 5.5.3.2-2 for flexural reinforcement shall be taken as one-third of the span on each side of the section of maximum moment.

5.5.3.3—Prestressing Tendons

The constant-amplitude fatigue threshold, $(\Delta F)_{TH}$, for prestressing tendons shall be taken as:

- 18.0 ksi for radii of curvature in excess of 30.0 ft, and
- 10.0 ksi for radii of curvature not exceeding 12.0 ft.

A linear interpolation may be used for radii between 12.0 and 30.0 ft.

5.5.3.4—Welded or Mechanical Splices of Reinforcement

For welded or mechanical connections that are subject to repetitive loads, the constant-amplitude fatigue threshold, $(\Delta F)_{TH}$, shall be as given in Table 5.5.3.4-1.

Table 5.5.3.4-1—Constant-Amplitude Fatigue Threshold of Splices

Type of Splice	$(\Delta F)_{TH}$ for greater than 1,000,000 cycles
Grout-filled sleeve, with or without epoxy coated bar	18 ksi
Cold-swaged coupling sleeves without threaded ends and with or without epoxy-coated bar; Integrally-forged coupler with upset NC threads; Steel sleeve with a wedge; One-piece taper-threaded coupler; and Single V-groove direct butt weld	12 ksi
All other types of splices	4 ksi

Where the total cycles of loading, N , as specified in Eq. 6.6.1.2.5-2, are less than one million, $(\Delta F)_{TH}$ in Table 5.5.3.4-1 may be increased by the quantity $24(6-\log N)$ ksi to a total not greater than the value given by Eq. 5.5.3.2-1 in Article 5.5.3.2. Higher values

Since the fatigue provisions were developed based primarily on ASTM A615 steel reinforcement, their applicability to other types of reinforcement is largely unknown. Consequently, a cautionary note is added to the Commentary.

C5.5.3.3

Where the radius of curvature is less than shown, or metal-to-metal fretting caused by prestressing tendons rubbing on hold-downs or deviations is apt to be a consideration, it will be necessary to consult the literature for more complete presentations that will allow the increased bending stress in the case of sharp curvature, or fretting, to be accounted for in the development of permissible fatigue stress ranges. Metal-to-metal fretting is not normally expected to be a concern in conventional pretensioned beams.

C5.5.3.4

Review of the available fatigue and static test data indicates that any splice, that develops 125 percent of the yield strength of the bar will sustain one million cycles of a 4 ksi constant amplitude stress range. This lower limit is a close lower bound for the splice fatigue data obtained in NCHRP Project 10-35, and it also agrees well with the limit of 4.5 ksi for Category E from the provisions for fatigue of structural steel weldments. The strength requirements of Articles 5.11.5.2.2 and 5.11.5.2.3 also will generally ensure that a welded splice or mechanical connector will also meet certain minimum requirements for fabrication and installation, such as sound welding and proper dimensional tolerances. Splices that do not meet these requirements for fabrication and installation may have reduced fatigue performance. Further, splices designed to the lesser force requirements of Article 5.11.5.3.2 may not have the same fatigue performance as splices designed for the greater force requirement. Consequently, the minimum strength requirement indirectly provides for a minimum fatigue performance.

It was found in NCHRP Project 10-35 that there is substantial variation in the fatigue performance of different types of welds and connectors. However, all types of splices appeared to exhibit a constant amplitude fatigue limit for repetitive loading exceeding about one million cycles. The stress ranges for over one million cycles of loading given in Table 5.5.3.4-1 are based on statistical tolerance limits to constant amplitude staircase test data, such that there is a 95 percent level of

of $(\Delta F)_{TH}$, up to the value given by Eq. 5.5.3.2-1, may be used if justified by fatigue test data on splices that are the same as those that will be placed in service.

Welded or mechanical splices shall not be used with ASTM A1035/A1035M reinforcement.

confidence that 95 percent of the data would exceed the given values for five million cycles of loading. These values may, therefore, be regarded as a fatigue limit below which fatigue damage is unlikely to occur during the design lifetime of the structure. This is the same basis used to establish the fatigue design provisions for unspliced reinforcing bars in Article 5.5.3.2, which is based on fatigue tests reported in NCHRP Report 164, *Fatigue Strength of High-Yield Reinforcing Bars*.

5.5.4—Strength Limit State

5.5.4.1—General

The strength limit state issues to be considered shall be those of strength and stability.

Factored resistance shall be the product of nominal resistance as determined in accordance with the applicable provisions of Articles 5.6, 5.7, 5.8, 5.9, 5.10, 5.13, and 5.14, unless another limit state is specifically identified, and the resistance factor is as specified in Article 5.5.4.2.

5.5.4.2—Resistance Factors

5.5.4.2.1—Conventional Construction

Resistance factor ϕ shall be taken as:

- For tension-controlled reinforced concrete sections as defined in Article 5.7.2.1 0.90
- For tension-controlled prestressed concrete sections as defined in Article 5.7.2.1 1.00
- For shear and torsion:
 - normal weight concrete 0.90
 - lightweight concrete 0.80
- For compression-controlled sections with spirals or ties, as defined in Article 5.7.2.1, except as specified in Articles 5.10.11.3 and 5.10.11.4.1b for Seismic Zones 2, 3, and 4 at the extreme event limit state 0.75
- For bearing on concrete 0.70
- For compression in strut-and-tie models 0.70

C5.5.4.1

Additional resistance factors are specified in Article 12.5.5 for buried pipes and box structures made of concrete.

C5.5.4.2.1

In applying the resistance factors for tension-controlled and compression-controlled sections, the axial tensions and compressions to be considered are those caused by external forces. Effects of primary prestressing forces are not included.

In editions of and interims to the LRFD Specifications prior to 2005, the provisions specified the magnitude of the resistance factor for cases of axial load or flexure, or both, in terms of the type of loading. For these cases, the ϕ -factor is now determined by the strain conditions at a cross-section, at nominal strength. The background and basis for these provisions are given in Mast (1992) and ACI 318-02.

A lower ϕ -factor is used for compression-controlled sections than is used for tension-controlled sections because compression-controlled sections have less ductility, are more sensitive to variations in concrete strength, and generally occur in members that support larger loaded areas than members with tension-controlled sections.

For sections subjected to axial load with flexure, factored resistances are determined by multiplying both P_n and M_n by the appropriate single value of ϕ . Compression-controlled and tension-controlled sections are defined in Article 5.7.2.1 as those that have net tensile strain in the extreme tension steel at nominal strength less than or equal to the compression-controlled strain limit, and equal to or greater than 0.005, respectively. For sections with net tensile strain ϵ_t in the extreme tension steel at nominal strength between the above limits, the value of ϕ may be determined by linear

interpolation, as shown in Figure C5.5.4.2.1-1. The concept of net tensile strain ϵ_t is discussed in Article C5.7.2.1. Classifying sections as tension-controlled, transition or compression-controlled, and linearly varying the resistance factor in the transition zone between reasonable values for the two extremes, provides a rational approach for determining ϕ and limiting the capacity of over-reinforced sections.

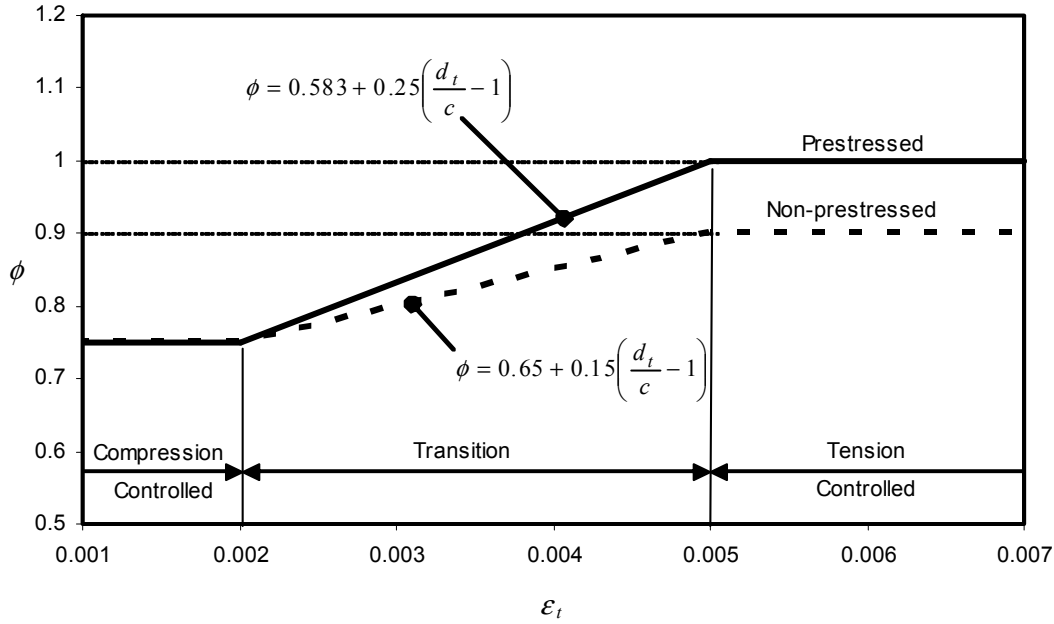

Figure C5.5.4.2.1-1—Variation of ϕ with Net Tensile Strain ϵ_t and d_t/c for Grade 60 Reinforcement and for Prestressing Steel

- For compression in anchorage zones:
 - normal weight concrete 0.80
 - lightweight concrete 0.65
- For tension in steel in anchorage zones 1.00
- For resistance during pile driving 1.00

For sections in which the net tensile strain in the extreme tension steel at nominal resistance is between the limits for compression-controlled and tension-controlled sections, ϕ may be linearly increased from 0.75 to that for tension-controlled sections as the net tensile strain in the extreme tension steel increases from the compression-controlled strain limit to 0.005.

This variation ϕ may be computed for prestressed members such that:

$$0.75 \leq \phi = 0.583 + 0.25 \left(\frac{d_t}{c} - 1 \right) \leq 1.0 \quad (5.5.4.2.1-1)$$

and for nonprestressed members such that:

$$0.75 \leq \phi = 0.65 + 0.15 \left(\frac{d_t}{c} - 1 \right) \leq 0.9 \quad (5.5.4.2.1-2)$$

The ϕ -factor of 0.8 for normal weight concrete reflects the importance of the anchorage zone, the brittle failure mode for compression struts in the anchorage zone, and the relatively wide scatter of results of experimental anchorage zone studies. The ϕ -factor of 0.65 for lightweight concrete reflects its often lower tensile strength and is based on the multipliers used in ACI 318-89, Section 11.2.1.2.

The design of intermediate anchorages, anchorages, diaphragms, and multiple slab anchorages are addressed in Breen et al. (1994).

The typical cross-section of a continuous concrete box girder often shows both conventional bar reinforcing and post-tensioning ducts. This superstructure, however, is first designed to satisfy the Service limit state by determining the number of tendons required to satisfy allowable stress limits. Then, the strength limit state is checked. Mild steel may or may not need to be added. If mild steel is required to satisfy the Strength but not the service limit state, the member is still considered fully prestressed for the purpose of determining the appropriate resistance factor.

where:

- c = distance from the extreme compression fiber to the neutral axis (in.)
- d_t = distance from the extreme compression fiber to the centroid of the extreme tension steel element (in.)

5.5.4.2.2—Segmental Construction

Resistance factors for the strength limit state shall be taken as provided in Table 5.5.4.2.2-1 for the conditions indicated and in Article 5.5.4.2.1 for conditions not covered in Table 5.5.4.2.2-1.

In selecting resistance factors for flexure, ϕ_f , and shear and torsion, ϕ_v , the degree of bonding of the post-tensioning system shall be considered. In order for a tendon to be considered as fully bonded at a section, it should be fully developed at that section for a development length not less than that required by Article 5.11.4. Shorter embedment lengths may be permitted if demonstrated by full-size tests and approved by the Engineer.

Where the post-tensioning is a combination of fully bonded tendons and unbonded or partially bonded tendons, the resistance factor at any section shall be based upon the bonding conditions for the tendons providing the majority of the prestressing force at the section.

Joints between precast units shall be either cast-in-place closures or match cast and epoxied joints.

Table 5.5.4.2.2-1—Resistance Factor for Joints in Segmental Construction

	ϕ_f Flexure	ϕ_v Shear
Normal Weight Concrete		
Fully Bonded Tendons	0.95	0.90
Unbonded or Partially Bonded Tendons	0.90	0.85
Sand-Lightweight Concrete		
Fully Bonded Tendons	0.90	0.70
Unbonded or Partially Bonded Tendons	0.85	0.65

5.5.4.2.3—Special Requirements for Seismic Zones 2, 3, and 4

A modified resistance factor for columns in Seismic Zones 2, 3, and 4 shall be taken as specified in Articles 5.10.11.3 and 5.10.11.4.1b.

C5.5.4.2.2

Comprehensive tests of a large continuous three-span model of a twin-cell box girder bridge built from precast segments with fully bonded internal tendons and epoxy joints indicated that cracking was well distributed through the segment lengths. No epoxy joint opened at failure, and the load deflection curve was identical to that calculated for a monolithic specimen. The complete ultimate strength of the tendons was developed at failure. The model had substantial ductility and full development of calculated deflection at failure. Flexural cracking concentrated at joints and final failure came when a central joint opened widely and crushing occurred at the top of the joint. Based on the observation of this limited test data, a maximum ϕ of 0.95 was selected.

5.5.4.3—Stability

The structure as a whole and its components shall be designed to resist sliding, overturning, uplift and buckling. Effects of eccentricity of loads shall be considered in the analysis and design.

Buckling of precast members during handling, transportation, and erection shall be investigated.

5.5.5—Extreme Event Limit State

The structure as a whole and its components shall be proportioned to resist collapse due to extreme events, specified in Table 3.4.1-1, as may be appropriate to its site and use.

5.6—DESIGN CONSIDERATIONS

5.6.1—General

Components and connections shall be designed to resist load combinations, as specified in Section 3, at all stages during the life of the structure, including those during construction. Load factors shall be as specified in Section 3.

As specified in Section 4, equilibrium and strain compatibility shall be maintained in the analysis.

5.6.2—Effects of Imposed Deformation

The effects of imposed deformations due to shrinkage, temperature change, creep, prestressing, and movements of supports shall be investigated.

5.6.3—Strut-and-Tie Model

5.6.3.1—General

Strut-and-tie models may be used to determine internal force effects near supports and the points of application of concentrated loads at strength and extreme event limit states.

The strut-and-tie model should be considered for the design of deep footings and pile caps or other situations in which the distance between the centers of applied load and the supporting reactions is less than about twice the member thickness.

C5.6.1

This Article reflects the AASHTO *Standard Specifications for Highway Bridges* (1996), the AASHTO *Guide Specifications for Design and Construction of Segmental Concrete Bridges* (1989) and the *Ontario Highway Bridge Design Code* (1991).

C5.6.2

For common structure types, experience may show that evaluating the redistribution of force effects as a result of creep and shrinkage is unnecessary.

C5.6.3.1

Where the conventional methods of strength of materials are not applicable because of nonlinear strain distribution, the strut-and-tie modeling may provide a convenient way of approximating load paths and force effects in the structure. In fact, the load paths may be visualized and the geometry of concrete and steel selected to implement the load path.

The strut-and-tie model is new to these Specifications. More detailed information on this method is given by Schlaich et al. (1987) and Collins and Mitchell (1991).

Traditional section-by-section design is based on the assumption that the reinforcement required at a particular section depends only on the separated values of the factored section force effects V_u , M_u , and T_u and does not consider the mechanical interaction among these force effects as the strut-and-tie model does. The traditional method further assumes that shear distribution remains uniform and that the longitudinal strains will vary linearly over the depth of the beam.

If the strut-and-tie model is selected for structural analysis, Articles 5.6.3.2 through 5.6.3.6 shall apply.

5.6.3.2—Structural Modeling

The structure and a component or region, thereof, may be modeled as an assembly of steel tension ties and concrete compressive struts interconnected at nodes to form a truss capable of carrying all the applied loads to the supports. The required widths of compression struts and tension ties shall be considered in determining the geometry of the truss.

The factored resistance, P_r , of struts and ties shall be taken as that of axially loaded components:

$$P_r = \phi P_n \quad (5.6.3.2-1)$$

where:

- P_n = nominal resistance of strut or tie (kip)
- ϕ = resistance factor for tension or compression specified in Article 5.5.4.2, as appropriate

For members such as the deep beam shown in Figure C5.6.3.2-1, these assumptions are not valid. The shear stresses on a section just to the right of a support will be concentrated near the bottom face. The behavior of a component, such as the deep beam, can be predicted more accurately if the flow of forces through the complete structure is studied. Instead of determining V_u and M_u at different sections along the span, the flow of compressive stresses going from the loads P to the supports and the required tension force to be developed between the supports should be established.

For additional applications of the strut-and-tie model see Articles 5.10.9.4, 5.13.2.3, and 5.13.2.4.1.

C5.6.3.2

Cracked reinforced concrete carries load principally by compressive stresses in the concrete and tensile stresses in the reinforcement. After significant cracking has occurred, the principal compressive stress trajectories in the concrete tend toward straight lines and hence can be approximated by straight compressive struts. Tension ties are used to model the principal reinforcement.

A strut-and-tie truss model is shown in Figures C5.6.3.2-1 and C5.6.3.2-2. The zones of high unidirectional compressive stress in the concrete are represented by compressive struts. The regions of the concrete subjected to multidirectional stresses, where the struts and ties meet the joints of the truss, are represented by nodal zones.

Because of the significant transverse dimensions of the struts and ties, a “truss joint” becomes a “nodal zone” with finite dimensions. Establishing the geometry of the truss usually involves trial and error in which member sizes are assumed, the truss geometry is established, member forces are determined, and the assumed member sizes are verified.

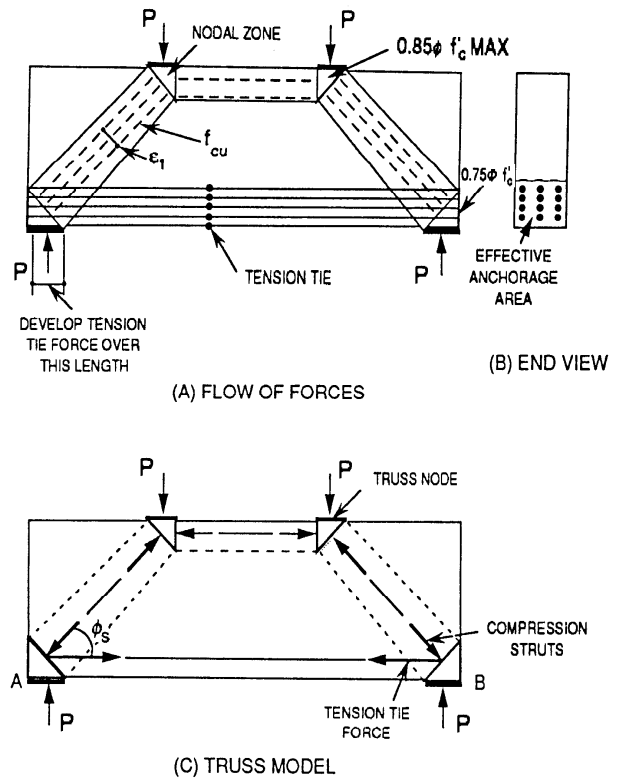

Figure C5.6.3.2-1—Strut-and-Tie Model for a Deep Beam

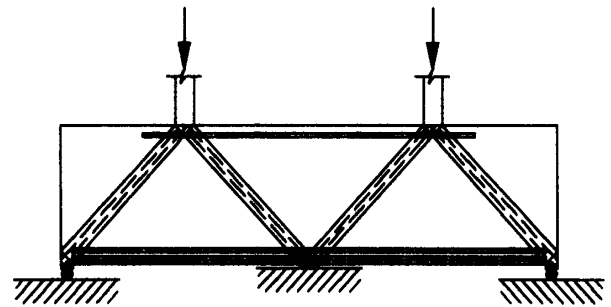

Figure C5.6.3.2-2—Strut-and-Tie Model for Continuous Deep Beam

5.6.3.3—Proportioning of Compressive Struts

5.6.3.3.1—Strength of Unreinforced Strut

The nominal resistance of an unreinforced compressive strut shall be taken as:

$$P_n = f_{cu} A_{cs} \quad (5.6.3.3.1-1)$$

where:

- P_n = nominal resistance of a compressive strut (kip)
- f_{cu} = limiting compressive stress as specified in Article 5.6.3.3.3 (ksi)
- A_{cs} = effective cross-sectional area of strut as specified in Article 5.6.3.3.2 (in.²)

5.6.3.3.2—Effective Cross-Sectional Area of Strut

The value of A_{cs} shall be determined by considering both the available concrete area and the anchorage conditions at the ends of the strut, as shown in Figure 5.6.3.3.2-1.

When a strut is anchored by reinforcement, the effective concrete area may be considered to extend a distance of up to six bar diameters from the anchored bar, as shown in Figure 5.6.3.3.2-1 (a).

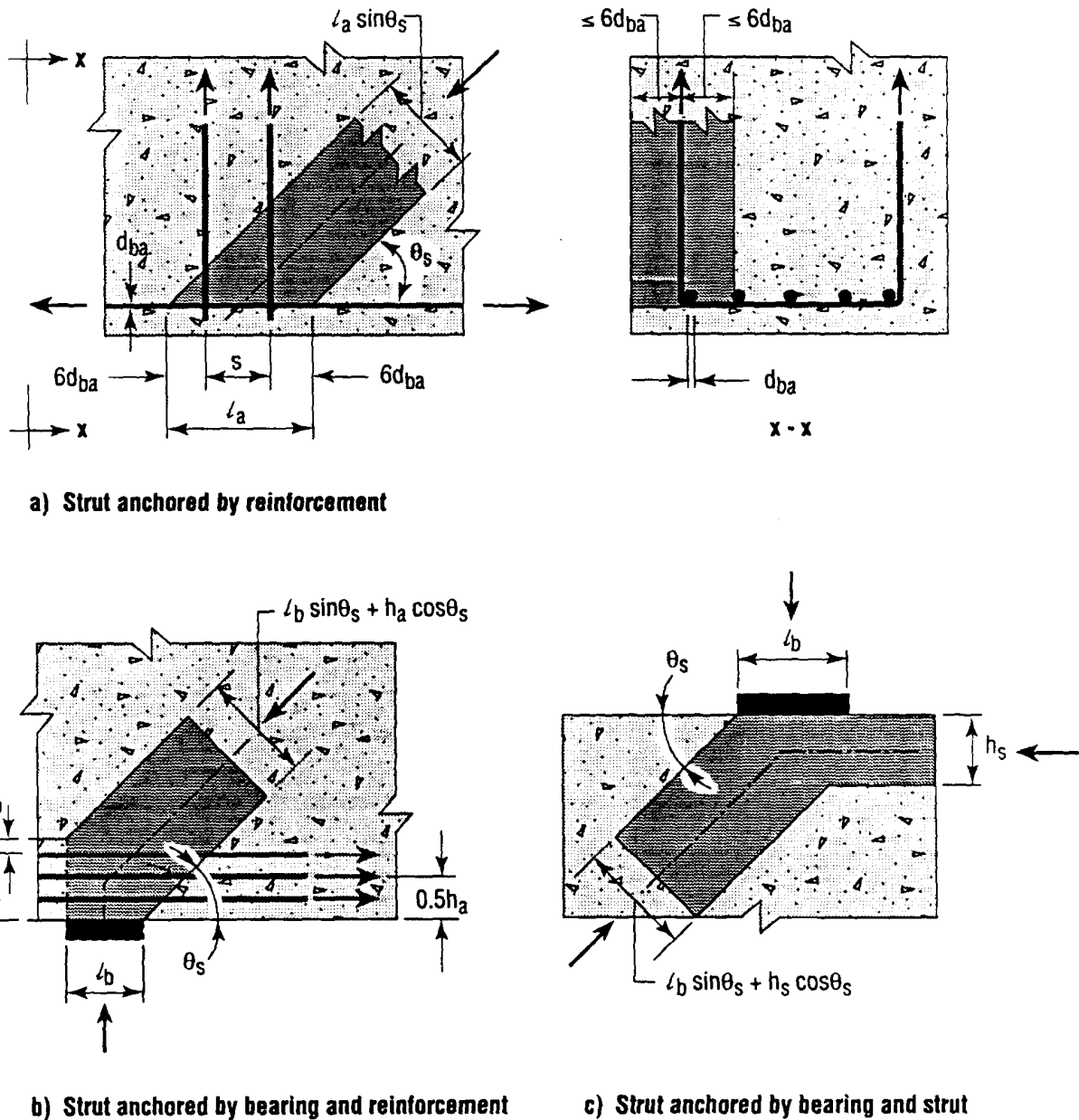

Figure 5.6.3.3.2-1—Influence of Anchorage Conditions on Effective Cross-Sectional Area of Strut

5.6.3.3.3—Limiting Compressive Stress in Strut

The limiting compressive stress, f_{cu} , shall be taken as:

$$f_{cu} = \frac{f'_c}{0.8 + 170\varepsilon_1} \leq 0.85 f'_c \quad (5.6.3.3.3-1)$$

in which:

$$\varepsilon_1 = \varepsilon_s + (\varepsilon_s + 0.002) \cot^2 \alpha_s \quad (5.6.3.3.3-2)$$

where:

- α_s = the smallest angle between the compressive strut and adjoining tension ties (degrees)
- ε_s = the tensile strain in the concrete in the direction of the tension tie (in./in.)
- f'_c = specified compressive strength (ksi)

5.6.3.3.4—Reinforced Strut

If the compressive strut contains reinforcement that is parallel to the strut and detailed to develop its yield stress in compression, the nominal resistance of the strut shall be taken as:

$$P_n = f_{cu} A_{cs} + f_y A_{ss} \quad (5.6.3.3.4-1)$$

where:

- A_{ss} = area of reinforcement in the strut (in.²)

5.6.3.4—Proportioning of Tension Ties

5.6.3.4.1—Strength of Tie

Tension tie reinforcement shall be anchored to the nodal zones by specified embedment lengths, hooks, or mechanical anchorages. The tension force shall be developed at the inner face of the nodal zone.

The nominal resistance of a tension tie in kips shall be taken as:

$$P_n = f_y A_{st} + A_{ps} [f_{pe} + f_y] \quad (5.6.3.4.1-1)$$

where:

C5.6.3.3.3

If the concrete is not subjected to principal tensile strains greater than about 0.002, it can resist a compressive stress of $0.85 f'_c$. This will be the limit for regions of the struts not crossed by or joined to tension ties. The reinforcing bars of a tension tie are bonded to the surrounding concrete. If the reinforcing bars are to yield in tension, there should be significant tensile strains imposed on the concrete. As these tensile strains increase, f_{cu} decreases.

The expression for ε_1 is based on the assumption that the principal compressive strain ε_2 in the direction of the strut equals 0.002 and that the tensile strain in the direction of the tension tie equals ε_s . As the angle between the strut-and-tie decreases, ε_1 increases and hence f_{cu} decreases. In the limit, no compressive stresses would be permitted in a strut that is superimposed on a tension tie, i.e., $\alpha_s = 0$, a situation that violates compatibility.

For a tension tie consisting of reinforcing bars, ε_s can be taken as the tensile strain due to factored loads in the reinforcing bars. For a tension tie consisting of prestressing, ε_s can be taken as 0.0 until the precompression of the concrete is overcome. For higher stresses, ε_s would equal $(f_{ps} - f_{pe})/E_p$.

If the strain ε_s varies over the width of the strut, it is appropriate to use the value at the centerline of the strut.

C5.6.3.4.1

The second term of the equation for P_n is intended to ensure that the prestressing steel does not reach its yield point, thus a measure of control over unlimited cracking is maintained. It does, however, acknowledge that the stress in the prestressing elements will be increased due to the strain that will cause the concrete to crack. The increase in stress corresponding to this action is arbitrarily limited to the same increase in stress that the mild steel will undergo. If there is no mild steel, f_y may be taken as 60.0 ksi for the second term of the equation.

- A_{st} = total area of longitudinal mild steel reinforcement in the tie (in.²)
 A_{ps} = area of prestressing steel (in.²)
 f_y = yield strength of mild steel longitudinal reinforcement (ksi)
 f_{pe} = stress in prestressing steel due to prestress after losses (ksi)

5.6.3.4.2—Anchorage of Tie

The tension tie reinforcement shall be anchored to transfer the tension force therein to the node regions of the truss in accordance with the requirements for development of reinforcement as specified in Article 5.11.

5.6.3.5—Proportioning of Node Regions

Unless confining reinforcement is provided and its effect is supported by analysis or experimentation, the concrete compressive stress in the node regions of the strut shall not exceed:

- For node regions bounded by compressive struts and bearing areas: $0.85\phi f'_c$
- For node regions anchoring a one-direction tension tie: $0.75\phi f'_c$
- For node regions anchoring tension ties in more than one direction: $0.65\phi f'_c$

where:

- ϕ = the resistance factor for bearing on concrete as specified in Article 5.5.4.2.

The tension tie reinforcement shall be uniformly distributed over an effective area of concrete at least equal to the tension tie force divided by the stress limits specified herein.

In addition to satisfying strength criteria for compression struts and tension ties, the node regions shall be designed to comply with the stress and anchorage limits specified in Articles 5.6.3.4.1 and 5.6.3.4.2.

The bearing stress on the node region produced by concentrated loads or reaction forces shall satisfy the requirements specified in Article 5.7.5.

5.6.3.6—Crack Control Reinforcement

Structures and components or regions thereof, except for slabs and footings, which have been designed in accordance with the provisions of Article 5.6.3, shall contain orthogonal grids of reinforcing bars. The spacing of the bars in these grids shall not exceed the smaller of $d/4$ and 12.0 in.

The reinforcement in the vertical and horizontal direction shall satisfy the following:

C5.6.3.5

The limits in concrete compressive stresses in nodal zones are related to the degree of expected confinement in these zones provided by the concrete in compression.

The stresses in the nodal zones can be reduced by increasing the:

- Size of the bearing plates,
- Dimensions of the compressive struts, and
- Dimensions of the tension ties.

The reduced stress limits on nodes anchoring tension ties are based on the detrimental effect of the tensile straining caused by these ties. If the ties consist of post-tensioned tendons and the stress in the concrete does not need to be above f_{pe} , no tensile straining of the nodal zone will be required. For this case, the $0.85\phi f'_c$ limit is appropriate.

C5.6.3.6

This reinforcement is intended to control the width of cracks and to ensure a minimum ductility for the member so that, if required, significant redistribution of internal stresses is possible.

The total horizontal reinforcement can be calculated as 0.003 times the effective area of the strut denoted by the shaded portion of the cross-section in Figure C5.6.3.6-1. For thinner members, this crack

$$\frac{A_v}{b_w s_v} \geq 0.003 \quad (5.6.3.6-1)$$

$$\frac{A_h}{b_w s_h} \geq 0.003 \quad (5.6.3.6-2)$$

where:

A_h = total area of horizontal crack control reinforcement within spacing s_h , respectively (in.²)

A_v = total area of vertical crack control reinforcement within spacing s_v , respectively (in.²)

b_w = width of member's web (in.)

s_v, s_h = spacing of vertical and horizontal crack control reinforcement, respectively (in.)

Crack control reinforcement shall be distributed evenly within the strut area.

control reinforcement will consist of two grids of reinforcing bars, one near each face. For thicker members, multiple grids of reinforcement through the thickness may be required in order to achieve a practical layout.

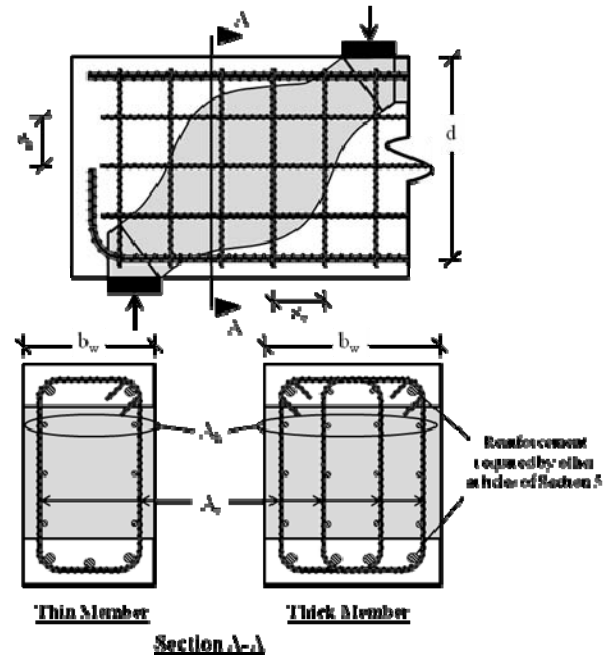

Figure C5.6.3.6-1—Distribution of Crack Control Reinforcement in Compression Strut

5.7—DESIGN FOR FLEXURAL AND AXIAL FORCE EFFECTS

5.7.1—Assumptions for Service and Fatigue Limit States

The following assumptions may be used in the design of reinforced, prestressed, and partially prestressed concrete components for all compressive strength levels:

- Prestressed concrete resists tension at sections that are uncracked, except as specified in Article 5.7.6.
- The strains in the concrete vary linearly, except in components or regions of components for which conventional strength of materials is inappropriate.
- The modular ratio, n , is rounded to the nearest integer number.
- The modular ratio is calculated as follows:
 - E_s/E_c for reinforcing bars
 - E_p/E_c for prestressing tendons
- An effective modular ratio of $2n$ is applicable to permanent loads and prestress.

C5.7.1

Prestressing is treated as part of resistance, except for anchorages and similar details, where the design is totally a function of the tendon force and for which a load factor is specified in Article 3.4.3. External reactions caused by prestressing induce force effects that normally are taken to be part of the loads side of Eq. 1.3.2.1-1. This represents a philosophical dichotomy. In lieu of more precise information, in these Specifications the load factor for these induced force effects should be taken as that for the permanent loads.

Examples of components for which the assumption of linearly varying strains may not be suitable include deep components such as deep beams, corbels, and brackets.

5.7.2—Assumptions for Strength and Extreme Event Limit States

5.7.2.1—General

Factored resistance of concrete components shall be based on the conditions of equilibrium and strain compatibility, the resistance factors as specified in Article 5.5.4.2, and the following assumptions:

- In components with fully bonded reinforcement or prestressing, or in the bonded length of locally debonded or shielded strands, strain is directly proportional to the distance from the neutral axis, except for deep members that shall satisfy the requirements of Article 5.13.2, and for other disturbed regions.
- In components with fully unbonded or partially unbonded prestressing tendons, i.e., not locally debonded or shielded strands, the difference in strain between the tendons and the concrete section and the effect of deflections on tendon geometry are included in the determination of the stress in the tendons.
- If the concrete is unconfined, the maximum usable strain at the extreme concrete compression fiber is not greater than 0.003.
- If the concrete is confined, a maximum usable strain exceeding 0.003 in the confined core may be utilized if verified. Calculation of the factored resistance shall consider that the concrete cover may be lost at strains compatible with those in the confined concrete core.
- Except for the strut-and-tie model, the stress in the reinforcement is based on a stress-strain curve representative of the steel or on an approved mathematical representation, including development of reinforcing and prestressing elements and transfer of pretensioning.
- The tensile strength of the concrete is neglected.
- The concrete compressive stress-strain distribution is assumed to be rectangular, parabolic, or any other shape that results in a prediction of strength in substantial agreement with the test results.
- The development of reinforcing and prestressing elements and transfer of pretensioning are considered.
- Balanced strain conditions exist at a cross-section when tension reinforcement reaches the strain corresponding to its specified yield strength f_y , just as the concrete in compression reaches its assumed ultimate strain of 0.003.

C5.7.2.1

The first paragraph of C5.7.1 applies.

Research by Bae and Bayrak (2003) has shown that, for well-confined High Strength Concrete (HSC) columns, the concrete cover may be lost at maximum useable strains at the extreme concrete compression fiber as low as 0.0022. The heavy confinement steel causes a weak plane between the concrete core and cover, causing high shear stresses and the resulting early loss of concrete cover.

The nominal flexural strength of a member is reached when the strain in the extreme compression fiber reaches the assumed strain limit of 0.003. The net tensile strain ϵ_t is the tensile strain in the extreme tension steel at nominal strength, exclusive of strains due to

- Sections are compression-controlled when the net tensile strain in the extreme tension steel is equal to or less than the compression-controlled strain limit at the time the concrete in compression reaches its assumed strain limit of 0.003. The compression-controlled strain limit is the net tensile strain in the reinforcement at balanced strain conditions. For Grade 60 reinforcement, and for all prestressed reinforcement, the compression-controlled strain limit may be set equal to 0.002.

prestress, creep, shrinkage, and temperature. The net tensile strain in the extreme tension steel is determined from a linear strain distribution at nominal strength, as shown in Figure C5.7.2.1-1, using similar triangles.

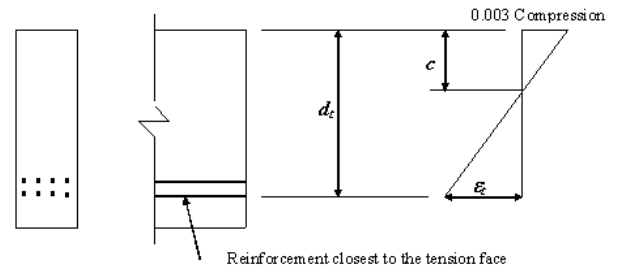

Figure C5.7.2.1-1—Strain Distribution and Net Tensile Strain

- Sections are tension-controlled when the net tensile strain in the extreme tension steel is equal to or greater than 0.005 just as the concrete in compression reaches its assumed strain limit of 0.003. Sections with net tensile strain in the extreme tension steel between the compression-controlled strain limit and 0.005 constitute a transition region between compression-controlled and tension-controlled sections.
- The use of compression reinforcement in conjunction with additional tension reinforcement is permitted to increase the strength of flexural members.

When the net tensile strain in the extreme tension steel is sufficiently large (equal to or greater than 0.005), the section is defined as tension-controlled where ample warning of failure with excessive deflection and cracking may be expected. When the net tensile strain in the extreme tension steel is small (less than or equal to the compression-controlled strain limit), a brittle failure condition may be expected, with little warning of impending failure. Flexural members are usually tension-controlled, while compression members are usually compression-controlled. Some sections, such as those with small axial load and large bending moment, will have net tensile strain in the extreme tension steel between the above limits. These sections are in a transition region between compression- and tension-controlled sections. Article 5.5.4.2.1 specifies the appropriate resistance factors for tension-controlled and compression-controlled sections, and for intermediate cases in the transition region.

Before the development of these provisions, the limiting tensile strain for flexural members was not stated, but was implicit in the maximum reinforcement limit that was given as $c/d_e \leq 0.42$, which corresponded to a net tensile strain at the centroid of the tension reinforcement of 0.00414. The net tensile strain limit of 0.005 for tension-controlled sections was chosen to be a single value that applies to all types of steel (prestressed and nonprestressed) permitted by this Specification.

Unless unusual amounts of ductility are required, the 0.005 limit will provide ductile behavior for most designs. One condition where greater ductile behavior is required is in design for redistribution of moments in continuous members and frames. Article 5.7.3.5 permits redistribution of negative moments. Since moment redistribution is dependent on adequate ductility in hinge regions, moment redistribution is limited to sections that have a net tensile strain of at least 0.0075.

For beams with compression reinforcement, or T-beams, the effects of compression reinforcement and flanges are automatically accounted for in the computation of net tensile strain ϵ_t .

- In the approximate flexural resistance equations of Articles 5.7.3.1 and 5.7.3.2, f_y and f'_y may replace f_s and f'_s , respectively, subject to the following conditions:
 - f_y may replace f_s when, using f_y in the calculation, the resulting ratio c/d_s does not exceed 0.6. If c/d_s exceeds 0.6, strain compatibility shall be used to determine the stress in the mild steel tension reinforcement.
 - f'_y may replace f'_s when, using f'_y in the calculation, $c \geq 3d'_s$. If $c < 3d'_s$, strain compatibility shall be used to determine the stress in the mild steel compression reinforcement. The compression reinforcement shall be conservatively ignored, i.e., $A'_s = 0$.

Additional limitations on the maximum usable extreme concrete compressive strain in hollow rectangular compression members shall be investigated as specified in Article 5.7.4.7.

5.7.2.2—Rectangular Stress Distribution

The natural relationship between concrete stress and strain may be considered satisfied by an equivalent rectangular concrete compressive stress block of $0.85f'_c$ over a zone bounded by the edges of the cross-section and a straight line located parallel to the neutral axis at the distance $a = \beta_1 c$ from the extreme compression fiber. The distance c shall be measured perpendicular to the neutral axis. The factor β_1 shall be taken as 0.85 for concrete strengths not exceeding 4.0 ksi. For concrete strengths exceeding 4.0 ksi, β_1 shall be reduced at a rate of 0.05 for each 1.0 ksi of strength in excess of 4.0 ksi, except that β_1 shall not be taken to be less than 0.65.

Additional limitations on the use of the rectangular stress block when applied to hollow rectangular compression members shall be investigated as specified in Article 5.7.4.7.

When using the approximate flexural resistance equations in Articles 5.7.3.1 and 5.7.3.2, it is important to assure that both the tension and compression mild steel reinforcement are yielding to obtain accurate results. In previous editions of the *AASHTO LRFD Bridge Design Specifications*, the maximum reinforcement limit of $c/d_e \leq 0.42$ assured that the mild tension steel would yield at nominal flexural resistance, but this limit was eliminated in the 2006 interim revisions. The current limit of $c/d_s \leq 0.6$ assures that the mild tension steel will be at or near yield, while $c \geq 3d'_s$ assures that the mild compression steel will yield. It is conservative to ignore the compression steel when calculating flexural resistance. In cases where either the tension or compression steel does not yield, it is more accurate to use a method based on the conditions of equilibrium and strain compatibility to determine the flexural resistance.

The mild steel tension reinforcement limitation does not apply to prestressing steel used as tension reinforcement. The equations used to determine the stress in the prestressing steel at nominal flexural resistance already consider the effect of the depth to the neutral axis.

C5.7.2.2

For practical design, the rectangular compressive stress distribution defined in this Article may be used in lieu of a more exact concrete stress distribution. This rectangular stress distribution does not represent the actual stress distribution in the compression zone at ultimate, but in many practical cases it does provide essentially the same results as those obtained in tests. All strength equations presented in Article 5.7.3 are based on the rectangular stress block.

The factor β_1 is basically related to rectangular sections; however, for flanged sections in which the neutral axis is in the web, β_1 has experimentally been found to be an adequate approximation.

For sections that consist of a beam with a composite slab of different concrete strength, and the compression block includes both types of concrete, it is conservative to assume the composite beam to be of uniform strength at the lower of the concrete strengths in the flange and web. If a more refined estimate of flexural capacity is warranted, a more rigorous analysis method should be used. Examples of such analytical techniques are presented in Weigel, Seguirant, Brice, and Khaleghi (2003) and Seguirant, Brice, and Khaleghi (2004).

5.7.3—Flexural Members

5.7.3.1—Stress in Prestressing Steel at Nominal Flexural Resistance

5.7.3.1.1—Components with Bonded Tendons

C5.7.3.1.1

For rectangular or flanged sections subjected to flexure about one axis where the approximate stress distribution specified in Article 5.7.2.2 is used and for which f_{pe} is not less than $0.5 f_{pu}$, the average stress in prestressing steel, f_{ps} , may be taken as:

$$f_{ps} = f_{pu} \left(1 - k \frac{c}{d_p} \right) \tag{5.7.3.1.1-1}$$

in which:

$$k = 2 \left(1.04 - \frac{f_{py}}{f_{pu}} \right) \tag{5.7.3.1.1-2}$$

for T-section behavior:

$$c = \frac{A_{ps}f_{pu} + A_s f_s - A'_s f'_s - 0.85 f'_c (b - b_w) h_f}{0.85 f'_c \beta_1 b_w + k A_{ps} \frac{f_{pu}}{d_p}} \tag{5.7.3.1.1-3}$$

for rectangular section behavior:

$$c = \frac{A_{ps}f_{pu} + A_s f_s - A'_s f'_s}{0.85 f'_c \beta_1 b + k A_{ps} \frac{f_{pu}}{d_p}} \tag{5.7.3.1.1-4}$$

where:

- A_{ps} = area of prestressing steel (in.²)
- f_{pu} = specified tensile strength of prestressing steel (ksi)
- f_{py} = yield strength of prestressing steel (ksi)
- A_s = area of mild steel tension reinforcement (in.²)
- A'_s = area of compression reinforcement (in.²)
- f_s = stress in the mild steel tension reinforcement at nominal flexural resistance (ksi), as specified in Article 5.7.2.1
- f'_s = stress in the mild steel compression reinforcement at nominal flexural resistance (ksi), as specified in Article 5.7.2.1
- b = width of the compression face of the member; for a flange section in compression, the effective width of the flange as specified in Article 4.6.2.6 (in.)
- b_w = width of web (in.)
- h_f = depth of compression flange (in.)
- d_p = distance from extreme compression fiber to the centroid of the prestressing tendons (in.)

Equations in this Article and subsequent equations for flexural resistance are based on the assumption that the distribution of steel is such that it is reasonable to consider all of the tensile reinforcement to be lumped at the location defined by d_s and all of the prestressing steel can be considered to be lumped at the location defined by d_p . Therefore, in the case where a significant number of prestressing elements are on the compression side of the neutral axis, it is more appropriate to use a method based on the conditions of equilibrium and strain compatibility as indicated in Article 5.7.2.1.

The background and basis for Eqs. 5.7.3.1.1-1 and 5.7.3.1.2-1 can be found in Naaman (1985), Loov (1988), Naaman (1989), and Naaman (1990–1992).

Values of f_{py}/f_{pu} are defined in Table C5.7.3.1.1-1. Therefore, the values of k from Eq. 5.7.3.1.1-2 depend only on the type of tendon used.

Table C5.7.3.1.1-1—Values of k

Type of Tendon	f_{py}/f_{pu}	Value of k
Low relaxation strand	0.90	0.28
Stress-relieved strand and Type 1 high-strength bar	0.85	0.38
Type 2 high-strength bar	0.80	0.48

- c = distance between the neutral axis and the compressive face (in.)
- β_1 = stress block factor specified in Article 5.7.2.2

5.7.3.1.2—Components with Unbonded Tendons

For rectangular or flanged sections subjected to flexure about one axis and for biaxial flexure with axial load as specified in Article 5.7.4.5, where the approximate stress distribution specified in Article 5.7.2.2 is used, the average stress in unbonded prestressing steel may be taken as:

$$f_{ps} = f_{pe} + 900 \left(\frac{d_p - c}{\ell_e} \right) \leq f_{py} \quad (5.7.3.1.2-1)$$

in which:

$$\ell_e = \left(\frac{2 \ell_i}{2 + N_s} \right) \quad (5.7.3.1.2-2)$$

for T-section behavior:

$$c = \frac{A_{ps} f_{ps} + A_s f_s - A'_s f'_s - 0.85 f'_c (b - b_w) h_f}{0.85 f'_c \beta_1 b_w} \quad (5.7.3.1.2-3)$$

for rectangular section behavior:

$$c = \frac{A_{ps} f_{ps} + A_s f_s - A'_s f'_s}{0.85 f'_c \beta_1 b} \quad (5.7.3.1.2-4)$$

where:

- c = distance from extreme compression fiber to the neutral axis assuming the tendon prestressing steel has yielded, given by Eqs. 5.7.3.1.2-3 and 5.7.3.1.2-4 for T-section behavior and rectangular section behavior, respectively (in.)
- ℓ_e = effective tendon length (in.)
- ℓ_i = length of tendon between anchorages (in.)
- N_s = number of support hinges crossed by the tendon between anchorages or discretely bonded points
- f_{py} = yield strength of prestressing steel (ksi)
- f_{pe} = effective stress in prestressing steel at section under consideration after all losses (ksi)

5.7.3.1.3—Components with Both Bonded and Unbonded Tendons

5.7.3.1.3a—Detailed Analysis

Except as specified in Article 5.7.3.1.3b, for components with both bonded and unbonded tendons, the stress in the prestressing steel shall be computed by detailed analysis. This analysis shall take into account the strain compatibility between the section and the bonded prestressing steel. The stress in the unbonded prestressing

C5.7.3.1.2

A first estimate of the average stress in unbonded prestressing steel may be made as:

$$f_{ps} = f_{pe} + 15.0 \text{ (ksi)} \quad (C5.7.3.1.2-1)$$

In order to solve for the value of f_{ps} in Eq. 5.7.3.1.2-1, the equation of force equilibrium at ultimate is needed. Thus, two equations with two unknowns (f_{ps} and c) need to be solved simultaneously to achieve a closed-form solution.

steel shall take into account the global displacement compatibility between bonded sections of tendons located within the span. Bonded sections of unbonded tendons may be anchorage points and any bonded section, such as deviators. Consideration of the possible slip at deviators shall be taken into consideration. The nominal flexural strength should be computed directly from the stresses resulting from this analysis.

5.7.3.1.3b—Simplified Analysis

In lieu of the detailed analysis described in Article 5.7.3.1.3a, the stress in the unbonded tendons may be conservatively taken as the effective stress in the prestressing steel after losses, f_{pe} . In this case, the stress in the bonded prestressing steel shall be computed using Eqs. 5.7.3.1.1-1 through 5.7.3.1.1-4, with the term $A_{ps}f_{pu}$ in Eqs. 5.7.3.1.1-3 and 5.7.3.1.1-4 replaced with the term $A_{psb}f_{pu} + A_{psu}f_{pe}$.

where:

$$A_{psb} = \text{area of bonded prestressing steel (in.}^2\text{)}$$

$$A_{psu} = \text{area of unbonded prestressing steel (in.}^2\text{)}$$

When computing the nominal flexural resistance using Eq. 5.7.3.2.2-1, the average stress in the prestressing steel shall be taken as the weighted average of the stress in the bonded and unbonded prestressing steel, and the total area of bonded and unbonded prestressing shall be used.

5.7.3.2—Flexural Resistance

5.7.3.2.1—Factored Flexural Resistance

The factored resistance M_r shall be taken as:

$$M_r = \phi M_n \quad (5.7.3.2.1-1)$$

where:

$$M_n = \text{nominal resistance (kip-in.)}$$

$$\phi = \text{resistance factor as specified in Article 5.5.4.2}$$

5.7.3.2.2—Flanged Sections

For flanged sections subjected to flexure about one axis and for biaxial flexure with axial load as specified in Article 5.7.4.5, where the approximate stress distribution specified in Article 5.7.2.2 is used and where the compression flange depth is less than $a = \beta_1 c$, as determined in accordance with Eqs. 5.7.3.1.1-3, 5.7.3.1.1-4, 5.7.3.1.2-3, or 5.7.3.1.2-4, the nominal flexural resistance may be taken as:

C5.7.3.2.1

Moment at the face of the support may be used for design. Where fillets making an angle of 45 degrees or more with the axis of a continuous or restrained member are built monolithic with the member and support, the face of support should be considered at a section where the combined depth of the member and fillet is at least one and one-half times the thickness of the member. No portion of a fillet should be considered as adding to the effective depth when determining the nominal resistance.

C5.7.3.2.2

In previous editions and interims of the LRFD Specifications, the factor β_1 was applied to the flange overhang term of Eqs. 5.7.3.2.2-1, 5.7.3.1.1-3, and 5.7.3.1.2-3. This was not consistent with the original derivation of the equivalent rectangular stress block as it applies to flanged sections (Mattock, Kriz, and Hognestad. 1961). For the current LRFD Specifications, the β_1 factor has been removed from the flange overhang term of these equations. See also Seguirant (2002),

$$M_n = A_{ps} f_{ps} \left(d_p - \frac{a}{2} \right) + A_s f_s \left(d_s - \frac{a}{2} \right) - A'_s f'_s \left(d'_s - \frac{a}{2} \right) + 0.85 f'_c (b - b_w) h_f \left(\frac{a}{2} - \frac{h_f}{2} \right)$$

(5.7.3.2.2-1)

Girgis, Sun, and Tadros (2002), Naaman (2002), Weigel, Seguirant, Brice, and Khaleghi (2003), Baran, Schultz, and French (2004), and Seguirant, Brice, and Khaleghi (2004).

where:

- A_{ps} = area of prestressing steel (in.²)
- f_{ps} = average stress in prestressing steel at nominal bending resistance specified in Eq. 5.7.3.1.1-1 (ksi)
- d_p = distance from extreme compression fiber to the centroid of prestressing tendons (in.)
- A_s = area of nonprestressed tension reinforcement (in.²)
- f_s = stress in the mild steel tension reinforcement at nominal flexural resistance (ksi), as specified in Article 5.7.2.1
- d_s = distance from extreme compression fiber to the centroid of nonprestressed tensile reinforcement (in.)
- A'_s = area of compression reinforcement (in.²)
- f'_s = stress in the mild steel compression reinforcement at nominal flexural resistance (ksi), as specified in Article 5.7.2.1
- d'_s = distance from extreme compression fiber to the centroid of compression reinforcement (in.)
- f'_c = specified compressive strength of concrete at 28 days, unless another age is specified (ksi)
- b = width of the compression face of the member; for a flange section in compression, the effective width of the flange as specified in Article 4.6.2.6 (in.)
- b_w = web width or diameter of a circular section (in.)
- β_1 = stress block factor specified in Article 5.7.2.2
- h_f = compression flange depth of an I or T member (in.)
- a = $c\beta_1$; depth of the equivalent stress block (in.)

5.7.3.2.3—Rectangular Sections

For rectangular sections subjected to flexure about one axis and for biaxial flexure with axial load as specified in Article 5.7.4.5, where the approximate stress distribution specified in Article 5.7.2.2 is used and where the compression flange depth is not less than $a = \beta_1 c$ as determined in accordance with Eqs. 5.7.3.1.1-4 or 5.7.3.1.2-4, the nominal flexural resistance M_n may be determined by using Eqs. 5.7.3.1.1-1 through 5.7.3.2.2-1, in which case b_w shall be taken as b .

5.7.3.2.4—Other Cross-Sections

For cross-sections other than flanged or essentially rectangular sections with vertical axis of symmetry or for sections subjected to biaxial flexure without axial load, the nominal flexural resistance, M_n , shall be determined by an analysis based on the assumptions specified in Article 5.7.2. The requirements of Article 5.7.3.3 shall apply.

5.7.3.2.5—Strain Compatibility Approach

Alternatively, the strain compatibility approach may be used if more precise calculations are required. The appropriate provisions of Article 5.7.2.1 shall apply.

The stress and corresponding strain in any given layer of reinforcement may be taken from any representative stress-strain formula or graph for mild reinforcement and prestressing strands.

5.7.3.3—Limits for Reinforcement

5.7.3.3.1—Maximum Reinforcement

[PROVISION DELETED IN 2005]

C5.7.3.3.1

In editions of and interims to the LRFD Specifications prior to 2005, Article 5.7.3.3.1 limited the tension reinforcement quantity to a maximum amount such that the ratio c/d_e did not exceed 0.42. Sections with $c/d_e > 0.42$ were considered over-reinforced. Over-reinforced nonprestressed members were not allowed, whereas prestressed and partially prestressed members with PPR greater than 50 percent were if “it is shown by analysis and experimentation that sufficient ductility of the structure can be achieved.” No guidance was given for what “sufficient ductility” should be, and it was not clear what value of ϕ should be used for such over-reinforced members.

The current provisions of LRFD eliminate this limit and unify the design of prestressed and nonprestressed tension- and compression-controlled members. The background and basis for these provisions are given in Mast (1992). Below a net tensile strain in the extreme tension steel of 0.005, as the tension reinforcement quantity increases, the factored resistance of prestressed and nonprestressed sections is reduced in accordance with Article 5.5.4.2.1. This reduction compensates for decreasing ductility with increasing overstrength. Only the addition of compression reinforcement in conjunction with additional tension reinforcement can result in an increase in the factored flexural resistance of the section.

5.7.3.3.2 Minimum Reinforcement

Unless otherwise specified, at any section of a noncompression-controlled flexural component, the amount of prestressed and nonprestressed tensile reinforcement shall be adequate to develop a factored flexural resistance, M_r , at least equal to the lesser of:

C5.7.3.3.2

Minimum reinforcement provisions are intended to reduce the probability of brittle failure by providing flexural capacity greater than the cracking moment. Testing of a large number of lightly reinforced and prestressed concrete members at the University of

- 1.33 times the factored moment required by the applicable strength load combination specified in Table 3.4.1-1; and

$$M_{cr} = \gamma_3 \left[(\gamma_1 f_r + \gamma_2 f_{cpe}) S_c - M_{dnc} \left(\frac{S_c}{S_{nc}} - 1 \right) \right] \quad (5.7.3.3.2-1)$$

where:

- f_r = modulus of rupture of concrete specified in Article 5.4.2.6
- f_{cpe} = compressive stress in concrete due to effective prestress forces only (after allowance for all prestress losses) at extreme fiber of section where tensile stress is caused by externally applied loads (ksi)
- M_{dnc} = total unfactored dead load moment acting on the monolithic or noncomposite section (kip-in.)
- S_c = section modulus for the extreme fiber of the composite section where tensile stress is caused by externally applied loads (in.³)
- S_{nc} = section modulus for the extreme fiber of the monolithic or noncomposite section where tensile stress is caused by externally applied loads (in.³)

Appropriate values for M_{dnc} and S_{nc} shall be used for any intermediate composite sections. Where the beams are designed for the monolithic or noncomposite section to resist all loads, S_{nc} shall be substituted for S_c in the above equation for the calculation of M_{cr} .

The following factors shall be used to account for variability in the flexural cracking strength of concrete, variability of prestress, and the ratio of nominal yield stress of reinforcement to ultimate:

- γ_1 = flexural cracking variability factor
 - = 1.2 for precast segmental structures
 - = 1.6 for all other concrete structures
- γ_2 = prestress variability factor
 - = 1.1 for bonded tendons
 - = 1.0 for unbonded tendons
- γ_3 = ratio of specified minimum yield strength to ultimate tensile strength of the reinforcement
 - = 0.67 for A615, Grade 60 reinforcement
 - = 0.75 for A706, Grade 60 reinforcement
 - = 1.00 for prestressed concrete structures

The provisions of Article 5.10.8 shall apply.

Illinois demonstrated that significant inelastic displacements can be achieved, and none of the beams tested failed without large warning deflections (Freyermuth and Alami, 1997). If these experiments were conducted in load control, a number of specimens would have failed without warning because the ultimate strength (including the effects of strain hardening) was less than the cracking strength. Based on this observation, the ultimate strength should be used instead of the nominal strength as a true measure of brittle response. The ratio of steel stress at yield to ultimate (γ_3) sufficiently approximates the nominal to ultimate strength for lightly reinforced concrete members.

The sources of variability in computing the cracking moment and resistance are appropriately factored (Holombo and Tadros, 2009). The factor applied to the modulus of rupture (γ_1) is greater than the factor applied to the amount of prestress (γ_2) to account for greater variability.

For precast segmental construction, cracking generally starts at the segment joints. Research at the University of California, San Diego, has shown that flexure cracks occur adjacent to the epoxy-bonded match-cast face, where the accumulation of fines reduces the tensile strength (Megally et al., 2003). Based on this observation, a reduced (γ_1) factor of 1.2 is justified.

5.7.3.4—Control of Cracking by Distribution of Reinforcement

The provisions specified herein shall apply to the reinforcement of all concrete components, except that of deck slabs designed in accordance with Article 9.7.2, in which tension in the cross-section exceeds 80 percent of the modulus of rupture, specified in Article 5.4.2.6, at applicable service limit state load combination specified in Table 3.4.1-1.

The spacing s of mild steel reinforcement in the layer closest to the tension face shall satisfy the following:

$$s \leq \frac{700\gamma_e}{\beta_s f_{ss}} - 2d_c \quad (5.7.3.4-1)$$

in which:

$$\beta_s = 1 + \frac{d_c}{0.7(h - d_c)}$$

where:

- γ_e = exposure factor
- = 1.00 for Class 1 exposure condition
- = 0.75 for Class 2 exposure condition
- d_c = thickness of concrete cover measured from extreme tension fiber to center of the flexural reinforcement located closest thereto (in.)
- f_{ss} = tensile stress in steel reinforcement at the service limit state (ksi)
- h = overall thickness or depth of the component (in.)
- d_t = distance from the extreme compression fiber to the centroid of extreme tension steel element (in.)

C5.7.3.4

All reinforced concrete members are subject to cracking under any load condition, including thermal effects and restraint of deformations, which produces tension in the gross section in excess of the cracking strength of the concrete. Locations particularly vulnerable to cracking include those where there is an abrupt change in section and intermediate post-tensioning anchorage zones.

Provisions specified, herein, are used for the distribution of tension reinforcement to control flexural cracking.

Crack width is inherently subject to wide scatter, even in careful laboratory work, and is influenced by shrinkage and other time-dependent effects. Steps should be taken in detailing of the reinforcement to control cracking. From the standpoint of appearance, many fine cracks are preferable to a few wide cracks. Improved crack control is obtained when the steel reinforcement is well distributed over the zone of maximum concrete tension. Several bars at moderate spacing are more effective in controlling cracking than one or two larger bars of equivalent area.

Extensive laboratory work involving deformed reinforcing bars has confirmed that the crack width at the service limit state is proportional to steel stress. However, the significant variables reflecting steel detailing were found to be the thickness of concrete cover and spacing of the reinforcement.

Eq. 5.7.3.4-1 is expected to provide a distribution of reinforcement that will control flexural cracking. The equation is based on a physical crack model (Frosch, 2001) rather than the statistically-based model used in previous editions of the specifications. It is written in a form emphasizing reinforcement details, i.e., limiting bar spacing, rather than crack width. Furthermore, the physical crack model has been shown to provide a more realistic estimate of crack widths for larger concrete covers compared to the previous equation (Destefano, 2003).

Eq. 5.7.3.4-1 with Class 1 exposure condition is based on an assumed crack width of 0.017 in. Previous research indicates that there appears to be little or no correlation between crack width and corrosion, however, the different classes of exposure conditions have been so defined in order to provide flexibility in the application of these provisions to meet the needs of the Authority having jurisdiction. Class 1 exposure condition could be thought of as an upper bound in regards to crack width for appearance and corrosion. Areas that the Authority having jurisdiction may consider for Class 2 exposure condition would include decks and substructures exposed to water. The crack width is directly proportional to the γ_e exposure factor, therefore, if the individual Authority with jurisdiction desires an alternate crack width, the γ_e factor can be adjusted directly. For example a γ_e factor of 0.5 will result in an approximate crack width of 0.0085 in.

Class 1 exposure condition applies when cracks can be tolerated due to reduced concerns of appearance and/or corrosion. Class 2 exposure condition applies to transverse design of segmental concrete box girders for any loads applied prior to attaining full nominal concrete strength and when there is increased concern of appearance and/or corrosion.

In the computation of d_c , the actual concrete cover thickness is to be used.

When computing the actual stress in the steel reinforcement, axial tension effects shall be considered, while axial compression effects may be considered.

The minimum and maximum spacing of reinforcement shall also comply with the provisions of Articles 5.10.3.1 and 5.10.3.2, respectively.

The effects of bonded prestressing steel may be considered, in which case the value of f_s used in Eq. 5.7.3.4-1, for the bonded prestressing steel, shall be the stress that develops beyond the decompression state calculated on the basis of a cracked section or strain compatibility analysis.

Where flanges of reinforced concrete T-girders and box girders are in tension at the service limit state, the flexural tension reinforcement shall be distributed over the lesser of:

- The effective flange width, specified in Article 4.6.2.6, or
- A width equal to 1/10 of the average of adjacent spans between bearings.

If the effective flange width exceeds 1/10 the span, additional longitudinal reinforcement, with area not less than 0.4 percent of the excess slab area, shall be provided in the outer portions of the flange.

If d_ℓ of nonprestressed or partially prestressed concrete members exceeds 3.0 ft, longitudinal skin reinforcement shall be uniformly distributed along both side faces of the component for a distance $d_\ell/2$ nearest the flexural tension reinforcement. The area of skin reinforcement A_{sk} in in.²/ft of height on each side face shall satisfy:

$$A_{sk} \geq 0.012 (d_\ell - 30) \leq \frac{A_s + A_{ps}}{4} \quad (5.7.3.4-2)$$

where:

$$A_{ps} = \text{area of prestressing steel (in.}^2\text{)}$$

$$A_s = \text{area of tensile reinforcement (in.}^2\text{)}$$

However, the total area of longitudinal skin reinforcement (per face) need not exceed one-fourth of the required flexural tensile reinforcement $A_s + A_{ps}$.

The maximum spacing of the skin reinforcement shall not exceed either $d_\ell/6$ or 12.0 in.

Such reinforcement may be included in strength computations if a strain compatibility analysis is made to determine stresses in the individual bars or wires.

Where members are exposed to aggressive exposure or corrosive environments, additional protection beyond that provided by satisfying Eq. 5.7.3.4-1 may be provided by decreasing the permeability of the concrete and/or waterproofing the exposed surface.

Cracks in segmental concrete box girders may result from stresses due to handling and storing segments for precast construction and to stripping forms and supports from cast-in-place construction before attainment of the nominal f'_c .

The β_s factor, which is a geometric relationship between the crack width at the tension face versus the crack width at the reinforcement level, has been incorporated into the basic crack control equation in order to provide uniformity of application for flexural member depths ranging from thin slabs in box culverts to deep pier caps and thick footings. The theoretical definition of β_s may be used in lieu of the approximate expression provided.

Distribution of the negative reinforcement for control of cracking in T-girders should be made in the context of the following considerations:

- Wide spacing of the reinforcement across the full effective width of flange may cause some wide cracks to form in the slab near the web.
- Close spacing near the web leaves the outer regions of the flange unprotected.

The 1/10 of the span limitation is to guard against an excessive spacing of bars, with additional reinforcement required to protect the outer portions of the flange.

The requirements for skin reinforcement are based upon ACI 318-95. For relatively deep flexural members, some reinforcement should be placed near the vertical faces in the tension zone to control cracking in the web. Without such auxiliary steel, the width of the cracks in the web may greatly exceed the crack widths at the level of the flexural tension reinforcement.

5.7.3.5—Moment Redistribution

In lieu of more refined analysis, where bonded reinforcement that satisfies the provisions of Article 5.11 is provided at the internal supports of continuous reinforced concrete beams, negative moments determined by elastic theory at strength limit states may be increased or decreased by not more than $1000\varepsilon_r$ percent, with a maximum of 20 percent. Redistribution of negative moments shall be made only when ε_r is equal to or greater than 0.0075 at the section at which moment is reduced.

Positive moments shall be adjusted to account for the changes in negative moments to maintain equilibrium of loads and force effects.

5.7.3.6—Deformations*5.7.3.6.1—General*

The provisions of Article 2.5.2.6 shall be considered.

Deck joints and bearings shall accommodate the dimensional changes caused by loads, creep, shrinkage, thermal changes, settlement, and prestressing.

5.7.3.6.2—Deflection and Camber

Deflection and camber calculations shall consider dead load, live load, prestressing, erection loads, concrete creep and shrinkage, and steel relaxation.

For determining deflection and camber, the provisions of Articles 4.5.2.1, 4.5.2.2, and 5.9.5.5 shall apply.

In the absence of a more comprehensive analysis, instantaneous deflections may be computed using the modulus of elasticity for concrete as specified in Article 5.4.2.4 and taking the moment of inertia as either the gross moment of inertia, I_g , or an effective moment of inertia, I_e , given by Eq. 5.7.3.6.2-1:

$$I_e = \left(\frac{M_{cr}}{M_a} \right)^3 I_g + \left[1 - \left(\frac{M_{cr}}{M_a} \right)^3 \right] I_{cr} \leq I_g \quad (5.7.3.6.2-1)$$

in which:

$$M_{cr} = f_r \frac{I_g}{y_t} \quad (5.7.3.6.2-2)$$

where:

M_{cr} = cracking moment (kip-in.)
 f_r = modulus of rupture of concrete as specified in Article 5.4.2.6 (ksi)

C5.7.3.5

In editions and interims to the LRFD Specifications prior to 2005, Article 5.7.3.5 specified the permissible redistribution percentage in terms of the c/d_e ratio. The current specification specifies the permissible redistribution percentage in terms of net tensile strain ε_r . The background and basis for these provisions are given in Mast (1992).

C5.7.3.6.1

For more precise determinations of long-term deflections, the creep and shrinkage coefficients cited in Article 5.4.2.3 should be utilized. These coefficients include the effects of aggregate characteristics, humidity at the structure site, relative thickness of member, maturity at time of loading, and length of time under loads.

C5.7.3.6.2

For structures such as segmentally constructed bridges, camber calculations should be based on the modulus of elasticity and the maturity of the concrete when each increment of load is added or removed, as specified in Articles 5.4.2.3 and 5.14.2.3.6.

- y_t = distance from the neutral axis to the extreme tension fiber (in.)
- M_a = maximum moment in a component at the stage for which deformation is computed (kip-in.)

For prismatic members, effective moment of inertia may be taken as the value obtained from Eq. 5.7.3.6.2-1 at midspan for simple or continuous spans, and at support for cantilevers. For continuous nonprismatic members, the effective moment of inertia may be taken as the average of the values obtained from Eq. 5.7.3.6.2-1 for the critical positive and negative moment sections.

Unless a more exact determination is made, the long-time deflection may be taken as the instantaneous deflection multiplied by the following factor:

- If the instantaneous deflection is based on I_g : 4.0
- If the instantaneous deflection is based on I_e : $3.0 - 1.2(A'_s/A_s) \geq 1.6$

where:

- A'_s = area of compression reinforcement (in.²)
- A_s = area of nonprestressed tension reinforcement (in.²)

The contract documents shall require that deflections of segmentally constructed bridges shall be calculated prior to casting of segments based on the anticipated casting and erection schedules and that they shall be used as a guide against which actual deflection measurements are checked.

5.7.3.6.3—Axial Deformation

Instantaneous shortening or expansion due to loads shall be determined using the modulus of elasticity of the materials at the time of loading.

Instantaneous shortening or expansion due to temperature shall be determined in accordance with Articles 3.12.2, 3.12.3, and 5.4.2.2.

Long-term shortening due to shrinkage and creep shall be determined as specified in Article 5.4.2.3.

5.7.4—Compression Members

5.7.4.1—General

Unless otherwise permitted, compression members shall be analyzed with consideration of the effects of:

- Eccentricity,
- Axial loads,
- Variable moments of inertia,
- Degree of end fixity,

In prestressed concrete, the long-term deflection is usually based on mix-specific data, possibly in combination with the calculation procedures in Article 5.4.2.3. Other methods of calculating deflections which consider the different types of loads and the sections to which they are applied, such as that found in (PCI, 1992), may also be used.

C5.7.4.1

Compression members are usually prestressed only where they are subjected to a high level of flexure or when they are subjected to driving stresses, as is the case with prestressed concrete piles.

- Deflections,
- Duration of loads, and
- Prestressing.

In lieu of a refined procedure, nonprestressed columns with the slenderness ratio, $K\ell_u/r < 100$, may be designed by the approximate procedure specified in Article 5.7.4.3.

where:

K = effective length factor specified in Article 4.6.2.5

ℓ_u = unbraced length (in.)

r = radius of gyration (in.)

The requirements of this Article shall be supplemented and modified for structures in Seismic Zones 2, 3, and 4, as specified in Article 5.10.11.

Provisions shall be made to transfer all force effects from compression components, adjusted for second-order moment magnification, to adjacent components.

Where the connection to an adjacent component is by a concrete hinge, longitudinal reinforcement shall be centralized within the hinge to minimize flexural resistance and shall be developed on both sides of the hinge.

5.7.4.2—Limits for Reinforcement

C5.7.4.2

Additional limits on reinforcement for compression members in Seismic Zones 2, 3, and 4 shall be considered as specified in Articles 5.10.11.3 and 5.10.11.4.1a.

The maximum area of prestressed and nonprestressed longitudinal reinforcement for noncomposite compression components shall be such that:

$$\frac{A_s}{A_g} + \frac{A_{ps} f_{pu}}{A_g f_y} \leq 0.08 \quad (5.7.4.2-1)$$

and:

$$\frac{A_{ps} f_{pe}}{A_g f'_c} \leq 0.30 \quad (5.7.4.2-2)$$

The minimum area of prestressed and nonprestressed longitudinal reinforcement for noncomposite compression components shall be such that:

$$\frac{A_s f_y}{A_g f'_c} + \frac{A_{ps} f_{pu}}{A_g f'_c} \geq 0.135 \quad (5.7.4.2-3)$$

where:

According to current ACI codes, the area of longitudinal reinforcement for nonprestressed noncomposite compression components should be not less than $0.01 A_g$. Because the dimensioning of columns is primarily controlled by bending, this limitation does not account for the influence of the concrete compressive strength. To account for the compressive strength of concrete, the minimum reinforcement in flexural members is shown to be proportional to f'_c/f_y in Article 5.7.3.3.2. This approach is also reflected in the

A_s	=	area of nonprestressed tension steel (in. ²)
A_g	=	gross area of section (in. ²)
A_{ps}	=	area of prestressing steel (in. ²)
f_{pu}	=	specified tensile strength of prestressing steel (ksi)
f_y	=	specified yield strength of reinforcing bars (ksi)
f'_c	=	specified compressive strength of concrete (ksi)
f_{pe}	=	effective prestress (ksi)

The minimum number of longitudinal reinforcing bars in the body of a column shall be six in a circular arrangement and four in a rectangular arrangement. The minimum size of bar shall be No. 5.

For bridges in Seismic Zone 1, a reduced effective area may be used when the cross-section is larger than that required to resist the applied loading. The minimum percentage of total (prestressed and nonprestressed) longitudinal reinforcement of the reduced effective area is to be the greater of one percent or the value obtained from Eq. 5.7.4.2-3. Both the reduced effective area and the gross area must be capable of resisting all applicable load combinations from Table 3.4.1-1.

5.7.4.3—Approximate Evaluation of Slenderness Effects

For members not braced against sidesway, the effects of slenderness may be neglected where the slenderness ratio, $K\ell_u/r$, is less than 22.

For members braced against sidesway, the effects of slenderness may be neglected where $K\ell_u/r$ is less than $34-12(M_1/M_2)$, in which M_1 and M_2 are the smaller and larger end moments, respectively, and the term (M_1/M_2) is positive for single curvature flexure.

The following approximate procedure may be used for the design of nonprestressed compression members with $K\ell_u/r$ less than 100:

- The design is based on a factored axial load, P_u , determined by elastic analysis and a magnified factored moment, M_c , as specified in Article 4.5.3.2.2b.
- The unsupported length, ℓ_u , of a compression member is taken as the clear distance between components capable of providing lateral support for the compression components. Where haunches are present, the unsupported length is taken to the extremity of any haunches in the plane considered.
- The radius of gyration, r , is computed for the gross concrete section.

first term of Eq. 5.7.4.2-3. For fully prestressed members, current codes specify a minimum average prestress of 0.225 ksi. Here also the influence of compressive strength is not accounted for. A compressive strength of 5.0 ksi has been used as a basis for these provisions, and a weighted averaging procedure was used to arrive at the equation.

Where columns are pinned to their foundations, a small number of central bars have sometimes been used as a connection between footing and column.

For low risk seismic zones, the one percent reduced effective area rule, which has been used successfully since 1957 in the Standard Specifications, is implemented, but modified to account for the dependency of the minimum reinforcement on the ratio of f'_c/f_y .

For columns subjected to high, permanent axial compressive stresses where significant concrete creep is likely, using an amount of longitudinal reinforcement less than that given by Eq. 5.7.4.2-3 is not recommended because of the potential for significant transfer of load from the concrete to the reinforcement as discussed in the report of ACI Committee 105.

C5.7.4.3

These procedures were developed for reinforced concrete columns but are currently used for prestressed concrete columns as well.

For members in structures, which undergo appreciable lateral deflections resulting from combinations of vertical load or combinations of vertical and lateral loads, force effects should be determined using a second-order analysis.

For a rectangular compression member, r may be taken as 0.30 times the overall dimension in the direction in which stability is being considered. For a circular compression member, r may be taken as 0.25 times the diameter.

- For members braced against sidesway, the effective length factor, K , is taken as 1.0, unless it is shown by analysis that a lower value may be used.
- For members not braced against sidesway, K is determined with due consideration for the effects of cracking and reinforcement on relative stiffness and is taken as not less than 1.0.

In lieu of a more precise calculation, EI for use in determining P_e , as specified in Eq. 4.5.3.2.2b-5, shall be taken as the greater of:

$$EI = \frac{\frac{E_c I_g}{5} + E_s I_s}{1 + \beta_d} \quad (5.7.4.3-1)$$

$$EI = \frac{\frac{E_c I_g}{2.5}}{1 + \beta_d} \quad (5.7.4.3-2)$$

where:

- E_c = modulus of elasticity of concrete (ksi)
- I_g = moment of inertia of the gross concrete section about the centroidal axis (in.⁴)
- E_s = modulus of elasticity of longitudinal steel (ksi)
- I_s = moment of inertia of longitudinal steel about the centroidal axis (in.⁴)
- β_d = ratio of maximum factored permanent load moments to maximum factored total load moment; always positive

For eccentrically prestressed members, consideration shall be given to the effect of lateral deflection due to prestressing in determining the magnified moment.

5.7.4.4—Factored Axial Resistance

The factored axial resistance of concrete compressive components, symmetrical about both principal axes, shall be taken as:

$$P_r = \phi P_n \quad (5.7.4.4-1)$$

in which:

- For members with spiral reinforcement:

$$P_n = 0.85 \left[\begin{array}{l} 0.85 f'_c (A_g - A_{st} - A_{ps}) \\ + f_y A_{st} - A_{ps} (f_{pe} - E_p \epsilon_{cu}) \end{array} \right] \quad (5.7.4.4-2)$$

- For members with tie reinforcement:

$$P_n = 0.80 \left[\begin{array}{l} 0.85 f'_c (A_g - A_{st} - A_{ps}) \\ + f_y A_{st} - A_{ps} (f_{pe} - E_p \epsilon_{cu}) \end{array} \right] \quad (5.7.4.4-3)$$

C5.7.4.4

The values of 0.85 and 0.80 in Eqs. 5.7.4.4-2 and 5.7.4.4-3 place upper limits on the usable resistance of compression members to allow for unintended eccentricity.

In the absence of concurrent bending due to external loads or eccentric application of prestress, the ultimate strain on a compression member is constant across the entire cross-section. Prestressing causes compressive stresses in the concrete, which reduces the resistance of compression members to externally applied axial loads. The term, $E_p \epsilon_{cu}$, accounts for the fact that a column or pile also shortens under externally applied loads, which serves to reduce the level of compression due to prestress. Assuming a concrete compressive strain at ultimate, $\epsilon_{cu} = 0.003$, and a prestressing steel modulus, $E_p = 28,500$ ksi, gives a relatively constant value of 85.0 ksi for the amount of this reduction. Therefore, it is acceptable to reduce the effective prestressing by this amount. Conservatively, this reduction can be ignored.

where:

- P_r = factored axial resistance, with or without flexure (kip)
- P_n = nominal axial resistance, with or without flexure (kip)
- f'_c = specified strength of concrete at 28 days, unless another age is specified (ksi)
- A_g = gross area of section (in.²)
- A_{st} = total area of longitudinal reinforcement (in.²)
- f_y = specified yield strength of reinforcement (ksi)
- ϕ = resistance factor specified in Article 5.5.4.2
- A_{ps} = area of prestressing steel (in.²)
- E_p = modulus of elasticity of prestressing tendons (ksi)
- f_{pe} = effective stress in prestressing steel after losses (ksi)
- ϵ_{cu} = failure strain of concrete in compression (in./in.)

5.7.4.5—Biaxial Flexure

In lieu of an analysis based on equilibrium and strain compatibility for biaxial flexure, noncircular members subjected to biaxial flexure and compression may be proportioned using the following approximate expressions:

- If the factored axial load is not less than $0.10 \phi f'_c A_g$:

$$\frac{1}{P_{rxy}} = \frac{1}{P_{rx}} + \frac{1}{P_{ry}} - \frac{1}{\phi P_o} \quad (5.7.4.5-1)$$

in which:

$$P_o = 0.85 f'_c (A_g - A_{st} - A_{ps}) + f_y A_{st} - A_{ps} (f_{pe} - E_p \epsilon_{cu}) \quad (5.7.4.5-2)$$

- If the factored axial load is less than $0.10 \phi f'_c A_g$:

$$\frac{M_{ux}}{M_{rx}} + \frac{M_{uy}}{M_{ry}} \leq 1.0 \quad (5.7.4.5-3)$$

where:

- ϕ = resistance factor for members in axial compression
- P_{rxy} = factored axial resistance in biaxial flexure (kip)
- P_{rx} = factored axial resistance determined on the basis that only eccentricity e_y is present (kip)
- P_{ry} = factored axial resistance determined on the basis that only eccentricity e_x is present (kip)
- P_u = factored applied axial force (kip)

C5.7.4.5

Eqs. 5.7.3.2.1-1 and 5.7.4.4-1 relate factored resistances, given in Eqs. 5.7.4.5-1 and 5.7.4.5-2 by the subscript r , e.g., M_{rx} , to the nominal resistances and the resistance factors. Thus, although previous editions of the Standard Specifications included the resistance factor explicitly in equations corresponding to Eqs. 5.7.4.5-1 and 5.7.4.5-2, these Specifications implicitly include the resistance factor by using factored resistances in the denominators.

The procedure for calculating corresponding values of M_{rx} and P_{rx} or M_{ry} and P_{ry} can be found in most texts on reinforced concrete design.

- M_{ux} = factored applied moment about the x -axis (kip-in.)
 M_{uy} = factored applied moment about the y -axis (kip-in.)
 e_x = eccentricity of the applied factored axial force in the x direction, i.e., $= M_{uy}/P_u$ (in.)
 e_y = eccentricity of the applied factored axial force in the y direction, i.e., $= M_{ux}/P_u$ (in.)
 P_o = nominal axial resistance of a section at 0.0 eccentricity

The factored axial resistance P_{rx} and P_{ry} shall not be taken to be greater than the product of the resistance factor, ϕ , and the maximum nominal compressive resistance given by either Eqs. 5.7.4.4-2 or 5.7.4.4-3, as appropriate.

5.7.4.6—Spirals and Ties

The area of steel for spirals and ties in bridges in Seismic Zones 2, 3, or 4 shall comply with the requirements specified in Article 5.10.11.

Where the area of spiral and tie reinforcement is not controlled by:

- Seismic requirements,
- Shear or torsion as specified in Article 5.8, or
- Minimum requirements as specified in Article 5.10.6,

the ratio of spiral reinforcement to total volume of concrete core, measured out-to-out of spirals, shall satisfy:

$$\rho_s \geq 0.45 \left(\frac{A_g}{A_c} - 1 \right) \frac{f'_c}{f_{yh}} \quad (5.7.4.6-1)$$

where:

- A_g = gross area of concrete section (in.²)
 A_c = area of core measured to the outside diameter of the spiral (in.²)
 f'_c = specified strength of concrete at 28 days, unless another age is specified (ksi)
 f_{yh} = specified yield strength of spiral reinforcement (ksi)

Other details of spiral and tie reinforcement shall conform to the provisions of Articles 5.10.6 and 5.10.11.

5.7.4.7—Hollow Rectangular Compression Members

5.7.4.7.1—Wall Slenderness Ratio

C5.7.4.7.1

The wall slenderness ratio of a hollow rectangular cross-section shall be taken as:

The definition of the parameter X_u is illustrated in Figure C5.7.4.7.1-1, taken from Taylor et al. (1990).

$$\lambda_w = \frac{X_u}{t} \quad (5.7.4.7.1-1)$$

where:

X_u = the clear length of the constant thickness portion of a wall between other walls or fillets between walls (in.)

t = thickness of wall (in.)

λ_w = wall slenderness ratio for hollow columns

Wall slenderness greater than 35 may be used only when the behavior and resistance of the wall is documented by analytic and experimental evidence acceptable to the Owner.

5.7.4.7.2—Limitations on the Use of the Rectangular Stress Block Method

5.7.4.7.2a—General

Except as specified in Article 5.7.4.7.2c, the equivalent rectangular stress block method shall not be employed in the design of hollow rectangular compression members with a wall slenderness ratio ≥ 15 .

Where the wall slenderness ratio is less than 15, the rectangular stress block method may be used based on a compressive strain of 0.003.

5.7.4.7.2b—Refined Method for Adjusting Maximum Usable Strain Limit

Where the wall slenderness ratio is 15 or greater, the maximum usable strain at the extreme concrete compression fiber is equal to the lesser of the computed local buckling strain of the widest flange of the cross-section, or 0.003.

The local buckling strain of the widest flange of the cross-section may be computed assuming simply supported boundary conditions on all four edges of the flange. Nonlinear material behavior shall be considered by incorporating the tangent material moduli of the concrete and reinforcing steel in computations of the local buckling strain.

Discontinuous, nonpost-tensioned reinforcement in segmentally constructed hollow rectangular compression members shall be neglected in computations of member strength.

Flexural resistance shall be calculated using the principles of Article 5.7.3 applied with anticipated stress-strain curves for the types of material to be used.

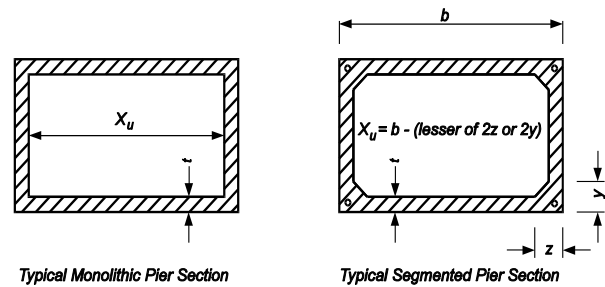

Figure C5.7.4.7.1-1—Illustration of X_u

The test program, reported in Taylor et al. (1990), was limited to the case of loading under simultaneous axial and uniaxial bending about the weak axis of the section. The results of the study have not been confirmed for the case of biaxial bending. Until such a study is completed, the Designer should investigate the effects of biaxial loading on hollow sections.

5.7.4.7.2c—Approximate Method for Adjusting Factored Resistance

The provisions of this Article and the rectangular stress block method may be used in lieu of the provisions of Articles 5.7.4.7.2a and 5.7.4.7.2b where the wall slenderness is ≤ 35 .

The factored resistance of a hollow column, determined using a maximum usable strain of 0.003, and the resistance factors specified in Article 5.5.4.2 shall be further reduced by a factor ϕ_w , taken as:

- If $\lambda_w \leq 15$, then $\phi_w = 1.0$ (5.7.4.7.2c-1)

- If $15 < \lambda_w \leq 25$, then $\phi_w = 1 - 0.025(\lambda_w - 15)$ (5.7.4.7.2c-2)

- If $25 < \lambda_w \leq 35$, then $\phi_w = 0.75$ (5.7.4.7.2c-3)

5.7.5—Bearing

C5.7.5

In the absence of confinement reinforcement in the concrete supporting the bearing device, the factored bearing resistance shall be taken as:

$$P_r = \phi P_n \quad (5.7.5-1)$$

in which:

$$P_n = 0.85 f'_c A_1 m \quad (5.7.5-2)$$

where:

- P_n = nominal bearing resistance (kip)
- A_1 = area under bearing device (in.²)
- m = modification factor
- A_2 = a notional area defined herein (in.²)

The modification factor may be determined as follows:

- Where the supporting surface is wider on all sides than the loaded area:

$$m = \sqrt{\frac{A_2}{A_1}} \leq 2.0 \quad (5.7.5-3)$$

- Where the loaded area is subjected to nonuniformly distributed bearing stresses:

$$m = 0.75 \sqrt{\frac{A_2}{A_1}} \leq 1.50 \quad (5.7.5-4)$$

Where the supporting surface is sloped or stepped, A_2 may be taken as the area of the lower base of the largest frustum of a right pyramid, cone, or tapered wedge contained wholly within the support and having for its upper base the loaded area, as well as side slopes of 1.0 vertical to 2.0 horizontal.

Where the factored applied load exceeds the factored resistance, as specified herein, provisions shall be made to resist the bursting and spalling forces in accordance with Article 5.10.9.

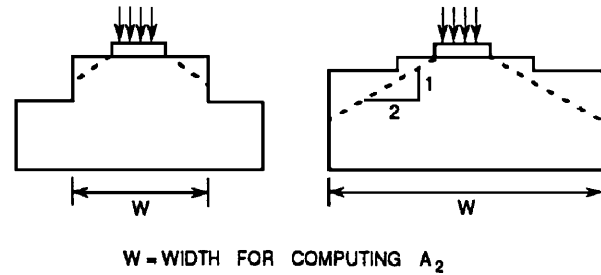

Figure C5.7.5-1—Determination of A_2 for a Stepped Support

5.7.6—Tension Members

5.7.6.1—Factored Tension Resistance

Members in which the factored loads induce tensile stresses throughout the cross-section shall be regarded as tension members, and the axial force shall be assumed to be resisted only by the steel elements. The provisions of Article 5.11.5.4 shall apply.

The factored resistance to uniform tension shall be taken as:

$$P_r = \phi P_n \quad (5.7.6.1-1)$$

where:

P_n = nominal tension resistance specified in Article 5.6.3.4

ϕ = resistance factor specified in Article 5.5.4.2

5.7.6.2—Resistance to Combinations of Tension and Flexure

Members subjected to eccentric tension loading, which induces both tensile and compressive stresses in the cross-section, shall be proportioned in accordance with the provisions of Article 5.7.2.

5.8—SHEAR AND TORSION

5.8.1—Design Procedures

5.8.1.1—Flexural Regions

Where it is reasonable to assume that plane sections remain plane after loading, regions of components shall be designed for shear and torsion using either the sectional model as specified in Article 5.8.3 or the strut-and-tie model as specified in Article 5.6.3. The requirements of Article 5.8.2 shall apply.

In lieu of the provisions of Article 5.8.3, segmental post-tensioned concrete box girder bridges may be designed for shear and torsion using the provisions of Article 5.8.6.

C5.8.1.1

The sectional model is appropriate for the design of typical bridge girders, slabs, and other regions of components where the assumptions of traditional engineering beam theory are valid. This theory assumes that the response at a particular section depends only on the calculated values of the sectional force effects, i.e., moment, shear, axial load, and torsion, and does not consider the specific details of how the force effects were introduced into the member. Although the strut-and-tie model can be applied to flexural regions, it is

Components in which the distance from the point of zero shear to the face of the support is less than $2d$, or components in which a load causing more than 1/2 (1/3 in case of segmental box girders) of the shear at a support is closer than $2d$ from the face of the support, may be considered to be deep components for which the provisions of Article 5.6.3 and the detailing requirements of Article 5.13.2.3 apply.

5.8.1.2—Regions Near Discontinuities

Where the plane sections assumption of flexural theory is not valid, regions of members shall be designed for shear and torsion using the strut-and-tie model as specified in Article 5.6.3. The provisions of Article 5.13.2 shall apply.

5.8.1.3—Interface Regions

Interfaces between elements shall be designed for shear transfer in accordance with the provisions of Article 5.8.4.

5.8.1.4—Slabs and Footings

Slab-type regions shall be designed for shear in accordance with the provisions of Article 5.13.3.6 or Article 5.6.3.

5.8.1.5—Webs of Curved Post-Tensioned Box Girder Bridges

Curved post-tensioned box girders having an overall clear height, h_c , in excess of 4 ft shall be designed for the following combined effects before and after losses:

- The combined effects of global shear resulting from vertical shear and torsion,
- Transverse web regional bending resulting from lateral prestress force, and
- Transverse web bending from vertical loads and transverse post-tensioning.

5.8.2—General Requirements

5.8.2.1—General

The factored torsional resistance, T_r , shall be taken as:

$$T_r = \phi T_n \quad (5.8.2.1-1)$$

more appropriate and generally yields less conservative designs for regions near discontinuities where the actual flow of forces should be considered in more detail.

C5.8.1.2

The response of regions adjacent to abrupt changes in cross-section, openings, dapped ends, deep beams, and corbels is influenced significantly by the details of how the loads are introduced into the region and how the region is supported.

C5.8.1.5

Transverse web bending is a function of the vertical loads, restoring effect of the longitudinal prestressing, the Resal effect, and any transverse prestressing. Considering global web shear and regional web transverse bending alone will tend to underestimate the amount of vertical reinforcing steel required in the webs. More rigorous approaches that consider the interaction of these combined forces are presented in Menn (1990) and Nutt (2008).

C5.8.2.1

where:

T_n = nominal torsional resistance specified in Article 5.8.3.6 (kip-in.)

ϕ = resistance factor specified in Article 5.5.4.2

The factored shear resistance, V_r , shall be taken as:

$$V_r = \phi V_n \tag{5.8.2.1-2}$$

V_n = nominal shear resistance specified in Article 5.8.3.3 (kip)

ϕ = resistance factor as specified in Article 5.5.4.2

For normal weight concrete, torsional effects shall be investigated where:

$$T_u > 0.25\phi T_{cr} \tag{5.8.2.1-3}$$

in which:

$$T_{cr} = 0.125\sqrt{f'_c} \frac{A_{cp}^2}{p_c} \sqrt{1 + \frac{f_{pc}}{0.125\sqrt{f'_c}}} \tag{5.8.2.1-4}$$

where:

T_u = factored torsional moment (kip-in.)

T_{cr} = torsional cracking moment (kip-in.)

A_{cp} = total area enclosed by outside perimeter of concrete cross-section (in.²)

p_c = the length of the outside perimeter of the concrete section (in.)

f_{pc} = compressive stress in concrete after prestress losses have occurred either at the centroid of the cross-section resisting transient loads or at the junction of the web and flange where the centroid lies in the flange (ksi)

ϕ = resistance factor specified in Article 5.5.4.2

For cellular structures:

$$\frac{A_{cp}^2}{p_c} \leq 2A_o b_v \tag{5.8.2.1-5}$$

where:

A_o = area enclosed by the shear flow path, including any area of holes therein (in.²)

The equivalent factored shear force, V_u , shall be taken equal to:

For solid sections:

If the factored torsional moment is less than one-quarter of the factored pure torsional cracking moment, it will cause only a very small reduction in shear capacity or flexural capacity and, hence, can be neglected.

Sections that are designed for live loads using approximate methods of analysis in Article 4.6.2.2 need not be investigated for torsion.

The limit to Eq. 5.8.2.1-4 was added to avoid over-estimating T_{cr} in the case of cellular structures. Eq. 5.8.2.1-4 was derived from a solid section assuming an equivalent thin wall tube. When the actual b_v and A_{cp}^2 is considered, torsional resistance can be much less. The resulting expression matches that in the current edition of AASHTO's *Guide Specifications for Design and Construction of Segmental Bridges*.

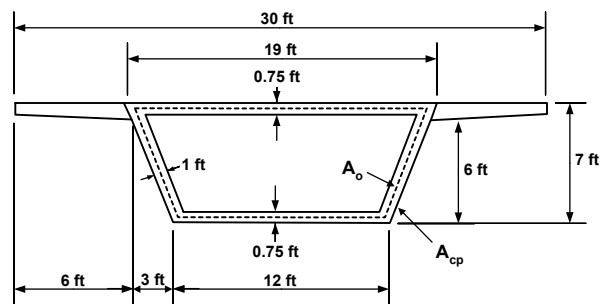

Figure C5.8.2.1-1—Sketch Showing Data Used in Sample Calculation for A_o Shown Below

$$A_o = \frac{1}{2}(11 \text{ ft} + 18 \text{ ft})(6.25 \text{ ft}) = 90.6 \text{ ft}^2$$

$$\sqrt{V_u^2 + \left(\frac{0.9p_h T_u}{2A_o}\right)^2} \quad (5.8.2.1-6)$$

For box sections:

$$V_u + \frac{T_u d_s}{2A_o} \quad (5.8.2.1-7)$$

where:

- p_h = perimeter of the centerline of the closed transverse torsion reinforcement (in.)
 T_u = factored torsional moment (kip-in.)

Alternatively, the term A_o can usually be taken as 85 percent of the area enclosed by the centerline of the exterior closed transverse torsion reinforcement, including area of any holes. The justification for this generally conservative substitution is given in Collins and Mitchell (1991).

A stress limit for principal tension at the neutral axis in the web was added in 2004. This check requires shear demand, and not the resistance, to be modified for torsion. Eqs. 5.8.2.1-6 and 5.8.2.1-7 were added to clarify how demand is modified for torsion. Note that the V_u in Eqs. 5.8.3.4.2-1, 5.8.3.4.2-2, and 5.8.3.4.2-3 for ϵ_s , and in Eq. 5.8.2.9-1 for v_u , are not modified for torsion.

For solid cross-section shapes, such as a rectangle or an “I,” there is the possibility of considerable redistribution of shear stresses. To make some allowance for this favorable redistribution it is safe to use a root-mean-square approach in calculating the nominal shear stress for these cross-sections, as indicated in Eq. 5.8.2.1-6. The $0.9p_h$ comes from 90 percent of the perimeter of the spalled concrete section. This is similar to multiplying 0.9 times the lever arm in flexural calculations.

For a box girder, the shear flow due to torsion is added to the shear flow due to flexure in one exterior web, and subtracted from the opposite exterior web. In the controlling web, the second term in Eq. 5.8.2.1-7 comes from integrating the distance from the centroid of the section, to the center of the shear flow path around the circumference of the section. The stress is converted to a force by multiplying by the web height measured between the shear flow paths in the top and bottom slabs, which has a value approximately equal that of d_s . If the exterior web is sloped, this distance should be divided by the sine of the web angle from horizontal.

5.8.2.2—Modifications for Lightweight Concrete

Where lightweight aggregate concretes are used, the following modifications shall apply in determining resistance to torsion and shear:

- Where the average splitting tensile strength of lightweight concrete, f_{ct} , is specified, the term $\sqrt{f'_c}$ in the expressions given in Articles 5.8.2 and 5.8.3 shall be replaced by:

$$4.7f_{ct} \leq \sqrt{f'_c}$$

- Where f_{ct} is not specified, the term $0.75\sqrt{f'_c}$ for all lightweight concrete, and $0.85\sqrt{f'_c}$ for sand-lightweight concrete shall be substituted for $\sqrt{f'_c}$ in the expressions given in Articles 5.8.2 and 5.8.3

Linear interpolation may be employed when partial sand replacement is used.

C5.8.2.2

The tensile strength and shear capacity of lightweight concrete is typically somewhat less than that of normal weight concrete having the same compressive strength.

5.8.2.3—Transfer and Development Lengths

The provisions of Article 5.11.4 shall be considered.

5.8.2.4—Regions Requiring Transverse Reinforcement

Except for slabs, footings, and culverts, transverse reinforcement shall be provided where:

- $V_u > 0.5\phi(V_c + V_p)$ (5.8.2.4-1)

or

- Where consideration of torsion is required by Eq. 5.8.2.1-3 or Eq. 5.8.6.3-1

where:

- V_u = factored shear force (kip)
- V_c = nominal shear resistance of the concrete (kip)
- V_p = component of prestressing force in direction of the shear force; $V_p = 0$ when the simplified method of 5.8.3.4.3 is used (kip)
- ϕ = resistance factor specified in Article 5.5.4.2

5.8.2.5—Minimum Transverse Reinforcement

Except for segmental post-tensioned concrete box girder bridges, where transverse reinforcement is required, as specified in Article 5.8.2.4, the area of steel shall satisfy:

$$A_v \geq 0.0316 \sqrt{f'_c} \frac{b_v s}{f_y} \quad (5.8.2.5-1)$$

where:

- A_v = area of a transverse reinforcement within distance s (in.²)
- b_v = width of web adjusted for the presence of ducts as specified in Article 5.8.2.9 (in.)
- s = spacing of transverse reinforcement (in.)
- f_y = yield strength of transverse reinforcement (ksi)

For segmental post-tensioned concrete box girder bridges, where transverse reinforcement is required, as specified in Article 5.8.6.5, the area of transverse reinforcement shall satisfy:

$$A_v \geq 0.05 \frac{b_w s}{f_y} \quad (5.8.2.5-2)$$

where:

- A_v = area of a transverse shear reinforcement per web within distance s (in.²)
- b_w = width of web (in.)

C5.8.2.3

The reduced prestress in the transfer length reduces V_p , f_{pc} , and f_{pe} . The transfer length influences the tensile force that can be resisted by the tendons at the inside edge of the bearing area, as described in Article 5.8.3.5.

C5.8.2.4

Transverse reinforcement, which usually consists of stirrups, is required in all regions where there is a significant chance of diagonal cracking.

C5.8.2.5

A minimum amount of transverse reinforcement is required to restrain the growth of diagonal cracking and to increase the ductility of the section. A larger amount of transverse reinforcement is required to control cracking as the concrete strength is increased.

Additional transverse reinforcement may be required for transverse web bending.

- s = spacing of transverse reinforcement (in.)
 f_y = yield strength of transverse reinforcement (ksi)

For segmental post-tensioned concrete box girder bridges, where transverse reinforcement is not required, as specified in Article 5.8.6.5, the minimum area of transverse shear reinforcement per web shall not be less than the equivalent of two No. 4 Grade 60 reinforcement bars per foot of length.

5.8.2.6—Types of Transverse Reinforcement

Transverse reinforcement to resist shear may consist of:

- Stirrups perpendicular to the longitudinal axis of the member;
- Welded wire reinforcement, with wires located perpendicular to the longitudinal axis of the member, provided that the transverse wires are certified to undergo a minimum elongation of four percent, measured over a gage length of at least 4.0 in. including at least one cross wire;
- Anchored prestressed tendons, detailed and constructed to minimize seating and time-dependent losses, which make an angle not less than 45 degrees with the longitudinal tension reinforcement;
- Combinations of stirrups, tendons, and bent longitudinal bars;
- Spirals or hoops;
- Inclined stirrups making an angle of not less than 45 degrees with the longitudinal tension reinforcement; or
- Bent longitudinal bars in nonprestressed members with the bent portion making an angle of 30 degrees or more with the longitudinal tension reinforcement.

Inclined stirrups and bent longitudinal reinforcement shall be spaced so that every 45-degree line, extending towards the reaction from mid-depth of the member, $h/2$, to the longitudinal tension reinforcement shall be crossed by at least one line of transverse reinforcement.

Transverse reinforcement shall be detailed such that the shear force between different elements or zones of a member are effectively transferred.

Torsional reinforcement shall consist of both transverse and longitudinal reinforcement. Longitudinal reinforcement shall consist of bars and/or tendons. Transverse reinforcement may consist of:

- Closed stirrups or closed ties, perpendicular to the longitudinal axis of the member, as specified in Article 5.11.2.6.4,

C5.8.2.6

Stirrups inclined at less than 45 degrees to the longitudinal reinforcement are difficult to anchor effectively against slip and, hence, are not permitted. Inclined stirrups and prestressed tendons should be oriented to intercept potential diagonal cracks at an angle as close to normal as practical.

To increase shear capacity, transverse reinforcement should be capable of undergoing substantial strain prior to failure. Welded wire fabric, particularly if fabricated from small wires and not stress-relieved after fabrication, may fail before the required strain is reached. Such failures may occur at or between the cross-wire intersections.

For some large bridge girders, prestressed tendons perpendicular to the member axis may be an efficient form of transverse reinforcement. Because the tendons are short, care must be taken to avoid excessive loss of prestress due to anchorage slip or seating losses. The requirements for transverse reinforcement assume it is perpendicular to the longitudinal axis of prismatic members or vertical for nonprismatic or tapered members. Requirements for bent bars were added to make the provisions consistent with those in AASHTO (2002).

- A closed cage of welded wire reinforcement with transverse wires perpendicular to the longitudinal axis of the member, or
- Spirals or hoops.

5.8.2.7—Maximum Spacing of Transverse Reinforcement

The spacing of the transverse reinforcement shall not exceed the maximum permitted spacing, s_{max} , determined as:

- If $v_u < 0.125 f'_c$, then:

$$s_{max} = 0.8d_v \leq 24.0 \text{ in.} \quad (5.8.2.7-1)$$

- If $v_u \geq 0.125 f'_c$, then:

$$s_{max} = 0.4d_v \leq 12.0 \text{ in.} \quad (5.8.2.7-2)$$

where:

v_u = the shear stress calculated in accordance with Article 5.8.2.9 (ksi)

d_v = effective shear depth as defined in Article 5.8.2.9 (in.)

For segmental post-tensioned concrete box girder bridges, spacing of closed stirrups or closed ties required to resist shear effects due to torsional moments shall not exceed one-half of the shortest dimension of the cross-section, nor 12.0 in.

5.8.2.8—Design and Detailing Requirements

Transverse reinforcement shall be anchored at both ends in accordance with the provisions of Article 5.11.2.6. For composite flexural members, extension of beam shear reinforcement into the deck slab may be considered when determining if the development and anchorage provisions of Article 5.11.2.6 are satisfied.

The design yield strength of nonprestressed transverse reinforcement shall be taken equal to the specified yield strength when the latter does not exceed 60.0 ksi. For nonprestressed transverse reinforcement with yield strength in excess of 60.0 ksi, the design yield strength shall be taken as the stress corresponding to a strain of 0.0035, but not to exceed 75.0 ksi. The design yield strength of prestressed transverse reinforcement shall be taken as the effective stress, after allowance for all prestress losses, plus 60.0 ksi, but not greater than f_{py} .

C5.8.2.7

Sections that are highly stressed in shear require more closely spaced reinforcement to provide crack control.

C5.8.2.8

To be effective, the transverse reinforcement should be anchored at each end in a manner that minimizes slip. Fatigue of welded wire reinforcement is not a concern in prestressed members as long as the specially fabricated reinforcement is detailed to have welded joints only in the flanges where shear stress is low.

Some of the provisions of Article 5.8.3 are based on the assumption that the strain in the transverse reinforcement has to attain a value of 0.002 to develop its yield strength. For prestressed tendons, it is the additional strain required to increase the stress above the effective stress caused by the prestress that is of concern. Limiting the design yield strength of nonprestressed transverse reinforcement to 75.0 ksi or a stress corresponding to a strain of 0.0035 provides control of crack widths at service limit state. For reinforcement without a well-defined yield point, the yield strength is determined at a strain of 0.0035 at strength limit state. Research by Griezic (1994), Ma (2000), and Bruce (2003) has indicated that the performance of higher strength steels as shear reinforcement has been satisfactory. Use of relatively small diameter deformed welded wire reinforcement at

When welded wire reinforcement is used as transverse reinforcement, it shall be anchored at both ends in accordance with Article 5.11.2.6.3. No welded joints other than those required for anchorage shall be permitted.

Components of inclined flexural compression and/or flexural tension in variable depth members shall be considered when calculating shear resistance.

5.8.2.9—Shear Stress on Concrete

The shear stress on the concrete shall be determined as:

$$v_u = \frac{|V_u - \phi V_p|}{\phi b_v d_v} \quad (5.8.2.9-1)$$

where:

ϕ = resistance factor for shear specified in Article 5.5.4.2

b_v = effective web width taken as the minimum web width, measured parallel to the neutral axis, between the resultants of the tensile and compressive forces due to flexure, or for circular sections, the diameter of the section, modified for the presence of ducts where applicable (in.)

d_v = effective shear depth taken as the distance, measured perpendicular to the neutral axis, between the resultants of the tensile and compressive forces due to flexure; it need not be taken to be less than the greater of $0.9 d_e$ or $0.72h$ (in.)

in which:

$$d_e = \frac{A_{ps} f_{ps} d_p + A_s f_y d_s}{A_{ps} f_{ps} + A_s f_y} \quad (5.8.2.9-2)$$

In determining the web width at a particular level, one-half the diameters of ungrouted ducts or one-quarter the diameter of grouted ducts at that level shall be subtracted from the web width.

relatively small spacing, compared to individually field tied reinforcing bars results in improved quality control and improved member performance in service.

The components in the direction of the applied shear of inclined flexural compression and inclined flexural tension can be accounted for in the same manner as the component of the longitudinal prestressing force, V_p .

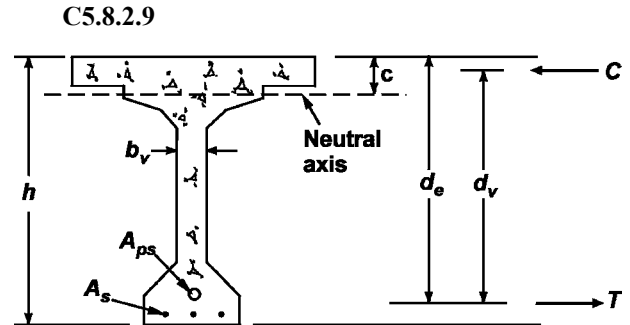

Figure C5.8.2.9-1—Illustration of the Terms b_v and d_v

For flexural members, the distance between the resultants of the tensile and compressive forces due to flexure can be determined as:

$$d_v = \frac{M_n}{A_s f_y + A_{ps} f_{ps}} \quad (C5.8.2.9-1)$$

In continuous members near the point of inflection, if Eq. C5.8.2.9-1 is used, it should be evaluated in terms of both the top and the bottom reinforcement. Note that other limitations on the value of d_v to be used are specified and that d_v is the value at the section at which shear is being investigated.

Previous editions of the Standard Specifications permitted d for prestressed members to be taken as $0.8h$. The $0.72h$ limit on d_v is $0.9 \times 0.8h$.

Post-tensioning ducts act as discontinuities and hence, can reduce the crushing strength of concrete webs. In determining which level over the effective depth of the beam has the minimum width, and hence controls b_v , levels which contain a post-tensioning duct or several ducts shall have their widths reduced. Thus, for the section shown in Figure C5.8.2.9-1, the post-tensioning duct in the position shown would not reduce b_v , because it is not at a level where the width of the section is close to the minimum value. If the location of the tendon was raised such that the tendon is located within the narrow portion of the web, the value of b_v would be reduced.

For circular members, such as reinforced concrete columns or prestressed concrete piles, d_v can be determined from Eq. C5.8.2.9-1 provided that M_n is calculated ignoring the effects of axial load and that the reinforcement areas, A_s and A_{ps} , are taken as the reinforcement in one-half of the section. Alternatively, d_v can be taken as $0.9d_e$, where:

$$d_e = \frac{D}{2} + \frac{D_r}{\pi} \quad (\text{C5.8.2.9-2})$$

where:

D = external diameter of the circular member (in.)
 D_r = diameter of the circle passing through the centers of the longitudinal reinforcement (in.)

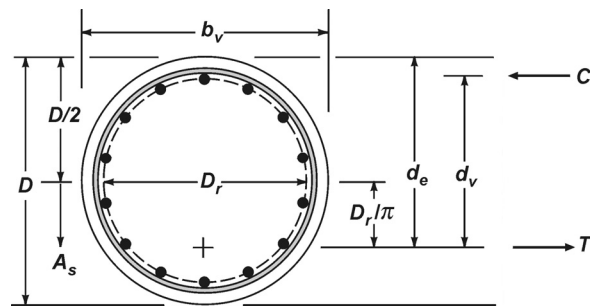

Figure C5.8.2.9-2—Illustration of Terms b_v , d_v , and d_e for Circular Sections

Circular members usually have the longitudinal reinforcement uniformly distributed around the perimeter of the section. When the member cracks, the highest shear stresses typically occur near the middepth of the section. This is also true when the section is not cracked. It is for this reason that the effective web width can be taken as the diameter of the section.

5.8.3—Sectional Design Model

5.8.3.1—General

The sectional design model may be used for shear design where permitted in accordance with the provisions of Article 5.8.1.

In lieu of the methods specified herein, the resistance of members in shear or in shear combined with torsion may be determined by satisfying the conditions of equilibrium and compatibility of strains and by using experimentally verified stress-strain relationships for reinforcement and for diagonally cracked concrete. Where consideration of simultaneous

C5.8.3.1

In the sectional design approach, the component is investigated by comparing the factored shear force and the factored shear resistance at a number of sections along its length. Usually this check is made at the tenth points of the span and at locations near the supports.

See Articles 5.10.11.3 and 5.10.11.4.1c for additional requirements for Seismic Zones 2, 3, and 4 and Articles 5.8.1.2 and 5.8.3.2 for additional requirements for member end regions.

An appropriate nonlinear finite element analysis or a detailed sectional analysis would satisfy the requirements of this Article. More information on appropriate procedures and a computer program that satisfies these requirements are given by Collins and Mitchell (1991). One possible approach to the analysis of biaxial shear and other complex loadings on concrete members is outlined

shear in a second direction is warranted, investigation shall be based either on the principles outlined above or on a three-dimensional strut-and-tie model.

5.8.3.2—Sections Near Supports

The provisions of Article 5.8.1.2 shall be considered.

Where the reaction force in the direction of the applied shear introduces compression into the end region of a member, the location of the critical section for shear shall be taken as d_v from the internal face of the support as illustrated in Figure 5.8.3.2-1.

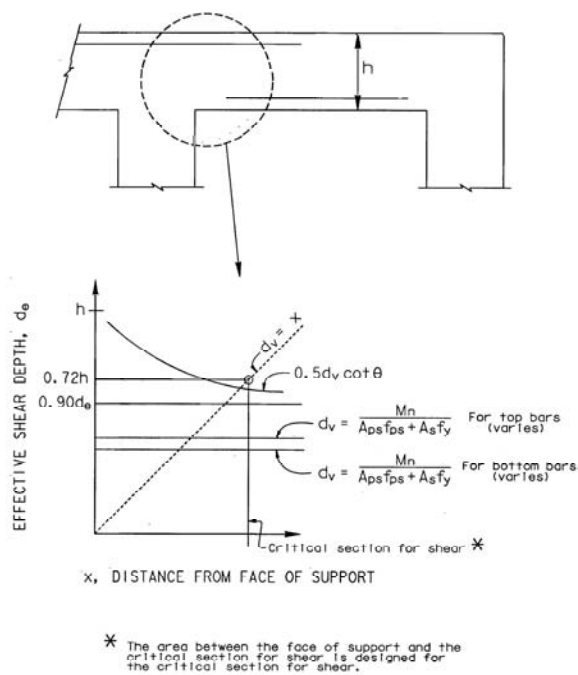

Figure 5.8.3.2-1—Critical Section for Shear

Otherwise, the design section shall be taken at the internal face of the support. Where the beam-type element extends on both sides of the reaction area, the design section on each side of the reaction shall be determined separately based upon the loads on each side of the reaction and whether their respective contribution to the total reaction introduces tension or compression into the end region.

For post-tensioned beams, anchorage zone reinforcement shall be provided as specified in Article 5.10.9. For pretensioned beams, a reinforcement cage confining the ends of strands shall be provided as specified in Article 5.10.10. For nonprestressed beams supported on bearings that introduce compression into the member, only minimal transverse reinforcement may be provided between the inside edge of the bearing plate or pad and the end of the beam.

in Rabbat and Collins (1978), and a corresponding computer-aided solution is presented in Rabbat and Collins (1976). A discussion of the effect of biaxial shear on the design of reinforced concrete beam-to-column joints can be found in Paulay and Priestley (1992).

C5.8.3.2

Loads close to the support are transferred directly to the support by compressive arching action without causing additional stresses in the stirrups.

The traditional approach to proportioning transverse reinforcement involves the determination of the required stirrup spacing at discrete sections along the member. The stirrups are then detailed such that this spacing is not exceeded over a length of the beam extending from the design section to the next design section out into the span. In such an approach, the shear demand and resistance provided is assumed to be as shown in Figure C5.8.3.2-1.

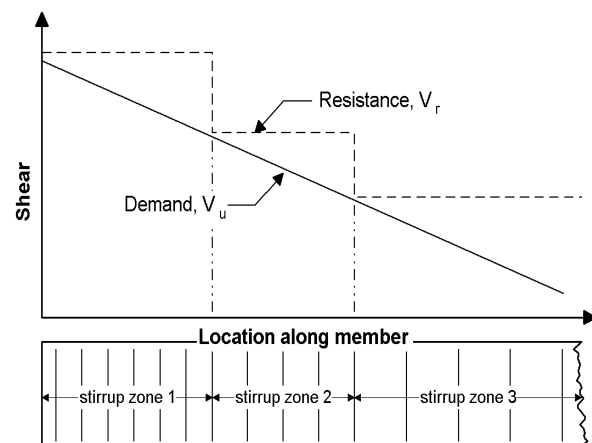

Figure C5.8.3.2-1—Traditional Shear Design

For typical cases where the applied load acts at or above the middepth of the member, it is more practical to take the traditional approach as shown in Figure C5.8.3.2-1 or a more liberal yet conservative approach as shown in Figure C5.8.3.2-2. The approach taken in Figure C5.8.3.2-2 has the effect of extending the required stirrup spacing for a distance of $0.5d_v \cot \theta$ toward the bearing.

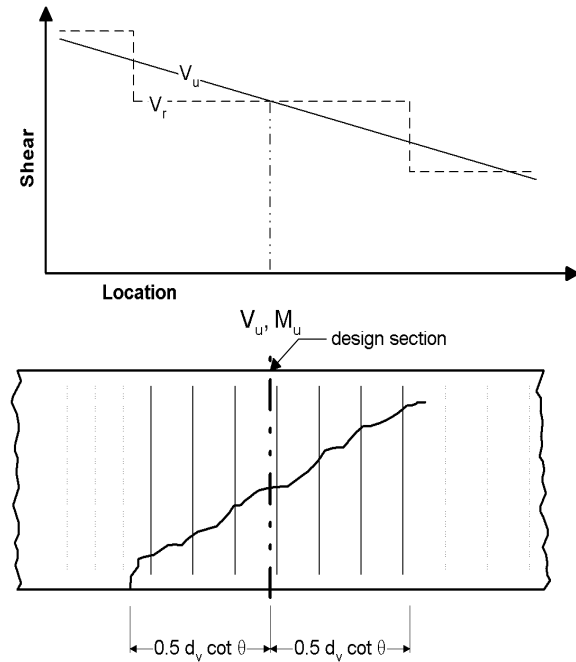

Figure C5.8.3.2-2—Simplified Design Section for Loads Applied at or above the Middepth of the Member

Figure C5.8.3.2-3 shows a case where an inverted T-beam acts as a pier cap and the longitudinal members are supported by the flange of the T. In this case, a significant amount of the load is applied below the middepth of the member, and it is more appropriate to use the traditional approach to shear design shown in Figure C5.8.3.2-1.

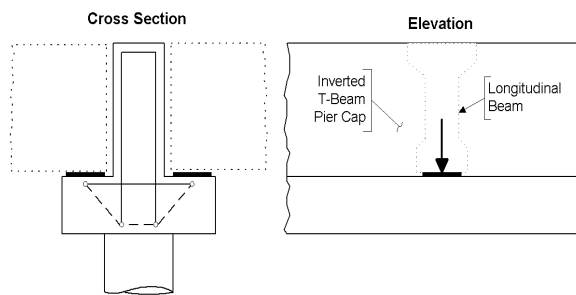

Figure C5.8.3.2-3—Inverted T-Beam Pier Cap

If the shear stress at the design section calculated in accordance with Article 5.8.2.9 exceeds $0.18f'_c$ and the beam-type element is not built integrally with the support, its end region shall be designed using the strut-and-tie model specified in Article 5.6.3.

5.8.3.3—Nominal Shear Resistance

The nominal shear resistance, V_n , shall be determined as the lesser of:

$$V_n = V_c + V_s + V_p \quad (5.8.3.3-1)$$

$$V_n = 0.25f'_c b_v d_v + V_p \quad (5.8.3.3-2)$$

in which:

$$V_c = 0.0316\beta\sqrt{f'_c} b_v d_v, \text{ if the procedures of Articles 5.8.3.4.1 or 5.8.3.4.2 are used} \quad (5.8.3.3-3)$$

V_c = the lesser of V_{ci} and V_{cw} , if the procedures of Article 5.8.3.4.3 are used

$$V_s = \frac{A_v f_y d_v (\cot \theta + \cot \alpha) \sin \alpha}{s} \quad (5.8.3.3-4)$$

Where transverse reinforcement consists of a single longitudinal bar or a single group of parallel longitudinal bars bent up at the same distance from the support, the shear resistance V_s provided by these bars shall be determined as:

$$V_s = A_v f_y \sin \alpha \leq 0.095\sqrt{f'_c} b_v d_v \quad (5.8.3.3-5)$$

where:

- b_v = effective web width taken as the minimum web width within the depth d_v as determined in Article 5.8.2.9 (in.)
- d_v = effective shear depth as determined in Article 5.8.2.9 (in.)
- s = spacing of transverse reinforcement measured in a direction parallel to the longitudinal reinforcement (in.)
- β = factor indicating ability of diagonally cracked concrete to transmit tension and shear as specified in Article 5.8.3.4

The T-beam pier cap shown in Figure C5.8.3.2-3 acts as a beam ledge and should be designed for the localized effects caused by the concentrated load applied to the T-beam flange. Provisions for beam ledge design are given in Article 5.13.2.5.

Where a beam is loaded on top and its end is not built integrally into the support, all the shear funnels down into the end bearing. Where the beam has a thin web so that the shear stress in the beam exceeds $0.18f'_c$, there is the possibility of a local diagonal compression or horizontal shear failure along the interface between the web and the lower flange of the beam. Usually the inclusion of additional transverse reinforcement cannot prevent this type of failure and either the section size must be increased or the end of the beam designed using a strut-and-tie model.

C5.8.3.3

The shear resistance of a concrete member may be separated into a component, V_c , that relies on tensile stresses in the concrete, a component, V_s , that relies on tensile stresses in the transverse reinforcement, and a component, V_p , that is the vertical component of the prestressing force.

The expressions for V_c and V_s apply to both prestressed and nonprestressed sections, with the terms β and θ depending on the applied loading and the properties of the section.

The upper limit of V_n , given by Eq. 5.8.3.3-2, is intended to ensure that the concrete in the web of the beam will not crush prior to yield of the transverse reinforcement.

where $\alpha = 90$ degrees, Eq. 5.8.3.3-4 reduces to:

$$V_s = \frac{A_v f_y d_v \cot \theta}{s} \quad (C5.8.3.3-1)$$

- θ = angle of inclination of diagonal compressive stresses as determined in Article 5.8.3.4 (degrees); if the procedures of Article 5.8.3.4.3 are used, $\cot \theta$ is defined therein
- α = angle of inclination of transverse reinforcement to longitudinal axis (degrees)
- A_v = area of shear reinforcement within a distance s (in.²)
- V_p = component in the direction of the applied shear of the effective prestressing force; positive if resisting the applied shear; $V_p = 0$ when Article 5.8.3.4.3 is applied (kip)

Where bent longitudinal reinforcement is used, only the center three-fourths of the inclined portion of the bent bar shall be considered effective for transverse reinforcement.

Where more than one type of transverse reinforcement is used to provide shear resistance in the same portion of a member, the shear resistance V_s shall be determined as the sum of V_s values computed from each type.

Where shear resistance is provided by bent longitudinal reinforcement or a combination of bent longitudinal reinforcement and stirrups, the nominal shear resistance shall be determined using the simplified procedure in accordance with Article 5.8.3.4.1.

5.8.3.4—Procedures for Determining Shear Resistance

Design for shear may utilize any of the three methods identified herein provided that all requirements for usage of the chosen method are satisfied.

The angle θ is, therefore, also taken as the angle between a strut and the longitudinal axis of a member.

V_p is part of V_{cw} by the method in Article 5.8.3.4.3 and thus V_p need be taken as zero in Eq. 5.8.3.3-1.

Requirements for bent bars were added to make the provisions consistent with those in AASHTO (2002).

C5.8.3.4

Three complementary methods are given for evaluating shear resistance. Method 1, specified in Article 5.8.3.4.1, as described herein, is only applicable for nonprestressed sections. Method 2, as described in Article 5.8.3.4.2, is applicable for all prestressed and nonprestressed members, with and without shear reinforcement, with and without axial load. Two approaches are presented in Method 2: a direct calculation, specified in Article 5.8.3.4.2, and an evaluation using tabularized values presented in Appendix B5. The approaches to Method 2 may be considered statistically equivalent. Method 3, specified in Article 5.8.3.4.3, is applicable for both prestressed and nonprestressed sections in which there is no net axial tensile load and at least minimum shear reinforcement is provided. Axial load effects can otherwise be accounted for through adjustments to the level of effective precompression stress, f_{pc} . In regions of overlapping applicability between the latter two methods, Method 3 will generally lead to somewhat more shear reinforcement being required, particularly in areas of negative moment and near points of contraflexure. If Method 3 leads to an unsatisfactory rating, it is permissible to use Method 2.

5.8.3.4.1—Simplified Procedure for Nonprestressed Sections

For concrete footings in which the distance from point of zero shear to the face of the column, pier or wall is less than $3d_v$, with or without transverse reinforcement, and for other nonprestressed concrete sections not subjected to axial tension and containing at least the minimum amount of transverse reinforcement specified in Article 5.8.2.5, or having an overall depth of less than 16.0 in., the following values may be used:

$$\begin{aligned}\beta &= 2.0 \\ \theta &= 45^\circ\end{aligned}$$

5.8.3.4.2—General Procedure

The parameters β and θ may be determined either by the provisions herein, or alternatively by the provisions of Appendix B5.

For sections containing at least the minimum amount of transverse reinforcement specified in Article 5.8.2.5, the value of β may be determined by Eq. 5.8.3.4.2-1:

$$\beta = \frac{4.8}{(1 + 750\varepsilon_s)} \quad (5.8.3.4.2-1)$$

When sections do not contain at least the minimum amount of shear reinforcement, the value of β may be as specified in Eq. 5.8.3.4.2-2:

$$\beta = \frac{4.8}{(1 + 750\varepsilon_s)} \frac{51}{(39 + s_{xe})} \quad (5.8.3.4.2-2)$$

The value of θ in both cases may be as specified in Eq. 5.8.3.4.2-3:

$$\theta = 29 + 3500\varepsilon_s \quad (5.8.3.4.2-3)$$

In Eqs. 5.8.3.4.2-1 through 5.8.3.4.2-3, ε_s is the net longitudinal tensile strain in the section at the centroid of the tension reinforcement as shown in Figures 5.8.3.4.2-1 and 5.8.3.4.2-2. In lieu of more involved procedures, ε_s may be determined by Eq. 5.8.3.4.2-4:

$$\varepsilon_s = \frac{\left(\frac{|M_u|}{d_v} + 0.5N_u + |V_u - V_p| - A_{ps}f_{po} \right)}{E_s A_s + E_p A_{ps}} \quad (5.8.3.4.2-4)$$

The crack spacing parameter, s_{xe} , shall be determined as:

$$s_{xe} = s_x \frac{1.38}{a_g + 0.63} \quad (5.8.3.4.2-5)$$

where:

C5.8.3.4.1

With β taken as 2.0 and θ as 45 degrees, the expressions for shear strength become essentially identical to those traditionally used for evaluating shear resistance. Recent large-scale experiments (Shioya et al., 1989), however, have demonstrated that these traditional expressions can be seriously unconservative for large members not containing transverse reinforcement.

C5.8.3.4.2

The shear resistance of a member may be determined by performing a detailed sectional analysis that satisfies the requirements of Article 5.8.3.1. Such an analysis, see Figure C5.8.3.4.2-1, would show that the shear stresses are not uniform over the depth of the web and that the direction of the principal compressive stresses changes over the depth of the beam. The more direct procedure given herein assumes that the concrete shear stresses are uniformly distributed over an area b_v wide and d_v deep, that the direction of principal compressive stresses (defined by angle θ and shown as D) remains constant over d_v , and that the shear strength of the section can be determined by considering the biaxial stress conditions at just one location in the web. See Figure C5.8.3.4.2-2.

This design procedure (Collins et al, 1994) was derived from the Modified Compression Field Theory (MCFT, Vecchio, and Collins, 1986) which is a comprehensive behavioral model for the response of diagonally cracked concrete subject to in-plane shear and normal stresses. Prior to the 2008 interim revisions, the General Procedure for shear design was iterative and required the use of tables for the evaluation of β and θ . With the 2008 revisions, this design procedure was modified to be non-iterative and algebraic equations were introduced for the evaluation of β and θ . These equations are functionally equivalent to those used in the Canadian design code (A23.2-M04, 2004), were also derived from the MCFT (Bentz et al. 2006), and were evaluated as appropriate for use in the *AASHTO LRFD Bridge Design Specifications* (Hawkins et al., 2006, 2007).

The longitudinal strain, ε_s , can be determined by the procedure illustrated in Figure C5.8.3.4.2-3. The actual section is represented by an idealized section consisting of a flexural tension flange, a flexural compression flange, and a web. The area of the compression flange is taken as the area on the flexure compression side of the member, i.e., the total area minus the area of the tension flange as defined by A_c . After diagonal cracks have formed in the web, the shear force applied to the web concrete, $V_u - V_p$, will primarily be carried by diagonal compressive stresses in the web concrete.

$$12.0 \text{ in.} \leq s_{xe} \leq 80.0 \text{ in.}$$

where:

- A_c = area of concrete on the flexural tension side of the member as shown in Figure 5.8.3.4.2-1 (in.²)
- A_{ps} = area of prestressing steel on the flexural tension side of the member, as shown in Figure 5.8.3.4.2-1 (in.²)
- A_s = area of nonprestressed steel on the flexural tension side of the member at the section under consideration, as shown in Figure 5.8.3.4.2-1 (in.²)
- a_g = maximum aggregate size (in.)
- f_{po} = a parameter taken as modulus of elasticity of prestressing tendons multiplied by the locked-in difference in strain between the prestressing tendons and the surrounding concrete (ksi). For the usual levels of prestressing, a value of $0.7 f_{pu}$ will be appropriate for both pretensioned and post-tensioned members
- N_u = factored axial force, taken as positive if tensile and negative if compressive (kip)
- $|M_u|$ = absolute value of the factored moment, not to be taken less than $|V_u - V_p| d_v$ (kip-in.)
- s_x = the lesser of either d_v or the maximum distance between layers of longitudinal crack control reinforcement, where the area of the reinforcement in each layer is not less than $0.003b_v s_{xv}$ as shown in Figure 5.8.3.4.2-3 (in.)
- V_u = factored shear force (kip)

Within the transfer length, f_{po} shall be increased linearly from zero at the location where the bond between the strands and concrete commences to its full value at the end of the transfer length.

The flexural tension side of the member shall be taken as the half-depth containing the flexural tension zone, as illustrated in Figure 5.8.3.4.2-1.

In the use of Eqs. 5.8.3.4.2-1 through 5.8.3.4.2-5, the following should be considered:

- $|M_u|$ should not be taken less than $|V_u - V_p| d_v$.
- In calculating A_s and A_{ps} the area of bars or tendons terminated less than their development length from the section under consideration should be reduced in proportion to their lack of full development.
- If the value of ϵ_s calculated from Eq. 5.8.3.4.2-4 is negative, it should be taken as zero or the value should be recalculated with the denominator of Eq. 5.8.3.4.2-4 replaced by $(E_s A_s + E_p A_{ps} + E_c A_{ct})$. However, ϵ_s should not be taken as less than -0.40×10^{-3} .

These diagonal compressive stresses will result in a longitudinal compressive force in the web concrete of $(V_u - V_p) \cot \theta$. Equilibrium requires that this longitudinal compressive force in the web needs to be balanced by tensile forces in the two flanges, with half the force, that is $0.5 (V_u - V_p) \cot \theta$, being taken by each flange. For simplicity, $0.5 \cot \theta$ may be taken as $= 2.0$ and the longitudinal demand due to shear in the longitudinal tension reinforcement becomes $V_u - V_p$ without significant loss of accuracy. After the required axial forces in the two flanges are calculated, the resulting axial strains, ϵ_t and ϵ_c , can be calculated based on the axial force-axial strain relationship shown in Figure C5.8.3.4.2-3.

For pretensioned members, f_{po} can be taken as the stress in the strands when the concrete is cast around them, i.e., approximately equal to the jacking stress. For post-tensioned members, f_{po} can be conservatively taken as the average stress in the tendons when the post-tensioning is completed.

- For sections closer than d_v to the face of the support, the value of ϵ_s calculated at d_v from the face of the support may be used in evaluating β and θ .
- If the axial tension is large enough to crack the flexural compression face of the section, the value calculated from Eq. 5.8.3.4.2-4 should be doubled.
- It is permissible to determine β and θ from Eqs. 5.8.3.4.2-1 through 5.8.3.4.2-3 using a value of ϵ_s which is greater than that calculated from Eq. 5.8.3.4.2-4. However ϵ_s should not be taken greater than 6.0×10^{-3} .

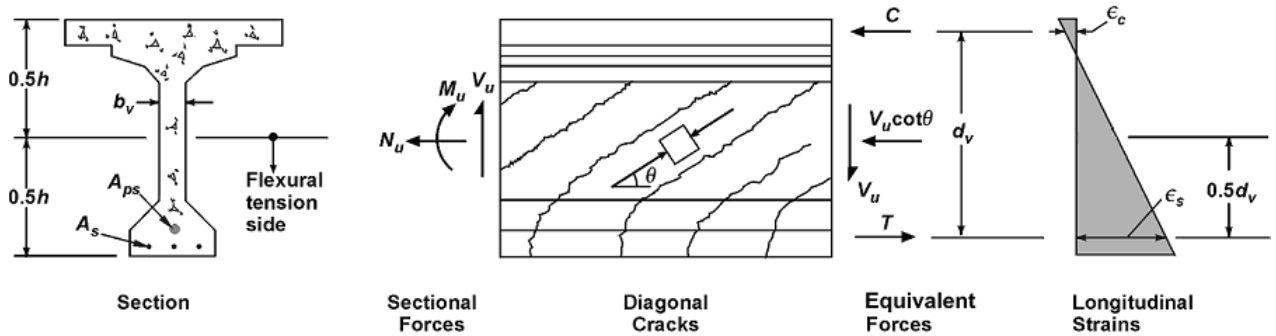

Figure 5.8.3.4.2-1—Illustration of Shear Parameters for Section Containing at Least the Minimum Amount of Transverse Reinforcement, $V_p = 0$

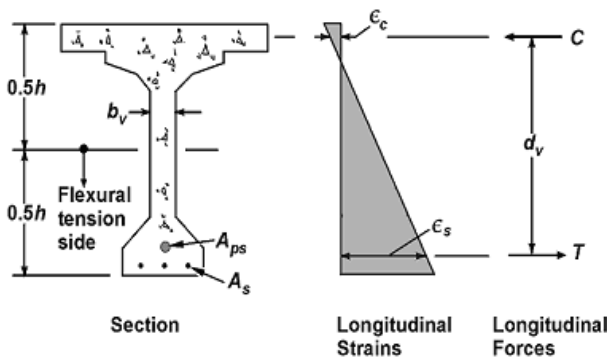
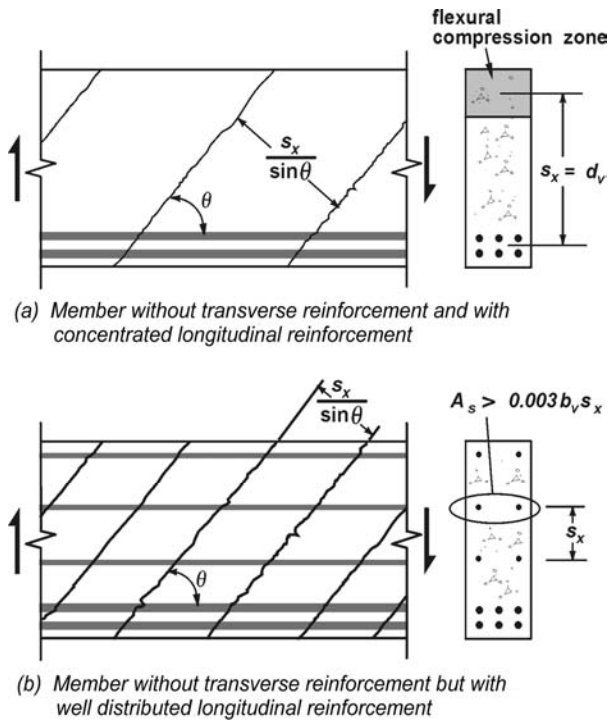

Figure 5.8.3.4.2-2—Longitudinal Strain, ϵ_s , for Sections Containing Less than the Minimum Amount of Transverse Reinforcement



The relationships for evaluating β and θ in Eqs. 5.8.3.4.2-1 and 5.8.3.4.2-2 are based on calculating the stresses that can be transmitted across diagonally cracked concrete. As the cracks become wider, the stress that can be transmitted decreases. For members containing at least the minimum amount of transverse reinforcement, it is assumed that the diagonal cracks will be spaced about 12.0 in. apart. For members without transverse reinforcement, the spacing of diagonal cracks inclined at θ degrees to the longitudinal reinforcement is assumed to be $s_x/\sin \theta$, as shown in Figure 5.8.3.4.2-3. Hence, deeper members having larger values of s_x are calculated to have more widely spaced cracks and hence, cannot transmit such high shear stresses. The ability of the crack surfaces to transmit shear stresses is influenced by the aggregate size of the concrete. Members made from concretes that have a smaller maximum aggregate size will have a larger value of s_{xe} and hence, if there is no transverse reinforcement, will have a smaller shear strength.

Figure 5.8.3.4.2-3—Definition of Crack Spacing Parameter, s_x

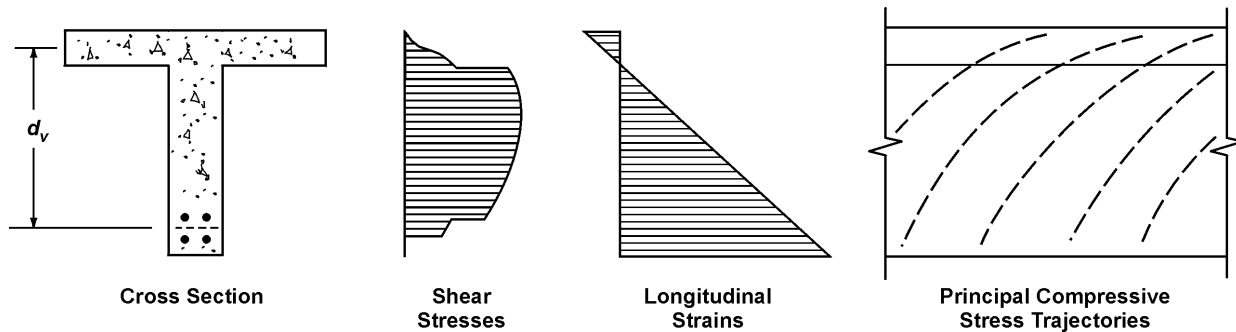

Figure C5.8.3.4.2-1—Detailed Sectional Analysis to Determine Shear Resistance in Accordance with Article 5.8.3.1

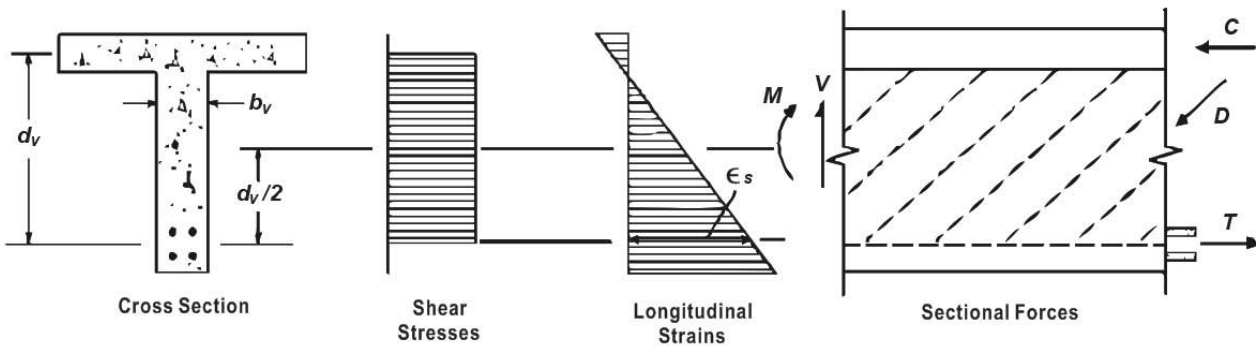

Figure C5.8.3.4.2-2—More Direct Procedure to Determine Shear Resistance in Accordance with Article 5.8.3.4.2

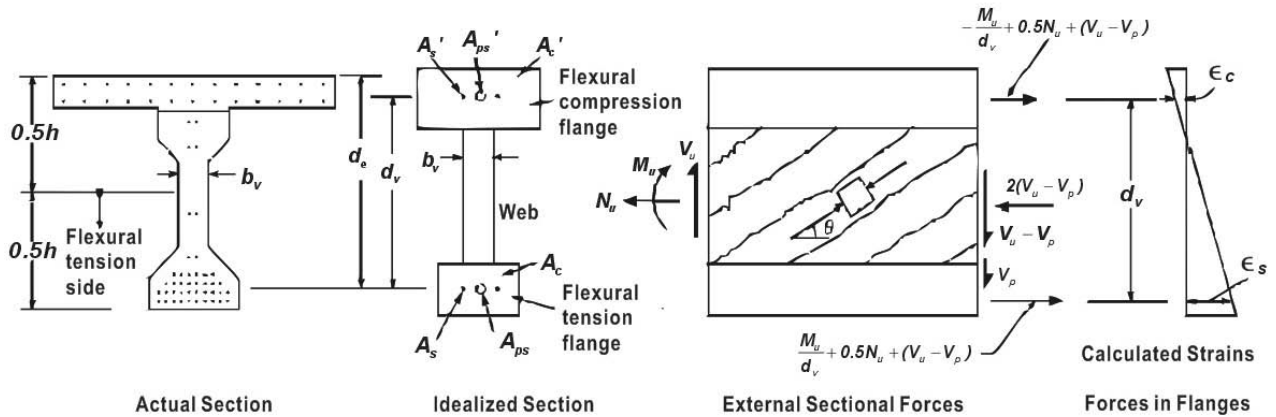

Figure C5.8.3.4.2-3—More Accurate Calculation Procedure for Determining ϵ_s

5.8.3.4.3—Simplified Procedure for Prestressed and Nonprestressed Sections

C5.8.3.4.3

For concrete beams not subject to significant axial tension, prestressed and nonprestressed, and containing at least the minimum amount of transverse reinforcement specified in Article 5.8.2.5, V_n in Article 5.8.3.3 may be determined with V_p taken as zero and V_c taken as the lesser of V_{ci} and V_{cw} , where:

V_{ci} = nominal shear resistance provided by concrete when inclined cracking results from combined shear and moment (kip)

V_{cw} = nominal shear resistance provided by concrete when inclined cracking results from excessive principal tensions in web (kip)

V_{ci} shall be determined as:

$$V_{ci} = 0.02\sqrt{f'_c}b_v d_v + V_d + \frac{V_i M_{cre}}{M_{max}} \geq 0.06\sqrt{f'_c}b_v d_v \quad (5.8.3.4.3-1)$$

Article 5.8.3.4.3 is based on the recommendations of NCHRP Report 549 (Hawkins et al., 2005). The concepts of this Article are compatible with the concepts of ACI Code 318-05 and AASHTO *Standard Specifications for Highway Bridges* (2002) for evaluations of the shear resistance of prestressed concrete members. However, those concepts are modified so that this Article applies to both prestressed and nonprestressed sections.

The nominal shear resistance V_n is the sum of the shear resistances V_c and V_s provided by the concrete and shear reinforcement, respectively. Both V_c and V_s depend on the type of inclined cracking that occurs at the given section. There are two types of inclined cracking: flexure-shear cracking and web-shear cracking for which the associated resistances are V_{ci} and V_{cw} , respectively. Figure C5.8.3.4.3-1 shows the development of both types of cracking when increasing uniform load was applied to a 63-in. bulb-tee girder. NCHRP Report XX2 (Hawkins et al., 2005).

where:

- V_d = shear force at section due to unfactored dead load and includes both DC and DW (kip)
- V_i = factored shear force at section due to externally applied loads occurring simultaneously with M_{max} (kip)
- M_{cre} = moment causing flexural cracking at section due to externally applied loads (kip-in)
- M_{max} = maximum factored moment at section due to externally applied loads (kip-in)

M_{cre} shall be determined as:

$$M_{cre} = S_c \left(f_r + f_{cpe} - \frac{M_{dnc}}{S_{nc}} \right) \quad (5.8.3.4.3-2)$$

where:

- f_{cpe} = compressive stress in concrete due to effective prestress forces only (after allowance for all prestress losses) at extreme fiber of section where tensile stress is caused by externally applied loads (ksi)
- M_{dnc} = total unfactored dead load moment acting on the monolithic or noncomposite section (kip-in.)
- S_c = section modulus for the extreme fiber of the composite section where tensile stress is caused by externally applied loads (in.³)
- S_{nc} = section modulus for the extreme fiber of the monolithic or noncomposite section where tensile stress is caused by externally applied loads (in.³)

In Eq. 5.8.3.4.3-1, M_{max} and V_i shall be determined from the load combination causing maximum moment at the section.

V_{cw} shall be determined as:

$$V_{cw} = (0.06\sqrt{f'_c} + 0.30f_{pc})b_v d_v + V_p \quad (5.8.3.4.3-3)$$

where:

- f_{pc} = compressive stress in concrete (after allowance for all prestress losses) at centroid of cross section resisting externally applied loads or at junction of web and flange when the centroid lies within the flange (ksi). In a composite member, f_{pc} is the resultant compressive stress at the centroid of the composite section, or at junction of web and flange, due to both

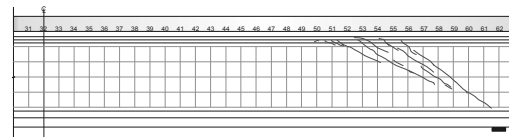

(a) Load 1

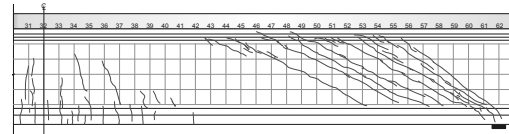

(b) Load 2

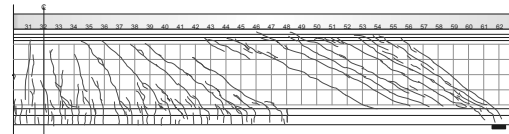

(c) Load 3

Figure C5.8.3.4.3-1—Development of Shear Cracking with Increasing Loads for Uniformly Loaded Bulb Tee Beam; Load 1 < Load 2 < Load 3

Web-shear cracking begins from an interior point in the web of the member before either flange in that region cracks in flexure. In Figure C5.8.3.4.3-1, at load 1, web-shear cracking developed in the web of the member adjacent to the end support. Flexure-shear cracking is initiated by flexural cracking. Flexural cracking increases the shear stresses in the concrete above the flexural crack. In Figure C5.8.3.4.3-1, flexural cracking had developed in the central region of the beam by load 2 and by load 3, the flexural cracks had become inclined cracks as flexural cracking extended towards the end support with increasing load.

For sections with shear reinforcement equal to or greater than that required by Article 5.8.2.5, the shear carried by the concrete may drop below V_c shortly after inclined cracking, and the shear reinforcement may yield locally. However, sections continue to resist increasing shears until resistances provided by the concrete again reach V_c . Thus, V_{ci} and V_{cw} are measures of the resistance that can be provided by the concrete at the nominal shear resistance of the section and are not directly equal to the shears at inclined cracking.

The angle θ of the inclined crack, and therefore of the diagonal compressive stress, is less for a web-shear crack than a flexure-shear crack. Consequently, for a given section the value of V_s associated with web-shear cracking is greater than that associated with flexure-shear cracking.

V_{ci} is the sum of the shear ($V_i M_{cr} / M_{max}$) required to cause flexural cracking at the given section plus the increment of shear necessary to develop the flexural crack into a shear crack. For a non-composite beam, the total cross section resists all applied shears, dead and live, I_c equals the moment of inertia of the gross section and V_d equals the unfactored dead load shear acting on the section. In this case Eq. 5.8.3.4.3-1 can be used directly.

prestress and moments resisted by precast member acting alone.

V_s shall be determined using Eq. 5.8.3.3-4 with $\cot \theta$ taken as follows:

where $V_{ci} < V_{cw}$:

$$\cot \theta = 1.0$$

where $V_{ci} > V_{cw}$:

$$\cot \theta = 1.0 + 3 \left(\frac{f_{pc}}{\sqrt{f'_c}} \right) \leq 1.8 \quad (5.8.3.4.3-4)$$

For a composite beam, part of the dead load is resisted by only part of the final section. Where the final gross concrete section is achieved with only one addition to the initial concrete section (two-stage construction), Eq. 5.8.3.4.3-1 can be used directly. In Eq. 5.8.3.4.3-2 appropriate section properties are used to compute f_d and in Eq. 5.8.3.4.3-1 the shear due to dead load V_d and that due to other loads V_i are separated. V_d is the total shear force due to unfactored dead loads acting on the part of the section carrying the dead loads acting prior to composite action plus the unfactored superimposed dead load acting on the composite member. The term V_i may be taken as $(V_u - V_d)$ and M_{max} as $M_u - M_d$ where V_u and M_u are the factored shear and moment at the given section due to the total factored loads M_d is the moment due to unfactored dead load at the same section.

Where the final gross section is developed with more than one concrete composite addition to the initial section (multiple-stage construction), it is necessary to trace the build up of the extreme fiber flexural stresses to compute M_{cr} . For each stage in the life history of the member, the increments in the extreme fiber flexural stress at the given section due to the unfactored loads acting on that section are calculated using the section properties existing at that stage. V_d , V_i , and M_{max} are calculated in the same manner as for two-stage construction.

A somewhat lower modulus of rupture is used in evaluating M_{cre} by Eq. 5.8.3.4.3-2 to account for the effects of differential shrinkage between the slab and the girder, and the effects of thermal gradients that can occur over the depth of the girder.

5.8.3.5—Longitudinal Reinforcement

At each section the tensile capacity of the longitudinal reinforcement on the flexural tension side of the member shall be proportioned to satisfy:

$$A_{ps}f_{ps} + A_s f_y \geq \frac{|M_u|}{d_v \phi_f} + 0.5 \frac{N_u}{\phi_c} + \left(\left| \frac{V_u}{\phi_v} - V_p \right| - 0.5V_s \right) \cot \theta \quad (5.8.3.5-1)$$

where:

V_s = shear resistance provided by the transverse reinforcement at the section under investigation as given by Eq. 5.8.3.3-4, except V_s shall not be taken as greater than V_u/ϕ (kip)

C5.8.3.5

Shear causes tension in the longitudinal reinforcement. For a given shear, this tension becomes larger as θ becomes smaller and as V_c becomes larger. The tension in the longitudinal reinforcement caused by the shear force can be visualized from a free-body diagram such as that shown in Figure C5.8.3.5-1.

Taking moments about Point 0 in Figure C5.8.3.5-1, assuming that the aggregate interlock force on the crack, which contributes to V_c , has a negligible moment about Point 0, and neglecting the small difference in location of V_u and V_p leads to the requirement for the tension force in the longitudinal reinforcement caused by shear.

θ = angle of inclination of diagonal compressive stresses used in determining the nominal shear resistance of the section under investigation as determined by Article 5.8.3.4 (degrees); if the procedures of Article 5.8.3.4.3 are used, $\cot \theta$ is defined therein

ϕ, ϕ_v, ϕ_c = resistance factors taken from Article 5.5.4.2 as appropriate for moment, shear and axial resistance

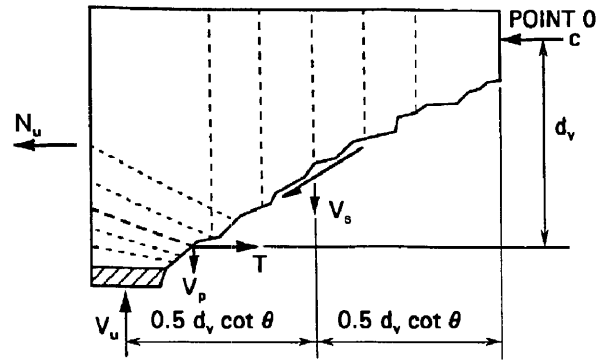

Figure C5.8.3.5-1—Forces Assumed in Resistance Model Caused by Moment and Shear

The area of longitudinal reinforcement on the flexural tension side of the member need not exceed the area required to resist the maximum moment acting alone. This provision applies where the reaction force or the load introduces direct compression into the flexural compression face of the member.

Eq. 5.8.3.5-1 shall be evaluated where simply-supported girders are made continuous for live loads. Where longitudinal reinforcement is discontinuous, Eq. 5.8.3.5-1 shall be re-evaluated.

At maximum moment locations, the shear force changes sign, and hence the inclination of the diagonal compressive stresses changes. At direct supports including simply-supported girder ends and bent/pier caps pinned to columns, and at loads applied directly to the top or bottom face of the member, this change of inclination is associated with a fan-shaped pattern of compressive stresses radiating from the point load or the direct support as shown in Figure C5.8.3.5-2. This fanning of the diagonal stresses reduces the tension in the longitudinal reinforcement caused by the shear; i.e., angle θ becomes steeper. The tension in the reinforcement does not exceed that due to the maximum moment alone. Hence, the longitudinal reinforcement requirements can be met by extending the flexural reinforcement for a distance of $d_v \cot \theta$ or as specified in Article 5.11, whichever is greater.

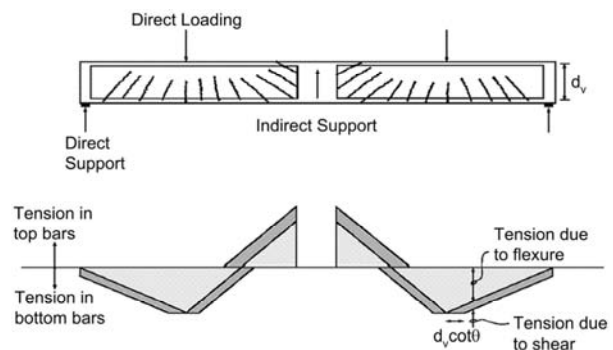

Figure C5.8.3.5-2—Force Variation in Longitudinal Reinforcement Near Maximum Moment Locations

At the inside edge of the bearing area of simple end supports to the section of critical shear, the longitudinal reinforcement on the flexural tension side of the member shall satisfy:

$$A_s f_y + A_{ps} f_{ps} \geq \left(\frac{V_u}{\phi_v} - 0.5V_s - V_p \right) \cot \theta \quad (5.8.3.5-2)$$

Eqs. 5.8.3.5-1 and 5.8.3.5-2 shall be taken to apply to sections not subjected to torsion. Any lack of full development shall be accounted for.

5.8.3.6—Sections Subjected to Combined Shear and Torsion

5.8.3.6.1—Transverse Reinforcement

The transverse reinforcement shall not be less than the sum of that required for shear, as specified in Article 5.8.3.3, and for the concurrent torsion, as specified in Articles 5.8.2.1 and 5.8.3.6.2.

5.8.3.6.2—Torsional Resistance

The nominal torsional resistance shall be taken as:

$$T_n = \frac{2A_o A_t f_y \cot \theta}{s} \quad (5.8.3.6.2-1)$$

where:

- A_o = area enclosed by the shear flow path, including any area of holes therein (in.²)
- A_t = area of one leg of closed transverse torsion reinforcement in solid members, or total area of transverse torsion reinforcement in the exterior web of cellular members (in.²)
- θ = angle of crack as determined in accordance with the provisions of Article 5.8.3.4 with the modifications to the expressions for v and V_u herein (degrees)

5.8.3.6.3—Longitudinal Reinforcement

The provisions of Article 5.8.3.5 shall apply as amended, herein, to include torsion.

The longitudinal reinforcement in solid sections shall be proportioned to satisfy Eq. 5.8.3.6.3-1:

In determining the tensile force that the reinforcement is expected to resist at the inside edge of the bearing area, the values of V_u , V_s , V_p , and θ , calculated for the section d_v from the face of the support may be used. In calculating the tensile resistance of the longitudinal reinforcement, a linear variation of resistance over the development length of Article 5.11.2.1.1 or the bi-linear variation of resistance over the transfer and development length of Article 5.11.4.2 may be assumed.

C5.8.3.6.1

The shear stresses due to torsion and shear will add on one side of the section and offset on the other side. The transverse reinforcement is designed for the side where the effects are additive.

Usually the loading that causes the highest torsion differs from the loading that causes the highest shear. Although it is sometimes convenient to design for the highest torsion combined with the highest shear, it is only necessary to design for the highest shear and its concurrent torsion, and the highest torsion and its concurrent shear.

C5.8.3.6.3

To account for the fact that on one side of the section the torsional and shear stresses oppose each other, the equivalent tension used in the design equation is taken as the square root of the sum of the squares of the individually calculated tensions in the web.

$$A_{ps} f_{ps} + A_s f_y \geq \frac{|M_u|}{\phi d_v} + \frac{0.5N_u}{\phi} + \cot \theta \sqrt{\left(\left| \frac{V_u}{\phi} - V_p \right| - 0.5V_s \right)^2 + \left(\frac{0.45 p_h T_u}{2A_o \phi} \right)^2} \quad (5.8.3.6.3-1)$$

In box sections, longitudinal reinforcement for torsion, in addition to that required for flexure, shall not be less than:

$$A_t = \frac{T_n p_h}{2A_o f_y} \quad (5.8.3.6.3-2)$$

where:

p_h = perimeter of the centerline of the closed transverse torsion reinforcement (in.)

5.8.4—Interface Shear Transfer—Shear Friction

5.8.4.1—General

Interface shear transfer shall be considered across a given plane at:

- An existing or potential crack,
- An interface between dissimilar materials,
- An interface between two concretes cast at different times, or
- The interface between different elements of the cross-section.

C5.8.4.1

Shear displacement along an interface plane may be resisted by cohesion, aggregate interlock, and shear-friction developed by the force in the reinforcement crossing the plane of the interface. Roughness of the shear plane causes interface separation in a direction perpendicular to the interface plane. This separation induces tension in the reinforcement balanced by compressive stresses on the interface surfaces.

Adequate shear transfer reinforcement must be provided perpendicular to the vertical planes of web/flange interfaces in box girders to transfer flange longitudinal forces at the strength limit state. The factored design force for the interface reinforcement is calculated to account for the interface shear force, ΔF , as shown in Figure C5.8.4.1-1, as well as any localized shear effects due to the prestressing force anchorages at the section.

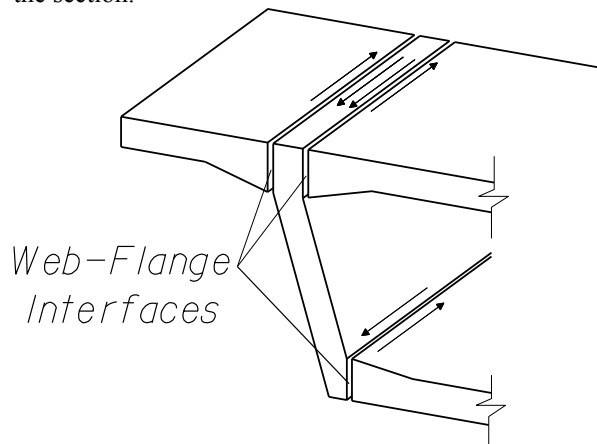

Figure C5.8.4.1-1—Longitudinal Shear Transfer between Flanges and Webs of Box Girder Bridges

Reinforcement for interface shear may consist of single bars, multiple leg stirrups, or welded wire fabric.

All reinforcement present where interface shear transfer is to be considered shall be fully developed on both sides of the interface by embedment, hooks, mechanical methods such as headed studs or welding to develop the design yield stress.

The minimum area of interface shear reinforcement specified in Article 5.8.4.4 shall be satisfied.

The factored interface shear resistance, V_{ri} , shall be taken as:

$$V_{ri} = \phi V_{ni} \quad (5.8.4.1-1)$$

and the design shall satisfy:

$$V_{ri} \geq V_{ui} \quad (5.8.4.1-2)$$

where:

- V_{ni} = nominal interface shear resistance (kip)
- V_{ui} = factored interface shear force due to total load based on the applicable strength and extreme event load combinations in Table 3.4.1-1 (kip)
- ϕ = resistance factor for shear specified in Article 5.5.4.2.1. In cases where different weight concretes exist on the two sides of an interface, the lower of the two values of ϕ shall be used.

The nominal shear resistance of the interface plane shall be taken as:

$$V_{ni} = cA_{cv} + \mu (A_{vf}f_y + P_c) \quad (5.8.4.1-3)$$

The nominal shear resistance, V_{ni} , used in the design shall not be greater than the lesser of:

$$V_{ni} \leq K_1 f'_c A_{cv}, \text{ or} \quad (5.8.4.1-4)$$

$$V_{ni} \leq K_2 A_{cv} \quad (5.8.4.1-5)$$

in which:

$$A_{cv} = b_{vi} L_{vi} \quad (5.8.4.1-6)$$

Any reinforcement crossing the interface is subject to the same strain as the designed interface reinforcement. Insufficient anchorage of any reinforcement crossing the interface could result in localized fracture of the surrounding concrete.

When the required interface shear reinforcement in girder/slab design exceeds the area required to satisfy vertical (transverse) shear requirements, additional reinforcement must be provided to satisfy the interface shear requirements. The additional interface shear reinforcement need only extend into the girder a sufficient depth to develop the design yield stress of the reinforcement rather than extending the full depth of the girder as is required for vertical shear reinforcement.

Total load shall include all noncomposite and composite loads.

For the extreme limit state event ϕ may be taken as 1.0.

A pure shear friction model assumes interface shear resistance is directly proportional to the net normal clamping force ($A_{vf}f_y + P_c$), through a friction coefficient (μ). Eq. 5.8.4.1-3 is a modified shear-friction model accounting for a contribution, evident in the experimental data, from cohesion and/or aggregate interlock depending on the nature of the interface under consideration given by the first term. For simplicity, the term “cohesion factor” is used throughout the body of this Article to capture the effects of cohesion and/or aggregate interlock such that Eq. 5.8.4.1-3 is analogous to the vertical shear resistance expression of $V_c + V_s$.

Eq. 5.8.4.1-4 limits V_{ni} to prevent crushing or shearing of aggregate along the shear plane.

Eqs. 5.8.4.1-3 and 5.8.4.1-4 are sufficient, with an appropriate value for K_1 , to establish a lower bound for the available experimental data; however, Eq. 5.8.4.1-5 is necessitated by the sparseness of available experimental data beyond the limiting K_2 values provided in Article 5.8.4.3.

The interface shear strength Eqs. 5.8.4.1-3, 5.8.4.1-4, and 5.8.4.1-5 are based on experimental data for normal weight, nonmonolithic concrete strengths ranging from 2.5 ksi to 16.5 ksi; normal weight, monolithic concrete strengths from 3.5 ksi to 18.0 ksi; sand-lightweight concrete strengths from 2.0 ksi to 6.0 ksi; and all-lightweight concrete strengths from 4.0 ksi to 5.2 ksi.

Composite section design utilizing full-depth precast deck panels is not addressed by these provisions. Design specifications for such systems should be established by, or coordinated with, the Owner.

A_{vf} used in Eq. 5.8.4.1-3 is the interface shear reinforcement within the interface area A_{cv} . For a girder/slab interface, the area of the interface shear reinforcement per foot of girder length is calculated by replacing A_{cv} in Eq. 5.8.4.1-3 with $12b_{vi}$ and P_c corresponding to the same one foot of girder length.

In consideration of the use of stay-in-place deck panels, or any other interface details, the Designer shall determine the width of interface, b_{vi} , effectively acting to resist interface shear.

The interface reinforcement is assumed to be stressed to its design yield stress, f_y . However, f_y used in determining the interface shear resistance is limited to 60 ksi because interface shear resistance computed using higher values have overestimated the interface shear resistance experimentally determined in a limited number of tests of pre-cracked specimens.

It is conservative to neglect P_c if it is compressive, however, if included, the value of P_c shall be computed as the force acting over the area, A_{cv} . If P_c is tensile, additional reinforcement is required to resist the net tensile force as specified in Article 5.8.4.2.

where:

A_{cv} = area of concrete considered to be engaged in interface shear transfer (in.²)

A_{vf} = area of interface shear reinforcement crossing the shear plane within the area A_{cv} (in.²)

b_{vi} = interface width considered to be engaged in shear transfer (in.)

L_{vi} = interface length considered to be engaged in shear transfer (in.)

c = cohesion factor specified in Article 5.8.4.3 (ksi)

μ = friction factor specified in Article 5.8.4.3 (dim.)

f_y = yield stress of reinforcement but design value not to exceed 60 (ksi)

P_c = permanent net compressive force normal to the shear plane; if force is tensile, $P_c = 0.0$ (kip)

f'_c = specified 28-day compressive strength of the weaker concrete on either side of the interface (ksi)

K_1 = fraction of concrete strength available to resist interface shear, as specified in Article 5.8.4.3.

K_2 = limiting interface shear resistance specified in Article 5.8.4.3 (ksi)

5.8.4.2—Computation of the Factored Interface Shear Force, V_{ui} , for Girder/Slab Bridges

Based on consideration of a free body diagram and utilizing the conservative envelope value of V_{u1} , the factored interface shear stress for a concrete girder/slab bridge may be determined as:

$$V_{ui} = \frac{V_{u1}}{b_{vi}d_v} \quad (5.8.4.2-1)$$

where:

C5.8.4.2

The following illustrates a free body diagram approach to computation of interface shear in a girder/slab bridge. In reinforced concrete, or prestressed concrete, girder bridges, with a cast-in-place slab, horizontal shear forces develop along the interface between the girders and the slab. The classical strength of materials approach, which is based on elastic behavior of the section, has been used successfully in the past to determine the design interface shear force. As

d_v = the distance between the centroid of the tension steel and the mid-thickness of the slab to compute a factored interface shear stress

The factored interface shear force in kips/ft for a concrete girder/slab bridge may be determined as:

$$V_{ui} = v_{ui} A_{cv} = v_{ui} 12b_{vi} \quad (5.8.4.2-2)$$

If the net force, P_c , across the interface shear plane is tensile, additional reinforcement, A_{vpc} , shall be provided as:

$$A_{vpc} = \frac{P_c}{\Phi f_y} \quad (5.8.4.2-3)$$

For beams and girders, the longitudinal spacing of the rows of interface shear transfer reinforcing bars shall not exceed 24.0 in.

an alternative to the classical elastic strength of materials approach, a reasonable approximation of the factored interface shear force at the strength or extreme event limit state for either elastic or inelastic behavior and cracked or uncracked sections, can be derived with the defined notation and the free body diagram shown in Figure C5.8.4.2-1 as follows:

- M_{u2} = maximum factored moment at section 2
- V_1 = the factored vertical shear at section 1 concurrent with M_{u2}
- M_1 = the factored moment at section 1 concurrent with M_{u2}
- Δl = unit length segment of girder
- C_1 = compression force above the shear plane associated with M_1
- C_{u2} = compression force above the shear plane associated with M_{u2}

$$M_{u2} = M_1 + V_1 \Delta l \quad (C5.8.4.2-1)$$

$$C_{u2} = \frac{M_{u2}}{d_v} \quad (C5.8.4.2-2)$$

$$C_{u2} = \frac{M_1}{d_v} + \frac{V_1 \Delta l}{d_v} \quad (C5.8.4.2-3)$$

$$C_1 = \frac{M_1}{d_v} \quad (C5.8.4.2-4)$$

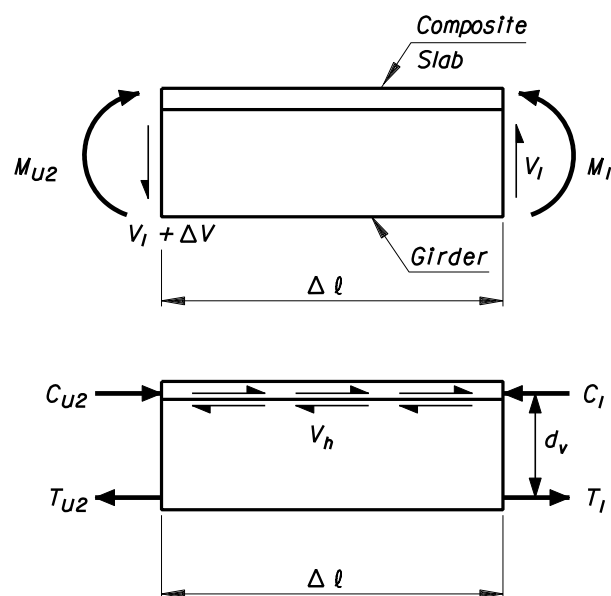

Figure C5.8.4.2-1—Free Body Diagrams

$$V_h = C_{u2} - C_1 \quad (C5.8.4.2-5)$$

$$V_h = \frac{V_1 \Delta l}{d_v} \quad (C5.8.4.2-6)$$

Such that for a unit length segment:

$$V_{hi} = \frac{V_1}{d_v} \quad (\text{C5.8.4.2-7})$$

where:

V_{hi} = factored interface shear force per unit length (kips/length)

The variation of V_1 over the length of any girder segment reflects the shear flow embodied in the classical strength of materials approach. For simplicity of design, V_1 can be conservatively taken as V_{u1} (since V_{u1} , the maximum factored vertical shear at section 1, is not likely to act concurrently with the factored moment at section 2); and further, the depth, d_v , can be taken as the distance between the centroid of the tension steel and the mid-thickness of the slab to compute a factored interface shear stress.

For design purposes, the computed factored interface shear stress of Eq. 5.8.4.2-1 is converted to a resultant interface shear force computed with Eq. 5.8.4.2-1 acting over an area, A_{cv} , within which the computed area of reinforcement, A_{vf} , shall be located. The resulting area of reinforcement, A_{vf} , then defines the area of interface reinforcement required per foot of girder for direct comparison with vertical shear reinforcement requirements.

5.8.4.3—Cohesion and Friction Factors

The following values shall be taken for cohesion, c , and friction factor, μ :

- For a cast-in-place concrete slab on clean concrete girder surfaces, free of laitance with surface roughened to an amplitude of 0.25 in.

$$\begin{aligned} c &= 0.28 \text{ ksi} \\ \mu &= 1.0 \\ K_1 &= 0.3 \\ K_2 &= 1.8 \text{ ksi for normal-weight concrete} \\ &= 1.3 \text{ ksi for lightweight concrete} \end{aligned}$$

- For normal-weight concrete placed monolithically:

$$\begin{aligned} c &= 0.40 \text{ ksi} \\ \mu &= 1.4 \\ K_1 &= 0.25 \\ K_2 &= 1.5 \text{ ksi} \end{aligned}$$

C5.8.4.3

The values presented provide a lower bound of the substantial body of experimental data available in the literature (Loov and Patnaik, 1994; Patnaik, 1999; Mattock, 2001; Slapkus and Kahn, 2004). Furthermore, the inherent redundancy of girder/slab bridges distinguishes this system from other structural interfaces.

The values presented apply strictly to monolithic concrete. These values are not applicable for situations where a crack may be anticipated to occur at a Service Limit State.

The factors presented provide a lower bound of the experimental data available in the literature (Hofbeck, Ibrahim, and Mattock, 1969; Mattock, Li, and Wang, 1976; Mitchell and Kahn, 2001).

- For lightweight concrete placed monolithically, or nonmonolithically, against a clean concrete surface, free of laitance with surface intentionally roughened to an amplitude of 0.25 in.:

$$\begin{aligned} c &= 0.24 \text{ ksi} \\ \mu &= 1.0 \\ K_1 &= 0.25 \\ K_2 &= 1.0 \text{ ksi} \end{aligned}$$

- For normal-weight concrete placed against a clean concrete surface, free of laitance, with surface intentionally roughened to an amplitude of 0.25 in.:

$$\begin{aligned} c &= 0.24 \text{ ksi} \\ \mu &= 1.0 \\ K_1 &= 0.25 \\ K_2 &= 1.5 \text{ ksi} \end{aligned}$$

- For concrete placed against a clean concrete surface, free of laitance, but not intentionally roughened:

$$\begin{aligned} c &= 0.075 \text{ ksi} \\ \mu &= 0.6 \\ K_1 &= 0.2 \\ K_2 &= 0.8 \text{ ksi} \end{aligned}$$

- For concrete anchored to as-rolled structural steel by headed studs or by reinforcing bars where all steel in contact with concrete is clean and free of paint:

$$\begin{aligned} c &= 0.025 \text{ ksi} \\ \mu &= 0.7 \\ K_1 &= 0.2 \\ K_2 &= 0.8 \text{ ksi} \end{aligned}$$

For brackets, corbels, and ledges, the cohesion factor, c , shall be taken as 0.0.

5.8.4.4—Minimum Area of Interface Shear Reinforcement

Except as provided herein, the cross-sectional area of the interface shear reinforcement, A_{vf} , crossing the interface area, A_{cv} , shall satisfy:

$$A_{vf} \geq \frac{0.05A_{cv}}{f_y} \tag{5.8.4.4-1}$$

For a cast-in-place concrete slab on clean concrete girder surfaces free of laitance, the following provisions shall apply:

Available experimental data demonstrates that only one modification factor is necessary, when coupled with the resistance factors of Article 5.5.4.2, to accommodate both all-lightweight and sand-lightweight concrete. Note this deviates from earlier specifications that distinguished between all-lightweight and sand-lightweight concrete.

Due to the absence of existing data, the prescribed cohesion and friction factors for nonmonolithic lightweight concrete are accepted as conservative for application to monolithic lightweight concrete.

Tighter constraints have been adopted for roughened interfaces, other than cast-in-place slabs on roughened girders, even though available test data does not indicate more severe restrictions are necessary. This is to account for variability in the geometry, loading and lack of redundancy at other interfaces.

Since the effectiveness of cohesion and aggregate interlock along a vertical crack interface is unreliable the cohesion component in Eq. 5.8.4.1-3 is set to 0.0 for brackets, corbels, and ledges.

C5.8.4.4

For a girder/slab interface, the minimum area of interface shear reinforcement per foot of girder length is calculated by replacing A_{cv} in Eq. 5.8.4.4-1 with $12b_{vi}$.

Previous editions of these specifications and of the AASHTO Standard Specifications have required a minimum area of reinforcement based on the full

- The minimum interface shear reinforcement, A_{vs} , need not exceed the lesser of the amount determined using Eq. 5.8.4.4-1 and the amount needed to resist $1.33V_{ui}/\phi$ as determined using Eq. 5.8.4.1-3.
- The minimum reinforcement provisions specified herein shall be waived for girder/slab interfaces with surface roughened to an amplitude of 0.25 in. where the factored interface shear stress, v_{ui} of Eq. 5.8.4.2-1, is less than 0.210 ksi, and all vertical (transverse) shear reinforcement required by the provisions of Article 5.8.2.5 is extended across the interface and adequately anchored in the slab.

5.8.5—Principal Stresses in Webs of Segmental Concrete Bridges

The provisions specified herein shall apply to all types of segmental bridges with internal and/or external tendons.

The principal tensile stress resulting from the long-term residual axial stress and maximum shear and/or maximum shear combined with shear from torsion stress at the neutral axis of the critical web shall not exceed the tensile stress limit of Table 5.9.4.2.2-1 at the Service III limit state of Article 3.4.1 at all stages during the life of the structure, excluding those during construction. When investigating principal stresses during construction, the tensile stress limits of Table 5.14.2.3.3-1 shall apply.

The principal stress shall be determined using classical beam theory and the principles of Mohr's Circle. The width of the web for these calculations shall be measured perpendicular to the plane of the web.

Compressive stress due to vertical tendons provided in the web shall be considered in the calculation of the principal stress. The vertical force component of draped longitudinal tendons shall be considered as a reduction in the shear force due to the applied loads.

Local tensions produced in webs resulting from anchorage of tendons as discussed in Article 5.10.9.2 shall be included in the principal tension check.

Local transverse flexural stress due to out-of-plane flexure of the web itself at the critical section may be neglected in computing the principal tension in webs.

interface area; similar to Eq. 5.8.4.4-1, irrespective of the need to mobilize the strength of the full interface area to resist the applied factored interface shear. In 2006, the additional minimum area provisions, applicable only to girder/slab interfaces, were introduced. The intent of these provisions was to eliminate the need for additional interface shear reinforcement due simply to a beam with a wider top flange being utilized in place of a narrower flanged beam.

The additional provision establishes a rational upper bound for the area of interface shear reinforcement required based on the interface shear demand rather than the interface area as stipulated by Eq. 5.8.4.4-1. This treatment is analogous to minimum reinforcement provisions for flexural capacity where a minimum additional overstrength factor of 1.33 is required beyond the factored demand.

With respect to a girder/slab interface, the intent is that the portion of the reinforcement required to resist vertical shear which is extended into the slab also serves as interface shear reinforcement.

C5.8.5

This principal stress check is introduced to verify the adequacy of webs of segmental concrete bridges for longitudinal shear and torsion.

5.8.6—Shear and Torsion for Segmental Box Girder Bridges

5.8.6.1—General

Where it is reasonable to assume that plane sections remain plane after loading, the provisions presented herein shall be used for the design of segmental post-tensioned concrete box girder bridges for shear and torsion in lieu of the provisions of Article 5.8.3.

The applicable provisions of Articles 5.8.1, 5.8.2, 5.8.4, and 5.8.5 may apply, as modified by the provisions herein.

Discontinuity regions (where the plane sections assumption of flexural theory is not applicable) shall be designed using the provisions of Article 5.8.6.2 and the strut-and-tie model approach of Article 5.6.3. The provisions of Article 5.13.2 shall apply to special discontinuity regions such as deep beams, brackets and corbels, as appropriate.

The effects of any openings or ducts in members shall be considered. In determining the effective web or flange thickness, b_e , the diameters of ungrouted ducts or one-half the diameters of grouted ducts shall be subtracted from the web or flange thickness at the location of these ducts.

The values of $\sqrt{f'_c}$ used in any part of Article 5.8.6 shall not exceed 3.16.

The design yield strength of transverse shear or torsion reinforcement shall be in accordance with Article 5.8.2.8.

5.8.6.2—Loading

Design for shear and torsion shall be performed at the strength limit state load combinations as defined in Article 3.4.1.

The shear component of the primary effective longitudinal prestress force acting in the direction of the applied shear being examined, V_p , shall be added to the load effect, with a load factor of 1.0.

The secondary shear effects from prestressing shall be included in the PS load defined in Article 3.3.2.

The vertical component of inclined tendons shall only be considered to reduce the applied shear on the webs for tendons which are anchored or fully developed by anchorages, deviators, or internal ducts located in the top or bottom 1/3 of the webs.

The effects of factored torsional moments, T_u , shall be considered in the design when their magnitude exceeds the value specified in Article 5.8.6.3.

C5.8.6.1

For types of construction other than segmental box girders, the provisions of Article 5.8.3 may be applied in lieu of the provisions of Article 5.8.6.

Discontinuity regions where the plane sections assumption of flexural theory is not applicable include regions adjacent to abrupt changes in cross-sections, openings, dapped ends, regions where large concentrated loads, reactions, or post-tensioning forces are applied or deviated, diaphragms, deep beams, corbels or joints.

The effects of using concrete with $\sqrt{f'_c} > 3.16$ on the allowable stress limits is not well known.

C5.8.6.2

Design of prestressed concrete segmental bridges for shear and torsion is based on the strength limit state conditions because little information is available concerning actual shear stress distributions at the service limit state.

This load effect should only be added to the box girder analysis and not transferred into the substructure. Some designers prefer to add this primary prestress force shear component to the resistance side of the equation.

For members subjected to combined shear and torsion, the torsional moments produce shear forces in different elements of the structure that, depending on the direction of torsion, may add to or subtract from the shear force in the element due to vertical shear. Where it is required to consider the effects of torsional moments, the shear forces from torsion need to be added to those from the vertical shear when determining the design shear force acting on a specific element. The possibility

of the torsional moment reversing direction should be investigated.

In a statically indeterminate structure where significant reduction of torsional moment in a member can occur due to redistribution of internal forces upon cracking, the applied factored torsion moment at a section, T_u , may be reduced to ϕT_{cr} , provided that moments and forces in the member and in adjoining members are adjusted to account for the redistribution.

where:

- T_u = factored torsional moment (kip-in.)
 T_{cr} = torsional cracking moment calculated using Eq. 5.8.6.3-2 (kip-in.)
 ϕ = resistance factor for shear specified in Article 5.5.4.2

In lieu of a more refined analysis, the torsional loading from a slab may be assumed as linearly distributed along the member.

The effects of axial tension due to creep, shrinkage, and thermal effects in restrained members shall be considered wherever applicable.

The component of inclined flexural compression or tension, in the direction of the applied shear, in variable depth members shall be considered when determining the design factored shear force.

5.8.6.3—Regions Requiring Consideration of Torsional Effects

For normal weight concrete, torsional effects shall be investigated where:

$$T_u > 1/3 \phi T_{cr} \quad (5.8.6.3-1)$$

in which:

$$T_{cr} = 0.0632 K \sqrt{f'_c} 2 A_o b_e \quad (5.8.6.3-2)$$

$$K = \sqrt{1 + \frac{f_{pc}}{0.0632 \sqrt{f'_c}}} \leq 2.0 \quad (5.8.6.3-3)$$

where:

- T_u = factored torsional moment (kip-in.)
 T_{cr} = torsional cracking moment (kip-in.)
 K = stress variable K shall not be taken greater than 1.0 for any section where the stress in the extreme tension fiber, calculated on the basis of gross section properties, due to factored load and effective prestress force after losses exceeds $0.19\sqrt{f'_c}$ in tension.
 A_o = area enclosed by the shear flow path of a closed box section, including any holes therein (in.²)

- b_e = effective width of the shear flow path, but not exceeding the minimum thickness of the webs or flanges comprising the closed box section (in.). b_e shall be adjusted to account for the presence of ducts as specified in Article 5.8.6.1.
- p_c = the length of the outside perimeter of the concrete section (in.)
- f_{pc} = unfactored compressive stress in concrete after prestress losses have occurred either at the centroid of the cross-section resisting transient loads or at the junction of the web and flange where the centroid lies in the flange (ksi)
- ϕ = resistance factor for shear specified in Article 5.5.4.2

In lieu of a more refined analysis, b_e may be taken as A_{cp}/P_e , where A_{cp} is the area enclosed by the outside perimeter of the concrete cross-section and P_e is the outside perimeter of the concrete cross-section.

When calculating K for a section subject to factored axial force, N_u , f_{pc} shall be replaced with $f_{pc} - N_u/A_g$. N_u shall be taken as a positive value when the axial force is tensile and negative when it is compressive.

5.8.6.4—Torsional Reinforcement

C5.8.6.4

Where consideration of torsional effects is required by Article 5.8.6.3, torsion reinforcement shall be provided, as specified herein. This reinforcement shall be in addition to the reinforcement required to resist the factored shear, as specified in Article 5.8.6.5, flexure and axial forces that may act concurrently with the torsion.

The longitudinal and transverse reinforcement required for torsion shall satisfy:

$$T_u \leq \phi T_n \quad (5.8.6.4-1)$$

The nominal torsional resistance from transverse reinforcement shall be based on a truss model with 45-degree diagonals and shall be computed as:

$$T_n = \frac{2A_o A_v f_y}{s} \quad (5.8.6.4-2)$$

The minimum additional longitudinal reinforcement for torsion, A_ℓ , shall satisfy:

$$A_\ell \geq \frac{T_u p_h}{2\phi A_o f_y} \quad (5.8.6.4-3)$$

where:

- A_v = area of transverse shear reinforcement (in.²)
- A_ℓ = total area of longitudinal torsion reinforcement in the exterior web of the box girder (in.²)

In determining the required amount of longitudinal reinforcement, the beneficial effect of longitudinal prestressing is taken into account by considering it equivalent to an area of reinforcing steel with a yield force equal to the effective prestressing force.

- T_u = applied factored torsional moment (kip-in.)
 p_h = perimeter of the polygon defined by the centroids of the longitudinal chords of the space truss resisting torsion. p_h may be taken as the perimeter of the centerline of the outermost closed stirrups (in.)
 A_o = area enclosed by shear flow path, including area of holes, if any (in.²)
 f_y = yield strength of additional longitudinal reinforcement (ksi)
 ϕ = resistance factor for shear specified in Article 5.5.4.2

A_t shall be distributed around the perimeter of the closed stirrups in accordance with Article 5.8.6.6.

Subject to the minimum reinforcement requirements of Article 5.8.6.6, the area of additional longitudinal torsion reinforcement in the flexural compression zone may be reduced by an amount equal to:

$$\frac{M_u}{(0.9d_e f_y)} \quad (5.8.6.4-4)$$

where:

- M_u = the factored moment acting at that section concurrent with T_u (kip-in.)
 d_e = effective depth from extreme compression fiber to the centroid of the tensile force in the tensile reinforcement (in.)
 f_y = specified minimum yield strength of reinforcing bars (ksi)

5.8.6.5—Nominal Shear Resistance

In lieu of the provisions of Article 5.8.3, the provisions herein shall be used to determine the nominal shear resistance of post-tensioned concrete box girders in regions where it is reasonable to assume that plane sections remain plane after loading.

Transverse reinforcement shall be provided when $V_u > 0.5\phi V_c$, where V_c is computed by Eq. 5.8.6.5-4.

The nominal shear resistance, V_n , shall be determined as the lesser of:

$$V_n = V_c + V_s \quad (5.8.6.5-1)$$

$$V_n = 0.379 \sqrt{f'_c} b_v d_v \quad (5.8.6.5-2)$$

and, where the effects of torsion are required to be considered by Article 5.8.6.2, the cross-sectional dimensions shall be such that:

$$V_c = 0.0632 K \sqrt{f'_c} b_v d_v \quad (5.8.6.5-3)$$

in which:

C5.8.6.5

The expression for V_c has been checked against a wide range of test data and has been found to be a conservative expression.

$$V_s = \frac{A_v f_y d_v}{s} \quad (5.8.6.5-4)$$

Eq. 5.8.6.5-4 is based on an assumed 45-degree truss model.

$$\left(\frac{V_u}{b_v d_v} \right) + \left(\frac{T_u}{2 A_o b_e} \right) \leq 0.474 \sqrt{f'_c} \quad (5.8.6.5-5)$$

Eq. 5.8.6.5-5 is only used to establish appropriate concrete section dimensions.

where:

- b_v = effective web width taken as the minimum web width within the depth d_v as determined in Article 5.8.6.1 (in.)
- d_v = $0.8h$ or the distance from the extreme compression fiber to the centroid of the prestressing reinforcement, whichever is greater (in.)
- s = spacing of stirrups (in.)
- K = stress variable computed in accordance with Article 5.8.6.3.
- A_v = area of shear reinforcement within a distance s (in.²)
- V_u = factored design shear including any normal component from the primary prestressing force (kip)
- T_u = applied factored torsional moment (kip-in.)
- A_o = area enclosed by shear flow path, including area of holes, if any (in.²)
- b_e = the effective thickness of the shear flow path of the elements making up the space truss model resisting torsion calculated in accordance with Article 5.8.6.3 (in.)
- ϕ = resistance factor for shear specified in Article 5.5.4.2

The factored nominal shear resistance, ϕV_n , shall be greater than or equal to V_u .

The applied factored shear, V_u , in regions near supports may be computed at a distance $h/2$ from the support when the support reaction, in the direction of the applied shear, introduces compression into the support region of the member and no concentrated load occurs within a distance, h , from the face of the support.

5.8.6.6—Reinforcement Details

In addition to the provisions herein, the provisions of Article 5.10 and 5.11 shall also apply to segmental post-tensioned box girders, as applicable.

At any place on the cross-section where the axial tension due to torsion and bending exceeds the axial compression due to prestressing and bending, either supplementary tendons to counter the tension or local longitudinal reinforcement, which is continuous across the joints between segments, shall be required.

Where supplementary tendons are added, they shall be located to provide compression around the perimeter of the closed box section.

Where local longitudinal reinforcement is added, the bars shall be distributed around the perimeter formed by the closed stirrups. Perimeter bar spacing shall not exceed 18.0 in. At least one longitudinal bar shall be placed in each corner of the stirrups. The minimum diameter of the corner bars shall be 1/24 of the stirrup spacing but no less than that of a #5 bar.

The spacing of the transverse reinforcement shall not exceed the maximum permitted spacing, s_{max} , determined as:

- If $v_u < 0.19\sqrt{f'_c}$, then:

$$s_{max} = 0.8d \leq 36.0 \text{ in.} \quad (5.8.6.6-1)$$

- If $v_u \geq 0.19\sqrt{f'_c}$, then:

$$s_{max} = 0.4d \leq 18.0 \text{ in.} \quad (5.8.6.6-2)$$

where:

- v_u = the shear stress calculated in accordance with Eq. 5.8.6.5-5 (ksi)
- d_v = effective shear depth as defined in Article 5.8.6.5 (in.)

Transverse reinforcement for shear and torsion shall be provided for a distance at least $h/2$ beyond the point they are theoretically required.

Interface shear transfer reinforcement shall be provided as specified in Article 5.8.4.

5.9—PRESTRESSING

5.9.1—General Design Considerations

5.9.1.1—General

The provisions herein specified shall apply to structural concrete members reinforced with any combination of prestressing tendons and conventional reinforcing bars acting together to resist common force effects. Prestressed structural components shall be designed for both initial and final prestressing forces. They shall satisfy the requirements at service, fatigue, strength, and extreme event limit states, as specified in Article 5.5, and in accordance with the assumptions provided in Articles 5.6, 5.7, and 5.8.

Unstressed prestressing tendons or reinforcing bars may be used in combination with stressed tendons, provided it is shown that performance of the structure satisfies all limit states and the requirements of Articles 5.4 and 5.6.

Compressive stress limits, specified in Article 5.9.4, shall be used with any applicable service load combination in Table 3.4.1-1, except Service Load Combination III, which shall not apply to the investigation of compression.

Tensile stress limits, specified in Article 5.9.4, shall be used with any applicable service load combination in

C5.9.1.1

The background material in this Article is based on previous editions of the Standard Specifications and on ACI 343, ACI 318, and the *Ontario Highway Bridge Design Code*.

Prestressing tendons of high-strength steel bars or strands are generally used but other materials satisfying desired strength, stiffness, and ductility requirements could also be used, provided that they meet the intent of Article 5.4.1.

A unified theory of concrete structures recognizes conventional reinforced concrete and fully prestressed concrete as limiting cases encompassing levels of precompression ranging from none to that necessary to satisfy the Service III limit state specified in Table 5.9.4.2.2-1. Prior to 2011, these Specifications identified intermediate cases between these two extremes as partially prestressed concrete including:

- A concrete member designed with a combination of prestressed and nonprestressed reinforcement that act together to resist common force effects at the strength limit state and

Table 3.4.1-1. Service Load Combination III shall apply when investigating tension under live load.

- A prestressed concrete member designed to crack in tension under the combination of effective prestress and full service load at the Service III limit state while satisfying the requirements for the fatigue limit states.

5.9.1.2—Specified Concrete Strengths

The specified strengths, f'_c and f'_{ci} , shall be identified in the contract documents for each component. Stress limits relating to specified strengths shall be as specified in Article 5.9.4.

Concrete strength at transfer shall be adequate for the requirements of the anchorages or for transfer through bond as well as for camber or deflection requirements.

5.9.1.3—Buckling

Buckling of a member between points where concrete and tendons are in contact, buckling during handling and erection, and buckling of thin webs and flanges shall be investigated.

5.9.1.4—Section Properties

For section properties prior to bonding of post-tensioning tendons, effects of loss of area due to open ducts shall be considered.

For both pretensioned or post-tensioned members after bonding of tendons, section properties may be based on either the gross or transformed section.

5.9.1.5—Crack Control

Where cracking is permitted under service loads, crack width, fatigue of reinforcement, and corrosion considerations shall be investigated in accordance with the provisions of Articles 5.5, 5.6, and 5.7.

5.9.1.6—Tendons with Angle Points or Curves

The provisions of Article 5.4.6 for the curvature of ducts shall apply.

The provisions of Article 5.10.4 shall apply to the investigation of stress concentrations due to changes in the direction of prestressing tendons.

For tendons in draped ducts that are not nominally straight, consideration shall be given to the difference between the center of gravity of the tendon and the center of gravity of the duct when determining eccentricity.

The provisions of Article 5.8.1.5 for the webs of curved post-tensioned box girder bridges shall apply.

C5.9.1.4

Bonding means that the grout in the duct has attained its specified strength.

C5.9.1.6

Vertically draped strand tendons should be assumed to be at the bottom of the duct in negative moment areas and at the top of the duct in positive moment areas. The location of the tendon center of gravity, with respect to the centerline of the duct, is shown for negative moment in Figure C5.9.1.6-1.

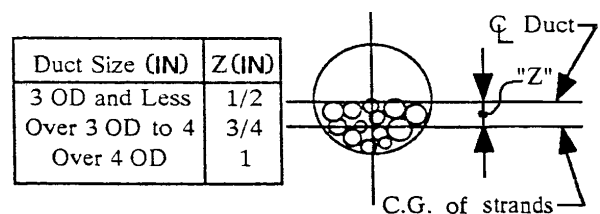

Figure C5.9.1.6-1—Location of Tendon in Duct

5.9.2—Stresses Due to Imposed Deformation

The effects on adjoining elements of the structure of elastic and inelastic deformations due to prestressing shall be investigated. The restraining forces produced in the adjoining structural elements may be reduced due to the effects of creep.

In monolithic frames, force effects in columns and piers resulting from prestressing the superstructure may be based on the initial elastic shortening.

For conventional monolithic frames, any increase in column moments due to long-term creep shortening of the prestressed superstructure is considered to be offset by the concurrent relaxation of deformation moments in the columns due to creep in the column concrete.

The reduction of restraining forces in other members of a structure that are caused by the prestress in a member may be taken as:

- For suddenly imposed deformations

$$F' = F(1 - e^{-\Psi(t, t_i)}), \text{ or} \quad (5.9.2-1)$$

- For slowly imposed deformations

$$F' = F(1 - e^{-\Psi(t, t_i)}) / \Psi(t, t_i) \quad (5.9.2-2)$$

where:

- F = force effect determined using the modulus of elasticity of the concrete at the time loading is applied (kip)
- F' = reduced force effect (kip)
- $\Psi(t, t_i)$ = creep coefficient at time t for loading applied at time t_i as specified in Article 5.4.2.3.2
- e = base of Napierian logarithms

5.9.3—Stress Limitations for Prestressing Tendons

The tendon stress due to prestress or at the service limit state shall not exceed the values:

- Specified in Table 5.9.3-1, or
- Recommended by the manufacturer of the tendons or anchorages.

The tendon stress at the strength and extreme event limit states shall not exceed the tensile strength limit specified in Table 5.4.4.1-1.

C5.9.2

Additional information is contained in Leonhardt (1964).

C5.9.3

For post-tensioning, the short-term allowable of $0.90f_{py}$ may be allowed for short periods of time prior to seating to offset seating and friction losses, provided that the other values in Table 5.9.3-1 are not exceeded.

Table 5.9.3-1—Stress Limits for Prestressing Tendons

Condition	Tendon Type		
	Stress-Relieved Strand and Plain High-Strength Bars	Low Relaxation Strand	Deformed High-Strength Bars
Pretensioning			
Immediately prior to transfer (f_{pbt})	$0.70f_{pu}$	$0.75f_{pu}$	—
At service limit state after all losses (f_{pe})	$0.80f_{py}$	$0.80f_{py}$	$0.80f_{py}$
Post-Tensioning			
Prior to seating—short-term f_{pbt} may be allowed	$0.90f_{py}$	$0.90f_{py}$	$0.90f_{py}$
At anchorages and couplers immediately after anchor set	$0.70f_{pu}$	$0.70f_{pu}$	$0.70f_{pu}$
Elsewhere along length of member away from anchorages and couplers immediately after anchor set	$0.70f_{pu}$	$0.74f_{pu}$	$0.70f_{pu}$
At service limit state after losses (f_{pe})	$0.80f_{py}$	$0.80f_{py}$	$0.80f_{py}$

5.9.4—Stress Limits for Concrete

5.9.4.1—For Temporary Stresses before Losses—Fully Prestressed Components

5.9.4.1.1—Compression Stresses

The compressive stress limit for pretensioned and post-tensioned concrete components, including segmentally constructed bridges, shall be $0.60 f'_{ci}$ (ksi).

5.9.4.1.2—Tension Stresses

The limits in Table 5.9.4.1.2-1 shall apply for tensile stresses.

C5.9.4.1.2

Where bonded reinforcement is provided to allow use of the increased tensile limiting stress in areas with bonded reinforcement, the tensile force must be computed. The first step in computing the tensile force, T , is to determine the depth of the tensile zone using the extreme fiber stresses at the location being considered, $f_{ci\ top}$ and $f_{ci\ bot}$. An area is then defined over which the average tensile stress is assumed to act. The tensile force is computed as the product of the average tensile stress and the computed area, as illustrated below. The required area of reinforcement, A_s , is computed by dividing the tensile force by the permitted stress in the reinforcement.

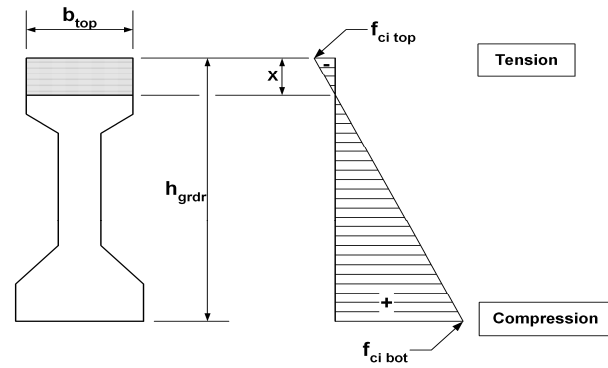

$$T = \frac{f_{ci\ top}}{2} b_{top} x$$

$$A_s = \frac{T}{f_s}$$

where $f_s = 0.5 f_y \leq 30$ ksi

Figure C5.9.4.1.2-1—Calculation of Tensile Force and Required Area of Reinforcement

Table 5.9.4.1.2-1—Temporary Tensile Stress Limits in Prestressed Concrete before Losses, Fully Prestressed Components

Bridge Type	Location	Stress Limit
Other Than Segmentally Constructed Bridges	<ul style="list-style-type: none"> In precompressed tensile zone without bonded reinforcement 	N/A
	<ul style="list-style-type: none"> In areas other than the precompressed tensile zone and without bonded reinforcement 	$0.0948\sqrt{f'_{ci}} \leq 0.2$ (ksi)
	<ul style="list-style-type: none"> In areas with bonded reinforcement (reinforcing bars or prestressing steel) sufficient to resist the tensile force in the concrete computed assuming an uncracked section, where reinforcement is proportioned using a stress of $0.5f_y$, not to exceed 30 ksi. 	$0.24\sqrt{f'_{ci}}$ (ksi)
	<ul style="list-style-type: none"> For handling stresses in prestressed piles 	$0.158\sqrt{f'_{ci}}$ (ksi)
Segmentally Constructed Bridges	Longitudinal Stresses through Joints in the Precompressed Tensile Zone <ul style="list-style-type: none"> Joints with minimum bonded auxiliary reinforcement through the joints, which is sufficient to carry the calculated tensile force at a stress of $0.5f_y$; with internal tendons or external tendons Joints without the minimum bonded auxiliary reinforcement through the joints 	$0.0948\sqrt{f'_{ci}}$ maximum tension (ksi) No tension
	Transverse Stresses through Joints <ul style="list-style-type: none"> For any type of joint 	$0.0948\sqrt{f'_{ci}}$ (ksi)
	Stresses in Other Areas <ul style="list-style-type: none"> For areas without bonded nonprestressed reinforcement In areas with bonded reinforcement (reinforcing bars or prestressing steel) sufficient to resist the tensile force in the concrete computed assuming an uncracked section, where reinforcement is proportioned using a stress of $0.5f_y$, not to exceed 30 ksi. 	No tension $0.19\sqrt{f'_{ci}}$ (ksi)
	Principal Tensile Stress at Neutral Axis in Web <ul style="list-style-type: none"> All types of segmental concrete bridges with internal and/or external tendons, unless the Owner imposes other criteria for critical structures 	$0.110\sqrt{f'_{ci}}$ (ksi)

5.9.4.2—For Stresses at Service Limit State after Losses—Fully Prestressed Components

5.9.4.2.1—Compression Stresses

C5.9.4.2.1

Compression shall be investigated using the Service Limit State Load Combination I specified in Table 3.4.1-1. The limits in Table 5.9.4.2.1-1 shall apply.

The reduction factor, ϕ_w , shall be taken to be equal to 1.0 when the web and flange slenderness ratios, calculated according to Article 5.7.4.7.1, are not greater than 15. When either the web or flange slenderness ratio is greater than 15, the reduction factor, ϕ_w , shall be calculated according to Article 5.7.4.7.2.

Unlike solid rectangular beams that were used in the development of concrete design codes, the unconfined concrete of the compression sides of box girders are expected to creep to failure at a stress far lower than the nominal strength of the concrete. This behavior is similar to the behavior of the concrete in thin-walled columns. The reduction factor, ϕ_w , was originally developed to account for the reduction in the usable strain of concrete in thin-walled columns at the strength limit state. The use of ϕ_w to reduce the stress limit in box girders at the service limit state is not theoretically correct. However, due to the lack of information about the behavior of the concrete at the service limit state, the use of ϕ_w provides a rational approach to account for the behavior of thin components.

The application of Article 5.7.4.7.2 to flanged, strutted, and variable thickness elements requires some judgment. Consideration of appropriate lengths of wall-type element is illustrated in Figure C5.9.4.2.1-1. For constant thickness lengths, the wall thickness associated with that length should be used. For variable thickness lengths, e.g., L_4 , an average thickness could be used. For multilength components, such as the top flange, the highest ratio should be used. The beneficial effect of support by struts should be considered. There are no effective length factors shown. The free edge of the cantilever overhang is assumed to be supported by the parapet in Figure C5.9.4.2.1-1.

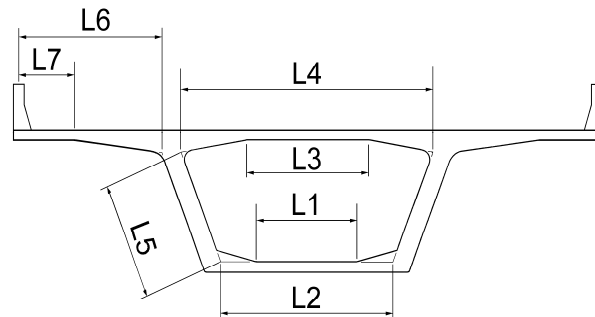

Figure C5.9.4.2.1-1—Suggested Choices for Wall Lengths to be Considered

Table 5.9.4.2.1-1—Compressive Stress Limits in Prestressed Concrete at Service Limit State after Losses, Fully Prestressed Components

Location	Stress Limit
<ul style="list-style-type: none"> In other than segmentally constructed bridges due to the sum of effective prestress and permanent loads 	$0.45f'_c$ (ksi)
<ul style="list-style-type: none"> In segmentally constructed bridges due to the sum of effective prestress and permanent loads 	$0.45f'_c$ (ksi)
<ul style="list-style-type: none"> Due to the sum of effective prestress, permanent loads, and transient loads as well as during shipping and handling 	$0.60 \phi_w f'_c$ (ksi)

5.9.4.2.2—Tension Stresses

For longitudinal service load combinations that involve traffic loading tension stresses in members with bonded or unbonded prestressing tendons should be investigated using load combination Service III specified in Table 3.4.1-1. Load combination Service I should be investigated for load combinations that involve traffic loadings in transverse analyses of box girder bridges.

The limits in Table 5.9.4.2.2-1 shall apply.

C5.9.4.2.2

Severe corrosive conditions include exposure to deicing salt, water, or airborne sea salt and airborne chemicals in heavy industrial areas.

See Figure C5.9.4.1.2-1 for calculation of required area of bonded reinforcement.

Table 5.9.4.2.2-1—Tensile Stress Limits in Prestressed Concrete at Service Limit State after Losses, Fully Prestressed Components

Bridge Type	Location	Stress Limit
Other Than Segmentally Constructed Bridges	Tension in the Precompressed Tensile Zone Bridges, Assuming Uncracked Sections	
	<ul style="list-style-type: none"> For components with bonded prestressing tendons or reinforcement that are subjected to not worse than moderate corrosion conditions 	$0.19\sqrt{f'_c}$ (ksi)
	<ul style="list-style-type: none"> For components with bonded prestressing tendons or reinforcement that are subjected to severe corrosive conditions For components with unbonded prestressing tendons 	$0.0948\sqrt{f'_c}$ (ksi) No tension
Segmentally Constructed Bridges	Longitudinal Stresses through Joints in the Precompressed Tensile Zone	
	<ul style="list-style-type: none"> Joints with minimum bonded auxiliary reinforcement through the joints sufficient to carry the calculated longitudinal tensile force at a stress of $0.5 f_y$; internal tendons or external tendons 	$0.0948\sqrt{f'_c}$ (ksi)
	<ul style="list-style-type: none"> Joints without the minimum bonded auxiliary reinforcement through joints 	No tension
	Transverse Stresses through Joints	
	<ul style="list-style-type: none"> Tension in the transverse direction in precompressed tensile zone 	$0.0948\sqrt{f'_c}$ (ksi)
	Stresses in Other Areas	
	<ul style="list-style-type: none"> For areas without bonded reinforcement In areas with bonded reinforcement sufficient to resist the tensile force in the concrete computed assuming an uncracked section, where reinforcement is proportioned using a stress of $0.5 f_y$, not to exceed 30 ksi 	No tension $0.19\sqrt{f'_c}$ (ksi)
	Principal Tensile Stress at Neutral Axis in Web	
	<ul style="list-style-type: none"> All types of segmental concrete bridges with internal and/or external tendons, unless the Owner imposes other criteria for critical structures. 	$0.110\sqrt{f'_c}$ (ksi)

5.9.5—Loss of Prestress

5.9.5.1—Total Loss of Prestress

Values of prestress losses specified herein shall be applicable to normal weight concrete only and for specified concrete strengths up to 15.0 ksi, unless stated otherwise.

In lieu of more detailed analysis, prestress losses in members constructed and prestressed in a single stage, relative to the stress immediately before transfer, may be taken as:

- In pretensioned members:

$$\Delta f_{pT} = \Delta f_{pES} + \Delta f_{pLT} \quad (5.9.5.1-1)$$

- In post-tensioned members:

$$\Delta f_{pT} = \Delta f_{pF} + \Delta f_{pA} + \Delta f_{pES} + \Delta f_{pLT} \quad (5.9.5.1-2)$$

where:

Δf_{pT}	=	total loss (ksi)
Δf_{pF}	=	loss due to friction (ksi)
Δf_{pA}	=	loss due to anchorage set (ksi)
Δf_{pES}	=	sum of all losses or gains due to elastic shortening or extension at the time of application of prestress and/or external loads (ksi)
Δf_{pLT}	=	losses due to long-term shrinkage and creep of concrete, and relaxation of the steel (ksi)

C5.9.5.1

For segmental construction, lightweight concrete construction, multi-stage prestressing, and bridges where more exact evaluation of prestress losses is desired, calculations for loss of prestress should be made in accordance with a time-step method supported by proven research data. See references cited in Article C5.4.2.3.2.

Data from control tests on the materials to be used, the methods of curing, ambient service conditions, and pertinent structural details for the construction should be considered.

Accurate estimate of total prestress loss requires recognition that the time-dependent losses resulting from creep, shrinkage, and relaxation are also interdependent. However, undue refinement is seldom warranted or even possible at the design stage because many of the component factors are either unknown or beyond the control of the Designer.

Losses due to anchorage set, friction, and elastic shortening are instantaneous, whereas losses due to creep, shrinkage, and relaxation are time-dependent.

This Article has been revised on the basis of new analytical investigations. The presence of a substantial amount of nonprestressed reinforcement, such as in partially prestressed concrete, influences stress redistribution along the section due to creep of concrete with time, and generally leads to smaller loss of prestressing steel pretension and larger loss of concrete precompression.

The loss across stressing hardware and anchorage devices has been measured from two to six percent (Roberts, 1993) of the force indicated by the ram pressure times the calibrated ram area. The loss varies depending on the ram and the anchor. An initial design value of three percent is recommended.

The extension of the provisions to 15.0 ksi was based on Tadros (2003), which only included normal weight concrete. Consequently, the extension to 15.0 ksi is only valid for members made with normal weight concrete.

5.9.5.2—Instantaneous Losses

5.9.5.2.1—Anchorage Set

The magnitude of the anchorage set shall be the greater of that required to control the stress in the prestressing steel at transfer or that recommended by the manufacturer of the anchorage. The magnitude of the set assumed for the design and used to calculate set loss shall be shown in the contract documents and verified during construction.

C5.9.5.2.1

Anchorage set loss is caused by the movement of the tendon prior to seating of the wedges or the anchorage gripping device. The magnitude of the minimum set depends on the prestressing system used. This loss occurs prior to transfer and causes most of the difference between jacking stress and stress at transfer. A common value for anchor set is 0.375 in., although values as low as 0.0625 in. are more appropriate for some anchorage devices, such as those for bar tendons.

For wedge-type strand anchors, the set may vary between 0.125 in. and 0.375 in., depending on the type of equipment used. For short tendons, a small anchorage seating value is desirable, and equipment with power wedge seating should be used. For long tendons, the effect of anchorage set on tendon forces is insignificant, and power seating is not necessary. The 0.25-in. anchorage set value, often assumed in elongation computations, is adequate but only approximate.

Due to friction, the loss due to anchorage set may affect only part of the prestressed member.

Losses due to elastic shortening may also be calculated in accordance with Article 5.9.5.2.3 or other published guidelines (PCI 1975; Zia et. al. 1979). Losses due to elastic shortening for external tendons may be calculated in the same manner as for internal tendons.

5.9.5.2.2—Friction

5.9.5.2.2a—Pretensioned Construction

For draped prestressing tendons, losses that may occur at the hold-down devices should be considered.

5.9.5.2.2b—Post-Tensioned Construction

Losses due to friction between the internal prestressing tendons and the duct wall may be taken as:

$$\Delta f_{pF} = f_{pj} \left(1 - e^{-(Kx + \mu \alpha)} \right) \quad (5.9.5.2.2b-1)$$

Losses due to friction between the external tendon across a single deviator pipe may be taken as:

$$\Delta f_{pF} = f_{pj} \left(1 - e^{-\mu(\alpha+0.04)} \right) \quad (5.9.5.2.2b-2)$$

where:

- f_{pj} = stress in the prestressing steel at jacking (ksi)
- x = length of a prestressing tendon from the jacking end to any point under consideration (ft)
- K = wobble friction coefficient (per ft of tendon)
- μ = coefficient of friction
- α = sum of the absolute values of angular change of prestressing steel path from jacking end, or from the nearest jacking end if tensioning is done equally at both ends, to the point under investigation (rad.)
- e = base of Napierian logarithms

Values of K and μ should be based on experimental data for the materials specified and shall be shown in the contract documents. In the absence of such data, a value within the ranges of K and μ as specified in Table 5.9.5.2.2b-1 may be used.

C5.9.5.2.2b

Where large discrepancies occur between measured and calculated tendon elongations, in-place friction tests are required.

The 0.04 radians in Eq. 5.9.5.2.2b-2 represents an inadvertent angle change. This angle change may vary depending on job-specific tolerances on deviator pipe placement and need not be applied in cases where the deviation angle is strictly controlled or precisely known, as in the case of continuous ducts passing through separate longitudinal bell-shaped holes at deviators. The inadvertent angle change need not be considered for calculation of losses due to wedge seating movement.

For slender members, the value of x may be taken as the projection of the tendon on the longitudinal axis of the member. A friction coefficient of 0.25 is appropriate for 12 strand tendons. A lower coefficient may be used for larger tendon and duct sizes. See also Article C5.14.2.3.7 for further discussion of friction and wobble coefficients.

For tendons confined to a vertical plane, α shall be taken as the sum of the absolute values of angular changes over length x .

For tendons curved in three dimensions, the total tridimensional angular change α shall be obtained by vectorially adding the total vertical angular change, α_v , and the total horizontal angular change, α_h .

α_v and α_h may be taken as the sum of absolute values of angular changes over length, x , of the projected tendon profile in the vertical and horizontal planes, respectively.

The scalar sum of α_v and α_h may be used as a first approximation of α .

When the developed elevation and plan of the tendons are parabolic or circular, the α can be computed from:

$$\alpha = \sqrt{\alpha_v^2 + \alpha_h^2} \tag{C5.9.5.2.2b-1}$$

When the developed elevation and the plan of the tendon are generalized curves, the tendon may be split into small intervals, and the above formula can be applied to each interval so that:

$$\alpha = \Sigma \Delta \alpha = \Sigma \sqrt{\Delta \alpha_v^2 + \Delta \alpha_h^2} \tag{C5.9.5.2.2b-2}$$

As an approximation, the tendon may be replaced by a series of chords connecting nodal points. The angular changes, $\Delta \alpha_v$ and $\Delta \alpha_h$, of each chord may be obtained from its slope in the developed elevation and in plan.

Field tests conducted on the external tendons of a segmental viaduct in San Antonio, Texas, indicate that the loss of prestress at deviators is higher than the usual friction coefficient ($\mu = 0.25$) would estimate.

This additional loss appears to be due, in part, to the tolerances allowed in the placement of the deviator pipes. Small misalignments of the pipes can result in significantly increased angle changes of the tendons at the deviation points. The addition of an inadvertent angle change of 0.04 radians to the theoretical angle change accounts for this effect based on typical deviator length of 3.0 ft and placement tolerance of $\pm 3/8$ in. The 0.04 value is to be added to the theoretical value at each deviator. The value may vary with tolerances on pipe placement.

The measurements also indicated that the friction across the deviators was higher during the stressing operations than during the seating operations.

See Podolny (1986) for a general development of friction loss theory for bridges with inclined webs and for horizontally curved bridges.

Table 5.9.5.2.2b-1—Friction Coefficients for Post-Tensioning Tendons

Type of Steel	Type of Duct	K	μ
Wire or strand	Rigid and semirigid galvanized metal sheathing	0.0002	0.15–0.25
	Polyethylene	0.0002	0.23
	Rigid steel pipe deviators for external tendons	0.0002	0.25
High-strength bars	Galvanized metal sheathing	0.0002	0.30

5.9.5.2.3—Elastic Shortening

5.9.5.2.3a—Pretensioned Members

C5.9.5.2.3a

The loss due to elastic shortening in pretensioned members shall be taken as:

$$\Delta f_{pES} = \frac{E_p}{E_{ct}} f_{cgp} \quad (5.9.5.2.3a-1)$$

where:

f_{cgp} = the concrete stress at the center of gravity of prestressing tendons due to the prestressing force immediately after transfer and the self-weight of the member at the section of maximum moment (ksi).

E_p = modulus of elasticity of prestressing steel (ksi)

E_{ct} = modulus of elasticity of concrete at transfer or time of load application (ksi)

The total elastic loss or gain may be taken as the sum of the effects of prestress and applied loads.

Changes in prestressing steel stress due to the elastic deformations of the section occur at all stages of loading. Historically, it has been conservative to account for this effect implicitly in the calculation of elastic shortening and creep losses considering only the prestress force present after transfer.

The change in prestressing steel stress due to the elastic deformations of the section may be determined for any load applied. The resulting change may be a loss, at transfer, or a gain, at time of superimposed load application. Where a more detailed analysis is desired, Eq. 5.9.5.2.3a-1 may be used at each section along the beam, for the various loading conditions.

In calculating f_{cgp} , using gross (or net) cross-section properties, it may be necessary to perform a separate calculation for each different elastic deformation to be included. For the combined effects of initial prestress and member weight, an initial estimate of prestress after transfer is used. The prestress may be assumed to be 90 percent of the initial prestress before transfer and the analysis iterated until acceptable accuracy is achieved. To avoid iteration altogether, Eq. C5.9.5.2.3a-1 may be used for the initial section. If the inclusion of an elastic gain due to the application of the deck weight is desired, the change in prestress force can be directly calculated. The same is true for all other elastic gains with appropriate consideration for composite sections.

When calculating concrete stresses using transformed section properties, the effects of losses and gains due to elastic deformations are implicitly accounted for and Δf_{pES} should not be included in the prestressing force applied to the transformed section at transfer. Nevertheless, the effective prestress in the strands can be determined by subtracting losses (elastic and time-dependent) from the jacking stress. In other words, when using transformed section properties, the prestressing strand and the concrete are treated together as a composite section in which both the concrete and the prestressing strand are equally strained in compression by a prestressing force conceived as a fictitious external load applied at the level of the strands. To determine the effective stress in the prestressing strands (neglecting time-dependent losses for simplicity) the sum of the Δf_{pES} values considered must be included. In contrast, analysis with gross (or net) section properties involves using the effective stress in the strands at any given stage of loading to determine the prestress force and resulting concrete stresses.

The loss due to elastic shortening in pretensioned members may be determined by the following alternative equation:

$$\Delta f_{pES} = \frac{A_{ps} f_{pbt} (I_g + e_m^2 A_g) - e_m M_g A_g}{A_{ps} (I_g + e_m^2 A_g) + \frac{A_g I_g E_{ci}}{E_p}} \quad (C5.9.5.2.3a-1)$$

where:

- A_{ps} = area of prestressing steel (in.²)
- A_g = gross area of section (in.²)
- E_{ci} = modulus of elasticity of concrete at transfer (ksi)
- E_p = modulus of elasticity of prestressing tendons (ksi)
- e_m = average prestressing steel eccentricity at midspan (in.)
- f_{pbt} = stress in prestressing steel immediately prior to transfer (ksi)
- I_g = moment of inertia of the gross concrete section (in.⁴)
- M_g = midspan moment due to member self-weight (kip-in.)

5.9.5.2.3b—Post-Tensioned Members

The loss due to elastic shortening in post-tensioned members, other than slab systems, may be taken as:

$$\Delta f_{pES} = \frac{N-1}{2N} \frac{E_p}{E_{ci}} f_{cgp} \quad (5.9.5.2.3b-1)$$

where:

- N = number of identical prestressing tendons
- f_{cgp} = sum of concrete stresses at the center of gravity of prestressing tendons due to the prestressing force after jacking and the self-weight of the member at the sections of maximum moment (ksi)

f_{cgp} values may be calculated using a steel stress reduced below the initial value by a margin dependent on elastic shortening, relaxation, and friction effects.

For post-tensioned structures with bonded tendons, f_{cgp} may be taken at the center section of the span or, for continuous construction, at the section of maximum moment.

For post-tensioned structures with unbonded tendons, the f_{cgp} value may be calculated as the stress at the center of gravity of the prestressing steel averaged along the length of the member.

For slab systems, the value of Δf_{pES} may be taken as 25 percent of that obtained from Eq. 5.9.5.2.3b-1.

C5.9.5.2.3b

The loss due to elastic shortening in post-tensioned members, other than slab systems, may be determined by the following alternative equation:

$$\Delta f_{pES} = \frac{N-1}{2N} \frac{A_{ps} f_{pbt} (I_g + e_m^2 A_g) - e_m M_g A_g}{A_{ps} (I_g + e_m^2 A_g) + \frac{A_g I_g E_{ci}}{E_p}} \quad (C5.9.5.2.3b-1)$$

where:

- A_{ps} = area of prestressing steel (in.²)
- A_g = gross area of section (in.²)
- E_{ci} = modulus of elasticity of concrete at transfer (ksi)
- E_p = modulus of elasticity of prestressing tendons (ksi)
- e_m = average eccentricity at midspan (in.)
- f_{pbt} = stress in prestressing steel immediately prior to transfer as specified in Table 5.9.3-1 (ksi)
- I_g = moment of inertia of the gross concrete section (in.⁴)
- M_g = midspan moment due to member self-weight (kip-in.)
- N = number of identical prestressing tendons
- f_{pj} = stress in the prestressing steel at jacking (ksi)

For post-tensioned structures with bonded tendons, Δf_{pES} may be calculated at the center section of the span or, for continuous construction, at the section of maximum moment.

For post-tensioned structures with unbonded tendons, Δf_{pES} can be calculated using the eccentricity of the prestressing steel averaged along the length of the member.

For slab systems, the value of Δf_{pES} may be taken as 25 percent of that obtained from Eq. C5.9.5.2.3b-1.

For post-tensioned construction, Δf_{pES} losses can be further reduced below those implied by Eq. 5.9.5.2.3b-1 with proper tensioning procedures such as stage stressing and retensioning.

If tendons with two different numbers of strand per tendon are used, N may be calculated as:

$$N = N_1 + N_2 \frac{A_{sp2}}{A_{sp1}} \quad (C5.9.5.2.3b-2)$$

where:

- N_1 = number of tendons in the larger group
- N_2 = number of tendons in the smaller group
- A_{sp1} = cross-sectional area of a tendon in the larger group (in.²)
- A_{sp2} = cross-sectional area of a tendon in the smaller group (in.²)

5.9.5.2.3c—Combined Pretensioning and Post-Tensioning

In applying the provisions of Articles 5.9.5.2.3a and 5.9.5.2.3b to components with combined pretensioning and post-tensioning, and where post-tensioning is not applied in identical increments, the effects of subsequent post-tensioning on the elastic shortening of previously stressed prestressing tendons shall be considered.

5.9.5.3—Approximate Estimate of Time-Dependent Losses

For standard precast, pretensioned members subject to normal loading and environmental conditions, where:

- members are made from normal-weight concrete,
- the concrete is either steam- or moist-cured,
- prestressing is by bars or strands with normal and low relaxation properties, and
- average exposure conditions and temperatures characterize the site,

the long-term prestress loss, Δf_{pLT} , due to creep of concrete, shrinkage of concrete, and relaxation of steel shall be estimated using the following formula:

$$\Delta f_{pLT} = 10.0 \frac{f_{pi} A_{ps}}{A_g} \gamma_h \gamma_{st} + 12.0 \gamma_h \gamma_{st} + \Delta f_{pR} \quad (5.9.5.3-1)$$

in which:

C5.9.5.2.3c

See Castrodale and White (2004) for information on computing the effect of subsequent post-tensioning on the elastic shortening of previously stressed prestressing tendons.

C5.9.5.3

The losses or gains due to elastic deformations at the time of transfer or load application should be added to the time-dependent losses to determine total losses. However, these elastic losses (or gains) must be taken equal to zero if transformed section properties are used in stress analysis.

The approximate estimates of time-dependent prestress losses given in Eq. 5.9.5.3-1 are intended for sections with composite decks only. The losses in Eq. 5.9.5.3-1 were derived as approximations of the terms in the refined method for a wide range of standard precast prestressed concrete I-beams and inverted tee beams. The members were assumed to be fully utilized, i.e., level of prestressing is such that concrete tensile stress at full service loads is near the maximum limit. It is further assumed in the development of the approximate method that live load moments produce about one-third of the total load moments, which is reasonable for I-beam and inverted tee composite construction and conservative for noncomposite boxes and voided slabs. They were calibrated with full-scale test results and with the results of the refined method,

$$\gamma_h = 1.7 - 0.01H \quad (5.9.5.3-2)$$

$$\gamma_{st} = \frac{5}{(1 + f'_{ci})} \quad (5.9.5.3-3)$$

where:

f_{pi} = prestressing steel stress immediately prior to transfer (ksi)

H = the average annual ambient relative humidity (%)

γ_h = correction factor for relative humidity of the ambient air

γ_{st} = correction factor for specified concrete strength at time of prestress transfer to the concrete member

Δf_{pR} = an estimate of relaxation loss taken as 2.4 ksi for low relaxation strand, 10.0 ksi for stress relieved strand, and in accordance with manufacturers recommendation for other types of strand (ksi)

For girders other than those made with composite slabs, the time-dependent prestress losses resulting from creep and shrinkage of concrete and relaxation of steel shall be determined using the refined method of Article 5.9.5.4.

For segmental concrete bridges, lump sum losses may be used only for preliminary design purposes.

For members of unusual dimensions, level of prestressing, construction staging, or concrete constituent materials, the refined method of Article 5.9.5.4 or computer time-step methods shall be used.

5.9.5.4—Refined Estimates of Time-Dependent Losses

5.9.5.4.1—General

For nonsegmental prestressed members, more accurate values of creep-, shrinkage-, and relaxation-related losses, than those specified in Article 5.9.5.3 may be determined in accordance with the provisions of this Article. For precast pretensioned girders without a composite topping and for precast or cast-in-place nonsegmental post-tensioned girders, the provisions of Articles 5.9.5.4.4 and 5.9.5.4.5, respectively, shall be considered before applying the provisions of this Article.

For segmental construction and post-tensioned spliced precast girders, other than during preliminary design, prestress losses shall be determined by the time-step method and the provisions of Article 5.9.5, including consideration of the time-dependent construction stages and schedule shown in the contract documents. For components with combined pretensioning and post-tensioning, and where post-

and found to give conservative results (Al-Omaishi, 2001; Tadros, 2003). The approximate method should not be used for members of uncommon shapes, i.e., having V/S ratios much different from 3.5 in., level of prestressing, or construction staging. The first term in Eq. 5.9.5.3-1 corresponds to creep losses, the second term to shrinkage losses, and the third to relaxation losses.

The commentary to Article 5.9.5.4.2 also gives an alternative relaxation loss prediction method.

C5.9.5.4.1

See Castrodale and White (2004) for information on computing the interaction of creep effects for prestressing applied at different times.

Estimates of losses due to each time-dependent source, such as creep, shrinkage, or relaxation, can lead to a better estimate of total losses compared with the values obtained using Article 5.9.5.3. The individual losses are based on research published in Tadros (2003), which aimed at extending applicability of the provisions of these Specifications to high-strength concrete. The new approach additionally accounts for interaction between the precast and the cast-in-place concrete components of a composite member and for variability of creep and shrinkage properties of concrete by linking the loss formulas to the creep and shrinkage prediction formulae of Article 5.4.2.3.

tensioning is applied in more than one stage, the effects of subsequent prestressing on the creep loss for previous prestressing shall be considered.

The change in prestressing steel stress due to time-dependent loss, Δf_{pLT} , shall be determined as follows:

$$\Delta f_{pLT} = (\Delta f_{pSR} + \Delta f_{pCR} + \Delta f_{pR1})_{id} + (\Delta f_{pSD} + \Delta f_{pCD} + \Delta f_{pR2} - \Delta f_{pSS})_{df} \quad (5.9.5.4.1-1)$$

where:

Δf_{pSR} = prestress loss due to shrinkage of girder concrete between transfer and deck placement (ksi)

Δf_{pCR} = prestress loss due to creep of girder concrete between transfer and deck placement (ksi)

Δf_{pR1} = prestress loss due to relaxation of prestressing strands between time of transfer and deck placement (ksi)

Δf_{pR2} = prestress loss due to relaxation of prestressing strands in composite section between time of deck placement and final time (ksi)

Δf_{pSD} = prestress loss due to shrinkage of girder concrete between time of deck placement and final time (ksi)

Δf_{pCD} = prestress loss due to creep of girder concrete between time of deck placement and final time (ksi)

Δf_{pSS} = prestress gain due to shrinkage of deck in composite section (ksi)

$(\Delta f_{pSR} + \Delta f_{pCR} + \Delta f_{pR1})_{id}$
= sum of time-dependent prestress losses between transfer and deck placement (ksi)

$(\Delta f_{pSD} + \Delta f_{pCD} + \Delta f_{pR2} - \Delta f_{pSS})_{df}$
= sum of time-dependent prestress losses after deck placement (ksi)

For concrete containing lightweight aggregates, very hard aggregates, or unusual chemical admixtures, the estimated material properties used in this Article and Article 5.4.2.3 may be inaccurate. Actual test results should be used for their estimation.

For segmental construction, for all considerations other than preliminary design, prestress losses shall be determined as specified in Article 5.9.5, including consideration of the time-dependent construction method and schedule shown in the contract documents.

5.9.5.4.2—Losses: Time of Transfer to Time of Deck Placement

5.9.5.4.2a—Shrinkage of Girder Concrete

The prestress loss due to shrinkage of girder concrete between time of transfer and deck placement, Δf_{pSR} , shall be determined as:

$$\Delta f_{pSR} = \epsilon_{bid} E_p K_{id} \quad (5.9.5.4.2a-1)$$

in which:

$$K_{id} = \frac{1}{1 + \frac{E_p A_{ps}}{E_{ci} A_g} \left(1 + \frac{A_g e_{pg}^2}{I_g} \right) [1 + 0.7 \Psi_b(t_f, t_i)]} \quad (5.9.5.4.2a-2)$$

where:

- ϵ_{bid} = concrete shrinkage strain of girder between the time of transfer and deck placement per Eq. 5.4.2.3.3-1
- K_{id} = transformed section coefficient that accounts for time-dependent interaction between concrete and bonded steel in the section being considered for time period between transfer and deck placement
- e_{pg} = eccentricity of prestressing force with respect to centroid of girder (in.); positive in common construction where it is below girder centroid
- $\Psi_b(t_f, t_i)$ = girder creep coefficient at final time due to loading introduced at transfer per Eq. 5.4.2.3.2-1
- t_f = final age (days)
- t_i = age at transfer (days)

5.9.5.4.2b—Creep of Girder Concrete

The prestress loss due to creep of girder concrete between time of transfer and deck placement, Δf_{pCR} , shall be determined as:

$$\Delta f_{pCR} = \frac{E_p}{E_{ci}} f_{cgp} \Psi_b(t_d, t_i) K_{id} \quad (5.9.5.4.2b-1)$$

where:

- $\Psi_b(t_d, t_i)$ = girder creep coefficient at time of deck placement due to loading introduced at transfer per Eq. 5.4.2.3.2-1
- t_d = age at deck placement (days)

5.9.5.4.2c—Relaxation of Prestressing Strands

The prestress loss due to relaxation of prestressing strands between time of transfer and deck placement, Δf_{pR1} , shall be determined as:

$$\Delta f_{pR1} = \frac{f_{pr}}{K_L} \left(\frac{f_{pr}}{f_{py}} - 0.55 \right) \quad (5.9.5.4.2c-1)$$

C5.9.5.4.2c

Eqs. 5.9.5.4.2c-1 and 5.9.5.4.3c-1 are given for relaxation losses and are appropriate for normal temperature ranges only. Relaxation losses increase with increasing temperatures.

A more accurate equation for prediction of relaxation loss between transfer and deck placement is given in Tadros et al. (2003):

where:

f_{pt} = stress in prestressing strands immediately after transfer, taken not less than $0.55f_{py}$ in Eq. 5.9.5.4.2c-1

K_L = 30 for low relaxation strands and 7 for other prestressing steel, unless more accurate manufacturer's data are available

The relaxation loss, Δf_{pR1} , may be assumed equal to 1.2 ksi for low-relaxation strands.

$$\Delta f_{pR1} = \left[\frac{f_{pt}}{K'_L} \log(24t) \left(\frac{f_{pt}}{f_{py}} - 0.55 \right) \right] \left[1 - \frac{3(\Delta f_{pSR} + \Delta f_{pCR})}{f_{pt}} \right] K_{id} \quad (C5.9.5.4.2c-1)$$

where the K'_L is a factor accounting for type of steel, equal to 45 for low relaxation steel and 10 for stress relieved steel, t is time in days between strand tensioning and deck placement. The term in the first square brackets is the intrinsic relaxation without accounting for strand shortening due to creep and shrinkage of concrete. The second term in square brackets accounts for relaxation reduction due to creep and shrinkage of concrete. The factor K_{id} accounts for the restraint of the concrete member caused by bonded reinforcement. It is the same factor used for the creep and shrinkage components of the prestress loss. The equation given in Article 5.9.5.4.2c is an approximation of the above formula with the following typical values assumed:

$$t_i = 0.75 \text{ day}$$

$$t = 120 \text{ days}$$

$$\left[1 - \frac{3(\Delta f_{pSR} + \Delta f_{pCR})}{f_{pt}} \right] = 0.67$$

$$K_{id} = 0.8$$

5.9.5.4.3—Losses: Time of Deck Placement to Final Time

5.9.5.4.3a—Shrinkage of Girder Concrete

The prestress loss due to shrinkage of girder concrete between time of deck placement and final time, Δf_{pSD} , shall be determined as:

$$\Delta f_{pSD} = \epsilon_{bdf} E_p K_{df} \quad (5.9.5.4.3a-1)$$

in which:

$$K_{df} = \frac{1}{1 + \frac{E_p}{E_{ct}} \frac{A_{ps}}{A_c} \left(1 + \frac{A_c e^2}{I_c} \right) [1 + 0.7 \Psi_b(t_f, t_i)]} \quad (5.9.5.4.3a-2)$$

where:

ϵ_{bdf} = shrinkage strain of girder between time of deck placement and final time per Eq. 5.4.2.3.3-1

K_{df} = transformed section coefficient that accounts for time-dependent interaction between concrete and bonded steel in the section being considered for time period between deck placement and final time

- e_{pc} = eccentricity of prestressing force with respect to centroid of composite section (in.), positive in typical construction where prestressing force is below centroid of section
- A_c = area of section calculated using the gross composite concrete section properties of the girder and the deck and the deck-to-girder modular ratio (in.²)
- I_c = moment of inertia of section calculated using the gross composite concrete section properties of the girder and the deck and the deck-to-girder modular ratio at service (in.⁴)

5.9.5.4.3b—Creep of Girder Concrete

The prestress (loss is positive, gain is negative) due to creep of girder concrete between time of deck placement and final time, Δf_{pCD} , shall be determined as:

$$\Delta f_{pCD} = \frac{E_p}{E_{ci}} f_{cgp} [\Psi_b(t_f, t_i) - \Psi_b(t_d, t_i)] K_{df} + \frac{E_p}{E_c} \Delta f_{cd} \Psi_b(t_f, t_d) K_{df} \tag{5.9.5.4.3b-1}$$

where:

- Δf_{cd} = change in concrete stress at centroid of prestressing strands due to long-term losses between transfer and deck placement, combined with deck weight and superimposed loads (ksi)
- $\Psi_b(t_f, t_d)$ = girder creep coefficient at final time due to loading at deck placement per Eq. 5.4.2.3.2-1

5.9.5.4.3c—Relaxation of Prestressing Strands

C5.9.5.4.3.c

The prestress loss due to relaxation of prestressing strands in composite section between time of deck placement and final time, Δf_{pR2} , shall be determined as:

Research indicates that about one-half of the losses due to relaxation occur before deck placement; therefore, the losses after deck placement are equal to the prior losses.

$$\Delta f_{pR2} = \Delta f_{pR1} \tag{5.9.5.4.3c-1}$$

5.9.5.4.3d—Shrinkage of Deck Concrete

The prestress gain due to shrinkage of deck composite section, Δf_{pSS} , shall be determined as:

$$\Delta f_{pSS} = \frac{E_p}{E_c} \Delta f_{cdf} K_{df} [1 + 0.7 \Psi_b(t_f, t_d)] \tag{5.9.5.4.3d-1}$$

in which:

$$\Delta f_{cdf} = \frac{\epsilon_{ddf} A_d E_{cd}}{[1 + 0.7\Psi_d(t_f, t_d)]} \left(\frac{1}{A_c} - \frac{e_{pc} e_d}{I_c} \right) \quad (5.9.5.4.3d-2)$$

where:

- Δf_{cdf} = change in concrete stress at centroid of prestressing strands due to shrinkage of deck concrete (ksi)
- ϵ_{ddf} = shrinkage strain of deck concrete between placement and final time per Eq. 5.4.2.3.3-1
- A_d = area of deck concrete (in.²)
- E_{cd} = modulus of elasticity of deck concrete (ksi)
- e_d = eccentricity of deck with respect to the gross composite section, positive in typical construction where deck is above girder (in.)
- $\Psi_b(t_f, t_d)$ = creep coefficient of deck concrete at final time due to loading introduced shortly after deck placement (i.e. overlays, barriers, etc.) per Eq. 5.4.2.3.2-1

5.9.5.4.4—Precast Pretensioned Girders without Composite Topping

The equations in Article 5.9.5.4.2 and Article 5.9.5.4.3 are applicable to girders with noncomposite deck or topping, or with no topping. The values for time of “deck placement” in Article 5.9.5.4.2 may be taken as values at time of noncomposite deck placement or values at time of installation of precast members without topping. Time of “deck placement” in Article 5.9.5.4.3 may be taken as time of noncomposite deck placement or values at time of installation of precast members without topping. Area of “deck” for these applications shall be taken as zero.

5.9.5.4.5—Post-Tensioned Nonsegmental Girders

Long-term prestress losses for post-tensioned members after tendons have been grouted may be calculated using the provisions of Articles 5.9.5.4.1 through 5.9.5.4.4. In Eq. 5.9.5.4.1-1, the value of the term $(\Delta f_{pSR} + \Delta f_{pCR} + \Delta f_{pR1})_{id}$ shall be taken as zero.

5.9.5.5—Losses for Deflection Calculations

For camber and deflection calculations of prestressed nonsegmental members made of normal weight concrete with a strength in excess of 3.5 ksi at the time of prestress, f_{cgp} and Δf_{cdp} may be computed as the stress at the center of gravity of prestressing steel averaged along the length of the member.

5.10—DETAILS OF REINFORCEMENT

5.10.1—Concrete Cover

Minimum concrete cover shall be as specified in Article 5.12.3.

5.10.2—Hooks and Bends

5.10.2.1—Standard Hooks

For the purpose of these Specifications, the term “standard hook” shall mean one of the following:

- For longitudinal reinforcement:
 - (a) 180-degree bend, plus a $4.0d_b$ extension, but not less than 2.5 in. at the free end of the bar, or
 - (b) 90-degree bend, plus a $12.0d_b$ extension at the free end of the bar.
- For transverse reinforcement:
 - (a) No. 5 bar and smaller—90-degree bend, plus a $6.0d_b$ extension at the free end of the bar,
 - (b) No. 6, No. 7 and No. 8 bars—90-degree bend, plus a $12.0d_b$ extension at the free end of the bar; and
 - (c) No. 8 bar and smaller—135-degree bend, plus a $6.0 d_b$ extension at the free end of the bar.

where:

d_b = nominal diameter of reinforcing bar (in.)

5.10.2.2—Seismic Hooks

Seismic hooks shall consist of a 135-degree bend, plus an extension of not less than the larger of $6.0d_b$ or 3.0 in. Seismic hooks shall be used for transverse reinforcement in regions of expected plastic hinges. Such hooks and their required locations shall be detailed in the contract documents.

5.10.2.3—Minimum Bend Diameters

The diameter of a bar bend, measured on the inside of the bar, shall not be less than that specified in Table 5.10.2.3-1.

C5.10.2.1

These requirements are consistent with the requirements of ACI 318 and CRSI's *Manual of Standard Practice*.

Table 5.10.2.3-1—Minimum Diameters of Bend

Bar Size and Use	Minimum Diameter
No. 3 through No. 5—General	$6.0d_b$
No. 3 through No. 5—Stirrups and Ties	$4.0d_b$
No. 6 through No. 8—General	$6.0d_b$
No. 9, No. 10, and No. 11	$8.0d_b$
No. 14 and No. 18	$10.0d_b$

The inside diameter of bend for stirrups and ties in plain or deformed welded wire fabric shall not be less than $4.0d_b$ for deformed wire larger than D6 and $2.0d_b$ for all other wire sizes. Bends with inside diameters of less than $8.0d_b$ shall not be located less than $4.0d_b$ from the nearest welded intersection.

5.10.3—Spacing of Reinforcement

5.10.3.1 Minimum Spacing of Reinforcing Bars

5.10.3.1.1—Cast-in-Place Concrete

For cast-in-place concrete, the clear distance between parallel bars in a layer shall not be less than:

- 1.5 times the nominal diameter of the bars,
- 1.5 times the maximum size of the coarse aggregate, or
- 1.5 in.

5.10.3.1.2—Precast Concrete

For precast concrete manufactured under plant control conditions, the clear distance between parallel bars in a layer shall not be less than:

- The nominal diameter of the bars,
- 1.33 times the maximum size of the coarse aggregate, or
- 1.0 in.

5.10.3.1.3—Multilayers

Except in decks where parallel reinforcing is placed in two or more layers, with clear distance between layers not exceeding 6.0 in., the bars in the upper layers shall be placed directly above those in the bottom layer, and the clear distance between layers shall not be less than 1.0 in. or the nominal diameter of the bars.

5.10.3.1.4—Splices

The clear distance limitations between bars that are specified in Articles 5.10.3.1.1 and 5.10.3.1.2 shall also apply to the clear distance between a contact lap splice and adjacent splices or bars.

5.10.3.1.5—Bundled Bars

The number of parallel reinforcing bars bundled in contact to act as a unit shall not exceed four in any one bundle, except that in flexural members, the number of bars larger than No. 11 shall not exceed two in any one bundle.

Bundled bars shall be enclosed within stirrups or ties.

Individual bars in a bundle, cut off within the span of a member, shall be terminated at different points with at least a 40-bar diameter stagger. Where spacing limitations are based on bar size, a unit of bundled bars shall be treated as a single bar of a diameter derived from the equivalent total area.

5.10.3.2—Maximum Spacing of Reinforcing Bars

Unless otherwise specified, the spacing of the reinforcement in walls and slabs shall not exceed 1.5 times the thickness of the member or 18.0 in. The maximum spacing of spirals, ties, and temperature shrinkage reinforcement shall be as specified in Articles 5.10.6, 5.10.7, and 5.10.8.

5.10.3.3—Minimum Spacing of Prestressing Tendons and Ducts

5.10.3.3.1—Pretensioning Strand

The distance between pretensioning strands, including shielded ones, at each end of a member within the transfer length, as specified in Article 5.11.4.1, shall not be less than a clear distance taken as 1.33 times the maximum size of the aggregate nor less than the center-to-center distances specified in Table 5.10.3.3.1-1.

Table 5.10.3.3.1-1—Center-to-Center Spacings

Strand Size (in.)	Spacing (in.)
0.6 0.5625 Special 0.5625	2.000
0.5000 0.4375 0.50 Special	1.750
0.3750	1.500

C5.10.3.1.5

Bundled bars should be tied, wired, or otherwise fastened together to ensure that they remain in their relative position, regardless of their inclination.

C5.10.3.3.1

The requirement to maintain the clear spacing within the transfer zone is to ensure the strands are separated sufficiently to properly transfer their prestressing force to the surrounding concrete and to reduce the stress concentration around the strands at the ends of pretensioned components at release.

Some jurisdictions limit the clear distance between pretensioning strands to not less than twice the nominal size of aggregate to facilitate placing and compaction of concrete.

If justified by performance tests of full-scale prototypes of the design, the clear distance between strands at the end of a member may be decreased.

The minimum clear distance between groups of bundled strands shall not be less than 1.33 times the maximum size of the aggregate or 1.0 in.

Pretensioning strands in a member may be bundled to touch one another in an essentially vertical plane at and between hold-down locations. Strands bundled in any manner, other than a vertical plane, shall be limited to four strands per bundle.

5.10.3.3.2—Post-Tensioning Ducts—Girders Straight in Plan

Unless otherwise specified herein, the clear distance between straight post-tensioning ducts shall not be less than 1.5 in. or 1.33 times the maximum size of the coarse aggregate. For precast segmental construction when post-tensioning tendons extend through an epoxy joint between components, the clear spacing between post-tensioning ducts shall not be less than the greater of the duct internal diameter or 4.0 in.

Ducts may be bundled together in groups not exceeding three, provided that the spacing, as specified between individual ducts, is maintained between each duct in the zone within 3.0 ft of anchorages.

For groups of bundled ducts in construction other than segmental, the minimum clear horizontal distance between adjacent bundles shall not be less than 4.0 in. When groups of ducts are located in two or more horizontal planes, a bundle shall contain no more than two ducts in the same horizontal plane.

The minimum vertical clear distance between bundles shall not be less than 1.5 in. or 1.33 times the maximum size of coarse aggregate.

For precast construction, the minimum clear horizontal distance between groups of ducts may be reduced to 3.0 in.

5.10.3.3.3—Post-Tensioning Ducts—Girders Curved in Plan

The minimum clear distance between curved ducts shall be as required for tendon confinement as specified in Article 5.10.4.3. The spacing for curved ducts shall not be less than that required for straight ducts.

5.10.3.4—Maximum Spacing of Prestressing Tendons and Ducts in Slabs

Pretensioning strands for precast slabs shall be spaced symmetrically and uniformly and shall not be farther apart than 1.5 times the total composite slab thickness or 18.0 in.

Post-tensioning tendons for slabs shall not be farther apart, center-to-center, than 4.0 times the total composite minimum thickness of the slab.

C5.10.3.3.2

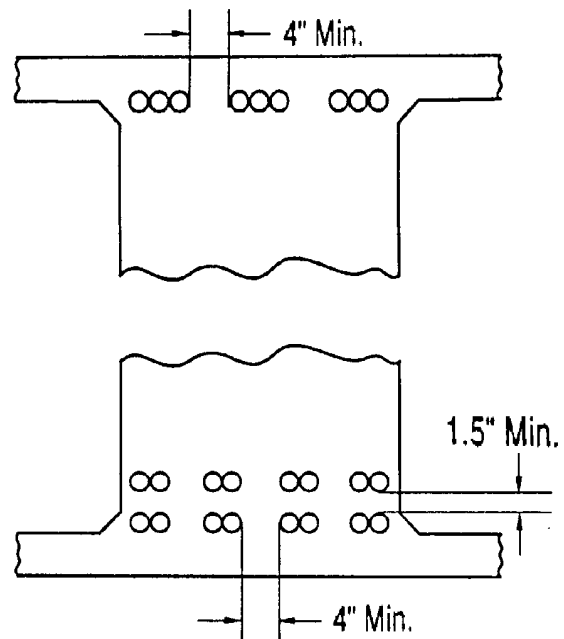

Figure C5.10.3.3.2-1—Examples of Acceptable Arrangements for Ducts Not Curved in the Horizontal Plan

C5.10.3.4

The 4.0 times depth of slab requirement for the maximum spacing of transverse post-tensioning ducts in deck slabs is new and reflects common practice. The composite thickness refers to slabs with bonded overlays.

5.10.3.5—Couplers in Post-Tensioning Tendons

The contract documents shall specify that not more than 50 percent of the longitudinal post-tensioning tendons be coupled at one section and that the spacing between adjacent coupler locations be not closer than the segment length or twice the segment depth. The void areas around couplers shall be deducted from the gross section area and moment of inertia when computing stresses at the time post-tensioning force is applied.

5.10.4—Tendon Confinement**5.10.4.1—General**

Tendons shall be located within the reinforcing steel stirrups in webs, and, where applicable, between layers of transverse reinforcing steel in flanges and slabs. For ducts in the bottom flanges of variable depth segments, nominal confinement reinforcing shall be provided around the duct at each segment face. The reinforcement shall not be less than two rows of No. 4 hairpin bars at both sides of each duct with vertical dimension equal to the slab thickness, less top and bottom cover dimensions.

The effects of grouting pressure in the ducts shall be considered.

5.10.4.2—Wobble Effect in Slabs

For the purpose of this Article, ducts spaced closer than 12.0 in. center-to-center in either direction shall be considered as closely spaced.

Where closely spaced transverse or longitudinal ducts are located in the flanges, and no provisions to minimize wobble of ducts are included in the contract documents, the top and bottom reinforcement mats should be tied together with No. 4 hairpin bars. The spacing between the hairpin bars shall not exceed 18.0 in. or 1.5 times the slab thickness in each direction.

5.10.4.3—Effects of Curved Tendons

Reinforcement shall be used to confine curved tendons if required by Article 5.8.1.5. The reinforcement shall be proportioned to ensure that the steel stress at service limit state does not exceed $0.6f_y$, and the assumed value of f_y shall not exceed 60.0 ksi. Unless a strut-and-tie analysis is done and indicates otherwise, Spacing of the confinement reinforcement shall not exceed either 3.0 times the outside diameter of the duct or 24.0 in.

Tendons shall not be bundled in groups greater than three when girders are curved in horizontal plane.

C5.10.3.5

European experience indicates that the prestressing force decreases locally in the region of a coupler. This is believed to result, in part, from increased creep caused by high compressive stresses in the reduced concrete section due to coupling of tendons. Cracking has not been observed in bridges where the number of tendons coupled at a section has been limited to 50 percent of the total number of tendons.

C5.10.4.1

This Article is based primarily on the recommendation from Breen and Kashima (1991).

C5.10.4.2

The hairpin bars are provided to prevent slab delamination along the plane of the post-tensioning ducts.

C5.10.4.3

Curved tendons induce deviation forces that are radial to the tendon in the plane of tendon curvature. Curved tendons with multiple strands or wires also induce out-of-plane forces that are perpendicular to the plane of tendon curvature.

Resistance to in-plane forces in curved girders may be provided by increasing the concrete cover over the duct, by adding confinement tie reinforcement or by a combination thereof.

It is not the purpose of this Article to encourage the use of curved tendons around re-entrant corners or voids. Where possible, this type of detail should be avoided.

5.10.4.3.1—Design for In-Plane Force Effects

5.10.4.3.1a—In-Plane Force Effects

In-plane deviation force effects due to the change in direction of tendons shall be taken as:

$$F_{u-in} = \frac{P_u}{R} \quad (5.10.4.3.1a-1)$$

where:

- F_{u-in} = the in-plane deviation force effect per unit length of tendon (kips/ft)
 P_u = the tendon force factored as specified in Article 3.4.3 (kip)
 R = the radius of curvature of the tendon at the considered location (ft)

The maximum deviation force shall be determined on the basis that all the tendons, including provisional tendons, are stressed. The provisions of Article 5.10.9 shall apply to design for in-plane force effects due to tendons curved at the tendon anchorage.

C5.10.4.3.1a

In-plane forces occur, for example, in anchorage blisters or curved webs, as shown in Figures C5.10.4.3.1a-1 and C5.10.4.3.1a-2. Without adequate reinforcement, the tendon deviation forces may rip through the concrete cover on the inside of the tendon curve, or unbalanced compressive forces may push off the concrete on the outside of the curve. Small radial tensile stresses may be resisted by concrete in tension.

The load factor of 1.2 taken from Article 3.4.3 and applied to the maximum tendon jacking force results in a design load of about 96 percent of the nominal ultimate strength of the tendon. This number compares well with the maximum attainable jacking force, which is limited by the anchor efficiency factor.

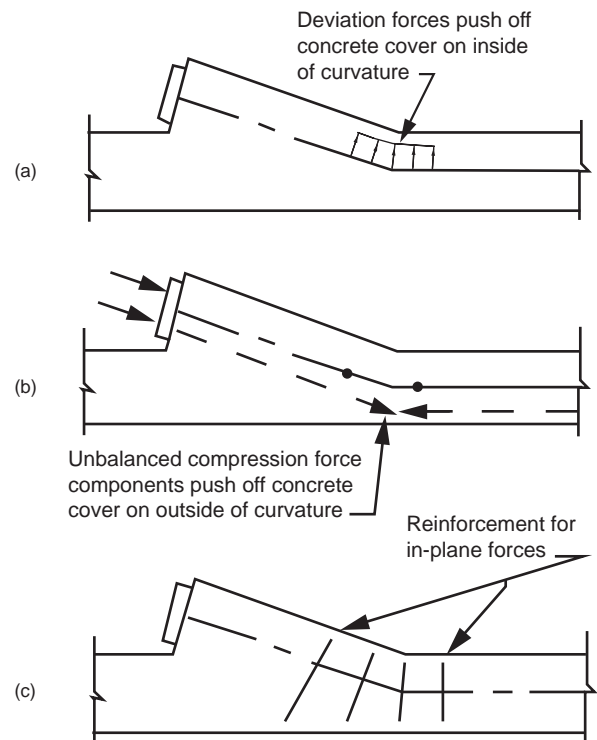

Figure C5.10.4.3.1a-1—In-Plane Forces in a Soffit Blister

The radial component from the longitudinal web stress in the concrete due to the compression in the cylindrical web must be subtracted.

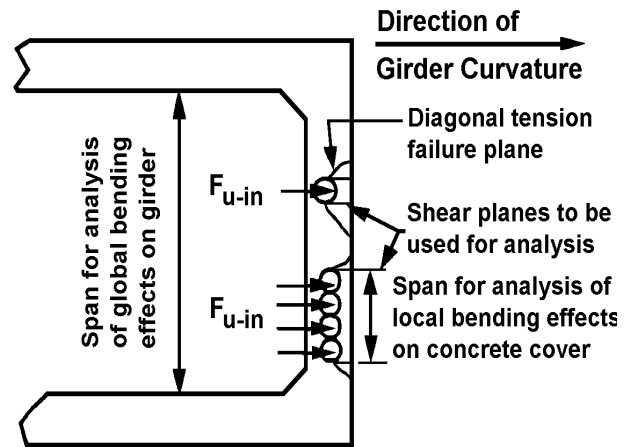

Figure C5.10.4.3.1a-2—In-Plane Force Effects in Curved Girders Due to Horizontally Curved Tendons

5.10.4.3.1b—Shear Resistance to Pull-out

The shear resistance per unit length of the concrete cover against pull-out by deviation forces, V_r , shall be taken as:

$$V_r = \phi V_n \tag{5.10.4.3.1b-1}$$

in which:

$$V_n = 0.15d_{eff}\sqrt{f'_{ci}} \quad V_n = 0.15d_{eff}\sqrt{f'_{ci}} \tag{5.10.4.3.1b-2}$$

where:

- V_n = nominal shear resistance of two shear planes per unit length (kips/in.)
- ϕ = resistance factor for shear, 0.75
- d_{eff} = one-half the effective length of the failure plane in shear and tension for a curved element (in.)

For single duct stack or for $s_{duct} < d_{duct}$, d_{eff} , shown in Detail (a) in Figure 5.10.4.3.1b-1, shall be taken as:

$$d_{eff} = d_c + \frac{d_{duct}}{4} \tag{5.10.4.3.1b-3}$$

For $s_{duct} \geq d_{duct}$, d_{eff} shall be taken as the lesser of the following based on Paths 1 and 2 shown in Detail (b) in Figure 5.10.4.3.1b-1:

$$d_{eff} = t_w - \frac{d_{duct}}{2} \tag{5.10.4.3.1b-4}$$

$$d_{eff} = d_c + \frac{d_{duct}}{4} + \frac{\sum s_{duct}}{2} \tag{5.10.4.3.1b-5}$$

where:

s_{duct} = clear distance between tendon ducts in vertical direction (in.)

C5.10.4.3.1b

The two shear planes for which Eq. 5.10.4.3.1b-3 gives V_n are as indicated in Figure 5.10.4.3.1b-1 for single and multiple tendons.

Where a staggered or side-by-side group of ducts is located side by side in a single web, all possible shear and tension failure planes should be considered in determining d_{eff} .

A generic stirrup and duct tie detail is shown in Figure C5.10.4.3.1b-1. Small diameter reinforcing bars should be used for better development of these bars. There have been no reported web failures when this detail has been used.

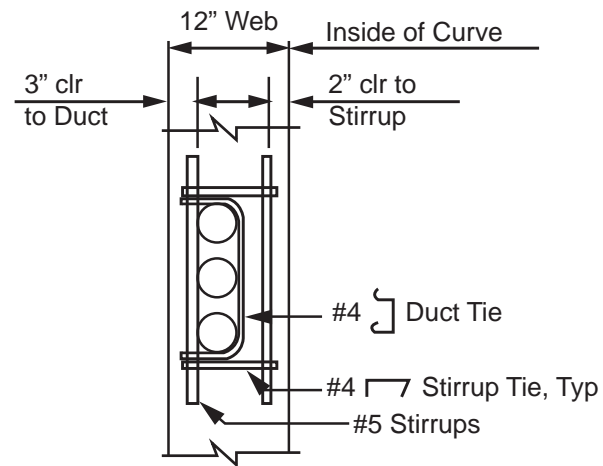

Figure C5.10.4.3.1b-1—Typical Stirrup and Duct Tie Detail

d_{duct} = outside diameter of prestress duct (in.)
 d_c = cover on duct (in.)
 t_w = web thickness (in.)

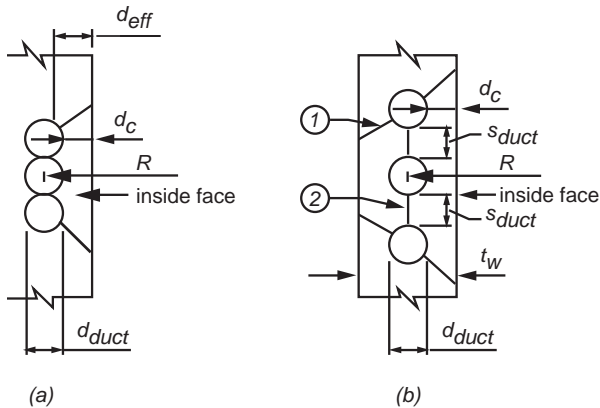

Figure 5.10.4.3.1b-1—Definition of d_{eff}

If the factored in-plane deviation force exceeds the factored shear resistance of the concrete cover, as specified in Eq. 5.10.4.3.1b-2, fully anchored stirrup and duct ties hooked around the outermost stirrup legs to resist the in-plane deviation forces shall be provided in the form of either nonprestressed or prestressed reinforcement.

5.10.4.3.1c—Cracking of Cover Concrete

When the clear distance between ducts oriented in a vertical column is less than 1.5 in., the ducts shall be considered stacked. Resistance to cracking shall be investigated at the ends and at midheight of the unreinforced cover concrete.

The applied local moment per unit length at the ends of the cover shall be taken as:

$$M_{end} = \frac{\left(\frac{\sum F_{u-in}}{h_{ds}}\right) h_{ds}^2}{12} \quad (5.10.4.3.1c-1)$$

And the applied local moment per unit length at the midheight of the cover shall be taken as:

$$M_{mid} = \frac{\left(\frac{\sum F_{u-in}}{h_{ds}}\right) h_{ds}^2}{24} \quad (5.10.4.3.1c-2)$$

where:

h_{ds} = the height of the duct stack as shown in Figure C5.10.4.3.1b-1

Tensile stresses in the unreinforced concrete cover resulting from Eqs. 5.10.4.3.1c-1 and 5.10.4.3.1c-2 shall be combined with the tensile stresses from regional bending of the web as defined in Article 5.10.4.3.1d to

C5.10.4.3.1c

Figure C5.10.4.3.1c-1 illustrates the concept of an unreinforced cover concrete beam to be investigated for cracking. Experience has shown that a vertical stack of more than three ducts can result in cracking of the cover concrete. When more than three ducts are required, it is recommended that at least 1.5 in. spacing be provided between the upper and lower ducts of the two stacks.

The resistance factor is based on successful performance of curved post-tensioned box girder bridges in California.

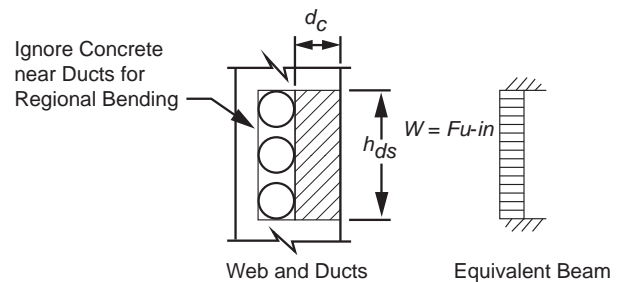

Figure C5.10.4.3.1c-1—Hypothetical Unreinforced Concrete Cover Beam

evaluate the potential for cracking of the cover concrete. If combined tensile stresses exceed the cracking stresses given by Eq. 5.10.4.3.1c-4, ducts shall be restrained by stirrup and duct tie reinforcement.

$$f_{cr} = \phi f_r \quad (5.10.4.3.1c-3)$$

where:

$$\phi = 0.85 \quad (5.10.4.3.1c-4)$$

5.10.4.3.1d—Regional Bending

The regional flexural effects of in-plane forces shall be taken as:

$$M_u = \frac{\phi \Sigma F_{u-in} h_c}{4} \quad (5.10.4.3.1d-1)$$

where:

- ϕ_{cont} = 0.6 continuity factor for interior webs; 0.7 continuity factor for exterior webs
 h_c = span of the web between the top and bottom slabs measured along the axis of the web as shown in Figure C5.10.4.3.1c-1.

For curved girders, the local flexural and shear effects of out-of-plane forces as described in Article 5.10.4.3.2 shall be evaluated.

When curved ducts for tendons other than those crossing at approximately 90 degrees are located so that the direction of the radial force from one tendon is toward another, confinement of the ducts shall be provided by:

- Spacing the ducts to ensure adequate nominal shear resistance, as specified in Eq. 5.10.4.3.1b-1 or
- Providing confinement reinforcement to resist the radial force.

5.10.4.3.2—Out-of-Plane Force Effects

Out-of-plane force effects due to the wedging action of strands against the duct wall may be estimated as:

$$F_{u-out} = \frac{P_u}{\pi R} \quad (5.10.4.3.2-1)$$

where:

- F_{u-out} = out-of-plane force effect per unit length of tendon (kip/ft)
 P_u = tendon force, factored as specified in Article 3.4.3 (kip)
 R = radius of curvature of the tendon in a vertical plane at the considered location (ft)

C5.10.4.3.1d

When determining tensile stresses for the purpose of evaluating the potential for cracking of the cover concrete as specified in Article 5.10.4.3.1c, the effect of regional bending is combined with bending of the local concrete cover beam. It is recommended that the effect of stirrups in resisting bending be ignored, and that the ducts be considered as voids in the transverse section of the webs.

The wedging action of strands within the duct due to vertical curvature of the tendon can exacerbate tendon pullout resulting from horizontal curvature of the tendon as described in Articles 5.10.4.3.1b and 5.10.4.3.1c.

C5.10.4.3.2

Out-of-plane forces in multistrand, post-tensioning tendons are caused by the spreading of the strands or wires within the duct, as shown in Figure C5.10.4.3.2-1. Small out-of-plane forces may be resisted by concrete in shear; otherwise, spiral reinforcement is most effective to resist out-of-plane forces. In horizontally curved bridges, out-of-plane forces due to the vertical curvature of tendons should be added to in-plane forces resulting from horizontal curvature of the tendons.

If the factored shear resistance given by Eq. 5.10.4.3.1b-1 is not adequate, local confining reinforcement shall be provided throughout the curved tendon segments to resist all of the out-of-plane forces, preferably in the form of spiral reinforcement.

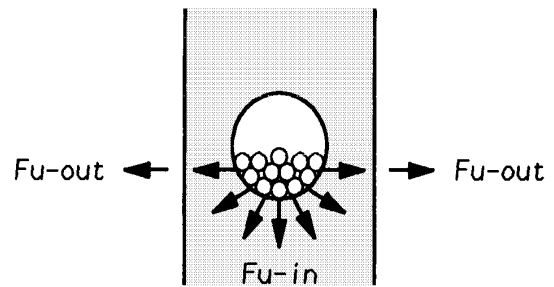

TENDON AT STRESSING LOAD
Large radial forces due to "flattening out" of tendon bundle initiate cracking in vicinity of sharpest curvature.

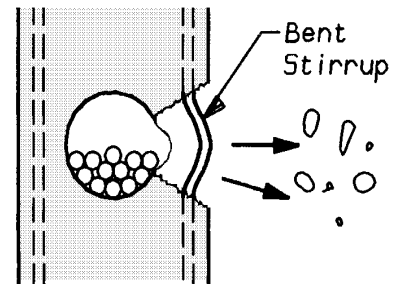

FAILURE
Side face rupture at point of sharpest curvature.

Figure C5.10.4.3.2-1—Effects of Out-of-Plane Forces

5.10.5—External Tendon Supports

Unless a vibration analysis indicates otherwise, the unsupported length of external tendons shall not exceed 25.0 ft.

5.10.6—Transverse Reinforcement for Compression Members

5.10.6.1—General

The provisions of Article 5.10.11 shall also apply to design and detailing in Seismic Zones 2, 3, and 4.

Transverse reinforcement for compression members may consist of either spirals or ties.

5.10.6.2—Spirals

Spiral reinforcement for compression members other than piles shall consist of one or more evenly spaced continuous spirals of either deformed or plain bar or wire with a minimum diameter of 0.375 in. The reinforcement shall be arranged so that all primary longitudinal reinforcement is contained on the inside of, and in contact with, the spirals.

C5.10.6.1

Article 5.10.11.2 applies to Seismic Zone 1 but has no additional requirements for transverse reinforcement for compression members.

The clear spacing between the bars of the spiral shall not be less than either 1.0 in. or 1.33 times the maximum size of the aggregate. The center-to-center spacing shall not exceed 6.0 times the diameter of the longitudinal bars or 6.0 in.

Except as specified in Articles 5.10.11.3 and 5.10.11.4.1 for Seismic Zones 2, 3, and 4, spiral reinforcement shall extend from the footing or other support to the level of the lowest horizontal reinforcement of the supported members.

Anchorage of spiral reinforcement shall be provided by 1.5 extra turns of spiral bar or wire at each end of the spiral unit. For Seismic Zones 2, 3, and 4, the extension of transverse reinforcement into connecting members shall meet the requirements of Article 5.10.11.4.3.

Splices in spiral reinforcement may be one of the following:

- Lap splices of 48.0 uncoated bar diameters, 72.0 coated bar diameters, or 48.0 wire diameters;
- Approved mechanical connectors; or
- Approved welded splices.

5.10.6.3—Ties

In tied compression members, all longitudinal bars or bundles shall be enclosed by lateral ties that shall be equivalent to:

- No. 3 bars for No. 10 or smaller bars,
- No. 4 bars for No. 11 or larger bars, and
- No. 4 bars for bundled bars.

The spacing of ties along the longitudinal axis of the compression member shall not exceed the least dimension of the compression member or 12.0 in. Where two or more bars larger than No. 10 are bundled together, the spacing shall not exceed half the least dimension of the member or 6.0 in.

Deformed wire or welded wire fabric of equivalent area may be used instead of bars.

C5.10.6.3

Figure C5.10.6.3-1 illustrates the placement of restraining ties in compression members which are not designed for plastic hinging.

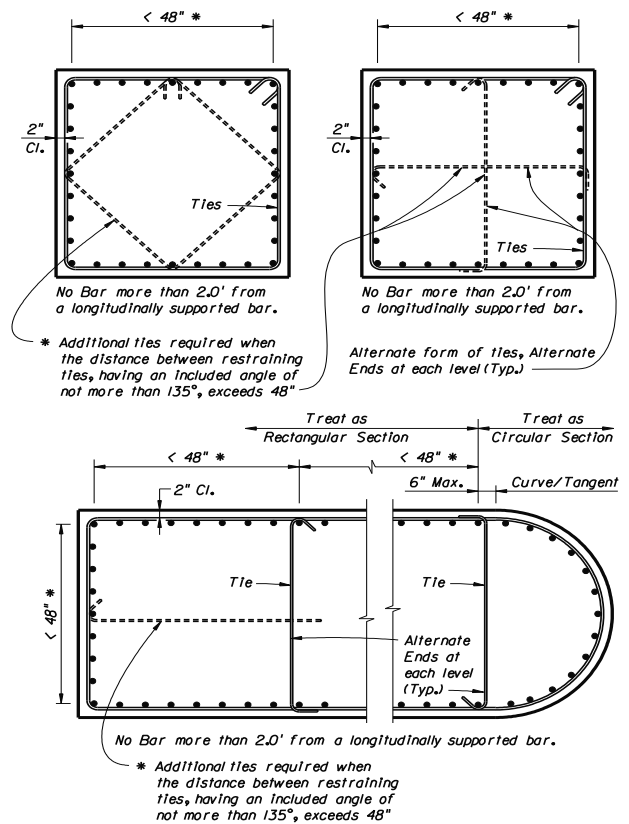

Figure C5.10.6.3-1—Acceptable Tie Arrangements

No longitudinal bar or bundle shall be more than 24.0 in., measured along the tie, from a restrained bar or bundle. A restrained bar or bundle is one which has lateral support provided by the corner of a tie having an included angle of not more than 135 degrees. Where the column design is based on plastic hinging capability, no longitudinal bar or bundle shall be farther than 6.0 in. clear on each side along the tie from such a laterally supported bar or bundle and the tie reinforcement shall meet the requirements of Articles 5.10.11.4.1d through 5.10.11.4.1f. Where the bars or bundles are located around the periphery of a circle, a complete circular tie may be used if the splices in the ties are staggered.

Ties shall be located vertically not more than half a tie spacing above the footing or other support and not more than half a tie spacing below the lowest horizontal reinforcement in the supported member.

5.10.7—Transverse Reinforcement for Flexural Members

Compression reinforcement in flexural members, except deck slabs, shall be enclosed by ties or stirrups satisfying the size and spacing requirements of Article 5.10.6 or by welded wire fabric of equivalent area.

5.10.8—Shrinkage and Temperature Reinforcement

Reinforcement for shrinkage and temperature stresses shall be provided near surfaces of concrete exposed to daily temperature changes and in structural mass concrete. Temperature and shrinkage reinforcement to ensure that the total reinforcement on exposed surfaces is not less than that specified herein.

Reinforcement for shrinkage and temperature may be in the form of bars, welded wire fabric, or prestressing tendons.

For bars or welded wire fabric, the area of reinforcement per foot, on each face and in each direction, shall satisfy:

$$A_s \geq \frac{1.30bh}{2(b+h)f_y} \tag{5.10.8-1}$$

$$0.11 \leq A_s \leq 0.60 \tag{5.10.8-2}$$

where:

- A_s = area of reinforcement in each direction and each face (in.²/ft)
- b = least width of component section (in.)
- h = least thickness of component section (in.)
- f_y = specified yield strength of reinforcing bars ≤75 ksi

Columns in Seismic Zones 2, 3, and 4 are designed for plastic hinging. The plastic hinge zone is defined in Article 5.10.11.4.1c. Additional requirements for transverse reinforcement for bridges in Seismic Zones 2, 3, and 4 are specified in Articles 5.10.11.3 and 5.10.11.4.1. Plastic hinging may be used as a design strategy for other extreme events, such as ship collision.

C5.10.8

The comparable equation in ACI was written for slabs with the reinforcement being distributed equally to both surfaces of the slabs.

The requirements of this Article are based on ACI 318 and 207.2R. The coefficient in Eq. 5.10.8-1 is the product of 0.0018, 60 ksi, and 12.0 in./ft and, therefore, has the units kips/in.-ft.

Eq. 5.10.8-1 is written to show that the total required reinforcement, $A_s = 0.0018bh$, is distributed uniformly around the perimeter of the component. It provides a more uniform approach for components of any size. For example, a 30.0 ft high × 1.0 ft thick wall section requires 0.126 in.²/ft in each face and each direction; a 4.0 ft × 4.0 ft component requires 0.260 in.²/ft in each face and each direction; and a 5.0 ft × 20.0 ft footing requires 0.520 in.²/ft in each face and each direction. For circular or other shapes the equation becomes:

$$A_s \geq \frac{1.3A_g}{Perimeter(f_y)} \tag{C5.10.8-1}$$

Where the least dimension varies along the length of wall, footing, or other component, multiple sections should be examined to represent the average condition at each section. Spacing shall not exceed:

- 3.0 times the component thickness, or 18.0 in.
- 12.0 in. for walls and footings greater than 18.0 in. thick
- 12.0 in. for other components greater than 36.0 in. thick

For components 6.0 in. or less in thickness the minimum steel specified may be placed in a single layer. Shrinkage and temperature steel shall not be required for:

- End face of walls 18 in. or less in thickness
- Side faces of buried footings 36 in. or less in thickness
- Faces of all other components, with smaller dimension less than or equal to 18.0 in.

If prestressing tendons are used as steel for shrinkage and temperature reinforcement, the tendons shall provide a minimum average compressive stress of 0.11 ksi on the gross concrete area through which a crack plane may extend, based on the effective prestress after losses. Spacing of tendons should not exceed either 72.0 in. or the distance specified in Article 5.10.3.4. Where the spacing is greater than 54.0 in., bonded reinforcement shall be provided between tendons, for a distance equal to the tendon spacing.

5.10.9—Post-Tensioned Anchorage Zones

5.10.9.1—General

Anchorage shall be designed at the strength limit states for the factored jacking forces as specified in Article 3.4.3.

For anchorage zones at the end of a component or segment, the transverse dimensions may be taken as the depth and width of the section but not larger than the longitudinal dimension of the component or segment. The longitudinal extent of the anchorage zone in the direction of the tendon shall not be less than the greater of the transverse dimensions of the anchorage zone and shall not be taken as more than one and one-half times that dimension.

For intermediate anchorages, the anchorage zone shall be considered to extend in the direction opposite to the anchorage force for a distance not less than the larger of the transverse dimensions of the anchorage zone.

Permanent prestress of 0.11 ksi is equivalent to the resistance of the steel specified in Eq. 5.10.8-1 at the strength limit state. The 0.11 ksi prestress should not be added to that required for the strength or service limit states. It is a minimum requirement for shrinkage and temperature crack control.

The spacing of stress-relieving joints should be considered in determining the area of shrinkage and temperature reinforcement.

Surfaces of interior walls of box girders need not be considered to be exposed to daily temperature changes.

See also Article 12.14.5.8 for additional requirements for three-sided buried structures.

C5.10.9.1

With slight modifications, the provisions of Article 5.10.9 are also applicable to the design of reinforcement under high-load capacity bearings.

The anchorage zone is geometrically defined as the volume of concrete through which the concentrated prestressing force at the anchorage device spreads transversely to a more linear stress distribution across the entire cross-section at some distance from the anchorage device.

Within the anchorage zone, the assumption that plane sections remain plane is not valid.

The dimensions of the anchorage zone are based on the principle of St. Venant. Provisions for components with a length smaller than one of its transverse dimensions were included to address cases such as transverse prestressing of bridge decks, as shown in Figure C5.10.9.1-1.

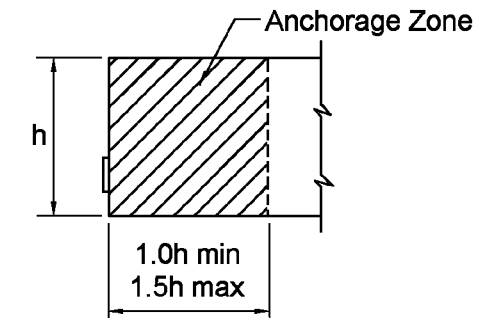

a) If Transverse Dimension of Cross Section or Center-to-Center Spacing Between Tendons Are Smaller than Length.

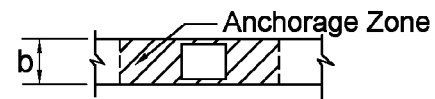
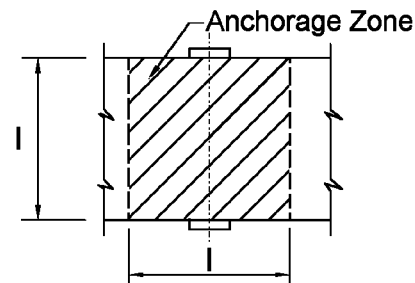

b) If Transverse Dimension of Cross Section or Center-to-Center Spacing Between Tendons Are Greater than Length.

Figure C5.10.9.1-1—Geometry of the Anchorage Zones

5.10.9.2—General Zone and Local Zone

5.10.9.2.1—General

For design purposes, the anchorage zone shall be considered as comprised of two regions:

- The general zone, for which the provisions of Article 5.10.9.2.2 apply, and
- The local zone, for which the provisions of Article 5.10.9.2.3 apply.

C5.10.9.2.1

For intermediate anchorages, large tensile stresses may exist behind the anchor. These tensile stresses result from the compatibility of deformations ahead of and behind the anchorage.

Figure C5.10.9.1-1 illustrates the distinction between the local and the general zone. The region subjected to tensile stresses due to spreading of the tendon force into the structure is the general zone (Figure C5.10.9.1-1a). The region of high compressive stresses immediately ahead of the anchorage device is the local zone (Figure C5.10.9.1-1b).

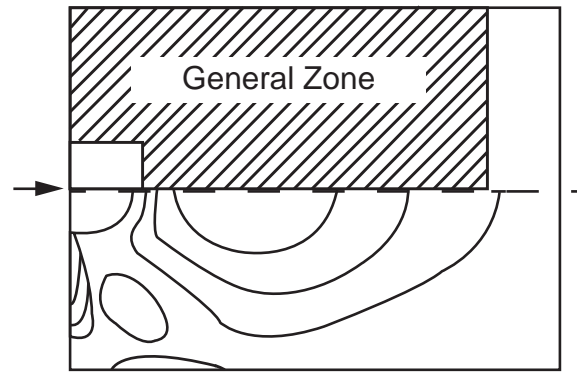

a) Principal Tensile Stresses and the General Zone

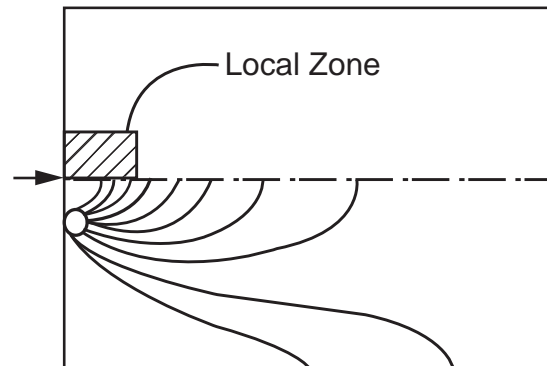

b) Principal Compressive Stresses and the Local Zone

Figure C5.10.9.2.1-1—General Zone and Local Zone

5.10.9.2.2—General Zone

The extent of the general zone shall be taken as identical to that of the overall anchorage zone including the local zone, defined in Article 5.10.9.1.

Design of general zones shall comply with the requirements of Article 5.10.9.3.

5.10.9.2.3—Local Zone

Design of local zones shall either comply with the requirements of Article 5.10.9.7 or be based on the results of acceptance tests as specified in Article 5.10.9.7.3 and described in Article 10.3.2.3 of *AASHTO LRFD Bridge Construction Specifications*.

For design of the local zone, the effects of high bearing pressure and the application of confining reinforcement shall be considered.

Anchorage devices based on the acceptance test of *AASHTO LRFD Bridge Construction Specifications*, Article 10.3.2.3, shall be referred to as special anchorage devices.

C5.10.9.2.2

In many cases, the general zone and the local zone can be treated separately, but for small anchorage zones, such as in slab anchorages, local zone effects, such as high bearing and confining stresses, and general zone effects, such as tensile stresses due to spreading of the tendon force, may occur in the same region. The designer should account for the influence of overlapping general zones.

C5.10.9.2.3

The local zone is defined as either the rectangular prism, or, for circular or oval anchorages, the equivalent rectangular prism of the concrete surrounding and immediately ahead of the anchorage device and any integral confining reinforcement. The dimensions of the local zone are defined in Article 5.10.9.7.1.

The local zone is expected to resist the high local stresses introduced by the anchorage device and to transfer them to the remainder of the anchorage zone. The resistance of the local zone is more influenced by the characteristics of the anchorage device and its confining reinforcement than by either the geometry or the loading of the structure.

5.10.9.2.4—Responsibilities

The Engineer of Record shall be responsible for the overall design and approval of working drawings for the general zone, including the location of the tendons and anchorage devices, general zone reinforcement, the stressing sequence, and the design of the local zone for anchorage devices based on the provisions of Article 5.10.9.7. The contract documents shall specify that all working drawings for the local zone must be approved by the Engineer of Record.

The anchorage device Supplier shall be responsible for furnishing anchorage devices that satisfy the anchor efficiency requirements of *AASHTO LRFD Bridge Construction Specifications*, Article 10.3.2. If special anchorage devices are used, the anchorage device Supplier shall be responsible for furnishing anchorage devices that also satisfy the acceptance test requirements of Article 5.10.9.7.3 and of *AASHTO LRFD Bridge Construction Specifications*, Article 10.3.2.3. This acceptance test and the anchor efficiency test shall be conducted by an independent testing agency acceptable to the Engineer of Record. The anchorage device supplier shall provide records of the acceptance test in conformance with *AASHTO LRFD Bridge Construction Specifications*, Article 10.3.2.3.12, to the Engineer of Record and to the Constructor and shall specify auxiliary and confining reinforcement, minimum edge distance, minimum anchor spacing, and minimum concrete strength at time of stressing required for proper performance of the local zone.

The responsibilities of the Constructor shall be as specified in the *AASHTO LRFD Bridge Construction Specifications*, Article 10.4.

5.10.9.3—Design of the General Zone

5.10.9.3.1—Design Methods

For the design of general zones, the following design methods, conforming to the requirements of Article 5.10.9.3.2, may be used:

- Equilibrium-based inelastic models, generally termed as “strut-and-tie models;”
- Refined elastic stress analyses as specified in Section 4; or
- Other approximate methods, where applicable.

The effects of stressing sequence and three-dimensional effects due to concentrated jacking loads shall be investigated. Three-dimensional effects may be analyzed using three-dimensional analysis procedures or may be approximated by considering separate submodels for two or more planes, in which case the interaction of the submodels should be

C5.10.9.2.4

The Engineer of Record has the responsibility to indicate the location of individual tendons and anchorage devices. Should the Designer initially choose to indicate only total tendon force and eccentricity, he still retains the responsibility of approving the specific tendon layout and anchorage arrangement submitted by a post-tensioning specialist or the Contractor. The Engineer is responsible for the design of general zone reinforcement required by the approved tendon layout and anchorage device arrangement.

The use of special anchorage devices does not relieve the Engineer of Record from his responsibility to review the design and working drawings for the anchorage zone to ensure compliance with the anchorage device Supplier's specifications.

The anchorage device Supplier has to provide information regarding all requirements necessary for the satisfactory performance of the local zone to the Engineer of Record and to the Contractor. Necessary local zone confinement reinforcement has to be specified by the Supplier.

C5.10.9.3.1

The design methods referred to in this Article are not meant to preclude other recognized and verified procedures. In many anchorage applications where substantial or massive concrete regions surround the anchorages and where the members are essentially rectangular without substantial deviations in the force flow path, the approximate procedures of Article 5.10.9.6 can be used. However, in the post-tensioning of thin sections, flanged sections, and irregular sections or where the tendons have appreciable curvature, the more general procedures of Article 5.10.9.4 and 5.10.9.5 may be required.

Different anchorage force combinations have a significant effect on the general zone stresses. Therefore, it is important to consider not only the final stage of a stressing sequence with all tendons stressed but also the intermediate stages.

The provision concerning three-dimensional effects was included to alert the Designer to effects

considered, and the model loads and results should be consistent.

The factored concrete compressive stress for the general zone shall not exceed $0.7 \phi f'_{ci}$. In areas where the concrete may be extensively cracked at ultimate due to other force effects, or if large inelastic rotations are expected, the factored compressive stress shall be limited to $0.6 \phi f'_{ci}$.

The tensile strength of the concrete shall be neglected in the design of the general zone.

The nominal tensile stress of bonded reinforcement shall be limited to f_y for both nonprestressed reinforcement and bonded prestressed reinforcement. The nominal tensile stress of unbonded prestressed reinforcement shall be limited to $f_{pe} + 15,000$ psi.

The contribution of any local zone reinforcement to the strength of the general zone may be conservatively neglected in the design.

5.10.9.3.2—Design Principles

Compressive stresses in the concrete ahead of basic anchorage devices shall satisfy the requirements of Article 5.10.9.7.2.

The compressive stresses in the concrete ahead of the anchorage device shall be investigated at a distance, measured from the concrete bearing surface, not less than:

- The depth to the end of the local confinement reinforcement, or
- The smaller lateral dimension of the anchorage device.

These compressive stresses may be determined using the strut-and-tie model procedures of Article 5.10.9.4, an elastic stress analysis according to Article 5.10.9.5, or the approximate method outlined in Article 5.10.9.6.2.

The magnitude of the bursting force, T_{bursts} , and its corresponding distance from the loaded surface, d_{burst} , may be determined using the strut-and-tie model procedures of Article 5.10.9.4, an elastic stress analysis according to Article 5.10.9.5, or the approximate method outlined in Article 5.10.9.6.3. Three-dimensional effects shall be considered for the determination of the bursting reinforcement requirements.

Compressive stresses shall also be checked where geometry or loading discontinuities within or ahead of the anchorage zone may cause stress concentrations.

Resistance to bursting forces shall be provided by nonprestressed or prestressed reinforcement or in the form of spirals, closed hoops, or anchored transverse ties. This reinforcement shall resist the total bursting force. The following guidelines for the arrangement and anchorage of bursting reinforcement should apply:

perpendicular to the main plane of the member, such as bursting forces in the thin direction of webs or slabs. For example, in members with thin rectangular cross-sections, bursting forces not only exist in the major plane of the member but also perpendicular to it. In many cases, these effects can be determined independently for each direction, but some applications require a fully three-dimensional analysis, i.e., diaphragms for the anchorage of external tendons.

C5.10.9.3.2

Good detailing and quality workmanship are essential for the satisfactory performance of anchorage zones. Sizes and details for anchorage zones should respect the need for tolerances on the bending, fabrication, and placement of reinforcement; the size of aggregate; and the need for placement and sound consolidation of the concrete.

The interface between the confined concrete of the local zone and the usually unconfined concrete of the general zone is critical. The provisions of this Article define the location where concrete stresses should be investigated.

The bursting force is the tensile force in the anchorage zone acting ahead of the anchorage device and transverse to the tendon axis. Bursting forces are caused by the lateral spreading of the prestressing forces concentrated at the anchorage.

The guidelines for the arrangement of the bursting reinforcement direct the Designer toward reinforcement patterns that reflect the elastic stress distribution. The experimental test results show that this leads to satisfactory behavior at the service limit state by limiting the extent and opening of cracks and at the strength limit state by limiting the required amount of redistribution of forces in the anchorage zone (Sanders, 1990). A uniform distribution of the bursting reinforcement with its centroid at d_{burst} , as shown in Figure C5.10.9.3.2-1, may be considered acceptable.

- Reinforcement is extended over the full-width of the member and anchored as close to the outer faces of the member as cover permits;
- Reinforcement is distributed ahead of the loaded surface along both sides of the tendon throughout a distance taken as the lesser of $2.5 d_{burst}$ for the plane considered and 1.5 times the corresponding lateral dimension of the section, where d_{burst} is specified by Eq. 5.10.9.6.3-2;
- The centroid of the bursting reinforcement coincides with the distance d_{burst} used for the design; and
- Spacing of reinforcement is not greater than either 24.0 bar diameters or 12.0 in.

The edge tension forces may be determined using the strut-and-tie models, procedures of Article 5.10.9.4, elastic analysis according to Article 5.10.9.5, or approximate methods of Article 5.10.9.6.4.

For multiple anchorages with a center-to-center spacing of less than 0.4 times the depth of the section, the spalling force shall not be taken to be less than two percent of the total factored tendon force. For larger spacings, the spalling forces shall be determined by analysis.

Edge tension forces are tensile forces in the anchorage zone acting parallel and close to the transverse edge and longitudinal edges of the member. The transverse edge is the surface loaded by the anchors. The tensile force along the transverse edge is referred to as spalling force. The tensile force along the longitudinal edge is referred to as longitudinal edge tension force.

Strut-and-tie models may be used for larger anchor spacings.

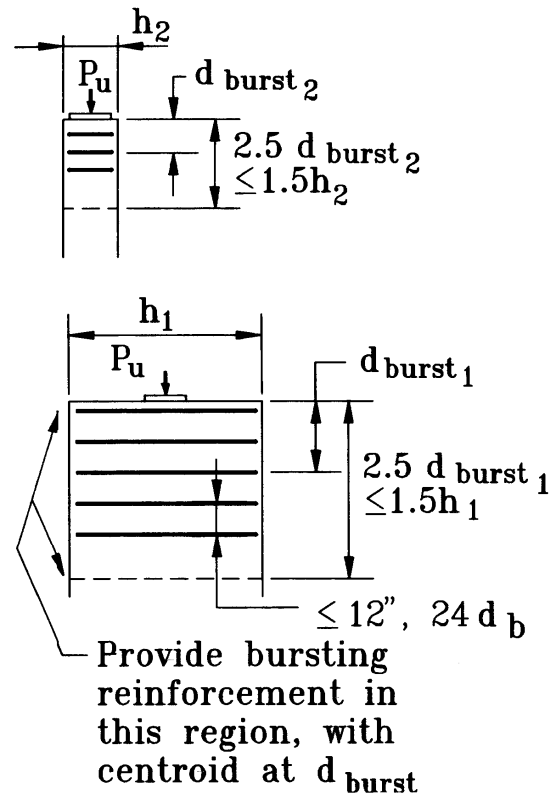

Figure C5.10.9.3.2-1—Arrangement for Bursting Reinforcement

Resistance to edge tension forces shall be provided by reinforcement located close to the longitudinal and transverse edge of the concrete. Arrangement and anchorage of the edge tension reinforcement shall satisfy the following:

- Specified spalling reinforcement is extended over the full-width of the member,
- Spalling reinforcement between multiple anchorage devices effectively ties the anchorage devices together, and
- Longitudinal edge tension reinforcement and spalling reinforcement for eccentric anchorage devices are continuous; the reinforcement extends along the tension face over the full length of the anchorage zone and along the loaded face from the longitudinal edge to the other side of the eccentric anchorage device or group of anchorage devices.

Spalling forces are induced in concentrically loaded anchorage zones, eccentrically loaded anchorage zones, and anchorage zones for multiple anchors. Longitudinal edge tension forces are induced where the resultant of the anchorage forces causes eccentric loading of the anchorage zone.

For multiple anchorages, the spalling forces are required for equilibrium, and provision for adequate reinforcement is essential for the ultimate load capacity of the anchorage zone, as shown in Figure C5.10.9.3.2-1. These tension forces are similar to the tensile tie forces existing between individual footings supporting deep walls. In most cases, the minimum spalling reinforcement specified herein will control.

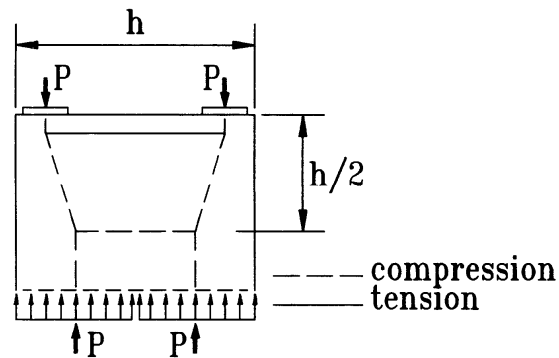

Figure C5.10.9.3.2-2—Path of Forces for Multiple Anchorages

Figure C5.10.9.3.2-3 illustrates the location of the edge tension forces.

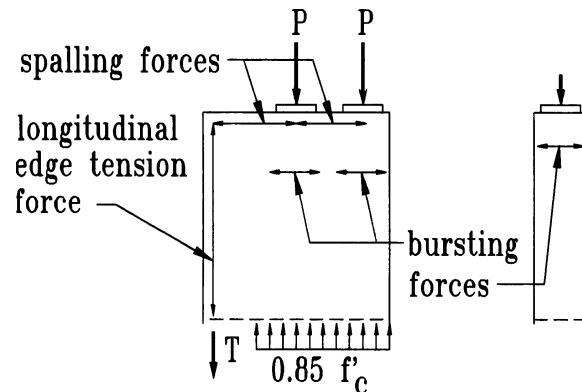

Figure C5.10.9.3.2-3—Edge Tension Forces

The minimum spalling force for design is two percent of the total post-tensioning force. This value is smaller than the four percent proposed by Guyon (1953) and reflects both analytical and experimental findings showing that Guyon's values for spalling forces are rather conservative and that spalling cracks are rarely observed in experimental studies (Base et al., 1966; Beeby, 1983).

Figure C5.10.9.3.2-4 illustrates the reinforcement requirements for anchorage zones.

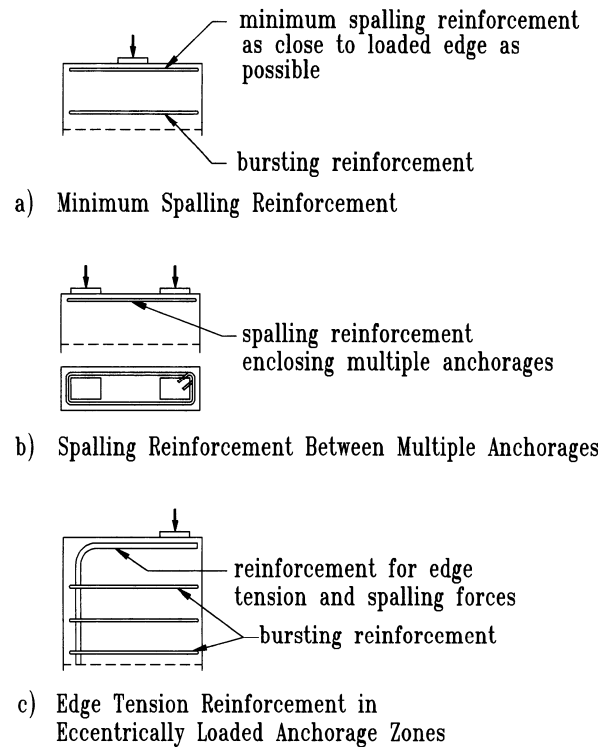

Figure C5.10.9.3.2-4—Arrangement of Anchorage Zone Reinforcement

5.10.9.3.3—Special Anchorage Devices

Where special anchorage devices that do not satisfy the requirements of Article 5.10.9.7.2 are to be used, reinforcement similar in configuration and at least equivalent in volumetric ratio to the supplementary skin reinforcement permitted under the provisions of the *AASHTO LRFD Bridge Construction Specifications*, Article 10.3.2.3.4, shall be furnished in the corresponding regions of the anchorage zone.

5.10.9.3.4—Intermediate Anchorages

5.10.9.3.4a—General

Intermediate anchorages shall not be used in regions where significant tension is generated behind the anchor from other loads. Whenever practical, blisters should be located in the corner between flange and webs or shall be extended over the full flange width or web height to form a continuous rib. If isolated blisters must be used on a flange or web, local shear bending, and direct force effects shall be considered in the design.

C5.10.9.3.4a

Intermediate anchorages are usually used in segmented construction. Locating anchorage blisters in the corner between flange and webs significantly reduces local force effects at intermediate anchorages. Lesser reduction in local effects can be obtained by increasing the width of the blister to match the full-width of the flange or full-depth of the web to which the blister is attached.

For flange thickness ranging from 5.0 to 9.0 in., an upper limit of 12, Grade 270 ksi, 0.5-in. diameter strands is recommended for tendons anchored in blisters supported only by the flange. The anchorage force of the tendon must be carefully distributed to the flange by reinforcement.

5.10.9.3.4b—Tie-Backs

Unless otherwise specified herein, bonded reinforcement shall be provided to tie-back at least 25 percent of the intermediate anchorage unfactored stressing force into the concrete section behind the anchor. Stresses in this bonded reinforcement shall not exceed a maximum of $0.6f_y$ or 36 ksi. If permanent compressive stresses are generated behind the anchor from other loads, the amount of tie-back reinforcement may be reduced using Eq. 5.10.9.3.4b-1.

$$T_{ia} = 0.25 P_s - f_{cb} A_{cb} \quad (5.10.9.3.4b-1)$$

where:

- T_{ia} = the tie-back tension force at the intermediate anchorage (kip)
- P_s = the maximum unfactored anchorage stressing force (kip)
- f_{cb} = the unfactored dead load compressive stress in the region behind the anchor (ksi)
- A_{cb} = the area of the continuing cross-section within the extensions of the sides of the anchor plate or blister, i.e., the area of the blister or rib shall not be taken as part of the cross-section (in.²)

Tie-back reinforcement shall be placed no further than one plate width from the tendon axis. It shall be fully anchored so that the yield strength can be developed at a distance of one plate width or half the length of the blister or rib ahead of the anchor as well as at the same distance behind the anchor. The centroid of this reinforcement shall coincide with the tendon axis, where possible. For blisters and ribs, the reinforcement shall be placed in the continuing section near that face of the flange or web from which the blister or rib is projecting.

5.10.9.3.4c—Blister and Rib Reinforcement

Reinforcement shall be provided throughout blisters or ribs as required for shear friction, corbel action, bursting forces, and deviation forces due to tendon curvature. This reinforcement shall extend as far as possible into the flange or web and be developed by standard hooks bent around transverse bars or equivalent. Spacing shall not exceed the smallest of blister or rib height at anchor, blister width, or 6.0 in.

Reinforcement shall be provided to resist local bending in blisters and ribs due to eccentricity of the tendon force and to resist lateral bending in ribs due to tendon deviation forces.

Reinforcement, as specified in Article 5.10.9.3.2, shall be provided to resist tensile forces due to transfer of the anchorage force from the blister or rib into the overall structure.

C5.10.9.3.4c

This reinforcement is normally provided in the form of ties or U-stirrups, which encase the anchorage and tie it effectively into the adjacent web and flange.

5.10.9.3.5—Diaphragms

For tendons anchored in diaphragms, concrete compressive stresses shall be limited within the diaphragm as specified in Article 5.10.9.3.2. Compressive stresses shall also be investigated at the transition from the diaphragm to webs and flanges of the member.

Reinforcement shall be provided to ensure full transfer of diaphragm anchor loads into the flanges and webs of the girder. Requirements for shear friction reinforcement between the diaphragm and web and between the diaphragm and flanges shall be checked.

Reinforcement shall also be provided to tie-back deviation forces due to tendon curvature.

5.10.9.3.6—Multiple Slab Anchorages

Unless a more detailed analysis is made, the minimum reinforcement specified herein to resist bursting force and edge tension force shall be provided.

Reinforcement shall be provided to resist the bursting force. This reinforcement shall be anchored close to the faces of the slab with standard hooks bent around horizontal bars or equivalent. Minimum reinforcement should be two No. 3 bars per anchor located at a distance equal to one-half the slab thickness ahead of the anchor.

Reinforcement shall be provided to resist edge tension forces, T_1 , between anchorages and bursting forces, T_2 , ahead of the anchorages. Edge tension reinforcement shall be placed immediately ahead of the anchors and shall effectively tie adjacent anchors together. Bursting reinforcement shall be distributed over the length of the anchorage zones.

$$T_1 = 0.10 P_u \left(1 - \frac{a}{s} \right) \quad (5.10.9.3.6-1)$$

$$T_2 = 0.20 P_u \left(1 - \frac{a}{s} \right) \quad (5.10.9.3.6-2)$$

where:

- T_1 = the edge tension force (kip)
- T_2 = the bursting force (kip)
- P_u = the factored tendon load on an individual anchor (kip)
- a = the anchor plate width (in.)
- s = the anchorage spacing (in.)

For slab anchors with an edge distance of less than two plate widths or one slab thickness, the edge tension

C5.10.9.3.5

Diaphragms anchoring post-tensioning tendons may be designed following the general guidelines of Schlaich et al. (1987), Breen and Kashima (1991), and Wollmann (1992). A typical diaphragm anchoring post-tensioning tendons usually behaves as a deep beam supported on three sides by the top and bottom flanges and the web wall. The magnitude of the bending tensile force on the face of the diaphragm opposite the anchor can be determined using strut-and-tie models or elastic analysis. Approximate methods, such as the symmetric prism, suggested by Guyon (1953), do not apply.

The more general methods of Article 5.10.9.4 or Article 5.10.9.5 are used to determine this reinforcement.

C5.10.9.3.6

Reinforcement to resist bursting force is provided in the direction of the thickness of the slab and normal to the tendon axis in accordance with Article 5.10.9.3.2.

Reinforcement to resist edge tension force is placed in the plane of the slab and normal to the tendon axis.

The use of hairpins provides better confinement to the edge region than the use of straight bars.

reinforcement shall be proportioned to resist 25 percent of the factored tendon load. This reinforcement should be in the form of hairpins and shall be distributed within one plate width ahead of the anchor. The legs of the hairpin bars shall extend from the edge of the slab past the adjacent anchor but not less than a distance equal to five plate widths plus development length.

5.10.9.3.7—Deviation Saddles

Deviation saddles shall be designed using the strut-and-tie model or using methods based on test results. A load factor of 1.7 shall be used with the maximum deviation force. If using a method based on test results, a resistance factor of 0.90 shall be used for direct tension and 0.85 shall be used for shear.

5.10.9.4—Application of the Strut-and-Tie Model to the Design of General Zone

5.10.9.4.1—General

The flow of forces in the anchorage zone may be approximated by a strut-and-tie model as specified in Article 5.6.3.

All forces acting on the anchorage zone shall be considered in the selection of a strut-and-tie model which should follow a load path from the anchorages to the end of the anchorage zone.

C5.10.9.3.7

Deviation saddles are disturbed regions of the structure and can be designed using the strut-and-tie model. Tests of scale-model deviation saddles have provided important information on the behavior of deviation saddles regions. Design and detailing guidelines are presented in Beaupre et al. (1988).

C5.10.9.4.1

A conservative estimate of the resistance of a concrete structure or member may be obtained by application of the lower bound theorem of the theory of plasticity of structures. If sufficient ductility is present in the system, strut-and-tie models fulfill the conditions for the application of the above-mentioned theorem. Figure C5.10.9.4.1-1 shows the linear elastic stress field and a corresponding strut-and-tie model for the case of an anchorage zone with two eccentric anchors (Schlaich et al., 1987).

Because of the limited ductility of concrete, strut-and-tie models, which are not greatly different from the elastic solution in terms of stress distribution, should be selected. This procedure will reduce the required stress redistributions in the anchorage zone and ensure that reinforcement is provided where cracks are most likely to occur. Strut-and-tie models for some typical load cases for anchorage zones are shown in Figure C5.10.9.4.1-2.

Figure C5.10.9.4.1-3 shows the strut-and-tie model for the outer regions of general anchorage zones with eccentrically located anchorages. The anchorage local zone becomes a node for the strut-and-tie model and the adequacy of the node must be checked by appropriate analysis or full-scale testing.

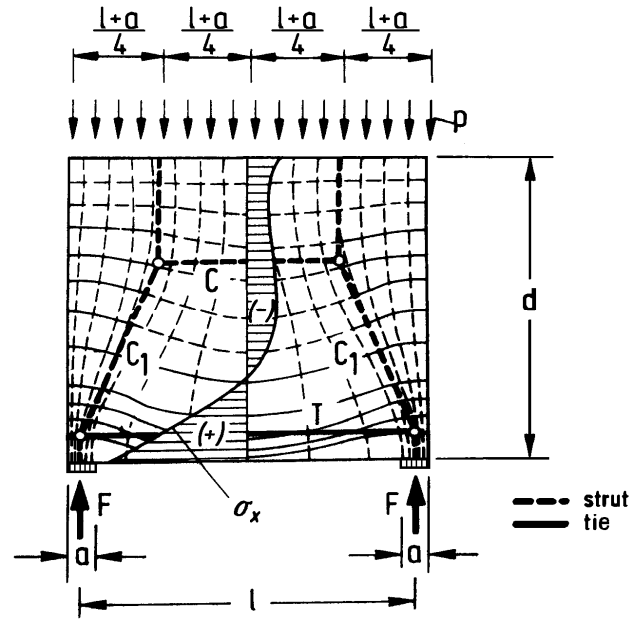

Figure C5.10.9.4.1-1—Principal Stress Field and Superimposed Strut-and-Tie Model

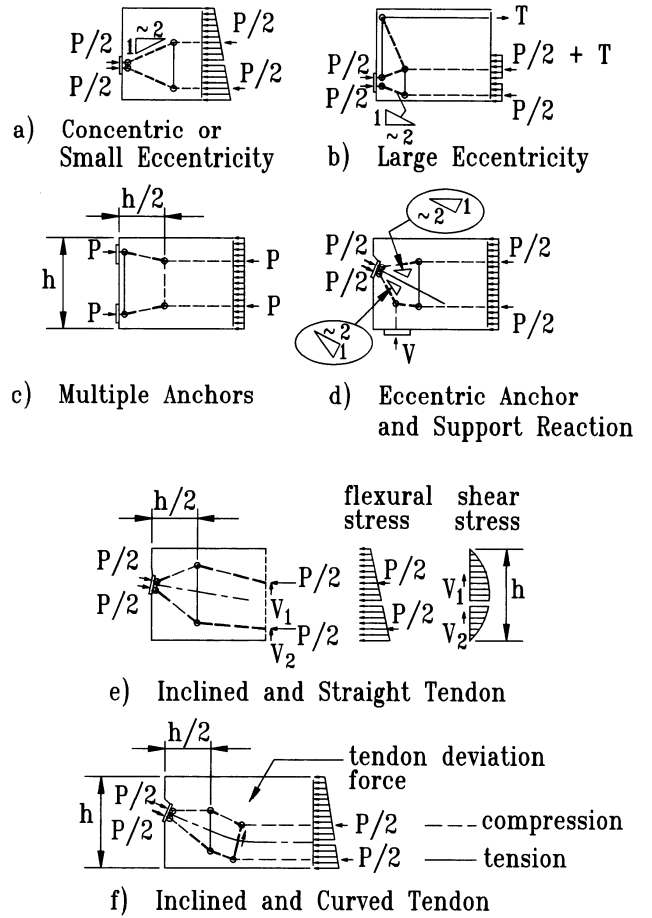

Figure C5.10.9.4.1-2—Strut-and-Tie Models for Selected Anchorage Zones

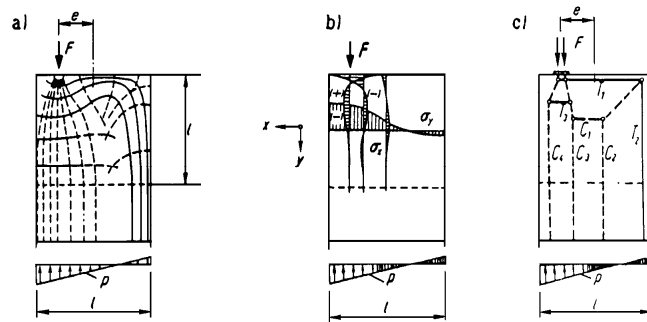

Figure C5.10.9.4.1-3—Strut-and-Tie Model for the Outer Regions of the General Zone

5.10.9.4.2—Nodes

Local zones that satisfy the requirements of Article 5.10.9.7 or Article 10.3.2.3 of *AASHTO LRFD Bridge Construction Specifications* may be considered as properly detailed and are adequate nodes. The other nodes in the anchorage zone may be considered adequate if the effective concrete stresses in the struts satisfy the requirements of Article 5.10.9.4.3, and the tension ties are detailed to develop the full yield strength of the reinforcement.

C5.10.9.4.2

Nodes are critical elements of the strut-and-tie model. The entire local zone constitutes the most critical node or group of nodes for anchorage zones. In Article 5.10.9.7, the adequacy of the local zone is ensured by limiting the bearing pressure under the anchorage device. Alternatively, this limitation may be exceeded if the adequacy of the anchorage device is proven by the acceptance test of Article 10.3.2.3 of *AASHTO LRFD Bridge Construction Specifications*.

The local zone nodes for the development of a strut-and-tie model may be selected at a depth of $a/4$ ahead of the anchorage plate, as shown in Figure C5.10.9.4.2-1.

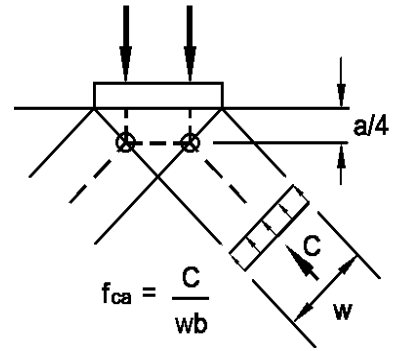

a)

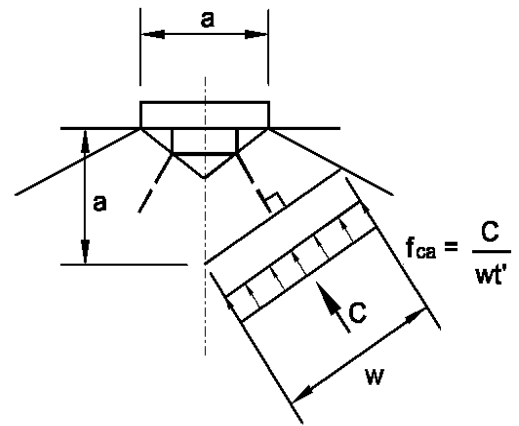

b)

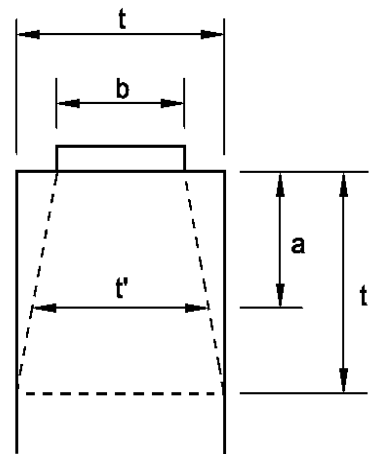

c)

Figure C5.10.9.4.2-1—Critical Sections for Nodes and Compressive Struts

5.10.9.4.3—Struts

The factored compressive stress shall not exceed the limits specified in Article 5.10.9.3.1.

In anchorage zones, the critical section for compression struts may normally be taken at the interface with the local zone node. If special anchorage devices are used, the critical section of the strut may be taken as the section whose extension intersects the axis of the tendon at a depth equal to the smaller of the depth of the local confinement reinforcement or the lateral dimension of the anchorage device.

For thin members, the dimension of the strut in the direction of the thickness of the member may be approximated by assuming that the thickness of the compression strut varies linearly from the transverse lateral dimension of the anchor at the surface of the concrete to the total thickness of the section at a depth equal to the thickness of the section.

The compression stresses should be assumed to act parallel to the axis of the strut and to be uniformly distributed over its cross-section.

5.10.9.4.4—Ties

Ties consisting of nonprestressed or prestressed reinforcement shall resist the total tensile force.

Ties shall extend beyond the nodes to develop the full-tension tie force at the node. The reinforcement layout should follow as closely as practical the paths of the assumed ties in the strut-and-tie model.

5.10.9.5—Elastic Stress Analysis

Analyses based on elastic material properties, equilibrium of forces and loads, and compatibility of strains may be used for the analysis and design of anchorage zones.

If the compressive stresses in the concrete ahead of the anchorage device are determined from an elastic analysis, local stresses may be averaged over an area equal to the bearing area of the anchorage device.

C5.10.9.4.3

For strut-and-tie models oriented on the elastic stress distribution, the nominal concrete strength specified in Article 5.10.9.3.1 is adequate. However, if the selected strut-and-tie model deviates considerably from the elastic stress distribution, large plastic deformations are required and the usable concrete strength should also be reduced if the concrete is cracked due to other load effects.

Ordinarily, the geometry of the local zone node and, thus, of the interface between strut and local zone, is determined by the size of the bearing plate and the selected strut-and-tie model, as indicated in Figure C5.10.9.4.2-1(a). Based on the acceptance test of Article 10.3.2.3 of *AASHTO LRFD Bridge Construction Specifications*, the stresses on special anchorage devices should be investigated at a larger distance from the node, assuming that the width of the strut increases with the distance from the local zone, as shown in Figure C5.10.9.4.2-1(b) (Burdet, 1990).

The determination of the dimension of the strut in the direction of the thickness of the member is illustrated in Figure C5.10.9.4.2-1(c).

C5.10.9.4.4

Because of the unreliable strength of concrete in tension, it is prudent to neglect it entirely in resisting tensile forces.

In the selection of a strut-and-tie model, only practical reinforcement arrangements should be considered. The reinforcement layout, actually detailed on the plans, should be in agreement with the selected strut-and-tie model.

C5.10.9.5

Elastic analysis of anchorage zone problems has been found acceptable and useful, even though the development of cracks in the anchorage zone may cause stress redistributions (Burdet, 1990).

Results of a linear elastic analysis can be adjusted by smoothing out local stress maxima to reflect the nonlinear behavior of concrete at higher stresses.

The location and magnitude of the bursting force should be obtained by integration of the tensile bursting stresses along the tendon path. This procedure gives a conservative estimate of the reinforcement required in the anchorage zone. A reinforcement arrangement deviating from the elastic stress distribution, i.e., a uniform distribution of bursting reinforcement, is acceptable as long as the centroid of the bursting reinforcement coincides with the location of the bursting force.

5.10.9.6—Approximate Stress Analyses and Design

5.10.9.6.1—Limitations of Application

Concrete compressive stresses ahead of the anchorage device, location and magnitude of the bursting force, and edge tension forces may be estimated using Eqs. 5.10.9.6.2-1 through 5.10.9.6.3-2, provided that:

- The member has a rectangular cross-section and its longitudinal extent is not less than the larger transverse dimension of the cross-section;
- The member has no discontinuities within or ahead of the anchorage zone;
- The minimum edge distance of the anchorage in the main plane of the member is not less than 1.5 times the corresponding lateral dimension, a , of the anchorage device;
- Only one anchorage device or one group of closely spaced anchorage devices is located in the anchorage zone; and
- The angle of inclination of the tendon, as specified in Eqs. 5.10.9.6.3-1 and 5.10.9.6.3-2, is between -5.0 degrees and $+20.0$ degrees.

C5.10.9.6.1

The equations specified herein are based on the analysis of members with rectangular cross-sections and on an anchorage zone at least as long as the largest dimension of that cross-section. For cross-sections that deviate significantly from a rectangular shape, for example I-girders with wide flanges, the approximate equations should not be used.

Discontinuities, such as web openings, disturb the flow of forces and may cause higher compressive stresses, bursting forces, or edge tension forces in the anchorage zone. Figure C5.10.9.6.1-1 compares the bursting forces for a member with a continuous rectangular cross-section and for a member with a noncontinuous rectangular cross-section. The approximate equations may be applied to standard I-girders with end blocks if the longitudinal extension of the end block is at least one girder height and if the transition from the end block to the I-section is gradual.

Anchorage devices may be treated as closely spaced if their center-to-center spacing does not exceed 1.5 times the width of the anchorage devices in the direction considered.

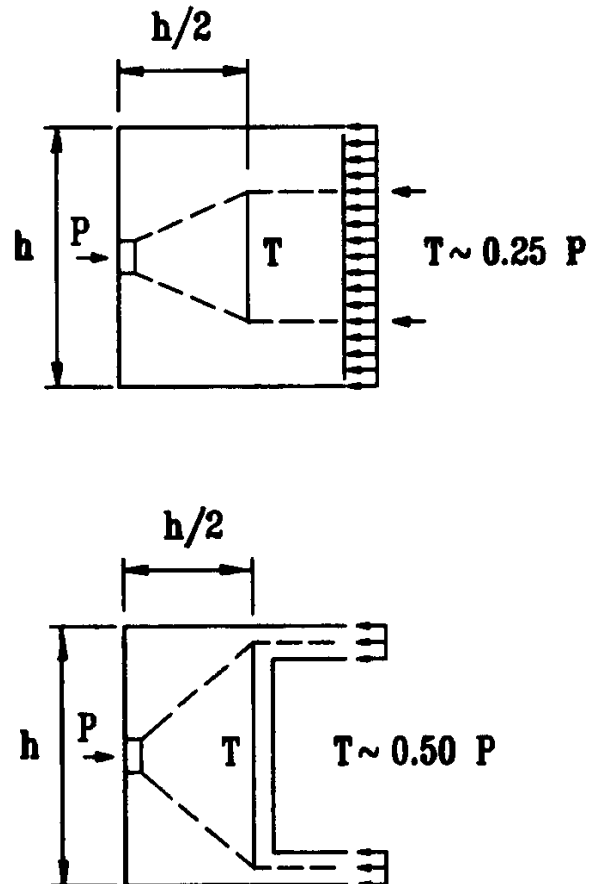

Figure C5.10.9.6.1-1—Effect of Discontinuity in Anchorage Zone

The approximate equations for concrete compressive stresses are based on the assumption that the anchor force spreads in all directions. The minimum edge distance requirement satisfies this assumption and is illustrated in Figure C5.10.9.6.1-2. The approximate equations for bursting forces are based on finite element analyses for a single anchor acting on a rectangular cross-section. Eq. 5.10.9.6.3-1 gives conservative results for the bursting reinforcement, even if the anchors are not closely spaced, but the resultant of the bursting force is located closer to the anchor than indicated by Eq. 5.10.9.6.3-2.

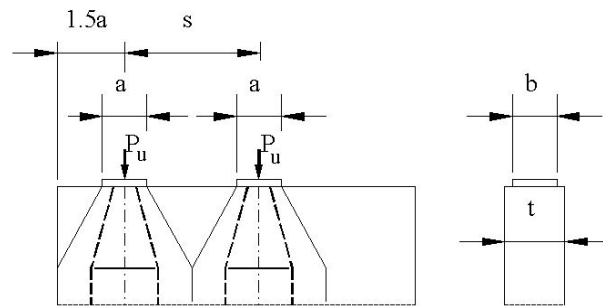

Figure C5.10.9.6.1-2—Edge Distances and Notation

5.10.9.6.2—Compressive Stresses

The concrete compressive stress ahead of the anchorage devices, f_{ca} , calculated using Eq. 5.10.9.6.2-1, shall not exceed the limit specified in Article 5.10.9.3.1:

$$f_{ca} = \frac{0.6P_u \kappa}{A_b \left(1 + \ell_c \left(\frac{1}{b_{eff}} - \frac{1}{t} \right) \right)} \tag{5.10.9.6.2-1}$$

C5.10.9.6.2

This check of concrete compressive stresses is not required for basic anchorage devices satisfying Article 5.10.9.7.2.

Eqs. 5.10.9.6.2-1 and 5.10.9.6.2-2 are based on a strut-and-tie model for a single anchor with the concrete stresses determined as indicated in Figure C5.10.9.6.2-1 (Burdet, 1990), with the anchor plate width, b , and member thickness, t , being equal. Eq. 5.10.9.6.2-1 was modified to include cases with values of $b < t$.

in which:

if $a \leq s < 2a_{eff}$, then :

$$\kappa = 1 + \left(2 - \frac{s}{a_{eff}}\right) \left(0.3 + \frac{n}{15}\right) \quad (5.10.9.6.2-2)$$

if $s \geq 2a_{eff}$, then :

$$\kappa = 1 \quad (5.10.9.6.2-3)$$

where:

- κ = correction factor for closely spaced anchorages
- a_{eff} = lateral dimension of the effective bearing area measured parallel to the larger dimension of the cross-section (in.)
- b_{eff} = lateral dimension of the effective bearing area measured parallel to the smaller dimension of the cross-section (in.)
- P_u = factored tendon force (kip)
- t = member thickness (in.)
- s = center-to-center spacing of anchorages (in.)
- n = number of anchorages in a row
- ℓ_c = longitudinal extent of confining reinforcement of the local zone but not more than the larger of 1.15 a_{eff} or 1.15 b_{eff} (in.)
- A_b = effective bearing area (in.²)

The effective bearing area, A_b , in Eq. 5.10.9.6.2-1 shall be taken as the larger of the anchor bearing plate area; A_{plate} ; or the bearing area of the confined concrete in the local zone, A_{conf} , with the following limitations:

- If A_{plate} controls, A_{plate} shall not be taken larger than $4/\pi A_{conf}$.
- If A_{conf} controls, the maximum dimension of A_{conf} shall not be more than twice the maximum dimension of A_{plate} or three times the minimum dimension of A_{plate} . If any of these limits is violated, the effective bearing area, A_b , shall be based on A_{plate} .
- Deductions shall be made for the area of the duct in the determination of A_b .

If a group of anchorages is closely spaced in two directions, the product of the correction factors, κ , for each direction shall be used, as specified in Eq. 5.10.9.6.2-1.

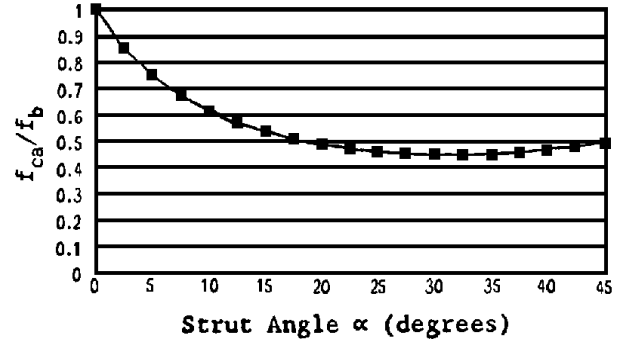
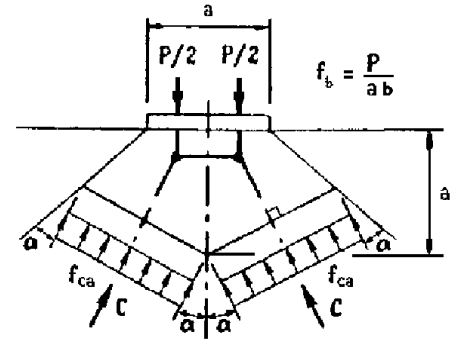

Figure C5.10.9.6.2-1—Local Zone and Strut Interface

For multiple anchorages spaced closer than $2a_{eff}$, a correction factor, κ , is necessary. This factor is based on an assumed stress distribution at a distance of one anchor plate width ahead of the anchorage device, as indicated in Figure C5.10.9.6.2-2.

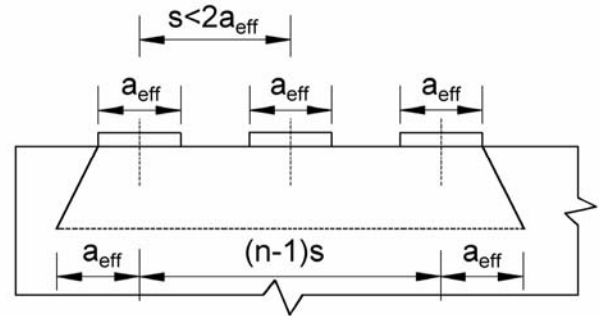

Figure C5.10.9.6.2-2—Closely Spaced Multiple Anchorages

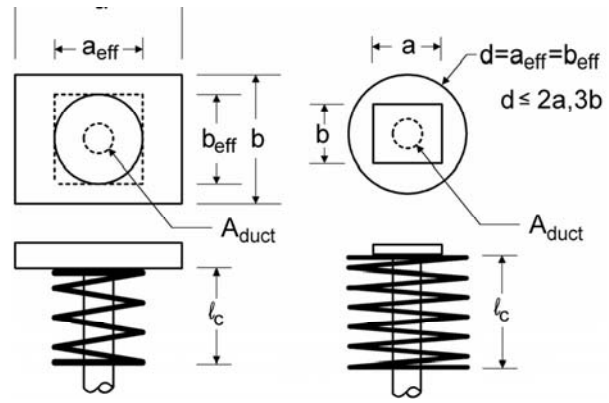

Figure C5.10.9.6.2-3—Effective Bearing Area

5.10.9.6.3—Bursting Forces

The bursting forces in anchorage zones, T_{burst} , may be taken as:

$$T_{burst} = 0.25 \sum P_u \left(1 - \frac{a}{h} \right) + 0.5 |\sum (P_u \sin \alpha)| \tag{5.10.9.6.3-1}$$

The location of the bursting force, d_{burst} , may be taken as:

$$d_{burst} = 0.5 (h - 2e) + 5e \sin \alpha \tag{5.10.9.6.3-2}$$

where:

- T_{burst} = tensile force in the anchorage zone acting ahead of the anchorage device and transverse to the tendon axis (kip)
- P_u = factored tendon force (kip)

C5.10.9.6.3

Eqs. 5.10.9.6.3-1 and 5.10.9.6.3-2 are based on the results of linear elastic stress analyses (Burdet, 1990). Figure C5.10.9.6.3-1 illustrates the terms used in the equations.

- d_{burst} = distance from anchorage device to the centroid of the bursting force, T_{burst} (in.)
- a = lateral dimension of the anchorage device or group of devices in the direction considered (in.)
- e = eccentricity of the anchorage device or group of devices with respect to the centroid of the cross-section; always taken as positive (in.)
- h = lateral dimension of the cross-section in the direction considered (in.)
- α = angle of inclination of a tendon force with respect to the centerline of the member; positive for concentric tendons or if the anchor force points toward the centroid of the section; negative if the anchor force points away from the centroid of the section.

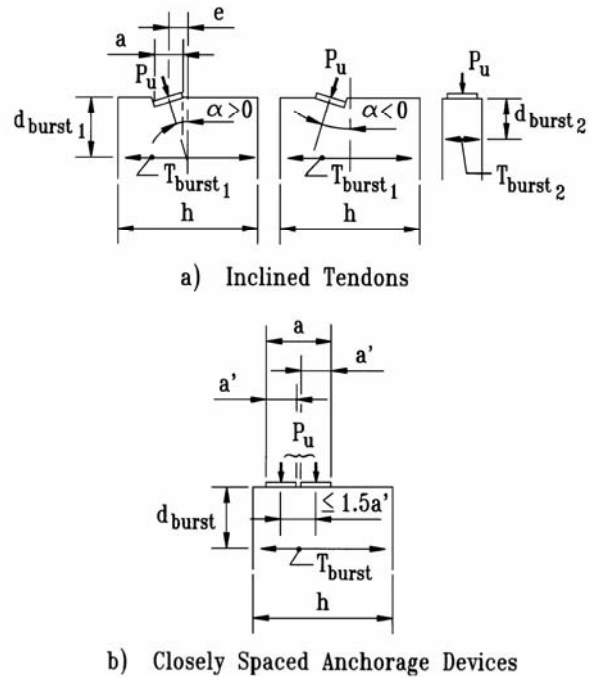

Figure C5.10.9.6.3-1—Notation for Eqs. 5.10.9.6.3-1 and 5.10.9.6.3-2

5.10.9.6.4—Edge Tension Forces

The longitudinal edge tension force may be determined from an analysis of a section located at one-half the depth of the section away from the loaded surface taken as a beam subjected to combined flexure and axial load. The spalling force may be taken as equal to the longitudinal edge tension force but not less than that specified in Article 5.10.9.3.2.

C5.10.9.6.4

If the centroid of all tendons is located outside of the kern of the section, both spalling forces and longitudinal edge tension forces are induced. The determination of the edge tension forces for eccentric anchorages is illustrated in Figure C5.10.9.6.4-1. Either type of axial-flexural beam analysis is acceptable. As in the case for multiple anchorages, this reinforcement is essential for equilibrium of the anchorage zone. It is important to consider stressing sequences that may cause temporary eccentric loadings of the anchorage zone.

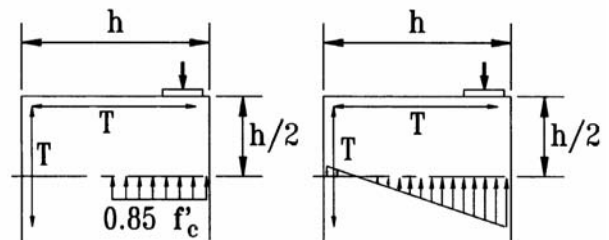

Figure C5.10.9.6.4-1—Determination of Edge Tension Forces for Eccentric Anchorages

5.10.9.7—Design of Local Zones

5.10.9.7.1—Dimensions of Local Zone

Where either:

- The manufacturer has not provided edge distance recommendations, or
- Edge distance have been recommended by the manufacturer, but they have not been independently verified.

The transverse dimensions of the local zone in each direction shall be taken as the greater of:

- The corresponding bearing plate size, plus twice the minimum concrete cover required for the particular application and environment, and
- The outer dimension of any required confining reinforcement, plus the required concrete cover over the confining reinforcing steel for the particular application and environment.

The cover required for corrosion protection shall be as specified in Article 5.12.3.

Where the manufacturer has recommendations for minimum cover, spacing, and edge distances for a particular anchorage device, and where these dimensions have been independently verified, the transverse dimensions of the local zone in each direction shall be taken as the lesser of:

- Twice the edge distance specified by the anchorage device supplier, and
- The center-to-center spacing of anchorages specified by the anchorage device supplier.

Recommendations for spacing and edge distance of anchorages provided by the manufacturer shall be taken as minimum values.

The length of the local zone along the tendon axis shall not be taken to be less than:

- The maximum width of the local zone;
- The length of the anchorage device confining reinforcement; or
- For anchorage devices with multiple bearing surfaces, the distance from the loaded concrete surface to the bottom of each bearing surface, plus the maximum dimension of that bearing surface.

The length of the local zone shall not be taken as greater than 1.5 times the width of the local zone.

C5.10.9.7.1

The provisions of this Article are to ensure adequate concrete strength in the local zone. They are not intended to be guidelines for the design of the actual anchorage hardware.

The local zone is the highly stressed region immediately surrounding the anchorage device. It is convenient to define this region geometrically, rather than by stress levels. Figure C5.10.9.7.1-1 illustrates the local zone.

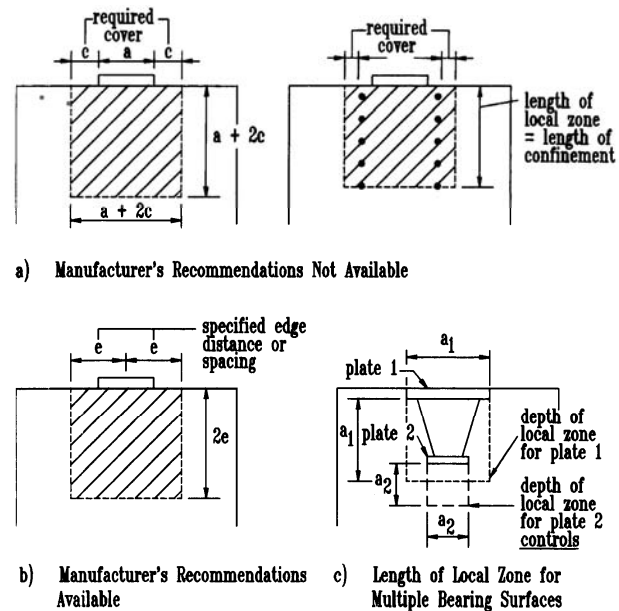

Figure C5.10.9.7.1-1—Geometry of the Local Zone

For closely spaced anchorages, an enlarged local zone enclosing all individual anchorages should also be considered.

5.10.9.7.2—Bearing Resistance

Normal anchorage devices shall comply with the requirements specified herein. Special anchorage devices shall comply with the requirements specified in Article 5.10.9.7.3.

When general zone reinforcement satisfying Article 5.10.9.3.2 is provided, and the extent of the concrete along the tendon axis ahead of the anchorage device is at least twice the length of the local zone as defined in Article 5.10.9.7.1, the factored bearing resistance of anchorages shall be taken as:

$$P_r = \phi f_n A_b \tag{5.10.9.7.2-1}$$

for which f_n is the lesser of:

$$f_n = 0.7 f'_{ci} \sqrt{\frac{A}{A_g}}, \text{ and} \tag{5.10.9.7.2-2}$$

$$f_n = 2.25 f'_{ci} \tag{5.10.9.7.2-3}$$

where:

- ϕ = resistance factor specified in Article 5.5.4.2
- A = maximum area of the portion of the supporting surface that is similar to the loaded area and does not overlap similar areas for adjacent anchorage devices (in.²)
- A_g = gross area of the bearing plate calculated in accordance with the requirements herein (in.²)
- A_b = effective net area of the bearing plate calculated as the area A_g , minus the area of openings in the bearing plate (in.²)
- f'_{ci} = nominal concrete strength at time of application of tendon force (ksi)

The full bearing plate area may be used for A_g and the calculation of A_b if the plate material does not yield at the factored tendon force and the slenderness of the bearing plate, n/t , shall satisfy:

$$n/t \leq 0.08 \left(\frac{E_b}{f_b} \right)^{0.33} \tag{5.10.9.7.2-4}$$

where:

- t = average thickness of the bearing plate (in.)
- E_b = modulus of elasticity of the bearing plate material (ksi)
- f_b = stress in anchor plate at a section taken at the edge of the wedge hole or holes (ksi)
- n = projection of base plate beyond the wedge hole or wedge plate, as appropriate (in.)

C5.10.9.7.2

These Specifications provide bearing pressure limits for anchorage devices, called normal anchorage devices, that are not to be tested in accordance with the acceptance test of Article 10.3.2.3 of *AASHTO LRFD Bridge Construction Specifications*. Alternatively, these limits may be exceeded if an anchorage system passes the acceptance test. Figures C5.10.9.7.2-1, C5.10.9.7.2-2, and C5.10.9.7.2-3 illustrate the specifications of Article 5.10.9.7.2 (Roberts, 1990).

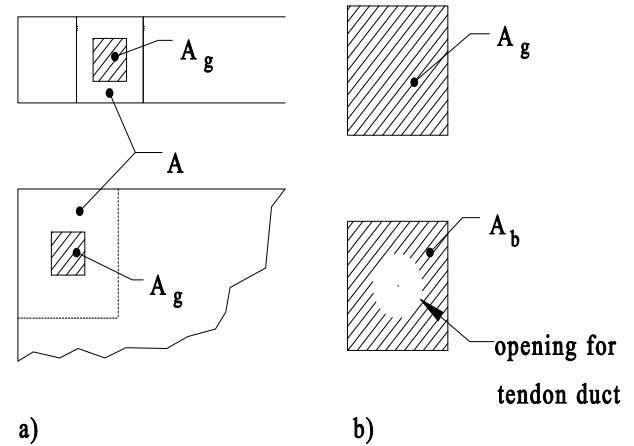

Figure C5.10.9.7.2-1—Area of Supporting Concrete Surface in Eq. 5.10.9.7.2-2

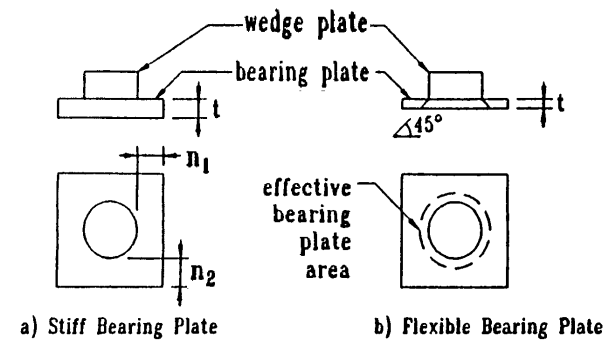

Figure C5.10.9.7.2-2—Effective Bearing Plate Area for Anchorage Devices with Separate Wedge Plate

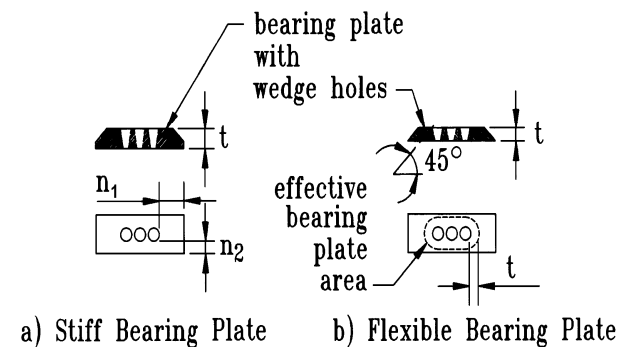

Figure C5.10.9.7.2-3—Effective Bearing Plate Area for Anchorage Device without Separate Wedge Plate

For anchorages with separate wedge plates, n may be taken as the largest distance from the outer edge of the wedge plate to the outer edge of the bearing plate. For rectangular bearing plates, this distance shall be measured parallel to the edges of the bearing plate. If the anchorage has no separate wedge plate, n may be taken as the projection beyond the outer perimeter of the group of holes in the direction under consideration.

For bearing plates that do not meet the slenderness requirement specified herein, the effective gross bearing area, A_g , shall be taken as:

- For anchorages with separate wedge plates:
 - the area geometrically similar to the wedge plate, with dimensions increased by twice the bearing plate thickness,
- For anchorages without separate wedge plates:
 - the area geometrically similar to the outer perimeter of the wedge holes, with dimension increased by twice the bearing plate thickness.

5.10.9.7.3—Special Anchorage Devices

Special anchorage devices that do not satisfy the requirements specified in Article 5.10.9.7.2 may be used, provided that they have been tested by an independent testing agency acceptable to the Engineer and have met the acceptance criteria specified in Articles 10.3.2 and 10.3.2.3.10 of *AASHTO LRFD Bridge Construction Specifications*.

Local anchorage zone reinforcement supplied as part of a proprietary post-tensioning system shall be shown on post-tensioning shop drawings. Adjustment of general anchorage zone tensile reinforcement due to reinforcement supplied as part of a proprietary post-tensioning system may be considered as part of the shop drawing approval process. The responsibility for design of general anchorage zone reinforcement shall remain with the Engineer of Record.

For a series of similar special anchorage devices, tests may only be required for representative samples, unless tests for each capacity of the anchorages in the series are required by the Engineer of Record.

5.10.10—Pretensioned Anchorage Zones

5.10.10.1—Splitting Resistance

The splitting resistance of pretensioned anchorage zones provided by reinforcement in the ends of pretensioned beams shall be taken as:

$$P_r = f_s A_s \quad (5.10.10.1-1)$$

where:

A larger effective bearing area may be calculated by assuming an effective area and checking the new f_b and n/t values.

C5.10.9.7.3

Most anchorage devices fall in this category and still have to pass the acceptance test of Article 10.3.2.3 of *AASHTO LRFD Bridge Construction Specifications*. However, many of the anchorage systems currently available in the United States have passed equivalent acceptance tests. The results of these tests may be considered acceptable if the test procedure is generally similar to that specified in Article 10.3.2.3 of *AASHTO LRFD Bridge Construction Specifications*.

In addition to any required confining reinforcement, the acceptance test of special anchorage devices, supplementary skin reinforcement is permitted by Article 10.3.2.3.4 of *AASHTO LRFD Bridge Construction Specifications*. Equivalent reinforcement should also be placed in the actual structure. Other general zone reinforcement in the corresponding portion of the anchorage zone may be counted toward this reinforcement requirement.

C5.10.10.1

The primary purpose of the choice of the 20-ksi steel stress limit for this provision is crack control.

Splitting resistance is of prime importance in relatively thin portions of pretensioned members that are tall or wide, such as the webs of I-girders and the webs and flanges of box and tub girders. Prestressing steel that is well distributed in such portions will reduce the

- f_s = stress in steel not to exceed 20 ksi
 A_s = total area of reinforcement located within the distance $h/4$ from the end of the beam (in.²)
 h = overall dimension of precast member in the direction in which splitting resistance is being evaluated (in.)

For pretensioned I-girders or bulb tees, A_s shall be taken as the total area of the vertical reinforcement located within a distance of $h/4$ from the end of the member, where h is the overall height of the member (in.).

For pretensioned solid or voided slabs, A_s shall be taken as the total area of the horizontal reinforcement located within a distance of $h/4$ from the end of the member, where h is the overall width of the member (in.).

For pretensioned box or tub girders, A_s shall be taken as the total area of vertical reinforcement or horizontal reinforcement located within a distance $h/4$ from the end of the member, where h is the lesser of the overall width or height of the member (in.).

For pretensioned members with multiple stems A_s shall be taken as the total area of vertical reinforcement, divided evenly among the webs, and located within a distance $h/4$ from the end of each web.

The resistance shall not be less than four percent of the total prestressing force at transfer.

The reinforcement shall be as close to the end of the beam as practicable.

Reinforcement used to satisfy this requirement can also be used to satisfy other design requirements.

splitting forces, while steel that is banded or concentrated at both ends of a member will require increased splitting resistance.

For pretensioned slab members, the width of the member is greater than the depth. A tensile zone is then formed in the horizontal direction perpendicular to the centerline member.

For tub and box girders, prestressing strands are located in both the bottom flange and webs. Tensile zones are then formed in both the vertical and horizontal directions in the webs and flanges. Reinforcement is required in both directions to resist the splitting forces.

Experience has shown that the provisions of this Article generally control cracking in the end regions of pretensioned members satisfactorily; however, more reinforcement than required by this Article may be necessary under certain conditions. Figures C5.10.10.1-1 and C5.10.10.1-2 show examples of splitting reinforcement for tub girders and voided slabs.

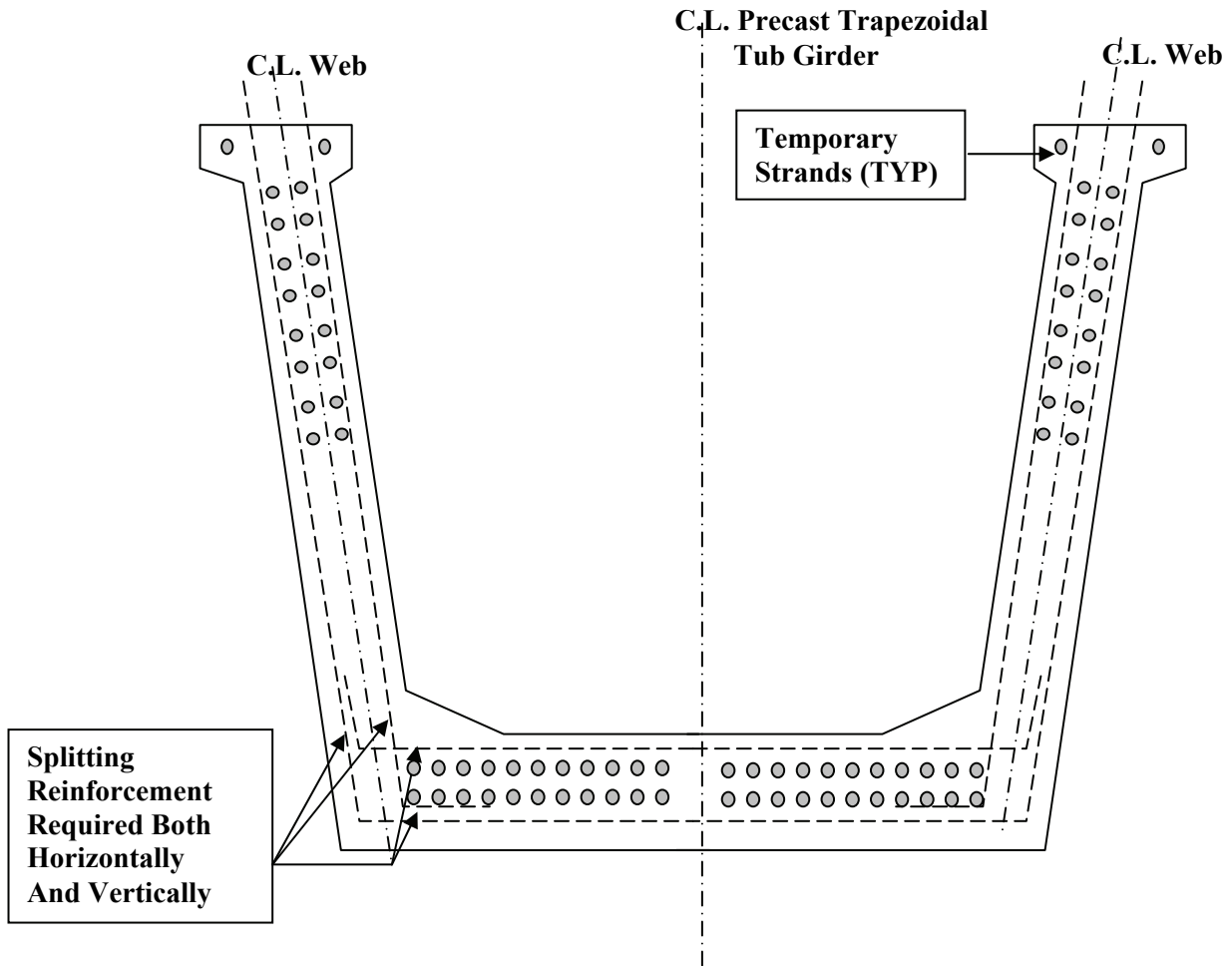

Figure C5.10.10.1-1—Precast Trapezoidal Tub Girder

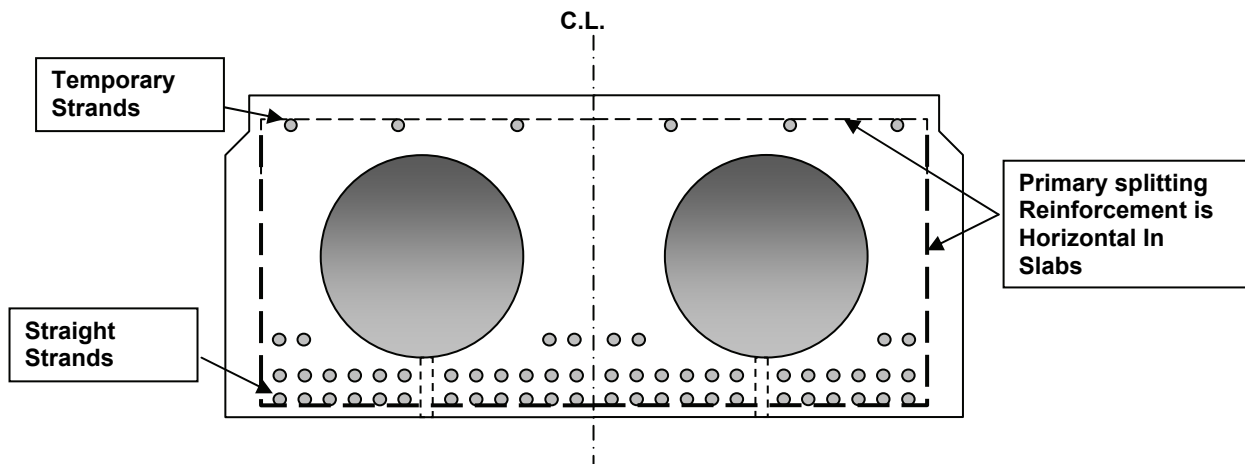

Figure C5.10.10.1-2—Precast Voided Slab

5.10.10.2—Confinement Reinforcement

For the distance of $1.5d$ from the end of the beams other than box beams, reinforcement shall be placed to confine the prestressing steel in the bottom flange. The reinforcement shall not be less than No. 3 deformed bars, with spacing not exceeding 6.0 in. and shaped to enclose the strands.

For box beams, transverse reinforcement shall be provided and anchored by extending the leg of stirrup into the web of the girder.

5.10.11—Provisions for Seismic Design

5.10.11.1—General

The provisions of these Articles shall apply only to the extreme event limit state.

In addition to the other requirements specified in Article 5.10, reinforcing steel shall also conform to the seismic resistance provisions specified herein.

Displacement requirements specified in Article 4.7.4.4 or longitudinal restrainers specified in Article 3.10.9.5 shall apply.

Bridges located in Seismic Zone 2 shall satisfy the requirements in Article 5.10.11.3. Bridges located in Seismic Zones 3 and 4 shall satisfy the requirements specified in Article 5.10.11.4.

C5.10.11.1

These Specifications are based on the work by the Applied Technology Council in 1979–1980. The Loma Prieta earthquake of 1989 provided new insights into the behavior of concrete details under seismic loads. The California Department of Transportation initiated a number of research projects that have produced information that is useful for both the design of new structures and the retrofitting of existing structures. Much of this information has formed the basis of recent provisions published by NCHRP (2002, 2006), MCEER/ATC (2003), and FHWA (2006).

This new information relates to all facets of seismic engineering, including design spectra, analytical techniques, and design details. Bridge designers working in Seismic Zones 2, 3, and 4 are encouraged to avail themselves of current research reports and other literature to augment these Specifications.

The Loma Prieta earthquake confirmed the vulnerability of columns with inadequate core confinement and inadequate anchorage of longitudinal reinforcement. New areas of concern that emerged include:

- Lack of adequate reinforcement for positive moments that may occur in the superstructure over monolithic supports when the structure is subjected to longitudinal dynamic loads;
- Lack of adequate strength in joints between columns and bent caps under transverse dynamic loads; and
- Inadequate reinforcement for torsion, particularly in outrigger-type bent caps.

The purpose of the additional design requirements of this Article is to increase the probability that the design of the components of a bridge are consistent with the overall design philosophy of ATC 6, especially for bridges located in Seismic Zones 2, 3, and 4, and that the potential for failures observed in past earthquakes is minimized. The additional column design requirements of this Article for bridges located in Seismic Zones 2, 3, and 4 are to ensure that a column is provided with reasonable ductility and is forced to yield in flexure and that the potential for a shear, compression, or loss of anchorage mode of failure is minimized. The additional design requirements for piers provide for some inelastic resistance; however, the R-factor specified for piers in Section 4 is to ensure that the anticipated inelastic resistance is significantly less than that of columns.

The actual ductility demand on a column or pier is a complex function of a number of variables, including:

- Earthquake characteristics,
- Design force level,
- Periods of vibration of the bridge,
- Shape of the inelastic hysteresis loop of the columns,
- Elastic damping coefficient,
- Contributions of foundation and soil conditions to structural flexibility, and
- Plastic hinge length of the column.

The damage potential of a column is also related to the ratio of the duration of strong motion shaking to the natural period of vibration of the bridge. This ratio will be an indicator of the number of yield excursions and hence of the cumulative ductility demand.

5.10.11.2—Seismic Zone 1

For bridges in Seismic Zone 1 where the response acceleration coefficient, S_{D1} , specified in Article 3.10.4.2, is less than 0.10, no consideration of seismic forces shall be required for the design of structural components, except that the design of the connection of the superstructure to the substructure shall be as specified in Article 3.10.9.2.

For bridges in Seismic Zone 1 where the response acceleration coefficient, S_{D1} , is greater than or equal to 0.10 but less than or equal to 0.15, no consideration of seismic forces shall be required for the design of structural components, except that:

- The design of the connection of the superstructure to the substructure shall be as specified in Article 3.10.9.2.
- The transverse reinforcement requirements at the top and bottom of a column shall be as specified in Articles 5.10.11.4.1d and 5.10.11.4.1e.

5.10.11.3—Seismic Zone 2

The requirements of Article 5.10.11.4 shall be taken to apply to bridges in Seismic Zone 2 except that the area of longitudinal reinforcement shall not be less than 0.01 or more than 0.06 times the gross cross-section area, A_g .

C5.10.11.2

These requirements for Zone 1 are a departure from those in the previous edition of these Specifications. These changes are necessary because the return period of the design event has been increased from 500 to 1000 years, and the Zone Boundaries (Table 3.10.6-1) have been increased accordingly. The high end of the new Zone 1 ($0.10 < S_{D1} < 0.15$) overlaps with the low end of the previous Zone 2. Since performance expectations have not changed with increasing return period, the minimum requirements for bridges in the high end of Zone 1 should therefore be the same as those for the previous Zone 2. Requirements for the remainder of Zone 1 ($S_{D1} < 0.10$) are unchanged.

C5.10.11.3

Bridges in Seismic Zone 2 have a reasonable probability of being subjected to seismic forces that will cause yielding of the columns. Thus, it is deemed necessary that columns have some ductility capacity, although it is recognized that the ductility demand will not be as great as for columns of bridges in Seismic Zones 3 and 4. Nevertheless, all of the requirements for Zones 3 and 4 shall apply to bridges in Zone 2, with exception of the upper limit on reinforcing steel. This is a departure from the requirements in the previous edition of these Specifications,

5.10.11.4—Seismic Zones 3 and 4

5.10.11.4.1—Column Requirements

For the purpose of this Article, a vertical support shall be considered to be a column if the ratio of the clear height to the maximum plan dimensions of the support is not less than 2.5. For a flared column, the maximum plan dimension shall be taken at the minimum section of the flare. For supports with a ratio less than 2.5, the provisions for piers of Article 5.10.11.4.2 shall apply.

A pier may be designed as a pier in its strong direction and a column in its weak direction.

5.10.11.4.1a—Longitudinal Reinforcement

The area of longitudinal reinforcement shall not be less than 0.01 or more than 0.04 times the gross cross-section area A_g .

5.10.11.4.1b—Flexural Resistance

The biaxial strength of columns shall not be less than that required for flexure, as specified in Article 3.10.9.4. The column shall be investigated for both extreme load cases, as specified in Article 3.10.8, at the extreme event limit state. The resistance factors of Article 5.5.4.2 shall be replaced for columns with either spiral or tie reinforcement by the value of 0.9.

in which selected requirements in Zones 3 and 4 were required for Zone 2. Satisfying all of the requirements, with one exception, is deemed necessary because the upper boundary for Zone 2 in the current edition is significantly higher than in the previous edition due to the increase in the return period for the design earthquake from 500 to 1000 yr.

C5.10.11.4.1

The definition of a column in this Article is provided as a guideline to differentiate between the additional design requirements for a wall-type pier and the requirements for a column. If a column or pier is above or below the recommended criterion, it may be considered to be a column or a pier, provided that the appropriate R-Factor of Article 3.10.7.1 and the appropriate requirements of either Articles 5.10.11.4.1 or 5.10.11.4.2 are used. For columns with an aspect ratio less than 2.5, the forces resulting from plastic hinging will generally exceed the elastic design forces; consequently, the forces of Article 5.10.11.4.2 would not be applicable.

C5.10.11.4.1a

This requirement is intended to apply to the full section of the columns. The lower limit on the column reinforcement reflects the traditional concern for the effect of time-dependent deformations as well as the desire to avoid a sizable difference between the flexural cracking and yield moments. Columns with less than one percent steel have also not exhibited good ductility (Halvorsen, 1987). The four percent maximum ratio is to avoid congestion and extensive shrinkage cracking and to permit anchorage of the longitudinal steel. The previous edition of these Specifications limited this ratio to six percent but this cap is lowered in the current edition because the boundaries for Zones 3 and 4 are significantly higher than in the previous edition, due to the increase in the return period for the design earthquake from 500 to 1000 years. The four percent figure is consistent with that recommended in recent publications by NCHRP (2002, 2006) and MCEER/ATC (2003).

C5.10.11.4.1b

Columns are required to be designed biaxially and to be investigated for both the minimum and maximum axial forces. The previous edition of these Specifications reduced the flexural resistance factor from 0.9 to 0.5 as the axial load increased from 0 to $0.20 f'_c A_g$, because of the trend toward a reduction in ductility capacity as the axial load increases. This requirement is relaxed in this edition but a $P-\Delta$ requirement has been added (Article 4.7.4.5) to limit the demand on ductility

5.10.11.4.1c—Column Shear and Transverse Reinforcement

The factored shear force V_u on each principal axis of each column and pile bent shall be as specified in Article 3.10.9.4.

The amount of transverse reinforcement shall not be less than that specified in Article 5.8.3.

The following provisions apply to the end regions of the top and bottom of the column and pile bents:

- In the end regions, V_c shall be taken as that specified in Article 5.8.3, provided that the minimum factored axial compression force exceeds $0.10f'_cA_g$. For compression forces less than $0.10f'_cA_g$, V_c shall be taken to decrease linearly from the value given in Article 5.8.3 to zero at zero compression force.
- The end region shall be assumed to extend from the soffit of girders or cap beams at the top of columns or from the top of foundations at the bottom of columns, a distance taken as the greater of:
 - The maximum cross-sectional dimension of the column,
 - One-sixth of the clear height of the column, or
 - 18.0 in.
- The end region at the top of the pile bent shall be taken as that specified for columns. At the bottom of the pile bent, the end region shall be considered to extend from three pile diameters below the calculated point of maximum moment to one pile diameter but shall not extend less than 18.0 in. above the mud line.

capacity due to excessive deflection. Also, the R-factors have been maintained at their previous levels (Article 3.10.7) even though the return period of the design earthquake has been increased from 500 to 1,000 years. In both the NCHRP 12-49 and 20-7(193) provisions, the recommended flexural resistance factor is 1.0. However, since the current Specifications are force-based and do not explicitly calculate the ductility demand as in both 12-49 and 20-7(193) provisions, limiting the factor to 0.9 is considered justified in lieu of a more rigorous analysis.

C5.10.11.4.1c

Seismic hoops may offer the following advantages over spirals:

- Improved constructability when the transverse reinforcement cage must extend up into a bent cap or down into a footing. Seismic hoops can be used at the top and bottom of the column in combination with spirals, or full height of the column in place of spirals.
- Ability to sample and perform destructive testing of in-situ splices prior to assembly.
- Breakage at a single location vs. potential unwinding and plastic hinge failure.

The requirements of this Article are intended to minimize the potential for a column shear failure. The design shear force is specified as that capable of being developed by either flexural yielding of the columns or the elastic design shear force. This requirement was added because of the potential for superstructure collapse if a column fails in shear.

A column may yield in either the longitudinal or transverse direction. The shear force corresponding to the maximum shear developed in either direction for noncircular columns should be used for the determination of the transverse reinforcement.

The concrete contribution to shear resistance is undependable within the plastic hinge zone, particularly at low axial load levels, because of full-section cracking under load reversals. As a result, the concrete shear contribution should be reduced for axial load levels less than $0.10f'_cA_g$.

For a noncircular pile, this provision may be applied by substituting the larger cross-sectional dimension for the diameter.

5.10.11.4.1d—Transverse Reinforcement for Confinement at Plastic Hinges

The cores of columns and pile bents shall be confined by transverse reinforcement in the expected plastic hinge regions. The transverse reinforcement for confinement shall have a yield strength not more than that of the longitudinal reinforcement, and the spacing shall be taken as specified in Article 5.10.11.4.1e.

For a circular column, the volumetric ratio of spiral or seismic hoop reinforcement, ρ_s , shall satisfy either that required in Article 5.7.4.6 or:

$$\rho_s \geq 0.12 \frac{f'_c}{f_y} \quad (5.10.11.4.1d-1)$$

where:

- f'_c = specified compressive strength of concrete at 28 days, unless another age is specified (ksi)
 f_y = yield strength of reinforcing bars (ksi)

Within plastic hinge zones, splices in spiral reinforcement shall be made by full-welded splices or by full-mechanical connections.

For a rectangular column, the total gross sectional area, A_{sh} , of rectangular hoop reinforcement shall satisfy either:

$$A_{sh} \geq 0.30 sh_c \frac{f'_c}{f_y} \left[\frac{A_g}{A_c} - 1 \right] \quad (5.10.11.4.1d-2)$$

or

$$A_{sh} \geq 0.12 sh_c \frac{f'_c}{f_y} \quad (5.10.11.4.1d-3)$$

where:

- s = vertical spacing of hoops, not exceeding 4.0 in. (in.)
 A_c = area of column core (in.²)
 A_g = gross area of column (in.²)

C5.10.11.4.1d

Plastic hinge regions are generally located at the top and bottom of columns and pile bents. The largest of either these requirements or those of Article 5.10.11.4.1c should govern; these requirements are not in addition to those of Article 5.10.11.4.1c.

The main function of the transverse reinforcement specified in this Article is to ensure that the axial load carried by the column after spalling of the concrete cover will at least equal the load carried before spalling and to ensure that buckling of the longitudinal reinforcement is prevented. Thus, the spacing of the confining reinforcement is also important.

Careful detailing of the confining steel in the plastic hinge zone is required because of spalling and loss of concrete cover. With deformation associated with plastic hinging, the strains in the transverse reinforcement increase. Ultimate-level splices are required. Similarly, rectangular hoops should be anchored by bending ends back into the core.

Figures C5.10.11.4.1d-2 and C5.10.11.4.1d-4 illustrate the use of Eqs. 5.10.11.4.1d-2 and 5.10.11.4.1d-3. The required total area of hoop reinforcement should be determined for both principal axes of a rectangular or oblong column. Figure C5.10.11.4.1d-4 shows the distance to be utilized for h_c and the direction of the corresponding reinforcement for both principal directions of a rectangular column.

While these Specifications allow the use of either spirals or ties for transverse column reinforcement, the use of spirals is recommended as the more effective and economical solution. Where more than one spiral cage is used to confine an oblong column core, the spirals should be interlocked with longitudinal bars as shown in Figure C5.10.11.4.1d-3. Spacing of longitudinal bars of a maximum of 8.0 in. center-to-center is also recommended to help confine the column core.

Examples of transverse column reinforcement are shown herein.

A_{sh} = total cross-sectional area of tie reinforcement, including supplementary cross-ties having a vertical spacing of s and crossing a section having a core dimension of h_c (in.²)

f_y = yield strength of tie or spiral reinforcement (ksi)

h_c = core dimension of tied column in the direction under consideration (in.)

A_{sh} shall be determined for both principal axes of a rectangular column.

Transverse hoop reinforcement may be provided by single or overlapping hoops. Cross-ties having the same bar size as the hoop may be used. Each end of the cross-tie shall engage a peripheral longitudinal reinforcing bar. All cross-ties shall have seismic hooks as specified in Article 5.10.2.2.

Transverse reinforcement meeting the following requirements shall be considered to be a cross-tie:

- The bar shall be a continuous bar having a hook of not less than 135 degrees, with an extension of not less than six diameters but not less than 3.0 in at one end and a hook of not less than 90 degrees with an extension of not less than six diameters at the other end.
- The hooks shall engage peripheral longitudinal bars.
- The 90-degree hooks of two successive cross-ties engaging the same longitudinal bars shall be alternated end-for-end.

Transverse reinforcement meeting the following requirements shall be considered to be a hoop:

- The bar shall be closed tie or continuously wound tie.
- A closed tie may be made up of several reinforcing elements with 135-degree hooks having a six- diameter but not less than a 3.0-in. extension at each end.
- A continuously wound tie shall have at each end a 135-degree hook with a six diameter but not less than a 3.0 in. extension that engages the longitudinal reinforcement.

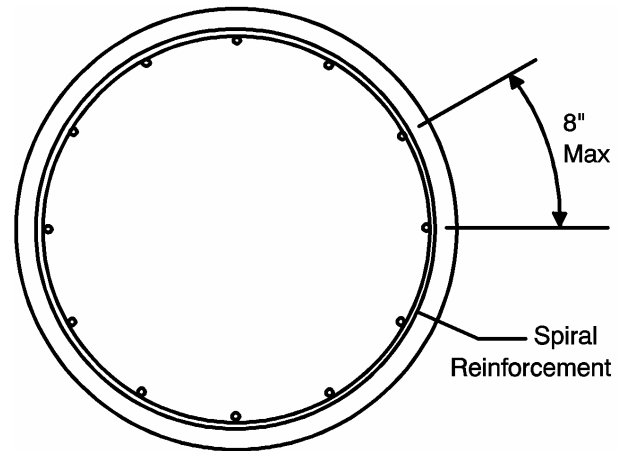

Figure C5.10.11.4.1d-1—Single Spiral

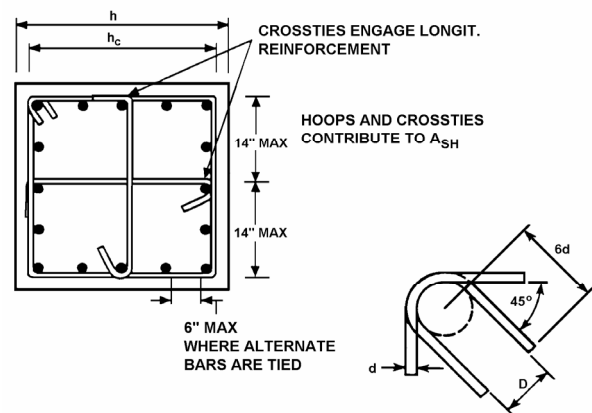

Figure C5.10.11.4.1d-2—Column Tie Details

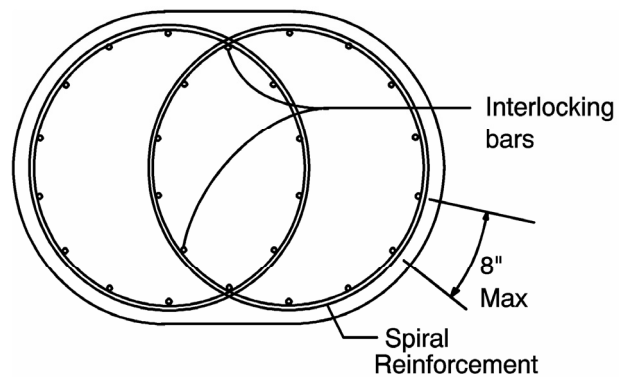

Figure C5.10.11.4.1d-3—Column Interlocking Spiral Details

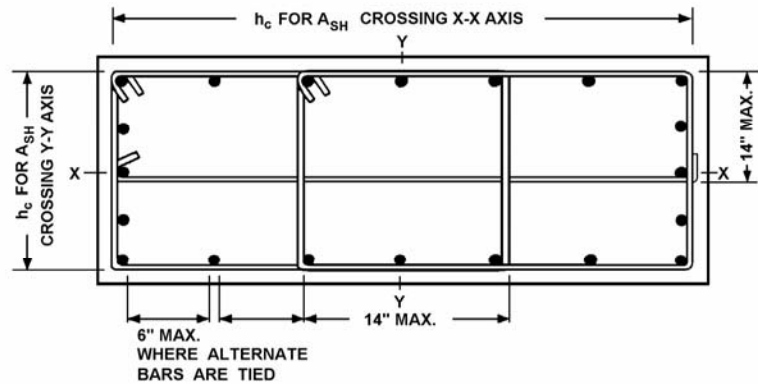

Figure C5.10.11.4.1d-4—Column Tie Details

5.10.11.4.1e—Spacing of Transverse Reinforcement for Confinement

Transverse reinforcement for confinement shall be:

- Provided at the top and bottom of the column over a length not less than the greatest of the maximum cross-sectional column dimensions, one-sixth of the clear height of the column, or 18.0 in.;
- Extended into the top and bottom connections as specified in Article 5.10.11.4.3;
- Provided at the top of piles in pile bents over the same length as specified for columns;
- Provided within piles in pile bents over a length extending from 3.0 times the maximum cross-sectional dimension below the calculated point of moment fixity to a distance not less than the maximum cross-sectional dimension or 18.0 in. above the mud line; and
- Spaced not to exceed one-quarter of the minimum member dimension or 4.0 in. center-to-center.

5.10.11.4.1f—Splices

The provisions of Article 5.11.5 shall apply for the design of splices.

Lap splices in longitudinal reinforcement shall not be used.

The spacing of the transverse reinforcement over the length of the splice shall not exceed 4.0 in. or one-quarter of the minimum member dimension.

Full-welded or full-mechanical connection splices conforming to Article 5.11.5 may be used, provided that not more than alternate bars in each layer of longitudinal reinforcement are spliced at a section, and the distance between splices of adjacent bars is greater than 24.0 in. measured along the longitudinal axis of the column.

C5.10.11.4.1f

It is often desirable to lap longitudinal reinforcement with dowels at the column base. This is undesirable for seismic performance because:

- The splice occurs in a potential plastic hinge region where requirements for bond is critical, and
- Lapping the main reinforcement will tend to concentrate plastic deformation close to the base and reduce the effective plastic hinge length as a result of stiffening of the column over the lapping region. This may result in a severe local curvature demand.

Splices in seismic-critical elements should be designed for ultimate behavior under seismic deformation demands. Recommendations for acceptable strains are

provided in Table C5.10.11.4.1f-1. The strain demand at a cross-section is obtained from the deformation demand at that cross-section and the corresponding moment-curvature relationship. Traditional service level splices are only appropriate in components such as bent caps, girders, and footings, when not subjected to or protected from seismic damage by careful location and detailing of plastic hinge regions.

Table C5.10.11.4.1f-1—Recommended Strain Limits in A706/A706M Bars, and Bars with Splices for Seismic Zones 3 and 4

	Minimum Required Resisting Strain, ϵ Bar only	Minimum Required Resisting Strain, ϵ Bar with Splice	Maximum Allowable Load Strain, ϵ	Resulting Factor of Safety
Ultimate	6% for #11 and larger 9% for #10 and smaller	6% for #11 and larger 9% for #10 and smaller	<2%	3 to 4.5
Service	(same as above)	>2 %	<0.2%	>10
Lap (or welded / mechanical lap in lieu of lap splice)	(same as above)	>0.2%	<0.15% (unfactored loads) <0.2% (factored loads)	1.33

Limits are based on tests done by the California Department of Transportation and University of California-Berkeley, the latter of which is described in ACI (2001). The demonstrated strain at ultimate resistance of butt-welded details was divided by the typical demand strain in order to document the factor of safety. Although current experimental limitations of other splice details performing at the service level preclude strain measurements, known values are shown in Table C5.10.11.4.1f-1 for comparison. The variability of strain along the potential plastic hinge justifies the much higher factor of safety. Use of

traditional splice details to resist extreme loading conditions where nonlinear behavior is desired and analyzed as such, are shown to be inefficient. ASTM A615/A615M steel is generally not permitted by Caltrans because of weldability and ductility concerns, and was not investigated.

5.10.11.4.2—Requirements for Wall-Type Piers

The provisions herein specified shall apply to the design for the strong direction of a pier. The weak direction of a pier may be designed as a column conforming to the provisions of Article 5.10.11.4.1, with the response modification factor for columns used to determine the design forces. If the pier is not designed as a column in its weak direction, the limitations for factored shear resistance herein specified shall apply.

The minimum reinforcement ratio, both horizontally, ρ_h , and vertically, ρ_v , in any pier shall not be less than 0.0025. The vertical reinforcement ratio shall not be less than the horizontal reinforcement ratio.

C5.10.11.4.2

The requirements of this Article are based on limited data available on the behavior of piers in the inelastic range. Consequently, the R-Factor of 2.0 for piers is based on the assumption of minimal inelastic behavior.

Reinforcement spacing, either horizontally or vertically, shall not exceed 18.0 in. The reinforcement required for shear shall be continuous and shall be distributed uniformly.

The factored shear resistance, V_r , in the pier shall be taken as the lesser of:

$$V_r = 0.253\sqrt{f'_c}bd, \text{ and} \quad (5.10.11.4.2-1)$$

$$V_r = \phi V_n \quad (5.10.11.4.2-2)$$

in which:

$$V_n = \left[0.063\sqrt{f'_c} + \rho_n f_y \right] bd \quad (5.10.11.4.2-3)$$

Horizontal and vertical layers of reinforcement should be provided on each face of a pier. Splices in horizontal pier reinforcement shall be staggered, and splices in the two layers shall not occur at the same location.

5.10.11.4.3—Column Connections

The design force for the connection between the column and the cap beam superstructure, pile cap, or spread footing shall be as specified in Article 3.10.9.4.3. The development length for all longitudinal steel shall be 1.25 times that required for the full yield strength of reinforcing as specified in Article 5.11.

Column transverse reinforcement, as specified in Article 5.10.11.4.1d, shall be continued for a distance not less than one-half the maximum column dimension or 15.0 in. from the face of the column connection into the adjoining member.

The nominal shear resistance, V_n , provided by the concrete in the joint of a frame or bent in the direction under consideration, shall satisfy:

- For normal weight aggregate concrete:

$$V_n \leq 0.380 bd\sqrt{f'_c}, \text{ and} \quad (5.10.11.4.3-1)$$

- For lightweight aggregate concrete:

$$V_n \leq 0.285 bd\sqrt{f'_c} \quad (5.10.11.4.3-2)$$

5.10.11.4.4—Construction Joints in Piers and Columns

Where shear is resisted at a construction joint solely by dowel action and friction on a roughened concrete surface, the nominal shear resistance across the joint, V_n , shall be taken as:

$$V_n = (A_v f_y + 0.75P_u) \quad (5.10.11.4.4-1)$$

The requirement that $\rho_v \geq \rho_n$ is intended to avoid the possibility of inadequate web reinforcements in piers, which are short in comparison to their height. Splices should be staggered in an effort to avoid weak sections.

The requirement for a minimum of two layers of reinforcement in walls carrying substantial design shears is based on the premise that two layers of reinforcement will tend to “basket” the concrete and retain the integrity of the wall after cracking of the concrete.

C5.10.11.4.3

A column connection, as referred to in this Article, is the vertical extension of the column area into the adjoining member.

The integrity of the column connection is important if the columns are to develop their flexural capacity. The longitudinal reinforcement should be capable of developing its overstrength capacity of $1.25f_y$. The transverse confining reinforcement of the column should be continued a distance into the joint to avoid a plane of weakness at the interface.

The strength of the column connections in a column cap is relatively insensitive to the amount of transverse reinforcement, provided that there is a minimum amount and that shear resistance is limited to the values specified. The factored shear resistance for joints made with lightweight aggregate concrete has been based on the observation that shear transfer in such concrete has been measured to be approximately 75 percent of that in normal weight aggregate concrete.

C5.10.11.4.4

Eq. 5.10.11.4.4-1 is based on Eq. 11-26 of ACI 318-89 but is restated to reflect dowel action and frictional resistance.

where:

A_{vf} = the total area of reinforcement, including flexural reinforcement (in.²)

P_u = the minimum factored axial load as specified in Article 3.10.9.4 for columns and piers (kip)

5.10.12—Reinforcement for Hollow Rectangular Compression Members

5.10.12.1—General

The area of longitudinal reinforcement in the cross-section shall not be less than 0.01 times the gross area of concrete.

Two layers of reinforcement shall be provided in each wall of the cross-section, one layer near each face of the wall. The areas of reinforcement in the two layers shall be approximately equal.

5.10.12.2—Spacing of Reinforcement

The center-to-center lateral spacing of longitudinal reinforcing bars shall be no greater than the lesser of 1.5 times the wall thickness or 18.0 in.

The center-to-center longitudinal spacing of lateral reinforcing bars shall be no greater than the lesser of 1.25 times the wall thickness or 12.0 in.

5.10.12.3—Ties

Cross-ties shall be provided between layers of reinforcement in each wall. The cross-ties shall include a standard 135-degree hook at one end and a standard 90-degree hook at the other end. Cross-ties shall be located at bar grid intersections, and the hooks of all ties shall enclose both lateral and longitudinal bars at the intersections. Each longitudinal reinforcing bar and each lateral reinforcing bar shall be enclosed by the hook of a cross-tie at a spacing no greater than 24.0 in.

For segmentally constructed members, additional cross-ties shall be provided along the top and bottom edges of each segment. The cross-tie shall be placed so as to link the ends of each pair of internal and external longitudinal reinforcing bars in the walls of the cross-section.

5.10.12.4—Splices

Lateral reinforcing bars may be joined at the corners of the cross-section by overlapping 90-degree bends. Straight lap splices of lateral reinforcing bars shall not be permitted unless the overlapping bars are enclosed over the length of the splice by the hooks of at least four cross-ties located at intersections of the lateral bars and longitudinal bars.

5.10.12.5—Hoops

Where details permit, the longitudinal reinforcing bars in the corners of the cross-section shall be enclosed by closed hoops. If closed hoops cannot be provided, pairs of U-shaped bars with legs at least twice as long as the wall thickness and oriented 90 degrees to one another may be used.

Post-tensioning ducts located in the corners of the cross-section shall be anchored into the corner regions with closed hoops or stirrups having a 90-degree bend at each end to enclose at least one longitudinal bar near the outer face of the cross-section.

5.11—DEVELOPMENT AND SPLICES OF REINFORCEMENT**5.11.1—General****5.11.1.1—Basic Requirements**

The calculated force effects in the reinforcement at each section shall be developed on each side of that section by embedment length, hook, mechanical device, or a combination thereof. Hooks and mechanical anchorages may be used in developing bars in tension only.

5.11.1.2—Flexural Reinforcement*5.11.1.2.1—General*

Critical sections for development of reinforcement in flexural members shall be taken at points of maximum stress and at points within the span where adjacent reinforcement terminates or is bent.

Except at supports of simple spans and at the free ends of cantilevers, reinforcement shall be extended beyond the point at which it is no longer required to resist flexure for a distance not less than:

- The effective depth of the member,
- 15 times the nominal diameter of bar, or
- 1/20 of the clear span.

Continuing reinforcement shall extend not less than the development length, ℓ_d , specified in Article 5.11.2, beyond the point where bent or terminated tension reinforcement is no longer required to resist flexure.

No more than 50 percent of the reinforcement shall be terminated at any section, and adjacent bars shall not be terminated in the same section.

Tension reinforcement may also be developed by either bending across the web in which it lies and terminating it in a compression area and providing the

C5.11.1.1

Most of the provisions in this Article are based on ACI 318-89 and its attendant commentary.

C5.11.1.2.1

As a maximum, every other bar in a section may be terminated.

Past editions of the Standard Specifications required that flexural reinforcement not be terminated in a tension zone, unless one of the following conditions was satisfied:

development length ℓ_d to the design section, or by making it continuous with the reinforcement on the opposite face of the member.

- The factored shear force at the cutoff point did not exceed two-thirds of the factored shear resistance, including the shear strength provided by the shear reinforcement.
- Stirrup area in excess of that required for shear and torsion was provided along each terminated bar over a distance from the termination point not less than three-fourths the effective depth of the member. The excess stirrup area, A_v , was not less than $0.06 b_w s / f_y$. Spacing, s , did not exceed $0.125d / \beta_b$, where β_b was the ratio of the area of reinforcement cut off to the total area of tension reinforcement at the section.
- For No. 11 bars and smaller, the continuing bars provided double the area required for flexure at the cutoff point, and the factored shear force did not exceed three-fourths of the factored shear resistance.

These provisions are now supplemented by the provisions of Article 5.8, which account for the need to provide longitudinal reinforcement to react the horizontal component of inclined compression diagonals that contribute to shear resistance.

Supplementary anchorages may take the form of hooks or welding to anchor bars.

Supplementary anchorages shall be provided for tension reinforcement in flexural members where the reinforcement force is not directly proportional to factored moment as follows:

- Sloped, stepped or tapered footings,
- Brackets,
- Deep flexural members, or
- Members in which tension reinforcement is not parallel to the compression face.

5.11.1.2.2—Positive Moment Reinforcement

At least one-third the positive moment reinforcement in simple span members and one-fourth the positive moment reinforcement in continuous members shall extend along the same face of the member beyond the centerline of the support. In beams, such extension shall not be less than 6.0 in.

C5.11.1.2.2

Past editions of the Standard Specifications required that at end supports and at points of inflection, positive moment tension reinforcement be limited to a diameter such that the development length, ℓ_d , determined for f_y by Article 5.11.2.1, satisfied Eq. C5.11.1.2.2-1:

$$\ell_d \leq \frac{M_n}{V_u} + \ell_a \quad (\text{C5.11.1.2.2-1})$$

where:

- M_n = nominal flexural strength, assuming all positive moment tension reinforcement at the section to be stressed to the specified yield strength f_y (kip-in.)
- V_u = factored shear force at the section (kip)
- ℓ_a = the embedment length beyond the center of a support or at a point of inflection; taken as the greater of the effective depth of the member and $12.0 d_b$ (in.)

Eq. C5.11.1.2.2-1 does not have to be satisfied for reinforcement terminating beyond the centerline of end supports by either a standard hook or a mechanical anchorage at least equivalent to a standard hook.

The value M_n/V_u in Eq. C5.11.1.2.2-1 was to be increased by 30 percent for the ends of the reinforcement located in an area where a reaction applies transverse compression to the face of the beam under consideration.

The intent of the 30 percent provision is illustrated in Figure C5.11.1.2.2-1.

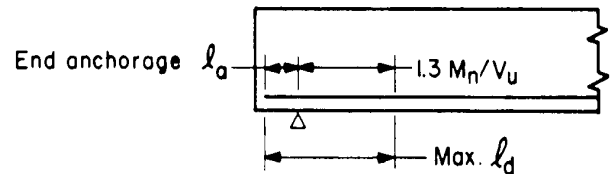

Note: The 1.3 factor is usable only if the reaction confines the ends of the reinforcement.

Figure C5.11.1.2.2-1—End Confinement

These provisions are now supplemented by the provisions of Article 5.8, which account for the need to provide longitudinal reinforcement to react the horizontal component of inclined compression diagonals that contribute to shear resistance.

Reinforcement with specified yield strengths in excess of 75.0 ksi may require longer extensions than required by this Article.

5.11.1.2.3—Negative Moment Reinforcement

At least one-third of the total tension reinforcement provided for negative moment at a support shall have an embedment length beyond the point of inflection not less than:

- The effective depth of the member,
- 12.0 times the nominal diameter of bar, and
- 0.0625 times the clear span.

5.11.1.2.4—Moment Resisting Joints

Flexural reinforcement in continuous, restrained, or cantilever members or in any member of a rigid frame shall be detailed to provide continuity of reinforcement at intersections with other members to develop the nominal moment resistance of the joint.

In Seismic Zones 3 and 4, joints shall be detailed to resist moments and shears resulting from horizontal loads through the joint.

C5.11.1.2.4

Reinforcing details for developing continuity through joints are suggested in the ACI Detailing Manual.

As of this writing (*Fall 1997*), much research on moment resisting joints and especially on the seismic response thereof is in progress. The reports on this work should be consulted as they become available.

5.11.2—Development of Reinforcement

For reinforcement conforming to the requirements of ASTM A1035/A1035M, the value of f_y used in this Article shall be taken as 100 ksi.

C5.11.2

Although the specified yield strength of reinforcing bars used in design shall not exceed 75.0 ksi, tests have shown that a longer development length is needed with reinforcement conforming to ASTM A1035/A1035M to achieve a ductility comparable to that achieved with reinforcement conforming to AASHTO M 31. Limited tests have shown a lack of ductility in tension splices of reinforcement conforming to ASTM A1035 when compared to the behavior of splices with reinforcement conforming to AASHTO M 31, when the splice length is calculated using the maximum design yield strength of 75.0 ksi. However, when the splice length of the ASTM A1035/A1035M reinforcement is determined using its specified minimum yield strength of 100 ksi, more ductility is achieved. Consequently, it is proposed to use 100 ksi until additional research indicates an alternative value.

5.11.2.1—Deformed Bars and Deformed Wire in Tension

5.11.2.1.1—Tension Development Length

The tension development length, ℓ_d , shall not be less than the product of the basic tension development length, ℓ_{db} , specified herein and the modification factor or factors specified in Articles 5.11.2.1.2 and 5.11.2.1.3. The tension development length shall not be less than 12.0 in., except for lap splices specified in Article 5.11.5.3.1 and development of shear reinforcement specified in Article 5.11.2.6.

The basic tension development length, ℓ_{db} , in in. shall be taken as:

- For No. 11 bar and smaller $\frac{1.25 A_b f_y}{\sqrt{f'_c}}$
 but not less than $0.4 d_b f_y$
- For No. 14 bars $\frac{2.70 f_y}{\sqrt{f'_c}}$
- For No. 18 bars $\frac{3.5 f_y}{\sqrt{f'_c}}$
- For deformed wire $\frac{0.95 d_b f_y}{\sqrt{f'_c}}$

where:

- A_b = area of bar or wire (in.²)
- f_y = specified yield strength of reinforcing bars (ksi)
- f'_c = specified compressive strength of concrete at 28 days, unless another age is specified (ksi)
- d_b = diameter of bar or wire (in.)

5.11.2.1.2—Modification Factors which Increase ℓ_d

The basic development length, ℓ_{db} , shall be multiplied by the following factor or factors, as applicable:

- For top horizontal or nearly horizontal reinforcement, so placed that more than 12.0 in. of fresh concrete is cast below the reinforcement..... 1.4
- For lightweight aggregate concrete where f_{ct} (ksi) is specified..... $\frac{0.22\sqrt{f'_c}}{f_{ct}} \geq 1.0$
- For all-lightweight concrete where f_{ct} is not specified..... 1.3
- For sand-lightweight concrete where f_{ct} is not specified..... 1.2

Linear interpolation may be used between all-lightweight and sand-lightweight provisions when partial sand replacement is used.

- For epoxy-coated bars with cover less than $3d_b$ or with clear spacing between bars less than $6d_b$ 1.5
- For epoxy-coated bars not covered above..... 1.2

The product obtained when combining the factor for top reinforcement with the applicable factor for epoxy-coated bars need not be taken to be greater than 1.7.

5.11.2.1.3—Modification Factors which Decrease ℓ_d

The basic development length, ℓ_{db} , modified by the factors as specified in Article 5.11.2.1.2, may be multiplied by the following factors, where:

- Reinforcement being developed in the length under consideration is spaced laterally not less than 6.0 in. center-to-center, with not less than 3.0 in. clear cover measured in the direction of the spacing..... 0.8
- Anchorage or development for the full yield strength of reinforcement is not required, or where reinforcement in flexural members is in excess of that required by analysis $\frac{(A_s \text{ required})}{(A_s \text{ provided})}$
- Reinforcement is enclosed within a spiral composed of bars of not less than 0.25 in. in diameter and spaced at not more than a 4.0 in. pitch 0.75

5.11.2.2—Deformed Bars in Compression

5.11.2.2.1—Compressive Development Length

The development length, ℓ_d , for deformed bars in compression shall not be less than either the product of the basic development length specified herein and the applicable modification factors specified in Article 5.11.2.2.2 or 8.0 in.

The basic development length, ℓ_{db} , for deformed bars in compression shall satisfy:

$$\ell_{db} \geq \frac{0.63 d_b f_y}{\sqrt{f'_c}} \tag{5.11.2.2.1-1}$$

or:

$$\ell_{db} \geq 0.3 d_b f_y \tag{5.11.2.2.1-2}$$

where:

- f_y = specified yield strength of reinforcing bars (ksi)
- f'_c = specified compressive strength of concrete at 28 days, unless another age is specified (ksi)
- d_b = diameter of bar (in.)

5.11.2.2.2—Modification Factors

The basic development length, ℓ_{db} , may be multiplied by applicable factors, where:

- Anchorage or development for the full yield strength of reinforcement is not required, or where reinforcement is provided in excess of that required by analysis..... $\frac{(A_s \text{ required})}{(A_s \text{ provided})}$
- Reinforcement is enclosed within a spiral composed of a bar of not less than 0.25 in. in diameter and spaced at not more than a 4.0 in. pitch..... 0.75

5.11.2.3—Bundled Bars

The development length of individual bars within a bundle, in tension, or compression shall be that for the individual bar, increased by 20 percent for a three-bar bundle and by 33 percent for a four-bar bundle.

For determining the factors specified in Articles 5.11.2.1.2 and 5.11.2.1.3, a unit of bundled bars shall be treated as a single bar of a diameter determined from the equivalent total area.

5.11.2.4—Standard Hooks in Tension

5.11.2.4.1—Basic Hook Development Length

The development length, ℓ_{dh} , in in., for deformed bars in tension terminating in a standard hook specified in Article 5.10.2.1 shall not be less than:

- The product of the basic development length ℓ_{hb} , as specified in Eq. 5.11.2.4.1-1, and the applicable modification factor or factors, as specified in Article 5.11.2.4.2;
- 8.0 bar diameters; or
- 6.0 in.

Basic development length, ℓ_{hb} , for a hooked-bar with yield strength, f_y , not exceeding 60.0 ksi shall be taken as:

$$\ell_{hb} = \frac{38.0 d_b}{\sqrt{f'_c}} \tag{5.11.2.4.1-1}$$

where:

- d_b = diameter of bar (in.)
- f'_c = specified compressive strength of concrete at 28 days, unless another age is specified (ksi)

5.11.2.4.2—Modification Factors

Basic hook development length, ℓ_{hb} , shall be multiplied by the following factor or factors, as applicable, where:

- Reinforcement has a yield strength exceeding 60.0 ksi..... $\frac{f_y}{60.0}$
- Side cover for No. 11 bar and smaller, normal to plane of hook, is not less than 2.5 in., and 90° hook, cover on bar extension beyond hook not less than 2.0 in. 0.7
- Hooks for No. 11 bar and smaller enclosed vertically or horizontally within ties or stirrup ties which are spaced along the full development length, ℓ_{dh} , at a spacing not exceeding $3d_b$ 0.8
- Anchorage or development of full yield strength is not required, or where reinforcement is provided in excess of that required by analysis.... $\frac{(A_s \text{ required})}{(A_s \text{ provided})}$
- Lightweight aggregate concrete is used 1.3

C5.11.2.4.1

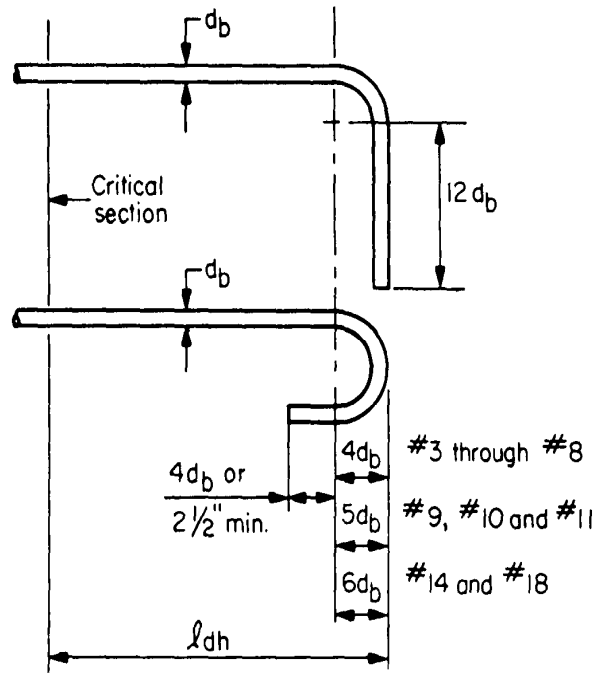

Figure C5.11.2.4-1—Hooked-Bar Details for Development of Standard Hooks (ACI)

C5.11.2.4.2

- Epoxy-coated reinforcement is used 1.2

Recent tests indicate that the development length for hooked-bars should be increased by 20 percent to account for reduced bond when reinforcement is epoxy-coated. The proposed change was adopted by ACI Committee 318 in the 1992 edition of the *Building Code Requirements for Reinforced Concrete* (Hamad et al., 1990).

5.11.2.4.3—Hooked-Bar Tie Requirements

For bars being developed by a standard hook at discontinuous ends of members with both side cover and top or bottom cover less than 2.5 in., the hooked-bar shall be enclosed within ties or stirrups spaced along the full development length, ℓ_{dh} , not greater than $3d_b$ as shown in Figure 5.11.2.4.3-1. The factor for transverse reinforcement, as specified in Article 5.11.2.4.2, shall not apply.

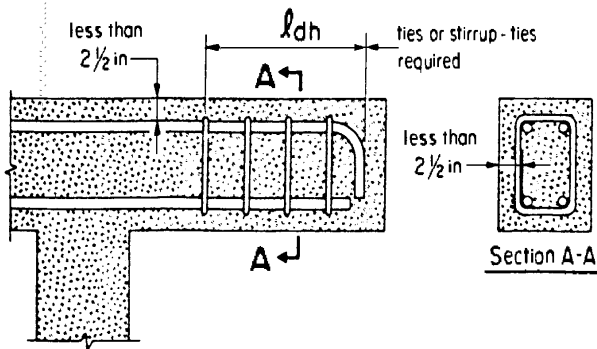

Figure 5.11.2.4.3-1—Hooked-Bar Tie Requirements

5.11.2.5—Welded Wire Fabric

5.11.2.5.1—Deformed Wire Fabric

For applications other than shear reinforcement, the development length, ℓ_{hd} , in in., of welded deformed wire fabric, measured from the point of critical section to the end of wire, shall not be less than either:

- The product of the basic development length and the applicable modification factor or factors, as specified in Article 5.11.2.2.2, or
- 8.0 in., except for lap splices, as specified in Article 5.11.6.1.

The development of shear reinforcement shall be taken as specified in Article 5.11.2.6.

The basic development length, ℓ_{hd} , for welded deformed wire fabric, with not less than one cross wire within the development length at least 2.0 in. from the point of critical section, shall satisfy:

$$\ell_{hd} \leq 0.95 d_b \frac{f_y - 20.0}{\sqrt{f'_c}}, \text{ or} \quad (5.11.2.5.1-1)$$

$$\ell_{hd} \leq 6.30 \frac{A_w f_y}{s_w \sqrt{f'_c}} \quad (5.11.2.5.1-2)$$

where:

A_w = area of an individual wire to be developed or spliced (in.²)

s_w = spacing of wires to be developed or spliced (in.)

The basic development length of welded deformed wire fabric, with no cross wires within the development length, shall be determined as for deformed wire in accordance with Article 5.11.2.1.1.

5.11.2.5.2—Plain Wire Fabric

The yield strength of welded plain wire fabric shall be considered developed by embedment of two cross wires with the closer cross wire not less than 2.0 in. from the point of critical section. Otherwise, the development length, ℓ_d , measured from the point of critical section to outermost cross wire shall be taken as:

$$\ell_d = 8.50 \frac{A_w f_y}{s_w \sqrt{f'_c}} \quad (5.11.2.5.2-1)$$

The development length shall be modified for reinforcement in excess of that required by analysis as specified in Article 5.11.2.4.2, and by the factor for lightweight concrete specified in Article 5.11.2.1.2, where applicable. However, ℓ_d shall not be taken to be less than 6.0 in., except for lap splices as specified in Article 5.11.6.2.

5.11.2.6—Shear Reinforcement

5.11.2.6.1—General

Stirrup reinforcement in concrete pipe shall satisfy the provisions of Article 12.10.4.2.7 and shall not be required to satisfy the provisions herein.

Shear reinforcement shall be located as close to the surfaces of members as cover requirements and proximity of other reinforcement permit.

Between anchored ends, each bend in the continuous portion of a simple U-stirrup or multiple U-stirrup shall enclose a longitudinal bar.

Longitudinal bars bent to act as transverse reinforcement, if extended into a region of tension, shall be continuous with the longitudinal reinforcement and, if extended into a region of compression, shall be

anchored beyond the middepth, $h/2$, as specified for development length for that part of the stress in the reinforcement required to satisfy Eq. 5.8.3.3-5.

5.11.2.6.2—Anchorage of Deformed Reinforcement

Ends of single-leg, simple U-, or multiple U-stirrups shall be anchored as follows:

- For No. 5 bar and D31 wire, and smaller, and for No. 6, No. 7 and No. 8 bars with f_y of 40.0 ksi or less:

A standard hook around longitudinal reinforcement, and

- For No. 6, No. 7 and No. 8 stirrups with f_y greater than 40.0 ksi:

A standard stirrup hook around a longitudinal bar, plus one embedment length between midheight of the member and the outside end of the hook, ℓ_e shall satisfy:

$$\ell_e \geq \frac{0.44 d_b f_y}{\sqrt{f'_c}} \quad (5.11.2.6.2-1)$$

5.11.2.6.3—Anchorage of Wire Fabric Reinforcement

C5.11.2.6.3

Each leg of welded plain wire fabric forming simple U-stirrups shall be anchored by:

- Two longitudinal wires spaced at 2.0 in. along the member at the top of the U, or
- One longitudinal wire located not more than $d/4$ from the compression face and a second wire closer to the compression face and spaced not less than 2.0 in. from the first wire. The second wire may be located on the stirrup leg beyond a bend or on a bend with an inside diameter of bend not less than $8d_b$.

For each end of a single-leg stirrup of welded plain or deformed wire fabric, two longitudinal wires at a minimum spacing of 2.0 in. and with the inner wire at not less than $d/4$ or 2.0 in. from middepth of member shall be provided. The outer longitudinal wire at tension face shall not be farther from the face than the portion of primary flexural reinforcement closest to the face.

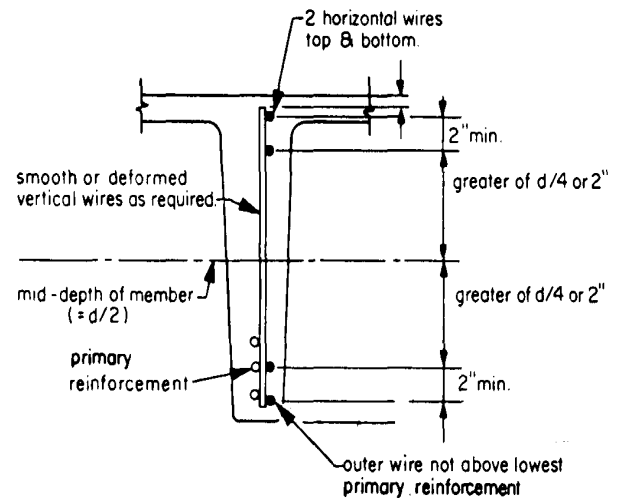

Figure C5.11.2.6.3-1—Anchorage of Single-Leg Welded Wire Fabric Shear Reinforcement, ACI (1989)

5.11.2.6.4—Closed Stirrups

Pairs of U-stirrups or ties that are placed to form a closed unit shall be considered properly anchored and spliced where length of laps are not less than $1.7 \ell_d$, where ℓ_d in this case is the development length for bars in tension.

In members not less than 18.0 in. deep, closed stirrup splices with the tension force resulting from factored loads, $A_b f_y$, not exceeding 9.0 kips per leg, may be considered adequate if the stirrup legs extend the full available depth of the member.

Transverse torsion reinforcement shall be made fully continuous and shall be anchored by 135-degree standard hooks around longitudinal reinforcement.

5.11.3—Development by Mechanical Anchorages

Any mechanical device capable of developing the strength of reinforcement without damage to concrete may be used as an anchorage. Performance of mechanical anchorages shall be verified by laboratory tests.

Development of reinforcement may consist of a combination of mechanical anchorage and the additional embedment length of reinforcement between the point of maximum bar stress and the mechanical anchorage.

If mechanical anchorages are to be used, complete details shall be shown in the contract documents.

5.11.4—Development of Prestressing Strand

5.11.4.1—General

In determining the resistance of pretensioned concrete components in their end zones, the gradual buildup of the strand force in the transfer and development lengths shall be taken into account.

C5.11.3

Standard details for such devices have not been developed.

C5.11.4.1

Between the end of the transfer length and development length, the strand stress grows from the effective stress in the prestressing steel after losses to the stress in the strand at nominal resistance of the member.

The stress in the prestressing steel may be assumed to vary linearly from 0.0 at the point where bonding commences to the effective stress after losses, f_{pe} , at the end of the transfer length.

Between the end of the transfer length and the development length, the strand stress may be assumed to increase linearly, reaching the stress at nominal resistance, f_{ps} , at the development length.

For the purpose of this Article, the transfer length may be taken as 60 strand diameters and the development length shall be taken as specified in Article 5.11.4.2.

The effects of debonding shall be considered as specified in Article 5.11.4.3.

5.11.4.2—Bonded Strand

Pretensioning strand shall be bonded beyond the section required to develop f_{ps} for a development length, ℓ_d , in in., where ℓ_d shall satisfy:

$$\ell_d \geq \kappa \left(f_{ps} - \frac{2}{3} f_{pe} \right) d_b \quad (5.11.4.2-1)$$

where:

- d_b = nominal strand diameter (in.)
- f_{ps} = average stress in prestressing steel at the time for which the nominal resistance of the member is required (ksi)
- f_{pe} = effective stress in the prestressing steel after losses (ksi)
- κ = 1.0 for pretensioned panels, piling, and other pretensioned members with a depth of less than or equal to 24.0 in.
- κ = 1.6 for pretensioned members with a depth greater than 24.0 in.

The variation of design stress in the pretensioned strand from the free end of the strand may be calculated as follows:

- From the point where bonding commences to the end of transfer length:

$$f_{px} = \frac{f_{pe} \ell_{px}}{60d_b} \quad (5.11.4.2-2)$$

- From the end of the transfer length and to the end of the development of the strand:

$$f_{px} = f_{pe} + \frac{\ell_{px} - 60d_b}{(\ell_d - 60d_b)} (f_{ps} - f_{pe}) \quad (5.11.4.2-3)$$

where:

C5.11.4.2

An October, 1988 FHWA memorandum mandated a 1.6 multiplier on Eq. 5.11.4.2-1 in the specifications. The corrected equation is conservative in nature, but accurately reflects the worst-case characteristics of strands shipped prior to 1997. To eliminate the need for this multiplier, Eq. 5.11.4.2-1 has been modified by the addition of the κ factor.

The correlation between steel stress and the distance over which the strand is bonded to the concrete can be idealized by the relationship shown in Figure C5.11.4.2-1. This idealized variation of strand stress may be used for analyzing sections within the transfer and development length at the end of pretensioned members.

- ℓ_{px} = distance from free end of pretensioned strand to section of member under consideration (in.)
- f_{px} = design stress in pretensioned strand at nominal flexural strength at section of member under consideration (ksi)

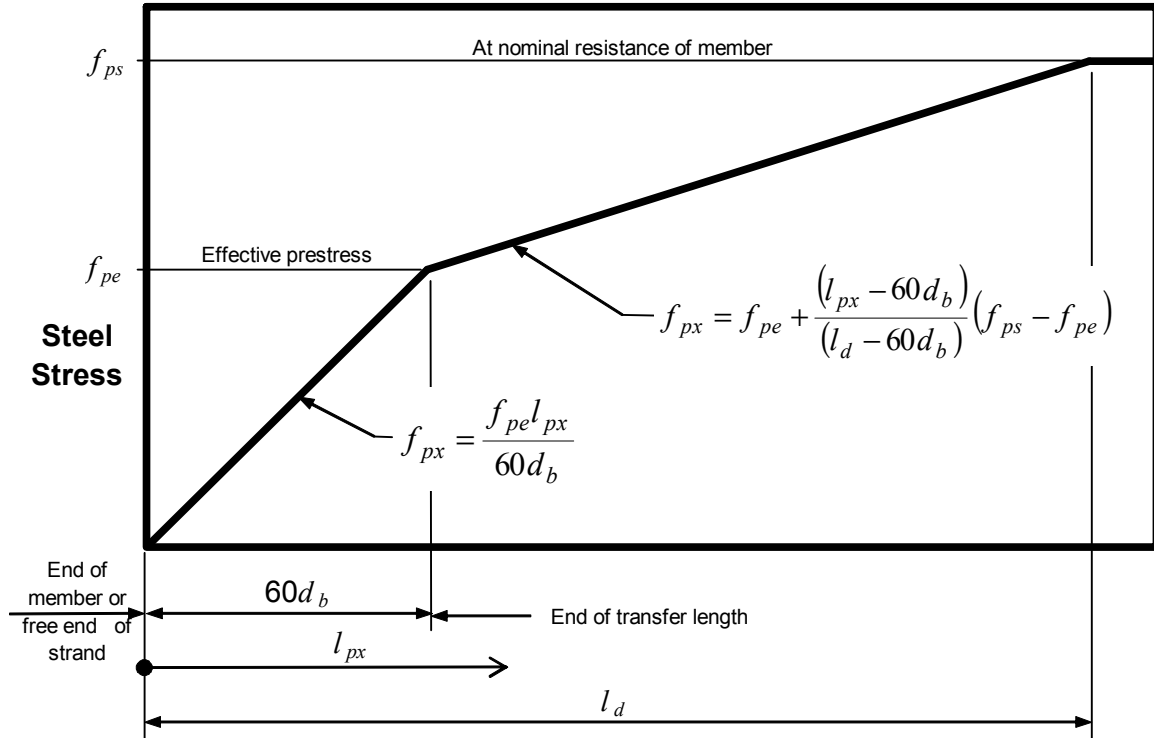

Figure C5.11.4.2-1—Idealized Relationship between Steel Stress and Distance from the Free End of Strand

5.11.4.3—Partially Debonded Strands

C5.11.4.3

Where a portion or portions of a pretensioning strand are not bonded and where tension exists in the precompressed tensile zone, the development length, measured from the end of the debonded zone, shall be determined using Eq. 5.11.4.2-1 with a value of $\kappa = 2.0$.

The number of partially debonded strands should not exceed 25 percent of the total number of strands.

The number of debonded strands in any horizontal row shall not exceed 40 percent of the strands in that row.

The length of debonding of any strand shall be such that all limit states are satisfied with consideration of the total developed resistance at any section being investigated. Not more than 40 percent of the debonded strands, or four strands, whichever is greater, shall have the debonding terminated at any section.

Debonded strands shall be symmetrically distributed about the centerline of the member. Debonded lengths of pairs of strands that are symmetrically positioned about the centerline of the member shall be equal.

Exterior strands in each horizontal row shall be fully bonded.

Tests completed by the Florida Department of Transportation (Shahawy, Robinson, and Batchelor, 1993; Shahawy and Batchelor, 1991) indicate that the anchored strength of the strands is one of the primary contributors to the shear resistance of prestressed concrete beams in their end zones. The recommended limit of 25 percent of debonded strands is derived from those tests. Shear capacity was found to be inadequate with full-scale girders where 40 percent of strands were debonded.

Some states have had success with greater percentages of partially debonded strands. Successful past practice should always be considered, but the shear resistance in the region should be thoroughly investigated with due regard to the reduction in horizontal force available when considering the free body diagram in Figure C5.8.3.5-1 and to all other determinations of shear capacity by any of the provisions of this section.

Research at various institutions was conducted validating that pretensioned strands that are partially debonded have a longer development length.

5.11.5—Splices of Bar Reinforcement

For reinforcement conforming to the requirements of ASTM A1035/A1035M, the value of f_y used in this Article shall be taken as 100 ksi.

5.11.5.1—Detailing

Permissible locations, types, and dimensions of splices, including staggers, for reinforcing bars shall be shown in the contract documents.

5.11.5.2—General Requirements

5.11.5.2.1—Lap Splices

The lengths of lap for lap splices of individual bars shall be as specified in Articles 5.11.5.3.1 and 5.11.5.5.1.

Lap splices within bundles shall be as specified in Article 5.11.2.3. Individual bar splices within a bundle shall not overlap. Entire bundles shall not be lap spliced.

For reinforcement in tension, lap splices shall not be used for bars larger than No. 11.

Bars spliced by noncontact lap splices in flexural members shall not be spaced farther apart transversely than one-fifth the required lap splice length or 6.0 in.

For columns with longitudinal reinforcing that anchors into oversized shafts, where bars are spliced by noncontact lap splices, and longitudinal column and shaft reinforcement are spaced farther apart transversely than one-fifth the required lap splice length or 6.0 in., the spacing of the shaft transverse reinforcement in the splice zone shall meet the requirements of the following equation:

$$S_{\max} = \frac{2\pi A_{sh} f_{yr} \ell_s}{k A_{\ell} f_{u\ell}} \quad (5.11.5.2.1-1)$$

where:

- S_{\max} = spacing of transverse shaft reinforcement (in.)
- A_{sh} = area of shaft spiral or transverse reinforcement (in.²)
- f_{yr} = specified minimum yield strength of shaft transverse reinforcement (ksi)
- ℓ_s = Class C tension lap splice length of the column longitudinal reinforcement (in.)
- A_{ℓ} = area of longitudinal column reinforcement (in.²)
- $f_{u\ell}$ = specified minimum tensile strength of column longitudinal reinforcement (ksi), 90 ksi for ASTM A615 and 80 ksi for ASTM A706
- k = factor representing the ratio of column tensile reinforcement to total column reinforcement at the nominal resistance

C5.11.5.2.1

This ratio, k , could be determined from the column moment-curvature analysis using appropriate computer programs. For simplification, $k = 0.5$ could safely be used in most applications.

The development length of column longitudinal reinforcement in drilled shafts is from WSDOT-TRAC Report WA-RD 417.1 titled *Noncontact Lap Splices in Bridge Column-Shaft Connections*.

5.11.5.2.2—Mechanical Connections

The resistance of a full-mechanical connection shall not be less than 125 percent of the specified yield strength of the bar in tension or compression, as required. The total slip of the bar within the splice sleeve of the connector after loading in tension to 30.0 ksi and relaxing to 3.0 ksi shall not exceed the following measured displacements between gage points clear of the splice sleeve:

- For bar sizes up to No. 14 0.01 in.
- For No. 18 bars 0.03 in.

5.11.5.2.3—Welded Splices

Welding for welded splices shall conform to the current edition of *Structural Welding Code—Reinforcing Steel of AWS* (D1.4).

A full-welded splice shall be required to develop, in tension, at least 125 percent of the specified yield strength of the bar.

No welded splices shall be used in decks.

5.11.5.3—Splices of Reinforcement in Tension

5.11.5.3.1—Lap Splices in Tension

The length of lap for tension lap splices shall not be less than either 12.0 in. or the following for Class A, B or C splices:

- Class A splice 1.0 ℓ_d
- Class B splice 1.3 ℓ_d
- Class C splice 1.7 ℓ_d

The tension development length, ℓ_d , for the specified yield strength shall be taken in accordance with Article 5.11.2.

The class of lap splice required for deformed bars and deformed wire in tension shall be as specified in Table 5.11.5.3.1-1.

Table 5.11.5.3.1-1—Classes of Tension Lap Splices

Ratio of (A_s as provided) (A_s as required)	Percent of A_s Spliced with Required Lap Length		
	50	75	100
≥ 2	A	A	B
< 2	B	C	C

C5.11.5.2.2

The stress versus slip criteria has been developed by the California Department of Transportation.

Types of mechanical connectors in use include the sleeve-threaded type, the sleeve-filler metal type and the sleeve-swaged type, of which many are proprietary, commercially available devices. The contract documents should include a testing and approval procedure wherever a proprietary type of connector is used.

Basic information about the various types of proprietary mechanical connection devices is given in ACI 439.3R (1991).

C5.11.5.2.3

The limitation of a full-welded splice to only butt-welded bars that was included in previous editions of the Standard Specifications was deleted. The purpose of this requirement is unknown, but it may have been an indirect consequence of concern about fatigue of other types of welded splices. It should be noted that this Article requires all welding of reinforcing bar splices to conform to the latest edition of the AWS Code, and that this Code limits lap welded splices to bar size No. 6 and smaller.

C5.11.5.3

The tension development length, ℓ_d , used as a basis for calculating splice lengths should include all of the modification factors specified in Article 5.11.2.

5.11.5.3.2—Mechanical Connections or Welded Splices in Tension

C5.11.5.3.2

Mechanical connections or welded tension splices, used where the area of reinforcement provided is less than twice that required, shall meet the requirements for full-mechanical connections or full-welded splices.

Mechanical connections or welded splices, used where the area of reinforcement provided is at least twice that required by analysis and where the splices are staggered at least 24.0 in., may be designed to develop not less than either twice the tensile force effect in the bar at the section or half the minimum specified yield strength of the reinforcement.

In determining the tensile force effect developed at each section, spliced reinforcement may be considered to resist the specified splice strength. Unspliced reinforcement may be considered to resist the fraction of f_y defined by the ratio of the shorter actual development length to the development length, ℓ_d , required to develop the specified yield strength f_y .

5.11.5.4—Splices in Tension Tie Members

C5.11.5.4

Splices of reinforcement in tension tie members shall be made only with either full-welded splices or full-mechanical connections. Splices in adjacent bars shall be staggered not less than 30.0 in. apart.

A tension tie member is assumed to have:

- An axial tensile force sufficient to create tension over the cross-section, and
- A level of stress in the reinforcement such that every bar is fully effective.

Examples of members that may be classified as tension ties are arch ties, hangers carrying load to an overhead supporting structure, and main tension components in a truss.

5.11.5.5—Splices of Bars in Compression

5.11.5.5.1—Lap Splices in Compression

C5.11.5.5.1

The length of lap, ℓ_c , for compression lap splices shall not be less than 12.0 in. or as follows:

- If $f_y \leq 60.0$ ksi then:

$$\ell_c = 0.5mf_y d_b \tag{5.11.5.5.1-1}$$

or:

- If $f_y > 60.0$ ksi then:

$$\ell_c = m(0.9f_y - 24.0)d_b \tag{5.11.5.5.1-2}$$

in which:

- Where the specified concrete strength, f'_c , is less than 3.0 ksi $m = 1.33$
- Where ties along the splice have an effective area not less than 0.15 percent of the product of the thickness of the compression component times the tie spacing $m = 0.83$
- With spirals $m = 0.75$
- In all other cases $m = 1.0$

The effective area of the ties is the area of the legs perpendicular to the thickness of the component, as seen in cross-section.

where:

f_y = specified yield strength of reinforcing bars (ksi)
 d_b = diameter of bar (in.)

Where bars of different size are lap spliced in compression, the splice length shall not be less than the development length of the larger bar or the splice length of smaller bar. Bar sizes No. 14 and No. 18 may be lap spliced to No. 11 and smaller bars.

5.11.5.5.2—Mechanical Connections or Welded Splices in Compression

Mechanical connections or welded splices used in compression shall satisfy the requirements for full-mechanical connections or full-welded splices as specified in Articles 5.11.5.2.2 and 5.11.5.2.3, respectively.

5.11.5.5.3—End-Bearing Splices

In bars required for compression only, the compressive force may be transmitted by bearing on square-cut ends held in concentric contact by a suitable device. End-bearing splices shall be used only in members confined by closed ties, closed stirrups, or spirals.

The end-bearing splices shall be staggered, or continuing bars shall be provided at splice locations. The continuing bars in each face of the member shall have a factored tensile resistance not less than $0.25f_y$ times the area of the reinforcement in that face.

5.11.6—Splices of Welded Wire Fabric

5.11.6.1—Splices of Welded Deformed Wire Fabric in Tension

When measured between the ends of each fabric sheet, the length of lap for lap splices of welded deformed wire fabric with cross wires within the lap length shall not be less than $1.3\ell_{hd}$ or 8.0 in. The overlap measured between the outermost cross wires of each fabric sheet shall not be less than 2.0 in.

Lap splices of welded deformed wire fabric with no cross wires within the lap splice length shall be determined as for deformed wire in accordance with the provisions of Article 5.11.5.3.1.

5.11.6.2—Splices of Welded Smooth Wire Fabric in Tension

Where the area of reinforcement provided is less than twice that required at the splice location, the length of overlap measured between the outermost cross wires of each fabric sheet shall not be less than:

- The sum of one spacing of cross wires plus 2.0 in., or
- $1.5\ell_d$, or
- 6.0 in.

where:

ℓ_d = development length specified in Article 5.11.2 (in.)

Where the area of reinforcement provided is at least twice that required at the splice location, the length of overlap measured between the outermost cross wires of each fabric sheet shall not be less than $1.5\ell_d$ or 2.0 in.

5.12—DURABILITY

5.12.1—General

Concrete structures shall be designed to provide protection of the reinforcing and prestressing steel against corrosion throughout the life of the structure.

Special requirements that may be needed to provide durability shall be indicated in the contract documents. Portions of the structure shall be identified where:

- Air-entrainment of the concrete is required,
- Epoxy-coated or galvanized reinforcement is required,
- Special concrete additives are required,
- The concrete is expected to be exposed to salt water or to sulfate soils or water, and
- Special curing procedures are required.

Protective measures for durability shall satisfy the requirements specified in Article 2.5.2.1.

C5.12.1

Design considerations for durability include concrete quality, protective coatings, minimum cover, distribution and size of reinforcement, details, and crack widths. Further guidance can be found in ACI Committee Report 222 (ACI, 1987) and Posten et al. (1987).

The principal aim of these Specifications, with regard to durability is the prevention of corrosion of the reinforcing steel. There are provisions in *AASHTO LRFD Bridge Construction Specifications* for air-entrainment of concrete and some special construction procedures for concrete exposed to sulfates or salt water. For unusual conditions, the contract documents should augment the provisions for durability.

The critical factors contributing to the durability of concrete structures are:

- Adequate cover over reinforcement,
- Nonreactive aggregate-cement combinations,
- Thorough consolidation of concrete,
- Adequate cement content,
- Low W/C ratio, and
- Thorough curing, preferably with water.

The use of air-entrainment is generally recommended when 20 or more cycles of freezing and thawing per year are expected at the location and exposure. Decks and rails are most vulnerable, whereas buried footings are seldom damaged by freeze-thaw action.

Sulfate soils or water, sometimes called alkali, contain high levels of sulfates of sodium, potassium, calcium, or magnesia. Salt water, water soluble sulfate in soil above 0.1 percent or sulfates in water above 150 ppm justify use of the special construction procedures called for in *AASHTO LRFD Bridge Construction Specifications*. These include avoidance of

construction joints between the levels of low water and the upper limit of wave action. For sulfate contents above 0.2 percent in soil or 1,500 ppm in water, special concrete mixes may be justified. Further guidance may be found in ACI 201 or the *Concrete Manual* (1981).

5.12.2—Alkali-Silica Reactive Aggregates

The provisions of *AASHTO LRFD Bridge Construction Specifications* Article 8.3.4 shall apply.

5.12.3—Concrete Cover

Cover for unprotected prestressing and reinforcing steel shall not be less than that specified in Table 5.12.3-1 and modified for W/C ratio, unless otherwise specified either herein or in Article 5.12.4.

Concrete cover and placing tolerances shall be shown in the contract documents.

Cover for pretensioned prestressing strand, anchorage hardware, and mechanical connections for reinforcing bars or post-tensioned prestressing strands shall be the same as for reinforcing steel.

Cover for metal ducts for post-tensioned tendons shall not be less than:

- That specified for main reinforcing steel,
- One-half the diameter of the duct, or
- That specified in Table 5.12.3-1.

For decks exposed to tire studs or chain wear, additional cover shall be used to compensate for the expected loss in depth due to abrasion, as specified in Article 2.5.2.4.

Modification factors for W/C ratio shall be the following:

- For $W/C \leq 0.40$ 0.8
- For $W/C \geq 0.50$ 1.2

Minimum cover to main bars, including bars protected by epoxy coating, shall be 1.0 in.

Cover to ties and stirrups may be 0.5 in. less than the values specified in Table 5.12.3-1 for main bars but shall not be less than 1.0 in.

C5.12.3

The concrete cover modification factor used in conjunction with Table 5.12.3-1 recognizes the decreased permeability resulting from a lower W/C ratio.

Minimum cover is necessary for durability and prevention of splitting due to bond stresses and to provide for placing tolerance.

Table 5.12.3-1—Cover for Unprotected Main Reinforcing Steel (in.)

Situation	Cover (in.)
Direct exposure to salt water	4.0
Cast against earth	3.0
Coastal	3.0
Exposure to deicing salts	2.5
Deck surfaces subject to tire stud or chain wear	2.5
Exterior other than above	2.0
Interior other than above	
• Up to No. 11 bar	1.5
• No. 14 and No. 18 bars	2.0
Bottom of cast-in-place slabs	
• Up to No. 11 bar	1.0
• No. 14 and No. 18 bars	2.0
Precast soffit form panels	0.8
Precast reinforced piles	
• Noncorrosive environments	2.0
• Corrosive environments	3.0
Precast prestressed piles	2.0
Cast-in-place piles	
• Noncorrosive environments	2.0
• Corrosive environments	
- General	3.0
- Protected	3.0
• Shells	2.0
• Auger-cast, tremie concrete, or slurry construction	3.0

5.12.4—Protective Coatings

Protection against chloride-induced corrosion may be provided by epoxy coating or galvanizing of reinforcing steel, post-tensioning duct, and anchorage hardware and by epoxy coating of prestressing strand. Cover to epoxy-coated steel may be as shown for interior exposure in Table 5.12.3-1.

5.12.5—Protection for Prestressing Tendons

Ducts for internal post-tensioned tendons, designed to provide bonded resistance, shall be grouted after stressing. Other tendons shall be permanently protected against corrosion and the details of protection shall be indicated in the contract documents.

C5.12.4

Specifications for acceptable epoxy coatings are included in the materials section of *AASHTO LRFD Bridge Construction Specifications*.

C5.12.5

In certain cases, such as the tying together of longitudinal precast elements by transverse post-tensioning, the integrity of the structure does not depend on the bonded resistance of the tendons, but rather on the confinement provided by the prestressing elements. The unbonded tendons can be more readily inspected and replaced, one at a time, if so required.

External tendons have been successfully protected by cement grout in polyethylene or metal tubing. Tendons have also been protected by heavy grease or other anticorrosion medium where future replacement is envisioned. Tendon anchorage regions should be protected by encapsulation or other effective means. This is critical in unbonded tendons because any failure of the anchorage can release the entire tendon.

5.13—SPECIFIC MEMBERS

5.13.1—Deck Slabs

Requirements for deck slabs in addition to those specified in Section 5 shall be as specified in Section 9.

5.13.2—Diaphragms, Deep Beams, Brackets, Corbels, and Beam Ledges

5.13.2.1—General

Diaphragms, brackets, corbels, beam ledges, and other deep members subjected primarily to shear and torsion and whose depth is large relative to their span shall be designed as specified herein.

Deep beams shall be analyzed and designed by either the strut-and-tie model, specified in Article 5.6.3, or another recognized theory.

5.13.2.2—Diaphragms

Unless otherwise specified, diaphragms shall be provided at abutments, piers, and hinge joints to resist lateral forces and transmit loads to points of support.

Intermediate diaphragms may be used between beams in curved systems or where necessary to provide torsional resistance and to support the deck at points of discontinuity or at angle points in girders.

Intermediate diaphragms may be used between beams in curved systems or where necessary to provide torsional resistance and to support the deck at points of discontinuity or at right angle points of discontinuity or at angle points in girders.

For spread box beams having an inside radius less than 800 ft, intermediate diaphragms shall be used.

C5.13.2.1

For a structural depth that is large relative to span length, the definition of a deep component, given in Article 5.2, may be used.

As noted in the Commentary for Article 5.6.3, the sectional design model method is not valid for some deep members; they should be designed by a strut-and-tie model.

Another recognized theory for design of these components can be found in Article 11.8 of ACI 318.

C5.13.2.2

In certain types of construction, end diaphragms may be replaced by an edge beam or a strengthened strip of slab made to act as a vertical frame with the beam ends. Such types are low I-beams and double-T beams. These frames should be designed for wheel loads.

The diaphragms should be essentially solid, except for access openings and utility holes, where required.

For curved bridges, the need for and the required spacing of diaphragms depends on the radius of curvature and the proportions of the webs and flanges. Some references have found that interior diaphragms contributed very little to the global behavior of concrete box girder bridges.

Figure C5.13.2.2-1 illustrates the application of the strut-and-tie model to analysis of forces in a prestressed interior diaphragm of a box girder bridge

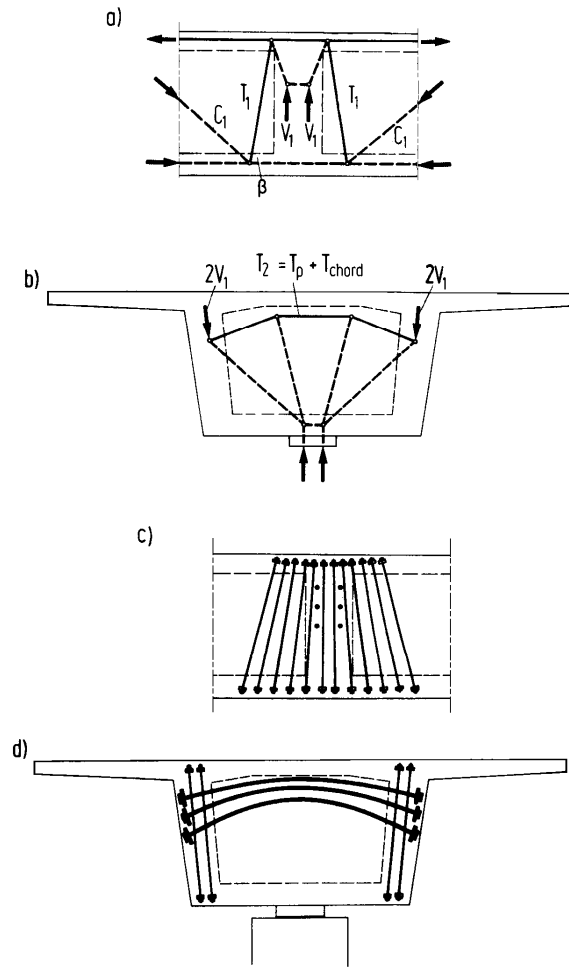

Figure C5.13.2.2-1—Diaphragm of a Box Girder Bridge: (a) Disturbed Regions and Model of the Web near the Diaphragm; (b) Diaphragm and Model; (c) and (d) Prestressing of the Web and the Diaphragm (Schlaich et al., 1987)

5.13.2.3—Detailing Requirements for Deep Beams

The factored tensile resistance, N_R in kips, of transverse pair of reinforcing bars shall satisfy:

$$N_R = \phi f_y A_s \geq 0.12 b_v s \tag{5.13.2.3-1}$$

where:

- b_v = width of web (in.)
- f_y = yield strength of reinforcing steel (ksi)
- A_s = area of steel in distance s (in.²)
- ϕ = resistance factor specified in Article 5.5.4.2
- s = spacing of reinforcement (in.)

C5.13.2.3

Figure C5.13.2.3-1 shows an application of the strut-and-tie model to analysis of deep beams.

The spacing of transverse reinforcement, s , shall not exceed $d/4$ or 12.0 in.

Bonded longitudinal bars shall be well distributed over each face of the vertical elements in pairs. The tensile resistance of a bonded reinforcement pair shall not be less than that specified in Eq. 5.13.2.3-1. The vertical spacing between each pair of reinforcement, s , shall not exceed either $d/3$ or 12.0 in. For components whose width is less than 10.0 in., a single bar of the required tensile resistance may be used in lieu of a pair of longitudinal bars.

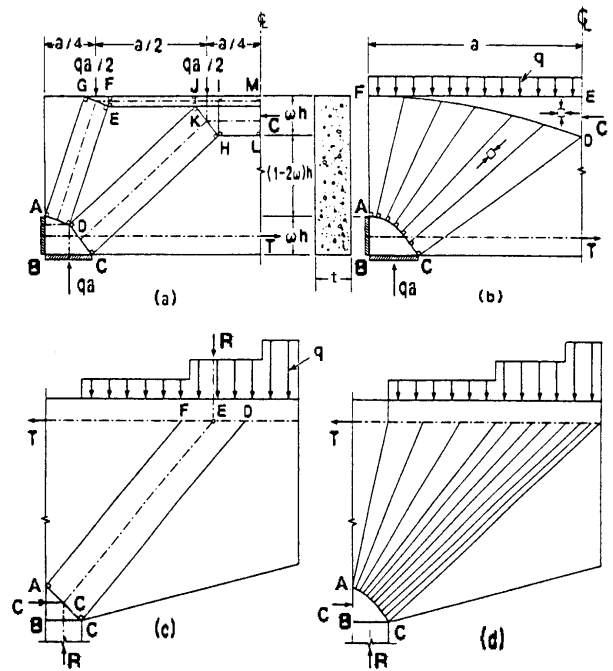

Figure C5.13.2.3-1—Fan Action: (a) Strut-and-Tie Model of Uniformly-Loaded Deep Beam; (b) Fan-Shaped Stress Field; (c) Strut-and-Tie System for Equivalent Single-Load R Replacing Distributed-Load q ; (d) Continuous Fan Developed from Discrete Strut

5.13.2.4—Brackets and Corbels

5.13.2.4.1—General

Components in which a_v , as shown in Figure 5.13.2.4.1-1, is less than d shall be considered to be brackets or corbels. If a_v is greater than d , the component shall be designed as a cantilever beam.

C5.13.2.4.1

Figure C5.13.2.4.1-1 illustrates the application of strut-and-tie models to analysis of brackets and corbels.

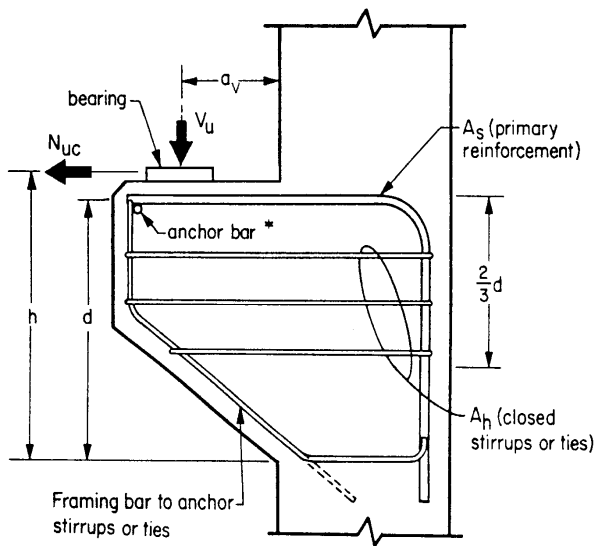

*Welded to primary reinforcement

Figure 5.13.2.4.1-1—Notation

The section at the face of support shall be designed to resist simultaneously a factored shear force V_u , a factored moment

$$M_u = V_u a_v + N_{uc} (h - d) \tag{5.13.2.4.1-1}$$

and a concurrent factored horizontal tensile force N_{uc} . Unless special provisions are made to prevent the tensile force, N_{uc} , from developing, it shall not be taken to be less than $0.2V_u$. N_{uc} shall be regarded as a live load, even where it results from creep, shrinkage, or temperature change.

The steel ratio of A_s/bd at the face of the support shall not be less than $0.04f'_c/f_y$ where d is measured at the face of the support.

The total area, A_h , of the closed stirrups or ties shall not be less than 50 percent of the area, A_s , of the primary tensile tie reinforcement. Stirrups or ties shall be uniformly distributed within two-thirds of the effective depth adjacent to the primary tie reinforcement.

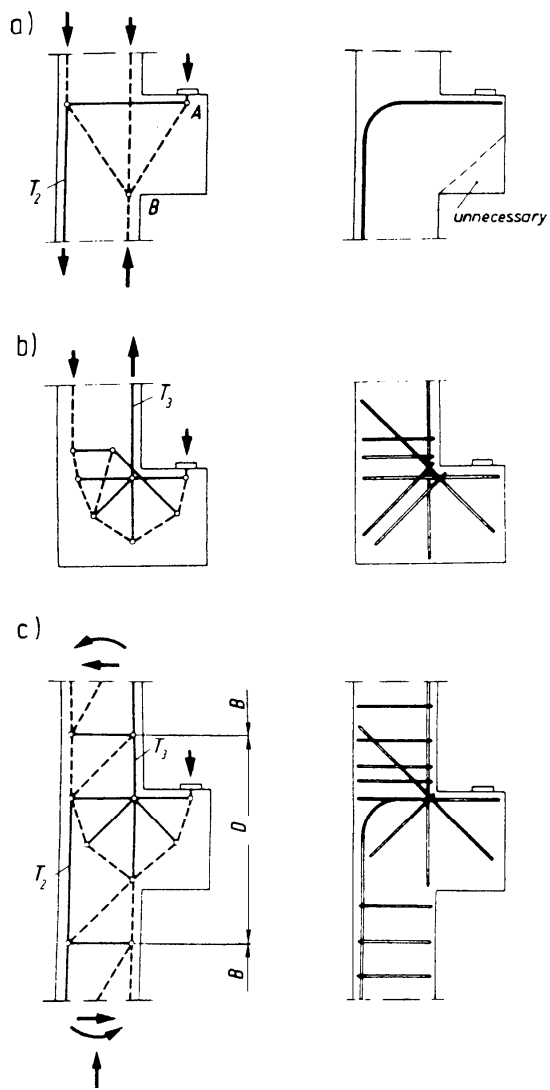

Figure C5.13.2.4.1-1—Different Support Conditions Leading to Different Strut-and-Tie Models and Different Reinforcement Arrangements of Corbels and Beam Ledges (Schlaich et al., 1987)

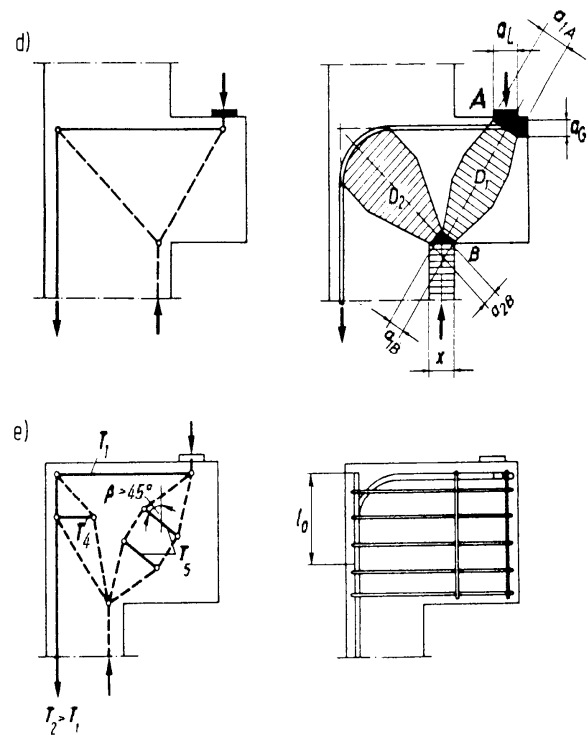

Figure C5.13.2.4.1-1 (continued) —Different Support Conditions Leading to Different Strut-and-Tie Models and Different Reinforcement Arrangements of Corbels and Beam Ledges (Schlaich et al., 1987)

At the front face of a bracket or corbel, the primary tension reinforcement shall be anchored to develop the specified yield strength, f_y .

The bearing area on a bracket or corbel shall not project either beyond the straight portion of the primary tension bars or beyond the interior face of any transverse anchor bar.

The depth at the outside edge of the bearing area shall not be less than half the depth at the face of the support.

5.13.2.4.2—Alternative to Strut-and-Tie Model

The section at the face of the support for brackets and corbels may be designed in accordance with either the strut-and-tie method specified in Article 5.6.3 or the provisions of Article 5.13.2.4.1, with the following exceptions:

Anchorage for developing reinforcement may include:

- A structural weld to a transverse bar of at least equal size,
- Bending the primary bars down to form a continuous loop, or
- Some other positive means of anchorage.

- Design of shear-friction reinforcement, A_{vf} , to resist the factored shear force, V_u , shall be as specified in Article 5.8.4, except that:

For normal weight concrete, nominal shear resistance, V_n , shall satisfy:

$$V_n = 0.2 f'_c b_w d_e \quad (5.13.2.4.2-1)$$

$$V_n = 0.8 b_w d_e \quad (5.13.2.4.2-2)$$

For all lightweight or sand-lightweight concretes, nominal shear resistance, V_n , shall satisfy:

$$V_n = (0.2 - 0.07 a_v / d) f'_c b_w d_e \text{ (kips) and} \quad (5.13.2.4.2-3)$$

$$V_n = (0.8 - 0.28 a_v / d_e) b_w d \text{ (kips)} \quad (5.13.2.4.2-4)$$

- Reinforcement, A_s , to resist the factored force effects shall be determined as for ordinary members subjected to flexure and axial load.
- Area of primary tension reinforcement, A_s , shall satisfy:

$$A_s \geq \frac{2A_{vf}}{3} + A_n, \text{ and} \quad (5.13.2.4.2-5)$$

- The area of closed stirrups or ties placed within a distance equal to $2d_e/3$ from the primary reinforcement shall satisfy:

$$A_n \geq 0.5(A_s - A_n) \quad (5.13.2.4.2-6)$$

in which:

$$A_n \geq N_{uc} / \Phi f_y \quad (5.13.2.4.2-7)$$

where:

b_w = web width (in.)
 d_e = depth of center of gravity of steel (in.)
 A_{vf} = area of shear friction steel (in.²)

5.13.2.5—Beam Ledges

5.13.2.5.1—General

As illustrated in Figure 5.13.2.5.1-1, beam ledges shall resist:

- Flexure, shear, and horizontal forces at the location of Crack 1;

C5.13.2.5.1

Beam ledges may be distinguished from brackets and corbels in that their width along the face of the supporting member is greater than $(W + 5a_f)$, as shown in Figure 5.13.2.5.3-1. In addition, beam ledges are supported primarily by tension ties to the supporting member, whereas corbels utilize a compression strut

- Tension force in the supporting element at the location of Crack 2;
- Punching shear at points of loading at the location of Crack 3; and
- Bearing force at the location of Crack 4.

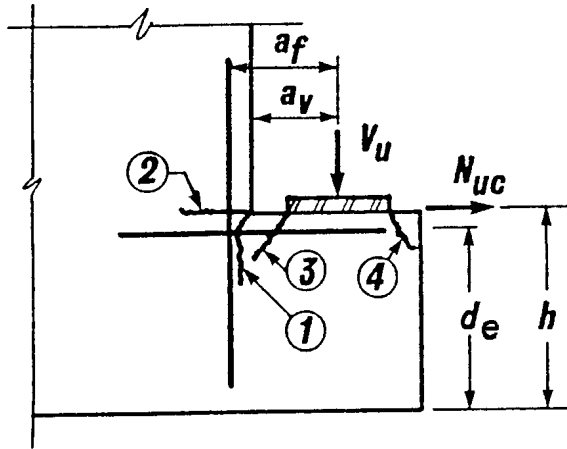

Figure 5.13.2.5.1-1—Notation and Potential Crack Locations for Ledge Beams

Beam ledges may be designed in accordance with either the strut-and-tie model or the provisions of Articles 5.13.2.5.2 through 5.13.2.5.5. Bars shown in Figures 5.13.2.5.2-1 through 5.13.2.5.5-2 shall be properly developed in accordance with Article 5.11.1.1.

penetrating directly into the supporting member. Beam ledges are generally continuous between points of application of bearing forces. Daps should be considered to be inverted beam ledges.

Examples of beam ledges include hinges within spans and inverted T-beam caps, as illustrated in Figure C5.13.2.5.1-1.

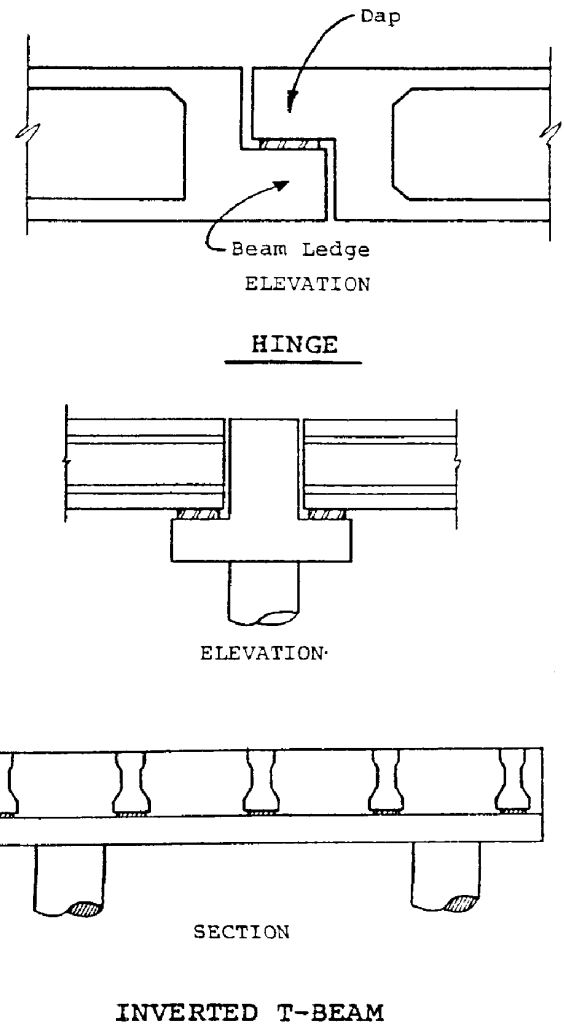

Figure C5.13.2.5.1-1—Examples of Beam Ledges

5.13.2.5.2—Design for Shear

Design of beam ledges for shear shall be in accordance with the requirements for shear friction specified in Article 5.8.4. Nominal interface shear resistance shall satisfy Eqs. 5.13.2.4.2-1 through 5.13.2.4.2-4 wherein the width of the concrete face, b_w , assumed to participate in resistance to shear shall not exceed S , $(W + 4a_v)$, or $2c$, as illustrated in Figure 5.13.2.5.2-1.

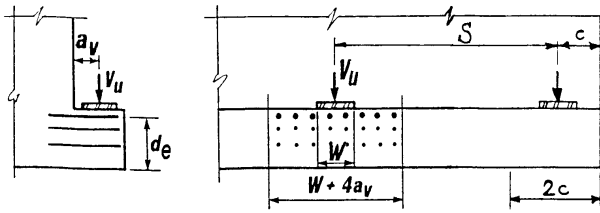

Figure 5.13.2.5.2-1—Design of Beam Ledges for Shear

5.13.2.5.3—Design for Flexure and Horizontal Force

The area of total primary tension reinforcement, A_s , shall satisfy the requirements of Article 5.13.2.4.2.

The primary tension reinforcement shall be spaced uniformly within the region $(W + 5a_f)$ or $2c$, as illustrated in Figure 5.13.2.5.3-1, except that the widths of these regions shall not overlap.

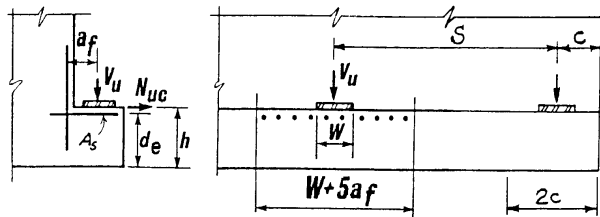

Figure 5.13.2.5.3-1—Design of Beam Ledges for Flexure and Horizontal Force

5.13.2.5.4—Design for Punching Shear

The truncated pyramids assumed as failure surfaces for punching shear, as illustrated in Figure 5.13.2.5.4-1, shall not overlap.

Nominal punching shear resistance, V_n , in kips, shall be taken as:

- At interior pads, or exterior pads where the end distance c is greater than $S/2$:

$$V_n = 0.125 \sqrt{f'_c} (W + 2L + 2d_e) d_e \tag{5.13.2.5.4-1}$$

- At exterior pads where the end distance c is less than $S/2$ and $c - 0.5W$ is less than d_e :

$$V_n = 0.125 \sqrt{f'_c} (W + L + d_e) d_e \tag{5.13.2.5.4-2}$$

- At exterior pads where the end distance c is less than $S/2$, but $c - 0.5W$ is greater than d_e :

$$V_n = 0.125 \sqrt{f'_c} (0.5W + L + d_e + c) d_e \tag{5.13.2.5.4-3}$$

C5.13.2.5.4

The area of concrete resisting the punching shear for each concentrated load is shown in Figure 5.13.2.5.4-1. The area of the truncated pyramid is approximated as the average of the perimeter of the bearing plate or pad and the perimeter at depth d , assuming 45-degree slopes. If the pyramids overlap, an investigation of the combined surface areas will be necessary.

where:

- f'_c = specified strength of concrete at 28 days (ksi)
 W = width of bearing plate or pad as shown in Figure 5.13.2.5.4-1 (in.)
 L = length of bearing pad as shown in Figure 5.13.2.5.4-1 (in.)
 d_e = effective depth from extreme compression fiber to centroid of tensile force (in.)

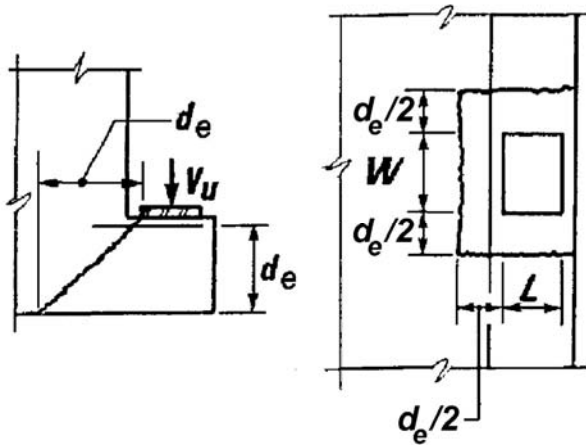

Figure 5.13.2.5.4-1—Design of Beam Ledges for Punching Shear

5.13.2.5.5—Design of Hanger Reinforcement

The hanger reinforcement specified herein shall be provided in addition to the lesser shear reinforcement required on either side of the beam reaction being supported.

The arrangement for hanger reinforcement, A_{hr} , in single-beam ledges shall be as shown in Figure 5.13.2.5.5-1.

Using the notation in Figure 5.13.2.5.5-1, the nominal shear resistance, V_n , in kips, for single-beam ledges shall be taken as:

- For the service limit state:

$$V_n = \frac{A_{hr}(0.5f_y)}{s}(W + 3a_v) \quad (5.13.2.5.5-1)$$

- For the strength limit state:

$$V_n = \frac{A_{hr}f_y}{s}S \quad (5.13.2.5.5-2)$$

where:

- A_{hr} = area of one leg of hanger reinforcement as illustrated in Figure 5.13.2.5.5-1 (in.²)
 S = spacing of bearing places (in.)
 s = spacing of hangers (in.)

f_y = yield strength of reinforcing steel (ksi)
 a_v = distance from face of wall to the load as illustrated in Figure 5.13.2.5.5-1 (in.)

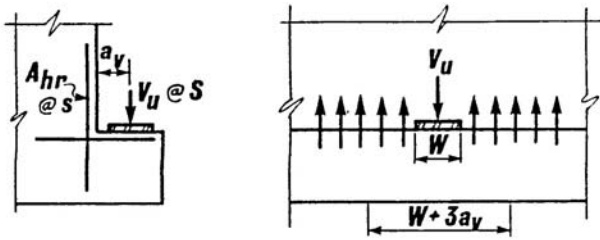

Figure 5.13.2.5.5-1—Single-Ledge Hanger Reinforcement

Using the notation in Figure 5.13.2.5.5-2, the nominal shear resistance of the ledges of inverted T-beams shall be the lesser of that specified by Eq. 5.13.2.5.5-2 and Eq. 5.13.2.5.5-3.

$$V_n = (0.063\sqrt{f'_c}b_f d_f) + \frac{A_{hr} f_y}{s} (W + 2d_f) \quad (5.13.2.5.5-3)$$

where:

d_f = distance from top of ledge to compression reinforcement as illustrated in Figure 5.13.2.5.5-2 (in.)

The edge distance between the exterior bearing pad and the end of the inverted T-beam shall not be less than d_f .

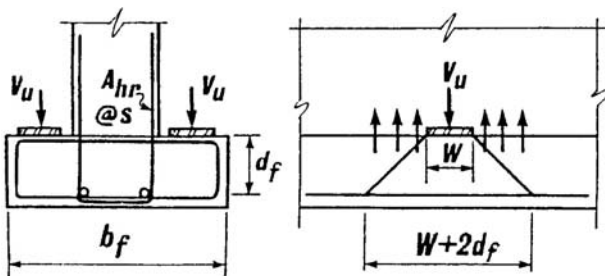

Figure 5.13.2.5.5-2—Inverted T-Beam Hanger Reinforcement

Inverted T-beams shall satisfy the torsional moment provisions as specified in Articles 5.8.3.6 and 5.8.2.1.

5.13.2.5.6—Design for Bearing

For the design for bearings supported by beam ledges, the provisions of Article 5.7.5 shall apply.

5.13.3—Footings

5.13.3.1—General

Provisions herein shall apply to the design of isolated footings, combined footings, and foundation mats.

In sloped or stepped footings, the angle of slope or depth and location of steps shall be such that design requirements are satisfied at every section.

Circular or regular polygon-shaped concrete columns or piers may be treated as square members with the same area for the location of critical sections for moment, shear, and development of reinforcement in footings.

5.13.3.2—Loads and Reactions

The resistance of foundation material for piles shall be as specified in Section 10, “Foundations.”

Where an isolated footing supports a column, pier, or wall, the footing shall be assumed to act as a cantilever. Where a footing supports more than one column, pier, or wall, the footing shall be designed for the actual conditions of continuity and restraint.

For the design of footings, unless the use of special equipment is specified to ensure precision driving of piles, it shall be assumed that individual driven piles may be out of planned position in a footing by either 6.0 in. or one-quarter of the pile diameter and that the center of a group of piles may be 3.0 in. from its planned position. For pile bents, the contract documents may require a 2.0 in. tolerance for pile position, in which case that value should be accounted for in the design.

5.13.3.3—Resistance Factors

For determination of footing size and number of piles, the resistance factors, ϕ , for soil-bearing pressure and for pile resistance as a function of the soil shall be as specified in Section 10.

5.13.3.4—Moment in Footings

The critical section for flexure shall be taken at the face of the column, pier, or wall. In the case of columns that are not rectangular, the critical section shall be taken at the side of the concentric rectangle of equivalent area. For footings under masonry walls, the critical section shall be taken as halfway between the center and edge of the wall. For footings under metallic column bases, the critical section shall be taken as halfway between the column face and the edge of the metallic base.

C5.13.3.1

Although the provisions of Article 5.13.3 apply to isolated footings supporting a single column or wall, most of the provisions are generally applicable to combined footings and mats supporting several columns or walls or a combination thereof.

C5.13.3.2

The assumption that the as-built location of piles may differ from the planned location recognizes the construction variations sometimes encountered and is consistent with the tolerances allowed by *AASHTO LRFD Bridge Construction Specifications*. Lesser variations may be assumed if the contract documents require the use of special equipment, such as templates, for more precise driving.

For noncircular piles, the larger cross-sectional dimension should be used as the “diameter.”

C5.13.3.4

Moment at any section of a footing may be determined by passing a vertical plane through the footing and computing the moment of the forces acting on one side of that vertical plane.

5.13.3.5—Distribution of Moment Reinforcement

In one-way footings and two-way square footings, reinforcement shall be distributed uniformly across the entire width of the footing.

The following guidelines apply to the distribution of reinforcement in two-way rectangular footings:

- In the long direction, reinforcement shall be distributed uniformly across the entire width of footing.
- In the short direction, a portion of the total reinforcement as specified by Eq. 5.13.3.5-1, shall be distributed uniformly over a band width equal to the length of the short side of footing and centered on the centerline of column or pier. The remainder of reinforcement required in the short direction shall be distributed uniformly outside of the center band width of footing. The area of steel in the band width shall satisfy Eq. 5.13.3.5-1.

$$A_{s-BW} = A_{s-SD} \left(\frac{2}{\beta + 1} \right) \quad (5.13.3.5-1)$$

where:

- β = ratio of the long side to the short side of footing
- A_{s-BW} = area of steel in the band width (in.²)
- A_{s-SD} = total area of steel in short direction (in.²)

5.13.3.6—Shear in Slabs and Footings

5.13.3.6.1—Critical Sections for Shear

In determining the shear resistance of slabs and footings in the vicinity of concentrated loads or reaction forces, the more critical of the following conditions shall govern:

- One-way action, with a critical section extending in a plane across the entire width and located at a distance taken as specified in Article 5.8.3.2.
- Two-way action, with a critical section perpendicular to the plane of the slab and located so that its perimeter, b_o , is a minimum but not closer than $0.5d_v$ to the perimeter of the concentrated load or reaction area
- Where the slab thickness is not constant, critical sections located at a distance not closer than $0.5d_v$ from the face of any change in the slab thickness and located such that the perimeter, b_o , is a minimum

C5.13.3.6.1

In the general case of a cantilever retaining wall, where the downward load on the heel is larger than the upward reaction of the soil under the heel, the critical section for shear is taken at the back face of the stem, as illustrated in Figure C5.13.3.6.1-1, in which d_v is the effective depth for shear.

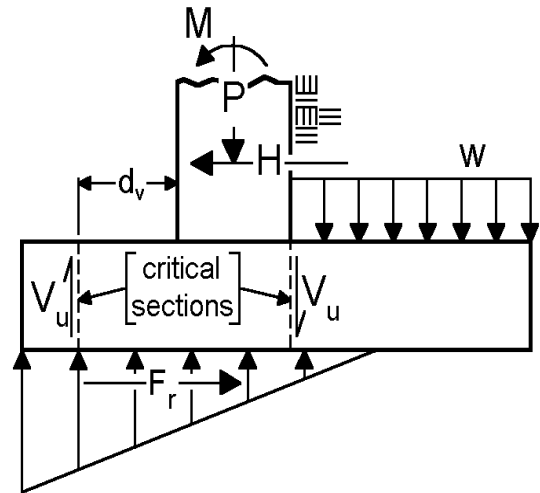

Figure C5.13.3.6.1-1—Example of Critical Section for Shear in Footings

Where a portion of a pile lies inside the critical section, the pile load shall be considered to be uniformly distributed across the width or diameter of the pile, and the portion of the load outside the critical section shall be included in the calculation of shear on the critical section.

5.13.3.6.2—One-Way Action

For one-way action, the shear resistance of the footing or slab shall satisfy the requirements specified in Article 5.8.3, except for culverts with over 2.0 ft or more of fill, for which the provisions of Article 5.14.5.3 shall apply.

5.13.3.6.3—Two-Way Action

For two-way action for sections without transverse reinforcement, the nominal shear resistance, V_n in kips, of the concrete shall be taken as:

$$V_n = \left(0.063 + \frac{0.126}{\beta_c} \right) \sqrt{f'_c} b_o d_v \leq 0.126 \sqrt{f'_c} b_o d_v \quad (5.13.3.6.3-1)$$

where:

β_c = ratio of long side to short side of the rectangle through which the concentrated load or reaction force is transmitted

If a haunch has a rise-to-span ratio of 1:1 or more where the rise is in the direction of the shear force under investigation, it may be considered an abrupt change in section, and the design section may be taken as d_v into the span with d_v taken as the effective depth for shear past the haunch.

If a large-diameter pile is subjected to significant flexural moments, the load on the critical section may be adjusted by considering the pile reaction on the footing to be idealized as the stress distribution resulting from the axial load and moment.

C5.13.3.6.3

The traditional expression for punching shear resistance has been retained.

If shear perimeters for individual loads overlap or project beyond the edge of the member, the critical perimeter b_o should be taken as that portion of the smallest envelope of individual shear perimeter that will actually resist the critical shear for the group under consideration. One such situation is illustrated in Figure C5.13.3.6.3-1.

b_o = perimeter of the critical section (in.)
 d_v = effective shear depth (in.)

Where $V_u > \phi V_n$, shear reinforcement shall be added in compliance with Article 5.8.3.3, with angle θ taken as 45 degrees.

For two-way action for sections with transverse reinforcement, the nominal shear resistance, in kips, shall be taken as:

$$V_n = V_c + V_s \leq 0.192 \sqrt{f'_c} b_o d_v \quad (5.13.3.6.3-2)$$

in which:

$$V_c = 0.0632 \sqrt{f'_c} b_o d_v, \text{ and} \quad (5.13.3.6.3-3)$$

$$V_s = \frac{A_v f_y d_v}{s} \quad (5.13.3.6.3-4)$$

5.13.3.7—Development of Reinforcement

For the development of reinforcement in slabs and footings, the provisions of Article 5.11 shall apply.

Critical sections for development of reinforcement shall be assumed to be at the locations specified in Article 5.13.3.4 and at all other vertical planes where changes of section or reinforcement occur.

5.13.3.8—Transfer of Force at Base of Column

All forces and moments applied at the base of a column or pier shall be transferred to the top of footing by bearing on concrete and by reinforcement. Bearing on concrete at the contact surface between the supporting and supported member shall not exceed the concrete-bearing strength, as specified in Article 5.7.5, for either surface.

Lateral forces shall be transferred from the pier to the footing in accordance with shear-transfer provisions specified in Article 5.8.4 on the basis of the appropriate bulleted item in Article 5.8.4.3.

Reinforcement shall be provided across the interface between supporting and supported member, either by extending the main longitudinal column or wall reinforcement into footings or by using dowels or anchor bolts.

Reinforcement across the interface shall satisfy the following requirements:

- All force effects that exceed the concrete bearing strength in the supporting or supported member shall be transferred by reinforcement;
- If load combinations result in uplift, the total tensile force shall be resisted by the reinforcement; and

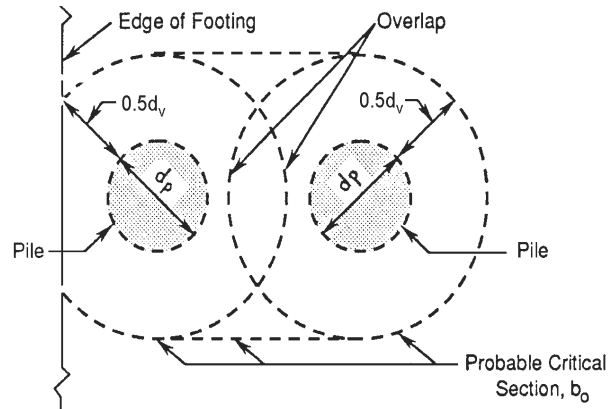

Figure C5.13.3.6.3-1—Modified Critical Section for Shear with Overlapping Critical Perimeters

- The area of reinforcement shall not be less than 0.5 percent of the gross area of the supported member, and the number of bars shall not be less than four.

The diameter of dowels, if used, shall not exceed the diameter of longitudinal reinforcement by more than 0.15 in.

At footings, the No. 14 and No. 18 main column longitudinal reinforcement that is in compression only may be lap spliced with footing dowels to provide the required area. Dowels shall be no larger than No. 11 and shall extend into the column a distance not less than either the development length of the No. 14 or No. 18 bars or the splice length of the dowels and into the footing a distance not less than the development length of the dowels.

5.13.4—Concrete Piles

5.13.4.1—General

All loads resisted by the footing and the weight of the footing itself shall be assumed to be transmitted to the piles. Piles installed by driving shall be designed to resist driving and handling forces. For transportation and erection, a precast pile should be designed for not less than 1.5 times its self-weight.

Any portion of a pile where lateral support adequate to prevent buckling may not exist at all times shall be designed as a column.

The points or zones of fixity for resistance to lateral loads and moments shall be determined by an analysis of the soil properties, as specified in Article 10.7.3.13.4.

Concrete piles shall be embedded into footings or pile caps, as specified in Article 10.7.1.1. Anchorage reinforcement shall consist of either an extension of the pile reinforcement or the use of dowels. Uplift forces or stresses induced by flexure shall be resisted by the reinforcement. The steel ratio for anchorage reinforcement shall not be less than 0.005, and the number of bars shall not be less than four. The reinforcement shall be developed sufficiently to resist a force of $1.25f_yA_s$.

In addition to the requirements specified in Articles 5.13.4.1 through 5.13.4.5, piles used in the seismic zones shall conform to the requirements specified in Article 5.13.4.6.

5.13.4.2—Splices

Splices in concrete of piles shall develop the axial, flexural, shear, and torsional resistance of the pile. Details of splices shall be shown in the contract documents.

C5.13.4.1

The material directly under a pile-supported footing is not assumed to carry any of the applied loads.

Locations where such lateral support does not exist include any portion of a pile above the anticipated level of scour or future excavation as well as portions that extend above ground, as in pile bents.

C5.13.4.2

AASHTO LRFD Bridge Construction Specifications has provisions for short extensions or “buildups” for the tops of concrete piles. This allows for field corrections due to unanticipated events, such as breakage of heads or driving slightly past the cutoff elevation.

5.13.4.3—Precast Reinforced Piles

5.13.4.3.1—Pile Dimensions

C5.13.4.3.1

Precast concrete piles may be of uniform section or tapered. Tapered piling shall not be used for trestle construction, except for that portion of the pile that lies below the ground line, or in any location where the piles are to act as columns.

Where concrete piles are not exposed to salt water, they shall have a cross-sectional area measured above the taper of not less than 140 in.² Concrete piles used in salt water shall have a cross-sectional area of not less than 220 in.² The corners of a rectangular section shall be chamfered.

The diameter of tapered piles measured 2.0 ft from the point shall be not less than 8.0 in. where, for all pile cross-sections, the diameter shall be considered as the least dimension through the center of cross-section.

A 1.0-in. connection chamfer is desirable, but smaller chamfers have been used successfully. Local experience should be considered.

5.13.4.3.2—Reinforcing Steel

Longitudinal reinforcement shall consist of not less than four bars spaced uniformly around the perimeter of the pile. The area of reinforcing steel shall not be less than 1.5 percent of the gross concrete cross-sectional area measured above the taper.

The full length of longitudinal steel shall be enclosed with spiral reinforcement or equivalent hoops. The spiral reinforcement shall be as specified in Article 5.13.4.4.3.

5.13.4.4—Precast Prestressed Piles

5.13.4.4.1—Pile Dimensions

Prestressed concrete piles may be octagonal, square, or circular and shall conform to the minimum dimensions specified in Article 5.13.4.3.1.

Prestressed concrete piles may be solid or hollow. For hollow piles, precautionary measures, such as venting, shall be taken to prevent breakage due to internal water pressure during driving, ice pressure in trestle piles, or gas pressure due to decomposition of material used to form the void.

The wall thickness of cylinder piles shall not be less than 5.0 in.

5.13.4.4.2—Concrete Quality

The compressive strength of the pile at the time of driving shall not be less than 5.0 ksi. Air-entrained concrete shall be used in piles that are subject to freezing and thawing or wetting and drying.

5.13.4.4.3—Reinforcement

Unless otherwise specified by the Owner, the prestressing strands should be spaced and stressed to provide a uniform compressive stress on the cross-section of the pile after losses of not less than 0.7 ksi.

The full length of the prestressing strands shall be enclosed with spiral reinforcement as follows:

For piles not greater than 24.0 in. in diameter:

- Spiral wire not less than W3.9,
- Spiral reinforcement at the ends of piles having a pitch of 3.0 in. for approximately 16 turns,
- The top 6.0 in. of pile having five turns of additional spiral winding at 1.0-in. pitch, and
- For the remainder of the pile, the strands enclosed with spiral reinforcement with not more than 6.0-in. pitch.

For piles greater than 24.0 in. in diameter:

- Spiral wire not less than W4.0,
- Spiral reinforcement at the end of the piles having a pitch of 2.0 in. for approximately 16 turns,
- The top 6.0 in. having four additional turns of spiral winding at 1.5-in. pitch, and
- For the remainder of the pile, the strands enclosed with spiral reinforcement with not more than 4.0-in. pitch.

5.13.4.5—Cast-in-Place Piles

Piles cast in drilled holes may be used only where soil conditions permit.

Shells for cast-in-place piles shall be of sufficient thickness and strength to hold their form and to show no harmful distortion during driving or after adjacent shells have been driven and the driving core, if any, has been withdrawn. The contract documents shall stipulate that alternative designs of the shell need be approved by the Engineer before any driving is done.

C5.13.4.4.3

The purpose of the 0.7 ksi compression is to prevent cracking during handling and installation. A lower compression may be used if approved by the Owner.

For noncircular piles, use the least dimension through the cross-section in place of the “diameter.”

C5.13.4.5

Cast-in-place concrete piles include piles cast in driven steel shells that remain in place and piles cast in unlined drilled holes or shafts.

The construction of piles in drilled holes should generally be avoided in sloughing soils, where large cobblestones exist or where uncontrollable groundwater is expected. The special construction methods required under these conditions increase both the cost and the probability of defects in the piles.

The thickness of shells should be shown in the contract documents as “minimum.” This minimum thickness should be that needed for pile reinforcement or for strength required for usual driving conditions: e.g., 0.134 in. minimum for 14.0-in. pile shells driven without a mandrel. *AASHTO LRFD Bridge Construction Specifications* requires the Contractor to furnish shells of greater thickness, if necessary, to permit his choice of driving equipment.

5.13.4.5.1—*Pile Dimensions*

Cast-in-place concrete piles may have a uniform section or may be tapered over any portion if cast in shells or may be bell-bottomed if cast in drilled holes or shafts.

The area at the butt of the pile shall be at least 100 in.² The cross-sectional area at the tip of the pile shall be at least 50.0 in.². For pile extensions above the butt, the minimum size shall be as specified for precast piles in Article 5.13.4.3.

5.13.4.5.2—*Reinforcing Steel*

The area of longitudinal reinforcement shall not be less than 0.8 percent of A_g , with spiral reinforcement not less than W3.9 at a pitch of 6.0 in. The reinforcing steel shall be extended 10.0 ft below the plane where the soil provides adequate lateral restraint.

Shells that are more than 0.12 in. in thickness may be considered as part of the reinforcement. In corrosive environments, a minimum of 0.06 in. shall be deducted from the shell thickness in determining resistance.

For cast-in-place concrete piling, clear distance between parallel longitudinal, and parallel transverse reinforcing bars shall not be less than five times the maximum aggregate size or 5.0 in., except as noted in Article 5.13.4.6 for seismic requirements.

5.13.4.6—**Seismic Requirements**

5.13.4.6.1—*Zone 1*

No additional design provisions need be considered for Zone 1.

5.13.4.6.2—*Zone 2*

5.13.4.6.2a—*General*

Piles for structures in Zone 2 may be used to resist both axial and lateral loads. The minimum depth of embedment and axial and lateral pile resistances required for seismic loads shall be determined by means of design criteria established by site-specific geological and geotechnical investigations.

Concrete piles shall be anchored to the pile footing or cap by either embedment of reinforcement or anchorages to develop uplift forces. The embedment length shall not be less than the development length required for the reinforcement specified in Article 5.11.2.

Concrete-filled pipe piles shall be anchored with steel dowels as specified in Article 5.13.4.1, with a minimum steel ratio of 0.01. Dowels shall be embedded as required for concrete piles. Timber and steel piles, including unfilled pipe piles, shall be provided with anchoring devices to develop any uplift forces. The uplift force shall not be taken to be less than ten percent of the factored axial compressive resistance of the pile.

5.13.4.6.2b—Cast-in-Place Piles

For cast-in-place piles, longitudinal steel shall be provided in the upper end of the pile for a length not less than either one-third of the pile length or 8.0 ft, with a minimum steel ratio of 0.005 provided by at least four bars. For piles less than 24.0 in. in diameter, spiral reinforcement or equivalent ties of not less than No. 3 bars shall be provided at pitch not exceeding 9.0 in., except that the pitch shall not exceed 4.0 in. within a length below the pile cap reinforcement of not less than 2.0 ft or 1.5 pile diameters, whichever is greater. See Articles 5.10.11.3 and 5.10.11.4.

5.13.4.6.2c—Precast Reinforced Piles

For precast reinforced piles, the longitudinal steel shall not be less than 1.0 percent of the cross-sectional area and provided by not less than four bars. Spiral reinforcement or equivalent ties of not less than No. 3 bars shall be provided at a pitch not exceeding 9.0 in., except that a 3.0 in. pitch shall be used within a confinement length not less than 2.0 ft or 1.5 pile diameters below the pile cap reinforcement.

5.13.4.6.2d—Precast Prestressed Piles

For precast prestressed piles, the ties shall conform to the requirements of precast piles, as specified in Article 5.13.4.6.2c.

*5.13.4.6.3—Zones 3 and 4**5.13.4.6.3a—General*

In addition to the requirements specified for Zone 2, piles in Zones 3 and 4 shall conform to the provisions specified herein.

5.13.4.6.3b—Confinement Length

The upper end of every pile shall be reinforced and confined as a potential plastic hinge region, except where it can be established that there is no possibility of any significant lateral deflection in the pile. The potential plastic hinge region shall extend from the underside of the pile cap over a length of not less than 2.0 pile diameters or 24.0 in. If an analysis of the bridge and pile system indicates that a plastic hinge can form at a lower level, the confinement length with the specified transverse reinforcement and closer pitch, as specified in Article 5.13.4.6.2, shall extend thereto.

C5.13.4.6.2b

Cast-in-place concrete pilings may only have been vibrated directly beneath the pile cap, or in the uppermost sections. Where concrete is not vibrated, nondestructive tests in the State of California have shown that voids and rock pockets form when adhering to maximum confinement steel spacing limitations from some seismic recommendations. Concrete does not readily flow through the resulting clear distances between bar reinforcing, weakening the concrete section, and compromising the bending resistance to lateral seismic loads. Instead of reduced bar spacing, bar diameters should be increased which results in larger openings between the parallel longitudinal and transverse reinforcing steel.

C5.13.4.6.3b

Note the special requirements for pile bents given in Article 5.10.11.4.1.

5.13.4.6.3c—Volumetric Ratio for Confinement

The volumetric ratio of transverse reinforcement within the confinement length shall be that for columns, as specified in Article 5.10.11.4.1d.

5.13.4.6.3d—Cast-in-Place Piles

For cast-in-place piles, longitudinal steel shall be provided for the full length of the pile. In the upper two-thirds of the pile, the longitudinal steel ratio, provided by not less than four bars, shall not be less than 0.75 percent. For piles less than 24.0 in. in diameter, spiral reinforcement or equivalent ties of not less than No. 3 bars shall be provided at a pitch not exceeding 9.0 in., except that the pitch shall not exceed 4.0 in. within a length below the pile cap reinforcement of not less than 4.0 ft and where the volumetric ratio and splice details shall conform to Articles 5.10.11.4.1d, 5.10.11.4.1e, and 5.10.11.4.1f.

5.13.4.6.3e—Precast Piles

For precast piles, spiral ties shall not be less than No. 3 bars at a pitch not exceeding 9.0 in., except for the top 4.0 ft, where the pitch shall be 3.0 in. and the volumetric ratio and splice details shall conform to Article 5.10.11.4.1d.

C5.13.4.6.3d

See Article C5.13.4.6.2b.

5.14—PROVISIONS FOR STRUCTURE TYPES

5.14.1—Beams and Girders

5.14.1.1—General

The provisions specified herein shall be applied to the design of cast-in-place and precast beams as well as girders with rectangular, I, T, bulb-T, double-T, and open- and closed-box sections.

Precast beams may resist transient loads with or without a superimposed deck. Where a structurally separate concrete deck is applied, it shall be made composite with the precast beams in accordance with the provisions of Article 5.8.4.

The flange width considered to be effective in flexure shall be that specified in Article 4.6.2.6 or Article 5.7.3.4.

C5.14.1.1

These provisions supplement the appropriate provisions of other Articles of these Specifications.

This Article applies to linear elements, either partial or full span and either longitudinal or transverse. Segmental construction is covered in Article 5.14.2. There is a large variety of possible concrete superstructure systems, some of which may fall into either category. Precast deck bridges, which utilize girder sections with integral decks, are covered in Article 5.14.4.3.

Components that directly carry live loads, i.e., incorporated elements of the deck, should be designed for the applicable provisions of Section 9 and with particular reference to minimum dimension requirements and the way the components are to be joined to provide a continuous deck.

5.14.1.2—Precast Beams*5.14.1.2.1—Preservice Conditions*

The preservice conditions of prestressed girders for shipping and erection shall be the responsibility of the contractor.

C5.14.1.2.1

AASHTO LRFD Bridge Construction Specifications places the responsibility on the Contractor to provide adequate devices and methods for the safe storage, handling, erection, and temporary bracing of precast members.

5.14.1.2.2—Extreme Dimensions

The thickness of any part of precast concrete beams shall not be less than:

Top flange.....	2.0 in.
Web, non post-tensioned.....	5.0 in.
Web, post-tensioned	6.5 in.
Bottom flange	5.0 in.

The maximum dimensions and weight of precast members manufactured at an offsite casting yard shall conform to local hauling restrictions.

C5.14.1.2.2

The 2.0-in. minimum dimension relates to bulb-T and double-T types of girders on which cast-in-place decks are used. The 5.0-in. and 6.5-in. web thicknesses have been successfully used by contractors experienced in working to close tolerances. The 5.0-in. limit for bottom flange thickness normally relates to box-type sections.

For highway transportation, the permissible load size and weight limits are constantly being revised. For large members, an investigation should be made prior to design to ensure transportability. Investigations may include driving the route or surveying route portions with known vertical or horizontal clearance problems. Contract documents should alert the contractor to weight and permitting complications as well as the possibility of law enforcement escort requirements.

When the weight or dimensions of a precast beam exceed local hauling restrictions, field splices conforming to the requirements of Article 5.14.1.3.2 may be used.

5.14.1.2.3—Lifting Devices

If it is anticipated that anchorages for lifting devices will be cast into the face of a member that will be exposed to view or to corrosive materials in the completed structure, any restriction on locations of embedded lifting devices, the depth of removal, and the method of filling the cavities after removal shall be shown in the contract documents. The depth of removal shall be not less than the depth of cover required for the reinforcing steel.

C5.14.1.2.3

AASHTO LRFD Bridge Construction Specifications allows the Contractor to select the type of lifting device for precast members provided that the Contractor accepts responsibility for their performance. Anchorages for lifting devices generally consist of loops of prestressing strand or mild steel bars, with their tails embedded in the concrete or threaded anchorage devices that are cast into the concrete.

5.14.1.2.4—Detail Design

All details of reinforcement, connections, bearing seats, inserts, or anchors for diaphragms, concrete cover, openings, and fabrication and erection tolerances shall be shown in the contract documents. For any details left to the Contractor's choice, such as prestressing materials or methods, the submittal and review of working drawings shall be required.

C5.14.1.2.4

AASHTO LRFD Bridge Construction Specifications includes general requirements pertaining to the preparation and review of working drawings, but the contract documents should specifically indicate when they are required.

5.14.1.2.5—Concrete Strength

For slow curing concretes, the 90-day compressive strength may be used for all stress combinations that occur after 90 days, provided that the gain in strength is verified by prior tests for the concrete mix utilized.

For normal weight concrete, the 90-day strength of slow curing concretes may be estimated as 115 percent of the concrete strength specified in the contract documents.

5.14.1.3—Spliced Precast Girders

5.14.1.3.1—General

The provisions herein apply to precast girders fabricated in segments that are joined or spliced longitudinally to form the girders in the final structure.

The requirements specified herein shall supplement the requirements of other sections of these Specifications for other than segmentally constructed bridges. Therefore, spliced precast girder bridges shall not be considered as segmental construction for the purposes of design. For special design cases, additional provisions for segmental construction found in Article 5.14.2 and other Articles in these Specifications may be used where appropriate.

The method of construction assumed for the design shall be shown in the contract documents. All supports required prior to the splicing of the girder shall be shown on the contract documents, including elevations and reactions. The stage of construction during which the temporary supports are removed shall also be shown on the contract documents.

The contract documents shall indicate alternative methods of construction permitted and the Contractor's responsibilities if such methods are chosen. Any changes by the Contractor to the construction method or to the design shall comply with the requirements of Article 5.14.2.5.

Stresses due to changes in the statical system, in particular, the effects of the application of load to one structural system and its removal from a different structural system, shall be accounted for. Redistribution of such stresses by creep shall be taken into account and allowance shall be made for possible variations in the creep rate and magnitude.

Spliced girder superstructures which satisfy all service limit state requirements of this Article may be designed as fully continuous at all limit states for loads applied after the girder segments are joined.

C5.14.1.2.5

This Article recognizes the behavior of slow-curing concretes, such as those containing fly-ash. It is not often that a bridge is opened to traffic before the precast components are 90 days old. The Designer may now take advantage of this, provided that the gain in strength has previously been verified by testing of the utilized concrete mix.

C5.14.1.3.1

Bridges consisting of spliced precast girder segments have been constructed in a variety of locations for many different reasons. An extensive database of spliced girder bridge projects has been compiled and is present in the appendix to Castrodale and White (2004).

Splicing of girder segments is generally performed in place, but may be performed prior to erection. The final structure may be a simple span or a continuous span unit.

In previous editions of these Specifications, spliced precast girder bridges were considered as a special case of both conventional precast girders and segmental construction. However, it is more appropriate to classify this type of structure as a conventional bridge with additional requirements at the splice locations that are based on provisions developed for segmental construction. The cross-section for bridges utilizing segmented precast girders is typically comprised of several girders with a composite deck.

Spliced precast girder bridges may be distinguished from what is referred to as "segmental construction" elsewhere in these Specifications by several features which typically include:

- The lengths of some or all segments in a bridge are a significant fraction of the span length rather than having a number of segments in each span. In some cases, the segment may be the full span length.
- Design of joints between girder segments at the service limit state does not typically govern the design for the entire length of the bridge for either construction or for the completed structure.
- Cast-in-place closure joints are usually used to join girder segments rather than match-cast joints.

Prestress losses in spliced precast girder bridges may be estimated using the provisions for other than segmentally constructed bridges in Article 5.9.5. The effects of combined pretensioning and post-tensioning and staged post-tensioning shall be considered.

When required, the effects of creep and shrinkage in spliced precast girder bridges may be estimated using the provisions for other than segmentally constructed bridges in Article 5.4.2.3.

Precast deck girder bridges, for which some or all of the deck is cast integrally with a girder, may be spliced. Spliced structures of this type, which have longitudinal joints in the deck between each deck girder, shall comply with the additional requirements of Article 5.14.4.3.

Spliced precast girders may be made continuous for some permanent loads using details for simple span precast girders made continuous. In such cases, design shall conform to the applicable requirements of Article 5.14.1.4.

- The bridge cross-section is comprised of several individual girders with a cast-in-place concrete composite deck rather than precasting the full width and depth of the superstructure as one piece. In some cases, the deck may be divided into pieces that are integrally cast with each girder. A bridge of this type is completed by connecting the girders across the longitudinal joints.
- Girder sections are used, such as bulb tee or open-topped trapezoidal boxes, rather than closed cell boxes with wide monolithic flanges.

Provisional ducts are required for segmental construction (Article 5.14.2.3.8a) to provide for possible adjustment of prestress force during construction. Similar requirements are not given for spliced precast girder bridges because of the redundancy provided by a greater number of webs and tendons, and typically lower friction losses because of fewer joint locations.

The method of construction and any required temporary support is of paramount importance in the design of spliced precast girder bridges. Such considerations often govern final conditions in the selection of section dimensions and reinforcing and/or prestressing.

Deck girder bridges are often spliced because the significant weight of the cross-section, which is comprised of both a girder and deck, may exceed usual limits for handling and transportation.

5.14.1.3.2—Joints between Segments

5.14.1.3.2a—General

Joints between girder segments shall be either cast-in-place closure joints or match-cast joints. Match-cast joints shall satisfy the requirements of Article 5.14.2.4.2.

The sequence of placing concrete for the closure joints and deck shall be specified in the contract documents.

C5.14.1.3.2a

This Article codifies current best practice, which allows the Designer considerable latitude to formulate new structural systems. The great majority of in-span construction joints have been post-tensioned. Conventionally reinforced joints have been used in a limited number of bridges.

Cast-in-place closure joints are typically used in spliced girder construction. Machined bulkheads have been used successfully to emulate match-cast epoxy joints for spliced girders. Prestress, dead load, and creep effects may cause rotation of the faces of the match-cast epoxy joints prior to splicing. Procedures for splicing the girder segments that overcome this rotation to close the match-cast joint should be shown on the contract plans.

5.14.1.3.2b—Details of Closure Joints

Precast concrete girder segments, with or without a cast-in-place slab, may be made longitudinally continuous for both permanent and transient loads with combinations of post-tensioning and/or reinforcement crossing the closure joints.

C5.14.1.3.2b

When diaphragms are provided at closure joint locations, designers should consider extending the closure joint at the exterior girder beyond the outside face of the girder. Extending the closure joint beyond the face of the exterior girder also provides improved

The width of a closure joint between precast concrete segments shall allow for the splicing of steel whose continuity is required by design considerations and the accommodation of the splicing of post-tensioning ducts. The width of a closure joint shall not be less than 12.0 in., except for joints located within a diaphragm, for which the width shall not be less than 4.0 in.

If the width of the closure joint exceeds 6.0 in., its compressive chord section shall be reinforced for confinement.

If the joint is located in the span, its web reinforcement, A_s/s , shall be the larger of that in the adjacent girders.

The face of the precast segments at closure joints shall be specified as either intentionally roughened to expose coarse aggregate, or having shear keys in accordance with Article 5.14.2.4.2.

5.14.1.3.2c—Details of Match-Cast Joints

Match-cast joints for spliced precast girder bridges shall be detailed in accordance with Article 5.14.2.4.2.

5.14.1.3.2d—Joint Design

Stress limits for temporary concrete stresses in joints before losses specified in Article 5.9.4.1 for segmentally constructed bridges shall apply at each stage of prestressing (pretensioning or post-tensioning). The concrete strength at the time the stage of prestressing is applied shall be substituted for f'_{ci} in the stress limits.

Stress limits for concrete stresses in joints at the service limit state after losses specified in Article 5.9.4.2 for segmentally constructed bridges shall apply. These stress limits shall also apply for intermediate load stages, with the concrete strength at the time of loading substituted for f'_c in the stress limits.

Resistance factors for joints specified in Article 5.5.4.2.2 for segmental construction shall apply.

The compressive strength of the closure joint concrete at a specified age shall be compatible with design stress limitations.

5.14.1.3.3—Girder Segment Design

Stress limits for temporary concrete stresses in girder segments before losses specified in Article 5.9.4.1 for other than segmentally constructed bridges shall apply at each stage of prestressing (pretensioning or post-tensioning) with due consideration for all applicable loads during construction. The concrete strength at the time the stage of prestressing is applied shall be substituted for f'_{ci} in the stress limits.

development of diaphragm reinforcement for bridges subject to extreme events.

The intent of the joint width requirement is to allow proper compaction of concrete in the cast-in-place closure joint. In some cases, narrower joints have been used successfully. Consolidation of concrete in a closure joint is enhanced when the joint is contained within a diaphragm. A wider closure joint may be used to provide more room to accommodate tolerances for potential misalignment of ducts within girder segments and misalignment of girder segments at erection.

The bottom flange near an interior support acts nearly as a column, hence the requirement for confinement steel.

The *AASHTO LRFD Bridge Construction Specifications* requires vertical joints to be keyed. However, proper attention to roughened joint preparation is expected to ensure bond between the segments, providing better shear strength than shear keys.

C5.14.1.3.2c

One or more large shear keys may be used with spliced girders rather than the multiple small amplitude shear keys indicated in Article 5.14.2.4.2. The shear key proportions specified in Article 5.14.2.4.2 should be used.

C5.14.1.3.3

Segments of spliced precast girders shall preferably be pretensioned for dead load and all applicable construction loadings to satisfy temporary stress limits in the concrete.

Temporary construction loads must be considered where these loads may contribute to critical stresses in girder segments at an intermediate stage of construction, such as when the deck slab is placed when only a

Stress limits for concrete stresses in girder segments at the service limit state after losses specified in Article 5.9.4.2 for other than segmentally constructed bridges shall apply. These stress limits shall also apply for intermediate load stages, with the concrete strength at the time of loading substituted for f'_c in the stress limits.

Where girder segments are precast without prestressed reinforcement, the provisions of Article 5.7.3.4 shall apply until post-tensioning is applied.

Where variable depth girder segments are used, the effect of inclined compression shall be considered.

The potential for buckling of tall thin web sections shall be considered.

5.14.1.3.4—Post-Tensioning

Post-tensioning may be applied either before and/or after placement of deck concrete. Part of the post-tensioning may be applied to provide girder continuity prior to placement of the deck concrete, with the remainder placed after deck concrete placement.

The contract documents shall require that all post-tensioning tendons shall be fully grouted after stressing.

Prior to grouting of post-tensioning ducts, gross cross-section properties shall be reduced by deducting the area of ducts and void areas around tendon couplers.

Post-tensioning shall be shown on the contract documents according to the requirements of Article 5.14.2.3.9.

Where tendons terminate at the top of a girder segment, the contract documents shall require that duct openings be protected during construction to prevent debris accumulation and that drains be provided at tendon low points.

In the case of multistage post-tensioning, draped ducts for tendons to be tensioned before the slab concrete is placed and attains the minimum specified compressive strength f'_{ci} shall not be located in the slab.

Where some or all post-tensioning tendons are stressed after the deck concrete is placed, provisions shall be shown on the contract plans satisfying the provisions of Article 2.5.2.3 on maintainability of the deck.

5.14.1.4—Bridges Composed of Simple Span Precast Girders Made Continuous

5.14.1.4.1—General

The provisions of this Article shall apply at the service and strength limit states as applicable.

When the requirements of Article 5.14.1.4 are satisfied, multi-span bridges composed of simple-span precast girders with continuity diaphragms cast between ends of girders at interior supports may be considered continuous for loads placed on the bridge after the continuity diaphragms are installed and have cured.

portion of the total prestress has been applied. Temporary construction loads are specified in the *AASHTO Guide Design Specifications for Bridge Temporary Works*.

Because gravity loads induce compression in the bottom flange of girders at support locations, the vertical force component from inclined flexural stresses in a haunched girder segment generally acts to reduce the applied shear. Its effect can be accounted for in the same manner as the vertical component of the longitudinal prestressing force, V_p . However, the reduction of the vertical shear force from this effect is usually neglected.

C5.14.1.3.4

Where some or all post-tensioning is applied after the deck concrete is placed, fewer post-tensioning tendons and a lower concrete strength in the closure joint may be required. However, deck replacement, if necessary, is difficult to accommodate with this construction sequence. Where all of the post-tensioning is applied before the deck concrete is placed, a greater number of post-tensioning tendons and a higher concrete strength in the closure joint may be required. However, in this case, the deck can be replaced if necessary. See Castrodale and White (2004).

See Article 5.10.3.5 for post-tensioning coupler requirements.

Where tendons terminate at the top of the girder, blockouts and pourbacks in the deck slab are required for access to the tendons and anchorages. While this arrangement has been used, it is preferable to anchor all tendons at the ends of girders. Minimizing or eliminating deck slab blockouts by placing anchorages at ends of girders reduces the potential for water seepage and corrosion at the post-tensioning tendon anchors.

This provision is to ensure that ducts as yet unsecured by concrete will not be used for active post-tensioning.

See Article 5.14.2.3.10e for deck overlay provisions.

C5.14.1.4.1

This type of bridge is generally constructed with a composite deck slab. However, with proper design and detailing, precast members used without a composite deck may also be made continuous for loads applied after continuity is established. Details of this type of construction are discussed in Miller et al. (2004).

The designer may choose to design a multi-span bridge as a series of simple spans but detail it as

The connection between girders at the continuity diaphragm shall be designed for all effects that cause moment at the connection, including restraint moments from time-dependent effects, except as allowed in Article 5.14.1.4.

The requirements specified in Article 5.14.1.4 supplement the requirements of other sections of these Specifications for fully prestressed concrete components that are not segmentally constructed.

Multi-span bridges composed of precast girders with continuity diaphragms at interior supports that are designed as a series of simple spans are not required to satisfy the requirements of Article 5.14.1.4.

5.14.1.4.2—Restraint Moments

The bridge shall be designed for restraint moments that may develop because of time-dependent or other deformations, except as allowed in Article 5.14.1.4.4.

Restraint moments shall not be included in any combination when the effect of the restraint moment is to reduce the total moment.

continuous with continuity diaphragms to eliminate expansion joints in the deck slab. This approach has been used successfully in several parts of the country.

Where this approach is used, the designer should consider adding reinforcement in the deck adjacent to the interior supports to control cracking that may occur from the continuous action of the structure.

Positive moment connections improve the structural integrity of a bridge, increasing its ability to resist extreme event and unanticipated loadings. These connections also control cracking that may occur in the continuity diaphragm. Therefore, it is recommended that positive moment connections be provided in all bridges detailed as continuous for live load.

C5.14.1.4.2

Deformations that occur after continuity is established from time-dependent effects such as creep, shrinkage and temperature variation cause restraint moments.

Restraint moments are computed at interior supports of continuous bridges but affect the design moments at all locations on the bridge. Studies show that restraint moments can be positive or negative. The magnitude and direction of the moments depend on girder age at the time continuity is established, properties of the girder and slab concrete, and bridge and girder geometry. (Mirmiran et al., 2001). The data show that the later continuity is formed, the lower the predicted values of positive restraint moment which will form. Since positive restraint moments are not desirable, waiting as long as possible after the girders are cast to establish continuity and cast the deck appears to be beneficial.

Several methods have been published for computing restraint moments (Mirmiran et al., 2001). While these methods may be useful in estimating restraint moments, designers should be aware that these methods may overestimate the restraint moments—both positive and negative. Existing structures do not show the distress that would be expected from the moments computed by some analysis methods.

Most analysis methods indicate that differential shrinkage between the girder and deck mitigates positive moment formation. Data from various projects (Miller et al., 2004; Russell et al., 2003) does not show the effects of differential shrinkage. Therefore, it is questionable whether negative moments due to differential shrinkage form to the extent predicted by analysis. Since field observations of significant negative moment distress have not been reported, negative moments caused by differential shrinkage are often ignored in design.

Estimated restraint moments are highly dependent on actual material properties and project schedules and the computed restraint moments may never develop. Therefore, a critical design moment must not be reduced by a restraint moment in case the restraint moment does not develop.

5.14.1.4.3—Material Properties

Creep and shrinkage properties of the girder concrete and the shrinkage properties of the deck slab concrete shall be determined from either:

- Tests of concrete using the same proportions and materials that will be used in the girders and deck slab. Measurements shall include the time-dependent rate of change of these properties.
- The provisions of Article 5.4.2.3.

The restraining effect of reinforcement on concrete shrinkage may be considered.

C5.14.1.4.3

The development of restraint moments is highly dependent on the creep and shrinkage properties of the girder and deck concrete. Since these properties can vary widely, measured properties should be used when available to obtain the most accurate analysis. However, these properties are rarely available during design. Therefore, the provisions of Article 5.4.2.3 may be used to estimate these properties.

Because longitudinal reinforcement in the deck slab restrains the shrinkage of the deck concrete, the apparent shrinkage is less than the free shrinkage of the deck concrete. This effect may be estimated using an effective concrete shrinkage strain, $\epsilon_{effective}$, which may be taken as:

$$\epsilon_{effective} = \epsilon_{sh} \left(\frac{A_c}{A_{tr}} \right) \quad (C5.14.1.4.3-1)$$

where:

ϵ_{sh}	= unrestrained shrinkage strain for deck concrete (in./in.)
A_c	= gross area of concrete deck slab (in. ²)
A_{tr}	= area of concrete deck slab with transformed longitudinal deck reinforcement (in. ²)
	= $A_c + A_s(n - 1)$
A_s	= total area of longitudinal deck reinforcement (in. ²)
n	= modular ratio between deck concrete and reinforcement
	= $E_s / E_{c\ deck}$
$E_{c\ deck}$	= modulus of elasticity of deck concrete (ksi)

Eq. C5.14.1.4.3-1 is based on simple mechanics (Abdalla et al., 1993). If the amount of longitudinal reinforcement varies along the length of the slab, the average area of longitudinal reinforcement may be used to calculate the transformed area.

5.14.1.4.4—Age of Girder When Continuity Is Established

The minimum age of the precast girder when continuity is established should be specified in the contract documents. This age shall be used for calculating restraint moments due to creep and shrinkage. If no age is specified, a reasonable, but conservative estimate of the time continuity is established shall be used for all calculations of restraint moments.

The following simplification may be applied if acceptable to the Owner and if the contract documents require a minimum girder age of at least 90 days when continuity is established:

C5.14.1.4.4

Analytical studies show that the age of the precast girder when continuity is established is an important factor in the development of restraint moments (Mirmiran et al., 2001). According to analysis, establishing continuity when girders are young causes larger positive moments to develop. Therefore, if no minimum girder age for continuity is specified, the earliest reasonable age must be used. Results from surveys of practice (Miller et al., 2004) show a wide variation in girder ages at which continuity is established. An age of 7 days was reported to be a realistic minimum. However, the use of 7 days as the age of girders when continuity is established results in a

- Positive restraint moments caused by girder creep and shrinkage and deck slab shrinkage may be taken to be zero.
- Computation of restraint moments shall not be required.
- A positive moment connection shall be provided with a factored resistance, ϕMn , not less than $1.2M_{cr}$, as specified in Article 5.14.1.4.9.

For other ages at continuity, the age-related design parameters should be determined from the literature, approved by the Owner, and documented in the contract documents.

5.14.1.4.5—Degree of Continuity at Various Limit States

Both a positive and negative moment connection, as specified in Articles 5.14.1.4.8 and 5.14.1.4.9, are required for all continuity diaphragms, regardless of the degree of continuity as defined in this Article.

The connection between precast girders at a continuity diaphragm shall be considered fully effective if either of the following are satisfied:

- The calculated stress at the bottom of the continuity diaphragm for the combination of superimposed permanent loads, settlement, creep, shrinkage, 50 percent live load and temperature gradient, if applicable, is compressive.
- The contract documents require that the age of the precast girders shall be at least 90 days when continuity is established and the design simplifications of Article 5.14.1.4.4 are used.

large positive restraint moment. Therefore, a specified minimum girder age at continuity of at least 28 days is strongly recommended.

If girders are 90 days or older when continuity is established, the provisions of Article 5.4.2.3 predict that approximately 60 percent of the creep and 70 percent of the shrinkage in the girders, which could cause positive moments, has already occurred prior to establishing continuity. The Owner may allow the use of k_{id} in Eq. 5.4.2.3.2-5 set at 0.7 to determine the time at which continuity can be established and, therefore, utilize the 90-day provisions of this Article. Since most of the creep and shrinkage in the girder has already occurred before continuity is established, the potential development of time-dependent positive moments is limited. Differential shrinkage between the deck and the girders, to the extent to which it actually occurs (refer to Article C5.14.1.4.2) would also tend to limit positive moment development.

Even if the girders are 90 days old or older when continuity is established, some positive moment may develop at the connection and some cracking may occur. Research (Miller et al., 2004) has shown that if the connection is designed with a capacity of $1.2M_{cr}$, the connection can tolerate this cracking without appreciable loss of continuity.

This provision provides a simplified approach to design of precast girder bridges made continuous that eliminates the need to evaluate restraint moments. Some states allow design methods where restraint moments are not evaluated when continuity is established when girders are older than a specified age. These design methods have been used for many years with good success. However, an Owner may require the computation of restraint moments for all girder ages.

C5.14.1.4.5

A fully effective joint at a continuity diaphragm is a joint that is capable of full moment transfer between spans, resulting in the structure behaving as a continuous structure.

In some cases, especially when continuity is established at an early girder age, continuing upward cambering of the girders due to creep may cause cracking at the bottom of the continuity diaphragm (Mirmiran et al., 2001). Analysis and tests indicate that such cracking may cause the structure to act as a series of simply supported spans when resisting some portion of the permanent or live loads applied after continuity is established, however, this condition only occurs when the cracking is severe and the positive moment connection is near failure (Miller et al., 2004). Where this occurs, the connections at the continuity diaphragm are partially effective.

If the connection between precast girders at a continuity diaphragm does not satisfy these requirements, the joint shall be considered partially effective.

Superstructures with fully effective connections at interior supports may be designed as fully continuous structures for loads applied after continuity is established.

Superstructures with partially effective connections at interior supports shall be designed as continuous structures for loads applied after continuity is established for strength limit states only.

Gross composite girder section properties, ignoring any deck cracking, may be used for analysis as specified in Article 4.5.2.2.

If the negative moment resistance of the section at an interior support is less than the total amount required, the positive design moments in the adjacent spans shall be increased appropriately for each limit state investigated.

5.14.1.4.6—Service Limit State

Simple-span precast girders made continuous shall be designed to satisfy service limit state stress limits given in Article 5.9.4. For service load combinations that involve traffic loading, tensile stresses in prestressed members shall be investigated using the Service III load combination specified in Table 3.4.1-1.

At the service limit state after losses, when tensile stresses develop at the top of the girders near interior supports, the tensile stress limits specified in Table 5.9.4.1.2-1 for other than segmentally constructed bridges shall apply. The specified compressive strength of the girder concrete, f'_c , shall be substituted for f'_{ci} in the stress limit equations. The Service III load combination shall be used to compute tensile stresses for these locations.

Alternatively, the top of the precast girders at interior supports may be designed as reinforced concrete members at the strength limit state. In this case, the stress limits for the service limit state shall not apply to this region of the precast girder.

Theoretically, the portion of the permanent or live loads required to close the cracks would be applied to a simply supported span, neglecting continuity. The remainder of the load would then be applied to the continuous span, assuming full continuity. However, in cases where the portion of the live load required to close the crack is less than 50 percent of the live load, placing part of the load on simple spans and placing the remainder on the continuous bridge results in only a small change in total stresses at critical sections due to all loads. Tests have shown that the connections can tolerate some positive moment cracking and remain continuous (Miller et. al., 2004). Therefore, if the conditions of the first bullet point are satisfied, it is reasonable to design the member as continuous for the entire load placed on the structure after continuity is established.

The second bullet follows from the requirements of Article 5.14.1.4.4 where restraint moments may be neglected if continuity is established when the age of the precast girder is at least 90 days. Without positive moment, the potential cracks in the continuity diaphragm would not form and the connection would be fully effective.

Partially effective construction joints are designed by applying the portion of the permanent and live loads applied after continuity is established to a simple span (neglecting continuity). Only the portion of the loads required to close the assumed cracks is applied. The remainder of the permanent and live loads would then be applied to the continuous span. The load required to close the crack can be taken as the load causing zero tension at the bottom of the continuity diaphragm. Such analysis may be avoided if the contract documents require the age of the girder at continuity to be at least 90 days.

C5.14.1.4.6

Tensile stresses under service limit state loadings may occur at the top of the girder near interior supports. This region of the girder is not a precompressed tensile zone, so there is not an applicable tensile stress limit in Table 5.9.4.2.2-1. Furthermore, the tensile zone is close to the end of the girder, so adding or debonding pretensioned strands has little effect in reducing the tensile stresses. Therefore, the limits specified for temporary stresses before losses have been used to address this condition, with modification to use the specified concrete strength. This provision provides some relief for the potentially high tensile stresses that may develop at the ends of girders because of negative service load moments.

This option allows the top of the girder at the interior support to be designed as a reinforced concrete element using the strength limit state rather than a prestressed concrete element using the service limit state.

The deck slab is not a prestressed element. Therefore, the tensile stress limits do not apply. It has

A cast-in-place composite deck slab shall not be subject to the tensile stress limits for the service limit state after losses specified in Table 5.9.4.2.2-1.

5.14.1.4.7—Strength Limit State

The connections between precast girders and a continuity diaphragm shall be designed for the strength limit state.

The reinforcement in the deck slab shall be proportioned to resist negative design moments at the strength limit state.

5.14.1.4.8—Negative Moment Connections

The reinforcement in a cast-in-place, composite deck slab in a multi-span precast girder bridge made continuous shall be proportioned to resist negative design moments at the strength limit state.

Longitudinal reinforcement used for the negative moment connection over an interior pier shall be anchored in regions of the slab that are in compression at strength limit states and shall satisfy the requirements of Article 5.11.1.2.3. The termination of this reinforcement shall be staggered. All longitudinal reinforcement in the deck slab may be used for the negative moment connection.

Negative moment connections between precast girders into or across the continuity diaphragm shall satisfy the requirements of Article 5.11.5. These connections shall be permitted where the bridge is designed with a composite deck slab and shall be required where the bridge is designed without a composite deck slab. Additional connection details shall be permitted if the strength and performance of these connections is verified by analysis or testing.

The requirements of Article 5.7.3 shall apply to the reinforcement in the deck slab and at negative moment connections at continuity diaphragms.

5.14.1.4.9—Positive Moment Connections

5.14.1.4.9a—General

Positive moment connections at continuity diaphragms shall be made with reinforcement developed into both the girder and continuity diaphragm. Three types of connections shall be permitted:

- Mild reinforcement embedded in the precast girders and developed into the continuity diaphragm.
- Pretensioning strands extended beyond the end of the girder and anchored into the continuity diaphragm. These strands shall not be debonded at the end of the girder.

been customary to apply the compressive stress limits to the deck slab.

C5.14.1.4.7

The continuity diaphragm is not prestressed concrete so the stress limits for the service limit state do not apply. Connections to it are therefore designed using provisions for reinforced concrete elements.

C5.14.1.4.8

Research at PCA (Kaar et al., 1961) and years of experience show that the reinforcement in a composite deck slab can be proportioned to resist negative design moments in a continuous bridge.

Limited tests on continuous model and full size structural components indicate that, unless the reinforcement is anchored in a compressive zone, the effectiveness becomes questionable at the strength limit state (Priestly, 1993). The termination of the longitudinal deck slab reinforcement is staggered to minimize potential deck cracking by distributing local force effects.

A negative moment connection between precast girders and the continuity diaphragm is not typically provided, because the deck slab reinforcement is usually proportioned to resist the negative design moments. However, research (Ma et al., 1998) suggests that mechanical connections between the tops of girders may also be used for negative moment connections, especially when continuity is established prior to placement of the deck slab. If a composite deck slab is not used on the bridge, a negative moment connection between girders is required to obtain continuity. Mechanical reinforcement splices have been successfully used to provide a negative moment connection between box beam bridges that do not have a composite deck slab.

C5.14.1.4.9a

Positive moment connections improve the structural integrity of a bridge, increasing its ability to resist extreme event and unanticipated loadings. Therefore, it is recommended that positive moment connections be provided in all bridges detailed as continuous for live load.

Both embedded bar and extended strand connections have been used successfully to provide positive moment resistance. Test results (Miller et al., 2004) indicate that connections using the two types of reinforcement perform similarly under both static and fatigue loads and both have adequate strength to resist the applied moments.

- Any connection detail shown by analysis, testing or as approved by the Bridge Owner to provide adequate positive moment resistance.

Additional requirements for connections made using each type of reinforcement are given in subsequent Articles.

The critical section for the development of positive moment reinforcement into the continuity diaphragm shall be taken at the face of the girder. The critical section for the development of positive moment reinforcement into the precast girder shall consider conditions in the girder as specified in this Article for the type of reinforcement used.

The requirements of Article 5.7.3, except Article 5.7.3.3.2, shall apply to the reinforcement at positive moment connections at continuity diaphragms. This reinforcement shall be proportioned to resist the larger of the following, except when using the design simplifications of Article 5.14.1.4.4:

- Factored positive restraint moment, or
- $0.6M_{cr}$

The cracking moment M_{cr} shall be computed using Eq. 5.7.3.6.2-2 with the gross composite section properties for the girder and the effective width of composite deck slab, if any, and the material properties of the concrete in the continuity diaphragm.

The precast girders shall be designed for any positive restraint moments that are used in design. Near the ends of girders, the reduced effect of prestress within the transfer length shall be considered.

*5.14.1.4.9b—Positive Moment Connection
Using Mild Reinforcement*

The anchorage of mild reinforcement used for positive moment connections shall satisfy the requirements of Article 5.11 and the additional requirements of this Article. Where positive moment reinforcement is added between pretensioned strands, consolidation of concrete and bond of reinforcement shall be considered.

The critical section for the development of positive moment reinforcement into the precast girder shall consider conditions in the girder. The reinforcement shall be developed beyond the inside edge of the bearing area. The reinforcement shall also be detailed so that, for strands considered in resisting positive moments within the end of the girder, debonding of strands does not terminate within the development length.

Where multiple bars are used for a positive moment connection, the termination of the reinforcement shall be staggered in pairs symmetrical about the centerline of the precast girder.

Analytical studies (Mirmiran et. al., 2001) suggest that a minimum amount of reinforcement, corresponding to a capacity of $0.6 M_{cr}$ is needed to develop adequate resistance to positive restraint moments. These same studies show that a positive moment connection with a capacity greater than $1.2M_{cr}$ provides only minor improvement in continuity behavior over a connection with a capacity of $1.2M_{cr}$. Therefore, it is recommended that the positive moment capacity of the connection not exceed $1.2M_{cr}$. If the computed positive moment exceeds $1.2M_{cr}$, the section should be modified or steps should be taken to reduce the positive moment.

The cracking moment M_{cr} is the moment that causes cracking in the continuity diaphragm. Since the continuity diaphragm is not a prestressed concrete section, the equation for computing the cracking moment for a reinforced section is used. The diaphragm is generally cast with the deck concrete, so the section properties are computed using uniform concrete properties, so the deck width is not transformed.

Article 5.7.3.3.2 specifies a minimum capacity for all flexural sections. This is to prevent sudden collapse at the formation of the first crack. However, the positive moment connection that is being discussed here is not intended to resist applied live loads. Even if the positive moment connection were to fail completely, the system may, at worst, become a series of simple spans. Therefore, the minimum reinforcement requirement of Article 5.7.3.3.2 does not apply. Allowing positive moment connections with lower quantities of reinforcement will relieve congestion in continuity diaphragms.

C5.14.1.4.9b

The positive moment connection is designed to utilize the yield strength of the reinforcement. Therefore, the connection must be detailed to provide full development of the reinforcement. If the reinforcement cannot be detailed for full development, the connection may be designed using a reduced stress in the reinforcement.

Potential cracks are more likely to form in the precast girder at the inside edge of the bearing area and locations of termination of debonding. Since cracking within the development length reduces the effectiveness of the development, the reinforcement should be detailed to avoid this condition. It is recommended that reinforcement be developed beyond the location where a crack radiating from the inside edge of the bearing may cross the reinforcement.

The termination of the positive moment reinforcement is staggered to reduce the potential for cracking at the ends of the bars.

5.14.1.4.9c—Positive Moment Connection
Using Prestressing Strand

Pretensioning strands that are not debonded at the end of the girder may be extended into the continuity diaphragm as positive moment reinforcement. The extended strands shall be anchored into the diaphragm by bending the strands into a 90-degree hook or by providing a development length as specified in Article 5.11.4.

The stress in the strands used for design, as a function of the total length of the strand, shall not exceed:

$$f_{psl} = \frac{(\ell_{dsh} - 8)}{0.228} \quad (5.14.1.4.9c-1)$$

$$f_{pul} = \frac{(\ell_{dsh} - 8)}{0.163} \quad (5.14.1.4.9c-2)$$

where:

- ℓ_{dsh} = total length of extended strand (in.)
- f_{psl} = stress in the strand at the service limit state
Cracked section shall be assumed (ksi)
- f_{pul} = stress in the strand at the strength limit state
(ksi)

Strands shall project at least 8.0 in. from the face of the girder before they are bent.

5.14.1.4.9d—Details of Positive Moment
Connection

Positive moment reinforcement shall be placed in a pattern that is symmetrical, or as nearly symmetrical as possible, about the centerline of the cross-section.

Fabrication and erection issues shall be considered in the detailing of positive moment reinforcement in the continuity diaphragm. Reinforcement from opposing girders shall be detailed to mesh during erection without significant conflicts. Reinforcement shall be detailed to enable placement of anchor bars and other reinforcement in the continuity diaphragm.

Strands that are debonded or shielded at the end of a member may not be used as reinforcement for the positive moment connection. There are no requirements for development of the strand into the girder because the strands run continuously through the precast girder.

Eqs. 5.14.1.4.9c-1 and 5.14.1.4.9c-2 were developed for 0.5-in. strand by Salmons et al. (1980). These are for prestressing strand extended from the end of the girder and given 90-degree hooks. Other equations are also available to estimate stress in bent strands (Noppakunwijai et al., 2002).

C5.14.1.4.9d

Tests (Miller et al., 2004) suggest that reinforcement patterns that have significant asymmetry may result in unequal bar stresses that can be detrimental to the performance of the positive moment connection.

With some girder shapes, it may not be possible to install prebent hooked bars without the hook tails interfering with the formwork. In such cases, a straight bar may be embedded and then bent after the girder is fabricated. Such bending is generally accomplished without heating and the bend must be smooth with a minimum bend diameter conforming to the requirements of Table 5.10.2.3-1. If the Engineer allows the reinforcement to be bent after the girder is fabricated, the contract documents shall indicate that field bending is permissible and shall provide requirements for such bending. Since requirements regarding field bending may vary, the preferences of the Owner should be considered.

Hairpin bars (a bar with a 180-degree bend with both legs developed into the precast girder) have been used for positive moment connections to eliminate the need for post-fabrication bending of the reinforcement and reduce congestion in the continuity diaphragm.

5.14.1.4.10—Continuity Diaphragms

The design of continuity diaphragms at interior supports may be based on the strength of the concrete in the precast girders.

Precast girders may be embedded into continuity diaphragms.

If horizontal diaphragm reinforcement is passed through holes in the precast beam or is attached to the precast element using mechanical connectors, the end precast element shall be designed to resist positive moments caused by superimposed dead loads, live loads, creep and shrinkage of the girders, shrinkage of the deck slab, and temperature effects. Design of the end of the girder shall account for the reduced effect of prestress within the transfer length.

Where ends of girders are not directly opposite each other across a continuity diaphragm, the diaphragm must be designed to transfer forces between girders. Continuity diaphragms shall also be designed for situations where an angle change occurs between opposing girders.

C5.14.1.4.10

The use of the increased concrete strength is permitted because the continuity diaphragm concrete between girder ends is confined by the girders and by the continuity diaphragm extending beyond the girders. It is recommended that this provision be applied only to conditions where the portion of the continuity diaphragm that is in compression is confined between ends of precast girders.

The width of the continuity diaphragm must be large enough to provide the required embedment for the development of the positive moment reinforcement into the diaphragm. An anchor bar with a diameter equal to or greater than the diameter of the positive moment reinforcement may be placed in the corner of a 90-degree hook or inside the loop of a 180-degree hook bar to improve the effectiveness of the anchorage of the reinforcement.

Several construction sequences have been successfully used for the construction of bridges with precast girders made continuous. When determining the construction sequence, the Engineer should consider the effect of girder rotations and restraint as the deck slab concrete is being placed.

Test results (Miller et al., 2004) have shown that embedding precast girders 6.0 in. into continuity diaphragms improves the performance of positive moment connections. The observed stresses in the positive moment reinforcement in the continuity diaphragm were reduced compared to connections without girder embedment.

The connection between precast girders and the continuity diaphragm may be enhanced by passing horizontal reinforcement through holes in the precast beam or attaching the reinforcement to the beam by embedded connectors. Test results (Miller et al., 2004; Salmons, 1980) show that such reinforcement stiffens the connection. The use of such mechanical connections requires that the end of the girder be embedded into the continuity diaphragm. Tests of continuity diaphragms without mechanical connections between the girder and diaphragm show the failure of connection occurs by the beam end pulling out of the diaphragm with all of the damage occurring in the diaphragm. Tests of connections with horizontal bars show that cracks may form in the end of the precast girder outside the continuity diaphragm if the connection is subjected to a significant positive moment. Such cracking in the end region of the girder may not be desirable.

A method such as given in Article 5.6.3 may be used to design a continuity diaphragm for these conditions.

5.14.1.5—Cast-in-Place Girders and Box and T-Beams

5.14.1.5.1—Flange and Web Thickness

5.14.1.5.1a—Top Flange

The thickness of top flanges serving as deck slabs shall be:

- As determined in Section 9;
- As required for anchorage and cover for transverse prestressing, if used; and
- Not less than the clear span between fillets, haunches, or webs divided by 20, unless transverse ribs at a spacing equal to the clear span are used or transverse prestressing is provided.

5.14.1.5.1b—Bottom Flange

The bottom flange thickness shall be not less than:

- 5.5 in.;
- the distance between fillets or webs of nonprestressed girders and beams divided by 16; or
- the clear span between fillets, haunches, or webs for prestressed girders divided by 30, unless transverse ribs at a spacing equal to the clear span are used.

5.14.1.5.1c—Web

The thickness of webs shall be determined by requirements for shear, torsion, concrete cover, and placement of concrete.

Changes in girder web thickness shall be tapered for a minimum distance of 12.0 times the difference in web thickness.

5.14.1.5.2—Reinforcement

5.14.1.5.2a—Deck Slab Reinforcement Cast-in-Place in T-Beams and Box Girders

The reinforcement in the deck slab of cast-in-place T-beams and box girders may be determined by either the traditional or the empirical design methods specified in Section 9.

Where the deck slab does not extend beyond the exterior web, at least one-third of the bottom layer of the transverse reinforcement in the deck slab shall be extended into the exterior face of the outside web and anchored by a standard 90-degree hook. If the slab

C5.14.1.5.1c

For adequate field placement and consolidation of concrete, a minimum web thickness of 8.0 in. is needed for webs without prestressing ducts; 12.0 in. is needed for webs with only longitudinal or vertical ducts; and 15.0 in. is needed for webs with both longitudinal and vertical ducts. For girders over about 8.0 ft in depth, these dimensions should be increased to compensate for the increased difficulty of concrete placement.

extends beyond the exterior web, at least one-third of the bottom layer of the transverse reinforcement shall be extended into the slab overhang and shall have an anchorage beyond the exterior face of the web not less in resistance than that provided by a standard hook.

5.14.1.5.2b—Bottom Slab Reinforcement in Cast-in-Place Box Girders

A uniformly distributed reinforcement of 0.4 percent of the flange area shall be placed in the bottom slab parallel to the girder span, either in single or double layers. The spacing of such reinforcement shall not exceed 18.0 in.

A uniformly distributed reinforcement of 0.5 percent of the cross-sectional area of the slab, based on the least slab thickness, shall be placed in the bottom slab transverse to the girder span. Such reinforcement shall be distributed over both surfaces with a maximum spacing of 18.0 in. All transverse reinforcement in the bottom slab shall be extended to the exterior face of the outside web in each group and shall be anchored by a standard 90-degree hook.

5.14.2—Segmental Construction

5.14.2.1—General

The requirements specified herein shall supplement the requirements of other sections of these Specifications for concrete structures designed to be constructed by the segmental method.

The provisions herein shall apply only to segmental construction using normal-weight concrete.

The method of construction assumed for the design shall be shown in the contract documents. Temporary supports required prior to the time the structure, or component thereof, is capable of supporting itself and subsequently applied loads, shall also be shown in the contract documents.

C5.14.1.5.2b

This provision is intended to apply to both reinforced and prestressed boxes.

C5.14.2.1

For segmental construction, superstructures of single or multiple box sections are generally used. Segmental construction includes construction by free cantilever, span-by-span, or incremental launching methods using either precast or cast-in-place concrete segments which are joined to produce either continuous or simple spans.

Bridges utilizing beam-type sections may also be constructed using segmental construction techniques. Such bridges, which are referred to as spliced precast girder bridges in these Specifications, are considered to be a special case of conventional concrete bridges. The design of such bridges is covered in Article 5.14.1.3.

The span length of bridges considered by these Specifications ranges to 800 ft. Bridges supported by stay cables are not specifically covered in this Article, although many of the specification provisions are also applicable to them.

Lightweight concrete has been infrequently used for segmental bridge construction. Provision for the use of lightweight aggregates represents a significant complication of both design and construction specifications. Given this complication and questions concerning economic benefit, use of lightweight aggregates for segmental bridges is not explicitly covered.

The method of construction and any required temporary support is of paramount importance in the design of segmental concrete bridges. Such considerations often govern final conditions in the selection of section dimensions and reinforcing and/or prestressing.

The contract documents shall indicate alternative methods of construction permitted and the Contractor's responsibilities if such methods are chosen. Any changes by the Contractor in the construction method or in the design shall comply with the requirements of Article 5.14.2.5.

5.14.2.2—Analysis of Segmental Bridges

5.14.2.2.1—General

The analysis of segmentally constructed bridges shall conform to the requirements of Section 4 and those specified herein.

5.14.2.2.2—Construction Analysis

For the analysis of the structure during the construction stage, the construction load combinations, stresses, and stability considerations shall be as specified in Article 5.14.2.3.

5.14.2.2.3—Analysis of the Final Structural System

The final structural system shall be analyzed for redistribution of construction-stage force effects due to internal deformations and changes in support and restraint conditions, including accumulated locked-in force effects resulting from the construction process.

Joints in segmental girders made continuous by unbonded post-tensioning steel shall be investigated for the simultaneous effect of axial force, moment, and shear that may occur at a joint. These force effects, the opening of the joint, and the remaining contact surface between the components shall be determined by global

For segmentally constructed bridges, designs should and generally do allow the Contractor some latitude in choice of construction methods. To ensure that the design features and details to be used are compatible with the proposed construction method, it is essential that the Contractor be required to prepare working drawings and calculations based on his choice of methods for review and approval by the Engineer before work begins.

C5.14.2.2.3

Results of analyses of a segmental concrete superstructure that has values of creep coefficient of 1, 2, and 3 and that uses both the ACI 209 and CEB-FIP creep models, have been published (AASHTO, 1989). Final stresses were essentially unchanged for creep coefficients of 1, 2, and 3 using the ACI 209 creep provisions. Although the analyses with the CEB-FIP creep model show somewhat more variation in final stresses, the range of stresses is still small for a large variation in creep coefficients. The selection of the ACI 209 or CEB-FIP creep model has a larger impact on the final stress values than the creep coefficients. However, it is doubtful that the full range of stresses reflected in the six analyses described would be of practical significance with respect to the performance of the structure.

Because the creep coefficient will be known or determined with reasonable accuracy under the requirements of these Specifications, analysis using a single value of the creep coefficient is considered satisfactory, and use of low and high values of the creep coefficient in analysis is generally considered unnecessary. This is not intended to imply that creep values should not be determined accurately because these values do have a significant impact on the prestress losses, deflections, and axial shortening of the structure.

Joining components with unbonded tendons may permit the opening of unreinforced joints at or close to strength limit states. The Designer should review the structural consequences of such joint openings.

consideration of strain and deformation. Shear shall be assumed to be transmitted through the contact area only.

5.14.2.3—Design

5.14.2.3.1—Loads

In addition to the loads specified in Section 3, the construction loads specified in Articles 5.14.2.3.2 through 5.14.2.3.4 shall be considered.

5.14.2.3.2—Construction Loads

Construction loads and conditions that are assumed in the design and that determine section dimensions, camber, and reinforcing and/or prestressing requirements shall be shown as maxima allowed in the contract documents. In addition to erection loads, any required temporary supports or restraints shall be defined as to magnitude or included as part of the design. The acceptable closure forces due to misalignment corrections shall be stated. Due allowance shall be made for all effects of any changes of the static structural scheme during construction and the application, changes, or removal of the assumed temporary supports of special equipment, taking into account residual force effects, deformations, and any strain-induced effects.

The following construction loads shall be considered:

<i>DC</i>	=	weight of the supported structure (kip)
<i>DIFF</i>	=	differential load: applicable only to balanced cantilever construction taken as two percent of the dead load applied to one cantilever (kip)
<i>DW</i>	=	superimposed dead load (kip) or (klf)
<i>CLL</i>	=	distributed construction live load: an allowance for miscellaneous items of plant, machinery, and other equipment, apart from the major specialized erection equipment; taken as 0.010 ksf of deck area; in cantilever construction, this load is taken as 0.010 ksf on one cantilever and 0.005 ksf on the other; for bridges built by incremental launching, this load may be neglected (ksf)
<i>CEQ</i>	=	specialized construction equipment: the load from segment or material delivery trucks, or both, and any special equipment, including a formtraveler launching gantry, beam and winch, truss, or similar major auxiliary structure and the maximum loads applied to the structure by the equipment during the lifting of segments (kip)
<i>IE</i>	=	dynamic load from equipment: determined according to the type of machinery anticipated (kip)

C5.14.2.3.2

Construction loads comprise all loadings arising from the Designer's anticipated system of temporary supporting works and/or special erection equipment to be used in accordance with the assumed construction sequence and schedule.

Construction loads and conditions frequently determine section dimensions and reinforcing and/or prestressing requirements in segmentally constructed bridges. It is important that the Designer show these assumed conditions in the contract documents.

These provisions are not meant to be limitations on the Contractor as to the means that may be used for construction. Controls are essential to prevent damage to the structure during construction and to ensure adequacy of the completed structure. It is also essential for the bidders to be able to determine if their equipment and proposed construction methods can be used without modifying the design or the equipment.

The contract documents should require the Engineer's approval of any changes in the assumed erection loadings or conditions.

Construction loads may be imposed on opposing cantilever ends by use of the formtraveler, diagonal alignment bars, a jacking tower, or external weights. Cooling of one cantilever with water has also been used to provide adjustment of misalignment. Any misalignment of interior cantilevers should be corrected at both ends before constructing either closure. The frame connecting cantilever ends at closure pours should be detailed to prevent differential rotation between cantilevers until the final structural connection is complete. The magnitude of closure forces should not induce stresses in the structure in excess of those tabulated in Table 5.14.2.3.3-1.

The load *DIFF* allows for possible variations in cross-section weight due to construction irregularities.

For very gradual lifting of segments, where the load involves small dynamic effects, the dynamic load *IE* may be taken as ten percent of the lifted weight.

The following information is based on some past experience and should be considered very preliminary. Formtravelers for cast-in-place segmental construction for a typical two-lane bridge with 15.0 to 16.0 ft segments may be estimated to weigh 160 to 180 kips.

<i>CLE</i>	= longitudinal construction equipment load: the longitudinal load from the construction equipment (kip)	Weight of formtravelers for wider double-celled box sections may range up to approximately 280 kips. Consultation with contractors or subcontractors experienced in free cantilever construction, with respect to the specific bridge geometry under consideration, is recommended to obtain a design value for formtraveler weight.
<i>U</i>	= segment unbalance: the effect of any out-of-balance segments or other unusual conditions as applicable; applies primarily to balanced cantilever construction but may be extended to include any unusual lifting sequence that may not be a primary feature of the generic construction system (kip)	
<i>WS</i>	= horizontal wind load on structures in accordance with the provisions of Section 3 (ksf)	
<i>WE</i>	= horizontal wind load on equipment; taken as 0.1 ksf of exposed surface (ksf)	
<i>WUP</i>	= wind uplift on cantilever: 0.005 ksf of deck area for balanced cantilever construction applied to one side only, unless an analysis of site conditions or structure configuration indicates otherwise (ksf)	
<i>A</i>	= static weight of precast segment being handled (kip)	
<i>AI</i>	= dynamic response due to accidental release or application of a precast segment load or other sudden application of an otherwise static load to be added to the dead load; taken as 100 percent of load <i>A</i> (kip)	
<i>CR</i>	= creep effects in accordance with Article 5.14.2.3.6	
<i>SH</i>	= shrinkage in accordance with Article 5.14.2.3.6	
<i>T</i>	= thermal: the sum of the effects due to uniform temperature variation (<i>TU</i>) and temperature gradients (<i>TG</i>) (°F)	

5.14.2.3.3—Construction Load Combinations at the Service Limit State

Flexural tension and principal tension stresses shall be determined at service limit states as specified in Table 5.14.2.3.3-1, for which the following notes apply:

- Note 1: equipment not working,
- Note 2: normal erection, and
- Note 3: moving equipment.

Stress limits shall conform to Article 5.9.4.

The distribution and application of the individual erection loads appropriate to a construction phase shall be selected to produce the most unfavorable effects. The construction load compressive stress in concrete shall not exceed $0.50f'_c$, where f'_c is the compressive strength at the time of load application.

C5.14.2.3.3

The stresses in Table 5.14.2.3.3-1 limit construction load stresses to less than the modulus of rupture of the concrete for structures with internal tendons and Type A joints. The construction load stresses should not, therefore, generate any cracking.

Tensile stresses in concrete due to construction loads shall not exceed the values specified in Table 5.14.2.3.3-1, except for structures with less than 60 percent of their tendon capacity provided by internal tendons, in which case the tensile stresses shall not exceed $0.095\sqrt{f'_c}$. The requirements of Table 5.14.2.3.3-1 shall apply to vertically post-tensioned substructures. The requirements of Table 5.14.2.3.3-1 shall not be applied to construction of cast-in-place substructures supporting segmental superstructures.

Table 5.14.2.3.3-1—Load Factors and Tensile Stress Limits for Construction Load Combinations

Load Combination	LOAD FACTORS														STRESS LIMITS				See Note					
	Dead Load			Live Load			Wind Load			Other Loads					Earth Loads	Flexural Tension		Principal Tension						
	<i>D</i>	<i>C</i>	<i>DIFF</i>	<i>U</i>	<i>CE</i>	<i>CL</i>	<i>IE</i>	<i>WS</i>	<i>WUP</i>	<i>WE</i>	<i>CR</i>	<i>SH</i>	<i>TU</i>	<i>TG</i>	<i>W</i>	<i>A</i>	<i>EH</i>	<i>EV</i>		<i>ES</i>	Excluding “Other Loads”	Including “Other Loads”	Excluding “Other Loads”	Including “Other Loads”
a	1.0	1.0	0.0	1.0	1.0	0.0	0.0	0.0	0.0	1.0	1.0	1.0	γ_{TG}	1.0	1.0					$0.190\sqrt{f'_c}$	$0.220\sqrt{f'_c}$	$0.110\sqrt{f'_c}$	$0.126\sqrt{f'_c}$	—
b	1.0	0.0	1.0	1.0	1.0	0.0	0.0	0.0	0.0	1.0	1.0	1.0	γ_{TG}	1.0	1.0					$0.190\sqrt{f'_c}$	$0.220\sqrt{f'_c}$	$0.110\sqrt{f'_c}$	$0.126\sqrt{f'_c}$	—
c	1.0	1.0	0.0	0.0	0.0	0.0	0.7	0.7	0.0	1.0	1.0	1.0	γ_{TG}	1.0	1.0					$0.190\sqrt{f'_c}$	$0.220\sqrt{f'_c}$	$0.110\sqrt{f'_c}$	$0.126\sqrt{f'_c}$	—
d	1.0	1.0	0.0	1.0	0.0	0.0	0.7	1.0	0.7	1.0	1.0	1.0	γ_{TG}	1.0	1.0					$0.190\sqrt{f'_c}$	$0.220\sqrt{f'_c}$	$0.110\sqrt{f'_c}$	$0.126\sqrt{f'_c}$	1
e	1.0	0.0	1.0	1.0	1.0	0.0	0.3	0.0	0.3	1.0	1.0	1.0	γ_{TG}	1.0	1.0					$0.190\sqrt{f'_c}$	$0.220\sqrt{f'_c}$	$0.110\sqrt{f'_c}$	$0.126\sqrt{f'_c}$	2
f	1.0	0.0	0.0	1.0	1.0	1.0	0.3	0.0	0.3	1.0	1.0	1.0	γ_{TG}	1.0	1.0					$0.190\sqrt{f'_c}$	$0.220\sqrt{f'_c}$	$0.110\sqrt{f'_c}$	$0.126\sqrt{f'_c}$	3

5.14.2.3.4—Construction Load Combinations at Strength Limit States

The minimum factored resistance of a component shall be determined using resistance factors specified in Article 5.5.4.2 and the load combinations specified in Articles 5.14.2.3.4a and 5.14.2.3.4b.

5.14.2.3.4a—Superstructures

- For maximum force effects:

$$\Sigma\gamma Q = 1.1(DC + DIFF) + 1.3(CEQ + CLL) + A + AI \quad (5.14.2.3.4a-1)$$

- For minimum force effects:

$$\Sigma\gamma Q = DC + CEQ + A + AI \quad (5.14.2.3.4a-2)$$

5.14.2.3.4b—Substructures

The Strength I, III, and V load combinations from Table 3.4.1-1 shall apply. The loads *DIFF* and *CEQ* shall be included and factored with γ_{DC} . The load *WUP* shall be included and factored with γ_{WS} . The loads *CLL* and *WE* shall be included and used in place of *LL* and *WL*, respectively.

Construction strength load combinations shall also include load combinations from Eqs. 5.14.2.3.4a-1 and 5.14.2.3.4a-2. The dynamic response or dynamic allowance (*AI*) shall be applied to substructure elements above the drilled shaft or footing including the column to foundation connection.

5.14.2.3.5—Thermal Effects During Construction

Thermal effects that may occur during the construction of the bridge shall be considered.

The temperature setting variations for bearings and expansion joints shall be stated in the contract documents.

5.14.2.3.6—Creep and Shrinkage

Creep coefficient $\Psi(t, t_i)$ shall be determined in accordance with Article 5.4.2.3 or by comprehensive tests. Stresses shall be determined for redistribution of restraint stresses developed by creep and shrinkage that are based on the assumed construction schedule as stated in the contract documents.

For determining the final post-tensioning forces, prestress losses shall be calculated for the construction schedule stated in the contract documents.

C5.14.2.3.4a

Eqs. 5.14.2.3.4a-1 and 5.14.2.3.4a-2 are strength checks for accident conditions only, and are not intended as alternative strength criteria in lieu of the service stress checks in Table 5.14.2.3.3-1.

C5.14.2.3.4b

Substructures for post-tensioned segmental superstructures should be reviewed for construction stage demands using the design basis for the strength limit state consistent with reinforced concrete design. Conventionally reinforced segmental superstructures, such as arches, should be similarly reviewed. A reduced load factor may be appropriate for the loads *CLL* and *WE* if the construction equipment is well defined during design.

C5.14.2.3.5

The provisions of Article 3.12 relate to annual temperature variations and should be adjusted for the actual duration of superstructure construction as well as for local conditions.

Transverse analysis for the effects of differential temperature outside and inside box girder sections is not generally considered necessary. However, such an analysis may be necessary for relatively shallow bridges with thick webs. In that case, a $\pm 10.0^\circ\text{F}$ temperature differential is recommended.

C5.14.2.3.6

A variety of computer programs and analytical procedures have been published to determine creep and shrinkage effects in segmental concrete bridges.

Creep strains and prestress losses that occur after closure of the structure cause a redistribution of the force effects.

For permanent loads, the behavior of segmental bridges after closure may be approximated by use of an effective modulus of elasticity, E_{eff} , which may be calculated as:

$$E_{eff} = \frac{E_c}{\Psi(t, t_i) + 1} \quad (C5.14.2.3.6-1)$$

where:

$\Psi(t, t_i)$ = the creep coefficient

A comprehensive series of equations for evaluating the time-related effects of creep and shrinkage is presented in the ACI Committee 209 report, *Prediction of Creep, Shrinkage and Temperature Effects in Concrete Structures* (ACI, 1982). A procedure based on graphical values for creep and shrinkage parameters is presented in the *CEB-FIP Model Code* (CEB, 1990). Comparisons of the effects of application of the ACI and CEB provisions are presented in the Appendix, the first edition of the AASHTO Guide Specifications for Design and Construction of Segmental Concrete Bridges (AASHTO, 1989; Ketchum, 1986).

Bryant and Vadhanavikkit (1987) suggest that the ACI 209 predictions underestimate the creep and shrinkage strains for the large-scale specimens used in segmental bridges. The ACI 209 creep predictions were consistently about 65 percent of the experimental results in these tests. The report suggests modifications of the ACI 209 equations based on the size or thickness of the members.

5.14.2.3.7—Prestress Losses

The applicable provisions of Article 5.9.5 shall apply.

C5.14.2.3.7

The friction and wobble coefficients in Article 5.9.5.2.2 for galvanized duct were developed for conventional cast-in-place box girder bridges based on job-site tests of various sizes and lengths of tendons. The values are reasonably accurate for tendons comprised of 12 strands of 0.5-in. diameter in a 2.625-in. diameter galvanized metal sheathing. Tests and experience indicate that the values are conservative for larger tendons and duct diameters. However, experience with segmental concrete bridges to date has often indicated higher friction and wobble losses due to movement of ducts during concrete placement and misalignment at segment joints. For this reason, in-place friction tests are recommended at an early stage in major projects as a basis for modifying friction and wobble loss values. No reasonable values for friction and wobble coefficients can be recommended to account for gross duct misalignment problems. As a means of compensating for high friction and wobble losses or provisional post-tensioning tendons as well as for other contingencies, additional ducts are required in accordance with Article 5.14.2.3.8.

5.14.2.3.8—Provisional Post-Tensioning Ducts and Anchorages

5.14.2.3.8a—General

Provisions for adjustments of prestressing force to compensate for unexpected losses during construction or at a later time, future dead loads, and control of cracking and deflections shall be considered. Where such adjustments are deemed necessary, the requirements specified herein shall be satisfied.

5.14.2.3.8b—Bridges with Internal Ducts

For bridges with internal ducts, provisional anchorage and duct capacity for negative and positive moment tendons located symmetrically about the bridge centerline shall provide for an increase in the post-tensioning force during original construction. The total provisional force potential of both positive and negative moment anchorages and ducts shall not be less than five percent of the total positive and negative moment post-tensioning forces, respectively. Anchorages for the provisional prestressing force shall be distributed uniformly at three segment intervals along the length of the bridge.

At least one empty duct per web shall be provided. For continuous bridges, provisional positive moment ducts and anchorage capacity need not be used for 25 percent of the span length on either side of the pier supports.

Any provisional ducts not used for adjustment of the post-tensioning force shall be grouted at the same time as other ducts in the span.

5.14.2.3.8c—Provision for Future Dead Load or Deflection Adjustment

Provision shall be made for access and for anchorage attachments, pass-through openings, and deviation block attachments to permit future addition of corrosion-protected unbonded external tendons located inside the box section symmetrically about the bridge centerline for a post-tensioning force of not less than ten percent of the positive moment and negative moment post-tensioning force.

5.14.2.3.9—Plan Presentation

Contract documents shall include description of one construction method upon which the design is based. Contract drawings shall be detailed according to the provisions of *AASHTO LRFD Bridge Construction Specifications*, Section 10, "Prestressing."

C5.14.2.3.8b

Excess capacity may be provided by use of oversize ducts and oversize anchorage hardware at selected anchorage locations.

The purpose of grouting unused ducts is to prevent entrapment of water in the ducts.

C5.14.2.3.8c

This provides for future addition of internal unbonded post-tensioning tendons draped from the top of the diaphragm at piers to the intersection of the web and flange at midspan. Tendons from adjacent spans should be lapped at opposite faces of the diaphragm to provide negative moment capacity. The requirement of a force of ten percent of the positive moment and negative moment post-tensioning force is an arbitrary but reasonable value. Provision for larger amounts of post-tensioning might be developed, as necessary, to carry specific amounts of additional dead load as considered appropriate for the structure.

C5.14.2.3.9

Integrated drawings utilizing the assumed system should be defined to a scale and quality required to confirm elimination of interferences by all items embedded in the concrete.

The concrete cross-section shall be proportioned to accommodate an assumed post-tensioning system, reinforcing steel, and all other embedded items. The concrete cross-section should also accommodate comparable anchorage sizes of competitive post-tensioning systems, unless noted otherwise on the plans.

Congested areas of post-tensioned concrete structures can easily be identified on integrated drawings using an assumed post-tensioning system. Such areas should include, but are not necessarily limited to, anchorage zones, areas containing embedded items for the assumed post-tensioning system, and areas where post-tensioning ducts deviate both in the vertical and transverse directions. For curved structures, conflicts between webs and external tendons are possible. A check should be made to identify conflicts between future post-tensioning tendons and permanent tendons, and to provide for the necessary clearances in the design details to accommodate the post-tensioning jacks.

5.14.2.3.10—Box Girder Cross-Section Dimensions and Details

5.14.2.3.10a—Minimum Flange Thickness

Top and bottom flange thickness shall not be less than any of the following:

- 1/30 the clear span between webs or haunches. A lesser dimension will require transverse ribs at a spacing equal to the clear span between webs or haunches.
- Top flange thickness shall not be less than 9.0 in. in anchorage zones where transverse post-tensioning is used and 8.0 in. beyond anchorage zones or for pretensioned slabs.

Transverse post-tensioning or pretensioning shall be used where the clear span between webs or haunches is 15.0 ft or larger. Strands used for transverse pretensioning shall be 0.5 in. diameter or less.

5.14.2.3.10b—Minimum Web Thickness

The following minimum values shall apply, except as specified herein:

- Webs with no longitudinal or vertical post-tensioning tendons—8.0 in.
- Webs with only longitudinal (or vertical) post-tensioning tendons—12.0 in.
- Webs with both longitudinal and vertical tendons—15.0 in.

The minimum thickness of ribbed webs may be taken as 7.0 in.

C5.14.2.3.10a

A top flange thickness of 9.0 in. is preferable in the area of anchorages for transverse post-tensioning tendons. A minimum flange thickness of 8.0 in. is recommended.

5.14.2.3.10c—Length of Top Flange Cantilever

The cantilever length of the top flange measured from the centerline of the web should preferably not exceed 0.45 the interior span of the top flange measured between the centerline of the webs.

5.14.2.3.10d—Overall Cross-Section Dimensions

Overall dimensions of the box girder cross-section should preferably not be less than that required to limit live load plus impact deflection calculated using the gross section moment of inertia and the secant modulus of elasticity to 1/1000 of the span. The live loading shall consist of all traffic lanes fully loaded and adjusted for the number of loaded lanes as specified in Article 3.6.1.1.2. The live loading shall be considered to be uniformly distributed to all longitudinal flexural members.

C5.14.2.3.10d

With four lanes of live load and using applicable reduction factors, the live load deflection of the model of the Corpus Christi Bridge was approximately $L/3200$ in the main span. The deflection limit of $L/1000$ was arbitrarily chosen to provide guidance concerning the maximum live load deflections anticipated for segmental concrete bridges with normal dimensions of the box girder cross-section.

Girder depth and web spacing determined in accordance with the following dimensional ranges will generally provide satisfactory deflection behavior:

- Constant depth girder

$$1/5 > d_o/L > 1/30$$

optimum 1/18 to 1/20

where:

d_o = girder depth (ft)

L = span length between supports (ft)

In case of incrementally launched girders, the girder depth should preferably be between the following limits:

$$\text{For } L = 100 \text{ ft, } 1/15 < d_o/L < 1/12$$

$$\text{For } L = 200 \text{ ft, } 1/13.5 < d_o/L < 1/11.5$$

$$\text{For } L = 300 \text{ ft, } 1/12 < d_o/L < 1/11$$

- Variable depth girder with straight haunches at pier $1/16 > d_o/L > 1/20$ optimum 1/18

at center of span $1/22 < d_o/L > 1/28$ optimum 1/24

A diaphragm will be required at the point where the bottom flange changes direction.

- Variable depth girder with circular or parabolic haunches at pier $1/16 > d_o/L > 1/20$

optimum 1/18

$$\text{at center of span } 1/30 > d_o/L > 1/50$$

Depth width ratio

A single cell box should preferably be used when $d_o/b \geq 1/6$

A two cell box should preferably be used when $d_o/b < 1/6$

where:

b = width of the top flange

If in a single cell box the limit of depth to width ratio given above is exceeded, a more rigorous analysis is required and longitudinal edge beams at the tip of the cantilever may be required to distribute loads acting on the cantilevers. An analysis for shear lag should be made in such cases. Transverse load distribution is not substantially increased by the use of three or more cells.

5.14.2.3.10e—Overlays

Overlays shall be considered for all bridge decks exposed to freeze thaw cycles and application of deicing chemicals. The governing authority should consider providing additional protection against penetration of chlorides. For all types of segmental bridges (precast and cast-in-place), it is recommended that this additional protection be provided by the addition of a minimum of 1.5 in. of concrete cover, added as an overlay or alternatively a waterproof membrane with bituminous overlay. The governing authority may require specific materials and placement techniques stipulated by local practices.

C5.14.2.3.10e

Overlays are encouraged instead of the inclusion of additional monolithic concrete because an overlay will add protection at the critical segment joint. Delamination of overlays is generally due to poor installation practices or material selection and can be resolved. It is not recommended that the additional cover be obtained by merely increasing concrete covers. The added cover will not add protection across the segment joint which is the area of most concern due to the ability of the water to migrate to the tendon and reinforcement.

Careful attention to detail is required when using overlays to assure the proper railing heights are obtained. All railings next to deck areas to be overlaid should be detailed from the top of the overlay.

The need to remove and replace the overlay can be based on measurement of chloride penetration into the overlay. Use of high performance concrete is an effective means of minimizing chloride penetration into concrete.

Bridges located in other corrosive environments, such as coastal bridges over salt water, should be evaluated for the need for additional protection.

5.14.2.3.11—Seismic Design

Segmental superstructure design with moment resisting column to superstructure connections shall consider the inelastic hinging forces from columns in accordance with Article 3.10.9.4.3. Bridge superstructures in Seismic Zones 3 and 4 with moment resisting column to superstructure connections shall be reinforced with ductile details to resist longitudinal and transverse flexural demands produced by column plastic hinging.

Segment joints shall provide capacity to transfer seismic demands.

C5.14.2.3.11

The distinction between bonded tendons and unbonded tendons with respect to seismic behavior reflects the general condition that bonded tendons are effectively bonded at all sections along the span, whereas unbonded tendons are effectively bonded at only their anchorages and intermediate bonded sections, such as deviators. Hence, the overall section strength achieved with bonded tendons is typically larger than that achieved with unbonded tendons. However, both bonded and unbonded tendons have been shown to provide significant displacement ductility.

Superstructure prestressing steel shall be designed to remain below yield for the combined dead load plus seismic demands. The stress in the prestressing steel may be computed by detailed moment curvature analysis, with the stress in bonded prestressing steel computed by strain compatibility with the section and the stress in unbonded prestressing steel computed using global displacement compatibility between bonded sections of tendons located within the span.

The California Department of Transportation evaluates capacity of concrete substructures using nonlinear "push-over" analysis. Various peer review teams urged this methodology following the Loma Prieta and Northridge earthquakes, in order to better access global behavior, and to achieve more economically-justifiable designs. Superstructures are designed for forces to resist plastic-hinging of the column(s). Frames are modeled using soil springs on the substructure, and stress-strain relationships for the concrete and steel. The frame is pushed, to incur plastic hinges in the columns, and reaches a point of collapse. The resulting displacement must be greater than that from a three-dimensional linear dynamic analysis. The acceleration response spectrum (ARS) may be generic for the soil-type and anticipated acceleration, or be developed for the specific bridge site.

5.14.2.4—Types of Segmental Bridges

5.14.2.4.1—General

Bridges designed for segmentally placed superstructures shall conform to the requirements specified herein, based on the concrete placement method and the erection methods to be used.

C5.14.2.4.1

Precast segmental bridges are normally erected by balanced cantilever, use of erection trusses, or progressive placement.

Bridges erected by balanced cantilever or progressive placement normally utilize internal tendons. Bridges built with erection trusses may utilize internal tendons, external tendons, or combinations thereof. Due to considerations of segment weight, span lengths for precast segmental box girder bridges, except for cable-stayed bridges, rarely exceed 400 ft.

5.14.2.4.2—Details for Precast Construction

The compressive strength of precast concrete segments shall not be less than 2.5 ksi prior to removal from the forms and shall have a maturity equivalent to 14 days at 70°F prior to assembly into the structure.

Multiple small-amplitude shear keys at match-cast joints in webs of precast segmental bridges shall extend over as much of the web as is compatible with other details. Details of shear keys in webs should be similar to those shown in Figure 5.14.2.4.2-1. Shear keys shall also be provided in top and bottom slabs. Keys in the top and bottom slabs may be larger single-element keys.

C5.14.2.4.2

This provision intends to limit the magnitude of construction deflections and to prevent erratic construction deflections and creep.

Small-amplitude shear keys in the webs are less susceptible to construction damage, which will result in loss of geometry control, than larger single-element keys. Shear keys in the top and bottom flanges are less susceptible to such damage.

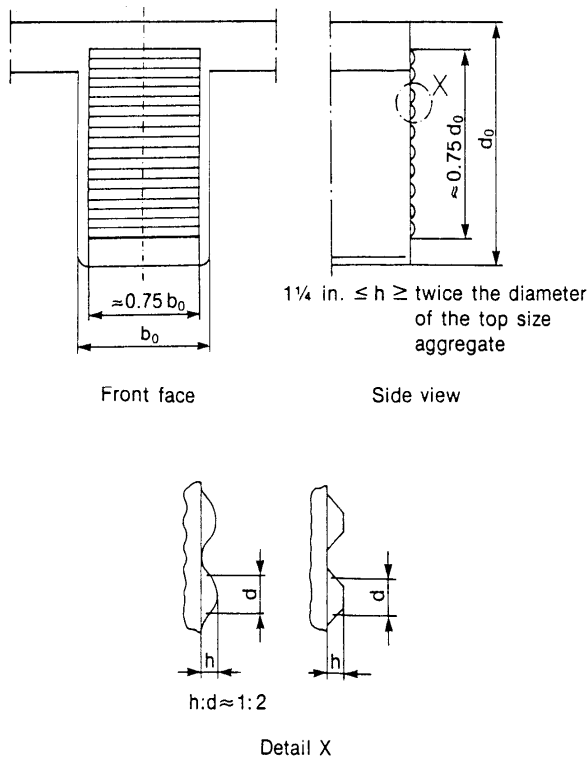

Figure 5.14.2.4.2-1—Example of Fine Indentation Shear Keys

Joints in precast segmental bridges shall be either cast-in-place closures or match cast epoxied joints.

Precast segmental bridges using internal post-tensioning tendons and bridges located in areas subject to freezing temperatures or deicing chemicals shall employ bonded joints.

Match casting is necessary to ensure control of the geometry upon reassembly of the segments.

Epoxy on both faces serves as a lubricant during placement of the segments, prevents water intrusion, provides a seal to prevent cross-over during grouting, and provides some tensile strength across the joint.

The use of dry joints (identified as Type B in past versions of these Specifications) was eliminated with the adoption of the 2003 revision due to the critical nature of post-tensioning reinforcing and the need for a multiple layer protection system. Failures of some post-tensioning reinforcing in Florida and Europe due to corrosion have resulted in a review of the effectiveness of previous multiple layer protection systems. The most rigorous review was performed by the British Concrete Society and the recommendations are contained in the report titled “Durable Post-Tensioned Concrete Bridges.” This European report codifies the need for a three-level protection system and suggested details to achieve the required results. Improved grout and duct materials and methods are also discussed. As a result of this European Report and studies by Dr. John Breen of the University of Texas, Austin, the multiple level protection system for post-tensioning has been universally accepted.

AASHTO LRFD Bridge Construction Specifications requires this temporary stress to ensure full bond and to prevent uneven epoxy thickness. Such variations could lead to a systematic accumulation of geometric error. Large stress changes on epoxy joints should be avoided during the initial curing period.

A temporary prestressing system shall provide a minimum compressive stress of 0.030 ksi and an average stress of 0.040 ksi across the joint until the epoxy has cured.

5.14.2.4.3—Details for Cast-in-Place Construction

Joints between cast-in-place segments shall be specified as either intentionally roughened to expose coarse aggregate or keyed.

The width of closure joints shall permit the coupling of the tendon ducts.

Diaphragms shall be provided at abutments, piers, hinge joints, and bottom flange angle points in structures with straight haunches. Diaphragms shall be substantially solid at piers and abutments, except for access openings and utility holes. Diaphragms shall be sufficiently wide as required by design, with a minimum overhang over bearings of not less than 6.0 in.

5.14.2.4.4—Cantilever Construction

The provisions specified herein shall apply to both precast and cast-in-place cantilever construction.

Longitudinal tendons may be anchored in the webs, in the slab, or in blisters built out from the web or slab. A minimum of two longitudinal tendons shall be anchored in each segment.

The cantilevered portion of the structure shall be investigated for overturning during erection. The factor of safety against overturning shall not be less than 1.5 under any combination of loads, as specified in Article 5.14.2.3.3. Minimum wind velocity for erection stability analyses shall be 55 mph, unless a better estimate of probable wind velocity is obtained by analysis or meteorological records.

Continuity tendons shall be anchored at least one segment beyond the point where they are theoretically required for stresses.

The segment lengths assumed in the design shall be shown on the plans. Any changes proposed by the Contractor shall be supported by reanalysis of the construction and computation of the final stresses.

The formtraveler weight assumed in stress and camber calculations shall be stated on the plans.

5.14.2.4.5—Span-by-Span Construction

Provisions shall be made in design of span-by-span construction for accumulated construction stresses due to the change in the structural system as construction progresses.

C5.14.2.4.3

AASHTO LRFD Bridge Construction Specifications requires vertical joints to be keyed. However, proper attention to roughened joint preparation is expected to ensure bond between the segments, providing better shear strength than shear keys.

C5.14.2.4.4

Stability during erection may be provided by moment resisting column/superstructure connections, falsework bents, or a launching girder. Loads to be considered include construction equipment, forms, stored material, and wind.

The 55 mph corresponds to the load factor 0.30 in Table 3.4.1-1.

Tendon force requires an “induction length” due to shear lag before it may be assumed to be effective over the whole section.

Lengths of segments for free cantilever construction usually range between 10.0 and 18.0 ft. Lengths may vary with the construction method, the span length and the location within the span.

Formtravelers for a typical 40.0-ft wide, two-lane bridge with 15.0- to 16.0-ft segments may be estimated to weigh 160 to 180 kips. Weight of formtravelers for wider two-cell box sections may range up to 280 kips. Segment length is adjusted for deeper and heavier segments to control segment weight. Consultation with contractors experienced in free cantilever construction is recommended to obtain a design value for formtraveler weight for a specific bridge cross-section.

C5.14.2.4.5

Span-by-span construction is defined as construction where the segments, either precast or cast-in-place, are assembled or cast on falsework supporting one entire span between permanent piers.

Stresses due to the changes in the structural system, in particular the effects of the application of a load to one system and its removal from a different system, shall be accounted for. Redistribution of such stresses by creep shall be taken into account and allowance made for possible variations in the creep rate and magnitude.

The falsework is removed after application of post-tensioning to make the span capable of supporting its own weight and any construction loads. Additional stressing may be utilized after adjacent spans are in place to develop continuity over piers.

5.14.2.4.6—*Incrementally Launched Construction*

5.14.2.4.6a—*General*

Stresses under all stages of launching shall not exceed the limits specified in Article 5.9.4 for members with bonded reinforcement through the joint and internal tendons.

Provision shall be made to resist the frictional forces on the substructure during launching and to restrain the superstructure if the structure is launched down a gradient. For determining the critical frictional forces, the friction on launching bearings shall be assumed to vary between zero and four percent, whichever is critical. The upper value may be reduced to 3.5 percent if pier deflections and launching jack forces are monitored during construction.

C5.14.2.4.6a

Incrementally launched girders are subject to reversal of moments during launching. Temporary piers and/or a launching nose may be used to reduce launching stresses.

These friction coefficients are only applicable to bearings employing a combination of virgin Teflon and stainless steel with a roughness of less than 1.0×10^{-4} in.

5.14.2.4.6b—*Force Effects Due to Construction Tolerances*

Force effects due to the following permissible construction tolerances shall be superimposed upon those resulting from gravity loads:

- In the longitudinal direction between two adjacent bearings 0.2 in.
- In the transverse direction between two adjacent bearings 0.1 in.
- Between the fabrication area and the launching equipment in the longitudinal and transverse direction 0.1 in.
- Lateral deviation at the outside of the webs 0.1 in.

The horizontal force acting on the lateral guides of the launching bearings shall not be taken to be less than one percent of the vertical support reaction.

For stresses during construction, one-half of the force effects due to construction tolerances and one-half of the force effects due to temperature in accordance with Article 5.14.2.3 shall be superimposed upon those from gravity loads. Concrete tensile stresses due to the combined moments shall not exceed $0.221\sqrt{f'_c}$.

5.14.2.4.6c—Design Details

Piers and superstructure diaphragms at piers shall be designed to permit jacking of the superstructure during all launching stages and for the installation of permanent bearings. Frictional forces during launching shall be considered.

Local stresses that may develop at the underside of the web during launching shall be investigated. The following requirements shall be satisfied:

- Launching pads shall be placed not closer than 3.0 in. to the outside of the web,
- Concrete cover between the soffit and post-tensioning ducts shall not be less than 6.0 in., and
- Bearing pressures at the web/soffit corner shall be investigated and the effects of ungrouted ducts and any eccentricity between the intersection of the centerlines of the web and the bottom slab and the centerline of the bearing shall be considered.

C5.14.2.4.6c

The dimensional restrictions on placement of launching bearings are shown in Figure C5.14.2.4.6c-1. Eccentricity between the intersection of the centerlines of the web and the bottom slab and the centerline of the bearing is illustrated in Figure C5.14.2.4.6c-2.

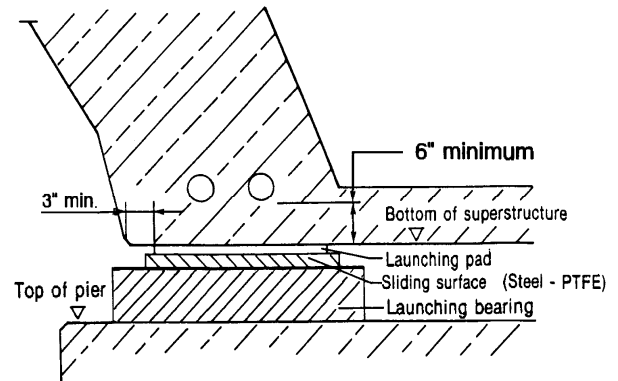

Figure C5.14.2.4.6c-1—Location of Launching Pads

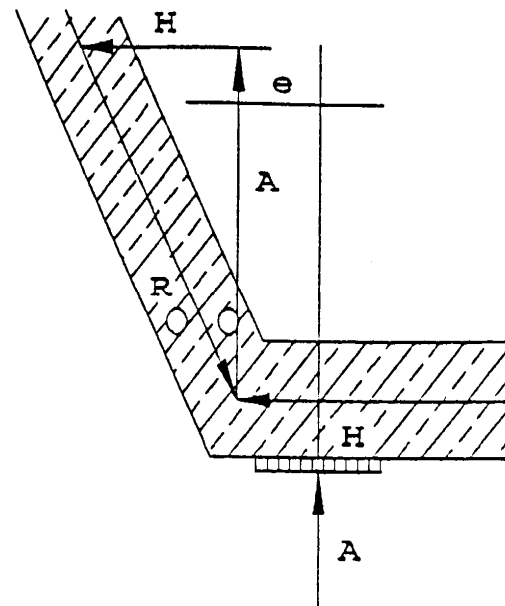

Figure C5.14.2.4.6c-2—Eccentric Reaction at Launching Pads

The straight tendons required for launching shall be placed in the top and bottom slabs for box girders and in the lower third of the web for T-sections. Not more than 50 percent of the tendons shall be coupled at one construction joint. Anchorages and locations for the straight tendons shall be designed for the concrete strength at the time of tensioning.

The faces of construction joints shall be provided with shear keys or a roughened surface with a minimum roughness amplitude of 0.25 in. Bonded nonprestressed

The stresses in each cross-section change from tension to compression during launching. These tensile stresses during launching are counteracted by the straight tendons. The straight tendons are stressed at an early concrete age (e.g., 3 days).

The inclined launching bearings, as opposed to horizontal permanent bearings, create forces at the launching jacks and at the pier tops.

reinforcement shall be provided longitudinally and transversely at all concrete surfaces crossing the joint and over a distance of 7.0 ft on either side of the joint. Minimum reinforcing shall be equivalent to No. 4 bars spaced at 5.0 in.

*5.14.2.4.6d—Design of Construction
Equipment*

Where construction equipment for incremental launching is shown on the contract documents, the design of such equipment shall include, but not be limited to the following features:

- The construction tolerances in the sliding surface at the bottom of the launching nose shall be limited to those of the superstructure, as specified in Article 5.14.2.4.6b.
- The introduction of the support reactions in the launching nose shall be investigated with respect to strength, stability, and deformation.
- Launching bearings shall be designed in such a way that they can compensate for local deviations of the sliding surface of up to 0.08 in. by elastic deformation.
- The launching equipment shall be sized for friction in accordance with Section 5.14.2.4.6a and the actual superstructure gradient.
- The launching equipment shall be designed to ensure that a power failure will not lead to uncontrolled sliding of the superstructure.
- The friction coefficient between concrete and the hardened profiled steel surfaces of the launching equipment shall be taken as 60 percent at the service limit state and the friction shall exceed the driving forces by 30 percent.

The forms for the sliding surfaces underneath and outside the web shall be wear-resistant and sufficiently stiff so that their deflection during casting does not exceed 0.08 in.

**5.14.2.5—Use of Alternative Construction
Methods**

When permitted by contract documents that do not require value engineering, the Contractor may be allowed to choose alternative construction methods and a modified post-tensioning layout suitable for the selected construction method. In such a case, the Contractor shall supply a structural analysis, documenting that the post-tensioning forces and eccentricities shown on the construction plans meet all requirements of the design specifications. If additional post-tensioning is required for construction stages or other reasons, it shall be demonstrated that the stresses

C5.14.2.5

Opinions vary among state bridge engineers and consultants about the desirability of permitting alternate construction methods. Some state transportation departments do not permit any deviation from the details and construction methods shown on the plans and specified in the contract special provisions. Other states permit great latitude for contractor submission of alternate construction methods. An example of the latter is presented below, which is taken verbatim from the contract documents for a recent California bridge project.

at critical sections in the final structure meet the allowable stress provisions of the design specifications. Removal of temporary post-tensioning to achieve such conditions shall be permissible. Use of additional nonprestressed reinforcement for construction stages shall be permitted. All extra materials required for construction stages shall be provided by the Contractor at no cost to the Owner.

Value engineering provisions may be included in the contract special provisions permitting alternative construction methods that require a complete redesign of the final structure. The Contractor's engineering expenses for preparing the value engineering design and the Owner's engineering expenses for checking the design shall be considered as part of the cost of the redesign structure.

Pier spacing, alignment, outside concrete, appearance, and dimensions shall not be changed under value engineering proposals, except when contract documents define such changes as being permitted.

For the value engineering, the Contractor shall provide a complete set of design computations and revised contract documents. The value engineering redesign shall be prepared by a Professional Engineer experienced in segmental bridge design. Upon acceptance of a value engineering redesign, the Professional Engineer responsible for the redesign shall become the Engineer of Record.

ALTERNATIVE PROPOSALS—Continuous cast-in-place prestressed box girder bridges have been designed to be fully supported during construction. Except as provided herein, such bridges shall be constructed on falsework and in accordance with the provisions in Section 51, "Concrete Structures," of the Standard Specifications.

The Contractor may submit proposals for such bridges which modify the original design assumptions for dead load support or the requirements in Section 51, 'Concrete Structures,' of the Standard Specifications. Such proposals are subject to the following requirements and limitation.

The structure shall, after completion, have a capacity to carry or resist loads at least equal to those used in the design of the bridge shown on the plans. When necessary, strengthening of the superstructure and the substructure will be required to provide such capacity and to support construction loads at each stage of construction.

All proposed modifications shall be designed in accordance with the bridge design specifications currently employed by the Department.

Modifications may be proposed in the thickness of girders and deck slabs, the thickness and length of overhang, the structure depth, the number of girders, and the amount and location of reinforcing steel or prestressing force. The strength of the concrete used may be increased, but the strength employed for design or analysis shall not exceed 6,000 psi.

Modifications may also be proposed in the requirements in 'Prestressing Concrete' of these special provisions which pertain to the minimum amount of prestressing force which must be provided by full length draped tendons.

No modifications will be permitted in the width of the bridge. Fixed connections at the tops and bottoms of columns shown on the plans shall not be eliminated.

Temporary prestressing tendons, if used, shall be detensioned and any temporary ducts shall be filled with grout before completion of the work. Temporary tendons shall be either removed or fully encased in grout before completion of the work.

The Contractor shall be responsible for determining construction camber and obtaining the final profile grade as shown on the plans. The Contractor shall provide the Engineer with diagrams showing the predicted deck profile at each construction stage for all portions of the completed bridge. Any remedial measures necessary to correct deviation from the predicted camber will be the responsibility of the Contractor.

The Contractor shall furnish to the Engineer complete working drawings and checked calculations for all changes proposed, including revisions in camber and falsework requirements, in accordance with the provisions of Section 5-1.02, 'Drawings,' of the Standard Specifications. The calculations must verify that all requirements are satisfied. Such drawings and

calculations shall be signed by an Engineer who is registered as a Civil Engineer in the State of California.

Working drawings and calculations shall be submitted sufficiently in advance of the start of the affected work to allow time for review by the Engineer and correction by the Contractor of the drawings without delaying the work. Such time shall be proportional to the complexity of the work, but in no case shall such time be less than eight weeks.

The Contractor shall reimburse the State for the cost of investigating the proposal. The Department may deduct such amount from any monies due, or that may become due, the Contractor under contract.

The Engineer shall be the sole judge as to the acceptability of any proposal and may disapprove any proposal which in his judgment may not produce a structure which is at least equivalent in all respects to the planned structure.

Any additional materials required or increased costs resulting from the use of such proposal will be considered to be for the convenience of the Contractor and no additional payment will be made therefore.”

5.14.2.6—Segmentally Constructed Bridge Substructures

5.14.2.6.1—General

Pier and abutment design shall conform to Section 11 and to the provisions of this section. Consideration shall be given to erection loads, moments, and shears imposed on piers and abutments by the construction method shown in the contract documents. Auxiliary supports and bracing shall be shown as required. Hollow, rectangular precast segmental piers shall be designed in accordance with Article 5.7.4.7. The area of discontinuous longitudinal nonprestressed reinforcement may be as specified in Article 5.14.2.6.3.

5.14.2.6.2—Construction Load Combinations

Tensile stresses in vertically prestressed substructures during construction shall be computed for applicable load combinations of Table 5.14.2.3.3-1.

5.14.2.6.3—Longitudinal Reinforcement of Hollow, Rectangular Precast Segmental Piers

The minimum area of discontinuous longitudinal nonprestressed reinforcement in hollow, rectangular precast segmental piers shall satisfy the shrinkage and temperature reinforcement provisions specified in Article 5.10.8.

C5.14.2.6.1

Nonsegmentally constructed substructures are addressed in Sections 10 and 11 and in Article 5.14.2.3.4b.

C5.14.2.6.3

Minimum longitudinal reinforcement of hollow, rectangular precast segmental piers is based on Article 5.10.8 for shrinkage and temperature reinforcement. This provision reflects the satisfactory performance of several segmental piers constructed between 1982 and 1995, with longitudinal reinforcement ratios ranging from 0.0014 to 0.0028. The discontinuous longitudinal bars in precast segmental piers do not carry significant loads. Tensile reinforcement of precast segmental piers is provided by post-tensioning tendons.

5.14.3—Arches

5.14.3.1—General

The shape of an arch shall be selected with the objective of minimizing flexure under the effect of combined permanent and transient loads.

5.14.3.2—Arch Ribs

The in-plane stability of the arch rib(s) shall be investigated using a modulus of elasticity and moment of inertia appropriate for the combination of loads and moment in the rib(s).

In lieu of a rigorous analysis, the effective length for buckling may be estimated as the product of the arch half span length and the factor specified in Table 4.5.3.2.2c-1.

For the analysis of arch ribs, the provisions of Article 4.5.3.2.2 may be applied. When using the approximate second-order correction for moment specified in Article 4.5.3.2.2c, an estimate of the short-term secant modulus of elasticity may be calculated, as specified in Article 5.4.2.4, based on a strength of $0.40f'_c$.

Arch ribs shall be reinforced as compression members. The minimum reinforcing of one percent of the gross concrete area shall be evenly distributed about the section of the rib. Confinement reinforcement shall be provided as required for columns.

Unfilled spandrel walls greater than 25.0 ft in height shall be braced by counterforts or diaphragms.

Spandrel walls shall be provided with expansion joints. Temperature reinforcing shall be provided corresponding to the joint spacing.

The spandrel wall shall be jointed at the springline.

The spandrel fill shall be provided with effective drainage. Filters shall be provided to prevent clogging of drains with fine material.

5.14.4—Slab Superstructures

5.14.4.1—Cast-in-Place Solid Slab Superstructures

Cast-in-place, longitudinally reinforced slabs may be either conventionally reinforced or prestressed and may be used as slab-type bridges.

The distribution of live load may be determined by a refined analysis or as specified in Article 4.6.2.3. Slabs

C5.14.3.2

Stability under long-term loads with a reduced modulus of elasticity may govern the stability. In this condition, there would typically be little flexural moment in the rib, the appropriate modulus of elasticity would be the long-term tangent modulus, and the appropriate moment of inertia would be the transformed section inertia. Under transient load conditions, the appropriate modulus of elasticity would be the short-term tangent modulus, and the appropriate moment of inertia would be the cracked section inertia, including the effects of the factored axial load.

The value indicated may be used in stability calculations because the scatter in predicted versus actual modulus of elasticity is greater than the difference between the tangent modulus and the secant modulus at stress ranges normally encountered.

The long-term modulus may be found by dividing the short-term modulus by the creep coefficient.

Under certain conditions the moment of inertia may be taken as the sum of the moment of inertia of the deck and the arch ribs at the quarter point. A large deflection analysis may be used to predict the in-plane buckling load. A preliminary estimate of second-order moments may be made by adding to the first-order moments the product of the thrust and the vertical deflection of the arch rib at the point under consideration.

The ACI 207.2R73 *Manual of Concrete Practice* contains a discussion of joint spacing and temperature reinforcement of restrained walls.

Drainage of the spandrel fill is important to ensure durability of the concrete in the rib and the spandrel walls and to control the unit weight of the spandrel fill. Drainage details should keep the drainage water from running down the ribs.

C5.14.4.1

In this simple bridge superstructure, the deck slab also serves as the principal load-carrying component. The concrete slab, which may be solid, voided, or ribbed, is supported directly on the substructures.

The provisions are based on the performance of the relatively small span structures constructed to date. Any

and slab bridges designed for moment in conformance with Article 4.6.2.3 may be considered satisfactory for shear.

Edge beams shall be provided as specified in Article 9.7.1.4.

Transverse distribution reinforcement shall be placed in the bottoms of all slabs, except culvert tops or bridge slabs, where the depth of fill over the slab exceeds 2.0 ft. The amount of the bottom transverse reinforcement may be determined by two-dimensional analysis, or the amount of distribution reinforcement may be taken as the percentage of the main reinforcement required for positive moment taken as:

- For longitudinal reinforced concrete construction:

$$\frac{100}{\sqrt{L}} \leq 50\% \quad (5.14.4.1-1)$$

- For longitudinal prestressed construction:

$$\frac{100}{\sqrt{L}} \frac{f_{pe}}{60} \leq 50\% \quad (5.14.4.1-2)$$

where:

L = span length (ft)

f_{pe} = effective stress in the prestressing steel after losses (ksi)

Transverse shrinkage and temperature reinforcement in the tops of slabs shall conform to the requirements of Article 5.10.8.

5.14.4.2—Cast-in-Place Voided Slab Superstructures

5.14.4.2.1—Cross-Section Dimensions

Cast-in-place voided slab superstructures may be post-tensioned both longitudinally and transversely.

For circular voids, the center-to-center spacing of the voids should not be less than the total depth of the slab, and the minimum thickness of concrete taken at the centerline of the void perpendicular to the outside surface shall not be less than 5.5 in.

For rectangular voids, the transverse width of the void should not exceed 1.5 times the depth of the void, the thickness of the web between voids should not be less than 20 percent of the total depth of the deck, and the minimum thickness of concrete above the voids shall not be less than 7.0 in.

significant deviation from successful past practice for larger units that may become both structurally and economically feasible under these Specifications should be reviewed carefully.

C5.14.4.2.1

Cross-sections of alternative typical round-voided concrete deck system, taken between piers, are shown in Figure C5.14.4.2.1-1, in which *PT* denotes post-tensioning.

The bottom flange depth shall satisfy the requirements specified in Article 5.14.1.5.1b.

Where the voids conform to the dimensional requirements herein and where the void ratio, based on cross-sectional area, does not exceed 40 percent, the superstructure may be analyzed as a slab, using either the provisions of Article 4.6.2.3 or a two-dimensional analysis for isotropic plates.

If the void ratio exceeds 40 percent, the superstructure shall be treated as cellular construction and analyzed as:

- A monolithic multicell box, as specified in Article 4.6.2.2.1, Type d,
- An orthotropic plate, or
- A three-dimensional continuum.

5.14.4.2.2—Minimum Number of Bearings

Columns may be framed into the superstructure, or a single bearing may be used for the internal supports of continuous structures. A minimum of two bearings shall be employed at end supports.

The transverse rotation of the superstructure shall not exceed 0.5 percent at service limit states.

5.14.4.2.3—Solid End Sections

A solid section at least 3.0 ft long but not less than five percent of the length of the span shall be provided at either end of a span. Post-tensioned anchorage zones shall satisfy the requirements specified in Article 5.10.9. In the absence of more refined analysis, the solid sections of the deck may be analyzed as a transverse beam distributing forces to bridge bearings and to post-tensioning anchorages.

5.14.4.2.4—General Design Requirements

For voided slabs conforming to the provisions of Article 5.14.4.2.1, global and local force effects due to wheel loads need not be combined. The top flange of deck with rectangular voids may be analyzed and designed as a framed slab or designed with the provisions of the empirical process, as specified in Article 9.7.2.

The top part of the slab over circular voids made with steel void-formers shall be post-tensioned transversely. At the minimum thickness of concrete, the average precompression after all losses, as specified in

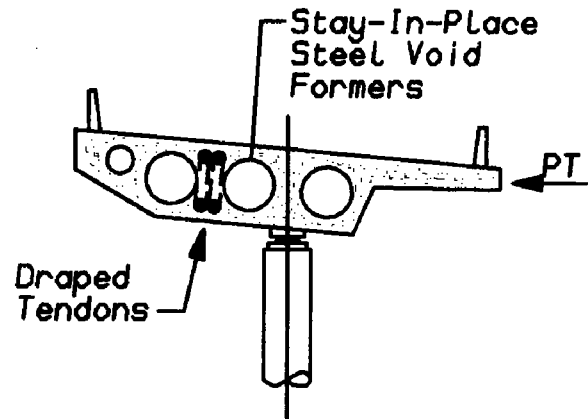

Figure C5.14.4.2.1-1—Cross-Section of Typical Voided Concrete Deck System

The dimensions provided for spacing and size of voids in this Article are based on past experience and are expected to provide safe results. They may be taken as preliminary design values.

C5.14.4.2.2

The high torsional stiffness of voided concrete decks and the inherent stability of horizontally curved continuous structures permits the use of a single support at internal piers. A minimum of two bearings are required at the abutments to ensure torsional stability in the end zones. If the torsional rotation requirement is not satisfied, pairs of bearings may be used at some internal piers.

C5.14.4.2.3

The intent is to provide for the distribution of concentrated post-tensioning and bearing forces to the voided sections. For relatively wide decks, the analysis of the solid sections as beams is an acceptable approximation. For deep and narrow decks, a three-dimensional analysis or use of a strut-and-tie model is advisable.

C5.14.4.2.4

Continuous voided decks should be longitudinally post-tensioned. Unless specified otherwise in this Article, or required for construction purposes, additional global longitudinal reinforcement may be deemed to be unnecessary if longitudinal post-tensioning is used. The preference for longitudinal post-tensioning of continuous decks reflects the limited experience with this system in North America.

Experience indicates that due to a combination of transverse bending moment, shrinkage of concrete around the steel void-former and Poisson's effect, where

Article 5.9.5, shall not be less than 0.5 ksi. When transversely post-tensioned, no additional reinforcing steel need be applied to the concrete above the circular voids.

Transverse shrinkage and temperature steel at the bottom of the voided slab shall satisfy the requirements specified in Article 5.10.8.

5.14.4.2.5—Compressive Zones in Negative Moment Area

At internal piers, the part of the cross-section under compressive stresses may be considered as a horizontal column and reinforced accordingly.

5.14.4.2.6—Drainage of Voids

Adequate drainage of the voids shall be provided in accordance with the provisions of Article 2.6.6.5.

5.14.4.3—Precast Deck Bridges

5.14.4.3.1—General

Precast concrete units placed adjacent to each other in the longitudinal direction may be joined together transversely to form a deck system. Precast concrete units may be continuous either for transient loads only or for both permanent and transient loads. Span-to-span continuity, where provided, shall be in accordance with the provisions of Article 5.14.1.3.2.

Where structural concrete overlay is not provided, the minimum thickness of concrete shall be 3.5 in. at the top of round voided components and 5.5 in. for all other components.

steel void-formers are used, high transverse tensile stresses tend to develop at the top of the deck, resulting in excessive cracking at the centerline of the void. The minimum transverse prestress specified to counteract this tension is a conservative value. The intent of transverse temperature steel at the bottom of voided deck is also for control of cracks resulting from transverse positive moments due to post-tensioning.

The hidden solid transverse beam over an internal pier may be post-tensioned.

C5.14.4.2.5

Recent tests on two-span, continuous, post-tensioned structures indicate that first failure occurs in the bottom compressive zones adjacent to the bearing at the internal pier. The failure is thought to be caused by a combination of shear and compression at those points in the bottom flange. The phenomenon is not yet clearly understood, and no specific design provisions have been developed. At this time, the best that can be done is to treat the bottom chord as a column with a reinforcement ratio of one percent and column-ties as specified in Article 5.10.6.

C5.14.4.2.6

Occasional cracks large enough to permit entry of water into the voids may develop in these deck systems. The accumulating water adds to gravitational loads and may cause structural damage when it freezes.

C5.14.4.3.1

Precast units may have solid, voided, box, T- and double-T cross-sections.

Differential creep and shrinkage due to differences in age, concrete mix, environmental, and support conditions have been observed to cause internal force effects that are difficult to predict at the design phase. These force effects are often relieved by separation of the joints, causing maintenance problems and negatively affecting structural performance.

Standard AASHTO-PCI prestressed concrete voided slab and box-beam sections, which are commonly used to construct precast deck bridges, have been used successfully for many years in bridges with and without a structural concrete overlay. The standard prestressed concrete overlay slab sections have 3.5 in., 4.0 in. and 4.5 in. of concrete over 8.0 in., 10.0 in. and 12.0 in. diameter voids respectively. All standard box beams including both 3.0 and 4.0 ft wide sections, are detailed with 5.5 in. of concrete over rectangular voids with corner fillets.

5.14.4.3.2—Shear Transfer Joints

Precast longitudinal components may be joined together transversely by a shear key not less than 7.0 in. in depth. For the purpose of analysis, the longitudinal shear transfer joints shall be modeled as hinges.

The joint shall be filled with nonshrinking grout with a minimum compressive strength of 5.0 ksi at 24 hours.

*5.14.4.3.3—Shear-Flexure Transfer Joints**5.14.4.3.3a—General*

Precast longitudinal components may be joined together by transverse post-tensioning, cast-in-place closure joints, a structural overlay, or a combination thereof.

5.14.4.3.3b—Design

Decks with shear-flexure transfer joints should be modeled as continuous plates, except that the empirical design procedure of Article 9.7.2 shall not be used. The joints shall be designed as flexural components, satisfying the provisions of Article 5.14.4.3.3d.

5.14.4.3.3c—Post-Tensioning

Transverse post-tensioning shall be uniformly distributed in the longitudinal direction. Block-outs may be used to facilitate splicing of the post-tensioning ducts. The compressed depth of the joint shall not be less than 7.0 in., and the prestress after all losses shall not be less than 0.25 ksi therein.

5.14.4.3.3d—Longitudinal Construction Joints

Longitudinal construction joints between precast concrete flexural components shall consist of a key filled with a nonshrinkage mortar attaining a compressive strength of 5.0 ksi within 24 hours. The depth of the key should not be less than 5.0 in.

If the components are post-tensioned together transversely, the top flanges may be assumed to act as a monolithic slab. However, the empirical slab design specified in Article 9.7.2 is not applicable.

The amount of transverse prestress may be determined by either the strip method or two-dimensional analysis. The transverse prestress, after all losses, shall not be less than 0.25 ksi through the key. In the last 3.0 ft at a free end, the required transverse prestress shall be doubled.

C5.14.4.3.2

Many bridges have indications of joint distress where load transfer among the components relies entirely on shear keys because the grout is subject to extensive cracking. Long-term performance of the key joint should be investigated for cracking and separation.

C5.14.4.3.3a

These joints are intended to provide full continuity and monolithic behavior of the deck.

C5.14.4.3.3b

From the modeling point of view, these precast concrete deck systems are not different from cast-in-place ones of the same geometry.

C5.14.4.3.3c

When tensioning narrow decks, losses due to anchorage setting should be kept to a minimum. Ducts should preferably be straight and grouted.

The post-tensioning force is known to spread at an angle of 45 degrees or larger and to attain a uniform distribution within a short distance from the cable anchorage. The economy of prestressing is also known to increase with the spacing of ducts. For these reasons, the spacing of the ducts need not be smaller than about 4.0 ft or the width of the component housing the anchorages, whichever is larger.

C5.14.4.3.3d

This Article relates to deck systems composed entirely of precast beams of box, T- and double-T sections, laid side-by-side and, preferably, joined together by transverse post-tensioning. The transverse post-tensioning tendons should be located at the centerline of the key.

Grinding of grout and concrete in the vicinity of the joint may be expected and specified for construction.

5.14.4.3.3e—Cast-in-Place Closure Joint

Concrete in the closure joint should have strength comparable to that of the precast components. The width of the longitudinal joint shall be large enough to accommodate development of reinforcement in the joint, but in no case shall the width of the joint be less than 12.0 in.

5.14.4.3.3f—Structural Overlay

Where a structural overlay is used to qualify for improved load distribution as provided in Articles 4.6.2.2.2 and 4.6.2.2.3, the thickness of structural concrete overlay shall not be less than 4.5 in. An isotropic layer of reinforcement shall be provided in accordance with the requirements of Article 5.10.8. The top surface of the precast components shall be roughened.

C5.14.4.3.3f

The composite overlay should be regarded as a structural component and should be designed and detailed accordingly.

5.14.5—Additional Provisions for Culverts

5.14.5.1—General

The soil structure aspects of culvert design are specified in Section 12.

5.14.5.2—Design for Flexure

The provisions of Article 5.7 shall apply.

5.14.5.3—Design for Shear in Slabs of Box Culverts

The provisions of Article 5.8 apply unless modified herein. For slabs of box culverts under 2.0 ft or more fill, shear strength V_c may be computed by:

$$V_c = \left(0.0676 \sqrt{f'_c} + 4.6 \frac{A_s V_u d_e}{b d_e M_u} \right) b d_e \quad (5.14.5.3-1)$$

but V_c shall not exceed $0.126 \sqrt{f'_c} b d_e$

where:

- A_s = area of reinforcing steel in the design width (in.²)
- d_e = effective depth from extreme compression fiber to the centroid of the tensile force in the tensile reinforcement (in.)
- V_u = shear from factored loads (kip)
- M_u = moment from factored loads (kip-in.)
- b = design width (in.)

For single-cell box culverts only, V_c for slabs monolithic with walls need not be taken to be less than $0.0948 \sqrt{f'_c} b d_e$, and V_c for slabs simply supported need

C5.14.5.3

Eq. 5.14.5.3-1, as originally proposed, included an additional multiplier to account for axial compression. Because the effect was considered relatively small, it was deleted from Eq. 5.14.5.3-1. However, if the Designer wishes, effect of axial compression may be included by multiplying the results of Eq. 5.14.5.3-1 by the quantity $(1+0.04 N_u/V_u)$.

The lower limits of $0.0948 \sqrt{f'_c}$ and $0.0791 \sqrt{f'_c}$ are compared with test results in Figure C5.14.5.3-1.

not be taken to be less than $0.0791\sqrt{f'_c}bd$. The quantity $V_u d_e / M_u$ shall not be taken to be greater than 1.0 where M_u is the factored moment occurring simultaneously with V_u at the section considered. The provisions of Articles 5.8 and 5.13.3.6 shall apply to slabs of box culverts under less than 2.0 ft of fill and to sidewalls.

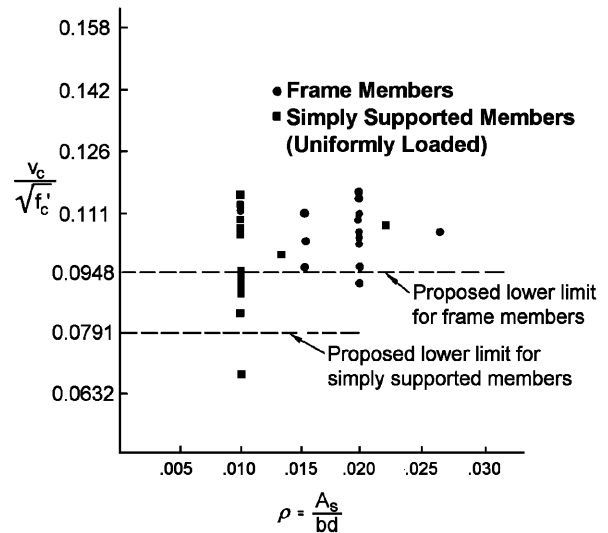

Figure C5.14.5.3-1—Culvert Test Results

5.15—REFERENCES

AASHTO. 1989. *Guide Specifications for Design and Construction of Segmental Concrete Bridges*, First Edition, GSCB-1. American Association of State Highway and Transportation Officials, Washington, DC.

AASHTO. 1999. *Guide Specification for Design and Construction of Segmental Concrete Bridges*, Second Edition, GSCB-2. American Association of State Highway and Transportation Officials, Washington, DC.

AASHTO LRFD Bridge Design Specifications, 4th Edition, American Association of State Highway and Transportation Officials, Washington, DC, 2007.

AASHTO. 2002. *Standard Specifications for Highway Bridges*, 17th Edition, HB-17. American Association of State Highway and Transportation Officials, Washington, DC.

AASHTO. 2011. *Standard Specifications for Transportation Materials and Methods of Sampling and Testing*, 31st Edition, HM-31. American Association of State Highway and Transportation Officials, Washington, DC.

Abdalla, O. A., J. A. Ramirez, and R. H. Lee. 1993. *Strand Debonding in Pretensioned Beams—Precast Prestressed Concrete Bridge Girders with Debonded Strands—Continuity Issues*, FHWA/INDOT/JHRP-92-94. Joint Highway Research Project, Indiana Department of Transportation/Purdue University, West Lafayette, IN, June 1993.

ACI. 1989. *Building Code Requirements for Reinforced Concrete and Commentary*. American Concrete Institute 318R-89. American Concrete Institute, Detroit, MI.

ACI. 1994. *Detailing Manual. Publication SP-66*. American Concrete Institute, Detroit, MI.

ACI. 1999. *Building Code Requirements for Structural Concrete. 318-99 and Commentary. 318R-99*. American Concrete Institute, Farmington Hills, MI.

ACI. 2002. *Building Code 318-02*. American Concrete Institute, Farmington Hills, MI.

ACI Committee 201. 1992. *Durability of Concrete*. ACI SP-131. American Concrete Institute, Farmington Hills, MI.

ACI Committee 207. 1973. *Manual of Concrete Practice*. ACI 207.2R73, American Concrete Institute, Farmington Hills, MI.

- ACI Committee 209. 1982. *Prediction of Creep, Shrinkage and Temperature Effects in Concrete Structures*. ACI 209R-82. American Concrete Institute, Farmington Hills, MI.
- ACI Committee 215. 1992. *Considerations for Design of Concrete Structures Subjected to Fatigue Loading*. ACI 215R-92. American Concrete Institute, Farmington Hills, MI. Reapproved in 1997.
- ACI Committee 222. 1987. *Corrosion of Metals in Concrete*. ACI 222R-85. American Concrete Institute, Detroit, MI.
- ACI Committee 318. *Building Code Requirements for Structural Concrete (ACI 318-08) and Commentary (ACI 318R-08)*, ACI, Farmington Hills, MI, 2008.
- ACI Committee 350. 1989. *Environmental Engineering Concrete Structures*. ACI 350R-89. American Concrete Institute, Farmington Hills, MI, p. 24.
- ACI Committee 363. 1992. *State-of-the-Art Report on High-Strength Concrete*. ACI 363R-92. American Concrete Institute, Farmington Hills, MI.
- ACI Committee 439. 1991. *Mechanical Connections of Reinforcing Bars*. ACI 439.3R. Vol. 88, No. 2, American Concrete Institute, Farmington Hills, MI, pp. 222–239.
- Al-Omaishi, N. 2001. *Prestress Losses in High Strength Pretensioned Concrete Bridge Girders*. Ph.D. dissertation, University of Nebraska-Lincoln, December 2001.
- Amorn, W., J. Bowers, A. Girgis, and M. K. Tadros. “Fatigue of Deformed Welded-Wire Reinforcement,” *PCI Journal*. Prestressed Concrete Institute, Chicago, IL, Vol. 52, No. 1, pp. 106–120.
- Anderson, A. R. 1973. “Stretched-Out AASHTO-PCI Beams Types III and IV for Longer Span Highway Bridges,” *PCI Journal*. Prestressed Concrete Institute, Chicago, IL, Vol. 18, No. 5, September–October 1973.
- ASCE. 1999. “A Direct Solution for Elastic Prestress Loss in Pretensioned Concrete Girders,” *Practice Periodical on Structural Design and Construction*. American Society of Civil Engineers, Reston, VA, November 1999.
- Bae, S., and O. Bayrak, 2003. “Stress Block Parameters for High Strength Concrete Members,” *ACI Structural Journal*. American Concrete Institute, Farmington Hills, MI, Vol. 100, No. 5, September–October 2003, pp. 626–636.
- Bakhoun, M. M., O. Buyukozturk, and S. M. Beattie. 1989. “Structural Performance of Joints on Precast Concrete Segmental Bridges.” *MIT Research Report No. R89-26*. Massachusetts Institute of Technology, Cambridge, MA, November 1989.
- Baran, E., A. E. Schultz, and C. E. French. 2005. “Analysis of the Flexural Strength of Prestressed Concrete Flanged Sections,” *PCI Journal*. Prestressed Concrete Institute, Chicago, IL, Vol. 50, No. 1, January–February 2005, pp. 74–93.
- Base, G. D., J. B. Reed, A. W. Beeby, and H. P. J. Taylor. 1966. *An Investigation of the Crack Control Characteristics of Various Types of Bar in Reinforced Concrete Beams*, Research Report No. 18. Cement and Concrete Association, London, England, December 1966, p. 44.
- Bayrak, O. 1999. “Seismic Performance of Rectilinearly Confined High-Strength Concrete Columns.” Ph.D. dissertation, University of Toronto, Ontario, Canada, pp. 80–187.
- Bazant, Z. P., and F. H. Wittman, eds. 1982. *Creep and Shrinkage in Concrete Structures*. John Wiley and Sons, Inc., New York, NY.
- Beaupre, R. J., L. C. Powell, J. E. Breen, and M. E. Kreger. 1988. “Deviation Saddle Behavior and Design for Externally Post-Tensioned Bridges,” *Research Report 365-2*. Center for Transportation Research, July 1988.
- Beeby, A. W. 1983. “Cracking, Cover and Corrosion of Reinforcement,” *Concrete International: Design and Construction*. American Concrete Institute, Farmington Hills, MI, Vol. 5, No. 2, February 1983, pp. 34–40.

- Bentz, E. C. and M. P. Collins. 2006. "Development of the 2004 CSA A23.3 Shear Provisions for Reinforced Concrete," *Canadian Journal of Civil Engineering*. NRC Research Press, Ottawa, ON, Canada, Vol. 33, No. 5, May 2006, pp. 521–534.
- Bentz, E. C., F. J. Vecchio, and M. P. Collins. 2006. "The Simplified MCFT for Calculating the Shear Strength of Reinforced Concrete Elements," *ACI Structural Journal*. American Concrete Institute, Farmington Hills, MI, Vol. 103, No. 4, July–August 2006, pp. 614–624.
- Breen, J. E., O. Burdet, C. Roberts, D. Sanders, and G. Wollmann. 1994. *Anchorage Zone Reinforcement for Post-Tensioned Concrete Girders*, NCHRP Report 356. Transportation Research Board, National Research Council, Washington, DC.
- Breen, J. E., and S. Kashima. 1991. "Verification of Load Distribution and Strength of Segmental Post-Tensioned Concrete Bridges," *Engineering Structures*. Vol. 13, No. 2.
- Bruce, R. N., H. G. Russell, and J. J. Roller. 2003. *Fatigue and Shear Behavior of HPC Bulb-Tee Girders*, FHWA/LA 03/382. Louisiana Transportation Research Center, Baton Rouge, LA. Interim report.
- Bryant, Anthony A., and Chavatit Vadhanavikkit. 1987. "Creep Shrinkage-Size, and Age at Loading Effects," *ACI Material Journal*. American Concrete Institute, Farmington Hills, MI, March–April 1987.
- Burdet, O. L. 1990. "Analysis and Design of Anchorage Zones in Post-Tensioned Concrete Bridges." Ph.D. diss. University of Texas, Austin, TX, May 1990.
- Castrodale, R. W., and C. D. White. 2004. "Extending Span Ranges of Precast, Prestressed Concrete Girders," *NCHRP Report 517*. Transportation Research Board, National Research Council, Washington, DC.
- CEB. 1990. *CEB-FIP Model Code for Concrete Structures*. Comite Euro-International de Beton. Available from Lewis Brooks, 2 Blagdon Road, New Malden, Surrey, KT3 4AD, England.
- Collins, M. P., and D. Mitchell. 1991. *Prestressed Concrete Structures*. Prentice Hall: Englewood Cliffs, NJ.
- Collins, M. P., D. Mitchell, P. E. Adebar, and F. J. Vecchio. 1996. "A General Shear Design Method," *ACI Structural Journal*. American Concrete Institute, Farmington Hills, MI, Vol. 93, No. 1, pp. 36–45.
- CRSI. *Manual of Standard Practice*. Concrete Reinforcing Steel Institute, Schaumburg, IL, 60195.
- CSA. 2004. *Design of Concrete Structures*, CSA A23.3-04. Canadian Standards Association, Mississauga, ON, Canada.
- DeCassio, R. D., and C. P. Siess. 1960. "Behavior and Strength in Shear of Beams and Frames without Web Reinforcement," *ACI Proceedings*. American Concrete Institute, Farmington Hills, MI, Vol. 56, February 1960.
- Destefano, R. J., J. Evans, M. K. Tadros, and C. Sun. 2003. "Flexural Crack Control in Concrete Bridge Structures." PCI Convention, October 19, 2003.
- FHWA. 1998. *A New Development Length Equation for Pretensioned Strands in Bridge Beams and Piles*, FHWA-RD-98-116. Federal Highway Administration, U.S. Department of Transportation, Washington, DC, December 1998.
- FHWA. 2006. *Seismic Retrofitting Manual for Highway Structures, Part 1—Bridges*, FHWA-HRT-06-032. Federal Highway Administration, U.S. Department of Transportation, Washington DC.
- Frantz G. C., and J. E. Breen. 1980. "Design Proposal for Side Face Crack Control Reinforcement for Large Reinforced Concrete Beams." *Concrete International: Design and Construction*, Vol. 2, No. 10, October 1980, pp. 29–34.
- Frosch, R. J. 2001. "Flexural Crack Control in Reinforced Concrete," *Design and Construction Practices to Mitigate Cracking*, SP-204. American Concrete Institute, Farmington Hills, MI, pp. 135–154.

- Fung, G., R. F. LeBeau, E. D., Klein, J. Belvedere, and A. G. Goldschmidt. 1971. *Field Investigation of Bridge Damage in the San Fernando Earthquake*. Bridge Department, Division of Highways, California Department of Transportation, Sacramento, CA.
- Gergely, P., and L. A. Lutz. 1968. "Maximum Crack Width in Reinforced Concrete Flexural Members." In *Causes, Mechanism, and Control of Cracking in Concrete*, SP-20. American Concrete Institute, Detroit, MI, pp. 87–117.
- Ghali, A., and R. Favre. 1968. *Concrete Structures, Stresses, and Deformations*. Chapman Hall: London, England, Appendix A.
- Girgis, A., C. Sun, and M. K. Tadros. 2002. "Flexural Strength of Continuous Bridge Girders—Avoiding the Penalty in the AASHTO LRFD Specifications," Open Forum: Problems and Solutions, *PCI Journal*. Prestressed Concrete Institute, Chicago, IL, Vol. 47, No. 4, July–August 2002, pp. 138–141.
- Griezic, A., W. D. Cook, and D. Mitchell. 1994. "Tests to Determine Performance of Deformed Welded Wire Fabric Stirrups," *ACI Structural Journal*. American Concrete Institute, Farmington Hills, MI, Vol. 91, No. 2, March–April 1994, pp. 211–220.
- Guyon, Y. 1953. *Prestressed Concrete*. John Wiley and Sons, Inc., New York, NY.
- Halvorsen, G. T. 1987. "Code Requirements for Crack Control." In *Proc. of the Lewis H. Tuthill International Symposium on Concrete and Concrete Construction*. SP104-15. 84-AB. American Concrete Institute, Farmington Hills, MI.
- Hamad, B. S., J. O. Jirsa, and N. I. D'Abreu. 1990. *Effect of Epoxy Coating on Bond and Anchorage of Reinforcement in Concrete Structures*, Research Project 1181-1F. Center for Transportation Research, University of Texas, Austin, TX, December 1990, p. 242.
- Hawkins, N. M., and D. A. Kuchma. 2006. *Simplified Shear Design of Structural Concrete Members*, NCHRP Report 549. Transportation Research Board, National Research Council, Washington, DC. Available online at http://onlinepubs.trb.org/onlinepubs/nchrp/nchrp_w78.pdf.
- Hawkins, N. M., and D. A. Kuchma. 2007. *Application of LRFD Bridge Design Specifications to High-Strength Structural Concrete: Shear Provisions*, NCHRP Report 579, Transportation Research Board, National Research Council, Washington, DC. Available online at http://onlinepubs.trb.org/onlinepubs/nchrp/nchrp_rpt_579.pdf.
- Hawkins, N. M., D. A. Kuchma, R. F. Mast, M. L. Marsh, and K. H. Reineck. 2005. *Simplified Shear Design of Structural Concrete Members*, NCHRP Report XX1. Transportation Research Board, National Research Council, Washington, DC.
- Hawkins, N. M., D. A. Kuchma, H. G. Russell, G. J. Klein, and N. S. Anderson. 2006. *Application of the LRFD Bridge Design Specifications to High-Strength Structural Concrete: Shear Provisions*, NCHRP Report XX2. Transportation Research Board, National Research Council, Washington, DC.
- Highway Engineering Division. 1991. *Ontario Highway Bridge Design Code*. Highway Engineering Division, Ministry of Transportation and Communications, Toronto, ON.
- Hofbeck, J. A., I. O. Ibrahim, and A. H. Mattock. 1969. "Shear Transfer in Reinforced Concrete," *ACI Journal*. American Concrete Institute, Farmington Hills, MI, Vol. 66, No. 2, February 1969, pp. 119–128.
- Hognestad, E. 1991. "Design Considerations for Service Life," *Concrete International: Design and Construction*. American Concrete Institute, Farmington Hills, MI, Vol. 13, No. 3, March 1991, pp. 57–60.
- Holombo, Jay et al. LRFD Minimum Flexural Reinforcement Requirements, NCHRP Web-Only Document 149. Transportation Research Board, 2009.
- Huo, X. S., N. Al-Omaishi, and M. K. Tadros. 2001. "Creep, Shrinkage, and Modulus of Elasticity of High Performance Concrete," *ACI Materials Journal*. American Concrete Institute, Farmington Hills, MI, Vol. 98, No. 6, November–December 2001, pp. 440–449.

- Ibrahim, H. H. H., and J. G. MacGregor. 1996. "Tests of Eccentrically Loaded High-Strength Concrete Columns," *ACI Structural Journal*. American Concrete Institute, Farmington Hills, MI, Vol. 93, No. 5, September–October 1996, pp. 585–594.
- Jirsa, J. O. 1979. "Applicability to Bridges of Experimental Seismic Test Results Performed on Subassemblages of Buildings." In *Proc. of a Workshop on the Earthquake Resistance of Highway Bridges*. Applied Technology Council, Berkeley, CA, January 1979.
- Jongpitaksseel, N., J. Bowers, W. Amornrattanepong, and M. K. Tadros. 2004. *Development of Fatigue Limit Formula for Deformed Welded Wire Reinforcement (WWR)*, 2004 Concrete Bridge Conference Paper #79. National Concrete Bridge Council, Charlotte, NC.
- Kaar, P. H. 1966. "High-Strength Bars as Concrete Reinforcement, Part 8: Similitude in Flexural Cracking of T-Beam Flanges," *Journal PCA Research and Development Laboratories*. Portland Cement Association, Skokie, IL, Vol. 8, No. 2, May 1966, pp. 2–12. Reprinted as *Development Department Bulletin D106*.
- Kaar, P. H., L. B. Kriz, and E. Hognestad. 1961. "Precast-Prestressed Concrete Bridges, 6. Test of Half-Scale Highway Bridge Continuous over Two Spans," *Journal of the PCA Research and Development Laboratories*. Vol. 3, No. 3, Sept. 1961, pp. 30–70. Also reprinted as *PCA Bulletin*, D51.
- Ketchum, M. A. 1986. *Redistribution of Stresses in Segmentally Erected Prestressed Concrete Bridges*, Report No. UCB/SESM-86/07. Department of Civil Engineering, University of California, Berkeley, CA, May 1986.
- Khan, A. A., W. D. Cook, and D. Mitchell. 1996. "Tensile Strength of Low, Medium, and High-Strength Concretes at Early Ages," *ACI Materials Journal*. American Concrete Institute, Farmington Hills, MI, Vol. 93, No. 5, September–October 1996, pp. 487–493.
- Kordina, K., and V. Weber. 1984. "Einfluss der Ausbildung unbewehrter Pressfugen auf die Tragfähigkeit von schräger Druckstreben in den Stegen von Segmentbauteilen." In *Deutscher Ausschuss für Stahlbeton*. Heft 350, Berlin, Germany.
- Koseki, K., and J. E. Breen. 1983. *Exploratory Study of Shear Strength of Joints for Precast Segmental Bridges*, Research Report 258-1. Center for Transportation Research, University of Texas, Austin, TX, September 1983.
- Lehman, D. et al. 2001. "Repair of Severely Damaged Bridge Columns," *ACI Structural Journal*. American Concrete Institute, Farmington Hills, MI, Vol. 98, No. 2, March 2001, pp. 233–242.
- Leonhardt, F. 1964. *Prestressed Concrete, Design, and Construction*. Wilhelm Ernest and Sohn: Berlin.
- Leonhardt, F. 1987. "Cracks and Crack Control in Concrete Structures." In *IABSE Proceedings*. P109/87, International Association for Bridge and Structural Engineers, Zurich, Switzerland, pp. 25–44.
- Loov, R. E. 1988. "A General Equation for the Steel Stress for Bonded Prestressed Tendons," *PCI Journal*. Prestressed Concrete Institute, Chicago, IL, Vol. 33, No. 6, November–December 1988, pp. 108–137.
- Loov, R. E., and A. K. Patnaik. 1994. "Horizontal Shear Strength of Composite Concrete Beams with a Rough Interface." *PCI Journal*, Vol. 39, No. 1, Prestressed Concrete Institute, Chicago, IL, January–February 1994, pp. 48–69. See also "Reader Comments," *PCI Journal*. Prestressed Concrete Institute, Chicago, IL, Vol. 39, No. 5, September–October 1994, pp. 106–109.
- Lwin, M., and B. Khaleghi. 1997. "Time-Dependent Prestress Losses in Prestressed Concrete Girders Built of High-Performance Concrete," *Transportation Research Record*. Transportation Research Board, National Research Council, Washington, DC, No. 1594.
- Ma, Z., X. Huo, M. K. Tadros, and M. Baishya. 1998. "Restraint Moments in Precast/Prestressed Concrete Continuous Bridges," *PCI Journal*. Prestressed Concrete Institute, Chicago, IL, Vol. 43, No. 6, November–December 1998, pp. 40–56.

- Ma, Z., M. K. Tadros, and M. Baishya. 2000. "Shear Behavior of Pretensioned High-Strength Concrete Bridge I-Girders," *ACI Structural Journal*. American Concrete Institute, Farmington Hills, MI, Vol. 97, No. 1, January–February 2000, pp. 185–192.
- MacGregor, R. J. G. 1989. "Evaluation of Strength and Ductility of the Three-Span Externally Post-Tensioned Box Girder Bridge Model." Ph.D. diss. University of Texas, Austin, TX, August 1989.
- MacGregor, R. J. G., M. E. Kreger, and J. E. Breen. 1989. *Strength and Ductility of a Three-Span Externally Post-Tensioned Bridge Model*, Research Report 365-3F. Center for Transportation Research, University of Texas, Austin, TX, January 1989.
- Mast, R. F. 1992. "Unified Design Provisions for Reinforced and Prestressed Concrete Flexural and Compression Members," *ACI Structural Journal*. American Concrete Institute, Farmington Hills, MI, Vol. 89, No. 2, March–April 1992, pp. 185–199. See also discussions by R. K. Devalapura and M. K. Tadros, C. W. Dolan and J. V. Loscheider and closure to discussions in Vol. 89, No. 5, September–October 1992, pp. 591–593.
- Mattock, A. H. 1961. "Precast-prestressed Concrete Bridges, 5. Creep and Shrinkage Studies," *Journal of the PCA Research and Development Laboratories*. Portland Cement Association, Skokie, IL, Vol. 3, No. 2, May 1961, pp. 32–66. Also reprinted as *PCA Bulletin*, D46.
- Mattock, A. H. 1974. "Shear Transfer in Concrete Having Reinforcement at an Angle to the Shear Plane." In Vol. 1, *Shear in Reinforced Concrete*. SP-42. American Concrete Institute, Farmington Hills, MI, pp.17–42.
- Mattock, A. H. 1987. "Anchorage of Stirrups in a Thin Cast-in-Place Topping," *PCI Journal*, Prestressed Concrete Institute, Chicago, IL, Vol. 32, No. 6, November–December 1987, pp. 70–85.
- Mattock, A. H., L. B. Kriz, and E. Hognestad. 1961. "Rectangular Concrete Stress Distribution in Ultimate Strength Design," *ACI Journal*. American Concrete Institute, Farmington Hills, MI, Vol. 32, No. 8, February 1961, pp. 875–928.
- MCEER/ATC. 2003. *Recommended LRFD Guidelines for the Seismic Design of Highway Bridges*, Special Publication No. MCEER-03-SP03. Multidisciplinary Center for Earthquake Engineering Research, Buffalo, NY.
- McLean, D. I., and C. L. Smith. 1997. *Noncontact Lap Splices in Bridge Column-Shaft Connections*, WA-RD 417.1. Washington State Transportation Center (TRAC), Pullman, WA and Washington State University, Olympia, WA.
- Menn, C. 1990. *Prestressed Concrete Bridges*. Birkhauser Verlag, Basel, Switzerland.
- Miller, R. A., R. Castrodale, A. Mirmiran, and M. Hastak. 2004. *Connection of Simple-Span Precast Concrete Girders for Continuity*, NCHRP Report 519. Transportation Research Board, National Research Council, Washington, DC.
- Mirmiran, A., S. Kulkarni, R. Castrodale, R. Miller, and M. Hastak. 2001. "Nonlinear Continuity Analysis of Precast, Prestressed Concrete Girders with Cast-in-Place Decks and Diaphragms," *PCI Journal*. Prestressed Concrete Institute, Chicago, IL, Vol. 46, No. 5, September–October 2001, pp. 60–80.
- Naaman, A. E. 1982. *Prestressed Concrete Analysis and Design: Fundamentals*. McGraw Hill, New York, NY, p. 670.
- Naaman, A. E. 1985. "Partially Prestressed Concrete: Review and Recommendations," *PCI Journal*. Prestressed Concrete Institute, Chicago, IL, Vol. 30, No. 6, November–December 1985, pp. 30–71.
- Naaman, A. E. 1987. "Proposed Revisions to ACI Building Code and Commentary. ACI 318-83." Proposal to ACI Committee 423, Prestressed Concrete Institute, Chicago, IL. First draft March 1987.
- Naaman, A. E. 1988. "Partially Prestressed Concrete: Design Methods and Proposed Code Recommendations." In *Proc., International Conference on Partially Prestressed Concrete Structures*. T. Javor, ed. Bratislava, Czechoslovakia, June 1988.
- Naaman, A. E. 1989. "Discussion of Loov 1988," *PCI Journal*. Prestressed Concrete Institute, Chicago, IL, Vol. 34, No. 6, November–December 1989, pp. 144–147.

- Naaman, A. E. 1990. "A New Methodology for the Analysis of Beams Prestressed with Unbonded Tendons." In *External Prestressing in Bridges*, ACI SP-120. A.E. Naaman and J. Breen, eds. American Concrete Institute, Farmington Hills, MI, pp. 339–354.
- Naaman, A. E. 1992. "Unified Design Recommendations for Reinforced Prestressed and Partially Prestressed Concrete Bending and Compression Members," *ACI Structural Journal*. American Concrete Institute, Farmington Hills, MI, Vol. 89, No. 2, March–April 1992, pp. 200–210.
- Naaman, A. E. 2002. "Rectangular Stress Block and T-Section Behavior," Open Forum: Problems and Solutions, *PCI Journal*. Prestressed Concrete Institute, Chicago, IL, Vol. 47, No. 5, September–October 2002, pp. 106–112.
- Naaman, A. E., et al. 1990. "Discussion of Skogman et al. 1988," *PCI Journal*. Prestressed Concrete Institute, Chicago, IL, Vol. 35, No. 2, March–April 1990, pp. 82–89.
- Naaman, A. E., and F. M. Alkhairi. 1991. "Stress at Ultimate in Unbonded Prestressing Tendons—Part I: Evaluation of the State-of-the-Art; Part II: Proposed Methodology," *ACI Structural Journal*. American Concrete Institute, Farmington Hills, MI, September–October 1991, November–December 1991; respectively.
- NCHRP. 2002. *Comprehensive Specification for the Seismic Design of Bridges*, NCHRP Report 472. Transportation Research Board, National Research Council, Washington DC.
- NCHRP. 2006. *Recommended LRFD Guidelines for the Seismic Design of Highway Bridges*, Draft Report NCHRP Project 20-07, Task 193. TRC Imbsen & Associates, Sacramento CA.
- Noppakunwijai, P., N. Jongpitakseel, Z. Ma, S. A. Yehia, and M. K. Tadros. 2002. "Pullout Capacity of Non-Prestressed Bent Strands for Prestressed Concrete Girders," *PCI Journal*. Prestressed Concrete Institute, Chicago, IL, Vol. 47, No. 4, July–August 2002, pp. 90–103.
- Nowak, A.S. and Rakoczy, A.M., "Statistical Parameters for Compressive Strength of Lightweight Concrete," Paper 68, Proceedings, Concrete Bridge Conference, Phoenix, AZ, February 24-25, 2010.
- Nowak, A.S.; Szerszen, M. M.; Szeliga, E.K.; Szwed, A., and Podhorecki, P.J., *Reliability-Based Calibration for Structural Concrete, Phase 3*, SN2849, Portland Cement Association, Skokie, Illinois, USA, 2008, 115 pages.
- Nutt, R. 2008. Design Specifications and Commentary for Horizontally Curved Concrete Box-Girder Highway Bridges, NCHRP Report 620. Transportation Research Board, Washington, DC.
- O'Connor, C. 1971. *Design of Bridge Superstructures*. Wiley-Interscience, New York, NY, p. 533.
- Ozden, S., 1992. "Behavior of High-Strength Concrete under Strain Gradient." M.A. thesis, University of Toronto, Ontario, Canada, pp. 112–113.
- Paczkowski, P. and Nowak, A. S., "Reliability Models for Shear in Lightweight Reinforced Concrete Bridges," Paper 69, Proceedings, Concrete Bridge Conference, Phoenix, AZ, February 24-25, 2010.
- Pauley, T., and M. J. N. Priestley. 1992. *Seismic Design of Reinforced Concrete and Masonry Buildings*. John Wiley and Sons, Inc., New York, NY.
- PCA. 2002. *PCA Notes on ACI 318-02 Building Code Requirements for Structural Concrete with Design Applications*. Portland Cement Association, Skokie, IL.
- PCI. 1975. "Recommendations for Estimating Prestress Losses," *PCI Journal*. Prestressed Concrete Institute, Chicago, IL, Vol. 20, No. 4, July–August 1975.
- PCI. 1978. "Precast Segmental Box Girder Bridge Manual." Post-Tensioning Institute, Phoenix, Arizona, and Prestressed Concrete Institute, Chicago, IL.
- PCI. 1992. *PCI Design Handbook*, Fourth Edition. The Precast/Prestressed Concrete Institute, Chicago, IL.

- Podolny, Jr., Walter. 1986. "Evaluation of Transverse Flange Forces Induced by Laterally Inclined Longitudinal Post-Tensioning in Box Girder Bridges," *PCI Journal*. Prestressed Concrete Institute, Chicago, IL, Vol. 31, No. 1, January–February 1986.
- Podolny, J. W. and J. M. Muller. 1982. *Construction and Design of Prestressed Concrete Segmental Bridges*. Wiley, New York, NY.
- Posten, R. W., R. L. Carrasquillo, and J. E. Breen. 1987. "Durability of Post-Tensioned Bridge Decks," *ACI Materials Journal*. American Concrete Institute, Farmington Hills, MI, July–August 1987.
- Priestley, M. J. N. 1993. *Assessment and Design of Joints for Single-Level Bridges with Circular Columns*. Department of Applied Mechanics and Engineering Sciences, University of California, San Diego, CA, February 1993.
- Priestley, M. J. N., and R. Park. 1979. "Seismic Resistance of Reinforced Concrete Bridge Columns." In *Proc. of a Workshop on the Earthquake Resistance of Highway Bridges*. Applied Technology Council, Berkeley, CA, January 1979.
- Priestley, M. J. N., R. Park, and R. T. Potangaroa. 1981. "Ductility of Spirally Confined Concrete Columns," *Transactions of the ASCE Structural Division*. American Society of Civil Engineers, Washington, DC, Vol. 107, No. ST4, January 1981, pp. 181–202.
- Priestley, M. J. N., and J. R. Tao. 1993. "Seismic Response of Precast Prestressed Concrete Frames with Partially Debonded Tendons," *PCI Journal*. Prestressed Concrete Institute, Chicago, IL, Vol. 38, No. 1, January–February 1993, pp. 58–69.
- Rabbat, B. G., and M. P. Collins. 1976. "The Computer-Aided Design of Structural Concrete Sections Subjected to Combined Loading." Presented at the Second National Symposium on Computerized Structural Analysis and Design, Washington, DC, March 1976.
- Rabbat, B. G., and M. P. Collins. 1978. "A Variable Angle Space Truss Model for Structural Concrete Members Subjected to Complex Loading." In *Douglas McHenry International Symposium on Concrete and Concrete Structures*, SP55. American Concrete Institute, Farmington Hills, MI, pp. 547–587.
- Ramirez, G. 1989. "Behavior of Unbonded Post-Tensioning Segmental Beams with Multiple Shear Keys." Masters thesis. University of Texas, Austin, TX, January 1989.
- Roberts, C. L. 1990. "Behavior and Design of the Local Anchorage Zone in Post-Tensioned Concrete." Masters thesis. University of Texas, Austin, TX, May 1990.
- Roberts, C. L. 1993. "Measurement-Based Revisions for Segmental Bridge Design and Construction Criteria." Ph.D. diss. University of Texas, Austin, TX, December 1993.
- Rusch, H., D. Jungwirth, and H. K. Hilsdort. 1983. *Creep and Shrinkage*. Springer Verlag, New York, NY.
- Russell, B. W., and N. H. Burns. 1993. *Design Guidelines for Transfer, Development and Debonding for Large Diameter Seven Wire Strands in Pretensioned Concrete Girders*. The Texas Center for Transportation Research, Report 1210-5F, Texas Department of Transportation; Federal Highway Administration, Report FHWA/TX-93+1210-5F.
- Russell, H., C. Ozyildirim, M. K. Tadros, and R. Miller. 2003. *Compilation and Evaluation of Results from High Performance Concrete Bridge Projects*. Project DTFH61-00-C-00009 Compact Disc, Federal Highway Administration, U.S. Department of Transportation, Washington, DC.
- Salmons, J. R. 1980. *Behavior of Untensioned-Bonded Prestressing Strand*. Final Report 77-1, Missouri Cooperative Highway Research Program, Missouri State Highway Department, Jefferson City, MO, June 1980.

- Sanders, D. H. 1990. "Design and Behavior of Post-Tensioned Concrete Anchorage Zones." Ph.D. diss. University of Texas, Austin, TX, August 1990.
- Schlaich, J., K. Schäfer, M. Jennewein. 1987. "Towards a Consistent Design of Structural Concrete," *PCI Journal*. Prestressed Concrete Institute, Chicago, IL, Vol. 32, No. 3, May–June 1987, pp. 74–151.
- Schlaich, J., and H. Scheef. 1982. *Concrete Box Girder Bridges*. International Association for Bridge and Structural Engineering, Zurich, Switzerland.
- Seguirant, S. J. 2002. "Effective Compression Depth of T-Sections at Nominal Flexural Strength." Open Forum: Problems and Solutions, *PCI Journal*. Prestressed Concrete Institute, Chicago, IL, Vol. 47, No. 1, January–February 2002, pp. 100–105. See also discussion by A. E. Naaman and closure to discussion in Vol. 47, No. 3, May–June 2002, pp. 107–113.
- Seguirant, S. J., R. Brice, and B. Khaleghi. 2005. "Flexural Strength of Reinforced and Prestressed Concrete T-Beams," *PCI Journal*. Prestressed Concrete Institute, Chicago, IL, Vol. 50, No. 1, January–February 2005, pp. 44–73.
- Shahawy, M., and de V Batchelor, B. 1991. *Bond and Shear Behavior of Prestressed AASHTO Type II Beams*, Progress Report. Structural Research Center, Florida Department of Transportation, February 1991.
- Shahawy, M., B. Robinson, and de V Batchelor, B. 1993. *An Investigation of Shear Strength of Prestressed Concrete AASHTO Type II Girders*, Research Report. Structures Research Center, Florida Department of Transportation, January 1993.
- Shioya, T., M. Iguro, Y. Nojiri, H. Akiyama, and T. Okada. 1989. "Shear Strength of Large Reinforced Concrete Beams." In *Fracture Mechanics: Applications to Concrete*, SP-118. American Concrete Institute, Detroit, MI.
- Skogman, B. C., M. K. Tadros, and R. Grasmick. 1988. "Ductility of Reinforced and Prestressed Concrete Flexural Members," *PCI Journal*. Prestressed Concrete Institute, Chicago, IL, Vol. 33, No. 6, November–December 1988, pp. 94–107.
- Stone, W. C., and J. E. Breen. 1984. "Behavior of Post-Tensioned Girder Anchorage Zones," *PCI Journal*. Prestressed Concrete Institute, Chicago, IL, Vol. 29, No. 1, January–February 1984, pp. 64–109.
- Stone, W. C., and J. E. Breen. 1984. "Design of Post-Tensioned Girder Anchorage Zones," *PCI Journal*. Prestressed Concrete Institute, Chicago, IL, Vol. 29, No. 2, March–April 1984, pp. 28–61.
- Tadros, M. K., N. Al-Omaishi, S. P. Seguirant, and J. G. Gallt. 2003. *Prestress Losses in Pretensioned High-Strength Concrete Bridge Girders*, NCHRP Report 496. Transportation Research Board, National Research Council, Washington, DC.
- Tassin, D., B. Dodson, T. Takobayashi, K. Deaprasertwong, and Y. W. Leung. 1995. *Computer Analysis and Full-Scale Test of the Ultimate Capacity of a Precast Segmental Box Girder Bridge with Dry Joints and External Tendons*. American Segmental Bridge Institute, Phoenix, AZ.
- Taylor, A. W., R. B. Rowell, and J. E. Breen. 1990. *Design Behavior of Thin Walls in Hollow Concrete Bridge Piers and Pylons*, Research Report 1180-1F. Center for Transportation Research, University of Texas, Austin, TX.
- U.S. Government Printing Office. 1981. *Concrete Manual*, Eighth Edition. Bureau of Reclamation, U.S. Government Printing Office, Washington, DC, p. 627.
- Van Landuyt, D. W. 1991. "The Effect of Duct Arrangement on Breakout of Internal Post-Tensioning Tendons in Horizontally Curved Concrete Box-girder Webs," Thesis. University of Texas at Austin.
- Vecchio, F. J., and M. P. Collins. 1986. "The Modified Compression Field Theory for Reinforced Concrete Elements Subjected to Shear," *Journal of the American Concrete Institute*. American Concrete Institute, Farmington Hills, MI, Vol. 83, No. 2, pp. 219–231.

Walker, S., and D. L. Bloem. 1960. "Effect of Aggregate Size on Properties of Concrete," *Journal of the American Concrete Institute*. American Concrete Institute, Farmington Hills, MI, Vol. 57, No. 3, September 1960, pp. 283–298.

Walraven, J., J. Fronay, and A. Pruijssers. 1987. "Influence of Concrete Strength and Load History on the Shear Friction Capacity of Concrete Members," *PCI Journal*. Prestressed Concrete Institute, Chicago, IL, Vol. 32, No. 1, January–February 1987, pp. 66–84. See also "Reader Comments," *PCI Journal*. Prestressed Concrete Institute, Chicago, IL, Vol. 33, No. 1, January–February 1988, pp. 166–168.

Weigel, J. A., S. J. Seguirant, R. Brice, and B. Khaleghi, B. 2003. "High Performance Precast, Prestressed Concrete Girder Bridges in Washington State," *PCI Journal*. Prestressed Concrete Institute, Chicago, IL, Vol. 48, No. 2, March–April 2003, pp. 28–52.

Weigel, J. A., Seguirant, S. J., Brice, R., and Khaleghi, B. 2003. "High Performance Precast, Prestressed Concrete Girder Bridges in Washington State," *PCI Journal*. Prestressed Concrete Institute, Chicago, IL, Vol. 48, No. 2, March–April 2003, pp. 28–52.

Wollmann, G. P. 1992. *Anchorage Zones in Post-Tensioned Concrete*. University of Texas, Austin, TX, May 1992.

Zia, P., H. K. Preston, N. L. Scott, and E. B. Workman. 1979. "Estimating Prestress Losses," *Concrete International: Design and Construction*. American Concrete Institute, Farmington Hills, MI, Vol. 1, June 1979, pp. 32–38.

APPENDIX A5—BASIC STEPS FOR CONCRETE BRIDGES**A5.1—GENERAL**

This outline is intended to be a generic overview of the design process using the simplified methods for illustration. It should not be regarded as complete, nor should it be used as a substitute for a working knowledge of the provisions of this section.

A5.2—GENERAL CONSIDERATIONS

- A. Design Philosophy (1.3.1)
- B. Limit States (1.3.2)
- C. Design Objectives and Location Features (2.3) (2.5)

A5.3—BEAM AND GIRDER SUPERSTRUCTURE DESIGN

- A. Develop General Section
 - 1. Roadway Width (Highway-Specified)
 - 2. Span Arrangements (2.3.2) (2.5.4) (2.5.5) (2.6)
 - 3. Select Bridge Type
- B. Develop Typical Section
 - 1. Precast P/S Beams
 - a. Top Flange (5.14.1.2.2)
 - b. Bottom Flange (5.14.1.2.2)
 - c. Webs (5.14.1.2.2)
 - d. Structure Depth (2.5.2.6.3)
 - e. Minimum Reinforcement (5.7.3.3.2) (5.7.3.4)
 - f. Lifting Devices (5.14.1.2.3)
 - g. Joints (5.14.1.3.2)
 - 2. CIP T-Beams and Multiweb Box Girders (5.14.1.5)
 - a. Top Flange (5.14.1.5.1a)
 - b. Bottom Flange (5.14.1.5.1b)
 - c. Webs (5.14.1.5.1c)
 - d. Structure Depth (2.5.2.6.3)
 - e. Reinforcement (5.14.1.5.2)
 - (1) Minimum Reinforcement (5.7.3.3.2) (5.7.3.4)
 - (2) Temperature and Shrinkage Reinforcement (5.10.8)
 - f. Effective Flange Widths (4.6.2.6)
 - g. Strut-and-Tie Areas, if Any (5.6.3)
- C. Design Conventionally Reinforced Concrete Deck
 - 1. Deck Slabs (4.6.2.1)
 - 2. Minimum Depth (9.7.1.1)
 - 3. Empirical Design (9.7.2)
 - 4. Traditional Design (9.7.3)
 - 5. Strip Method (4.6.2.1)
 - 6. Live Load Application (3.6.1.3.3) (4.6.2.1.5)
 - 7. Distribution Reinforcement (9.7.3.2)
 - 8. Overhang Design (A13.4) (3.6.1.3.4)
- D. Select Resistance Factors
 - Strength Limit State (Conventional) (5.5.4.2.1)
- E. Select Load Modifiers
 - 1. Ductility (1.3.3)
 - 2. Redundancy (1.3.4)
 - 3. Operational Importance (1.3.5)
- F. Select Applicable Load Combinations and Load Factors (3.4.1, Table 3.4.1-1)
- G. Calculate Live Load Force Effects
 - 1. Live Loads (3.6.1) and Number of Lanes (3.6.1.1.1)
 - 2. Multiple Presence (3.6.1.1.2)
 - 3. Dynamic Load Allowance (3.6.2)
 - 4. Distribution Factor for Moment (4.6.2.2.2)

- a. Interior Beams with Concrete Decks (4.6.2.2.2b)
 - b. Exterior Beams (4.6.2.2.2d)
 - c. Skewed Bridges (4.6.2.2.2e)
- 5. Distribution Factor for Shear (4.6.2.2.3)
 - a. Interior Beams (4.6.2.2.3a)
 - b. Exterior Beams (4.6.2.2.3b)
 - c. Skewed Bridges (4.6.2.2.3c, Table 4.6.2.2.3c-1)
- 6. Reactions to Substructure (3.6)
- H. Calculate Force Effects from Other Loads as Required
- I. Investigate Service Limit State
 - 1. P/S Losses (5.9.5)
 - 2. Stress Limitations for P/S Tendons (5.9.3)
 - 3. Stress Limitations for P/S Concrete (5.9.4)
 - a. Before Losses (5.9.4.1)
 - b. After Losses (5.9.4.2)
 - 4. Durability (5.12)
 - 5. Crack Control (5.7.3.4)
 - 6. Fatigue, if Applicable (5.5.3)
 - 7. Deflection and Camber (2.5.2.6.2) (3.6.1.3.2) (5.7.3.6.2)
- J. Investigate Strength Limit State
 - 1. Flexure
 - a. Stress in P/S Steel—Bonded Tendons (5.7.3.1.1)
 - b. Stress in P/S Steel—Unbonded Tendons (5.7.3.1.2)
 - c. Flexural Resistance (5.7.3.2)
 - d. Limits for Reinforcement (5.7.3.3)
 - 2. Shear (Assuming No Torsional Moment)
 - a. General Requirements (5.8.2)
 - b. Sectional Design Model (5.8.3)
 - (1) Nominal Shear Resistance (5.8.3.3)
 - (2) Determination of β and θ (5.8.3.4)
 - (3) Longitudinal Reinforcement (5.8.3.5)
 - (4) Transverse Reinforcement (5.8.2.4) (5.8.2.5) (5.8.2.6) (5.8.2.7)
 - (5) Horizontal Shear (5.8.4)
- K. Check Details
 - 1. Cover Requirements (5.12.3)
 - 2. Development Length—Reinforcing Steel (5.11.1) (5.11.2)
 - 3. Development Length—Prestressing Steel (5.11.4)
 - 4. Splices (5.11.5) (5.11.6)
 - 5. Anchorage Zones
 - a. Post-Tensioned (5.10.9)
 - b. Pretensioned (5.10.10)
 - 6. Ducts (5.4.6)
 - 7. Tendon Profile Limitation
 - a. Tendon Confinement (5.10.4)
 - b. Curved Tendons (5.10.4)
 - c. Spacing Limits (5.10.3.3)
 - 8. Reinforcement Spacing Limits (5.10.3)
 - 9. Transverse Reinforcement (5.8.2.6) (5.8.2.7) (5.8.2.8)
 - 10. Beam Ledges (5.13.2.5)

A5.4—SLAB BRIDGES

Generally, the design approach for slab bridges is similar to beam and girder bridges with some exceptions, as noted below.

- A. Check Minimum Recommended Depth (2.5.2.6.3)
- B. Determine Live Load Strip Width (4.6.2.3)
- C. Determine Applicability of Live Load for Decks and Deck Systems (3.6.1.3.3)
- D. Design Edge Beam (9.7.1.4)
- E. Investigate Shear (5.14.4.1)
- F. Investigate Distribution Reinforcement (5.14.4.1)

- G. If Not Solid
 - 1. Check if Voided Slab or Cellular Construction (5.14.4.2.1)
 - 2. Check Minimum and Maximum Dimensions (5.14.4.2.1)
 - 3. Design Diaphragms (5.14.4.2.3)
 - 4. Check Design Requirements (5.14.4.2.4)

A5.5—SUBSTRUCTURE DESIGN

- A. Establish Minimum Seat Width
- B. Compile Force Effects Not Compiled for Superstructure
 - 1. Wind (3.8)
 - 2. Water (3.7)
 - 3. Effect of Scour (2.6.4.4.2)
 - 4. Ice (3.9)
 - 5. Earthquake (3.10) (4.7.4)
 - 6. Temperature (3.12.2) (3.12.3) (4.6.6)
 - 7. Superimposed Deformation (3.12)
 - 8. Ship Collision (3.14) (4.7.5)
 - 9. Vehicular Collision (3.6.5)
 - 10. Braking Force (3.6.4)
 - 11. Centrifugal Force (3.6.3)
 - 12. Earth Pressure (3.11)
- C. Analyze Structure and Compile Load Combinations
 - 1. Table 3.4.1-1
 - 2. Special Earthquake Load Combinations (3.10.8)
- D. Design Compression Members (5.7.4)
 - 1. Factored Axial Resistance (5.7.4.4)
 - 2. Biaxial Flexure (5.7.4.5)
 - 3. Slenderness Effects (4.5.3.2.2) (5.7.4.3)
 - 4. Transverse Reinforcement (5.7.4.6)
 - 5. Shear (Usually EQ and Ship Collision Induced) (3.10.9.4.3)
 - 6. Reinforcement Limits (5.7.4.2)
 - 7. Bearing (5.7.5)
 - 8. Durability (5.12)
 - 9. Detailing (As in Step A5.3K) and Seismic (5.10.11)
- E. Design Foundations (Structural Considerations)
 - 1. Scour
 - 2. Footings (5.13.3)
 - 3. Abutments (Section 11)
 - 4. Pile Detailing (5.13.4)

APPENDIX B5—GENERAL PROCEDURE FOR SHEAR DESIGN WITH TABLES

B5.1—BACKGROUND

The general procedure herein is an acceptable alternative to the procedure specified in Article 5.8.3.4.2. The procedure in this Appendix utilizes tabularized values of β and θ instead of Eqs. 5.8.3.4.2-1, 5.8.3.4.2-2, and 5.8.3.4.2-3. Appendix B5 is a complete presentation of the general procedures in LRFD Design (2007) without any interim changes.

B5.2—SECTIONAL DESIGN MODEL— GENERAL PROCEDURE

For sections containing at least the minimum amount of transverse reinforcement specified in Article 5.8.2.5, the values of β and θ shall be as specified in Table B5.2-1. In using this table, ϵ_x shall be taken as the calculated longitudinal strain at the middepth of the member when the section is subjected to M_u , N_u , and V_u as shown in Figure B5.2-1.

For sections containing less transverse reinforcement than specified in Article 5.8.2.5, the values of β and θ shall be as specified in Table B5.2-2. In using this table, ϵ_x shall be taken as the largest calculated longitudinal strain which occurs within the web of the member when the section is subjected to N_u , M_u , and V_u as shown in Figure B5.2-2.

Unless more accurate calculations are made, ϵ_x shall be determined as:

- If the section contains at least the minimum transverse reinforcement as specified in Article 5.8.2.5:

$$\epsilon_x = \frac{\left(\frac{|M_u|}{d_v} + 0.5N_u + 0.5|V_u - V_p| \cot \theta - A_{ps}f_{po} \right)}{2(E_s A_s + E_p A_{ps})} \quad (\text{B5.2-1})$$

The initial value of ϵ_x should not be taken greater than 0.001.

- If the section contains less than the minimum transverse reinforcement as specified in Article 5.8.2.5:

$$\epsilon_x = \frac{\left(\frac{|M_u|}{d_v} + 0.5N_u + 0.5|V_u - V_p| \cot \theta - A_{ps}f_{po} \right)}{E_s A_s + E_p A_{ps}} \quad (\text{B5.2-2})$$

CB5.2

The shear resistance of a member may be determined by performing a detailed sectional analysis that satisfies the requirements of Article 5.8.3.1. Such an analysis (see Figure CB5.2-1) would show that the shear stresses are not uniform over the depth of the web and that the direction of the principal compressive stresses changes over the depth of the beam. The more direct procedure given herein assumes that the concrete shear stresses are uniformly distributed over an area b_v wide and d_v deep, that the direction of principal compressive stresses (defined by angle θ) remains constant over d_v , and that the shear strength of the section can be determined by considering the biaxial stress conditions at just one location in the web. See Figure CB5.2-2.

Members containing at least the minimum amount of transverse reinforcement have a considerable capacity to redistribute shear stresses from the most highly strained portion of the cross-section to the less highly strained portions. Because of this capacity to redistribute, it is appropriate to use the middepth of the member as the location at which the biaxial stress conditions are determined. Members that contain no transverse reinforcement, or contain less than the minimum amount of transverse reinforcement, have less capacity for shear stress redistribution. Hence, for such members, it is appropriate to perform the biaxial stress calculations at the location in the web subject to the highest longitudinal tensile strain; see Figure B5.2-2.

The longitudinal strain, ϵ_x , can be determined by the procedure illustrated in Figure CB5.2-3. The actual section is represented by an idealized section consisting of a flexural tension flange, a flexural compression flange, and a web. The area of the compression flange is taken as the area on the flexure compression side of the member, i.e., the total area minus the area of the tension flange as defined by A_c . After diagonal cracks have formed in the web, the shear force applied to the web concrete, $V_u - V_p$, will primarily be carried by diagonal compressive stresses in the web concrete. These

The initial value of ϵ_x should not be taken greater than 0.002.

- If the value of ϵ_x from Eqs. B5.2-1 or B5.2-2 is negative, the strain shall be taken as:

$$\epsilon_x = \frac{\left(\frac{|M_u|}{d_v} + 0.5N_u + 0.5|V_u - V_p| \cot \theta - A_{ps}f_{po} \right)}{2(E_c A_c + E_s A_s + E_p A_{ps})} \quad (\text{B5.2-3})$$

where:

- A_c = area of concrete on the flexural tension side of the member as shown in Figure B5.2-1 (in.²)
- A_{ps} = area of prestressing steel on the flexural tension side of the member, as shown in Figure B5.2-1 (in.²)
- A_s = area of nonprestressed steel on the flexural tension side of the member at the section under consideration, as shown in Figure B5.2-1. In calculating A_s for use in this equation, bars which are terminated at a distance less than their development length from the section under consideration shall be ignored (in.²)
- f_{po} = a parameter taken as modulus of elasticity of prestressing tendons multiplied by the locked-in difference in strain between the prestressing tendons and the surrounding concrete. For the usual levels of prestressing, a value of $0.7f_{pu}$ will be appropriate for both pretensioned and post-tensioned members (ksi)
- M_u = factored moment, not to be taken less than $V_u d_v$ (kip-in.)
- N_u = factored axial force, taken as positive if tensile and negative if compressive (kip)
- V_u = factored shear force (kip)

Within the transfer length, f_{po} shall be increased linearly from zero at the location where the bond between the strands and concrete commences to its full value at the end of the transfer length.

The flexural tension side of the member shall be taken as the half-depth containing the flexural tension zone, as illustrated in Figure B5.2-1.

The crack spacing parameter s_{xe} , used in Table B5.2-2, shall be determined as:

$$s_{xe} = s_x \frac{1.38}{a_g + 0.63} \leq 80 \text{ in.} \quad (\text{B5.2-4})$$

diagonal compressive stresses will result in a longitudinal compressive force in the web concrete of $(V_u - V_p) \cot \theta$. Equilibrium requires that this longitudinal compressive force in the web needs to be balanced by tensile forces in the two flanges, with half the force, that is $0.5(V_u - V_p) \cot \theta$, being taken by each flange. To avoid a trial and error iteration process, it is a convenient simplification to take this flange force due to shear as $V_u - V_p$. This amounts to taking $0.5 \cot \theta = 1.0$ in the numerator of Eqs. B5.2-1, B5.2-2, and B5.2-3. This simplification is not expected to cause a significant loss of accuracy. After the required axial forces in the two flanges are calculated, the resulting axial strains, ϵ_t and ϵ_c , can be calculated based on the axial force-axial strain relationship shown in Figure CB5.2-4.

For members containing at least the minimum amount of transverse reinforcement, ϵ_x can be taken as:

$$\epsilon_x = \frac{\epsilon_t + \epsilon_c}{2} \quad (\text{CB5.2-1})$$

where ϵ_t and ϵ_c are positive for tensile strains and negative for compressive strains. If, for a member subject to flexure, the strain ϵ_c is assumed to be negligibly small, then ϵ_x becomes one half of ϵ_t . This is the basis for the expression for ϵ_x given in Eq. B5.2-1. For members containing less than the minimum amount of transverse reinforcement, Eq. B5.2-2 makes the conservative simplification that ϵ_x is equal to ϵ_t .

In some situations, it will be more appropriate to determine ϵ_x using the more accurate procedure of Eq. CB5.2-1 rather than the simpler Eqs. B5.2-1 through B5.2-3. For example, the shear capacity of sections near the ends of precast, pretensioned simple beams made continuous for live load will be estimated in a very conservative manner by Eqs. B5.2-1 through B5.2-3 because, at these locations, the prestressing strands are located on the flexural compression side and, therefore, will not be included in A_{ps} . This will result in the benefits of prestressing not being accounted for by Eqs. B5.2-1 through B5.2-3.

Absolute value signs were added to Eqs. B5.2-1 through B5.2-3 in 2004. This notation replaced direction in the nomenclature to take M_u and V_u as positive values. For shear, absolute value signs in Eqs. B5.2-1 through B5.2-3 are needed to properly consider the effects due to V_u and V_p in sections containing a parabolic tendon path which may not change signs at the same location as shear demand, particularly at midspan.

For pretensioned members, f_{po} can be taken as the stress in the strands when the concrete is cast around them, i.e., approximately equal to the jacking stress. For post-tensioned members, f_{po} can be conservatively taken as the average stress in the tendons when the posttensioning is completed.

where:

- a_g = maximum aggregate size (in.)
 s_x = the lesser of either d_v or the maximum distance between layers of longitudinal crack control reinforcement, where the area of the reinforcement in each layer is not less than $0.003b_v s_x$, as shown in Figure B5.2-3 (in.)

In the evaluation of ϵ_x , β and θ , the following should be considered:

- M_u shall be taken as positive quantities and M_u shall not be taken less than $(V_u - V_p)d_v$.
- In calculating A_s and A_{ps} the area of bars or tendons which are terminated less than their development length from the section under consideration shall be reduced in proportion to their lack of full development.
- The value of ϵ_x calculated from Eqs. B5.2-2 and B5.2-3 should not be taken as less than -0.20×10^{-3} .
- For sections closer than d_v to the face of the support, the value of ϵ_x calculated at d_v from the face of the support may be used in evaluating β and θ .
- If the axial tension is large enough to crack the flexural compression face of the section, the resulting increase in ϵ_x shall be taken into account. In lieu of more accurate calculations, the value calculated from Eq. B5.2-2 should be doubled.
- It is permissible to determine β and θ from Tables B5.2-1 and B5.2-2 using a value of ϵ_x that is greater than that calculated from Eqs. B5.2-2 and B5.2-3; however, ϵ_x shall not be taken greater than 3.0×10^{-3} .

Note that in both Table B5.2-1 and Table B5.2-2, the values of β and θ given in a particular cell of the table can be applied over a range of values. Thus from Table B5.2-1, $\theta = 34.4$ degrees and $\beta = 2.26$ can be used provided that ϵ_x is not greater than 0.75×10^{-3} and v_u/f'_c is not greater than 0.125. Linear interpolation between the values given in the tables may be used, but is not recommended for hand calculations. Assuming a value of ϵ_x larger than the value calculated using Eqs. B5.2-1, B5.2-2, or B5.2-3, as appropriate, is permissible and will result in a higher value of θ and a lower value of β . Higher values of θ will typically require more transverse shear reinforcement, but will decrease the tension force required to be resisted by the longitudinal reinforcement. Figure CB5.2-5 illustrates the shear design process by means of a flow chart. This figure is based on the simplified assumption that $0.5 \cot \theta = 1.0$.

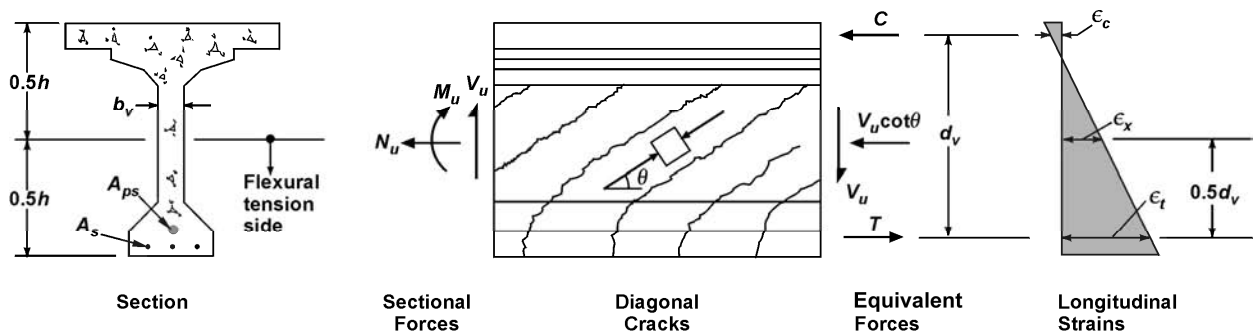

Figure B5.2-1—Illustration of Shear Parameters for Section Containing at Least the Minimum Amount of Transverse Reinforcement, $V_p = 0$

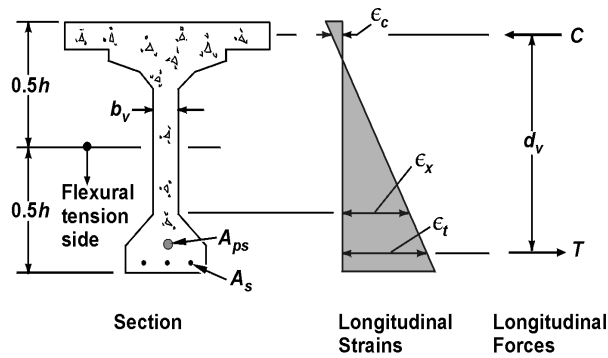

Figure B5.2-2—Longitudinal Strain, ϵ_x , for Sections Containing Less than the Minimum Amount of Transverse Reinforcement

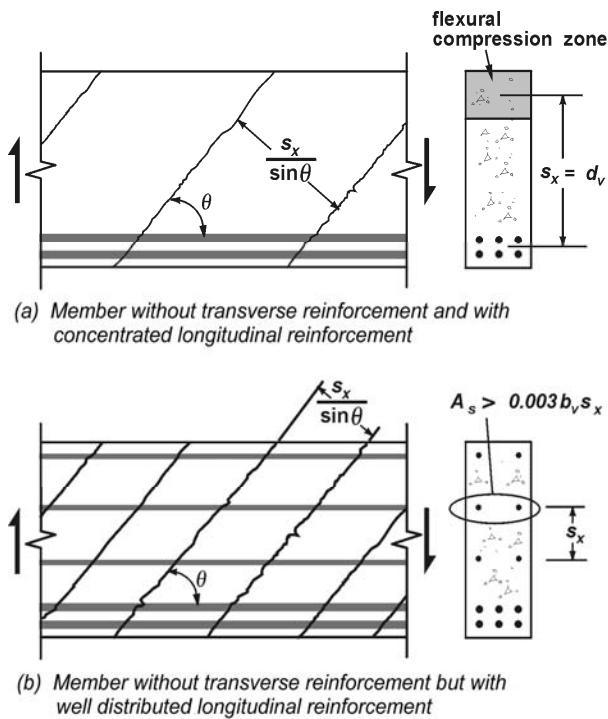

Figure B5.2-3—Definition of Crack Spacing Parameter, s_x

For sections containing a specified amount of transverse reinforcement, a shear-moment interaction diagram, see Figure CB5.2-6, can be calculated directly from the procedures in this Article. For a known concrete strength and a certain value of ϵ_x , each cell of Table B5.2-1 corresponds to a certain value of v_u/f'_c , i.e., a certain value of V_n . This value of V_n requires an amount of transverse reinforcement expressed in terms of the parameter $A_v f_y / (b_v s)$. The shear capacity corresponding to the provided shear reinforcement can be found by linearly interpolating between the values of V_n corresponding to two consecutive cells where one cell requires more transverse reinforcement than actually provided and the other cell requires less reinforcement than actually provided. After V_n and θ have been found in this manner, the corresponding moment capacity M_n can be found by calculating, from Eqs. B5.2-1 through B5.2-3 of the procedure to calculate a $V_n - M_n$ interaction diagram, it is appropriate to replace V_u by V_n , M_u by M_n , and N_u by N_n and to take the value of ϕ as 1.0. With an appropriate spreadsheet, the use of shear-moment interaction diagrams is a convenient way of performing shear design and evaluation.

The values of β and θ listed in Table B5.2-1 and Table B5.2-2 are based on calculating the stresses that can be transmitted across diagonally cracked concrete. As the cracks become wider, the stress that can be transmitted decreases. For members containing at least the minimum amount of transverse reinforcement, it is assumed that the diagonal cracks will be spaced about 12.0 in. apart. For members without transverse reinforcement, the spacing of diagonal cracks inclined at θ degrees to the longitudinal reinforcement is assumed to be $s_x / \sin \theta$, as shown in Figure B5.2-3. Hence, deeper members having larger values of s_x are calculated to have more widely spaced cracks and hence, cannot transmit such high shear stresses. The ability of the crack surfaces to transmit shear stresses is influenced by the aggregate size of the concrete. Members made from concretes that have a smaller maximum aggregate size will have a larger value of s_{xe} and hence, if there is no transverse reinforcement, will have a smaller shear strength.

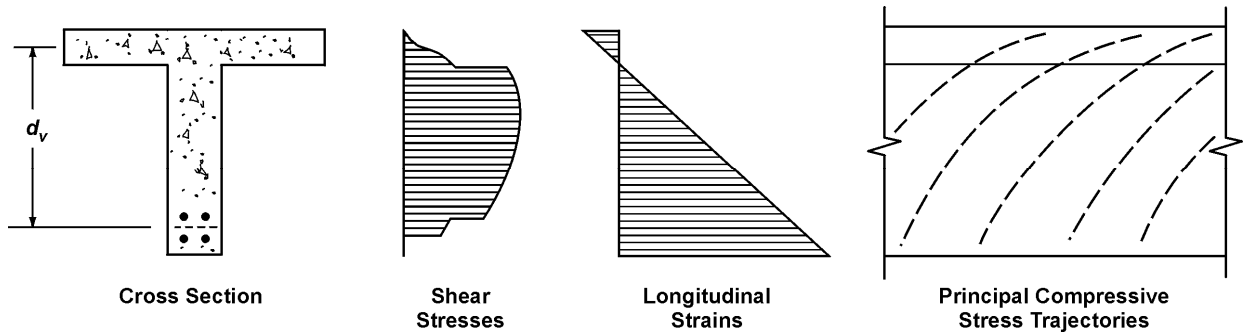

Figure CB5.2-1—Detailed Sectional Analysis to Determine Shear Resistance in Accordance with Article 5.8.3.1

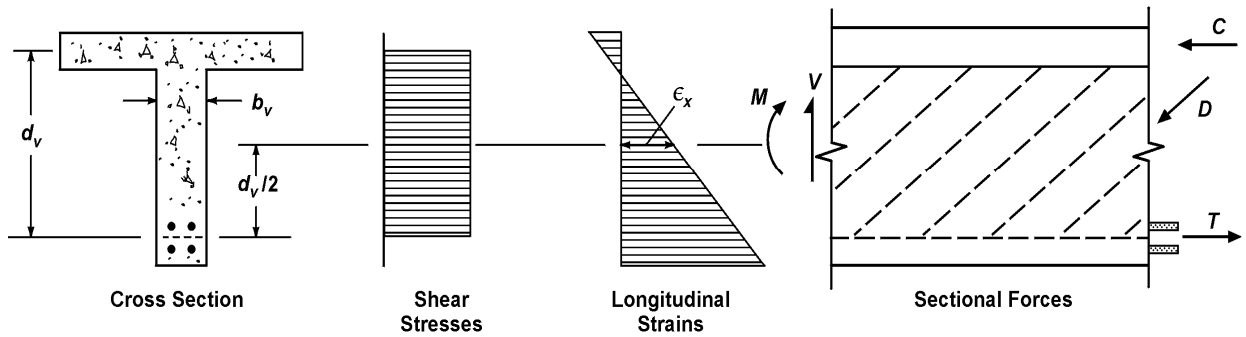

Figure CB5.2-2—More Direct Procedure to Determine Shear Resistance in Accordance with Article 5.8.3.4.2

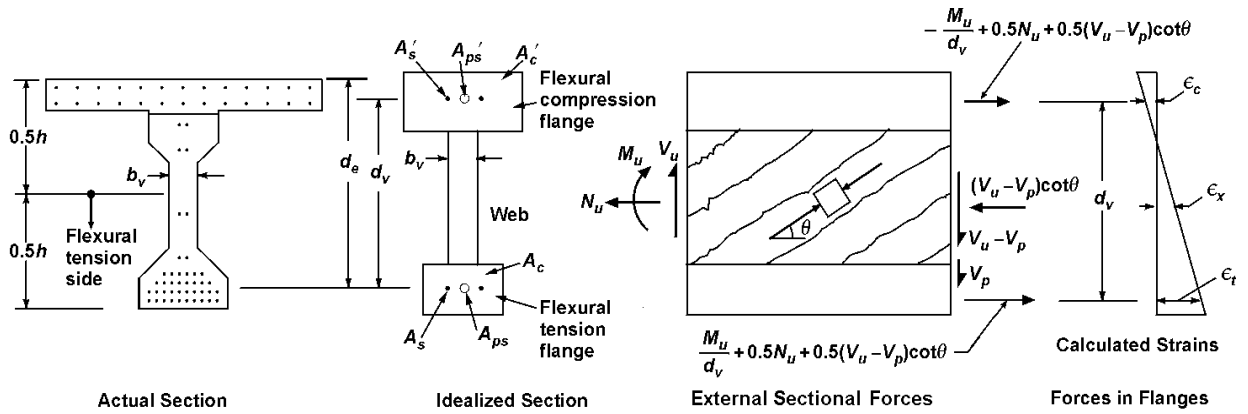

Figure CB5.2-3—More Accurate Calculation Procedure for Determining ϵ_x

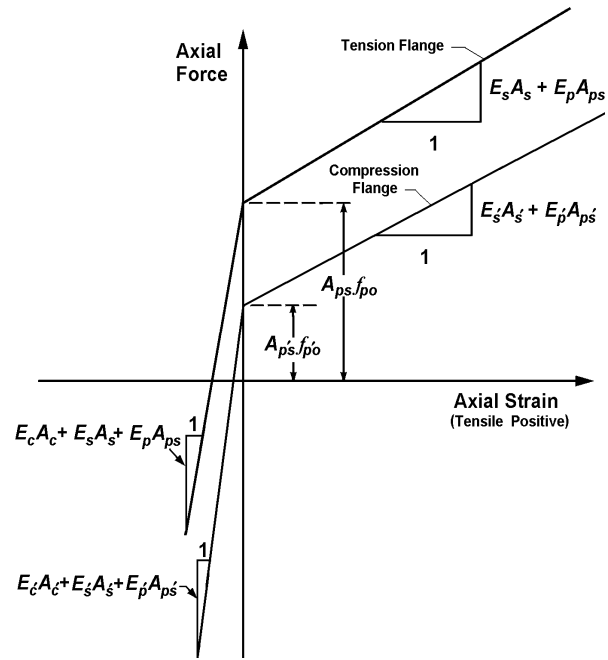

Figure CB5.2-4—Assumed Relations between Axial Force in Flange and Axial Strain of Flange

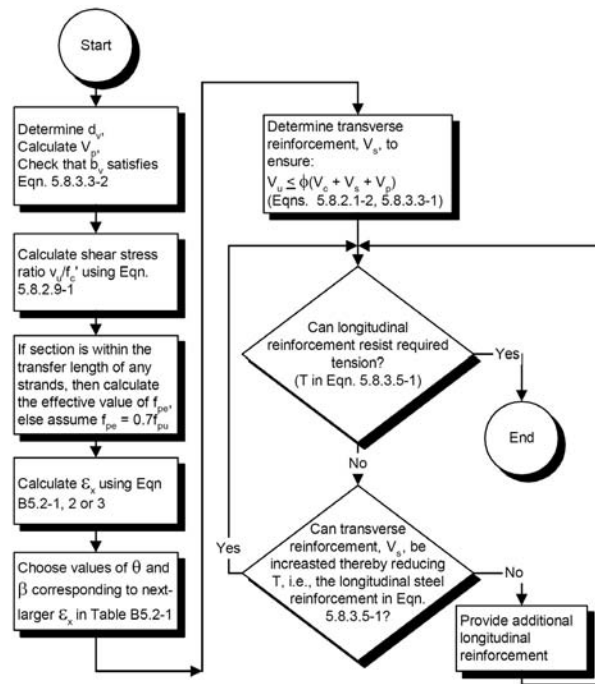

Figure CB5.2-5—Flow Chart for Shear Design of Section Containing at Least Minimum Transverse Reinforcement

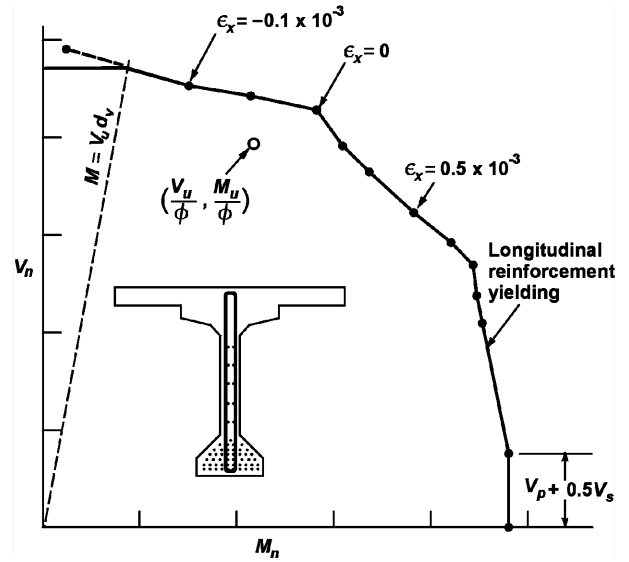

Figure CB5.2-6—Typical Shear-Moment Interaction Diagram

More details on the procedures used in deriving the tabulated values of θ and β are given in Collins and Mitchell (1991).

Table B5.2-1—Values of θ and β for Sections with Transverse Reinforcement

$\frac{v_u}{f'_c}$	$\epsilon_x \times 1,000$								
	≤ -0.20	≤ -0.10	≤ -0.05	≤ 0	≤ 0.125	≤ 0.25	≤ 0.50	≤ 0.75	≤ 1.00
≤ 0.075	22.3 6.32	20.4 4.75	21.0 4.10	21.8 3.75	24.3 3.24	26.6 2.94	30.5 2.59	33.7 2.38	36.4 2.23
≤ 0.100	18.1 3.79	20.4 3.38	21.4 3.24	22.5 3.14	24.9 2.91	27.1 2.75	30.8 2.50	34.0 2.32	36.7 2.18
≤ 0.125	19.9 3.18	21.9 2.99	22.8 2.94	23.7 2.87	25.9 2.74	27.9 2.62	31.4 2.42	34.4 2.26	37.0 2.13
≤ 0.150	21.6 2.88	23.3 2.79	24.2 2.78	25.0 2.72	26.9 2.60	28.8 2.52	32.1 2.36	34.9 2.21	37.3 2.08
≤ 0.175	23.2 2.73	24.7 2.66	25.5 2.65	26.2 2.60	28.0 2.52	29.7 2.44	32.7 2.28	35.2 2.14	36.8 1.96
≤ 0.200	24.7 2.63	26.1 2.59	26.7 2.52	27.4 2.51	29.0 2.43	30.6 2.37	32.8 2.14	34.5 1.94	36.1 1.79
≤ 0.225	26.1 2.53	27.3 2.45	27.9 2.42	28.5 2.40	30.0 2.34	30.8 2.14	32.3 1.86	34.0 1.73	35.7 1.64
≤ 0.250	27.5 2.39	28.6 2.39	29.1 2.33	29.7 2.33	30.6 2.12	31.3 1.93	32.8 1.70	34.3 1.58	35.8 1.50

Table B5.2-2—Values of θ and β for Sections with Less than Minimum Transverse Reinforcement

S_{xe} , in.	$\epsilon_x \times 1000$										
	≤ -0.20	≤ -0.10	≤ -0.05	≤ 0	≤ 0.125	≤ 0.25	≤ 0.50	≤ 0.75	≤ 1.00	≤ 1.50	≤ 2.00
≤ 5	25.4 6.36	25.5 6.06	25.9 5.56	26.4 5.15	27.7 4.41	28.9 3.91	30.9 3.26	32.4 2.86	33.7 2.58	35.6 2.21	37.2 1.96
≤ 10	27.6 5.78	27.6 5.78	28.3 5.38	29.3 4.89	31.6 4.05	33.5 3.52	36.3 2.88	38.4 2.50	40.1 2.23	42.7 1.88	44.7 1.65
≤ 15	29.5 5.34	29.5 5.34	29.7 5.27	31.1 4.73	34.1 3.82	36.5 3.28	39.9 2.64	42.4 2.26	44.4 2.01	47.4 1.68	49.7 1.46
≤ 20	31.2 4.99	31.2 4.99	31.2 4.99	32.3 4.61	36.0 3.65	38.8 3.09	42.7 2.46	45.5 2.09	47.6 1.85	50.9 1.52	53.4 1.31
≤ 30	34.1 4.46	34.1 4.46	34.1 4.46	34.2 4.43	38.9 3.39	42.3 2.82	46.9 2.19	50.1 1.84	52.6 1.60	56.3 1.30	59.0 1.10
≤ 40	36.6 4.06	36.6 4.06	36.6 4.06	36.6 4.06	41.2 3.20	45.0 2.62	50.2 2.00	53.7 1.66	56.3 1.43	60.2 1.14	63.0 0.95
≤ 60	40.8 3.50	40.8 3.50	40.8 3.50	40.8 3.50	44.5 2.92	49.2 2.32	55.1 1.72	58.9 1.40	61.8 1.18	65.8 0.92	68.6 0.75
≤ 80	44.3 3.10	44.3 3.10	44.3 3.10	44.3 3.10	47.1 2.71	52.3 2.11	58.7 1.52	62.8 1.21	65.7 1.01	69.7 0.76	72.4 0.62

**APPENDIX C5—UPPER LIMITS FOR ARTICLES
AFFECTED BY CONCRETE COMPRESSIVE STRENGTH**

Article ^a	Upper Limit, ksi	
	10.0	15.0 ^b
5.1—Scope		By exception
5.4.2.1—Compressive Strength		By exception
5.4.2.3—Shrinkage and Creep		X
5.4.2.4—Modulus of Elasticity		X
5.4.2.5—Poisson's Ratio	X	
5.4.2.6—Modulus of Rupture		X
C5.4.2.7—Tensile Strength	X	
5.5.3.1—General	X	
5.5.4.2—Resistance Factors	X	
5.6.3.3.3—Limiting Compressive Stress in Strut	X	
5.6.3.5—Proportioning of Node Regions	X	
5.6.3.6—Crack Control Reinforcement	X	
5.7.2—Assumptions for Strength and Extreme Event Limit States	X	
5.7.3.1—Stress in Prestressing Steel at Nominal Flexural Resistance	X	
5.7.3.2—Flexural Resistance	X	
5.7.3.3—Limits for Reinforcement	X	
5.7.3.4—Control of Cracking by Distribution of Reinforcement	X	
5.7.3.5—Moment Redistribution	X	
5.7.3.6—Deformations	X	
5.7.4.2—Limits for Reinforcement	X	
5.7.4.3—Approximate Evaluation of Slenderness Effects	X	
5.7.4.4—Factored Axial Resistance	X	
5.7.4.5—Biaxial Flexure	X	
5.7.4.6—Spirals and Ties	X	
5.7.4.7—Hollow Rectangular Compression Members	X	
5.7.5—Bearing	X	
5.8.2.1—General	X	
5.8.2.3—Transfer and Development Lengths	X	
5.8.2.7—Maximum Spacing of Transverse Reinforcement	X	
5.8.3—Sectional Design Model	X	
5.8.4—Interface Shear Transfer—Shear Friction	X	
5.8.6—Shear and Torsion for Segmental Box Girder Bridges	X	
5.9.1—General Design Considerations	X	
5.9.4—Stress Limits for Concrete	X	
5.9.5—Loss of Prestress		X
5.10.4.3—Effects of Curved Tendons	X	
5.10.6.2—Spirals	X	
5.10.6.3—Ties	X	
5.10.8—Shrinkage and Temperature Reinforcement	X	
5.10.9.3.1—Design Methods	X	
5.10.9.4—Application of the Strut-and-Tie Model to the Design of General Zone	X	
5.10.9.7.2—Bearing Resistance	X	
5.10.11.4—Seismic Zones 3 and 4	X	
5.11.2.1—Deformed Bars and Deformed Wire in Tension	X	
5.11.2.2—Deformed Bars in Compression	X	
5.11.2.3—Bundled Bars	X	

continued on next page

Article ^a	Upper Limit, ksi	
	10.0	15.0 ^b
5.11.2.4—Standard Hooks in Tension	X	
5.11.2.5—Welded Wire Fabric	X	
5.11.2.6—Shear Reinforcement	X	
5.11.4.1—General	X	
5.11.4.2—Bonded Strand	X	
5.11.4.3—Partially Debonded Strands	X	
5.11.5.3—Splices of Reinforcement in Tension	X	
5.11.5.5—Splices of Bars in Compression	X	
5.13.2.4—Brackets and Corbels	X	
5.13.2.5—Beam Ledges	X	
5.13.3.6—Shear in Slabs and Footings	X	
5.13.4.6—Seismic Requirements	X	
5.14.1—Beams and Girders	X	
5.14.2.3—Design	X	
5.14.5—Additional Provisions for Culverts	X	

Notes:

- a Applies to all subarticles of the listed Article
- b Normal weight concrete only

SECTION 6: STEEL STRUCTURES

TABLE OF CONTENTS

6.1—SCOPE 6-1

6.2—DEFINITIONS 6-1

6.3—NOTATION 6-10

6.4—MATERIALS 6-22

 6.4.1—Structural Steels 6-22

 6.4.2—Pins, Rollers, and Rockers 6-25

 6.4.3—Bolts, Nuts, and Washers 6-25

 6.4.3.1—Bolts 6-25

 6.4.3.2—Nuts 6-26

 6.4.3.2.1—Nuts Used with Structural Fasteners 6-26

 6.4.3.2.2—Nuts Used with Anchor Bolts 6-26

 6.4.3.3—Washers 6-26

 6.4.3.4—Alternative Fasteners 6-27

 6.4.3.5—Load Indicator Devices 6-27

 6.4.4—Stud Shear Connectors 6-27

 6.4.5—Weld Metal 6-27

 6.4.6—Cast Metal 6-28

 6.4.6.1—Cast Steel and Ductile Iron 6-28

 6.4.6.2—Malleable Castings 6-28

 6.4.6.3—Cast Iron 6-28

 6.4.7—Stainless Steel 6-28

 6.4.8—Cables 6-28

 6.4.8.1—Bright Wire 6-28

 6.4.8.2—Galvanized Wire 6-28

 6.4.8.3—Epoxy-Coated Wire 6-29

 6.4.8.4—Bridge Strand 6-29

6.5—LIMIT STATES 6-29

 6.5.1—General 6-29

 6.5.2—Service Limit State 6-29

 6.5.3—Fatigue and Fracture Limit State 6-29

 6.5.4—Strength Limit State 6-29

 6.5.4.1—General 6-29

 6.5.4.2—Resistance Factors 6-30

 6.5.5—Extreme Event Limit State 6-31

6.6—FATIGUE AND FRACTURE CONSIDERATIONS 6-31

 6.6.1—Fatigue 6-31

 6.6.1.1—General 6-31

 6.6.1.2—Load-Induced Fatigue 6-32

 6.6.1.2.1—Application 6-32

 6.6.1.2.2—Design Criteria 6-33

6.6.1.2.3—Detail Categories.....	6-34
6.6.1.2.4—Detailing to Reduce Constraint.....	6-48
6.6.1.2.5—Fatigue Resistance.....	6-48
6.6.1.3—Distortion-Induced Fatigue.....	6-51
6.6.1.3.1—Transverse Connection Plates.....	6-52
6.6.1.3.2—Lateral Connection Plates.....	6-52
6.6.1.3.3—Orthotropic Decks.....	6-53
6.6.2—Fracture.....	6-53
6.7—GENERAL DIMENSION AND DETAIL REQUIREMENTS.....	6-57
6.7.1—Effective Length of Span.....	6-57
6.7.2—Dead Load Camber.....	6-57
6.7.3—Minimum Thickness of Steel.....	6-59
6.7.4—Diaphragms and Cross-Frames.....	6-59
6.7.4.1—General.....	6-59
6.7.4.2—I-Section Members.....	6-60
6.7.4.3—Box Section Members.....	6-62
6.7.4.4—Trusses and Arches.....	6-64
6.7.5—Lateral Bracing.....	6-65
6.7.5.1—General.....	6-65
6.7.5.2—I-Section Members.....	6-65
6.7.5.3—Tub Section Members.....	6-66
6.7.5.4—Trusses.....	6-68
6.7.6—Pins.....	6-68
6.7.6.1—Location.....	6-68
6.7.6.2—Resistance.....	6-69
6.7.6.2.1—Combined Flexure and Shear.....	6-69
6.7.6.2.2—Bearing.....	6-69
6.7.6.3—Minimum Size Pin for Eyebars.....	6-69
6.7.6.4—Pins and Pin Nuts.....	6-70
6.7.7—Heat-Curved Rolled Beams and Welded Plate Girders.....	6-70
6.7.7.1—Scope.....	6-70
6.7.7.2—Minimum Radius of Curvature.....	6-70
6.7.7.3—Camber.....	6-71
6.8—TENSION MEMBERS.....	6-71
6.8.1—General.....	6-71
6.8.2—Tensile Resistance.....	6-72
6.8.2.1—General.....	6-72
6.8.2.2—Reduction Factor, U	6-73
6.8.2.3—Combined Tension and Flexure.....	6-76
6.8.3—Net Area.....	6-77
6.8.4—Limiting Slenderness Ratio.....	6-77
6.8.5—Builtup Members.....	6-78
6.8.5.1—General.....	6-78
6.8.5.2—Perforated Plates.....	6-78
6.8.6—Eyebars.....	6-78

6.8.6.1—Factored Resistance	6-78
6.8.6.2—Proportions.....	6-78
6.8.6.3—Packing	6-79
6.8.7—Pin-Connected Plates	6-79
6.8.7.1—General.....	6-79
6.8.7.2—Pin Plates	6-79
6.8.7.3—Proportions.....	6-80
6.8.7.4—Packing	6-80
6.9—COMPRESSION MEMBERS	6-80
6.9.1—General.....	6-80
6.9.2—Compressive Resistance.....	6-81
6.9.2.1—Axial Compression	6-81
6.9.2.2—Combined Axial Compression and Flexure	6-81
6.9.3—Limiting Slenderness Ratio	6-82
6.9.4—Noncomposite Members	6-82
6.9.4.1—Nominal Compressive Resistance.....	6-82
6.9.4.1.1—General	6-82
6.9.4.1.2—Elastic Flexural Buckling Resistance.....	6-86
6.9.4.1.3—Elastic Torsional Buckling and Flexural-Torsional Buckling Resistance.....	6-86
6.9.4.2—Nonslender and Slender Member Elements	6-88
6.9.4.2.1—Nonslender Member Elements.....	6-88
6.9.4.3—Built-up Members	6-93
6.9.4.3.1—General	6-93
6.9.4.3.2—Perforated Plates	6-94
6.9.4.4—Single-Angle Members	6-95
6.9.5—Composite Members	6-98
6.9.5.1—Nominal Compressive Resistance.....	6-98
6.9.5.2—Limitations	6-99
6.9.5.2.1—General	6-99
6.9.5.2.2—Concrete-Filled Tubes	6-99
6.9.5.2.3—Concrete-Encased Shapes	6-99
6.10—I-SECTION FLEXURAL MEMBERS	6-100
6.10.1—General.....	6-100
6.10.1.1—Composite Sections.....	6-102
6.10.1.1.1—Stresses	6-102
6.10.1.1.1a—Sequence of Loading	6-102
6.10.1.1.1b—Stresses for Sections in Positive Flexure	6-102
6.10.1.1.1c—Stresses for Sections in Negative Flexure	6-103
6.10.1.1.1d—Concrete Deck Stresses	6-103
6.10.1.1.1e—Effective Width of Concrete Deck.....	6-103
6.10.1.2—Noncomposite Sections.....	6-103
6.10.1.3—Hybrid Sections.....	6-104
6.10.1.4—Variable Web Depth Members	6-104
6.10.1.5—Stiffness	6-106

6.10.1.6—Flange Stresses and Member Bending Moments	6-106
6.10.1.7—Minimum Negative Flexure Concrete Deck Reinforcement	6-108
6.10.1.8—Net Section Fracture.....	6-110
6.10.1.9—Web Bend-Buckling Resistance.....	6-110
6.10.1.9.1—Webs without Longitudinal Stiffeners	6-110
6.10.1.9.2—Webs with Longitudinal Stiffeners	6-112
6.10.1.10—Flange-Strength Reduction Factors	6-113
6.10.1.10.1—Hybrid Factor, R_h	6-113
6.10.1.10.2—Web Load-Shedding Factor, R_b	6-114
6.10.2—Cross-Section Proportion Limits	6-118
6.10.2.1—Web Proportions	6-118
6.10.2.1.1—Webs without Longitudinal Stiffeners	6-118
6.10.2.1.2—Webs with Longitudinal Stiffeners	6-119
6.10.2.2—Flange Proportions	6-119
6.10.3—Constructibility.....	6-120
6.10.3.1—General	6-120
6.10.3.2—Flexure	6-121
6.10.3.2.1—Discretely Braced Flanges in Compression.....	6-121
6.10.3.2.2—Discretely Braced Flanges in Tension.....	6-123
6.10.3.2.3 Continuously Braced Flanges in Tension or Compression	6-123
6.10.3.2.4—Concrete Deck.....	6-123
6.10.3.3—Shear	6-124
6.10.3.4—Deck Placement.....	6-124
6.10.3.5—Dead Load Deflections.....	6-126
6.10.4—Service Limit State	6-127
6.10.4.1—Elastic Deformations.....	6-127
6.10.4.2—Permanent Deformations.....	6-127
6.10.4.2.1—General.....	6-127
6.10.4.2.2—Flexure	6-127
6.10.5—Fatigue and Fracture Limit State	6-130
6.10.5.1—Fatigue.....	6-130
6.10.5.2—Fracture	6-130
6.10.5.3—Special Fatigue Requirement for Webs.....	6-130
6.10.6—Strength Limit State.....	6-131
6.10.6.1—General	6-131
6.10.6.2—Flexure	6-132
6.10.6.2.1—General.....	6-132
6.10.6.2.2—Composite Sections in Positive Flexure.....	6-132
6.10.6.2.3—Composite Sections in Negative Flexure and Noncomposite Sections	6-134
6.10.6.3—Shear	6-136
6.10.6.4—Shear Connectors	6-136
6.10.7—Flexural Resistance—Composite Sections in Positive Flexure	6-136
6.10.7.1—Compact Sections.....	6-136
6.10.7.1.1—General.....	6-136
6.10.7.1.2—Nominal Flexural Resistance	6-137
6.10.7.2—Noncompact Sections.....	6-139

6.10.7.2.1—General	6-139
6.10.7.2.2—Nominal Flexural Resistance	6-140
6.10.7.3—Ductility Requirement.....	6-140
6.10.8—Flexural Resistance—Composite Sections in Negative Flexure and Noncomposite Sections	6-141
6.10.8.1—General.....	6-141
6.10.8.1.1—Discretely Braced Flanges in Compression	6-141
6.10.8.1.2—Discretely Braced Flanges in Tension	6-141
6.10.8.1.3—Continuously Braced Flanges in Tension or Compression	6-141
6.10.8.2 Compression-Flange Flexural Resistance	6-142
6.10.8.2.1—General	6-142
6.10.8.2.2—Local Buckling Resistance.....	6-143
6.10.8.2.3—Lateral Torsional Buckling Resistance	6-144
6.10.8.3—Tension-Flange Flexural Resistance	6-150
6.10.9—Shear Resistance	6-151
6.10.9.1—General.....	6-151
6.10.9.2—Nominal Resistance of Unstiffened Webs	6-152
6.10.9.3—Nominal Resistance of Stiffened Webs.....	6-152
6.10.9.3.1—General	6-152
6.10.9.3.2—Interior Panels.....	6-153
6.10.9.3.3—End Panels	6-154
6.10.10—Shear Connectors	6-154
6.10.10.1—General.....	6-154
6.10.10.1.1—Types	6-155
6.10.10.1.2—Pitch.....	6-155
6.10.10.1.3—Transverse Spacing	6-156
6.10.10.1.4—Cover and Penetration.....	6-157
6.10.10.2—Fatigue Resistance	6-157
6.10.10.3—Special Requirements for Points of Permanent Load Contraflexure.....	6-158
6.10.10.4—Strength Limit State	6-158
6.10.10.4.1—General	6-158
6.10.10.4.2—Nominal Shear Force	6-159
6.10.10.4.3—Nominal Shear Resistance	6-161
6.10.11—Stiffeners.....	6-161
6.10.11.1—Transverse Stiffeners	6-161
6.10.11.1.1—General	6-161
6.10.11.1.2—Projecting Width.....	6-162
6.10.11.1.3—Moment of Inertia	6-162
6.10.11.2—Bearing Stiffeners	6-165
6.10.11.2.1—General	6-165
6.10.11.2.2—Projecting Width.....	6-165
6.10.11.2.3—Bearing Resistance.....	6-165
6.10.11.2.4—Axial Resistance of Bearing Stiffeners	6-166
6.10.11.2.4a—General.....	6-166
6.10.11.2.4b—Effective Section.....	6-166
6.10.11.3—Longitudinal Stiffeners	6-166
6.10.11.3.1—General	6-166

6.10.11.3.2—Projecting Width	6-169
6.10.11.3.3—Moment of Inertia and Radius of Gyration	6-169
6.10.12—Cover Plates	6-170
6.10.12.1—General	6-170
6.10.12.2—End Requirements	6-170
6.10.12.2.1—General	6-170
6.10.12.2.2—Welded Ends	6-171
6.10.12.2.3—Bolted Ends	6-171
6.11—BOX-SECTION FLEXURAL MEMBERS	6-171
6.11.1—General	6-171
6.11.1.1—Stress Determinations	6-173
6.11.1.2—Bearings	6-176
6.11.1.3—Flange-to-Web Connections	6-176
6.11.1.4—Access and Drainage	6-177
6.11.2—Cross-Section Proportion Limits	6-177
6.11.2.1—Web Proportions	6-177
6.11.2.1.1—General	6-177
6.11.2.1.2—Webs without Longitudinal Stiffeners	6-178
6.11.2.1.3—Webs with Longitudinal Stiffeners	6-178
6.11.2.2—Flange Proportions	6-178
6.11.2.3—Special Restrictions on Use of Live Load Distribution Factor for Multiple Box Sections.....	6-178
6.11.3—Constructibility	6-179
6.11.3.1—General	6-179
6.11.3.2—Flexure	6-179
6.11.3.3—Shear	6-182
6.11.4—Service Limit State	6-182
6.11.5—Fatigue and Fracture Limit State	6-183
6.11.6—Strength Limit State.....	6-185
6.11.6.1—General	6-185
6.11.6.2—Flexure	6-185
6.11.6.2.1—General	6-185
6.11.6.2.2—Sections in Positive Flexure	6-185
6.11.6.2.3—Sections in Negative Flexure	6-186
6.11.6.3—Shear	6-186
6.11.6.4—Shear Connectors	6-186
6.11.7—Flexural Resistance—Sections in Positive Flexure	6-187
6.11.7.1—Compact Sections.....	6-187
6.11.7.1.1—General	6-187
6.11.7.1.2—Nominal Flexural Resistance	6-187
6.11.7.2—Noncompact Sections	6-187
6.11.7.2.1—General	6-187
6.11.7.2.2—Nominal Flexural Resistance	6-188
6.11.8—Flexural Resistance—Sections in Negative Flexure.....	6-189
6.11.8.1—General	6-189
6.11.8.1.1—Box Flanges in Compression	6-189

6.11.8.1.2—Continuously Braced Flanges in Tension	6-190
6.11.8.2—Flexural Resistance of Box Flanges in Compression.....	6-190
6.11.8.2.1—General	6-190
6.11.8.2.2—Unstiffened Flanges	6-190
6.11.8.2.3—Longitudinally Stiffened Flanges.....	6-192
6.11.8.3—Tension-Flange Flexural Resistance	6-193
6.11.9—Shear Resistance	6-194
6.11.10—Shear Connectors	6-194
6.11.11—Stiffeners.....	6-195
6.11.11.1—Web Stiffeners	6-195
6.11.11.2—Longitudinal Compression-Flange Stiffeners	6-196
6.12—MISCELLANEOUS FLEXURAL MEMBERS	6-199
6.12.1—General.....	6-199
6.12.1.1—Scope	6-199
6.12.1.2—Strength Limit State	6-199
6.12.1.2.1—Flexure.....	6-199
6.12.1.2.2—Combined Flexure and Axial Load.....	6-199
6.12.1.2.3—Shear.....	6-200
6.12.1.2.3a—General.....	6-200
6.12.1.2.3b—Square and Rectangular HSS.....	6-200
6.12.1.2.3c—Circular Tubes	6-200
6.12.2—Nominal Flexural Resistance	6-201
6.12.2.1—General.....	6-201
6.12.2.2—Noncomposite Members	6-201
6.12.2.2.1—I- and H-Shaped Members.....	6-201
6.12.2.2.2—Box-Shaped Members.....	6-202
6.12.2.2.3—Circular Tubes	6-204
6.12.2.2.4—Teels and Double Angles.....	6-205
6.12.2.2.5—Channels	6-207
6.12.2.2.6—Single Angles.....	6-209
6.12.2.2.7—Rectangular Bars and Solid Rounds	6-210
6.12.2.3—Composite Members.....	6-211
6.12.2.3.1—Concrete-Encased Shapes.....	6-211
6.12.2.3.2—Concrete-Filled Tubes.....	6-212
6.12.3—Nominal Shear Resistance of Composite Members	6-212
6.12.3.1—Concrete-Encased Shapes.....	6-212
6.12.3.2—Concrete-Filled Tubes.....	6-213
6.12.3.2.1—Rectangular Tubes	6-213
6.12.3.2.2—Circular Tubes	6-213
6.13—CONNECTIONS AND SPLICES.....	6-213
6.13.1—General.....	6-213
6.13.2—Bolted Connections.....	6-214
6.13.2.1—General.....	6-214
6.13.2.1.1—Slip-Critical Connections.....	6-214

6.13.2.1.2—Bearing-Type Connections.....	6-215
6.13.2.2—Factored Resistance.....	6-215
6.13.2.3—Bolts, Nuts, and Washers.....	6-216
6.13.2.3.1—Bolts and Nuts.....	6-216
6.13.2.3.2—Washers.....	6-216
6.13.2.4—Holes.....	6-217
6.13.2.4.1—Type.....	6-217
6.13.2.4.1a—General.....	6-217
6.13.2.4.1b—Oversize Holes.....	6-217
6.13.2.4.1c—Short-Slotted Holes.....	6-217
6.13.2.4.1d—Long-Slotted Holes.....	6-217
6.13.2.4.2—Size.....	6-217
6.13.2.5—Size of Bolts.....	6-218
6.13.2.6—Spacing of Bolts.....	6-218
6.13.2.6.1—Minimum Spacing and Clear Distance.....	6-218
6.13.2.6.2—Maximum Spacing for Sealing Bolts.....	6-218
6.13.2.6.3—Maximum Pitch for Stitch Bolts.....	6-219
6.13.2.6.4—Maximum Pitch for Stitch Bolts at the End of Compression Members.....	6-219
6.13.2.6.5—End Distance.....	6-219
6.13.2.6.6—Edge Distances.....	6-220
6.13.2.7—Shear Resistance.....	6-220
6.13.2.8—Slip Resistance.....	6-221
6.13.2.9—Bearing Resistance at Bolt Holes.....	6-224
6.13.2.10—Tensile Resistance.....	6-225
6.13.2.10.1—General.....	6-225
6.13.2.10.2—Nominal Tensile Resistance.....	6-225
6.13.2.10.3—Fatigue Resistance.....	6-225
6.13.2.10.4—Prying Action.....	6-225
6.13.2.11—Combined Tension and Shear.....	6-226
6.13.2.12—Shear Resistance of Anchor Bolts.....	6-226
6.13.3—Welded Connections.....	6-227
6.13.3.1—General.....	6-227
6.13.3.2—Factored Resistance.....	6-227
6.13.3.2.1—General.....	6-227
6.13.3.2.2—Complete Penetration Groove-Welded Connections.....	6-227
6.13.3.2.2a—Tension and Compression.....	6-227
6.13.3.2.2b—Shear.....	6-227
6.13.3.2.3—Partial Penetration Groove-Welded Connections.....	6-228
6.13.3.2.3a—Tension or Compression.....	6-228
6.13.3.2.3b—Shear.....	6-228
6.13.3.2.4—Fillet-Welded Connections.....	6-228
6.13.3.2.4a—Tension and Compression.....	6-228
6.13.3.2.4b—Shear.....	6-229
6.13.3.3—Effective Area.....	6-229
6.13.3.4—Size of Fillet Welds.....	6-229
6.13.3.5—Minimum Effective Length of Fillet Welds.....	6-230

6.13.3.6—Fillet Weld End Returns.....	6-230
6.13.3.7—Seal Welds	6-230
6.13.4—Block Shear Rupture Resistance	6-230
6.13.5—Connection Elements	6-231
6.13.5.1—General.....	6-231
6.13.5.2—Tension	6-231
6.13.5.3—Shear	6-232
6.13.6—Splices.....	6-232
6.13.6.1—Bolted Splices	6-232
6.13.6.1.1—General	6-232
6.13.6.1.2—Tension Members	6-232
6.13.6.1.3—Compression Members	6-233
6.13.6.1.4—Flexural Members	6-233
6.13.6.1.4a—General.....	6-233
6.13.6.1.4b—Web Splices.....	6-234
6.13.6.1.4c—Flange Splices.....	6-238
6.13.6.1.5—Fillers	6-241
6.13.6.2—Welded Splices	6-242
6.13.7—Rigid Frame Connections.....	6-243
6.13.7.1—General.....	6-243
6.13.7.2—Webs	6-243
6.14—PROVISIONS FOR STRUCTURE TYPES	6-244
6.14.1—Through-Girder Spans.....	6-244
6.14.2—Trusses	6-244
6.14.2.1—General.....	6-244
6.14.2.2—Truss Members	6-245
6.14.2.3—Secondary Stresses.....	6-245
6.14.2.4—Diaphragms.....	6-245
6.14.2.5—Camber.....	6-245
6.14.2.6—Working Lines and Gravity Axes	6-245
6.14.2.7—Portal and Sway Bracing.....	6-246
6.14.2.7.1—General	6-246
6.14.2.7.2—Through-Truss Spans.....	6-246
6.14.2.7.3—Deck Truss Spans	6-246
6.14.2.8—Gusset Plates.....	6-246
6.14.2.9—Half Through-Trusses	6-247
6.14.2.10—Factored Resistance	6-247
6.14.3—Orthotropic Deck Superstructures	6-247
6.14.3.1—General.....	6-247
6.14.3.2—Decks in Global Compression.....	6-247
6.14.3.2.1—General	6-247
6.14.3.2.2—Local Buckling	6-248
6.14.3.2.3—Panel Buckling.....	6-248
6.14.3.3—Effective Width of Deck	6-249
6.14.3.4—Superposition of Global and Local Effects	6-249

6.14.4—Solid Web Arches	6-249
6.14.4.1—Moment Amplification for Deflection.....	6-249
6.14.4.2—Web Slenderness	6-249
6.14.4.3—Flange Stability	6-250
6.15—PILES	6-250
6.15.1—General.....	6-250
6.15.2—Structural Resistance	6-250
6.15.3—Compressive Resistance	6-252
6.15.3.1—Axial Compression.....	6-252
6.15.3.2—Combined Axial Compression and Flexure.....	6-252
6.15.3.3—Buckling.....	6-252
6.15.4—Maximum Permissible Driving Stresses.....	6-252
6.16—PROVISIONS FOR SEISMIC DESIGN.....	6-252
6.16.1—General.....	6-252
6.16.2—Materials.....	6-254
6.16.3—Design Requirements for Seismic Zone 1	6-254
6.16.4—Design Requirements for Seismic Zones 2, 3, or 4	6-254
6.16.4.1—General	6-254
6.16.4.2—Deck	6-255
6.16.4.3—Shear Connectors	6-256
6.16.4.4—Elastic Superstructures	6-259
6.17—REFERENCES.....	6-259
APPENDIX A6—FLEXURAL RESISTANCE OF STRAIGHT COMPOSITE I-SECTIONS IN NEGATIVE FLEXURE AND STRAIGHT NONCOMPOSITE I-SECTIONS WITH COMPACT OR NONCOMPACT WEBS	6-271
A6.1—GENERAL	6-271
A6.1.1—Sections with Discretely Braced Compression Flanges.....	6-272
A6.1.2—Sections with Discretely Braced Tension Flanges.....	6-273
A6.1.3 Sections with Continuously Braced Compression Flanges	6-274
A6.1.4 Sections with Continuously Braced Tension Flanges.....	6-274
A6.2—WEB PLASTIFICATION FACTORS	6-274
A6.2.1—Compact Web Sections	6-274
A6.2.2—Noncompact Web Sections.....	6-275
A6.3—FLEXURAL RESISTANCE BASED ON THE COMPRESSION FLANGE.....	6-277
A6.3.1—General	6-277
A6.3.2—Local Buckling Resistance	6-278
A6.3.3—Lateral Torsional Buckling Resistance	6-279
A6.4—FLEXURAL RESISTANCE BASED ON TENSION FLANGE YIELDING	6-282
APPENDIX B6—MOMENT REDISTRIBUTION FROM INTERIOR-PIER I-SECTIONS IN STRAIGHT CONTINUOUS-SPAN BRIDGES.....	6-283

B6.1—GENERAL	6-283
B6.2—SCOPE	6-283
B6.2.1—Web Proportions.....	6-284
B6.2.2—Compression Flange Proportions.....	6-284
B6.2.3—Section Transitions.....	6-285
B6.2.4—Compression Flange Bracing	6-285
B6.2.5—Shear.....	6-285
B6.2.6—Bearing Stiffeners.....	6-285
B6.3—SERVICE LIMIT STATE	6-286
B6.3.1—General	6-286
B6.3.2—Flexure	6-286
B6.3.2.1—Adjacent to Interior-Pier Sections	6-286
B6.3.2.2—At All Other Locations	6-286
B6.3.3—Redistribution Moments	6-287
B6.3.3.1—At Interior-Pier Sections.....	6-287
B6.3.3.2—At All Other Locations	6-287
B6.4—STRENGTH LIMIT STATE.....	6-288
B6.4.1—Flexural Resistance	6-288
B6.4.1.1—Adjacent to Interior-Pier Sections	6-288
B6.4.1.2—At All Other Locations	6-288
B6.4.2—Redistribution Moments	6-288
B6.4.2.1—At Interior-Pier Sections.....	6-288
B6.4.2.2—At All Other Sections	6-289
B6.5—EFFECTIVE PLASTIC MOMENT	6-289
B6.5.1—Interior-Pier Sections with Enhanced Moment-Rotation Characteristics	6-289
B6.5.2—All Other Interior-Pier Sections.....	6-290
B6.6—REFINED METHOD	6-290
B6.6.1—General	6-290
B6.6.2—Nominal Moment-Rotation Curves	6-292
APPENDIX C6—BASIC STEPS FOR STEEL BRIDGE SUPERSTRUCTURES	6-295
C6.1—GENERAL	6-295
C6.2—GENERAL CONSIDERATIONS.....	6-295
C6.3—SUPERSTRUCTURE DESIGN.....	6-295
C6.4—FLOWCHARTS FOR FLEXURAL DESIGN OF I-SECTIONS.....	6-300
C6.4.1—Flowchart for LRFD Article 6.10.3	6-300
C6.4.2—Flowchart for LRFD Article 6.10.4.....	6-301
C6.4.3—Flowchart for LRFD Article 6.10.5	6-302
C6.4.4—Flowchart for LRFD Article 6.10.6.....	6-303
C6.4.5—Flowchart for LRFD Article 6.10.7.....	6-304

C6.4.6—Flowchart for LRFD Article 6.10.8	6-305
C6.4.7—Flowchart for Appendix A6	6-307
C6.4.8—Flowchart for Article D6.4.1	6-309
C6.4.9—Flowchart for Article D6.4.2	6-310
C6.4.10—Moment Gradient Modifier, C_b (Sample Cases)	6-311
 APPENDIX D6—FUNDAMENTAL CALCULATIONS FOR FLEXURAL MEMBERS	 6-313
D6.1—PLASTIC MOMENT	6-313
D6.2—YIELD MOMENT	6-315
D6.2.1—Noncomposite Sections	6-315
D6.2.2—Composite Sections in Positive Flexure	6-316
D6.2.3—Composite Sections in Negative Flexure	6-316
D6.2.4—Sections with Cover Plates	6-317
D6.3—DEPTH OF THE WEB IN COMPRESSION	6-317
D6.3.1—In the Elastic Range (D_c)	6-317
D6.3.2—At Plastic Moment (D_{cp})	6-318
D6.4—LATERAL TORSIONAL BUCKLING EQUATIONS FOR $C_B > 1.0$, WITH EMPHASIS ON UNBRACED LENGTH REQUIREMENTS FOR DEVELOPMENT OF THE MAXIMUM FLEXURAL RESISTANCE	6-319
D6.4.1—By the Provisions of Article 6.10.8.2.3	6-319
D6.4.2—By the Provisions of Article A6.3.3	6-320
D6.5—CONCENTRATED LOADS APPLIED TO WEBS WITHOUT BEARING STIFFENERS	6-320
D6.5.1—General	6-320
D6.5.2—Web Local Yielding	6-321
D6.5.3—Web Crippling	6-321

STEEL STRUCTURES

6.1—SCOPE

This Section covers the design of steel components, splices and connections for straight or horizontally curved beam and girder structures, frames, trusses and arches, cable-stayed and suspension systems, and metal deck systems, as applicable.

When applied to curved steel girders, these provisions shall be taken to apply to the design and construction of highway superstructures with horizontally curved steel I-shaped or single-cell box-shaped longitudinal girders with radii greater than 100 ft. Exceptions to this limit shall be based on a thorough evaluation of the application of the bridge under consideration consistent with basic structural fundamentals.

A brief outline for the design of steel girder bridges is presented in Appendix C6.

C6.1

The LRFD provisions have no span limit. There has been a history of construction problems associated with curved bridges with spans greater than about 350 ft. Large girder self-weight may cause critical stresses and deflections during erection when the steel work is incomplete. Large lateral deflections and girder rotations associated with longer spans tend to make it difficult to fit up cross-frames. Large curved steel bridges have been built successfully; however, these bridges deserve special considerations such as the possible need for more than one temporary support in large spans.

Most of the provisions for proportioning main elements are grouped by structural action:

- Tension and combined tension and flexure (Article 6.8)
- Compression and combined compression and flexure (Article 6.9)
- Flexure, flexural shear, and torsion:
 - I-sections (Article 6.10)
 - Box sections (Article 6.11)
 - Miscellaneous sections (Article 6.12)

Provisions for connections and splices are contained in Article 6.13.

Article 6.14 contains provisions specific to particular assemblages or structural types, e.g., through-girder spans, trusses, orthotropic deck systems, and arches.

6.2—DEFINITIONS

Abutment—An end support for a bridge superstructure.

Aspect Ratio—In any rectangular configuration, the ratio of the lengths of the sides.

Beam—A structural member whose primary function is to transmit loads to the support primarily through flexure and shear. Generally, this term is used when the component is made of rolled shapes.

Beam-Column—A structural member whose primary function is to resist both axial loads and bending moments.

Bend-Buckling Resistance—The maximum load that can be carried by a web plate without experiencing theoretical elastic local buckling due to bending.

Biaxial Bending—Simultaneous bending of a member or component about two perpendicular axes.

Bifurcation—The phenomenon whereby an ideally straight or flat member or component under compression may either assume a deflected position or may remain undeflected, or an ideally straight member under flexure may either deflect and twist out-of-plane or remain in its in-plane deflected position.

Bifurcation Analysis—An analysis used to determine the buckling or bifurcation load.

Block Shear Rupture—Failure of a bolted web connection of coped beams or any tension connection by the tearing out of a portion of a plate along the perimeter of the connecting bolts.

Bolt Assembly—The bolt, nut(s), and washer(s).

Box Flange—A flange that is connected to two webs. The flange may be a flat unstiffened plate, a stiffened plate or a flat plate with reinforced concrete attached to the plate with shear connectors.

Bracing Member—A member intended to brace a main member or part thereof against lateral movement.

Buckling Load—The load at which an ideally straight member or component under compression assumes a deflected position.

Built-Up Member—A member made of structural steel elements that are welded, bolted or riveted together.

Charpy V-Notch Impact Requirement—The minimum energy required to be absorbed in a Charpy V-notch test conducted at a specified temperature.

Charpy V-Notch Test—An impact test complying with AASHTO T 243M/T 243 (ASTM A673/A673M).

Clear Distance of Bolts—The distance between edges of adjacent bolt holes.

Clear End Distance of Bolts—The distance between the edge of a bolt hole and the end of a member.

Closed-Box Section—A flexural member having a cross-section composed of two vertical or inclined webs which has at least one completely enclosed cell. A closed-section member is effective in resisting applied torsion by developing shear flow in the webs and flanges.

Collapse Load—That load that can be borne by a structural member or structure just before failure becomes apparent.

Compact Flange—For a composite section in negative flexure or a noncomposite section, a discretely braced compression flange with a slenderness at or below which the flange can sustain sufficient strains such that the maximum potential flexural resistance is achieved prior to flange local buckling having a statistically significant influence on the response, provided that sufficient lateral bracing requirements are satisfied to develop the maximum potential flexural resistance.

Compact Section—A composite section in positive flexure satisfying specific steel grade, web slenderness and ductility requirements that is capable of developing a nominal resistance exceeding the moment at first yield, but not to exceed the plastic moment.

Compact Unbraced Length—For a composite section in negative flexure or a noncomposite section, the limiting unbraced length of a discretely braced compression flange at or below which the maximum potential flexural resistance can be achieved prior to lateral torsional buckling having a statistically significant influence on the response, provided that sufficient flange slenderness requirements are satisfied to develop the maximum potential flexural resistance.

Compact Web—For a composite section in negative flexure or a noncomposite section, a web with a slenderness at or below which the section can achieve a maximum flexural resistance equal to the plastic moment prior to web bend-buckling having a statistically significant influence on the response, provided that sufficient steel grade, ductility, flange slenderness and/or lateral bracing requirements are satisfied.

Component—A constituent part of a structure.

Composite Beam—A steel beam connected to a deck so that they respond to force effects as a unit.

Composite Column—A structural compression member consisting of either structural shapes embedded in concrete, or a steel tube filled with concrete designed to respond to force effects as a unit.

Composite Girder—A steel flexural member connected to a concrete slab so that the steel element and the concrete slab, or the longitudinal reinforcement within the slab, respond to force effects as a unit.

Connection—A weld or arrangement of bolts that transfers normal and/or shear stresses from one element to another.

Constant Amplitude Fatigue Threshold—The nominal stress range below which a particular detail can withstand an infinite number of repetitions without fatigue failure.

Continuously Braced Flange—A flange encased in concrete or anchored by shear connectors for which flange lateral bending effects need not be considered. A continuously braced flange in compression is also assumed not to be subject to local or lateral torsional buckling.

Controlling Flange—Top or bottom flange for the smaller section at a point of splice, whichever flange has the maximum ratio of the elastic flexural stress at its midthickness due to the factored loads to its factored flexural resistance.

Cracked Section—A composite section in which the concrete is assumed to carry no tensile stress.

Critical Load—The load at which bifurcation occurs as determined by a theoretical stability analysis.

Cross-Frame—A transverse truss framework connecting adjacent longitudinal flexural components or inside a tub section or closed box used to transfer and distribute vertical and lateral loads and to provide stability to the compression flanges. Sometimes synonymous with the term diaphragm.

Cross-Section Distortion—Change in shape of the cross-section profile due to torsional loading.

Curved Girder—An I-, closed-box, or tub girder that is curved in a horizontal plane.

Deck—A component, with or without wearing surface, that supports wheel loads directly and is supported by other components.

Deck System—A superstructure, in which the deck is integral with its supporting components, or in which the effects of deformation of supporting components on the behavior of the deck is significant.

Deck Truss—A truss system in which the roadway is at or above the level of the top chord of the truss.

Detail Category—A grouping of components and details having essentially the same fatigue resistance.

Diaphragm—A vertically oriented solid transverse member connecting adjacent longitudinal flexural components or inside a closed-box or tub section to transfer and distribute vertical and lateral loads and to provide stability to the compression flanges.

Discretely Braced Flange—A flange supported at discrete intervals by bracing sufficient to restrain lateral deflection of the flange and twisting of the entire cross-section at the brace points.

Distortion-Induced Fatigue—Fatigue effects due to secondary stresses not normally quantified in the typical analysis and design of a bridge.

Edge Distance of Bolts—The distance perpendicular to the line of force between the center of a hole and the edge of the component.

Effective Length—The equivalent length KL used in compression formulas and determined by a bifurcation analysis.

Effective Length Factor—The ratio between the effective length and the unbraced length of the member measured between the centers of gravity of the bracing members.

Effective Net Area—Net area modified to account for the effect of shear lag.

Effective Width—The reduced width of a plate or concrete slab which, with an assumed uniform stress distribution, produces the same effect on the behavior of a structural member as the actual plate width with its nonuniform stress distribution.

Elastic—A structural response in which stress is directly proportional to strain and no deformation remains upon removal of loading.

Elastic Analysis—Determination of load effects on members and connections based on the assumption that the material stress-strain response is linear and the material deformation disappears on removal of the force that produced it.

Elastic-Perfectly Plastic (Elastic-Plastic)—An idealized material stress-strain curve that varies linearly from the point of zero strain and zero stress up to the yield point of the material, and then increases in strain at the value of the yield stress without any further increases in stress.

End Distance of Bolts—The distance along the line of force between the center of a hole and the end of the component.

End Panel—The end section of a truss or girder.

Engineer—A licensed structural engineer responsible for the design of the bridge or review of the bridge construction.

Eyebar—A tension member with a rectangular section and enlarged ends for a pin connection.

Factored Load—The product of the nominal load and a load factor.

Fastener—Generic term for welds, bolts, rivets, or other connecting device.

Fatigue—The initiation and/or propagation of cracks due to a repeated variation of normal stress with a tensile component.

Fatigue Design Life—The number of years that a detail is expected to resist the assumed traffic loads without fatigue cracking. In the development of these Specifications it has been taken as 75 years.

Fatigue Life—The number of repeated stress cycles that results in fatigue failure of a detail.

Fatigue Resistance—The maximum stress range that can be sustained without failure of the detail for a specified number of cycles.

Finite Fatigue Life—The number of cycles to failure of a detail when the maximum probable stress range exceeds the constant amplitude fatigue threshold.

First-Order Analysis—Analysis in which equilibrium conditions are formulated on the undeformed structure; that is, the effect of deflections is not considered in writing equations of equilibrium.

Flange Lateral Bending—Bending of a flange about an axis perpendicular to the flange plate due to lateral loads applied to the flange and/or nonuniform torsion in the member.

Flexural Buckling—A buckling mode in which a compression member deflects laterally without twist or change in cross-sectional shape.

Flexural-Torsional Buckling—A buckling mode in which a compression member bends and twists simultaneously without a change in cross-sectional shape.

Force—Resultant of distribution of stress over a prescribed area. Generic term signifying axial loads, bending moment, torques, and shears.

Fracture-Critical Member (FCM)—Component in tension whose failure is expected to result in the collapse of the bridge or the inability of the bridge to perform its function.

Fracture Toughness—A measure of the ability of a structural material or element to absorb energy without fracture. It is generally determined by the Charpy V-notch test.

Gage of Bolts—The distance between adjacent lines of bolts; the distance from the back of an angle or other shape to the first line of bolts.

Girder—A structural component whose primary function is to resist loads in flexure and shear. Generally, this term is used for fabricated sections.

Grip—Distance between the nut and the bolt head.

Gusset Plate—Plate material used to interconnect vertical, diagonal, and horizontal truss members at a panel point.

Half Through-Truss Spans—A truss system with the roadway located somewhere between the top and bottom chords. It precludes the use of a top lateral system.

HSS—A square, rectangular, or hollow structural steel section produced in accordance with a pipe or tubing product specification.

Hybrid Section—A fabricated steel section with a web that has a specified minimum yield strength lower than one or both flanges.

Inelastic Action—A condition in which deformation is not fully recovered upon removal of the load that produced it.

Inelastic Redistribution—The redistribution of internal force effects in a component or structure caused by inelastic deformations at one or more sections.

Instability—A condition reached in the loading of a component or structure in which continued deformation results in a decrease of load-resisting capacity.

Interior Panel—The interior section of a truss or girder component.

Joint—Area where two or more ends, surfaces, or edges are attached. Categorized by type of fastener used and method of force transfer.

Lacing—Plates or bars to connect components of a member.

Lateral Bending Stress—The normal stress caused by flange lateral bending.

Lateral Bracing—A truss placed in a horizontal plane between two I-girders or two flanges of a tub girder to maintain cross-sectional geometry, and provide additional stiffness and stability to the bridge system.

Lateral Bracing Component—A component utilized individually or as part of a lateral bracing system to prevent buckling of components and/or to resist lateral loads.

Lateral-Torsional Buckling—Buckling of a component involving lateral deflection and twist.

Level—That portion of a rigid frame that includes one horizontal member and all columns between that member and the base of the frame or the next lower horizontal member.

Limit State—A condition in which a component or structure becomes unfit for service and is judged either to be no longer useful for its intended function or to be unsafe. Limits of structural usefulness include brittle fracture, plastic collapse, excessive deformation, durability, fatigue, instability, and serviceability.

Load Effect—Moment, shear, axial force or torque induced in a member by loads applied to the structure.

Load Path—A succession of components and joints through which a load is transmitted from its origin to its destination.

Load-Induced Fatigue—Fatigue effects due to the in-plane stresses for which components and details are explicitly designed.

Local Buckling—The buckling of a plate element in compression.

Longitudinally Loaded Weld—Weld with applied stress parallel to the longitudinal axis of the weld.

Major Axis—The centroidal axis about which the moment of inertia is a maximum; also referred to as the major principal axis.

Net Tensile Stress—The algebraic sum of two or more stresses in which the total is tension.

Noncompact Flange—For a composite section in negative flexure or a noncomposite section, a discretely braced compression flange with a slenderness at or below the limit at which localized yielding within the member cross-section associated with a hybrid web, residual stresses and/or cross-section monosymmetry has a statistically significant effect on the nominal flexural resistance.

Noncompact Section—A composite section in positive flexure for which the nominal resistance is not permitted to exceed the moment at first yield.

Noncompact Unbraced Length—For a composite section in negative flexure or a noncomposite section, the limiting unbraced length of a discretely braced compression flange at or below the limit at which the onset of yielding in either flange of the cross-section with consideration of compression-flange residual stress effects has a statistically significant effect on the nominal flexural resistance.

Noncompact Web—For a composite section in negative flexure or a noncomposite section, a web satisfying steel grade requirements and with a slenderness at or below the limit at which theoretical elastic web bend-buckling does not occur for elastic stress values, computed according to beam theory, smaller than the limit of the nominal flexural resistance.

Noncomposite Section—A steel beam where the deck is not connected to the steel section by shear connectors.

Noncontrolling Flange—The flange at a point of splice opposite the controlling flange.

Nonslender Element Section—Cross-section of a compression member composed of plate components of sufficient slenderness such that they are able to develop their full nominal yield strength prior to the onset of local buckling.

Nonuniform Torsion—An internal resisting torsion in thin-walled sections, also known as warping torsion, producing shear stress and normal stresses, and under which cross-sections do not remain plane. Members developing nonuniform torsion resist the externally applied torsion by warping torsion and St. Venant torsion. Each of these components of internal resisting torsion varies along the member length, although the externally applied concentrated torsion may be uniform along the member between two adjacent points of torsional restraint. Warping torsion is dominant over St. Venant torsion in members having open cross-sections, whereas St. Venant torsion is dominant over warping torsion in members having closed cross-sections.

Open Section—A flexural member having a cross-section which has no enclosed cell. An open-section member resists torsion primarily by nonuniform torsion, which causes normal stresses at the flange tips.

Orthotropic Deck—A deck made of a steel plate stiffened with open or closed steel ribs welded to the underside of a steel plate.

Permanent Deflection—A type of inelastic action in which a deflection remains in a component or system after the load is removed.

Pier—A column or connected group of columns or other configuration designed to be an interior support for a bridge superstructure.

Pitch—The distance between the centers of adjacent bolt holes or shear connectors along the line of force.

Plastic Analysis—Determination of load effects on members and connections based on the assumption of rigid-plastic behavior; i.e., that equilibrium is satisfied throughout the structure and yield is not exceeded anywhere. Second-order effects may need to be considered.

Plastic Hinge—A yielded zone which forms in a structural member when the plastic moment is attained. The beam is assumed to rotate as if hinged, except that the plastic moment capacity is maintained within the hinge.

Plastic Moment—The resisting moment of a fully-yielded cross-section.

Plastic Strain—The difference between total strain and elastic strain.

Plastification—The process of successive yielding of fibers in the cross-section of a member as bending moment is increased.

Plate—A flat rolled product whose thickness exceeds 0.25 in.

Portal Frames—End transverse truss bracing or Vierendeel bracing to provide for stability and to resist wind or seismic loads.

Post-Buckling Resistance—The load that can be carried by a member or component after buckling.

Primary Member—A member designed to carry the internal forces determined from an analysis.

Prying Action—Lever action that exists in connections in which the line of application of the applied load is eccentric to the axis of the bolt, causing deformation of the fitting and an amplification of the axial force in the bolt.

Redistribution Moment—An internal moment caused by yielding in a continuous span bending component and held in equilibrium by external reactions.

Redistribution of Moments—A process that results from formation of inelastic deformations in continuous structures.

Redistribution Stress—The bending stress resulting from the redistribution moment.

Redundancy—The quality of a bridge that enables it to perform its design function in a damaged state.

Redundant Member—A member whose failure does not cause failure of the bridge.

Required Fatigue Life—A product of the single-lane average daily truck traffic, the number of cycles per truck passage, and the design life in days.

Residual Stress—The stresses that remain in an unloaded member or component after it has been formed into a finished product by cold bending, and/or cooling after rolling or welding.

Reverse Curvature Bending—A bending condition in which end moments on a member cause the member to assume an S shape.

Rigid Frame—A structure in which connections maintain the angular relationship between beam and column members under load.

St. Venant Torsion—That portion of the internal resisting torsion in a member producing only pure shear stresses on a cross-section, also referred to as pure torsion or uniform torsion.

Second-Order Analysis—Analysis in which equilibrium conditions are formulated on the deformed structure; that is, in which the deflected position of the structure is used in writing the equations of equilibrium.

Secondary Member—A member in which stress is not normally evaluated in the analysis.

Service Loads—Loads expected to be supported by the structure under normal usage.

Shape Factor—The ratio of the plastic moment to the yield moment, or the ratio of the plastic section modulus to the elastic section modulus.

Shear-Buckling Resistance—The maximum load that can be supported by a web plate without experiencing theoretical buckling due to shear.

Shear Connector—A mechanical device that prevents relative movements both normal and parallel to an interface.

Shear Flow—Shear force per unit width acting parallel to the edge of a plate element.

Shear Lag—Nonlinear distribution of normal stress across a component due to shear distortions.

Sheet—A flat rolled product whose thickness is between 0.006 and 0.25 in.

Single Curvature Bending—A deformed shape of a member in which the center of curvature is on the same side of the member throughout the unbraced length.

Skew Angle—The angle between the axis of support relative to a line normal to the longitudinal axis of the bridge, i.e. a zero-degree skew denotes a rectangular bridge.

Slab—A deck composed of concrete and reinforcement.

Slender Element Section—Cross-section of a compression member composed of plate components of sufficient slenderness such that local buckling in the elastic range will occur.

Slender Flange—For a composite section in negative flexure or a noncomposite section, a discretely braced compression flange with a slenderness at or above which the nominal flexural resistance is governed by elastic flange local buckling, provided that sufficient lateral bracing requirements are satisfied.

Slender Unbraced Length—For a composite section in negative flexure or a noncomposite section, the limiting unbraced length of a discretely braced compression flange at or above which the nominal flexural resistance is governed by elastic lateral torsional buckling.

Slender Web—For a composite section in negative flexure or a noncomposite section, a web with a slenderness at or above which the theoretical elastic bend-buckling stress in flexure is reached in the web prior to reaching the yield strength of the compression flange.

Slenderness Ratio—The ratio of the effective length of a member to the radius of gyration of the member cross-section, both with respect to the same axis of bending, or the full or partial width or depth of a component divided by its thickness.

Splice—A group of bolted connections, or a welded connection, sufficient to transfer the moment, shear, axial force, or torque between two structural elements joined at their ends to form a single, longer element.

Stay-in-Place Formwork—Permanent metal or precast concrete forms that remain in place after construction is finished.

Stiffened Element—A flat compression element with adjoining out-of-plane elements along both edges parallel to the direction of loading.

Stiffener—A member, usually an angle or plate, attached to a plate or web of a beam or girder to distribute load, to transfer shear, or to prevent buckling of the member to which it is attached.

Stiffness—The resistance to deformation of a member or structure measured by the ratio of the applied force to the corresponding displacement.

Strain Hardening—Phenomenon wherein ductile steel, after undergoing considerable deformation at or just above the yield point, exhibits the capacity to resist substantially higher loading than that which caused initial yielding.

Strain-Hardening Strain—For structural steels that have a flat or nearly flat plastic region in the stress-strain relationship, the value of the strain at the onset of strain hardening.

Stress Range—The algebraic difference between extreme stresses resulting from the passage of a load.

Strong-Axis—The centroidal axis about which the moment of inertia is a maximum.

Subpanel—A stiffened web panel divided by one or more longitudinal stiffeners.

Sway Bracing—Transverse vertical bracing between truss members.

Tensile Strength—The maximum tensile stress that a material is capable of sustaining.

Tension-Field Action—The behavior of a girder panel under shear in which diagonal tensile stresses develop in the web and compressive forces develop in the transverse stiffeners in a manner analogous to a Pratt truss.

Through-Girder Spans—A girder system where the roadway is below the top flange.

Through-Thickness Stress—Bending stress in a web or box flange induced by distortion of the cross-section.

Through-Truss Spans—A truss system where the roadway is located near the bottom chord and where a top chord lateral system is provided.

Tie Plates—Plates used to connect components of a member.

Tied Arch—An arch in which the horizontal thrust of the arch rib is resisted by a horizontal tie.

Toe of the Fillet—Termination point of a fillet weld or a rolled section fillet.

Torsional Buckling—A buckling mode in which a compression member twists about its shear center.

Torsional Shear Stress—Shear stress induced by St. Venant torsion.

Transversely Loaded Weld—Weld with applied stress perpendicular to the longitudinal axis of the weld.

Trough-Type Box Section—A U-shaped section without a common top flange.

True Arch—An arch in which the horizontal component of the force in the arch rib is resisted by an external force supplied by its foundation.

Tub Section—An open-topped steel girder which is composed of a bottom flange plate, two inclined or vertical web plates, and an independent top flange attached to the top of each web. The top flanges are connected with lateral bracing members.

Unbraced Length—Distance between brace points resisting the mode of buckling or distortion under consideration; generally, the distance between panel points or brace locations.

Unstiffened Element—A flat compression element with an adjoining out-of-plane element along one edge parallel to the direction of loading.

Von Mises Yield Criterion—A theory which states that the inelastic action at a point under a combination of stresses begins when the strain energy of distortion per unit volume is equal to the strain energy of distortion per unit volume in a simple tensile bar stressed to the elastic limit under a state of uniaxial stress. This theory is also called the maximum strain-energy-of-distortion theory. Accordingly, shear yield occurs at 0.58 times the yield strength.

Warping Stress—Normal stress induced in the cross-section by warping torsion and/or by distortion of the cross-section.

Warping Torsion—That portion of the total resistance to torsion in a member producing shear and normal stresses that is provided by resistance to out-of-plane warping of the cross-section.

Web Crippling—The local failure of a web plate in the immediate vicinity of a concentrated load or bearing reaction due to the transverse compression introduced by this load.

Web Slenderness Ratio—The depth of a web between flanges divided by the web thickness.

Yield Moment—In a member subjected to flexure, the moment at which an outer fiber first attains the yield stress.

Yield Strength—The stress at which a material exhibits a specified limiting deviation from the proportionality of stress to strain.

Yield-Stress Level—The stress determined in a tension test when the strain reaches 0.005 in. per in.

6.3—NOTATION

A	=	detail category constant; area enclosed within centerlines of plates of box members (in. ²); total gross cross-sectional area of the member (in. ²) (6.6.1.2.5) (6.9.4.2.2) (6.12.2.2.2)
A_b	=	projected bearing area on a pin plate (in. ²); cross-sectional area of a bolt (in. ²) (6.8.7.2) (6.13.2.7)
A_{bot}	=	area of the bottom flange (in. ²) (6.10.10.1.2)
A_c	=	area of concrete (in. ²); area of the concrete deck (in. ²) (6.9.5.1) (D6.3.2)
A_d	=	minimum required cross-sectional area of a diagonal member of top lateral bracing for tub sections (in. ²) (C6.7.5.3)
A_{eff}	=	summation of the effective areas of the cross-section based on an effective width for each slender stiffened element in the cross-section = $\sum (b - b_e) t$ (in. ²) (6.9.4.2.2)
$ADTT$	=	average daily truck traffic over the design life (6.6.1.2.5)
$ADTT_{SL}$	=	single-lane $ADTT$ (6.6.1.2.5)
A_e	=	effective net area (in. ²); effective flange area (in. ²) (6.6.1.2.3) (6.13.6.1.4c)
A_f	=	area of the inclined bottom flange (in. ²); area of a box flange including longitudinal flange stiffeners (in. ²); sum of the area of fillers on the top and bottom of a connecting plate (in. ²); area of flange transmitting a concentrated load (in. ²) (C6.10.1.4) (C6.11.11.2) (6.13.6.1.5) (6.13.7.2)
A_{fn}	=	sum of the flange area and the area of any cover plates on the side of the neutral axis corresponding to D_n in a hybrid section (in. ²) (6.10.1.10.1)
A_g	=	gross area of a member (in. ²); gross cross-sectional area of the member (in. ²); gross area of the tension flange (in. ²); gross area of the section based on the design wall thickness (in.) (6.6.1.2.3) (6.8.2.1) (6.9.4.1.1) (6.9.4.1.3) (6.10.1.8) (6.12.1.2.3c) (6.13.6.1.4c)
A_n	=	net cross-section area of a tension member (in. ²); net area of a flange (in. ²) (6.6.1.2.3) (6.8.2.1) (6.10.1.8)
A_o	=	enclosed area within a box section (in. ²) (C6.7.4.3) (6.11.8.2.2)
A_p	=	smaller of either the connected plate area or the sum of the splice plate area on the top and bottom of the connected plate (in. ²) (6.13.6.1.5)
A_{pn}	=	area of the projecting elements of a stiffener outside of the web-to-flange welds but not beyond the edge of the flange (in. ²) (6.10.11.2.3)
A_r	=	area of the longitudinal reinforcement (in. ²) (6.9.5.1)
A_{rb}	=	area of the bottom layer of longitudinal reinforcement within the effective concrete deck width (in. ²) (D6.1)
A_{rs}	=	total area of the longitudinal reinforcement within the effective concrete deck width (in. ²) (D6.3.2)
A_{rt}	=	area of the top layer of longitudinal reinforcement within the effective concrete deck width (in. ²) (D6.1)
A_s	=	area of a structural steel shape (in. ²); total area of longitudinal reinforcement over the interior support within the effective concrete deck width (in. ²); gross area of a splice plate (in. ²); area of the concrete deck (in. ²) (6.10.10.3) (6.13.6.1.4c) (D6.3.2)
A_{sc}	=	cross-sectional area of a stud shear connector (in. ²) (6.10.10.4.3)
A_t	=	area of the tension flange (in. ²) (D6.3.2)
A_{tn}	=	net area along the cut carrying tension stress in block shear (in. ²) (6.13.4)
A_v	=	cross-sectional area of transverse reinforcement that intercepts a diagonal shear crack in a concrete-encased shape (in. ²) (6.12.3.1)
A_{vg}	=	gross area along the cut carrying shear stress in block shear (in. ²); gross area of the connection element subject to shear (in. ²) (6.13.4) (6.13.5.3)
A_{vn}	=	net area along the cut carrying shear stress in block shear (in. ²); net area of the connection element subject to shear (in. ²) (6.13.4) (6.13.5.3)
A_w	=	area of the web of a steel section (in. ²) (6.12.2.3.1)

a	=	distance between connectors (in.); center-to-center distance between flanges of adjacent boxes in a multiple box section (in.); longitudinal spacing of transverse flange stiffeners (in.); distance from the center of a bolt to the edge of a plate subject to a tensile force due to prying action (in.) (6.9.4.3.1) (6.11.2.3) (C6.11.11.2) (6.13.2.10.4)
a_{wc}	=	ratio of two times the web area in compression to the area of the compression flange (6.10.1.10.2)
B	=	outside width of a rectangular Hollow Structural Section (HSS) perpendicular to the plane of the gusset plate(s) (in.) (6.8.2.2)
b	=	width of a rectangular plate element (in.); width of the body of an eyebar (in.); widest flange width (in.); distance from the edge of a plate or the edge of a perforation to the point of support or distance between supports (in.); clear distance between plates (in.); the smaller of d_o and D (in.); width of a rectangular tube (in.); overall thickness of the composite cross-section of a concrete-encased steel shape in the plane of buckling (in.); distance from the center of a bolt to the toe of the fillet of a connected part (in.); distance between the toe of the flange and the centerline of the web (in.) (C6.7.4.3) (6.7.6.3) (6.7.7.2) (6.10.11.1.3) (6.12.2.2.2) (6.12.2.2.5) (6.12.2.3.1) (6.13.2.10.4) (6.14.4.2)
b_1, b_2	=	individual flange widths (in.) (C6.9.4.1.3)
b_c	=	full width of the compression flange (in.) (D6.1)
b_f	=	full width of the flange (in.); for I-sections, full width of the widest flange within the field section under consideration (in.); for tub sections, full width of the widest top flange within the field section under consideration (in.); for closed box sections, the limit of $b_f/4$ does not apply (in.) (C6.7.4.2) (6.10.11.1.2) (6.12.2.2.4) (6.12.2.2.5)
b_{fc}	=	full width of the compression flange; compression-flange width between webs; clear width of the compression flange between the webs less the inside corner radius on each side (in.) (6.10.1.10.2) (6.11.8.2.2) (6.12.2.2.2)
b_{ft}	=	full width of the tension flange (in.); width of a box flange in tension between webs (in.) (C6.10.9.1) (6.11.9)
b_ℓ	=	projecting width of a longitudinal stiffener (in.); length of the longer leg of an unequal-leg angle (in.) (6.9.4.4) (6.10.11.1.3)
b_s	=	effective width of the concrete deck (in.) (6.10.1.10.2)
b_s	=	length of the shorter leg of an unequal-leg angle (in.) (6.9.4.4)
b_t	=	projecting width of a transverse or bearing stiffener (in.); full width of the tension flange (in.) (6.10.11.1.2) (D6.1)
C	=	ratio of the shear-buckling resistance to the shear specified minimum yield strength (6.10.9.2)
C_b	=	moment gradient modifier (6.10.1.6) (6.12.2.2.5) (6.12.2.2.7)
C_w	=	warping torsional constant (in. ⁶) (6.9.4.1.3) (6.12.2.2.5)
C_1, C_2, C_3	=	composite column constants specified in Table 6.9.5.1-1 (6.9.5.1)
c	=	distance from the center of the longitudinal reinforcement to the nearest face of a concrete-encased shape in the plane of bending (in.) (6.12.2.3.1)
c_{rb}	=	distance from the top of the concrete deck to the centerline of the bottom layer of longitudinal concrete deck reinforcement (in.) (D6.1)
c_{rt}	=	distance from the top of the concrete deck to the centerline of the top layer of longitudinal concrete deck reinforcement (in.) (D6.1)
D	=	diameter of a pin (in.); clear distance between flanges (in.); outside diameter of a circular Hollow Structural Section (HSS) (in.); outside diameter of a circular steel tube (in.); outside diameter of tube (in.); web depth (in.); depth of the web plate measured along the slope (in.); clear distance between the flanges less the inside corner radius on each side (in.) (6.7.6.2.1) (6.7.7.2) (6.8.2.2) (6.9.4.2) (6.9.4.2.1) (6.10.1.9.1) (6.11.9) (6.12.1.2.3c) (6.12.2.2.2) (6.12.2.2.3) (6.12.2.2.5)
D'	=	depth at which a composite section reaches its theoretical plastic moment capacity when the maximum strain in the concrete deck is at its theoretical crushing strain (in.) (C6.10.7.3)
D_c	=	depth of the web in compression in the elastic range (in.) (6.10.1.9.1)
$DC1$	=	permanent load acting on the noncomposite section (C6.10.11.3.1)
$DC2$	=	permanent load acting on the long-term composite section (C6.10.11.3.1)
D_{cp}	=	depth of the web in compression at the plastic moment (in.) (6.10.6.2.2)
D_n	=	larger of the distances from the elastic neutral axis of the cross-section to the inside face of either flange in a hybrid section, or the distance from the neutral axis to the inside face of the flange on the side of the neutral axis where yielding occurs first when the neutral axis is at the mid-depth of the web (in.) (6.10.1.10.1)
D_p	=	distance from the top of the concrete deck to the neutral axis of the composite section at the plastic moment (in.) (6.10.7.1.2)
D_t	=	total depth of the composite section (in.) (6.10.7.1.2)
DW	=	wearing surface load (C6.10.11.3.1)

d	=	total depth of the steel section (in.); diameter of a stud shear connector (in.); depth of the member in the plane of flexure (in.); depth of the member in the plane of shear (in.); nominal diameter of a bolt (in.); total depth of the section (in.) depth of the rectangular bar (in.) (C6.10.8.2.3) (6.10.10.2) (6.12.2.2.4) (6.12.2.2.7) (6.12.2.3.1) (6.12.3.1) (6.13.2.4.2)
d_b	=	depth of a beam in a rigid frame (in.) (6.13.7.2)
d_c	=	depth of a column in a rigid frame (in.); distance from the plastic neutral axis to the midthickness of the compression flange used to compute the plastic moment (in.) (6.13.7.2) (D6.1)
d_o	=	transverse stiffener spacing (in.); the smaller of the adjacent web panel widths (in.) (6.10.9.3.2) (6.10.11.1.3)
d_{rb}	=	distance from the plastic neutral axis to the centerline of the bottom layer of longitudinal concrete deck reinforcement used to compute the plastic moment (in.) (D6.1)
d_{rt}	=	distance from the plastic neutral axis to the centerline of the top layer of longitudinal concrete deck reinforcement used to compute the plastic moment (in.) (D6.1)
d_s	=	distance from the centerline of the closest plate longitudinal stiffener or from the gage line of the closest angle longitudinal stiffener to the inner surface or leg of the compression-flange element (in.); distance from the plastic neutral axis to the midthickness of the concrete deck used to compute the plastic moment (in.) (6.10.1.9.2) (D6.1)
d_t	=	distance from the plastic neutral axis to the midthickness of the tension flange used to compute the plastic moment (in.) (D6.1)
d_w	=	distance from the plastic neutral axis to the middepth of the web used to compute the plastic moment (in.) (D6.1)
E	=	modulus of elasticity of steel (ksi) (6.7.7.3)
E_c	=	modulus of elasticity of concrete (ksi) (6.10.1.1.1b)
E_e	=	modified modulus of elasticity of steel for a composite column (ksi) (6.9.5.1)
EXX	=	classification number for weld metal (C6.13.3.2.1)
F_{cf}	=	design stress for the controlling flange at a point of splice (ksi) (C6.13.6.1.4b)
FCM	=	fracture-critical member (6.6.2)
F_{cb}	=	nominal axial compression buckling resistance of the flange (6.11.8.2.2)
F_{cr}	=	critical buckling stress for plates (ksi); elastic lateral torsional buckling stress (ksi); shear buckling resistance (ksi); elastic local buckling stress (ksi) (C6.9.4.2) (6.10.1.6) (6.12.1.2.3c) (6.12.2.2.3) (6.12.2.2.5)
F_{crs}	=	local buckling stress for the stiffener (ksi) (6.10.11.1.3)
F_{crw}	=	nominal web bend-buckling resistance (ksi) (6.10.1.9.1)
F_{cv}	=	nominal shear buckling resistance of the flange (6.11.8.2.2)
F_e	=	nominal compressive resistance of composite members (ksi) (6.9.5.1)
F_{exx}	=	classification strength of weld metal (ksi) (6.13.3.2.2b)
F_{fat}	=	radial fatigue shear range per unit length, taken as the larger of either F_{fat1} or F_{fat2} (kip/in.) (6.10.10.1.2)
F_{fat1}	=	radial fatigue shear range per unit length due to the effect of any curvature between brace points (kip/in.) (6.10.10.1.2)
F_{fat2}	=	radial fatigue shear range per unit length due to torsion caused by effects other than curvature, such as skew (kip/in.) (6.10.10.1.2)
F_ℓ	=	statically equivalent uniformly distributed lateral force due to the factored loads from concrete deck overhang brackets (kip/in.) (C6.10.3.4)
FLB	=	flange local buckling (C6.10.8.2.1) (CA6.3.1) (CD6.4.1) (CD6.4.2)
F_{max}	=	maximum potential compression-flange flexural resistance (ksi) (C6.10.8.2.1)
F_n	=	nominal flexural resistance of a flange (ksi) (C6.10.8.2.1)
F_{nc}	=	nominal flexural resistance of a compression flange (ksi) (C6.8.2.3)
$F_{nc(FLB)}$	=	nominal compression-flange local buckling flexural resistance (ksi) (CD6.4.1)
F_{nt}	=	nominal flexural resistance of a tension flange (ksi) (C6.8.2.3)
F_p	=	total radial force in the concrete deck at the point of maximum positive live load plus impact moment for the design of the shear connectors at the strength limit state, taken equal to zero for straight spans or segments (kip) (6.10.10.4.2)
F_{rc}	=	net range of cross-frame force at the top flange (kip) (6.10.10.1.2)
F_s	=	vertical force on the connection between a longitudinal and a transverse flange stiffener (kip); Service II design stress for the flange under consideration at a point of splice (ksi) (C6.11.11.2) (6.13.6.1.4c)
F_T	=	total radial force in the concrete deck between the point of maximum positive live load plus impact moment and the centerline of an adjacent interior support for the design of shear connectors at the strength limit state, taken equal to zero for straight spans or segments (kip) (6.10.10.4.2)

F_u	=	specified minimum tensile strength of steel (ksi); specified minimum tensile strength of a stud shear connector (ksi); specified minimum tensile strength of a connected part (ksi); tensile strength of the connection element (ksi) (6.4.1) (6.10.10.4.3) (6.13.2.9) (6.13.5.3)
F_{ub}	=	specified minimum tensile strength of a bolt (ksi) (6.13.2.7)
F_{vr}	=	factored torsional shear resistance of a box flange (ksi) (6.11.1.1)
F_w	=	vertical force on the connection between a transverse flange stiffener and a box section web (kip) (C6.11.11.2)
F_y	=	specified minimum yield strength of steel (ksi); specified minimum yield strength of a pin (ksi); specified minimum yield strength of a pin plate (ksi); specified minimum yield strength of a connected part (ksi); specified minimum yield strength of a splice plate (ksi); specified minimum yield strength (ksi) (6.4.1) (6.7.6.2.1) (6.8.7.2) (6.9.4.1.1) (6.12.2.2.4) (6.12.2.2.5) (6.12.2.2.7) (6.13.4) (6.13.6.1.4c)
F_{yc}	=	specified minimum yield strength of a compression flange (ksi) (C6.8.2.3)
F_{yf}	=	specified minimum yield strength of a flange (ksi) (6.7.7.3)
F_{yr}	=	compression-flange stress at the onset of nominal yielding within the cross-section, including residual stress effects but not including compression-flange lateral bending, taken as the smaller of $0.7F_{yc}$ and F_{yw} , but not less than $0.5F_{yc}$; smaller of the compression-flange stress at the onset of nominal yielding, with consideration of residual stress effects, or the specified minimum yield strength of the web (ksi) (6.10.8.2.2) (6.11.8.2.2)
F_{yrb}	=	specified minimum yield strength of the bottom layer of longitudinal concrete deck reinforcement (ksi) (D6.1)
F_{yrs}	=	specified minimum yield strength of the longitudinal concrete deck reinforcement (ksi) (D6.3.2)
F_{yrt}	=	specified minimum yield strength of the top layer of longitudinal concrete deck reinforcement (ksi) (D6.1)
F_{ys}	=	specified minimum yield strength of a stiffener (ksi); specified minimum yield strength of the stiffener (ksi) (6.10.11.1.2) (6.10.11.1.3)
F_{yt}	=	specified minimum yield strength of a tension flange (ksi) (C6.8.2.3)
F_{yw}	=	specified minimum yield strength of a web (ksi) (6.7.7.2)
f	=	axial or interaction stress range in various components of an orthotropic deck (ksi); shear flow in a box section (kip/in.); $Q_s F_y$ (ksi) (6.6.1.2.3) (C6.11.1.1) (6.9.4.2.2)
f_0	=	stress due to the factored loads without consideration of flange lateral bending at a brace point opposite to the one corresponding to f_2 , calculated from the moment envelope value that produces the largest compression at this point in the flange under consideration, or the smallest tension if this point is never in compression; positive for compression and negative for tension (ksi) (6.10.8.2.3)
f_1	=	axial stress range in various components of an orthotropic deck (ksi); stress at the opposite end of an unbraced length from f_2 representing the intercept of the most critical assumed linear stress distribution through either f_2 and f_{mid} , or through f_2 and f_0 , taken as $2f_{mid} - f_2 \geq f_0$ (ksi) (C6.6.1.2.3) (6.10.8.2.3)
f_2	=	local bending stress range in various components of an orthotropic deck caused by rib-floorbeam interaction (ksi); largest compressive stress due to the factored loads without consideration of lateral bending at either end of an unbraced length calculated from the critical moment envelope value; always taken as positive unless stress is zero or tensile at both ends of the unbraced length in which case f_2 is taken as zero (ksi) (C6.6.1.2.3) (6.10.8.2.3)
f_a	=	axial stress due to the factored loads in a solid web arch (ksi) (6.14.4.2)
f_b	=	maximum stress due to factored loadings, including moment amplification, in a solid web arch (ksi) (6.14.4.2)
f_{bu}	=	largest value of the compressive stress throughout the unbraced length in the flange under consideration, calculated without consideration of flange lateral bending (ksi) (6.10.1.6)
f_{by}	=	stress in a box flange at an interior pier due to the factored loads caused by major-axis bending of the internal diaphragm over the bearing sole plate (ksi) (C6.11.8.1.1)
f_c	=	compression-flange stress due to the Service II loads calculated without consideration of flange lateral bending (ksi); sum of the various compression-flange flexural stresses caused by the different loads, i.e., $DC1$, $DC2$, DW and $LL+IM$, acting on their respective sections (ksi); compression-flange stress at the section under consideration (6.10.4.2.2) (6.12.2.2.2) (D6.3.1)
f'_c	=	minimum specified 28-day compressive strength of concrete (ksi) (6.9.5.1) (6.10.4.2.1)
f_{cf}	=	maximum flexural stress due to the factored loads at the midthickness of the controlling flange at a point of splice (ksi) (6.13.6.1.4c)
f_d	=	shear stress in a box flange at an interior pier caused by the internal diaphragm vertical shear due to the factored loads (ksi) (C6.11.8.1.1)
f_{DC1}	=	compression-flange stress caused by the factored permanent load applied before the concrete deck has hardened or is made composite, calculated without consideration of flange lateral bending (ksi) (6.10.1.10.2)

f_{DC2}	=	compression-flange stress caused by the factored permanent load acting on the long-term composite section, calculated without consideration of flange lateral bending (ksi) (C6.10.11.3.1)
f_f	=	flange stress due to the Service II loads calculated without consideration of flange lateral bending (ksi) (6.10.4.2.2)
f_ℓ	=	flange lateral bending stress (ksi); second-order compression-flange lateral bending stress (ksi); flange lateral bending stress due to the Service II loads (ksi); lateral bending stress in the flange under consideration at an interior-pier section (ksi) (6.10.1.6) (6.10.4.2.2) (B6.4.2.1)
$f_{\ell 1}$	=	first-order compression-flange lateral bending stress at a section, or the maximum first-order lateral bending stress in the compression flange throughout the unbraced length, as applicable (ksi) (6.10.1.6)
f_{LL+IM}	=	compression-flange stress caused by the factored vehicular live load plus impact acting on the short-term composite section, calculated without consideration of flange lateral bending (ksi) (C6.10.11.3.1)
f_{mid}	=	stress due to the factored loads without consideration of flange lateral bending at the middle of the unbraced length of the flange under consideration, calculated from the moment envelope value that produces the largest compression at this point, or the smallest tension if this point is never in compression; positive for compression and negative for tension (ksi) (6.10.8.2.3)
f_n	=	normal stress in the inclined bottom flange of a variable web depth member (ksi); largest of the specified minimum yield strengths of each component included in the calculation of A_{fn} for a hybrid section when yielding occurs first in one of the components, or the largest of the elastic stresses in each component on the side of the neutral axis corresponding to D_n at first yield on the opposite side of the neutral axis (ksi) (C6.10.1.4) (6.10.1.10.1)
f_{ncf}	=	flexural stress due to the factored loads at the midthickness of the noncontrolling flange at a point of splice concurrent with f_{cf} (ksi) (C6.13.6.1.4b)
f_{os}	=	flexural stress due to the Service II loads at the midthickness of the other flange at a point of splice concurrent with f_s in the flange under consideration (ksi) (C6.13.6.1.4b)
f_r	=	modulus of rupture of concrete (ksi) (6.10.1.7) (6.10.4.2.1)
f_s	=	flexural stress due to the factored loads in a longitudinal web stiffener (ksi); largest of the longitudinal stresses due to the factored loads in the panels of a box flange on either side of a transverse flange stiffener (ksi); maximum flexural stress due to the Service II loads at the midthickness of the flange under consideration at a point of splice (ksi) (6.10.11.3.1) (C6.11.11.2) (C6.13.6.1.4b)
f_{sr}	=	bending stress range in the longitudinal reinforcement over an interior pier (ksi) (6.10.10.3)
f_t	=	stress due to the factored loads on the gross area of a tension flange calculated without consideration of flange lateral bending (ksi); sum of the various tension-flange flexural stresses caused by the different loads, i.e., $DC1$, $DC2$, DW , and $LL+IM$, acting on their respective sections (ksi) (6.10.1.8) (D6.3.1)
f_v	=	St. Venant torsional shear stress in a box flange due to the factored loads; St. Venant torsional shear stress in the flange due to the factored loads at the section under consideration (ksi) (6.11.3.2) (6.11.8.2.2)
f_{xx}	=	various compression-flange flexural stresses caused by the different factored loads, i.e., $DC1$, $DC2$, DW , and $LL+IM$, acting on their respective sections (ksi) (C6.10.11.3.1)
G	=	shear modulus of steel (ksi); shear modulus of elasticity for steel = $0.385E$ (ksi) (6.9.4.1.3) (C6.12.2.2.2) (6.12.2.2.4)
g	=	distance between lines of bolts (in.); horizontal pitch of bolts in a web splice (in.) (6.8.3) (C6.13.6.1.4b)
H	=	effective throat of a fillet weld (in.); outside width of a rectangular Hollow Structural Section (HSS) parallel to the plane of an end gusset plate(s) (in.) (6.6.1.2.5) (6.8.2.2)
H_{uw}	=	design horizontal force resultant at the middepth of the web at a point of splice (kip) (C6.13.6.1.4b)
h	=	distance between centroids of individual component shapes perpendicular to the member axis of buckling (in.); depth between the centerline of the flanges (in.); distance between flange centroids (in.) (6.9.4.3.1) (C6.9.4.1.3) (C6.10.8.2.3)
h_o	=	distance between flange centroids (in.) (6.12.2.2.5)
I	=	moment of inertia of the short-term composite section, or optionally in regions of negative flexure of straight girders only, the moment of inertia of the steel section plus the longitudinal reinforcement if the concrete is not considered to be effective in tension in computing the range of longitudinal stress (in. ⁴); moment of inertia of the effective internal interior-pier diaphragm within a box section (in. ⁴) (6.10.10.1.2) (C6.11.8.1.1)
I_ℓ	=	moment of inertia of a longitudinal web stiffener including an effective width of web taken about the neutral axis of the combined section (in. ⁴); required moment of inertia of a longitudinal flange stiffener taken about an axis parallel to a box flange and taken at the base of the stiffener (in. ⁴) (6.10.11.1.3) (6.11.11.2)
I_p	=	polar moment of inertia of a web-splice bolt group (in. ²) (C6.13.6.1.4b)

I_s	=	actual moment of inertia of a longitudinal flange stiffener taken about an axis parallel to a box flange and taken at the base of the stiffener (in. ⁴); moment of inertia of an arch rib stiffener (in. ⁴) (6.11.8.2.3) (6.14.4.2)
I_t	=	moment of inertia of the transverse web stiffener taken about the edge in contact with the web for single stiffeners and about the mid-thickness of the web for stiffener pairs (in. ⁴); moment of inertia of a transverse flange stiffener taken about an axis through its centroid and parallel to its bottom edge (in. ⁴) (6.10.11.1.3) (C6.11.11.2)
I_x	=	moments of inertia about the major principal axis of the cross-section (in. ⁴) (6.9.4.1.3)
I_y	=	moment of inertia of a box-shaped member about an axis perpendicular to the axis of bending (in. ⁴); moments of inertia about the minor principal axis of the cross-section (in. ⁴) moment of inertia about the y -axis (in. ⁴) (6.9.4.1.3) (6.12.2.2.2) (6.12.2.2.4) (6.12.2.2.5)
I_{yc}	=	moment of inertia of the compression flange of a steel section about the vertical axis in the plane of the web (in. ⁴) (6.10.2.2)
I_{yt}	=	moment of inertia of the tension flange of a steel section about the vertical axis in the plane of the web (in. ⁴) (6.10.2.2)
IM	=	dynamic load allowance from Article 3.6.2
J	=	St. Venant torsional constant (in. ⁴); stiffener bending rigidity parameter (C6.7.4.3) (6.9.4.1.3) (6.10.11.1.3) (6.12.2.2.4) (6.12.2.2.5)
K	=	effective length factor; effective length factor in the plane of buckling determined as specified in Article 4.6.2.5 (6.9.3) (6.9.4.1.2)
K_h	=	hole size factor for bolted connections (6.13.2.8)
K_s	=	surface condition factor for bolted connections (6.13.2.8)
$K_x \ell_x$	=	effective length for flexural buckling about the x -axis (in.) (6.9.4.1.3)
$K_y \ell_y$	=	effective length for flexural buckling about the y -axis (in.) (6.9.4.1.3)
$K_z \ell_z$	=	effective length for torsional buckling (in.) (6.9.4.1.3)
$K\ell/r$	=	slenderness ratio (6.9.3)
k	=	plate buckling coefficient specified in Table 6.9.4.2.1-1; elastic web bend-buckling coefficient; shear-buckling coefficient for webs; plate-buckling coefficient for uniform normal stress in box flanges; distance from the outer face of the flange to the toe of a web fillet of a rigid frame member to be stiffened (in.); plate-buckling coefficient for uniform normal stress; distance from the outer face of a flange resisting a concentrated load or a bearing reaction to the web toe of the fillet (in.) (6.9.4.2.1) (6.9.4.3.2) (6.10.1.9.1) (6.10.9.3.2) (6.11.8.2.2) (6.13.7.2) (6.14.4.2) (D6.5.2)
k_c	=	flange local buckling coefficient (6.9.4.2.1)
k_s	=	plate-buckling coefficient for shear stress (6.11.8.2.2)
k_{sf}	=	elastic web bend-buckling coefficient for fully restrained longitudinal edge conditions (C6.10.1.9.1)
k_{ss}	=	elastic web bend-buckling coefficient for simply-supported longitudinal edge conditions (C6.10.1.9.1)
L	=	effective span length for determining additional camber to compensate for possible loss of camber in a heat-curved girder (in.); maximum length of the connection longitudinal welds or the out-to-out distance between the bolts in the connection parallel to the line of force (in.); length of a girder shipping piece (in.); distance from a single bolt to the free edge of the member measured parallel to the line of applied force (in.) (6.6.1.2.3) (6.7.7.3) (6.8.2.2) (C6.10.3.4) (C6.13.2.9)
L_b	=	unbraced length (in.); unbraced length for lateral displacement or twist, as applicable (in.) (6.7.4.2) (6.12.2.2.4) (6.12.2.2.5) (6.12.2.2.7)
L_c	=	length of a channel shear connector (in.); clear distance between bolt holes or between the bolt hole and the end of the member in the direction of the applied bearing force (in.) (6.10.10.4.3) (6.13.2.9)
L_{cp}	=	length of a cover plate (ft) (6.10.12.1)
LFD	=	load factor design
LL	=	vehicular live load
L_n	=	arc length between the point of maximum positive live load plus impact moment and the centerline of an adjacent interior support (ft) (6.10.10.4.2)
L_p	=	limiting unbraced length to achieve the nominal flexural resistance of $R_b R_h F_{yc}$ under uniform bending (in.); arc length between an end of the girder and an adjacent point of maximum positive live load plus impact moment (ft); limiting unbraced length to achieve the nominal flexural resistance M_p under uniform bending (in.) (6.10.1.6) (6.10.10.4.2) (6.12.2.2.5)
L_r	=	limiting unbraced length to achieve the onset of nominal yielding in either flange under uniform bending with consideration of compression-flange residual stress effects (in.) (6.7.4.2) (6.12.2.2.5)
$LRFD$	=	load and resistance factor design

LTB	= lateral torsional buckling (C6.10.8.2.1) (C6.10.8.2.3) (CA6.3.1) (CA6.3.3) (CD6.4.1) (CD6.4.2)
L_v	= distance between points of maximum and zero shear (in.) (6.12.1.2.3c)
ℓ	= unbraced member length (in.); distance between the work points of the joints measured along the length of the angle (in.); unbraced length in the plane of buckling (in.) (6.8.4) (6.9.4.1.2) (6.9.4.4)
M	= bending moment about the major-axis of the cross-section (k-in.) (C6.10.1.4)
M_0	= bending moment due to the factored loads at a brace point opposite to the one corresponding to M_2 , calculated from the moment envelope value that produces the largest compression at this point in the flange under consideration, or the smallest tension if this point is never in compression; positive when it causes compression and negative when it causes tension in the flange under consideration (k-in.) (A6.3.3)
M_1	= bending moment at the opposite end of an unbraced length from M_2 representing the intercept of the most critical assumed linear stress distribution through either M_2 and M_{mid} , or through M_2 and M_0 , taken as $2M_{mid} - M_2 \geq M_0$ (k-in.); bending moment about the major-axis of the cross-section at the brace point with the lower moment due to the factored loads adjacent to an interior-pier section from which moments are redistributed taken as either the maximum or minimum moment envelope value, whichever produces the smallest permissible unbraced length (k-in.) (A6.3.3) (B6.2.4)
M_2	= largest major-axis bending moment due to the factored loads at either end of an unbraced length causing compression in the flange under consideration, calculated from the critical moment envelope value; always taken as positive unless the moment is zero or causes tension in the flange under consideration at both ends of the unbraced length in which case M_2 is taken as zero (k-in.); bending moment about the major-axis of the cross-section at the brace point with the higher moment due to the factored loads adjacent to an interior-pier section from which moments are redistributed taken as the critical moment envelope value (k-in.) (A6.3.3) (B6.2.4)
M_{AD}	= additional bending moment that must be applied to the short-term composite section to cause nominal yielding in either steel flange (k-in.) (D6.2.2)
M_c	= column moment due to the factored loading in a rigid frame (k-in.) (6.13.7.2)
M_{cr}	= elastic lateral-torsional buckling moment (k-in.) (C6.12.2.2.2)
M_{D1}	= bending moment caused by the factored permanent load applied before the concrete deck has hardened or is made composite (k-in.) (D6.2.2)
M_{D2}	= bending moment caused by the factored permanent load applied to the long-term composite section (k-in.) (D6.2.2)
M_e	= critical elastic moment envelope value due to the factored loads at an interior-pier section from which moments are redistributed (k-in.) (B6.3.3.1)
M_{fb}	= applied moment due to the factored loads in a transverse beam supporting an orthotropic deck (k-in.) (6.14.3.4)
M_{ft}	= applied transverse moment due to the factored loads in an orthotropic deck plate as a result of the plate carrying wheel loads to adjacent longitudinal ribs (k-in.) (6.14.3.4)
M_ℓ	= lateral bending moment in the flanges due to the eccentric loadings from concrete deck overhang brackets (k-in.) (C6.10.3.4)
M_{max}	= maximum potential flexural resistance based on the compression flange (k-in.) (C6.10.8.2.1)
M_{mid}	= major-axis bending moment due to the factored loads at the middle of an unbraced length, calculated from the moment envelope value that produces the largest compression at this point in the flange under consideration, or the smallest tension if this point is never in compression; positive when it causes compression and negative when it causes tension in the flange under consideration (k-in.) (A6.3.3)
M_n	= nominal flexural resistance of a section (k-in.) (6.10.7.1.1)
M_{nc}	= nominal flexural resistance based on the compression flange (k-in.) (C6.8.2.3)
$M_{nc(FLB)}$	= nominal flexural resistance based on compression flange local buckling (k-in.) (CD6.4.2)
M_{nt}	= nominal flexural resistance based on the tension flange (k-in.) (C6.8.2.3)
M_p	= plastic moment (k-in.) (6.10.7.1.2) (6.12.2.2.2) (6.12.2.2.3) (6.12.2.2.4) (6.12.2.2.5) (6.12.2.2.7)
M_{pe}	= negative-flexure effective plastic moment at interior-pier sections from which moments are redistributed (k-in.) (B6.3.3.1)
M_{ps}	= plastic moment resistance of the steel section of a concrete-encased member (k-in.) (6.12.2.3.1)
M_r	= factored flexural resistance (k-in.) (6.12.1.2.1)
M_{rb}	= factored flexural resistance of a transverse beam supporting an orthotropic deck (k-in.) (6.14.3.4)
M_{rd}	= redistribution moment (k-in.) (B6.3.3.1)
M_{rt}	= factored flexural resistance of an orthotropic deck plate in carrying wheel loads to adjacent ribs (k-in.) (6.14.3.4)

M_{rx}	=	factored flexural resistance about the x -axis taken equal to ϕ_f times the nominal flexural resistance about the x -axis determined as specified in Article 6.10, 6.11 or 6.12, as applicable (kip-in.) (6.9.4.2.1)
M_{ry}	=	factored flexural resistance about the y -axis taken equal to ϕ_f times the nominal flexural resistance about the y -axis determined as specified in Article 6.12, as applicable (kip-in.) (6.9.4.2.1)
M_{rx}, M_{ry}	=	factored flexural resistance about the x - and y -axes, respectively (k-in.) (6.8.2.3)
M_u	=	moment due to the factored loads (k-in.); largest value of the major-axis bending moment throughout the unbraced length causing compression in the flange under consideration (k-in.) (6.7.6.2.1) (6.10.1.6)
M_{tw}	=	design moment at the middepth of the web at a point of splice (k-in.) (C6.13.6.1.4b)
M_{ux}, M_{uy}	=	flexural moments due to the factored loads about the x - and y -axes, respectively (k-in.) (6.8.2.3)
M_{ix}	=	flexural moment about the x -axis resulting from factored loads (kip-in.) (6.9.4.2.1)
M_{iy}	=	flexural moment about the y -axis resulting from factored loads (kip-in.) (6.9.4.2.1)
M_y	=	yield moment (k-in.); yield moment based on the distance to the tip of the stem (kip-in.) (6.10.7.1.2) (6.12.2.2.4) (6.12.2.2.7)
M_{yc}	=	yield moment with respect to the compression flange (k-in.); yield moment of the composite section of a concrete-encased shape (k-in.) (C6.8.2.3) (6.12.2.3.1)
M_{yt}	=	yield moment with respect to the tension flange (k-in.) (C6.8.2.3)
m	=	number of vertical rows of bolts in a web splice (C6.13.6.1.4b)
N	=	number of cycles of stress range; length of bearing, taken greater than or equal to k at end bearing locations (in.) (6.6.1.2.5) (D6.5.2)
NDT	=	nondestructive testing
N_s	=	number of shear planes per bolt; number of slip planes per bolt (6.13.2.7) (6.13.2.8)
n	=	number of cycles per truck passage; modular ratio; number of shear connectors in a cross-section; minimum number of shear connectors over the region under consideration; number of equally spaced longitudinal flange stiffeners; number of bolts in one vertical row of a web splice (6.6.1.2.5) (6.9.5.1) (6.10.10.1.2) (6.10.10.4.1) (6.11.8.2.3) (C6.13.6.1.4b)
n_{ac}	=	number of additional shear connectors required in the regions of points of permanent load contraflexure for sections that are noncomposite in negative-flexure regions (6.10.10.3)
P	=	total nominal shear force in the concrete deck for the design of the shear connectors at the strength limit state (kip) (6.10.10.4.1)
P_{1n}	=	longitudinal force in the girder over an interior support for the design of the shear connectors at the strength limit state (kip) (6.10.10.4.2)
P_{1p}	=	longitudinal force in the concrete deck at the point of maximum positive live load plus impact moment for the design of the shear connectors at the strength limit state (kip) (6.10.10.4.2)
P_{2n}	=	longitudinal force in the concrete deck over an interior support for the design of the shear connectors at the strength limit state (kip) (6.10.10.4.2)
P_{2p}	=	longitudinal force in the girder at the point of maximum positive live load plus impact moment for the design of the shear connectors at the strength limit state (kip) (6.10.10.4.2)
P_c	=	plastic force in the compression flange used to compute the plastic moment (kip) (D6.1)
P_e	=	elastic critical buckling resistance determined as specified in Article 6.9.4.1.2 for flexural buckling, and as specified in Article 6.9.4.1.3 for torsional buckling or flexural-torsional buckling, as applicable (kips) (6.9.4.1.1)
P_h	=	horizontal component of the flange force in the inclined bottom flange of a variable web depth member (kip) (C6.10.1.4)
P_ℓ	=	statically equivalent concentrated lateral concrete deck overhang bracket force placed at the middle of the unbraced length (kip) (C6.10.3.4)
P_n	=	nominal bearing resistance on pin plates (kip); nominal axial compressive resistance (kip); total longitudinal force in the concrete deck over an interior support for the design of the shear connectors at the strength limit state, taken as the lesser of either P_{1n} or P_{2n} (kip) (6.8.7.2) (6.9.2.1) (6.10.10.4.2)
P_{ny}	=	nominal axial tensile resistance for yielding in the gross section (kip) (6.8.2.1)
P_o	=	equivalent nominal yield resistance = $QF_y A_g$ (kips) (6.9.4.1.1)
P_p	=	total longitudinal force in the concrete deck at the point of maximum positive live load plus impact moment for the design of the shear connectors at the strength limit state, taken as the lesser of either P_{1p} or P_{2p} (kip) (6.10.10.4.2)

- P_r = factored axial tensile or compressive resistance (kip); factored bearing resistance on pin plates (kip); factored axial resistance of bearing stiffeners (kip); nominal flexural resistance of an orthotropic deck, with consideration of the effective width of the deck (kip); factored axial compressive resistance of a steel pile (kip); factored compressive resistance determined as specified in Article 6.9.2.1 (kip) (6.8.2.1) (6.8.7.2) (6.9.2.2) (6.9.4.2.1) (6.9.4.3.2) (6.10.11.2.4a) (6.15.3.1)
- P_{rb} = plastic force in the bottom layer of longitudinal deck reinforcement used to compute the plastic moment (kip) (D6.1)
- P_{rt} = plastic force in the top layer of longitudinal deck reinforcement used to compute the plastic moment (kip) (D6.1)
- P_s = plastic compressive force in the concrete deck used to compute the plastic moment (kip) (D6.1)
- P_T = total longitudinal force in the concrete deck between the point of maximum positive live load plus impact moment and the centerline of an adjacent interior support for the design of the shear connectors at the strength limit state, taken as the sum of P_p and P_n (kip) (6.10.10.4.2)
- P_t = minimum required bolt tension (kip); plastic force in the tension flange used to compute the plastic moment (kip) (6.13.2.8) (D6.1)
- P_u = applied axial force due to the factored loads (kip); direct tension or shear force on a bolt due to the factored loads (kip); global tension due to the factored loads on an orthotropic deck (kip); axial compressive force effect resulting from factored loads (kip) (6.8.2.3) (6.9.4.2.1) (6.13.2.10.4) (6.13.2.11)
- P_v = vertical component of the flange force in the inclined bottom flange of a variable web depth member (kip) (C6.10.1.4)
- P_w = plastic force in the web used to compute the plastic moment (kip) (D6.1)
- p = pitch of shear connectors along the longitudinal axis (in.); staggered pitch between two adjacent lines of staggered bolt holes (in.) (6.10.10.1.2) (6.13.2.6.3)
- Q = first moment of the transformed short-term area of the concrete deck about the neutral axis of the short-term composite section, or optionally in regions of negative flexure of straight girders only, the first moment of the longitudinal reinforcement about the neutral axis of the composite section if the concrete is not considered to be effective in tension in computing the range of longitudinal stress (in.³); first moment of one-half the effective box-flange area at an interior pier about the neutral axis of the effective internal diaphragm section (in.³); slender element reduction factor determined as specified in Article 6.9.4.2. Q shall be taken equal to 1.0 for bearing stiffeners (6.9.4.1.1) (6.10.10.1.2) (C6.11.8.1.1)
- Q_n = nominal shear resistance of a single shear connector (kip) (6.10.10.4.1)
- Q_r = factored shear resistance of a single shear connector (kip) (6.10.10.4.1)
- Q_u = prying tension per bolt due to the factored loads (kip) (6.13.2.10.4)
- R = transition radius of welded attachments as shown in Table 6.6.1.2.3-1 (in.); minimum girder radius within a panel (ft); radius of curvature (ft); reduction factor applied to the factored shear resistance of bolts passing through fillers (6.6.1.2.3) (6.7.4.2) (6.7.7.2) (6.13.6.1.5)
- R_1 = constant which when multiplied by $\sqrt{kE/F_{yc}}$ defines the slenderness ratio for a box flange equal to 0.6 times the flange slenderness at which the elastic buckling stress for the flange equals the resistance for yielding under combined normal and shear stress (6.11.8.2.2)
- R_2 = constant which when multiplied by $\sqrt{kE/F_{yc}}$ defines the slenderness ratio for a box flange equal to the flange slenderness at which the elastic buckling stress for the flange equals F_{yr} (6.11.8.2.2)
- R_b = web load-shedding factor (6.10.1.6) (6.10.1.10.2) (6.11.8.2.2)
- R_{cf} = absolute value of the ratio of F_{cf} to f_{cf} at a point of splice (C6.13.6.1.4b)
- R_h = hybrid factor (6.10.1.10.1) (6.11.8.2.2)
- R_n = nominal resistance of a bolt, connection or connected material (kip) or (ksi); nominal resistance to a concentrated loading (kip) (6.13.2.2) (D6.5.2)
- R_p = reduction factor for holes taken equal to 0.90 for bolt holes punched full size and 1.0 for bolt holes drilled full size or subpunched and reamed to size (6.8.2.1) (6.13.4) (6.13.5.3)
- $(R_{pB})_n$ = nominal bearing resistance on pins (kip) (6.7.6.2.2)
- $(R_{pB})_r$ = factored bearing resistance on pins (kip) (6.7.6.2.2)
- R_{pc} = web plastification factor for the compression flange (A6.1.3)
- R_{pt} = web plastification factor for the tension flange (A6.1.4)
- R_r = factored resistance of a bolt, connection or connected material (kip) or (ksi) (6.13.2.2)
- $(R_{sb})_n$ = nominal bearing resistance for the fitted end of bearing stiffeners (kip) (6.10.11.2.3)
- $(R_{sb})_r$ = factored bearing resistance for the fitted end of bearing stiffeners (kip) (6.10.11.2.3)

R_u	=	factored concentrated load or bearing reaction (kip) (D6.5.2)
r	=	minimum radius of gyration of a tension or compression member (in.); radius of gyration of a built-up member about an axis perpendicular to a perforated plate (in.); radius of gyration of a longitudinal web stiffener including an effective width of web taken about the neutral axis of the combined section (in.) (6.8.4) (6.9.4.3.2) (6.10.11.3.3)
r_i	=	minimum radius of gyration of an individual component shape (in.) (C6.9.4.3.1)
r_{ib}	=	radius of gyration of an individual component shape relative to its centroidal axis parallel to the member axis of buckling (in.) (6.9.4.3.1)
r_n	=	nominal bearing pressure at bolt holes (ksi) (C6.13.2.9)
r_s	=	radius of gyration of a structural steel shape, pipe or tubing about the plane of buckling (in.); radius of gyration about the axis normal to the plane of buckling (in.) (6.9.4.1.2)
r_t	=	effective radius of gyration for lateral torsional buckling (in.) (6.10.8.2.3)
r_{ts}	=	radius of gyration used in the determination of L_r (in.) (6.12.2.2.5)
r_x	=	radius of gyration about the geometric axis of the angle parallel to the connected leg (in.); radius of gyration about the x -axis (in.) (6.9.4.1.3) (6.9.4.4)
r_y	=	radius of gyration of a steel section with respect to a vertical axis in the plane of the web (in.); radius of gyration about the y -axis (in.) (6.9.4.1.3) (6.12.2.2.5) (CB6.2.4)
r_{yc}	=	radius of gyration of the compression flange with respect to a vertical axis in the plane of the web (in.) (C6.10.8.2.3)
r_z	=	radius of gyration about the minor principal axis of the angle (in.) (6.9.4.4)
r_σ	=	desired bending stress ratio in a horizontally curved I-girder, taken equal to $ f_c/f_{bu} $ (C6.7.4.2)
\bar{r}_O	=	polar radius of gyration about the shear center (in.) (6.9.4.1.3)
S	=	elastic section modulus (in. ³); elastic section modulus about the axis of bending (in. ³) (C6.12.2.2.1) (6.12.2.2.2) (6.12.2.2.3)
S_{eff}	=	effective elastic section modulus about the axis of bending determined using an effective width of the compression flange b_e (in. ³) (6.12.2.2.2)
S_{LT}	=	long-term composite elastic section modulus (in. ³) (D6.2.2)
S_{NC}	=	noncomposite elastic section modulus (in. ³) (D6.2.2)
S_s	=	elastic section modulus of a transverse flange stiffener (in. ³) (C6.11.11.2)
S_{ST}	=	short-term composite elastic section modulus (in. ³) (D6.2.2)
S_x	=	elastic section modulus to an inclined bottom flange of a variable web depth member (in. ³) elastic section modulus about the x -axis (in. ³); section modulus about the major geometric axis (in. ³) (6.12.2.2.5) (6.12.2.2.7) (C6.10.1.4)
S_{xc}	=	elastic section modulus about the major axis of the section to the compression flange taken as M_{yc}/F_{yc} (in. ³); elastic section modulus with respect to the compression flange (in. ³) (C6.8.2.3) (6.12.2.2.4)
S_{xt}	=	elastic section modulus about the major axis of the section to the tension flange taken as M_{yt}/F_{yt} (in. ³) (C6.8.2.3)
S_y	=	elastic section modulus about the axis parallel with the web (in. ³) (6.12.2.2.1)
s	=	pitch of any two consecutive bolts in a staggered chain (in.); longitudinal spacing of transverse reinforcement in a concrete-encased shape (in.); spacing of bolts on a single line or in a staggered pattern adjacent to a free edge of an outside plate or shape (in.); vertical pitch of bolts in a web splice (in.) (6.8.3) (6.12.3.1) (6.13.2.6.2) (C6.13.6.1.4b)
s_t	=	maximum transverse spacing between shear connectors on a composite box flange (in.) (6.11.10)
T	=	internal torque in a box section due to the factored loads (kip-in.); internal torque due to the factored loads (kip-in.); base metal thickness of the thicker part joined in a fillet-welded connection given in Table 6.13.3.4-1 (in.) (C6.11.1.1) (6.13.3.4)
T_n	=	nominal resistance of a bolt in axial tension or in combined axial tension and shear (kip) (6.13.2.2)
T_r	=	factored resistance of a bolt in axial tension or in combined axial tension and shear (kip) (6.13.2.2)
T_u	=	tensile force per bolt due to Load Combination Service II (kip) (6.13.2.11)
t	=	thickness of plate or plates (in.); thickness of tube or wall (in.); thickness of the thinner outside plate or shape (in.); thickness of the connected material (in.); thickness of the thinnest connected part (in.); thickness of tube (in.); width of the rectangular bar parallel to the axis of bending (in.) (C6.7.4.3) (6.9.4.2.1) (6.12.1.2.3c) (6.12.2.2.3) (6.12.2.2.7) (6.13.2.6.2) (6.13.2.9) (6.13.2.10.4)
t_b	=	thickness of the flange transmitting the concentrated force in a rigid-frame connection (in.) (6.13.7.2)
t_c	=	thickness of the flange of the member to be stiffened in a rigid-frame connection (in.) (6.13.7.2)
t_f	=	flange thickness (in.); flange thickness of a channel shear connector (in.); thickness of the flange resisting a concentrated load or bearing reaction (in.) (C6.9.4.1.3) (6.10.2.2) (6.10.10.4.3) (6.12.2.2.4) (6.12.2.2.5) (D6.5.3)

t_{fc}	=	thickness of the compression flange (in.); design wall thickness of the compression flange taken equal to 0.93 times the nominal wall thickness for electric-resistance-welded HSS and taken equal to the nominal wall thickness for all others (in.) (6.10.1.10.2) (6.12.2.2.2)
t_{ft}	=	thickness of the tension flange (in.) (C6.10.9.1)
t_p	=	thickness of a transversely loaded plate (in.); thickness of a projecting stiffener element (in.) (6.6.1.2.5) (6.10.11.1.2)
t_s	=	thickness of a concrete deck (in.); thickness of a longitudinal web or flange stiffener (in.); thickness of an arch-rib stiffener (in.) (6.10.1.10.2) (6.10.11.3.2) (6.14.4.2)
t_w	=	web thickness (in.); web or tube thickness (in.); web thickness of a channel shear connector (in.); thickness of the web to be stiffened in a rigid-frame connection (in.); web thickness of an arch rib (in.); design wall thickness of the web taken equal to 0.93 times the nominal wall thickness for electric-resistance-welded HSS and taken equal to the nominal wall thickness for all others (in.) (6.7.7.2) (6.9.4.2) (6.10.10.4.3) (6.12.2.2.2) (6.12.2.2.5) (6.13.7.2) (6.14.4.2)
U	=	reduction factor to account for shear lag in connections subjected to a tension load (6.6.1.2.3) (6.8.2.1)
U_{bs}	=	reduction factor for block shear rupture resistance taken equal to 0.50 when the tension stress is non-uniform and 1.0 when the tension stress is uniform (6.13.4)
V	=	additional shear force for built-up members with perforated plates (kip); factored vertical shear force in the internal interior-pier diaphragm of a box section due to flexure plus St. Venant torsion (kip) (6.9.4.3.2) (C6.11.8.1.1)
V_{cr}	=	shear-buckling resistance (kip) (6.10.3.3)
V_f	=	vertical shear force range under the Fatigue Load Combination (kip) (6.10.10.1.2)
V_{fat}	=	longitudinal fatigue shear range per unit length (kip/in.) (6.10.10.1.2)
V_n	=	nominal shear resistance (kip) (6.10.9.1) (6.12.1.2.3a)
V_p	=	plastic shear force (kip) (6.10.9.2)
V_r	=	factored shear resistance (kip) (6.12.1.2.3)
V_{sr}	=	horizontal fatigue shear range per unit length (kip/in.); vector sum of the horizontal fatigue shear range and the torsional fatigue shear range in the concrete deck for a composite box flange (kip/in.) (6.10.10.1.2) (6.11.10)
V_u	=	shear due to the factored loads (kip); vertical shear due to the factored loads on one inclined web of a box section (kip) (6.7.6.2.1) (6.11.9)
V_{ui}	=	shear due to the factored loads along one inclined web of a box section (kip) (6.11.9)
V_{uw}	=	design shear for the web at a point of splice (kip) (6.13.6.1.4b)
w	=	center-to-center distance between the top flanges of a box section (in.); plate width (in.); effective length of deck assumed acting radial to the girder (in.); larger of the width of a box flange between longitudinal flange stiffeners or the distance from a web to the nearest longitudinal flange stiffener (in.) (C6.7.5.3) (6.8.2.2) (6.10.10.1.2) (6.11.8.2.3)
x_o	=	distance along the x -axis between the shear center and centroid of the cross-section (in.) (6.9.4.1.3)
\bar{x}	=	distance from the centroid of the member to the surface of the gusset or connection plate (in.); perpendicular distance from the plane of the connection to the centroid of the tension member cross-section or the portion of the cross-section tributary to the connection (in.); dimensional parameter used in calculating the shear lag reduction factor U (in.) (6.6.1.2.3) (6.8.2.2)
Y_o	=	distance from the neutral axis to the extreme outer fiber of the cross-section (in.) (6.7.7.3)
y_o	=	distance along the y -axis between the shear center and centroid of the cross-section (in.) (6.9.4.1.3)
y	=	distance from the plastic neutral axis to the top of the element where the plastic neutral axis is located (in.) (D6.1)
Z	=	curvature parameter for determining required longitudinal web stiffener rigidity; plastic section modulus (in. ³); plastic section modulus about the axis of bending (in. ³) (6.10.11.3.3) (6.12.2.2.2) (6.12.2.2.3) (6.12.2.2.7) (6.12.2.3.1)
Z_r	=	shear fatigue resistance of an individual shear connector (kip) (6.10.10.1.2)
Z_x	=	plastic section modulus about the x -axis (in. ³) (6.12.2.2.4) (6.12.2.2.5)
Z_y	=	plastic section modulus about the axis parallel with the web (in. ³) (6.12.2.2.1)
α	=	separation ratio = $h/2r_{ib}$; factor defining the sloping straight line representing the finite-life portion of the fatigue shear resistance of an individual stud shear connector; factor for flange splice design generally equal to 1.0, except that a lower value equal to F_n/F_{yf} may be used for flanges where F_n is less than F_{yf} (6.9.4.3.1) (6.10.10.2) (6.13.6.1.4c)
β	=	factor equal to two times the area of the web based on D_n divided by A_{fn} used in computing the hybrid factor; factor defining the approximate ratio of D_p to $D_f/7.5$ at which a composite section in positive flexure reaches M_p ; curvature correction factor for longitudinal web stiffener rigidity (6.10.1.10.1) (C6.10.7.1.2) (6.10.11.3.3)
η	=	load modifier related to ductility, redundancy and operational importance (C6.6.1.2.2)
γ	=	load factor specified in Table 3.4.1-1; the ratio of A_f to A_p for filler plate design (6.6.1.2.2) (6.13.6.1.5)

Δ	=	total camber at any section along the effective span length of a heat-curved girder, including compensatory camber to account for possible camber loss (in.); reduction factor for the maximum stress in a box flange (6.7.7.3) (6.11.3.2)
Δ_{DL}	=	camber at any point along the effective span length of a heat-curved girder to compensate for deflection due to dead load or any other specified loads (in.) (6.7.7.3)
(Δf)	=	live load stress range due to the passage of the fatigue load (ksi) (6.6.1.2.2)
$(\Delta F)^c_n$	=	nominal fatigue resistance for Detail Category C (ksi) (6.6.1.2.5)
$(\Delta F)_n$	=	nominal fatigue resistance (ksi) (6.6.1.2.2) (6.6.1.2.5)
(ΔF_{TH})	=	constant amplitude fatigue threshold (ksi) (6.6.1.2.5)
Δ_M	=	maximum value of Δ_{DL} within the effective span length of a heat-curved girder (in.) (6.7.7.3)
Δ_R	=	additional camber to compensate for the possible loss of camber in a heat-curved girder (in.) (6.7.7.3)
λ	=	normalized column slenderness factor (6.9.5.1)
λ_f	=	slenderness ratio for the compression flange; slenderness ratio for the flange; compression-flange slenderness = b_f/t_{fc} ; flange slenderness = $b_f/2t_f$; flange slenderness of the channel = b_f/t_f (6.10.8.2.2) (6.11.8.2.2) (6.12.2.2.1) (6.12.2.2.2) (6.12.2.2.4) (6.12.2.2.5)
λ_{pf}	=	limiting slenderness ratio for a compact flange; limiting slenderness for a compact flange (6.10.8.2.2) (6.12.2.2.2) (6.12.2.2.4) (6.12.2.2.5)
λ_{pw}	=	limiting slenderness for a compact web (6.12.2.2.2) (6.12.2.2.5)
$\lambda_{pw(De)}$	=	limiting slenderness ratio for a compact web corresponding to $2D_o/t_w$ (A6.2.2)
$\lambda_{pw(Dcp)}$	=	limiting slenderness ratio for a compact web corresponding to $2D_{cp}/t_w$ (A6.2.1)
λ_{rf}	=	limiting slenderness ratio for a noncompact flange; limiting slenderness for a noncompact flange (6.10.8.2.2) (6.12.2.2.2) (6.12.2.2.4)
λ_{rw}	=	limiting slenderness ratio for a noncompact web (6.10.1.10.2)
λ_w	=	slenderness ratio for the web based on the elastic moment (A6.2.2)
Ψ	=	ratio of the total cross-sectional area to the cross-sectional area of both flanges; constant used in determining the required moment of inertia of longitudinal stiffeners for box flanges (6.7.7.2) (6.11.11.2)
ρ	=	factor equal to the smaller of F_{yw}/f_n and 1.0 used in computing the hybrid factor (6.10.1.10.1)
ρ_t	=	the larger of F_{yw}/F_{crs} and 1.0 (6.10.11.1.3)
θ	=	angle of inclination of the bottom flange of a variable web depth member (degrees); angle of inclination of the web plate of a box section to the vertical (degrees) (C6.10.1.4) (6.11.9)
θ_p	=	plastic rotation at an interior-pier section (radians) (B6.6.2)
θ_{RL}	=	plastic rotation at which the moment at an interior-pier section nominally begins to decrease with increasing θ_p (radians) (6.10.7.1.2)
σ_{flg}	=	range of longitudinal fatigue stress in the bottom flange without consideration of flange lateral bending (ksi) (6.10.10.1.2)
ϕ	=	resistance factor; resistance factor for resistance during pile driving; resistance factor for concrete in tension specified in Article 5.5.4.2.1 (6.5.4.2) (6.10.1.7)
ϕ_b	=	resistance factor for bearing (6.5.4.2)
ϕ_{bb}	=	resistance factor for bolts bearing on material (6.5.4.2)
ϕ_{bs}	=	resistance factor for block shear (6.5.4.2)
ϕ_c	=	resistance factor for axial compression (6.5.4.2)
ϕ_{e1}	=	resistance factor for shear on the effective area of the weld metal in complete penetration welds; resistance factor for tension normal to the effective area of the weld metal in partial penetration welds (6.5.4.2)
ϕ_{e2}	=	resistance factor for shear parallel to the axis of the weld metal in partial penetration welds; resistance factor for shear in the throat of the weld metal in fillet welds (6.5.4.2)
ϕ_f	=	resistance factor for flexure (6.5.4.2) (6.11.8.2.2)
ϕ_s	=	resistance factor for shear in bolts (6.5.4.2)
ϕ_{sc}	=	resistance factor for shear connectors (6.5.4.2)
ϕ_{sd}	=	resistance factor for shakedown (CB6.4.2.1)
ϕ_t	=	resistance factor for tension in bolts (6.5.4.2)
ϕ_u	=	resistance factor for fracture on the net section of tension members (6.5.4.2)
ϕ_v	=	resistance factor for shear (6.5.4.2) (6.11.8.2.2)
ϕ_{vu}	=	resistance factor for shear rupture of connection elements as specified in Article 6.5.4.2 (6.13.5.3)

- ϕ_w = resistance factor for web crippling (6.5.4.2)
 ϕ_y = resistance factor for yielding on the gross section of tension members (6.5.4.2)

6.4—MATERIALS

6.4.1—Structural Steels

Structural steels shall conform to the requirements specified in Table 6.4.1-1, and the design shall be based on the minimum properties indicated.

The modulus of elasticity and the thermal coefficient of expansion of all grades of structural steel shall be assumed as 29,000 ksi and 6.5×10^{-6} in./in./°F, respectively.

AASHTO M 270M/M 270, Grade 36 (ASTM A709/A709M, Grade 36), may be used in thicknesses over 4.0 in. for nonstructural applications or bearing assembly components.

C6.4.1

The term yield strength is used in these Specifications as a generic term to denote either the minimum specified yield point or the minimum specified yield strength.

The main difference, and in most cases the only difference, between AASHTO and ASTM requirements is the inclusion of mandatory notch toughness and weldability requirements in the AASHTO Material Standards. Steels meeting the AASHTO Material requirements are prequalified for use in welded bridges.

The yield strength in the direction parallel to the direction of rolling is of primary interest in the design of most steel structures. In welded bridges, notch toughness is of equal importance. Other mechanical and physical properties of rolled steel, such as anisotropy, ductility, formability, and corrosion resistance, may also be important to ensure the satisfactory performance of the structure.

No specification can anticipate all of the unique or especially demanding applications that may arise. The literature on specific properties of concern and appropriate supplementary material production or quality requirements, provided in the AASHTO and ASTM Material Specifications and the *AASHTO/AWS D1.5M/D1.5 Bridge Welding Code*, should be considered, if appropriate.

AASHTO M 270M/M 270 (ASTM A709/A709M), Grade HPS 70W, has replaced AASHTO M 270M/M 270 (ASTM A709/A709M), Grade 70W, and AASHTO M 270M/M 270 (ASTM A709/A709M), Grade HPS 100W, has replaced AASHTO M 270M/M 270 (ASTM A709/A709M), Grade 100 and 100W in Table 6.4.1-1. The intent of these replacements is to encourage the use of HPS steel over the older bridge steels of the same strength level due to its enhanced properties. The older steels are still available, but are not recommended for use and should be used only with the approval of the Owner. The maximum available plate lengths of AASHTO M 270M/M 270 (ASTM A709/A709M), Grade HPS 70W and HPS 100W, are a function of the processing of the plate, with longer lengths of Grade HPS 70W produced as as-rolled plate. The maximum available plate lengths of these steels should be determined in consultation with the material producers.

Quenched and tempered alloy steel structural shapes and seamless mechanical tubing with a specified maximum tensile strength not exceeding 140 ksi for structural shapes or 145 ksi for seamless mechanical tubing may be used, provided that:

- The material meets all other mechanical and chemical requirements of AASHTO M 270M/M 270 (ASTM A709/A709M), Grade HPS 100W, and
- The design is based upon the minimum properties specified for AASHTO M 270M/M 270 (ASTM A709/A709M), Grade HPS 100W.

Structural tubing shall be either cold-formed welded or seamless tubing conforming to ASTM A500, Grade B or Grade C, or ASTM A847; or hot-formed welded or seamless tubing conforming to ASTM A501 or ASTM A618.

Thickness limitations relative to rolled shapes and groups shall comply with AASHTO M 160M/M 160 (ASTM A6/A6M).

ASTM A500 cautions that structural tubing manufactured to that specification may not be suitable for applications involving dynamically loaded elements in welded structures where low-temperature notch-toughness properties may be important. As such, the use of this material should be carefully examined with respect to its specific application in consultation with the Owner. Where this material is contemplated for use in applications where low-temperature notch-toughness properties are deemed important, consideration should be given to requiring that the material satisfy the Charpy V-notch toughness requirements specified in Article 6.6.2.

Table 6.4.1-1—Minimum Mechanical Properties of Structural Steel by Shape, Strength, and Thickness

AASHTO Designation	M 270M/ M 270 Grade 36	M 270M/ M 270 Grade 50	M 270M/ M 270 Grade 50S	M 270M/ M 270 Grade 50W	M 270M/ M 270 Grade HPS 50W	M 270M/ M 270 Grade HPS 70W	M 270M/ M 270 Grade HPS 100W	
Equivalent ASTM Designation	A709/ A709M Grade 36	A709/ A709M Grade 50	A709/ A709M Grade 50S	A709/ A709M Grade 50W	A709/ A709M Grade HPS 50W	A709/ A709M Grade HPS 70W	A709/ A709M Grade HPS 100W	
Thickness of Plates, in.	Up to 4.0 incl.	Up to 4.0 incl.	Not Applicable	Up to 4.0 incl.	Up to 4.0 incl.	Up to 4.0 incl.	Up to 2.5 incl.	Over 2.5 to 4.0 incl.
Shapes	All Groups	All Groups	All Groups	All Groups	Not Applicable	Not Applicable	Not Applicable	Not Applicable
Minimum Tensile Strength, F_u , ksi	58	65	65	70	70	85	110	100
Specified Minimum Yield Point or Specified Minimum Yield Strength, F_y , ksi	36	50	50	50	50	70	100	90

6.4.2—Pins, Rollers, and Rockers

Steel for pins, rollers, and expansion rockers shall conform to the requirements in Table 6.4.2-1, Table 6.4.1-1, or Article 6.4.7.

Expansion rollers shall be not less than 4.0 in. in diameter.

Table 6.4.2-1—Minimum Mechanical Properties of Pins, Rollers, and Rockers by Size and Strength

AASHTO Designation with Size Limitations	M 169 4.0 in. in dia. or less	M 102M/ M 102 to 20.0 in. in dia.	M 102M/ M 102 to 20.0 in. in dia.	M 102M/ M 102 to 10.0 in. in dia.	M 102M/ M 102 to 20.0 in. in dia.
ASTM Designation Grade or Class	A108 Grades 1016 to 1030 incl.	A668/ A668M Class C	A668/ A668M Class D	A668/ A668M Class F	A668/ A668M Class G
Specified Minimum Yield Point, F_y , ksi	36	33	37.5	50	50

6.4.3—Bolts, Nuts, and Washers

6.4.3.1—Bolts

Bolts used as structural fasteners shall conform to one of the following:

- The Standard Specification for Carbon Steel Bolts and Studs, 60 ksi Tensile Strength, ASTM A307 Grade A or B,
- The Standard Specification for Structural Bolts, Steel, Heat-Treated, 120/105 ksi Minimum Tensile Strength with a required minimum tensile strength of 120 ksi for diameters 0.5 through 1.0 in. and 105 ksi for diameters 1.125 through 1.5 in., AASHTO M 164 (ASTM A325), or
- The Standard Specification for Heat-Treated Steel Structural Bolts, 150 ksi Minimum Tensile Strength, AASHTO M 253 (ASTM A490).

Type 1 bolts should be used with steels other than weathering steel. Type 3 bolts conforming with either AASHTO M 164 (ASTM A325) or AASHTO M 253 (ASTM A490) shall be used with weathering steels. AASHTO M 164 (ASTM A325) Type 1 bolts may be either hot-dip galvanized in accordance with AASHTO M 232M/M 232 (ASTM A153/A153M), Class C, or mechanically galvanized in accordance with AASHTO M 298 (ASTM B695), Class 50, when approved by the Engineer. Galvanized bolts shall be retested after galvanizing, as required by AASHTO M 164 (ASTM A325).

AASHTO M 253 (ASTM A490) bolts shall not be galvanized.

C6.4.3.1

The ASTM standard for A307 bolts covers three grades of fasteners, A, B, and C. Grade A and B bolts may be used under this Specification as appropriate. There is no AASHTO standard corresponding to ASTM A307.

Washers, nuts, and bolts of any assembly shall be galvanized by the same process. The nuts should be overtapped to the minimum amount required for the fastener assembly and shall be lubricated with a lubricant containing a visible dye.

Anchor Bolts shall conform to one of the following:

- ASTM A307 Grade C, or
- ASTM F1554.

6.4.3.2—Nuts

6.4.3.2.1—Nuts Used with Structural Fasteners

Nuts used with structural fasteners shall conform to the following as appropriate.

Except as noted below, nuts for AASHTO M 164 (ASTM A325) bolts shall conform to the Standard Specification for Carbon and Alloy Steel Nuts, AASHTO M 291 (ASTM A563), Grades DH, DH3, C, C3, and D.

Nuts for AASHTO M 253 (ASTM A490) bolts shall conform to the requirements of AASHTO M 291 (ASTM A563), Grades DH and DH3.

Nuts to be galvanized shall be heat treated Grade DH. The provisions of Article 6.4.3.1 shall apply. All galvanized nuts shall be lubricated with a lubricant containing a visible dye.

Plain nuts shall have a minimum hardness of 89 HRB.

Nuts to be used with AASHTO M 164 (ASTM A325) Type 3 bolts shall be of Grade C3 or DH3. Nuts to be used with AASHTO M 253 (ASTM A490) Type 3 bolts shall be of Grade DH3.

6.4.3.2.2—Nuts Used with Anchor Bolts

Nuts used with anchor bolts shall conform to the following as appropriate.

Nuts for ASTM A307 Grade C and for ASTM F1554 anchor bolts shall conform to AASHTO M 291 (ASTM A563) for appropriate grade and size of anchor bolt.

Nuts to be galvanized shall be heat treated Grade DH or DH3. The provisions of Article 6.4.3.1 shall apply. All galvanized nuts should be lubricated with a lubricant containing a visible dye.

6.4.3.3—Washers

Washers shall conform to the Standard Specification for Hardened Steel Washers, AASHTO M 293 (ASTM F436).

The provisions of Article 6.4.3.1 shall apply to galvanized washers.

The purpose of the dye is to allow a visual check to be made for the lubricant at the time of field installation.

Black bolts must be oily to the touch when delivered and installed.

ASTM A307 Grade C are nonheaded anchor bolts intended for structural anchorage purposes. There is no AASHTO standard corresponding to ASTM F1554.

C6.4.3.2

C6.4.3.3

Installation provisions for washers are covered in the *AASHTO LRFD Bridge Construction Specifications* (2010).

6.4.3.4—Alternative Fasteners

Other fasteners or fastener assemblies not specified heretofore, such as those conforming to the requirements of ASTM F1852, may be used subject to the approval of the Engineer, provided that:

- They meet materials, manufacturing, and chemical composition requirements of AASHTO M 164 (ASTM A325) or AASHTO M 253 (ASTM A490),
- They meet mechanical property requirements of the same specification in full size tests, and
- The body diameter and bearing areas under the head and nut, or their equivalent, shall not be less than those provided by a bolt and nut of the same nominal dimensions prescribed in Articles 6.4.3.1 and 6.4.3.2,

Such alternate fasteners may differ in other dimensions from those of the bolts, nuts, and washers specified in Articles 6.4.3.1 through 6.4.3.3.

6.4.3.5—Load Indicator Devices

Load-indicating devices conforming to the requirements of ASTM F959 may be used in conjunction with bolts, nuts and washers. Load-indicating devices which are incorporated into assemblies with hardened heavy hex AASHTO M 291 (ASTM A563) Grade DH nuts shall be considered permissible for use, provided both the load-indicating device and heavy hex nut meet the mechanical property requirements of their respective ASTM standards.

Alternate direct tension indicating devices may be used, subject to the approval of the Engineer.

6.4.4—Stud Shear Connectors

Shear connector studs shall be made from cold-drawn bars, Grades 1015, 1018, or 1020, either semi or fully killed, conforming to AASHTO M 169 (ASTM A108), and shall have a specified minimum yield and tensile strength of 50.0 ksi and 60.0 ksi, respectively. If flux retaining caps are used, the steel for the caps shall be of a low carbon grade suitable for welding and shall conform to ASTM A109.

6.4.5—Weld Metal

Weld metal shall conform to the requirements of the *AASHTO/AWS D1.5M/D1.5 Bridge Welding Code*.

C6.4.3.5

Installation provisions for load-indicating devices are covered in the *AASHTO LRFD Bridge Construction Specifications* (2010).

An assembly comprised of a load-indicating device affixed to a hardened heavy hex structural nut by the fastener manufacturer is also referred to as a captive DTI/nut.

C6.4.4

Physical properties, test methods, and certification of steel shear connectors are covered in the *AASHTO LRFD Bridge Construction Specifications* (2010).

C6.4.5

The AWS designation systems are not consistent. For example, there are differences between the system used for designating electrodes for shielded metal arc welding and the system used for designating submerged arc welding. Therefore, when specifying weld metal and/or flux by AWS designation, the applicable specification should be reviewed to ensure a complete understanding of the designation reference.

6.4.6—Cast Metal

6.4.6.1—Cast Steel and Ductile Iron

Cast steel shall conform to one of the following:

- AASHTO M 103M/M 103 (ASTM A27/A27M), Grade 70-36, unless otherwise specified;
- AASHTO M 163M/M 163 (ASTM A743/A743M) Grade CA15, unless otherwise specified.

Ductile iron castings shall conform to ASTM A536, Grade 60-40-18, unless otherwise specified.

6.4.6.2—Malleable Castings

Malleable castings shall conform to ASTM A47, Grade 35018. The specified minimum yield strength shall not be less than 35.0 ksi.

6.4.6.3—Cast Iron

Cast iron castings shall conform to AASHTO M 105 (ASTM A48), Class 30.

6.4.7—Stainless Steel

Stainless steel may conform to one of the following:

- ASTM A176,
- ASTM A240,
- ASTM A276, or
- ASTM A666.

Stainless steel not conforming to the above-listed specifications may be used, provided that it conforms to the chemical and mechanical requirements of one of the above-listed specifications or other published specifications that establish its properties and suitability and that it is subjected to analyses, tests, and other controls to the extent and in the manner prescribed by one of the listed specifications.

6.4.8—Cables

6.4.8.1—Bright Wire

Bright wire shall conform to ASTM A510.

6.4.8.2—Galvanized Wire

Galvanized wire shall conform to ASTM A641.

6.4.8.3—Epoxy-Coated Wire

Epoxy-coated wire shall conform to ASTM A99.

6.4.8.4—Bridge Strand

Bridge strand shall conform to ASTM A586 or ASTM A603.

6.5—LIMIT STATES

6.5.1—General

The structural behavior of components made of steel or steel in combination with other materials shall be investigated for each stage that may be critical during construction, handling, transportation, and erection as well as during the service life of the structure of which they are part.

Structural components shall be proportioned to satisfy the requirements at strength, extreme event, service, and fatigue limit states.

6.5.2—Service Limit State

The provisions of Article 2.5.2.6 shall apply as applicable.

Flexural members shall be investigated at the service limit state as specified in Articles 6.10 and 6.11.

6.5.3—Fatigue and Fracture Limit State

Components and details shall be investigated for fatigue as specified in Article 6.6.

The fatigue load combinations specified in Table 3.4.1-1 and the fatigue live load specified in Article 3.6.1.4 shall apply.

Flexural members shall be investigated at the fatigue and fracture limit state as specified in Articles 6.10 and 6.11.

Bolts subject to tensile fatigue shall satisfy the provisions of Article 6.13.2.10.3.

Fracture toughness requirements shall be in conformance with Article 6.6.2.

6.5.4—Strength Limit State

6.5.4.1—General

Strength and stability shall be considered using the applicable strength load combinations specified in Table 3.4.1-1.

C6.5.2

The intent of the service limit state provisions specified for flexural members in Articles 6.10 and 6.11 is primarily to prevent objectionable permanent deformations due to localized yielding that would impair rideability under expected severe traffic loadings.

6.5.4.2—Resistance Factors

Resistance factors, ϕ , for the strength limit state shall be taken as follows:

- For flexure $\phi_f = 1.00$
- For shear $\phi_v = 1.00$
- For axial compression, steel only $\phi_c = 0.90$
- For axial compression, composite $\phi_c = 0.90$
- For tension, fracture in net section $\phi_u = 0.80$
- For tension, yielding in gross section $\phi_y = 0.95$
- For bearing on pins in reamed, drilled or bored holes and on milled surfaces $\phi_b = 1.00$
- For bolts bearing on material $\phi_{bb} = 0.80$
- For shear connectors $\phi_{sc} = 0.85$
- For A 325 and A 490 bolts in tension $\phi_t = 0.80$
- For A 307 bolts in tension $\phi_t = 0.80$
- For F 1554 bolts in tension $\phi_t = 0.80$
- For A 307 bolts in shear $\phi_s = 0.75$
- For F 1554 bolts in shear $\phi_s = 0.75$
- For A 325 and A 490 bolts in shear $\phi_s = 0.80$
- For block shear $\phi_{bs} = 0.80$
- For shear, rupture in connection element $\phi_{vu} = 0.80$
- For web crippling $\phi_w = 0.80$
- For weld metal in complete penetration welds:
 - shear on effective area $\phi_{e1} = 0.85$
 - tension or compression normal to effective area same as base metal
 - tension or compression parallel to axis of the weld same as base metal
- For weld metal in partial penetration welds:
 - shear parallel to axis of weld $\phi_{e2} = 0.80$
 - tension or compression parallel to axis of weld same as base metal
 - compression normal to the effective area same as base metal
 - tension normal to the effective area $\phi_{e1} = 0.80$
- For weld metal in fillet welds:
 - tension or compression parallel to axis of the weld same as base metal
 - shear in throat of weld metal $\phi_{e2} = 0.80$
- For resistance during pile driving $\phi = 1.00$

C6.5.4.2

Base metal ϕ as appropriate for resistance under consideration.

- For axial resistance of piles in compression and subject to damage due to severe driving conditions where use of a pile tip is necessary:
 - H-piles $\phi_c = 0.50$
 - pipe piles $\phi_c = 0.60$
- For axial resistance of piles in compression under good driving conditions where use of a pile tip is not necessary:
 - H-piles $\phi_c = 0.60$
 - pipe piles $\phi_c = 0.70$
- For combined axial and flexural resistance of undamaged piles:
 - axial resistance for H-piles $\phi_c = 0.70$
 - axial resistance for pipe piles $\phi_c = 0.80$
 - flexural resistance $\phi_f = 1.00$
- For shear connectors in tension $\phi_{st} = 0.75$

The basis for the resistance factors for driven steel piles is described in Article 6.15.2. Further limitations on usable resistance during driving are specified in Article 10.7.8.

Indicated values of ϕ_c and ϕ_f for combined axial and flexural resistance are for use in interaction equations in Article 6.9.2.2.

6.5.5—Extreme Event Limit State

All applicable extreme event load combinations in Table 3.4.1-1 shall be investigated. For Extreme Event I, γ_p for *DC* and *DW* loads shall be taken to be 1.0.

All resistance factors for the extreme event limit state, except those specified for bolts and shear connectors, shall be taken to be 1.0.

All resistance factors for ASTM A307 Grade C and ASTM F1554 bolts used as anchor bolts for the extreme event limit state shall be taken to be 1.0.

Bolted slip-critical connections within a seismic load path shall be proportioned according to the requirements of Article 6.13.2.1.1. The connections shall also be proportioned to provide shear, bearing, and tensile resistance in accordance with Articles 6.13.2.7, 6.13.2.9, and 6.13.2.10, as applicable, at the extreme event limit state. Standard holes or short-slotted holes normal to the line of force shall be used in such connections.

C6.5.5

During earthquake motion, there is the potential for full reversal of design load and inelastic deformations of members or connections, or both. Therefore, slip of bolted joints located within a seismic load path cannot and need not be prevented during a seismic event. A special inspection of joints and connections, particularly in fracture critical members, should be performed as described in *The Manual for Bridge Evaluation* (2011) after a seismic event.

To prevent excessive deformations of bolted joints due to slip between the connected plies under earthquake motions, only standard holes or short-slotted holes normal to the line of force are permitted in bolted joints located within a seismic load path. For such holes, the upper limit of $2.4dtF_u$ on the bearing resistance is intended to prevent elongations due to bearing deformations from exceeding approximately 0.25 in. It should be recognized, however, that the actual bearing load in a seismic event may be much larger than that anticipated in design and the actual deformation of the holes may be larger than this theoretical value. Nonetheless, the specified upper limit on the nominal bearing resistance should effectively minimize damage in moderate seismic events.

6.6—FATIGUE AND FRACTURE CONSIDERATIONS

6.6.1—Fatigue

6.6.1.1—General

Fatigue shall be categorized as load- or distortion-induced fatigue.

C6.6.1.1

In the *AASHTO Standard Specifications for Highway Bridges* (2002), the provisions explicitly relating to fatigue deal only with load-induced fatigue.

6.6.1.2—Load-Induced Fatigue*6.6.1.2.1—Application*

The force effect considered for the fatigue design of a steel bridge detail shall be the live load stress range. For flexural members with shear connectors provided throughout their entire length, and with concrete deck reinforcement satisfying the provisions of Article 6.10.1.7, live load stresses and stress ranges for fatigue design may be computed using the short-term composite section assuming the concrete deck to be effective for both positive and negative flexure.

Residual stresses shall not be considered in investigating fatigue.

These provisions shall be applied only to details subjected to a net applied tensile stress. In regions where the unfactored permanent loads produce compression, fatigue shall be considered only if the compressive stress is less than the maximum live load tensile stress caused by the Fatigue I load combination specified in Table 3.4.1-1.

C6.6.1.2.1

Concrete can provide significant resistance to tensile stress at service load levels. Recognizing this behavior will have a significantly beneficial effect on the computation of fatigue stress ranges in top flanges in regions of stress reversal and in regions of negative flexure. By utilizing shear connectors in these regions to ensure composite action in combination with the required one percent longitudinal reinforcement wherever the longitudinal tensile stress in the concrete deck exceeds the factored modulus of rupture of the concrete, crack length and width can be controlled so that full-depth cracks should not occur. When a crack does occur, the stress in the longitudinal reinforcement increases until the crack is arrested. Ultimately, the cracked concrete and the reinforcement reach equilibrium. Thus, the concrete deck may contain a small number of staggered cracks at any given section. Properly placed longitudinal reinforcement prevents coalescence of these cracks.

It has been shown that the level of total applied stress is insignificant for a welded steel detail. Residual stresses due to welding are implicitly included through the specification of stress range as the sole dominant stress parameter for fatigue design. This same concept of considering only stress range has been applied to rolled, bolted, and riveted details where far different residual stress fields exist. The application to nonwelded details is conservative. A complete stress range cycle may include both a tensile and compressive component. Only the live load plus dynamic load allowance effects need be considered when computing a stress range cycle; permanent loads do not contribute to the stress range. Tensile stresses propagate fatigue cracks. Material subjected to a cyclical loading at or near an initial flaw will be subject to a fully effective stress cycle in tension, even in cases of stress reversal, because the superposition of the tensile residual stress elevates the entire cycle into the tensile stress region.

Fatigue design criteria need only be considered for components or details subject to effective stress cycles in tension and/or stress reversal. If a component or detail is subject to stress reversal, fatigue is to be considered no matter how small the tension component of the stress cycle is since a flaw in the tensile residual stress zone could still be propagated by the small tensile component of stress. The decision on whether or not a tensile stress could exist is based on the Fatigue I Load Combination because this is the largest stress range a detail is expected to experience often enough to propagate a crack. When the tensile component of the stress range cycle resulting from this load combination exceeds the compressive stress due to the unfactored permanent loads, there is a net tensile stress in the component or at the detail under consideration, and therefore, fatigue must be considered. If the tensile component of the stress range does not exceed the

compressive stress due to the unfactored permanent loads there is no net tensile stress. In this case, the stress cycle is compression—compression and a fatigue crack will not propagate beyond a heat-affected zone.

Cross-frames and diaphragms connecting adjacent girders are stressed when one girder deflects with respect to the adjacent girder connected by the diaphragm or cross-frame. The sense of stress is reversed when the vehicle is positioned over the adjacent girder. Since it is the total stress range that produces fatigue, the effects of trucks in different transverse positions usually creates the largest stress range in these bracing members. To cause one cycle of the stress range so computed requires two vehicles to traverse the bridge in separate transverse positions with one vehicle leading the other. For cases where the force effects in these members are available from an analysis, such as in horizontally curved or sharply skewed bridges, it may be desirable in some instances to check fatigue-sensitive details on a bracing member subjected to a net applied tensile stress determined as specified herein. In lieu of more specific owner supplied guidance, it is recommended that one cycle of stress be taken as 75 percent of the stress range in the member determined by the passage of the factored fatigue load in the two different transverse positions just described. The factor of 0.75 is distinct from the load factor specified for the applicable fatigue load combination in Table 3.4.1-1; i.e., both factors may be applied simultaneously. The reduction is intended to approximate the low probability of two vehicles being located in the critical relative positions, such as outside of a striped lane, over millions of cycles. However, in no case should the calculated range of stress be less than the stress range caused by loading of only one lane. There is no provision in this recommended procedure to account for the need for two trucks to cause a single cycle of stress. For cases where the nominal fatigue resistance is calculated based on a finite life, the Engineer may wish to consider a reduction in the number of cycles whenever two trucks are required to cause a single cycle of stress.

6.6.1.2.2—Design Criteria

For load-induced fatigue considerations, each detail shall satisfy:

$$\gamma(\Delta f) \leq (\Delta F)_n \quad (6.6.1.2.2-1)$$

where:

- γ = load factor specified in Table 3.4.1-1 for the fatigue load combination
- (Δf) = force effect, live load stress range due to the passage of the fatigue load as specified in Article 3.6.1.4 (ksi)
- $(\Delta F)_n$ = nominal fatigue resistance as specified in Article 6.6.1.2.5 (ksi)

6.6.1.2.3—Detail Categories

Components and details shall be designed to satisfy the requirements of their respective detail categories summarized in Table 6.6.1.2.3-1. Where bolt holes are

C6.6.1.2.2

Eq. 6.6.1.2.2-1 may be developed by rewriting Eq. 1.3.2.1-1 in terms of fatigue load and resistance parameters:

$$\eta\gamma(\Delta f) \leq \phi(\Delta F)_n \quad (C6.6.1.2.2-1)$$

but for the fatigue limit state,

$$\begin{aligned} \eta &= 1.0 \\ \phi &= 1.0 \end{aligned}$$

C6.6.1.2.3

Components and details susceptible to load-induced fatigue cracking have been grouped into eight categories, called detail categories, by fatigue resistance.

depicted in Table 6.6.1.2.3-1, their fabrication shall conform to the provisions of Article 11.4.8.5 of the *AASHTO LRFD Bridge Construction Specifications*. Where permitted for use, unless specific information is available to the contrary, bolt holes in cross-frame, diaphragm, and lateral bracing members and their connection plates shall be assumed for design to be punched full size.

Except as specified herein for fracture critical members, where the projected 75-year single lane Average Daily Truck Traffic ($ADTT$)_{SL} is less than or equal to that specified in Table 6.6.1.2.3-2 for the component or detail under consideration, that component or detail should be designed for finite life using the Fatigue II load combination specified in Table 3.4.1-1. Otherwise, the component or detail shall be designed for infinite life using the Fatigue I load combination. The single-lane Average Daily Truck Traffic ($ADTT$)_{SL} shall be computed as specified in Article 3.6.1.4.2.

For components and details on fracture-critical members, the Fatigue I load combination specified in Table 3.4.1-1 should be used in combination with the nominal fatigue resistance for infinite life specified in Article 6.6.1.2.5.

Orthotropic deck components and details shall be designed to satisfy the requirements of their respective detail categories summarized in Table 6.6.1.2.3-1 for the chosen design level shown in the table and as specified in Article 9.8.3.4.

Experience indicates that in the design process the fatigue considerations for Detail Categories A through B' rarely, if ever, govern. Nevertheless, Detail Categories A through B' have been included in Table 6.6.1.2.3-1 for completeness. Investigation of components and details with a fatigue resistance based on Detail Categories A through B' may be appropriate in unusual design cases.

Table 6.6.1.2.3-1 illustrates many common details found in bridge construction and identifies potential crack initiation points for each detail. In Table 6.6.1.2.3-1, "Longitudinal" signifies that the direction of applied stress is parallel to the longitudinal axis of the detail. "Transverse" signifies that the direction of applied stress is perpendicular to the longitudinal axis of the detail.

Category F for allowable shear stress range on the throat of a fillet weld has been eliminated from Table 6.6.1.2.3-1. When fillet welds are properly sized for strength considerations, Category F should not govern. Fatigue will be governed by cracking in the base metal at the weld toe and not by shear on the throat of the weld. Research on end-bolted cover plates is discussed in Wattar et al. (1985).

Where the design stress range calculated using the Fatigue I load combination is less than $(\Delta F)_{TH}$, the detail will theoretically provide infinite life. Except for Categories E and E', for higher traffic volumes, the design will most often be governed by the infinite life check. Table 6.6.1.2.3-2 shows for each detail category the values of ($ADTT$)_{SL} above which the infinite life check governs, assuming a 75-yr design life and one stress range cycle per truck.

The values in the second column of Table 6.6.1.2.3-2 were computed as follows:

$$75_Year(ADTT)_{SL} = \frac{A}{\left[\frac{(\Delta F)_{TH}}{2}\right]^3 (365)(75)(n)} \quad (C6.6.1.2.3-1)$$

using the values for A and $(\Delta F)_{TH}$ specified in Tables 6.6.1.2.5-1 and 6.6.1.2.5-3, respectively, a fatigue design life of 75 yr and a number of stress range cycles per truck passage, n , equal to one. These values were rounded up to the nearest five trucks per day. That is, the indicated values were determined by equating infinite life and finite life resistances with due regard to the difference in load factors used with the Fatigue I and Fatigue II load combinations. For other values of n , the values in Table 6.6.1.2.3-2 should be modified by dividing by the appropriate value of n taken from Table 6.6.1.2.5-2. For other values of the fatigue design life, the values in Table 6.6.1.2.3-2 should be modified by multiplying the values by the ratio of 75 divided by the fatigue life sought in years.

The procedures for load-induced fatigue are followed for orthotropic deck design. Although the local structural stress range for certain fatigue details can be caused by distortion of the deck plate, ribs, and floorbeams, research has demonstrated that load-induced fatigue analysis produces a reliable assessment of fatigue performance.

Considering the increased γ_{LL} and cycles per truck passage (n) in orthotropic decks, the 75-yr $ADTT_{SL}$ equivalent to infinite life (trucks per day) results in 870 for

deck plate details and 4350 for all other details, based on Category C. Thus, finite life design may produce more economical designs on lower-volume roadways.

Table 6.6.1.2.3-1—Detail Categories for Load-Induced Fatigue

Description	Category	Constant A (ksi ³)	Threshold $(\Delta F)_{TH}$ ksi	Potential Crack Initiation Point	Illustrative Examples
Section 1—Plain Material away from Any Welding					
1.1 Base metal, except noncoated weathering steel, with rolled or cleaned surfaces. Flame-cut edges with surface roughness value of 1,000 μ-in. or less, but without re-entrant corners.	A	250×10^8	24	Away from all welds or structural connections	
1.2 Noncoated weathering steel base metal with rolled or cleaned surfaces designed and detailed in accordance with FHWA (1989). Flame-cut edges with surface roughness value of 1,000 μ-in. or less, but without re-entrant corners.	B	120×10^8	16	Away from all welds or structural connections	
1.3 Member with re-entrant corners at copes, cuts, block-outs or other geometrical discontinuities made to the requirements of AASHTO/AWS D1.5, except weld access holes.	C	44×10^8	10	At any external edge	
1.4 Rolled cross sections with weld access holes made to the requirements of AASHTO/AWS D1.5, Article 3.2.4.	C	44×10^8	10	In the base metal at the re-entrant corner of the weld access hole	
1.5 Open holes in members (Brown et al., 2007).	D	22×10^8	7	In the net section originating at the side of the hole	
Section 2—Connected Material in Mechanically Fastened Joints					
2.1 Base metal at the gross section of high-strength bolted joints designed as slip-critical connections with pretensioned high-strength bolts installed in holes drilled full size or subpunched and reamed to size—e.g., bolted flange and web splices and bolted stiffeners. (Note: see Condition 2.3 for bolt holes punched full size; see Condition 2.5 for bolted angle or tee section member connections to gusset or connection plates.)	B	120×10^8	16	Through the gross section near the hole	

continued on next page

Table 6.6.1.2.3-1 (continued)—Detail Categories for Load-Induced Fatigue

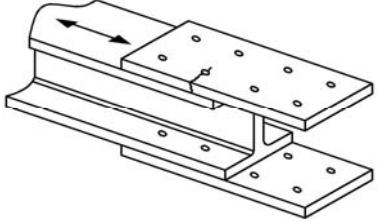
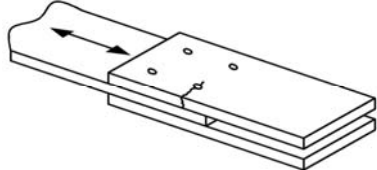
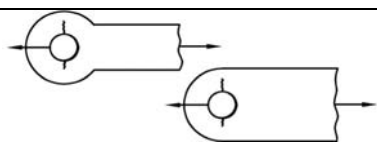
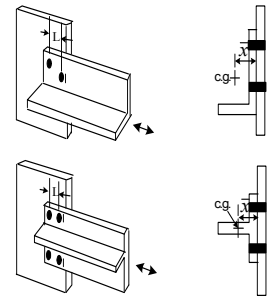
Description	Category	Constant A (ksi ³)	Threshold $(\Delta F)_{TH}$ ksi	Potential Crack Initiation Point	Illustrative Examples
Section 2—Connected Material in Mechanically Fastened Joints (continued)					
2.2 Base metal at the net section of high-strength bolted joints designed as bearing-type connections but fabricated and installed to all requirements for slip-critical connections with pretensioned high-strength bolts installed in holes drilled full size or subpunched and reamed to size. (Note: see Condition 2.3 for bolt holes punched full size; see Condition 2.5 for bolted angle or tee section member connections to gusset or connection plates.)	B	120×10^8	16	In the net section originating at the side of the hole	
2.3 Base metal at the net section of all bolted connections in hot dipped galvanized members (Huhn and Valtinat, 2004); base metal at the appropriate section defined in Condition 2.1 or 2.2, as applicable, of high-strength bolted joints with pretensioned bolts installed in holes punched full size (Brown et al., 2007); and base metal at the net section of other mechanically fastened joints, except for eyebars and pin plates, e.g., joints using ASTM A307 bolts or non-pretensioned high-strength bolts. (Note: see Condition 2.5 for bolted angle or tee section member connections to gusset or connection plates).	D	22×10^8	7	In the net section originating at the side of the hole or through the gross section near the hole, as applicable	
2.4 Base metal at the net section of eyebar heads or pin plates (Note: for base metal in the shank of eyebars or through the gross section of pin plates, see Condition 1.1 or 1.2, as applicable.)	E	11×10^8	4.5	In the net section originating at the side of the hole	
2.5 Base metal in angle or tee section members connected to a gusset or connection plate with high-strength bolted slip-critical connections. The fatigue stress range shall be calculated on the effective net area of the member, $A_e = UA_g$, in which $U=(1-\bar{x}/L)$ and where A_g is the gross area of the member. \bar{x} is the distance from the centroid of the member to the surface of the gusset or connection plate and L is the out-to-out distance between the bolts in the connection parallel to the line of force. The effect of the moment due to the eccentricities in the connection shall be ignored in computing the stress range (McDonald and Frank, 2009).	See applicable Category above	See applicable Constant above	See applicable Threshold above	Through the gross section near the hole, or in the net section originating at the side of the hole, as applicable	

continued on next page

Table 6.6.1.2.3-1 (continued)—Detail Categories for Load-Induced Fatigue

Description	Category	Constant A (ksi ³)	Threshold $(\Delta F)_{TH}$ ksi	Potential Crack Initiation Point	Illustrative Examples
2.5 (continued) The fatigue category shall be taken as that specified for Condition 2.1. For all other types of bolted connections, replace A_g with the net area of the member, A_n , in computing the effective net area according to the preceding equation and use the appropriate fatigue category for that connection type specified for Condition 2.2 or 2.3, as applicable.					
Section 3—Welded Joints Joining Components of Built-Up Members					
3.1 Base metal and weld metal in members without attachments built up of plates or shapes connected by continuous longitudinal complete joint penetration groove welds back-gouged and welded from the second side, or by continuous fillet welds parallel to the direction of applied stress.	B	120×10^8	16	From surface or internal discontinuities in the weld away from the end of the weld	
3.2 Base metal and weld metal in members without attachments built up of plates or shapes connected by continuous longitudinal complete joint penetration groove welds with backing bars not removed, or by continuous partial joint penetration groove welds parallel to the direction of applied stress.	B'	61×10^8	12	From surface or internal discontinuities in the weld, including weld attaching backing bars	
3.3 Base metal and weld metal at the termination of longitudinal welds at weld access holes made to the requirements of AASHTO/AWS D1.5, Article 3.2.4 in built-up members. (Note: does not include the flange butt splice).	D	22×10^8	7	From the weld termination into the web or flange	
3.4 Base metal and weld metal in partial length welded cover plates connected by continuous fillet welds parallel to the direction of applied stress.	B	120×10^8	16	From surface or internal discontinuities in the weld away from the end of the weld	

continued on next page

Table 6.6.1.2.3-1 (continued)—Detail Categories for Load-Induced Fatigue

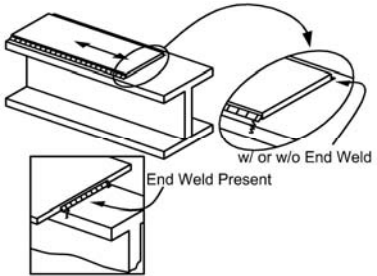
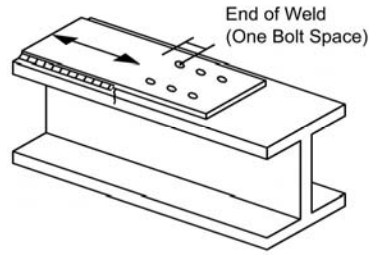
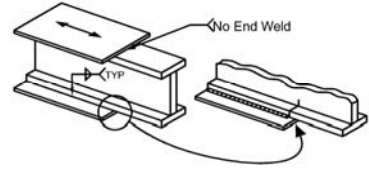
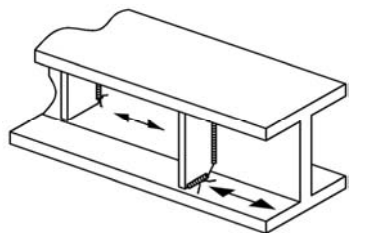
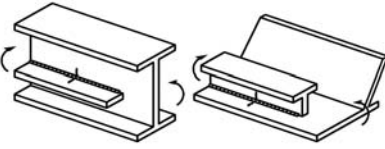
Description	Category	Constant A (ksi ³)	Threshold $(\Delta f)_{TH}$ ksi	Potential Crack Initiation Point	Illustrative Examples
Section 3—Welded Joints Joining Components of Built-Up Members (continued)					
3.5 Base metal at the termination of partial length welded cover plates having square or tapered ends that are narrower than the flange, with or without welds across the ends, or cover plates that are wider than the flange with welds across the ends: Flange thickness ≤ 0.8 in. Flange thickness > 0.8 in.	E E'	11×10^8 3.9×10^8	4.5 2.6	In the flange at the toe of the end weld or in the flange at the termination of the longitudinal weld or in the edge of the flange with wide cover plates	
3.6 Base metal at the termination of partial length welded cover plates with slip-critical bolted end connections satisfying the requirements of Article 6.10.12.2.3.	B	120×10^8	16	In the flange at the termination of the longitudinal weld	
3.7 Base metal at the termination of partial length welded cover plates that are wider than the flange and without welds across the ends.	E'	3.9×10^8	2.6	In the edge of the flange at the end of the cover plate weld	
Section 4—Welded Stiffener Connections					
4.1 Base metal at the toe of transverse stiffener-to-flange fillet welds and transverse stiffener-to-web fillet welds. (Note: includes similar welds on bearing stiffeners and connection plates).	C'	44×10^8	12	Initiating from the geometrical discontinuity at the toe of the fillet weld extending into the base metal	
4.2 Base metal and weld metal in longitudinal web or longitudinal box-flange stiffeners connected by continuous fillet welds parallel to the direction of applied stress.	B	120×10^8	16	From the surface or internal discontinuities in the weld away from the end of the weld	

continued on next page

Table 6.6.1.2.3-1 (continued)—Detail Categories for Load-Induced Fatigue

Description	Category	Constant A (ksi ³)	Threshold $(\Delta f)_{TH}$ ksi	Potential Crack Initiation Point	Illustrative Examples
Section 4—Welded Stiffener Connections (continued)					
<p>4.3 Base metal at the termination of longitudinal stiffener-to-web or longitudinal stiffener-to-box flange welds:</p> <p>With the stiffener attached by fillet welds and with no transition radius provided at the termination:</p> <p>Stiffener thickness < 1.0 in.</p> <p>Stiffener thickness ≥ 1.0 in.</p> <p>With the stiffener attached by welds and with a transition radius R provided at the termination with the weld termination ground smooth:</p> <p>$R \geq 24$ in.</p> <p>24 in. > $R \geq 6$ in.</p> <p>6 in. > $R \geq 2$ in.</p> <p>2 in. > R</p>	<p>E</p> <p>E'</p> <p>B</p> <p>C</p> <p>D</p> <p>E</p>	<p>11×10^8</p> <p>3.9×10^8</p> <p>120×10^8</p> <p>44×10^8</p> <p>22×10^8</p> <p>11×10^8</p>	<p>4.5</p> <p>2.6</p> <p>16</p> <p>10</p> <p>7</p> <p>4.5</p>	<p>In the primary member at the end of the weld at the weld toe</p> <p>In the primary member near the point of tangency of the radius</p>	
Section 5—Welded Joints Transverse to the Direction of Primary Stress					
<p>5.1 Base metal and weld metal in or adjacent to complete joint penetration groove welded butt splices, with weld soundness established by NDT and with welds ground smooth and flush parallel to the direction of stress. Transitions in thickness or width shall be made on a slope no greater than 1:2.5 (see also Figure 6.13.6.2-1).</p> <p>$F_y < 100$ ksi</p> <p>$F_y \geq 100$ ksi</p>	<p>B</p> <p>B'</p>	<p>120×10^8</p> <p>61×10^8</p>	<p>16</p> <p>12</p>	<p>From internal discontinuities in the filler metal or along the fusion boundary or at the start of the transition</p>	
<p>5.2 Base metal and weld metal in or adjacent to complete joint penetration groove welded butt splices, with weld soundness established by NDT and with welds ground parallel to the direction of stress at transitions in width made on a radius of not less than 2 ft with the point of tangency at the end of the groove weld (see also Figure 6.13.6.2-1).</p>	<p>B</p>	<p>120×10^8</p>	<p>16</p>	<p>From internal discontinuities in the filler metal or discontinuities along the fusion boundary</p>	

continued on next page

Table 6.6.1.2.3-1 (continued)—Detail Categories for Load-Induced Fatigue

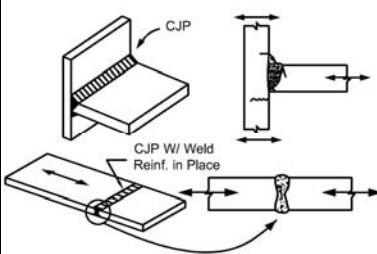
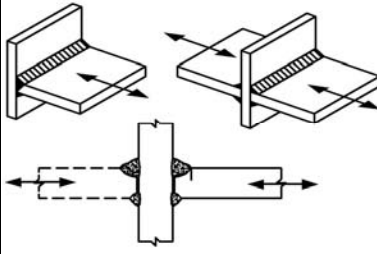
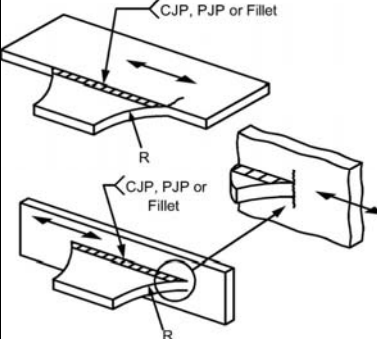
Description	Category	Constant A (ksi ³)	Threshold $(\Delta f)_{TH}$ ksi	Potential Crack Initiation Point	Illustrative Examples
5.3 Base metal and weld metal in or adjacent to the toe of complete joint penetration groove welded T or corner joints, or in complete joint penetration groove welded butt splices, with or without transitions in thickness having slopes no greater than 1:2.5 when weld reinforcement is not removed. (Note: cracking in the flange of the "T" may occur due to out-of-plane bending stresses induced by the stem).	C	44×10^8	10	From the surface discontinuity at the toe of the weld extending into the base metal or along the fusion boundary	
5.4 Base metal and weld metal at details where loaded discontinuous plate elements are connected with a pair of fillet welds or partial joint penetration groove welds on opposite sides of the plate normal to the direction of primary stress.	C as adjusted in Eq. 6.6.1.2.5-4	44×10^8	10	Initiating from the geometrical discontinuity at the toe of the weld extending into the base metal or initiating at the weld root subject to tension extending up and then out through the weld	
Section 6—Transversely Loaded Welded Attachments					
6.1 Base metal in a longitudinally loaded component at a transversely loaded detail (e.g. a lateral connection plate) attached by a weld parallel to the direction of primary stress and incorporating a transition radius R with the weld termination ground smooth.				Near point of tangency of the radius at the edge of the longitudinally loaded component or at the toe of the weld at the weld termination if not ground smooth	
$R \geq 24$ in.	B	120×10^8	16		
24 in. $> R \geq 6$ in.	C	44×10^8	10		
6 in. $> R \geq 2$ in.	D	22×10^8	7		
2 in. $> R$	E	11×10^8	4.5		
For any transition radius with the weld termination not ground smooth (Note: Condition 6.2, 6.3 or 6.4, as applicable, shall also be checked.)	E	11×10^8	4.5		

continued on next page

Table 6.6.1.2.3-1 (continued)—Detail Categories for Load-Induced Fatigue

Description	Category	Constant A (ksi ³)	Threshold $(\Delta f)_{TH}$ ksi	Potential Crack Initiation Point	Illustrative Examples
Section 6—Transversely Loaded Welded Attachments (continued)					
<p>6.2 Base metal in a transversely loaded detail (e.g. a lateral connection plate) attached to a longitudinally loaded component of equal thickness by a complete joint penetration groove weld parallel to the direction of primary stress and incorporating a transition radius R, with weld soundness established by NDT and with the weld termination ground smooth:</p> <p>With the weld reinforcement removed:</p> <p style="padding-left: 20px;">$R \geq 24$ in.</p> <p style="padding-left: 20px;">24 in. $> R \geq 6$ in.</p> <p style="padding-left: 20px;">6 in. $> R \geq 2$ in.</p> <p style="padding-left: 20px;">2 in. $> R$</p> <p>With the weld reinforcement not removed:</p> <p style="padding-left: 20px;">$R \geq 24$ in.</p> <p style="padding-left: 20px;">24 in. $> R \geq 6$ in.</p> <p style="padding-left: 20px;">6 in. $> R \geq 2$ in.</p> <p style="padding-left: 20px;">2 in. $> R$</p> <p>(Note: Condition 6.1 shall also be checked.)</p>					
<p>6.3 Base metal in a transversely loaded detail (e.g. a lateral connection plate) attached to a longitudinally loaded component of unequal thickness by a complete joint penetration groove weld parallel to the direction of primary stress and incorporating a weld transition radius R, with weld soundness established by NDT and with the weld termination ground smooth:</p> <p>With the weld reinforcement removed:</p> <p style="padding-left: 20px;">$R \geq 2$ in.</p> <p style="padding-left: 20px;">$R < 2$ in.</p> <p>For any weld transition radius with the weld reinforcement not removed (Note: Condition 6.1 shall also be checked.)</p>				<p>At the toe of the weld along the edge of the thinner plate</p> <p>In the weld termination of small radius weld transitions</p> <p>At the toe of the weld along the edge of the thinner plate</p>	

continued on next page

Table 6.6.1.2.3-1 (continued)—Detail Categories for Load-Induced Fatigue

Description	Category	Constant A (ksi ³)	Threshold $(\Delta f)_{TH}$ ksi	Potential Crack Initiation Point	Illustrative Examples
Section 6—Transversely Loaded Welded Attachments (continued)					
6.4 Base metal in a transversely loaded detail (e.g. a lateral connection plate) attached to a longitudinally loaded component by a fillet weld or a partial joint penetration groove weld, with the weld parallel to the direction of primary stress (Note: Condition 6.1 shall also be checked.)	See Condition 5.4				
Section 7—Longitudinally Loaded Welded Attachments					
7.1 Base metal in a longitudinally loaded component at a detail with a length L in the direction of the primary stress and a thickness t attached by groove or fillet welds parallel or transverse to the direction of primary stress where the detail incorporates no transition radius: $L < 2$ in. 2 in. $\leq L \leq 12t$ or 4 in. $L > 12t$ or 4 in. $t < 1.0$ in. $t \geq 1.0$ in. (Note: see Condition 7.2 for welded angle or tee section member connections to gusset or connection plates.)	C D E E'	44×10^8 22×10^8 11×10^8 3.9×10^8	10 7 4.5 2.6	In the primary member at the end of the weld at the weld toe	
7.2 Base metal in angle or tee section members connected to a gusset or connection plate by longitudinal fillet welds along both sides of the connected element of the member cross-section. The fatigue stress range shall be calculated on the effective net area of the member, $A_e = UA_g$, in which $U = (1 - \bar{x}/L)$ and where A_g is the gross area of the member. \bar{x} is the distance from the centroid of the member to the surface of the gusset or connection plate and L is the maximum length of the longitudinal welds. The effect of the moment due to the eccentricities in the connection shall be ignored in computing the stress range (McDonald and Frank, 2009).	E	11×10^8	4.5	Toe of fillet welds in connected element	

continued on next page

Table 6.6.1.2.3-1 (continued)—Detail Categories for Load-Induced Fatigue

Description	Category	Constant A (ksi ³)	Threshold $(\Delta f)_{TH}$ ksi	Potential Crack Initiation Point	Illustrative Examples
Section 8—Miscellaneous					
8.1 Rib to Deck Weld—One-sided 80% (70% min) penetration weld with root gap ≤ 0.02 in. prior to welding Allowable Design Level 1, 2, or 3	C	44×10^8	10	See Figure	
8.2 Rib Splice (Welded)—Single groove butt weld with permanent backing bar left in place. Weld gap $>$ rib wall thickness Allowable Design Level 1, 2, or 3	D	22×10^8	7	See Figure	
8.3 Rib Splice (Bolted)—Base metal at gross section of high strength slip critical connection Allowable Design Level 1, 2, or 3	B	120×10^8	16	See Figure	
8.4 Deck Plate Splice (in Plane)—Transverse or Longitudinal single groove butt splice with permanent backing bar left in place Allowable Design Level 1, 2, or 3	D	22×10^8	7	See Figure	
8.5 Rib to FB Weld (Rib)—Rib wall at rib to FB weld (fillet or CJP) Allowable Design Level 1, 2, or 3	C	44×10^8	10	See Figure	

continued on next page

Table 6.6.1.2.3-1 (continued)—Detail Categories for Load-Induced Fatigue

Description	Category	Constant A (ksi ³)	Threshold $(\Delta f)_{TH}$ ksi	Potential Crack Initiation Point	Illustrative Examples
8.6 Rib to FB Weld (FB Web)—FB web at rib to FB weld (fillet, PJP, or CJP) Allowable Design Level 1 or 3	C (see Note 1)	44×10^8	10	See Figure	
8.7 FB Cutout—Base metal at edge with “smooth” flame cut finish as per AWS D1.5 Allowable Design Level 1 or 3	A	250×10^8	24	See Figure	
8.8 Rib Wall at Cutout—Rib wall at rib to FB weld (fillet, PJP, or CJP) Allowable Design Level 1 or 3	C	44×10^8	10	See Figure	
8.9 Rib to Deck Plate at FB Allowable Design Level 1 or 3	C	44×10^8	10	See Figure	
Note 1: Where stresses are dominated by in-plane component at fillet or PJP welds, Eq. 6.6.1.2.5-4 shall be considered. In this case, Δf should be calculated at the mid-thickness and the extrapolation procedure as per Article 9.8.3.4.3 need not be applied.					
Section 9—Miscellaneous					
9.1 Base metal at stud-type shear connectors attached by fillet or automatic stud welding Allowable Design Level 1 or 3		44×10^8	10	At the toe of the weld in the base metal	

continued on next page

Table 6.6.1.2.3-1 (continued)—Detail Categories for Load-Induced Fatigue

Description	Category	Constant A (ksi ³)	Threshold $(\Delta F)_{TH}$ ksi	Potential Crack Initiation Point	Illustrative Examples
Section 9—Miscellaneous (continued)					
9.2 Nonpretensioned high-strength bolts, common bolts, threaded anchor rods, and hanger rods with cut, ground, or rolled threads. Use the stress range acting on the tensile stress area due to live load plus prying action when applicable.				At the root of the threads extending into the tensile stress area	
(Fatigue II) Finite Life	E'	3.9×10^8	N/A		
(Fatigue I) Infinite Life	D	N/A	7		

Table 6.6.1.2.3-2—75-yr $(ADTT)_{SL}$ Equivalent to Infinite Life

Detail Category	75-yr $(ADTT)_{SL}$ Equivalent to Infinite Life (trucks per day)
A	530
B	860
B'	1035
C	1290
C'	745
D	1875
E	3530
E'	6485

[This page is intentionally left blank. —ed.]

[This page is intentionally left blank. —ed.]

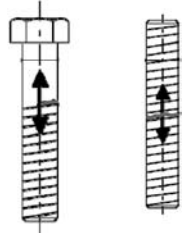
6.6.1.2.4—Detailing to Reduce Constraint

To the extent practical, welded structures shall be detailed to avoid conditions that create highly constrained joints and crack-like geometric discontinuities that are susceptible to constraint-induced fracture. Welds that are parallel to the primary stress but interrupted by intersecting members shall be detailed to allow a minimum gap of 1 in. between weld toes.

C6.6.1.2.4

The objective of this Article is to provide recommended detailing guidelines for common joints to avoid details susceptible to brittle fracture.

The form of brittle fracture being addressed has been termed “constraint-induced fracture” and can occur without any perceptible fatigue crack growth and, more importantly, without any warning. This type of failure was documented during the Hoan Bridge failure investigation by Wright, Kaufmann, and Fisher (2003) and Kaufmann, Connor, and Fisher (2004). Criteria have been developed to identify bridges and details susceptible to this failure mode as discussed in Mahmoud, Connor and Fisher (2005).

Intersecting welds should be avoided.

Attached elements parallel to the primary stress are sometimes interrupted when intersecting a full-depth transverse member. These elements are less susceptible to fracture and fatigue if the attachment parallel to the primary stress is continuous and the transverse attachment is discontinuous as shown in Figure C6.6.1.2.4-1. Also shown is the space between the weld of the transverse stiffener to the web and the weld of the longitudinal stiffener to the web required to reduce constraint.

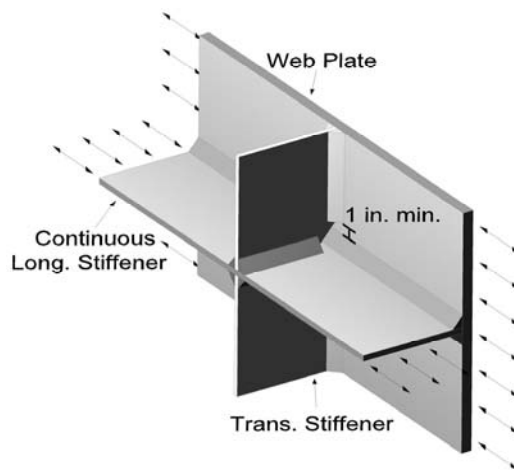

Figure C6.6.1.2.4-1—A Weld Detail where the Longitudinal Stiffener Is Continuous

6.6.1.2.5—Fatigue Resistance

Except as specified below, nominal fatigue resistance shall be taken as:

- For the Fatigue I load combination and infinite life:

$$(\Delta F)_n = (\Delta F)_{TH} \quad (6.6.1.2.5-1)$$
- For the Fatigue II load combination and finite life:

C6.6.1.2.5

The requirement on higher-traffic-volume bridges that the maximum stress range experienced by a detail be less than the constant-amplitude fatigue threshold provides a theoretically infinite fatigue life. This requirement is reflected in Eq. 6.6.1.2.5-1.

The fatigue resistance above the constant amplitude fatigue threshold, in terms of cycles, is inversely proportional to the cube of the stress range, e.g., if the stress range is reduced by a factor of 2, the fatigue life increases by a factor of 2³. This is reflected in

$$(\Delta F)_n = \left(\frac{A}{N} \right)^{\frac{1}{3}} \quad (6.6.1.2.5-2)$$

in which:

$$N = (365)(75)n(ADTT)_{SL} \quad (6.6.1.2.5-3)$$

where:

- A = constant taken from Table 6.6.1.2.5-1 (ksi³)
 n = number of stress range cycles per truck passage taken from Table 6.6.1.2.5-2
 $(ADTT)_{SL}$ = single-lane ADTT as specified in Article 3.6.1.4
 $(\Delta F)_{TH}$ = constant-amplitude fatigue threshold taken from Table 6.6.1.2.5-3 (ksi)

The nominal fatigue resistance for base metal and weld metal at details where loaded discontinuous plate elements are connected with a pair of fillet welds or partial joint penetration groove welds on opposite sides of the plate normal to the direction of primary stress shall be taken as:

$$(\Delta F)_n = (\Delta F)_n^c \left[\frac{0.65 - 0.59 \left(\frac{2a}{t_p} \right) + 0.72 \left(\frac{w}{t_p} \right)}{t_p^{0.167}} \right] \leq (\Delta F)_n^c \quad (6.6.1.2.5-4)$$

where:

- $(\Delta F)_n^c$ = nominal fatigue resistance for Detail Category C (ksi)

Eq. 6.6.1.2.5-2. Orthotropic deck details that are connected to the deck plate (e.g., the rib-to-deck weld) are subjected to cycling from direct individual wheel loads. Thus, the passage of one design truck results in five fatigue load cycles as each axle produces one load cycle. The force effect (Δf) can be conservatively taken as the worst case from the five wheels or by application of Miner's Rule to determine the effective stress range from the group of wheels.

In the AASHTO 2002 *Standard Specifications*, the constant amplitude fatigue threshold is termed the allowable fatigue stress range for more than 2 million cycles on a redundant load path structure.

The fatigue design life has been considered to be 75 years in the overall development of the Specifications. If a fatigue design life other than 75 years is sought, a number other than 75 may be inserted in the equation for N .

Figure C6.6.1.2.5-1 is a graphical representation of the nominal fatigue resistance for Categories A through E'.

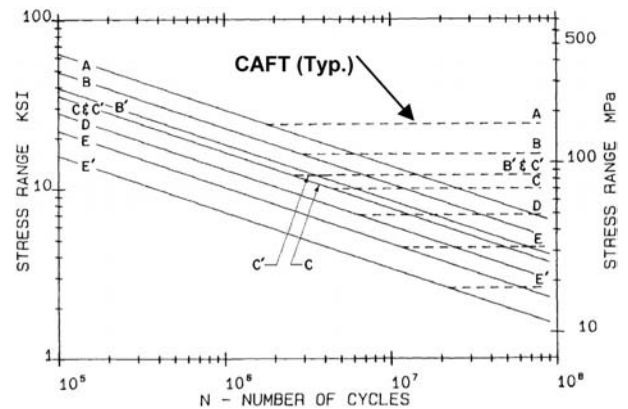

Figure C6.6.1.2.5-1—Stress Range Versus Number of Cycles

Eq. 6.6.1.2.5-4 accounts for the potential of a crack initiating from the weld root and includes the effects of weld penetration. Therefore, Eq. 6.6.1.2.5-4 is also applicable to partial joint penetration groove welds, as shown in Figure C6.6.1.2.5-2.

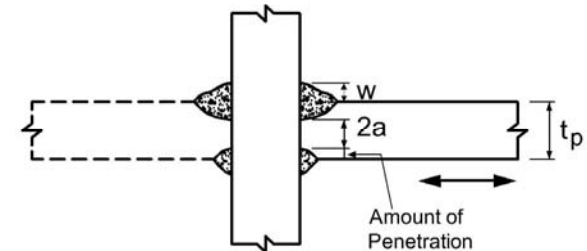

Figure C6.6.1.2.5-2—Loaded Discontinuous Plate Element Connected by a Pair of Partial Joint Penetration Groove Welds

- $2a$ = length of the non-welded root face in the direction of the thickness of the loaded plate (in.) For fillet welded connections, the quantity $(2a/t_p)$ shall be taken equal to 1.0.
 t_p = thickness of loaded plate (in.)
 w = leg size of the reinforcement or contour fillet, if any, in the direction of the thickness of the loaded plate (in.)

The effect of any weld penetration may be conservatively ignored in the calculation of $(\Delta F)_n$ from Eq. 6.6.1.2.5-4 by taking the quantity $(2a/t_p)$ equal to 1.0. The nominal fatigue resistance based on the crack initiating from the weld root in Eq. 6.6.1.2.5-4 is limited to the nominal fatigue resistance for Detail Category C, which assumes crack initiation from the weld toe. The development of Eq. 6.6.1.2.5-4 is discussed in Frank and Fisher (1979).

In the AASHTO 2002 *Standard Specifications*, allowable stress ranges are specified for both redundant and nonredundant members. The allowables for nonredundant members are arbitrarily specified as 80 percent of those for redundant members due to the more severe consequences of failure of a nonredundant member. However, greater fracture toughness is also specified for nonredundant members. In combination, the reduction in allowable stress range and the greater fracture toughness constitute an unnecessary double penalty for nonredundant members. The requirement for greater fracture toughness has been maintained in these Specifications. Therefore, the allowable stress ranges represented by Eqs. 6.6.1.2.5-1 and 6.6.1.2.5-2 are applicable to both redundant and nonredundant members.

Table 6.6.1.2.5-1—Detail Category Constant, A

Detail Category	Constant, A times 10^8 (ksi ³)
A	250.0
B	120.0
B'	61.0
C	44.0
C'	44.0
D	22.0
E	11.0
E'	3.9
M 164 (A325) Bolts in Axial Tension	17.1
M 253 (A490) Bolts in Axial Tension	31.5

Table 6.6.1.2.5-2—Cycles per Truck Passage, n

Longitudinal Members	Span Length	
	>40.0 ft	≤40.0 ft
Simple Span Girders	1.0	2.0
Continuous Girders		
1) near interior support	1.5	2.0
2) elsewhere	1.0	2.0
Cantilever Girders	5.0	
Orthotropic Deck Plate Connections Subjected to Wheel Load Cycling	5.0	
Trusses	1.0	
Transverse Members	Spacing	
	> 20.0 ft	≤20.0 ft
	1.0	2.0

Table 6.6.1.2.5-3—Constant-Amplitude Fatigue Thresholds

Detail Category	Threshold (ksi)
A	24.0
B	16.0
B'	12.0
C	10.0
C'	12.0
D	7.0
E	4.5
E'	2.6
M 164 (A 325) Bolts in Axial Tension	31.0
M 253 (A 490) Bolts in Axial Tension	38.0

6.6.1.3—Distortion-Induced Fatigue

Load paths that are sufficient to transmit all intended and unintended forces shall be provided by connecting all transverse members to appropriate components comprising the cross-section of the longitudinal member. The load paths shall be provided by attaching the various components through either welding or bolting.

To control web buckling and elastic flexing of the web, the provision of Article 6.10.5.3 shall be satisfied.

For the purpose of determining the stress-range cycles per truck passage for continuous spans, a distance equal to one-tenth the span on each side of an interior support should be considered to be near the support.

The number of stress-range cycles per passage is taken as 5.0 for cantilever girders because this type of bridge is susceptible to large vibrations, which cause additional cycles after the truck has left the bridge (Moses et al., 1987; Schilling, 1990).

Orthotropic deck details that are connected to the deck plate (e.g., the rib-to-deck weld) are subjected to cycling from direct individual wheel loads. Thus, the passage of one design truck results in five fatigue load cycles as each axle produces one load cycle. The force effect (Δf) can be conservatively taken as the worst case from the five wheels or by application of Miner's Rule to determine the effective stress range from the group of wheels.

C6.6.1.3

When proper detailing practices are not followed, fatigue cracking has been found to occur due to strains not normally computed in the design process. This type of fatigue cracking is called distortion-induced fatigue. Distortion-induced fatigue often occurs in the web near a flange at a welded connection plate for a cross-frame where a rigid load path has not been provided to adequately transmit the force in the transverse member from the web to the flange.

6.6.1.3.1—Transverse Connection Plates

Except as specified herein, connection plates shall be welded or bolted to both the compression and tension flanges of the cross-section where:

- Connecting diaphragms or cross-frames are attached to transverse connection plates or to transverse stiffeners functioning as connection plates,
- Internal or external diaphragms or cross-frames are attached to transverse connection plates or to transverse stiffeners functioning as connection plates, and
- Floorbeams or stringers are attached to transverse connection plates or to transverse stiffeners functioning as connection plates.

In the absence of better information, the welded or bolted connection should be designed to resist a 20.0-kip lateral load for straight, nonskewed bridges.

Where intermediate connecting diaphragms are used:

- On rolled beams in straight bridges with composite reinforced decks whose supports are normal or skewed not more than 10 degrees from normal and
- With the intermediate diaphragms placed in contiguous lines parallel to the supports.

less than full-depth end angles or connection plates may be bolted or welded to the beam web to connect the diaphragms. The end angles or plates shall be at least two-thirds the depth of the web. For bolted angles, a minimum gap of 3.0 in. shall be provided between the top and bottom bolt holes and each flange. Bolt spacing requirements specified in Article 6.13.2.6 shall be satisfied. For welded angles or plates, a minimum gap of 3.0 in. shall be provided between the top and bottom of the end-angle or plate welds and each flange; the heel and toe of the end angles or both sides of the connection plate, as applicable, shall be welded to the beam web. Welds shall not be placed along the top and bottom of the end angles or connection plates.

6.6.1.3.2—Lateral Connection Plates

If it is not practical to attach lateral connection plates to flanges, lateral connection plates on stiffened webs should be located a vertical distance not less than one-half the width of the flange above or below the flange. Lateral connection plates attached to unstiffened webs should be located at least 6.0 in. above or below the flange but not less than one-half of the width of the flange, as specified above.

C6.6.1.3.1

These rigid load paths are required to preclude the development of significant secondary stresses that could induce fatigue crack growth in either the longitudinal or the transverse member (Fisher et al., 1990).

These provisions appear in Article 10.20 of the AASHTO *Standard Specifications* “Diaphragms and Cross Frames” with no explanation as to the rationale for the requirements and no reference to distortion-induced fatigue.

These provisions apply to both diaphragms between longitudinal members and diaphragms internal to longitudinal members.

The 20.0-kip load represents a rule of thumb for straight, nonskewed bridges. For curved or skewed bridges, the diaphragm forces should be determined by analysis (Keating et al., 1990). It is noted that the stiffness of this connection is critical to help control relative displacement between the components. Hence, where possible, a welded connection is preferred as a bolted connection possessing sufficient stiffness may not be economical.

For box sections, webs are often joined to top flanges and cross-frame connection plates and transverse stiffeners are installed, and then these assemblies are attached to the common box flange. In order to weld the webs continuously to the box flange inside the box section, the details in this case should allow the welding head to clear the bottom of the connection plates and stiffeners. A similar detail may also be required for any intermediate transverse stiffeners that are to be attached to the box flange. Suggested details are shown in AASHTO/NSBA (2003). The Engineer is advised to consult with fabricators regarding the preferred approach for fabricating the box section and provide alternate details on the plans, if necessary.

C6.6.1.3.2

The specified minimum distance from the flange is intended to reduce the concentration of out-of-plane distortion in the web between the lateral connection plate and the flange to a tolerable magnitude. It also provides adequate electrode access and moves the connection plate closer to the neutral axis of the girder to reduce the impact of the weld termination on fatigue strength.

The ends of lateral bracing members on the lateral connection plate shall be kept a minimum of 4.0 in. from the web and any transverse stiffener.

Where stiffeners are used, lateral connection plates shall be centered on the stiffener, whether or not the plate is on the same side of the web as the stiffener. Where the lateral connection plate is on the same side of the web as the stiffener, the transverse stiffener at this location shall be discontinuous and attached to both flanges and the connection plate. The detailing of welded lateral connection plates shall also satisfy the provisions of Article 6.6.1.2.4.

This requirement reduces potential distortion-induced stresses in the gap between the web or stiffener and the lateral members on the lateral plate. These stresses may result from vibration of the lateral system. It also facilitates painting and field inspection.

The typical detail where the lateral connection plate is on the same side of the web as the stiffener is illustrated in Figure C6.6.1.3.2-1.

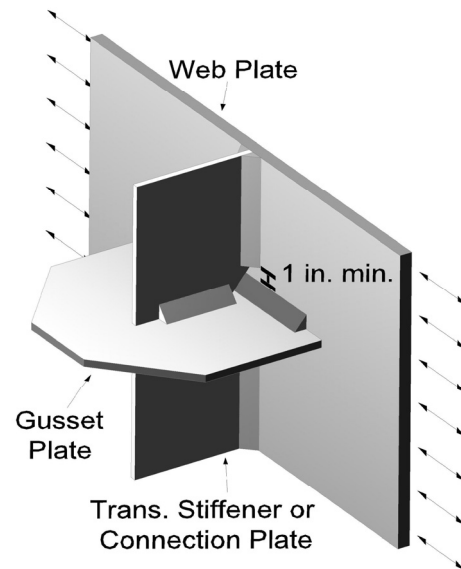

Figure C6.6.1.3.2-1—Typical Discontinuous Transverse Stiffener Detail at a Lateral Connection Plate

6.6.1.3.3—Orthotropic Decks

Detailing shall satisfy all requirements of Article 9.8.3.6.

C6.6.1.3.3

The purpose of this provision is to control distortion-induced fatigue of deck details subject to local secondary stresses due to out-of-plane bending.

6.6.2—Fracture

Except as specified herein, all primary longitudinal superstructure components and connections sustaining tensile stress due to Strength Load Combination I, as specified in Table 3.4.1-1, and transverse floorbeams subject to such stress, shall require mandatory Charpy V-notch testing. Other primary components and connections sustaining tensile stresses due to the Strength Load Combination I may require mandatory Charpy V-notch testing at the discretion of the Owner. All components and connections requiring Charpy V-notch testing shall be so designated on the contract plans.

Unless otherwise indicated on the contract plans, Charpy V-notch requirements shall not be considered mandatory for the following items:

- Splice plates and filler plates in bolted splices connected in double shear;

C6.6.2

The basis and philosophy for the supplemental impact requirements specified in the AASHTO Material Specifications is given in AISI (1975).

The specification of mandatory Charpy V-notch testing requirements for primary components and connections sustaining tensile stress under the specified load combination that are transverse to the primary longitudinal components, other than transverse floorbeams, is at the discretion of the Owner.

- Intermediate transverse web stiffeners not serving as connection plates;
- Bearings, sole plates, and masonry plates;
- Expansion dams; and
- Drainage material.

The appropriate temperature zone shall be determined from the applicable minimum service temperature specified in Table 6.6.2-1 and shall be designated in the contract documents.

Charpy V-notch impact energy requirements shall be in accordance with Table 6.6.2-2 for the appropriate temperature zone. The yield strength shall be taken as the value given in the certified Mill Test Report.

The Engineer shall have the responsibility for determining which, if any, component is a fracture-critical member (FCM). Unless a rigorous analysis with assumed hypothetical cracked components confirms the strength and stability of the hypothetically damaged structure, the location of all FCMs shall be clearly delineated on the contract plans. The contract documents shall require that FCMs shall be fabricated according to Section 12 of the *AASHTO/AWS D1.5M/D1.5 Bridge Welding Code*.

Any attachment having a length in the direction of the tension stress greater than 4.0 in. that is welded to a tension area of a component of a FCM shall be considered part of the tension component and shall be considered fracture-critical.

Table 6.6.2-1—Temperature Zone Designations for Charpy V-Notch Requirements

Minimum Service Temperature	Temperature Zone
0°F and above	1
-1°F to -30°F	2
-31°F to -60°F	3

The Charpy V-notch impact energy requirements are the same regardless of whether the component is welded or mechanically fastened, but vary depending on the type of steel, type of construction, and the applicable minimum service temperature. FCMs are subject to more stringent Charpy V-notch impact energy requirements than nonfracture-critical components.

Material for fracture-critical members or components designated FCM is to be tested in conformance with AASHTO T 243M/T 243 (ASTM A673/A673M) Frequency P, except for plates of AASHTO M 270M/M 270 (ASTM A709/A709M) Grade 36, 50, 50W, HPS 50W, and HPS 70W material, in which case specimens are to be selected as follows:

- As-rolled plates shall be sampled at each end of each plate-as-rolled.
- Normalized plates shall be sampled at one end of each plate-as-heat treated.
- Quenched and tempered plates shall be sampled at each end of each plate-as-heat treated.

AASHTO M 270M/M 270 (ASTM A709/A709M) Grade 36, 50, 50S, 50W, and HPS 50W material for components designated nonfracture-critical is to be tested in conformance with AASHTO T 243M/T 243 (ASTM A673/A673M), Frequency H. AASHTO M 270M/M 270 (ASTM A709/A709M) Grade HPS 70W and HPS 100W material for components designated nonfracture-critical is to be tested in conformance with AASHTO T 243M/T 243 (ASTM A673/A673M), Frequency P.

The criteria for a refined analysis used to demonstrate that part of a structure is not fracture-critical has not yet been codified. Therefore, the loading cases to be studied, location of potential cracks, degree to which the dynamic effects associated with a fracture are included in the analysis, and fineness of models and choice of element type should all be agreed upon by the Owner and the Engineer. The ability of a particular software product to adequately capture the complexity of the problem should also be considered and the choice of software should be mutually agreed upon by the Owner and the Engineer. Relief from the full factored loads associated with the Strength I Load Combination of Table 3.4.1-1 should be considered, as should the number of loaded design lanes versus the number of striped traffic lanes.

Table 6.6.2-2—CVN Impact Energy Requirements

Grade (Y.P./Y.S.)	Thickness (in.)	Fracture-Critical			Nonfracture-Critical			
		Min. Test Value Energy (ft-lbs.)	Zone 1 (ft-lbs. @ °F)	Zone 2 (ft-lbs. @ °F)	Zone 3 (ft-lbs. @ °F)	Zone 1 (ft-lbs. @ °F)	Zone 2 (ft-lbs. @ °F)	Zone 3 (ft-lbs. @ °F)
36	$t \leq 4$	20	25 @ 70	25 @ 40	25 @ 10	15 @ 70	15 @ 40	15 @ 10
50/50S/50W	$t \leq 2$	20	25 @ 70	25 @ 40	25 @ 10	15 @ 70	15 @ 40	15 @ 10
	$2 < t \leq 4$	24	30 @ 70	30 @ 40	30 @ 10	20 @ 70	20 @ 40	20 @ 10
HPS 50W	$t \leq 4$	24	30 @ 10	30 @ 10	30 @ 10	20 @ 10	20 @ 10	20 @ 10
HPS 70W	$t \leq 4$	28	35 @ -10	35 @ -10	35 @ -10	25 @ -10	25 @ -10	25 @ -10
HPS 100W	$t \leq 2-1/2$	28	35 @ -30	35 @ -30	35 @ -30	25 @ -30	25 @ -30	25 @ -30
	$2-1/2 < t \leq 4$	36	not permitted	not permitted	not permitted	35 @ -30	35 @ -30	35 @ -30

6.7—GENERAL DIMENSION AND DETAIL REQUIREMENTS

6.7.1—Effective Length of Span

Span lengths shall be taken as the distance between centers of bearings or other points of support.

6.7.2—Dead Load Camber

Steel structures should be cambered during fabrication to compensate for dead load deflection and vertical alignment.

Deflection due to steel weight and concrete weight shall be reported separately. Deflections due to future wearing surfaces or other loads not applied at the time of construction shall be reported separately.

Vertical camber shall be specified to account for the computed dead load deflection.

When staged construction is specified, the sequence of load application should be considered when determining the cambers.

Selective changes to component length, as appropriate, may be used for truss, arch, and cable-stayed systems to:

- Adjust the dead load deflection to comply with the final geometric position,
- Reduce or eliminate rib shortening, and
- Adjust the dead load moment diagram in indeterminate structures.

For straight skewed I-girder bridges and horizontally curved I-girder bridges with or without skewed supports, the contract documents should clearly state an intended erected position of the girders and the condition under which that position is to be theoretically achieved. The provisions of Article 2.5.2.6.1 related to bearing rotations shall also apply.

C6.7.2

As specified herein, staged construction refers to the situation in which superstructures are built in separate longitudinal units with a longitudinal joint, i.e., it does not refer to the deck pouring sequence.

The erection and cambering of straight skewed bridges and horizontally curved bridges with or without skewed supports is a more complex problem than generally considered. As of this writing (2005), there has been a trend toward more complex geometries and more flexible bridges combined with the use of higher strength steels. In some cases, failure to engineer the erection to achieve the intended final position of the girders, or to properly investigate potential outcomes when detailing to achieve an intended final position of the girders, has resulted in construction delays and claims. It is important that Engineers and Owners recognize the need for an engineered construction plan and the implied level of checking of shop drawings of girders and cross-frames or diaphragms, processing of RFIs or Requests for Information, and field inspection.

Intended erected positions of I-girders in straight skewed and horizontally curved bridges are defined herein as either:

- girder webs theoretically vertical or plumb, or
- girder webs out-of-plumb.

Three common conditions under which these intended erected positions can be theoretically achieved are defined herein as:

- the no-load condition,
- the steel dead load condition, or
- the full dead load condition.

The no-load condition refers to the condition where the girders are erected under a theoretically zero-stress condition, i.e., neglecting any stress due to the steel dead load acting between points of temporary support. The steel dead load condition refers to the condition after the erection of the steel is completed. The full dead load condition refers to the condition after the full noncomposite dead load, including the concrete deck, is applied.

In order for the girder webs of straight skewed I-girder bridges to end up theoretically plumb at the bearings under either the steel or full dead load condition, the cross-frames or diaphragms must be detailed for that condition in order to introduce the necessary twist into the girders during the erection. Although the cross-frames or diaphragms may have to be forced into position in this case, this can usually be accomplished in these types of bridges without inducing significant additional locked-in stresses in the girder flanges or the cross-frames or diaphragms. Alternatively, the girders may be erected plumb in the no-load condition if the resulting out-of-plumbness at the bearings and any potential errors in the horizontal roadway alignment under the full dead load condition are considered. In this case, the cross-frames or diaphragms are detailed to fit theoretically stress-free in the no-load condition. In either case, the rotation capacity of the bearings must either be able to accommodate the twist or the bearings must be installed in a manner to ensure that their rotation capacities are not exceeded.

For horizontally curved I-girder bridges with or without skewed supports, where the girders are erected plumb in the no-load condition, with the cross-frames or diaphragms detailed to fit in the no-load condition, the girder webs will not be plumb in the full dead load condition, except at supports that do not deflect vertically in bridges for which all supports are radial. This out-of-plumbness should be considered in the detailing of the deck and bearings, as applicable.

In order for the girder webs of horizontally curved I-girder bridges with or without skewed supports to end up theoretically plumb under either the steel or full dead load condition, the cross-frames or diaphragms must again be detailed for that condition in order to introduce the necessary twist into the girders. In this case, however, as the cross-frames are forced into place and the girders are twisted out-of-plumb during the erection, the curved-girder flanges act to resist the induced change to their radii. Therefore, the Engineer may need to consider the potential for any problematic locked-in stresses in the girder flanges or the cross-frames or diaphragms when this method of detailing is specified for these types of bridges. The decision as to when these stresses should be evaluated is currently a matter of engineering judgment. It is anticipated that these stresses will be of little consequence in the vast majority of cases and that the resulting twist of the girders will be small enough that the cross-frames or diaphragms will easily pull the girders into their intended position and reverse any locked-in stresses as the dead load is applied.

For curved I-girder webs to end up theoretically plumb in the desired final condition without also theoretically inducing any additional locked-in stresses, the girders would have to be fabricated for the no-load position with a twist about the tangential axis of the girder for that particular condition. In such a case, the girder flanges would be welded square with respect to the webs and the cross-frames or diaphragms would be detailed for the desired final condition to correspond with the twist.

Such a practice is generally more costly and has found very limited use as of this writing (2005).

It should be noted that detailing of the cross-frames or diaphragms for the case where the girder webs are plumb in the no-load condition can result in the potential for many different connection-plate configurations. In this case, the drop of the cross-frames or diaphragms—or difference in elevation of the girders at the level of the cross-frames or diaphragms—typically varies causing the bolt holes in the connection plates to be different distances from the flanges.

Tub girders should be detailed to be normal to the crown of the roadway. Although the twist in I-girders is often greater than in tub girders, twist in tub girders may also be significant. Almost all horizontally curved tub girders are fabricated with a twist and are not erected with the girders plumb in the no-load condition. This is done because the inherent torsional stiffness of tub sections makes field adjustments difficult. Particular care must be taken in analyzing and detailing tub girders; in particular, tub girders in bridges with skewed supports.

For cases that begin to push the current limits of the specification or conventional practice, for example, cases with unusually long spans, tight radii, sharp skews, stiff and/or slender flanges in the lateral direction, special attention may be required by the Engineer. In cases where twist is introduced into the girders during the erection, slender flanges may be subject to local buckling and unusually stiff flanges may be difficult to push or pull into position in a practical manner.

6.7.3—Minimum Thickness of Steel

Structural steel, including bracing, cross-frames, and all types of gusset plates, except for webs of rolled shapes, closed ribs in orthotropic decks, fillers, and in railings, shall be not less than 0.3125 in. in thickness.

For orthotropic decks, the web thickness of rolled beams or channels and of closed ribs in orthotropic decks shall not be less than 0.25 in., the deck plate thickness shall not be less than 0.625 in. or four percent of the larger spacing of the ribs, and the thickness of closed ribs shall not be less than 0.1875.

Where the metal is expected to be exposed to severe corrosive influences, it shall be specially protected against corrosion or sacrificial metal thickness shall be specified.

6.7.4—Diaphragms and Cross-Frames

6.7.4.1—General

Diaphragms or cross-frames may be placed at the end of the structure, across interior supports, and intermittently along the span.

The need for diaphragms or cross-frames shall be investigated for all stages of assumed construction procedures and the final condition.

C6.7.3

For orthotropic decks, research and development and general design improvements domestically and abroad have demonstrated that a minimum deck plate thickness of 5/8 in. has addressed the causes of many problems resulting from overly flexible decks. Although analysis may indicate that deck plates less than 5/8 in. thick could be satisfactory, experience shows that a minimum thickness of 5/8 in. is advisable both from construction and long-term performance points of view.

C6.7.4.1

The arbitrary requirement for diaphragms spaced at not more than 25.0 ft in the AASHTO Standard Specifications has been replaced by a requirement for rational analysis that will often result in the elimination of fatigue-prone attachment details.

This investigation should include, but not be limited to, the following:

- Transfer of lateral wind loads from the bottom of the girder to the deck and from the deck to the bearings,
- Stability of the bottom flange for all loads when it is in compression,
- Stability of the top flange in compression prior to curing of the deck,
- Consideration of any flange lateral bending effects, and
- Distribution of vertical dead and live loads applied to the structure.

Diaphragms or cross-frames not required for the final condition may be specified to be temporary bracing. Metal stay-in-place deck forms should not be assumed to provide adequate stability to the top flange in compression prior to curing of the deck.

If permanent cross-frames or diaphragms are included in the structural model used to determine force effects, they shall be designed for all applicable limit states for the calculated force effects. At a minimum, diaphragms and cross-frames shall be designed to transfer wind loads according to the provisions of Article 4.6.2.7 and shall meet all applicable slenderness requirements in Article 6.8.4 or Article 6.9.3. Diaphragm and cross-frame members in horizontally curved bridges shall be considered to be primary members.

Connection plates for diaphragms and cross-frames shall satisfy the requirements specified in Article 6.6.1.3.1. Where the diaphragm flanges or cross-frame chords are not attached directly to the girder flanges, provisions shall be made to transfer the calculated horizontal force in diaphragms or cross-frames to the flanges through connection plates, except in cases where less than full-depth end angles or connection plates are used for connecting intermediate diaphragms as permitted in Article 6.6.1.3.1.

At the end of the bridge and intermediate points where the continuity of the slab is broken, the edges of the slab shall be supported by diaphragms or other suitable means as specified in Article 9.4.4.

6.7.4.2—I-Section Members

Diaphragms or cross-frames for rolled beams and plate girders should be as deep as practicable, but as a minimum should be at least 0.5 of the beam depth for rolled beams and 0.75 of the girder depth for plate girders. Cross-frames in horizontally curved bridges should contain diagonals and top and bottom chords.

Bracing of horizontally curved members is more critical than for straight members. Diaphragm and cross-frame members resist forces that are critical to the proper functioning of curved-girder bridges. Since they transmit the forces necessary to provide equilibrium, they are considered primary members. Therefore, forces in the bracing members must be computed and considered in the design of these members. When I-section members have been analyzed neglecting the effects of curvature according to the provisions of Article 4.6.1.2.4, the diaphragms or cross-frames may be analyzed by the V-load method (United States Steel, 1984) or other rational means.

If the diaphragm flanges or cross-frame chords are not attached directly to the girder flanges, forces from these elements are transferred through the connection plates. The eccentricity between the diaphragm flanges or cross-frame chords and the girder flanges should be recognized in the design of the connection plates and their connection to the web and flange.

The term connection plate as used herein refers to a transverse stiffener attached to the girder to which a cross-frame or diaphragm is connected.

C6.7.4.2

For the purpose of this Article, as it applies to horizontally curved girders, the term “normal” shall be taken to mean normal to a local tangent.

Intermediate diaphragms or cross-frames should be provided at nearly uniform spacing in most cases, for efficiency of the structural design, for constructibility,

End diaphragms shall be designed for forces and distortion transmitted by the deck and deck joint. End moments in diaphragms shall be considered in the design of the connection between the longitudinal component and the diaphragm. Diaphragms with span-to-depth ratios greater than or equal to 4.0 may be designed as beams.

Where supports are not skewed, intermediate diaphragms or cross-frames should be placed in contiguous lines normal to the girders.

Where support lines are not skewed more than 20 degrees from normal, intermediate diaphragms or cross-frames may be placed in contiguous skewed lines parallel to the skewed support lines.

Where support lines are skewed more than 20 degrees from normal, intermediate diaphragms or cross-frames shall be normal to the girders and may be placed in contiguous or discontinuous lines.

Where a support line at an interior pier is skewed more than 20 degrees from normal, elimination of the diaphragms or cross-frames along the skewed interior support line may be considered at the discretion of the Owner. Where discontinuous intermediate diaphragm or cross-frame lines are employed normal to the girders in the vicinity of that support line, a skewed or normal diaphragm or cross-frame should be matched with each bearing that resists lateral force.

If the end diaphragm or cross-frame is skewed, the effect of the tangential component of force transmitted by the skewed unit on the girder shall be considered.

Diaphragms or cross-frames at supports shall be proportioned to transmit all lateral components of force from the superstructure to the bearings that provide lateral restraint.

and/or to allow the use of simplified methods of analysis for calculation of flange lateral bending stresses, such as those discussed in Articles C4.6.1.2.4b, C4.6.2.7.1 and C6.10.3.4. Closer spacings may be necessary adjacent to interior piers, in the vicinity of skewed supports, and in some cases, near midspan.

Diaphragms with span-to-depth ratios less than 4.0 act as deep beams and should be evaluated by considering principal stresses rather than by beam theory.

Allowance of skewed intermediate diaphragms or cross-frames where support lines are not skewed more than 20 degrees from normal is consistent with past practice. Where support lines are skewed more than 20 degrees from normal, it may be advantageous to place the intermediate diaphragms or cross-frames oriented normal to the girders in discontinuous lines in such a manner that the transverse stiffness of the bridge is reduced, particularly in the vicinity of the supports. Placing the cross-frames in discontinuous lines has the effect of decreasing the cross-frame forces and increasing flange lateral bending. The actual flange lateral moments with discontinuous cross-frame lines may differ from those estimated using Eq. C4.6.1.2.4b-1, or equivalent, so a special investigation of flange lateral moments and cross-frame forces is advisable. Removal of highly stressed diaphragms or cross-frames, particularly near obtuse corners, releases the girders torsionally and is often beneficial as long as girder rotation is not excessive.

At severely skewed support lines at interior piers, detailing of the intersections of diaphragms or cross-frames along the skewed support line with intermediate diaphragms or cross-frames oriented normal to the girders is complex and, in many cases, the normal diaphragms or cross-frames alone should be sufficient to resist any lateral components of force that develop at the bearings. Where discontinuous intermediate diaphragm or cross-frame lines are employed normal to the girders in the vicinity of interior supports, care should be taken to match a diaphragm or cross-frame with each bearing that resists lateral force. Otherwise, the effect of the lateral moment induced in the bottom flange due the eccentricity between the intermediate diaphragm or cross-frame and the bearing should be considered. Also, whenever any bearing along that support line is not matched with a diaphragm or cross-frame, care should be taken to ensure that the bottom flange of the girder is adequately braced. For such cases, the provision of diaphragms or cross-frames along the skewed support line may be necessary. Refined analysis is recommended to allow for a more detailed examination of cross-frame forces, lateral bearing reactions, and lateral flange bending whenever removal of diaphragms or cross-frames along and/or in the vicinity of severely skewed interior support lines is considered. For skews not exceeding 20 degrees from normal, diaphragms or cross-frames along the skewed support line alone may be sufficient. In this case, intermediate diaphragms or cross-frames placed normal to the girders would likely be too

The spacing, L_b , of intermediate diaphragms or cross-frames in horizontally curved I-girder bridges shall not exceed the following in the erected condition:

$$L_b \leq L_r \leq R/10 \quad (6.7.4.2-1)$$

where:

- L_r = limiting unbraced length determined from Eq. 6.10.8.2.3-5 (ft)
 R = minimum girder radius within the panel (ft)

In no case shall L_b exceed 30.0 ft.

close together, introducing significant lateral bending into the girder flanges. For skewed diaphragms or cross-frames, connection plates should be oriented in the plane of the transverse bracing. The connection plate must be able to transfer force between the girder and the bracing without undue distortion. Welding of skewed connection plates to the girder may be problematic where the plate forms an acute angle with the girder.

The spacing of intermediate diaphragms and cross-frames in horizontally curved I-girder bridges in the erected condition is limited to $R/10$, which is consistent with past practice. The spacing is also limited to L_r from Eq. 6.10.8.2.3-5, where L_r is a limiting unbraced length to achieve the onset of nominal yielding in either flange under uniform bending with consideration of compression-flange residual stress effects prior to lateral torsional buckling of the compression flange. Limiting the unbraced length to L_r theoretically precludes elastic lateral torsional buckling of the compression flange. At unbraced lengths beyond L_r , significant flange lateral bending is likely to occur and the amplification factor for flange lateral bending specified in Article 6.10.1.6 will tend to become large even when an effective length factor for lateral torsional buckling and/or a moment gradient factor, C_b , is considered.

Eq. C6.7.4.2-1 may be used as a guide for preliminary framing in horizontally curved I-girder bridges:

$$L_b = \sqrt{\frac{5}{3} r_\sigma R b_f} \quad (C6.7.4.2-1)$$

where:

- b_f = flange width (ft)
 L_b = diaphragm or cross-frame spacing (ft)
 r_σ = desired bending stress ratio equal to $|f_c/f_{bu}|$
 R = girder radius (ft)

A maximum value of 0.3 may be used for the bending stress ratio, r_σ . Eq. C6.7.4.2-1 was derived from the V-load concept (Richardson, Gordon and Associates, 1976) and has been shown to yield a good correlation with three-dimensional finite-element analysis results if the cross-frame spacing is relatively uniform (Davidson et al., 1996).

6.7.4.3—Box Section Members

Diaphragms shall be provided within box sections at each support to resist cross-section distortion of the box and shall be designed to resist torsional moments in the box and transmit vertical and lateral forces from the box to the bearings.

For cross-sections consisting of two or more boxes, external cross-frames or diaphragms shall be used between the boxes at end supports. External cross-frames or diaphragms shall be provided between girder lines at interior supports, unless analysis indicates that the boxes

C6.7.4.3

Refined analysis of internal diaphragms at supports is desirable because these primary members are necessary for the integrity of the bridge. External diaphragms with aspect ratios, or ratios of length to depth, less than 4.0 and internal diaphragms act as deep beams and should be evaluated by considering principal stresses rather than by simple beam theory. Fatigue-sensitive details on these diaphragms and at the connection of the diaphragms to the flanges should be investigated considering the principal tensile stresses.

are torsionally stable without these members, particularly during erection. Internal cross-frames or diaphragms shall be provided at locations of external cross-frames or diaphragms.

If an internal plate diaphragm is provided for continuity or to resist torsional forces generated by structural members, it shall be connected to the webs and flanges of the box section. An access hole at least 18.0 in. wide and 24.0 in. high should be provided within each internal intermediate diaphragm. Design of the diaphragm shall consider the effect of the access hole on the stresses. Reinforcement around the hole may be required.

Intermediate internal diaphragms or cross-frames shall be provided. For all single box sections, horizontally curved sections, and multiple box sections in cross-sections of bridges not satisfying the requirements of Article 6.11.2.3 or with box flanges that are not fully effective according to the provisions of Article 6.11.1.1, the spacing of the internal diaphragms or cross-frames shall not exceed 40.0 ft.

Webs of internal and external diaphragms shall satisfy Eq. 6.10.1.10.2-2. The nominal shear resistance of internal and external diaphragm webs shall be determined from Eq. 6.10.9.3.3-1.

Boxes may undergo excessive rotation in some cases when the concrete deck is placed if intermediate diaphragms or cross-frames are not provided between boxes. If analysis shows that such rotations are anticipated, temporary cross-frames may be employed. Removal of such temporary members may lead to failure of remaining bolts, creating a safety concern. The effect of the release of bracing forces on the bridge can be investigated by considering the effect of reversal of member loads. Removal of temporary cross-frames having large forces may cause increased deck stresses.

Until the deck on a tub section hardens, internal cross-frames or diaphragms and lateral top flange bracing are required to stabilize the tub section. For straight boxes without skew satisfying the requirements of Article 6.11.2.3 and with fully effective box flanges, transverse bending stresses and longitudinal warping stresses due to cross-section distortion have often been shown to be small (Johnston and Mattock, 1967) and may be neglected. Torsion may be significant, however, if the deck weight acting on the box is unsymmetrical. A reduction in the number of permanent internal cross-frames or diaphragms and/or top lateral bracing members in such boxes is permitted when checked by proper analysis. Internal cross-frames or diaphragms should be placed at or near points of maximum moment and near both sides of field splices. The Engineer should also consider the need for additional temporary or permanent internal cross-frames or diaphragms, which may be required for transportation, construction, and at the lifting points of each shipping piece.

Cross-sectional distortion stresses are typically controlled by the internal cross-frames or diaphragms, with the spacing of these members not to exceed 40.0 ft for the cases specified herein. For the specific cases listed in Article 6.11.1.1, transverse bending stresses due to cross-section distortion are explicitly limited to 20.0 ksi at the strength limit state. Adequate internal cross-frames or diaphragms must be introduced to meet this limit, and should also be designed to control the longitudinal warping stresses due to the critical factored torsional loads. Such stresses should not exceed approximately ten percent of the longitudinal stresses due to major-axis bending at the strength limit state.

In cases with widely spaced internal cross-frames or diaphragms, additional struts between the top flanges of tub sections may be necessary in order to satisfy the constructibility provisions of Article 6.11.3.2. As indicated in Article C6.11.3.2, struts that are part of top lateral bracing systems attached to the flanges at points where internal cross-frames or diaphragms do not exist may be considered to act as brace points at the discretion of the Engineer.

Where distortion of the section is adequately controlled by the internal cross-frames or diaphragms, acting in conjunction with a top lateral bracing system in the case of tub sections, the St. Venant torsional inertia, J , for a box section may be determined as:

$$J = 4 \frac{A_o^2}{\sum \frac{b}{t}} \quad (\text{C6.7.4.3-1})$$

where:

- A_o = area enclosed by the box section (in.²)
 b = width of rectangular plate element (in.)
 t = thickness of plate (in.)

In tub sections with inclined webs with a slope exceeding 1 to 4 and/or where the unbraced length of the top flanges exceeds 30.0 ft, additional intermediate internal cross-frames, diaphragms, or struts may be required to increase the resistance of discretely braced top flanges of tub sections to lateral bending resulting from a uniformly distributed transverse load acting on the flanges. This lateral load results from the change in the horizontal component of the web dead load shear plus the change in the St. Venant torsional dead load shear per unit length along the member, and is discussed further in Article C6.11.3.2.

Because of the critical nature of internal and external diaphragms, particularly at supports, any reliance on post-buckling resistance is not advisable. Satisfaction of Eq. 6.10.1.10.2-2 ensures that theoretical bend buckling of internal and external diaphragm webs will not occur for elastic stress levels at or below the yield stress.

Limiting the nominal shear resistance of diaphragm webs to the shear buckling or shear yield resistance according to Eq. 6.10.9.3.3-1 prevents any reliance on post-buckling shear resistance. Bearing stiffeners on internal diaphragms act as transverse stiffeners in computing the nominal shear resistance.

A portion of the box flange width equal to six times its thickness may be considered effective with an internal diaphragm.

The attachment of internal cross-frame connection plates to box flanges is discussed further in Article C6.6.1.3.1.

6.7.4.4—Trusses and Arches

Diaphragms shall be provided at the connections to floorbeams and at other connections or points of application of concentrated loads. Internal diaphragms may also be provided to maintain member alignment.

Gusset plates engaging a pedestal pin at the end of a truss shall be connected by a diaphragm. The webs of the pedestal should be connected by a diaphragm wherever practical.

If the end of the web plate or cover plate is 4.0 ft or more from the point of intersection of the members, a diaphragm shall be provided between gusset plates engaging main members.

6.7.5—Lateral Bracing

6.7.5.1—General

The need for lateral bracing shall be investigated for all stages of assumed construction procedures and the final condition.

Where required, lateral bracing should be placed either in or near the plane of a flange or chord being braced. Investigation of the requirement for lateral bracing shall include, but not be limited to:

- Transfer of lateral wind loads to the bearings as specified in Article 4.6.2.7,
- Transfer of lateral loads as specified in Article 4.6.2.8, and
- Control of deformations and cross-section geometry during fabrication, erection, and placement of the deck.

Lateral bracing members not required for the final condition should not be considered to be primary members, and may be removed at the Owner's discretion.

If permanent lateral bracing members are included in the structural model used to determine live load force effects, they shall be designed for all applicable limit states and shall be considered to be primary members. The provisions of Articles 6.8.4 and 6.9.3 shall apply.

Connection plates for lateral bracing shall satisfy the requirements specified in Article 6.6.1.3.2.

When lateral bracing is designed for seismic loading, the provisions of Article 4.6.2.8 shall apply.

6.7.5.2—I-Section Members

Continuously braced flanges should not require lateral bracing.

The need for lateral bracing adjacent to supports of I-girder bridges to provide rigidity during construction should be considered.

C6.7.5.1

In I-girder bridges, bottom flange lateral bracing creates a pseudo-closed section formed by the I-girders connected with the bracing and the hardened deck, and therefore becomes load carrying. Cross-frame forces increase with the addition of bottom flange bracing because the cross-frames act to retain the shape of the pseudo-box section. In addition, moments in the braced girders become more equalized and the bracing members are also subject to significant live load forces.

C6.7.5.2

Wind-load stresses in I-sections may be reduced by:

- Changing the flange size,
- Reducing the diaphragm or cross-frame spacing, or
- Adding lateral bracing.

The relative economy of these methods should be investigated.

To help prevent significant relative horizontal movement of the girders in spans greater than 200 ft during construction, it may be desirable to consider providing either temporary or permanent lateral bracing in one or more panels adjacent to the supports of I-girder bridges. For continuous-span bridges, such bracing would only be necessary adjacent to interior supports and should be considered at the free ends of continuous units. Such a system of lateral bracing can also provide a stiffer load path for wind loads acting on the noncomposite structure during construction to help reduce the lateral deflections and flange lateral bending stresses. Top lateral bracing is preferred. Bottom lateral bracing can provide a similar function, but unlike top bracing, would be

6.7.5.3—Tub Section Members

Top lateral bracing shall be provided between common flanges of individual tub sections. For straight girders, the need for a full-length lateral bracing system shall be investigated to ensure that deformations of the tub section are adequately controlled and that stability of the tub section members is provided during erection and placement of the concrete deck. During deck casting, the stability of the compression flanges between panel points of the lateral bracing system shall be investigated. If a full-length lateral bracing system is not provided, the local stability of the top flanges and global stability of the individual tub sections shall be investigated for the Engineer's assumed construction sequence. For horizontally curved girders, a full-length lateral bracing system shall be provided and the stability of compression flanges between panel points of the lateral bracing system shall be investigated during deck casting.

Top lateral bracing shall be designed to resist shear flow in the pseudo-box section due to the factored loads before the concrete deck has hardened or is made composite. Forces in the bracing due to flexure of the tub shall also be considered during construction based on the Engineer's assumed construction sequence.

If the bracing is attached to the webs, the cross-sectional area of the tub for shear flow shall be reduced to reflect the actual location of the bracing, and a means of transferring the forces from the bracing to the top flange shall be provided.

subject to significant live load forces in the finished structure that would have to be considered.

For horizontally curved bridges, when the curvature is sharp and temporary supports are not practical, it may be desirable to consider providing both top and bottom lateral bracing to ensure pseudo-box action while the bridge is under construction. Top and bottom lateral bracing provides stability to a pair of I-girders.

If temporary lateral bracing is used, the analysis method used must be able to recognize influence of the lateral bracing.

C6.7.5.3

Investigation will generally show that a lateral bracing system is not required between multiple tub sections.

The shear center of an open tub section is located below the bottom flange (Heins, 1975). The addition of top lateral bracing raises the shear center closer to the center of the resulting pseudo-box section, significantly improving the torsional stiffness.

In addition to resisting the shear flow before the concrete deck has hardened or is made composite, top lateral bracing members are also subject to significant forces due to flexure of the noncomposite tub. In the absence of a more refined analysis, Fan and Helwig (1999) provide an approach for estimating these forces.

Top lateral bracing members are also subject to forces due to wind loads acting on the noncomposite pseudo-box section during construction.

For straight tub sections with spans less than about 150 ft, as a minimum, at least one panel of horizontal lateral bracing should be provided within the tub on each side of a lifting point. The need for additional lateral bracing to resist the shear flow resulting from any net torque on the steel section due to unequal factored deck weight loads acting on each side of the top flanges, or any other known eccentric loads acting on the steel section during construction, should be considered. Cross-section distortion and top-flange lateral bending stresses may need to be considered when a tub with a partial-length bracing system is subjected to a net torque. A full-length lateral bracing system should be considered for cases where the torques acting on the steel section are deemed particularly significant, e.g. tub-section members resting on skewed supports and/or tub-section members on which the deck is unsymmetrically placed. If a full-length system is not provided in a straight tub-section member, the Engineer must ensure the local and global stability of the top flanges and the tub-section member, respectively, during the assumed construction sequence. For straight tub sections with spans greater than about 150 ft, a full-length lateral bracing system should be provided within the tub.

For both straight and horizontally curved tub sections, a full-length lateral bracing system forms a pseudo-box to help limit distortions brought about by temperature changes occurring prior to concrete deck

placement, and to resist the torsion and twist caused by any eccentric loads acting on the steel section during construction. AASHTO (1993) specified that diagonal members of the top lateral bracing for tub sections satisfy the following criterion:

$$A_d \geq 0.03w \quad (\text{C6.7.5.3-1})$$

where:

- A_d = minimum required cross-sectional area of one diagonal (in.²)
 w = center-to-center distance between the top flanges (in.)

Satisfaction of this criterion was intended to ensure that the top lateral bracing would be sized so that the tub would act as a pseudo-box section with minimal warping torsional displacement and normal stresses due to warping torsion less than or equal to ten percent of the major-axis bending stresses. This criterion was developed assuming tub sections with vertical webs and ratios of section width-to-depth between 0.5 and 2.0, and an X-type top lateral bracing system with the diagonals placed at an angle of 45 degrees relative to the longitudinal centerline of the tub-girder flanges (Heins, 1978). Although this criterion may not necessarily be directly applicable to other bracing configurations and cross-section geometries, it is recommended that Eq. C6.7.5.3-1 still be used as a guideline to ensure that a reasonable minimum area is provided for the diagonal bracing members.

Single-diagonal top lateral bracing systems are preferred over X-type systems because there are fewer pieces to fabricate and erect and fewer connections. However, forces in alternating Warren-type single-diagonal top lateral bracing members, as shown in Figure C6.7.5.3-1, due to flexure of the tub section can sometimes result in the development of significant lateral bending stresses in the top flanges. In lieu of a refined analysis, Fan and Helwig (1999) provide an approach for estimating the top-flange lateral bending stresses due to these forces. If necessary, the flange lateral bending stresses and forces in the bracing members in this case can often be effectively mitigated by the judicious placement of parallel single-diagonal members, or a Pratt-type configuration, in each bay in lieu of a Warren-type configuration as shown in Figure C6.7.5.3-2. In this configuration, the members should be oriented based on the sign of the torque so that the forces induced in these members due to torsion offset the compressive or tensile forces induced in the same members due to flexure of the tub section. The forces in the lateral bracing system are very sensitive to the casting sequence. If the member sizes have been optimized based upon an assumed casting sequence, it is imperative that the assumed casting sequence be shown in the contract documents. Field tests have shown that forces in the top lateral system after the deck has been cast are negligible.

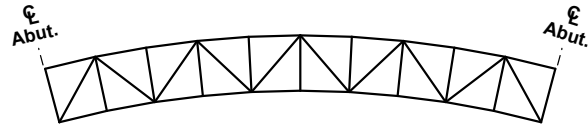

Figure C6.7.5.3-1—Warren-Type Single-Diagonal Top Lateral Bracing System for Tub Section Member: Plan View

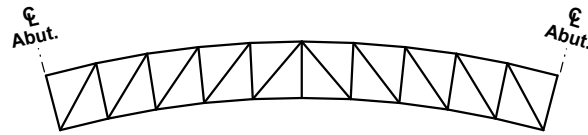

Figure C6.7.5.3-2—Pratt-Type Single-Diagonal Top Lateral Bracing System for Tub Section Member: Plan View

Where the forces in the bracing members are not available from a refined analysis, the shear flow across the top of the pseudo-box section can be computed from Eq. C6.11.1.1-1 assuming the top lateral bracing acts as an equivalent plate. The resulting shear can then be computed by multiplying the resulting shear flow by the width w , and the shear can then be resolved into the diagonal bracing member(s). Should it become necessary for any reason to compute the St. Venant torsional stiffness of the pseudo-box section according to Eq. C6.7.4.3-1, formulas are available (Kollbrunner and Basler, 1966; Dabrowski, 1968) to calculate the thickness of the equivalent plate for different possible configurations of top lateral bracing.

Top lateral bracing should be continuous across field splice locations.

6.7.5.4—Trusses

Through-truss spans and deck truss spans shall have top and bottom lateral bracing. If an x-system of bracing is used, each member may be considered effective simultaneously if the members meet the slenderness requirements for both tension and compression members. The members should be connected at their intersections.

The member providing lateral bracing to compression chords should be as deep as practical and connected to both flanges.

Floorbeam connections should be located so that the lateral bracing system will engage both the floorbeam and the main supporting members. Where the lateral bracing system intersects a joint formed by a floorbeam and a main longitudinal member, the lateral member shall be connected to both members.

6.7.6—Pins

6.7.6.1—Location

Pins should be located so as to minimize the force effects due to eccentricity.

6.7.6.2—Resistance*6.7.6.2.1—Combined Flexure and Shear**C6.7.6.2.1*

Pins subjected to combined flexure and shear shall be proportioned to satisfy:

The development of Eq. 6.7.6.2.1-1 is discussed in Kulicki (1983).

$$\frac{6.0 M_u}{\phi_f D^3 F_y} + \left(\frac{2.2 V_u}{\phi_v D^2 F_y} \right)^3 \leq 0.95 \quad (6.7.6.2.1-1)$$

where:

- D = diameter of pin (in.)
- M_u = moment due to the factored loads (kip-in.)
- V_u = shear due to the factored loads (kip)
- F_y = specified minimum yield strength of the pin (ksi)
- ϕ_f = resistance factor for flexure as specified in Article 6.5.4.2
- ϕ_v = resistance factor for shear as specified in Article 6.5.4.2

The moment, M_u , and shear, V_u , should be taken at the same design section along the pin.

*6.7.6.2.2—Bearing**C6.7.6.2.2*

The factored bearing resistance on pins shall be taken as:

$$(R_{pB})_r = \phi_b (R_{pB})_n \quad (6.7.6.2.2-1)$$

in which:

$$(R_{pB})_n = 1.5tDF_y \quad (6.7.6.2.2-2)$$

where:

- t = thickness of plate (in.)
- D = diameter of pin (in.)
- ϕ_b = resistance factor for bearing as specified in Article 6.5.4.2

For the design of new pins subjected to significant rotations, such as for rocker bearings or hinges, the coefficient 1.5 in Eq. 6.7.6.2.2-2 may be halved to 0.75 at the discretion of the Engineer. This accounts for increased wear over the life of pins used for applications with significant rotations. An equivalent approach to that suggested above was used for allowable stress design in the AASHTO Standard Specifications. For the evaluation of existing pins subjected to significant rotations, the 1.5 coefficient in Eq. 6.7.6.2.2-2 should not be halved.

6.7.6.3—Minimum Size Pin for Eyebars

The diameter of the pin, D , shall satisfy:

$$D \geq \left(\frac{3}{4} + \frac{F_y}{400} \right) b \quad (6.7.6.3-1)$$

where:

- F_y = specified minimum yield strength of the eyebar (ksi)
- b = width of the body of the eyebar (in.)

6.7.6.4—Pins and Pin Nuts

Pins shall be of sufficient length to secure a full bearing of all parts connected upon the turned body of the pin. The pin shall be secured in position by:

- Hexagonal recessed nuts,
- Hexagonal solid nuts with washers, or
- If the pins are bored through, a pin cap restrained by pin rod assemblies.

Pin or rod nuts shall be malleable castings or steel and shall be secured in position by cotter pins through the threads or by burring the threads. Commercially available lock nuts may be used as an alternate to burring the threads or use of cotter pins.

6.7.7—Heat-Curved Rolled Beams and Welded Plate Girders

6.7.7.1—Scope

This section pertains to rolled beams and welded I-section plate girders heat-curved to obtain a horizontal curvature. Structural steels conforming to AASHTO M 270M/M 270 (ASTM A709/A709M), Grades 36, 50, 50S, 50W, HPS 50W, HPS 70W or HPS 100W (Grades 250, 345, 345S, 345W, HPS 345W, HPS 485W or HPS 690W) may be heat-curved.

6.7.7.2—Minimum Radius of Curvature

For heat-curved beams and girders, the horizontal radius of curvature measured to the centerline of the girder web shall not be less than 150 ft and shall not be less than the larger of the values calculated from the following two equations:

$$R = \frac{14bD}{\sqrt{F_{yw}\Psi t_w}} \quad (6.7.7.2-1)$$

$$R = \frac{7,500b}{F_{yw}\Psi} \quad (6.7.7.2-2)$$

where:

- Ψ = ratio of the total cross-sectional area to the cross-sectional area of both flanges
 b = widest flange width (in.)
 D = clear distance between flanges (in.)
 F_{yw} = specified minimum yield strength of a web (ksi)
 R = radius of curvature (in.)

In addition to the above requirements, the radius shall not be less than 1,000 ft when the flange thickness exceeds 3.0 in. or the flange width exceeds 30.0 in.

6.7.7.3—Camber

Where additional camber is specified in the contract documents to compensate for possible loss of camber of heat-curved girders in service as residual stresses dissipate, the amount of camber in inches, Δ , at any section along the length L of the girder shall be equal to:

$$\Delta = \frac{\Delta_{DL}}{\Delta_M} (\Delta_M + \Delta_R) \quad (6.7.7.3-1)$$

in which:

$$\Delta_R = \frac{0.02L^2 F_{yf}}{EY_o} \left(\frac{1,000 - R}{850} \right) \quad (6.7.7.3-2)$$

where:

- Δ_{DL} = camber at any point along the length L calculated by usual procedures to compensate for deflection due to dead loads or any other specified loads (in.)
- Δ_M = maximum value of Δ_{DL} within the length L (in.)
- F_{yf} = specified minimum yield strength of a flange (ksi)
- Y_o = distance from the neutral axis to the extreme outer fiber of the cross-section (in.)
- R = radius of curvature (ft)
- L = span length for simple spans or for continuous spans, the distance between a simple end support and the permanent load contraflexure point, or the distance between points of permanent load contraflexure (in.)

Camber loss between permanent load contraflexure points adjacent to piers is small and may be neglected.

6.8—TENSION MEMBERS**6.8.1—General**

Members and splices subjected to axial tension shall be investigated for:

- Yield on the gross section using Eq. 6.8.2.1-1 and
- Fracture on the net section using Eq. 6.8.2.1-2.

Holes larger than those typically considered for connectors such as bolts shall be deducted in determining the gross section area.

The determination of the net section shall require consideration of:

- The gross area from which deductions will be made or reduction factors applied, as appropriate;
- Deductions for all holes in the design cross-section;

C6.7.7.3

Part of the camber loss is attributable to construction loads and will occur during construction of the bridge; total camber loss will be complete after several months of in-service loads. Therefore, a portion of the camber increase should be included in the bridge profile. In lieu of other guidelines, camber may be adjusted by one-half of the camber increase. Camber losses of this nature, but generally smaller in magnitude, are also known to occur in straight beams and girders.

For radii greater than 1,000 ft, Δ_R should be taken equal to zero.

See also Article 11.8.3.3.1 of the *AASHTO LRFD Bridge Construction Specifications*.

C6.8.1

Holes typically deducted when determining the gross section include pin holes, access holes, and perforations.

- Correction of the bolt hole deductions for the stagger rule specified in Article 6.8.3;
- Application of the reduction factor U specified in Article 6.8.2.2 for members and Article 6.13.5.2 for splice plates and other splicing elements to account for shear lag; and
- Application of the 85-percent maximum area efficiency factor for splice plates and other splicing elements specified in Article 6.13.5.2.

Tension members shall satisfy the slenderness requirements specified in Article 6.8.4 and the fatigue requirements of Article 6.6.1. Block shear strength shall be investigated at end connections as specified in Article 6.13.4.

6.8.2—Tensile Resistance

6.8.2.1—General

The factored tensile resistance, P_r , shall be taken as the lesser of the values given by Eqs. 6.8.2.1-1 and 6.8.2.1-2.

$$P_r = \phi_y P_{ny} = \phi_y F_y A_g \quad (6.8.2.1-1)$$

$$P_r = \phi_u P_{nu} = \phi_u F_u A_n R_p U \quad (6.8.2.1-2)$$

where:

- P_{ny} = nominal tensile resistance for yielding in gross section (kip)
- F_y = specified minimum yield strength (ksi)
- A_g = gross cross-sectional area of the member (in.²)
- F_u = tensile strength (ksi)
- A_n = net area of the member as specified in Article 6.8.3 (in.²)
- R_p = reduction factor for holes taken equal to 0.90 for bolt holes punched full size and 1.0 for bolt holes drilled full size or subpunched and reamed to size
- U = reduction factor to account for shear lag; 1.0 for components in which force effects are transmitted to all elements, and as specified in Article 6.8.2.2 for other cases
- ϕ_y = resistance factor for yielding of tension members as specified in Article 6.5.4.2
- ϕ_u = resistance factor for fracture of tension members as specified in Article 6.5.4.2

C6.8.2.1

The reduction factor, U , does not apply when checking yielding on the gross section because yielding tends to equalize the nonuniform tensile stresses caused over the cross-section by shear lag. The reduction factor, R_p , conservatively accounts for the reduced fracture resistance in the vicinity of bolt holes that are punched full size (Brown et al., 2007). No reduction in the net section fracture resistance is required for holes that are drilled full size or subpunched and reamed to size. The reduction in the factored resistance for punched holes was previously accounted for by increasing the hole size for design by $1/16$ in., which penalized drilled and subpunched and reamed holes and did not provide a uniform reduction for punched holes since the reduction varied with the hole size.

Due to strain hardening, a ductile steel loaded in axial tension can resist a force greater than the product of its gross area and its yield strength prior to fracture. However, excessive elongation due to uncontrolled yielding of gross area not only marks the limit of usefulness but it can precipitate failure of the structural system of which it is a part. Depending on the ratio of net area to gross area and the mechanical properties of the steel, the component can fracture by failure of the net area at a load smaller than that required to yield the gross area. General yielding of the gross area and fracture of the net area both constitute measures of component strength. The relative values of the resistance factors for yielding and fracture reflect the different reliability indices deemed proper for the two modes.

The part of the component occupied by the net area at fastener holes generally has a negligible length relative to the total length of the member. As a result, the strain hardening is quickly reached and, therefore, yielding of the net area at fastener holes does not constitute a strength limit of practical significance, except perhaps for some builtup members of unusual proportions.

For welded connections, A_n is the gross section less any access holes in the connection region.

6.8.2.2—Reduction Factor, U

The shear lag reduction factor, U , shall be used when investigating the tension fracture check specified in Article 6.8.1 at the strength limit state.

In the absence of more refined analysis or tests, the reduction factors specified herein may be used to account for shear lag in connections.

The shear lag reduction factor, U , may be calculated as specified in Table 6.8.2.2-1. For members composed of more than one element, the calculated value of U should not be taken to be less than the ratio of the gross area of the connected element or elements to the member gross area.

C6.8.2.2

The provisions of Article 6.8.2.2 are adapted from the 2005 AISC Specification Section D3.3, Effective Net Area for design of tension members. The 2005 AISC provisions are adapted such that they are consistent with updated draft 2010 AISC provisions. These updated provisions specify that, for members composed of more than one element, the calculated value of U should not be taken to be less than the ratio of the gross area of the connected element or elements to the member gross area.

Examples of the distances \bar{x} and L used in the calculation of the reduction factor U for all types of tension members, except plates and Hollow Structural Section (HSS) members, are illustrated in Figure C6.8.2.2-1.

Table 6.8.2.2-1—Shear Lag Factors for Connections to Tension Members

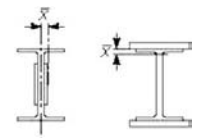
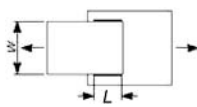
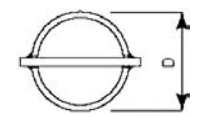
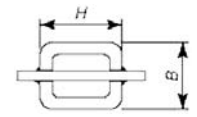
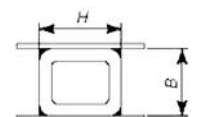
Case	Description of Element		Shear Lag Factor, U	Example
1	All tension members where the tension load is transmitted directly to each of cross-sectional elements by fasteners or welds (except as in Cases 3, 4, 5, and 6).		$U = 1.0$	—
2	All tension members, except plates and HSS, where the tension load is transmitted to some but not all of the cross-sectional elements by fasteners or longitudinal welds. (Alternatively, for W, M, S, and HP, Case 7 may be used.)		$U = 1 - \frac{\bar{x}}{L}$	
3	All tension members where the tension load is transmitted by transverse welds to some but not all of the cross-sectional elements.		$U = 1.0$ and $A =$ area of the directly connected elements	—
4	Plates where the tension load is transmitted by longitudinal welds only.		$L \geq 2w \dots U = 1.0$ $2w > L \geq 1.5w \dots U = 0.87$ $1.5w > L \geq w \dots U = 0.75$	
5	Round HSS with a single concentric gusset plate.		$L \geq 1.3D \dots U = 1.0$ $D \leq L < 1.3D \dots U = 1 - \frac{\bar{x}}{L}$ $\bar{x} = \frac{D}{\pi}$	
6	Rectangular HSS	with a single concentric gusset plate	$L \geq H \dots U = 1 - \frac{\bar{x}}{L}$ $\bar{x} = \frac{B^2 + 2BH}{4(B + H)}$	
		with 2 side gusset plates	$L \geq H \dots U = 1 - \frac{\bar{x}}{L}$ $\bar{x} = \frac{B^2}{4(B + H)}$	
7	W, M, S, or HP Shapes or Tees cut from these shapes (If U is calculated per Case 2, the larger value is permitted to be used.)	with flange connected with 3 or more fasteners per line in direction of loading	$b_f \geq \frac{2}{3}d \dots U = 0.90$ $b_f < \frac{2}{3}d \dots U = 0.85$	—
		with web connected with 4 or more fasteners in direction of loading	$U = 0.70$	—
8	Single angles (If U is calculated per Case 2, the larger value is permitted to be used.)	with 4 or more fasteners per line in direction of loading	$U = 0.80$	—
		with 2 or 3 fasteners per line in direction of loading	$U = 0.60$	—

where:

- L = length of connection (in.)
- w = plate width (in.)
- \bar{x} = connection eccentricity (in.)
- B = overall width of rectangular HSS member, measured 90 degrees to the plane of the connection (in.)
- H = overall height of rectangular HSS member, measured in the plane of the connection (in.)
- d = full nominal depth of section (in.)
- b_f = flange width (in.)

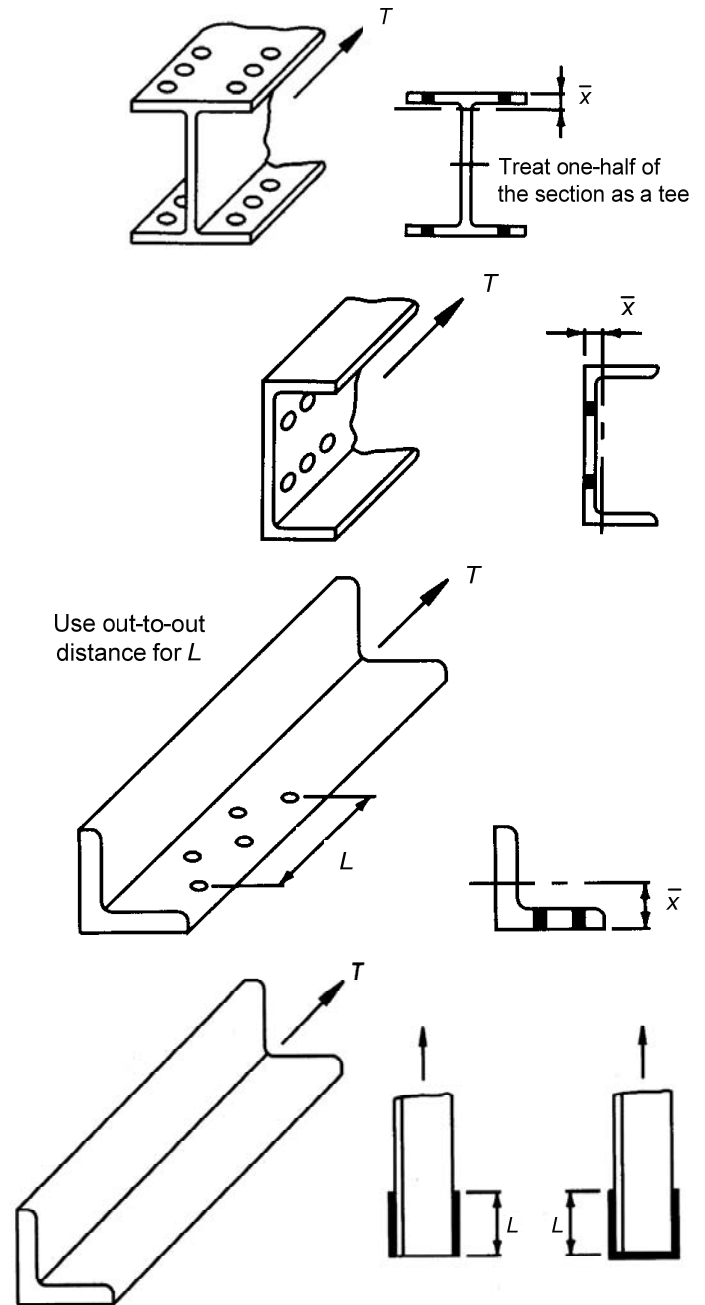

Figure C6.8.2.2-1—Determination of \bar{x} or L in the Calculation of the Shear Lag Reduction Factor, U

For members with combinations of longitudinal and transverse welds, L is the maximum length of the longitudinal welds. The transverse weld does not significantly affect the fracture resistance based on shear lag. The presence of the transverse weld does little to influence the transfer of the load into the unattached elements of the member cross-section. The connection length L is defined for general cases as the maximum length of the longitudinal welds or the out-to-out distance between the bolts in the connection parallel to the line of force (in.).

6.8.2.3—Combined Tension and Flexure

A component subjected to tension and flexure shall satisfy Eq. 6.8.2.3-1 or 6.8.2.3-2.

If $\frac{P_u}{P_r} < 0.2$, then

$$\frac{P_u}{2.0 P_r} + \left(\frac{M_{ux}}{M_{rx}} + \frac{M_{uy}}{M_{ry}} \right) \leq 1.0 \quad (6.8.2.3-1)$$

If $\frac{P_u}{P_r} \geq 0.2$, then

$$\frac{P_u}{P_r} + \frac{8.0}{9.0} \left(\frac{M_{ux}}{M_{rx}} + \frac{M_{uy}}{M_{ry}} \right) \leq 1.0 \quad (6.8.2.3-2)$$

where:

- P_r = factored tensile resistance as specified in Article 6.8.2.1 (kip)
- M_{rx} = factored flexural resistance about the x -axis taken as ϕ_f times the nominal flexural resistance about the x -axis determined as specified in Article 6.10, 6.11 or 6.12, as applicable (kip-in.)
- M_{ry} = factored flexural resistance about the y -axis taken as ϕ_f times the nominal flexural resistance about the y -axis determined as specified in Article 6.12, as applicable (kip-in.)
- M_{ux}, M_{uy} = moments about the x - and y -axes, respectively, resulting from factored loads (kip-in.)
- P_u = axial force effect resulting from factored loads (kip)
- ϕ_f = resistance factor for flexure specified in Article 6.5.4.2

The stability of a flange subjected to a net compressive stress due to the tension and flexure shall be investigated for local buckling.

C6.8.2.3

Interaction equations in tension and compression members are a design simplification. Such equations involving exponents of 1.0 on the moment ratios are usually conservative. More exact, nonlinear interaction curves are also available and are discussed in Galambos (1998). If these interaction equations are used, additional investigation of service limit state stresses is necessary to avoid premature yielding.

For sections where the nominal flexural resistance about the x -axis is expressed in terms of stress, the factored flexural resistance about the x -axis in Eqs. 6.8.2.3-1 and 6.8.2.3-2 should be taken as:

$$M_{rx} = \text{the smaller of } \phi_f F_{nc} S_{xc} \text{ and } \phi_f F_{nt} S_{xt} \quad (C6.8.2.3-1)$$

where:

- F_{nc} = nominal flexural resistance of the compression flange (ksi)
- F_{nt} = nominal flexural resistance of the tension flange (ksi)
- M_{yc} = yield moment with respect to the compression flange determined as specified in Article D6.2 (kip-in.)
- M_{yt} = yield moment with respect to the tension flange determined as specified in Article D6.2 (kip-in.)
- S_{xc} = elastic section modulus about the major axis of the section to the compression flange taken as M_{yc}/F_{yc} (in.³)
- S_{xt} = elastic section modulus about the major axis of the section to the tension flange taken as M_{yt}/F_{yt} (in.³)

S_{xc} and S_{xt} are defined in this fashion as equivalent values that account for the combined effects of the loads acting on different sections in composite members.

For sections where the nominal flexural resistance about the x -axis is determined according to the provisions of Appendix A6, the factored flexural resistance about the x -axis should be taken as:

$$M_{rx} = \text{the smaller of } \phi_f M_{nc} \text{ and } \phi_f M_{nt} \quad (C6.8.2.3-2)$$

where:

- M_{nc} = nominal flexural resistance based on the compression flange (kip-in.)
- M_{nt} = nominal flexural resistance based on the tension flange (kip-in.)

For I- and H-shaped sections, the nominal flexural resistance about the y -axis is determined according to the provisions of Article 6.12.2.2.1.

For tees and double angles subject to combined axial tension and flexure in which the axial and flexural stresses in the flange of the tee or the connected legs of the angles are additive in tension, e.g., when a tee is used as a bracing member and the connection of this member is made to the flange, a bulge in the interaction curve occurs. As a result, Eqs. 6.8.2.3-1 and 6.8.2.3-2 may significantly underestimate the resistance in such cases. Alternative approaches attempting to capture this bulge have proven to be generally inconclusive or incomplete as of this writing (2009). In the interim, it is recommended that Eqs. 6.8.2.3-1 and 6.8.2.3-2 be conservatively applied to these cases. Should significant additional resistance be required, the use of one or more of these alternative approaches, as described in White (2006), may be considered.

6.8.3—Net Area

The net area, A_n , of an element is the product of the thickness of the element and its smallest net width. The width of each standard bolt hole shall be taken as the nominal diameter of the hole. The width of oversize and slotted holes, where permitted for use in Article 6.13.2.4.1, shall be taken as the nominal diameter or width of the hole, as applicable, specified in Article 6.13.2.4.2. The net width shall be determined for each chain of holes extending across the member or element along any transverse, diagonal, or zigzag line.

The net width for each chain shall be determined by subtracting from the width of the element the sum of the widths of all holes in the chain and adding the quantity $s^2/4g$ for each space between consecutive holes in the chain, where:

- s = pitch of any two consecutive holes (in.)
 g = gage of the same two holes (in.)

For angles, the gage for holes in opposite adjacent legs shall be the sum of the gages from the back of the angles less the thickness.

6.8.4—Limiting Slenderness Ratio

Tension members other than rods, eyebars, cables, and plates shall satisfy the slenderness requirements specified below:

- For primary members subject to stress reversals $\frac{\ell}{r} \leq 140$

C6.8.3

The development of the “ $s^2/4g$ ” rule for estimating the effect of a chain of holes on the tensile resistance of a section is described in McGuire (1968). Although it has theoretical shortcomings, it has been used for a long time and has been found to be adequate for ordinary connections.

In designing a tension member, it is conservative and convenient to use the least net width for any chain together with the full tensile force in the member. It is sometimes possible to achieve an acceptable, slightly less conservative design by checking each possible chain with a tensile force obtained by subtracting the force removed by each bolt ahead of that chain, i.e., closer to midlength of the member from the full tensile force in the member. This approach assumes that the full force is transferred equally by all bolts at one end.

- For primary members not subject to stress reversals $\frac{\ell}{r} \leq 200$
- For secondary members $\frac{\ell}{r} \leq 240$

where:

ℓ = unbraced length (in.)
 r = radius of gyration (in.)

6.8.5—Builtup Members

6.8.5.1—General

The main elements of tension members built up from rolled or welded shapes shall be connected by continuous plates with or without perforations or by tie plates with or without lacing. Welded connections between shapes and plates shall be continuous. Bolted connections between shapes and plates shall conform to the provisions of Article 6.13.2.

6.8.5.2—Perforated Plates

The ratio of length in the direction of stress to width of holes shall not exceed 2.0.

The clear distance between holes in the direction of stress shall not be less than the transverse distance between the nearest line of connection bolts or welds. The clear distance between the end of the plate and the first hole shall not be less than 1.25 times the transverse distance between bolts or welds.

The periphery of the holes shall have a minimum radius of 1.5 in.

The unsupported widths at the edges of the holes may be assumed to contribute to the net area of the member. Where holes are staggered in opposite perforated plates the net area of the member shall be considered the same as for a section having holes in the same transverse plane.

6.8.6—Eyebars

6.8.6.1—Factored Resistance

The factored resistance of the body of the eyebar shall be taken as specified in Eq. 6.8.2.1-1.

6.8.6.2—Proportions

Eyebars shall have a uniform thickness not less than 0.5 in. or more than 2.0 in.

The transition radius between the head and the body of an eyebar shall not be less than the width of the head at the centerline of the pin hole.

C6.8.5.1

Perforated plates, rather than tie plates and/or lacing, are now used almost exclusively in builtup members. However, tie plates with or without lacing may be used where special circumstances warrant. Limiting design proportions are given in AASHTO (2002) and AISC (2005).

C6.8.6.1

Eq. 6.8.2.1-2 does not control because the net section in the head is at least 1.35 greater than the section in the body.

C6.8.6.2

The net width of the head at the centerline of the pin hole shall not be less than 135 percent the required width of the body.

The net dimension of the head beyond the pin hole taken in the longitudinal direction shall not be less than 75 percent of the width of the body.

The width of the body shall not exceed eight times its thickness.

The center of the pin hole shall be located on the longitudinal axis of the body of the eyebar. The pin-hole diameter shall not be more than 0.03125 in. greater than the pin diameter.

For steels having a specified minimum yield strength greater than 70 ksi, the hole diameter shall not exceed five times the eyebar thickness.

6.8.6.3—Packing

The eyebars of a set shall be symmetrical about the central plane of the member and as parallel as practicable. They shall be restrained against lateral movement on the pins and against lateral distortion due to the skew of the bridge.

The eyebars shall be so arranged that adjacent bars in the same panel will be separated by at least 0.5 in. Ring-shaped spacers shall be provided to fill any gaps between adjacent eyebars on a pin. Intersecting diagonal bars that are not sufficiently spaced to clear each other at all times shall be clamped together at the intersection.

6.8.7—Pin-Connected Plates

6.8.7.1—General

Pin-connected plates should be avoided wherever possible.

The provisions of Article 6.8.2.1 shall be satisfied.

6.8.7.2—Pin Plates

The factored bearing resistance on pin plates, P_r , shall be taken as:

$$P_r = \phi_b P_n = \phi_b A_b F_y \quad (6.8.7.2-1)$$

where:

- P_n = nominal bearing resistance (kip)
- A_b = projected bearing area on the plate (in.²)
- F_y = specified minimum yield strength of the plate (ksi)
- ϕ_b = resistance factor for bearing specified in Article 6.5.4.2

The limitation on the hole diameter for steel with specified minimum yield strengths above 70 ksi, which is not included in the AASHTO Standard Specifications, is intended to prevent dishing beyond the pin hole (AISC, 2005).

C6.8.6.3

The eyebar assembly should be detailed to prevent corrosion-causing elements from entering the joints.

Eyebars sometimes vibrate perpendicular to their plane. The intent of this provision is to prevent repeated eyebar contact by providing adequate spacing or by clamping.

The main plate may be strengthened in the region of the hole by attaching pin plates to increase the thickness of the main plate.

If pin plates are used, they shall be arranged to minimize load eccentricity and shall be attached to the main plate by sufficient welds or bolts to transmit the bearing forces from the pin plates into the main plate.

6.8.7.3—Proportions

The combined net area of the main plate and pin plates on a transverse cross-section through the centerline of the pin hole shall not be less than 1.4 times the required net area of the main plate away from the hole.

The combined net area of the main plate and pin plates beyond the pin hole taken in a longitudinal direction shall not be less than the required net area of the main plate away from the pin hole.

The center of the pin hole shall be located on the longitudinal axis of the main plate. The pin hole diameter shall not be more than 0.03125 in. greater than the pin diameter.

For steels having a specified minimum yield strength greater than 70.0 ksi, the hole diameter shall not exceed five times the combined thickness of the main plate and pin plates.

The combined thickness of the main plate and pin plates shall not be less than 12 percent of the net width from the edge of the hole to the edge of the plate or plates. The thickness of the main plate shall not be less than 12 percent of the required width away from the hole.

6.8.7.4—Packing

Pin-connected members shall be restrained against lateral movement on the pin and against lateral distortion due to the skew of the bridge.

6.9—COMPRESSION MEMBERS

6.9.1—General

The provisions of this Article shall apply to prismatic noncomposite and composite steel members subjected to either axial compression or combined axial compression and flexure.

Arches shall also satisfy the requirements of Article 6.14.4.

Compression chords of half-through trusses shall also satisfy the requirements of Article 6.14.2.9.

C6.8.7.3

The proportions specified in this Article assure that the member will not fail in the region of the hole if the strength limit state is satisfied in the main plate away from the hole.

C6.8.7.4

The pin-connected assembly should be detailed to prevent corrosion-causing elements from entering the joints.

C6.9.1

Conventional column design formulas contain allowances for imperfections and eccentricities permissible in normal fabrication and erection. The effect of any significant additional eccentricity should be accounted for in bridge design.

6.9.2—Compressive Resistance

6.9.2.1—Axial Compression

The factored resistance of components in compression, P_r , shall be taken as:

$$P_r = \phi_c P_n \quad (6.9.2.1-1)$$

where:

P_n = nominal compressive resistance as specified in Articles 6.9.4 or 6.9.5, as applicable (kip)

ϕ_c = resistance factor for compression as specified in Article 6.5.4.2

6.9.2.2—Combined Axial Compression and Flexure

Except as permitted otherwise in Article 6.9.4.4, the axial compressive load, P_u , and concurrent moments, M_{ux} and M_{uy} , calculated for the factored loadings by elastic analytical procedures shall satisfy the following relationship:

- If $\frac{P_u}{P_r} < 0.2$, then

$$\frac{P_u}{2.0P_r} + \left(\frac{M_{ux}}{M_{rx}} + \frac{M_{uy}}{M_{ry}} \right) \leq 1.0 \quad (6.9.2.2-1)$$

- If $\frac{P_u}{P_r} \geq 0.2$, then

$$\frac{P_u}{P_r} + \frac{8.0}{9.0} \left(\frac{M_{ux}}{M_{rx}} + \frac{M_{uy}}{M_{ry}} \right) \leq 1.0 \quad (6.9.2.2-2)$$

where:

P_r = factored compressive resistance as specified in Article 6.9.2.1 (kip)

M_{rx} = factored flexural resistance about the x -axis taken equal to ϕ_f times the nominal flexural resistance about the x -axis determined as specified in Article 6.10, 6.11 or 6.12, as applicable (kip-in.)

M_{ry} = factored flexural resistance about the y -axis taken equal to ϕ_f times the nominal flexural resistance about the y -axis determined as specified in Article 6.12, as applicable (kip-in.)

M_{ux} = factored flexural moment about the x -axis calculated as specified below (kip-in.)

M_{uy} = factored flexural moment about the y -axis calculated as specified below (kip-in.)

ϕ_f = resistance factor for flexure specified in Article 6.5.4.2

C6.9.2.2

These equations are identical to Eqs. (H1-1a) and (H1-1b) of AISC (2005). They were selected for use in that Specification after being compared with a number of alternative formulations with the results of refined inelastic analyses of 82 frame sidesway cases (Kanchanalai, 1977). P_u , M_{ux} , and M_{uy} are simultaneous axial and flexural forces on cross-sections determined by analysis under factored loads. The maximum calculated moment in the member in each direction including the second-order effects, should be considered. Where maxima occur on different cross-sections, each should be checked.

For further information on computing the factored flexural resistances about the x - and y -axes, refer to Article C6.8.2.3.

For tees and double angles subject to combined axial compression and flexure in which the axial and flexural stresses in the flange of the tee or the connected legs of the angles are additive in compression, e.g., when a tee is used as a bracing member and the connection of this member is made to the flange, a bulge in the interaction curve occurs. As a result, Eqs. 6.9.2.2-1 and 6.9.2.2-2 may significantly underestimate the resistance in such cases. Alternative approaches attempting to capture this bulge have proven to be generally inconclusive or incomplete as of this writing (2009). In the interim, it is recommended that Eqs. 6.9.2.2-1 and 6.9.2.2-2 be conservatively applied to these cases. Should significant additional resistance be required, the use of one or more of these alternative approaches, as described in White (2006), may be considered.

M_{ux} and M_{uy} , moments about axes of symmetry, may be determined by:

- A second-order elastic analysis that accounts for the magnification of moment caused by the factored axial load, or
- The approximate single step adjustment specified in Article 4.5.3.2.2b.

6.9.3—Limiting Slenderness Ratio

Compression members shall satisfy the slenderness requirements specified herein.

- For primary members: $\frac{K\ell}{r} \leq 120$
- For secondary members: $\frac{K\ell}{r} \leq 140$

where:

K = effective length factor specified in Article 4.6.2.5

ℓ = unbraced length (in.)

r = radius of gyration (in.)

For the purpose of this Article only, the radius of gyration may be computed on a notional section that neglects part of the area of a component, provided that:

- The capacity of the component based on the actual area and radius of gyration exceeds the factored loads, and
- The capacity of the notional component based on a reduced area and corresponding radius of gyration also exceeds the factored loads.

6.9.4—Noncomposite Members

6.9.4.1—Nominal Compressive Resistance

6.9.4.1.1—General

The nominal compressive resistance, P_n , shall be taken as the smallest value based on the applicable modes of flexural buckling, torsional buckling, and flexural-torsional buckling as follows:

- Applicable buckling modes for doubly symmetric members:
 - Flexural buckling shall be applicable. Torsional buckling shall also be applicable for open-section members in which the effective torsional unbraced length is larger than the effective lateral unbraced length.

C6.9.4.1

C6.9.4.1.1

Eqs. 6.9.4.1.1-1 and 6.9.4.1.1-2 are equivalent to the equations given in AISC (2005) for computing the nominal compressive resistance. The equations are written in a different format in terms of the critical elastic buckling resistance, P_e , and the equivalent nominal yield resistance, P_o , to allow for more convenient calculation of the nominal resistance for members subject to buckling modes in addition to, or other than, flexural buckling, and to allow for the consideration of compression members with slender elements, as defined below. Also, this form of the resistance equations may be used to conveniently calculate P_n when a refined buckling analysis is employed to assess the stability of trusses, frames or arches in lieu of utilizing

- Applicable buckling modes for singly symmetric members:
 - Flexural buckling shall be applicable.
 - Flexural-torsional buckling shall also be applicable for open-section members.
- Applicable buckling modes for unsymmetric members:
 - Only flexural-torsional buckling shall be applicable for open-section members, except that for single-angle members designed according to the provisions of Article 6.9.4.4, only flexural buckling shall be applicable.
 - Only flexural buckling shall be applicable for closed-section members.

Torsional buckling and flexural-torsional buckling shall not be applicable for bearing stiffeners.

P_n shall be determined as follows:

- If $\frac{P_e}{P_o} \geq 0.44$, then:

$$P_n = \left[0.658 \left(\frac{P_o}{P_e} \right) \right] P_o \quad (6.9.4.1.1-1)$$

- If $\frac{P_e}{P_o} < 0.44$, then:

$$P_n = 0.877 P_e \quad (6.9.4.1.1-2)$$

where:

- A_g = gross cross-sectional area of the member (in.²)
- F_y = specified minimum yield strength (ksi)
- P_e = elastic critical buckling resistance determined as specified in Article 6.9.4.1.2 for flexural buckling, and as specified in Article 6.9.4.1.3 for torsional buckling or flexural-torsional buckling, as applicable (kips)
- P_o = equivalent nominal yield resistance = QF_yA_g (kips)
- Q = slender element reduction factor determined as specified in Article 6.9.4.2. Q shall be taken equal to 1.0 for bearing stiffeners.

Table 6.9.4.1.1-1 may be used for guidance in selecting the appropriate potential buckling mode(s) to be considered in the determination of P_n , and the equations to use for the calculation of P_e and Q , as applicable.

an effective length factor approach (White, 2006). In such cases, P_e in Eqs. 6.9.4.1.1-1 and 6.9.4.1.1-2 would be taken as the axial load in a given member taken from the analysis at incipient elastic buckling of the structure or subassembly.

Eqs. 6.9.4.1.1-1 and 6.9.4.1.1-2 represent a curve that is essentially the same as column strength curve $2P$ of Galambos (1998). The equations incorporate an out-of-straightness criterion of $L/1500$. The development of the mathematical form of these equations is described in Tide (1985), and the structural reliability they are intended to provide is discussed in Galambos (1998) and Galambos (2006).

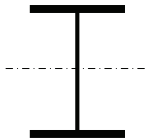
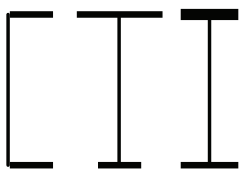
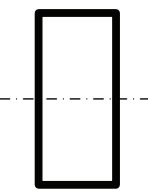
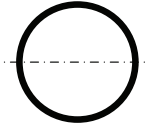
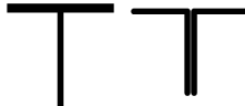

For the member under consideration, Table 6.9.4.1.1-1 may be used as a guideline for selecting the appropriate potential buckling mode(s) to be considered in the determination of P_n , and the equations to use for the calculation of the corresponding critical elastic buckling resistance, P_e , and slender element reduction factor, Q , as applicable. For compression members with cross-sections composed of one or more slender elements, or elements not meeting the corresponding width-to-thickness ratio limits specified in Article 6.9.4.2.1, the slender element reduction factor Q accounts for the effect of potential local buckling of those elements on the overall buckling resistance of the member and has a value less than 1.0. The value of Q in this instance is determined according to the provisions of Article 6.9.4.2.2. For compression member cross-sections without any slender elements, that is, composed entirely of non-slender elements, Q is taken equal to 1.0 as specified in Article 6.9.4.2.1. Q is always to be taken equal to 1.0 for bearing stiffeners.

Table 6.9.4.1.1-1—Selection Table for Determination of Nominal Compressive Resistance, P_n

Cross-Section	Without Slender Elements ($Q = 1.0$)		With Slender Elements ($Q < 1.0$)	
	Potential Buckling Mode	Applicable Equation for P_e	Potential Buckling Mode	Applicable Equations for P_e and Q
	FB	(6.9.4.1.2-1)	FB	(6.9.4.1.2-1)
	and if $K_z \ell_z > K_y \ell_y$: TB	(6.9.4.1.3-1) Note: see also Article C6.9.4.1.3	and if $K_z \ell_z > K_y \ell_y$: TB	(6.9.4.1.3-1) Note: see also Article C6.9.4.1.3
			and: FLB	(6.9.4.2.2-1) or (6.9.4.2.2-2) or (6.9.4.2.2-7) or (6.9.4.2.2-8)
			and/or: WLB	(6.9.4.2.2-11)
	FB	(6.9.4.1.2-1)	FB	(6.9.4.1.2-1)
	and: FTB	(6.9.4.1.3-2) Note: see also Article C6.9.4.1.3	and: FTB	(6.9.4.1.3-2) Note: see also Article C6.9.4.1.3
			and: FLB	(6.9.4.2.2-1) or (6.9.4.2.2-2) or (6.9.4.2.2-7) or (6.9.4.2.2-8)
			and/or: WLB	(6.9.4.2.2-11)
	FB	(6.9.4.1.2-1) Note: for built-up sections, see also Article 6.9.4.3	FB	(6.9.4.1.2-1) Note: for built-up sections, see also Article 6.9.4.3
			and: FLB	(6.9.4.2.2-10) or (6.9.4.2.2-11)
			and/or: WLB	(6.9.4.2.2-11)
	FB	(6.9.4.1.2-1)	FB	(6.9.4.1.2-1)
			and: LB	(6.9.4.2.2-12)
	FB	(6.9.4.1.2-1)	FB	(6.9.4.1.2-1)
	and: FTB	(6.9.4.1.3-2) Note: see also Article C6.9.4.1.3	and: FTB	(6.9.4.1.3-2) Note: see also Article C6.9.4.1.3
			Tees	(6.9.4.2.2-1) or (6.9.4.2.2-2) or (6.9.4.2.2-7) or (6.9.4.2.2-8)
			and: FLB	(6.9.4.2.2-3) or (6.4.4.2.2-4)
			and/or: SLB	(6.4.4.2.2-4)

continued on next page

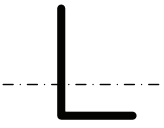
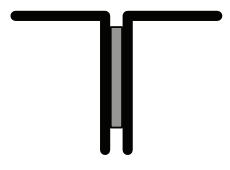
Table 6.9.4.1.1-1 (continued)—Selection Table for Determination of Nominal Compressive Resistance, P_n

Cross-Section	Without Slender Elements ($Q = 1.0$)		With Slender Elements ($Q < 1.0$)	
	Potential Buckling Mode	Applicable Equation for P_e	Potential Buckling Mode	Applicable Equations for P_e and Q
			Double Angles in Continuous Contact and: LLB	(6.9.4.2.2-1) or (6.4.4.2.2-2)
	FB	(6.9.4.1.2-1) Note: see also Articles 6.9.4.4 and C6.9.4.4	FB and: LLB	(6.9.4.1.2-1) Note: see also Articles 6.9.4.4 and C6.9.4.4 (6.9.4.2.2-5) or (6.9.4.2.2-6)
	FB	(6.9.4.1.2-1) Note: see also Article 6.9.4.3	Double Angles with Separators FB	(6.9.4.1.2-1) Note: see also Article 6.9.4.3
	and: FTB	(6.9.4.1.3-2) Note: see also Article C6.9.4.1.3	and: FTB	(6.9.4.1.3-2) Note: see also Article C6.9.4.1.3
			and: LLB	(6.9.4.2.2-5) or (6.9.4.2.2-6)
	FB	(6.9.4.1.2-1)	NA	NA
Unsymmetric Open-Sections	FTB	(6.9.4.1.3-3) Note: see also Article C6.9.4.1.3	FTB	(6.9.4.1.3-3) Note: see also Article C6.9.4.1.3
			and: LB	See Article 6.9.4.2.2
Unsymmetric Closed-Sections	FB	(6.9.4.1.2-1)	FB	(6.9.4.1.2-1)
			and: LB	See Article 6.9.4.2.2
Bearing Stiffeners	FB	(6.9.4.1.2-1) Note: See also Article 6.10.11.2.4	NA	NA
where:				
FB = flexural buckling				
TB = torsional buckling				
FTB = flexural-torsional buckling				
FLB = flange local buckling				
WLB = web local buckling				
SLB = stem local buckling				
LLB = outstanding leg local buckling				
LB = local buckling				
NA = not applicable				

6.9.4.1.2—Elastic Flexural Buckling Resistance

The elastic critical buckling resistance, P_e , based on flexural buckling shall be taken as:

$$P_e = \frac{\pi^2 E}{\left(\frac{K \ell}{r_s}\right)^2} A_g \quad (6.9.4.1.2-1)$$

where:

- A_g = gross cross-sectional area of the member (in.²)
- K = effective length factor in the plane of buckling determined as specified in Article 4.6.2.5
- ℓ = unbraced length in the plane of buckling (in.)
- r_s = radius of gyration about the axis normal to the plane of buckling (in.)

6.9.4.1.3—Elastic Torsional Buckling and Flexural-Torsional Buckling Resistance

For open-section doubly symmetric members, the elastic critical buckling resistance, P_e , based on torsional buckling shall be taken as:

$$P_e = \left[\frac{\pi^2 E C_w}{(K_z \ell_z)^2} + GJ \right] \frac{A_g}{I_x + I_y} \quad (6.9.4.1.3-1)$$

where:

- A_g = gross cross-sectional area of the member (in.²)
- C_w = warping torsional constant (in.⁶)
- G = shear modulus of elasticity for steel = $0.385E$ (ksi)
- I_x, I_y = moments of inertia about the major and minor principal axes of the cross-section, respectively (in.⁴)
- J = St. Venant torsional constant (in.⁴)
- $K_z \ell_z$ = effective length for torsional buckling (in.)

For open-section singly symmetric members where y is the axis of symmetry of the cross-section, the elastic critical buckling resistance, P_e , based on flexural-torsional buckling shall be taken as:

$$P_e = \left(\frac{P_{ey} + P_{ez}}{2H} \right) \left[1 - \sqrt{1 - \frac{4P_{ey}P_{ez}H}{(P_{ey} + P_{ez})^2}} \right] \quad (6.9.4.1.3-2)$$

in which:

C6.9.4.1.2

Flexural buckling of concentrically loaded compression members refers to a buckling mode in which the member deflects laterally without twist or a change in the cross-sectional shape. Flexural buckling involves lateral displacements of the member cross-sections in the direction of the x - or y -axes that are resisted by the respective flexural rigidities, EI_x or EI_y , of the member.

Eq. 6.9.4.1.2-1 should be used to calculate the critical flexural buckling resistances about the x - and y -axes, with the smaller value taken as P_e for use in Eq. 6.9.4.1.1-1 or 6.9.4.1.1-2, as applicable.

C6.9.4.1.3

Torsional buckling of concentrically loaded compression members refers to a buckling mode in which the member twists about its shear center. Torsional buckling applies only for open-section doubly symmetric compression members for which the locations of the centroid and shear center coincide. Torsional buckling will rarely control and need not be considered for doubly symmetric I-section members satisfying the cross-section proportion limits specified in Article 6.10.2, unless the effective length for torsional buckling is significantly larger than the effective length for y -axis flexural buckling. The effective length for torsional buckling, $K_z \ell_z$, is typically taken as the length between locations where the member is prevented from twisting. That is, in many cases, $K_z \ell_z$ can be taken conservatively as $1.0 \ell_z$. For a cantilever member fully restrained against twisting and warping at one end with the other end free, $K_z \ell_z$ should be taken as 2ℓ where ℓ is the length of the member (White, 2006). For a member with twisting and warping restrained at both ends, $K_z \ell_z$ may be taken as 0.5ℓ . For a doubly symmetric I-section, C_w may be taken as $I_y h^2/4$, where h is the distance between flange centroids, in lieu of a more precise analysis. For closed sections, C_w may be taken equal to zero and GJ is relatively large. Because of the large GJ , torsional buckling and flexural-torsional buckling need not be considered for built-up members composed of closed sections.

Flexural-torsional buckling of concentrically loaded compression members refers to a buckling mode in which the member twists and bends simultaneously without a change in the cross-sectional shape. Compression members composed of open singly symmetric cross-sections, where

$$H = 1 - \frac{y_o^2}{\bar{r}_o^2} \quad (6.9.4.1.3-3)$$

$$P_{ey} = \frac{\pi^2 E}{\left(\frac{K_y \ell_y}{r_y}\right)^2} A_g \quad (6.9.4.1.3-4)$$

$$P_{ez} = \left(\frac{\pi^2 EC_w}{(K_z \ell_z)^2} + GJ \right) \frac{1}{\bar{r}_o^2} \quad (6.9.4.1.3-5)$$

$$\bar{r}_o^2 = y_o^2 + \frac{I_x + I_y}{A_g} \quad (6.9.4.1.3-6)$$

where:

- $K_y \ell_y$ = effective length for flexural buckling about the y -axis (in.)
 \bar{r}_o = polar radius of gyration about the shear center (in.)
 r_y = radius of gyration about the y -axis (in.)
 y_o = distance along the y -axis between the shear center and centroid of the cross-section (in.)

For open-section unsymmetric members, the elastic critical buckling resistance, P_e , based on flexural-torsional buckling shall be taken as the lowest root of the following cubic equation:

$$\begin{aligned} (P_e - P_{ex})(P_e - P_{ey})(P_e - P_{ez}) - P_e^2 (P_e - P_{ey}) \left(\frac{x_o}{r_o}\right)^2 \\ - P_e^2 (P_e - P_{ex}) \left(\frac{y_o}{r_o}\right)^2 = 0 \end{aligned} \quad (6.9.4.1.3-7)$$

in which:

$$P_{ex} = \frac{\pi^2 E}{\left(\frac{K_x \ell_x}{r_x}\right)^2} A_g \quad (6.9.4.1.3-8)$$

$$\bar{r}_o^2 = x_o^2 + y_o^2 + \frac{I_x + I_y}{A_g} \quad (6.9.4.1.3-9)$$

where:

- $K_x \ell_x$ = effective length for flexural buckling about the x -axis (in.)

the y -axis is defined as the axis of symmetry of the cross-section, can fail either by flexural buckling about the x -axis or by torsion combined with flexure about the y -axis. Compression members composed of open unsymmetric cross-sections, or members with no cross-section axis of symmetry, fail by torsion combined with flexure about the x - and y -axes. In both of the preceding cases, the centroid and shear center of the cross-section do not coincide. As buckling occurs, the axial load has a lateral component resulting from the lateral deflection of the member. This lateral component, acting about the shear center of the cross-section, causes simultaneous twisting of the member. The degree of interaction between the torsional and flexural deformations determines the reduction of this buckling load in comparison to the flexural buckling load (Galambos, 1998). As the distance between the centroid and shear center increases, the twisting tendency increases and the flexural-torsional buckling load decreases. Flexural-torsional buckling may be a critical mode of failure for thin-walled open-section singly symmetric compression members, e.g. tees, double angles, and channels, and for open-section unsymmetric compression members due to their relatively low torsional rigidity. For open-section singly symmetric members, the critical flexural-torsional buckling resistance is always smaller than the critical flexural buckling resistance about the y -axis, P_{ey} . Therefore, in such cases, only flexural buckling about the x -axis need be considered along with flexural-torsional buckling. For open-section unsymmetric members, except for single-angle members designed according to the provisions of Article 6.9.4.4, only flexural-torsional buckling is considered; flexural buckling about the x - and y -axes need not be checked. Single-angle members designed according to the provisions of Article 6.9.4.4 need only be checked for flexural buckling; flexural-torsional buckling need not be considered (AISC, 2005).

Eqs. 6.9.4.1.3-2 through 6.9.4.1.3-6 assume that the y -axis is defined as the axis of symmetry of the cross-section. Therefore, for a channel, the y -axis should actually be taken as the x -axis of the cross-section, or the axis of symmetry for the channel section, when applying these equations. C_w should conservatively be taken equal to zero for tees and double angles in the application of these equations. Refer to Article C6.12.2.2.4 for additional information on the calculation of the St. Venant torsional constant J for tees and double angles. For channels, refer to Article C6.12.2.2.5 for additional information on the calculation of C_w and J .

For singly symmetric I-section compression members with equal flange widths and differing flange thicknesses, flexural-torsional buckling need not be considered as long as $0.67 \leq t_{f1}/t_{f2} \leq 1.5$ and $K_z \ell_z \leq K_y \ell_y$, where t_{f1} and t_{f2} are the flange thicknesses and K_z and K_y are the effective length factors for torsional buckling and for flexural buckling about the y -axis, respectively (White, 2006). However, flexural-torsional buckling should always be checked for singly symmetric I-sections that are loaded in

r_x = radius of gyration about the x -axis (in.)
 x_o = distance along the x -axis between the shear center and centroid of the cross-section (in.)

axial compression when the flange widths are different. C_w may be computed as follows for such sections in lieu of a more precise analysis (Salmon and Johnson, 1996):

$$C_w = \frac{t_f h^2}{12} \left(\frac{b_1^3 b_2^3}{b_1^3 + b_2^3} \right) \quad (C6.9.4.1.3-1)$$

where:

b_1, b_2 = individual flange widths (in.)
 h = distance between flange centroids (in.)
 t_f = flange thickness (in.) Use an average thickness if the flange thicknesses differ.

6.9.4.2—Nonslender and Slender Member Elements

C6.9.4.2

6.9.4.2.1—Nonslender Member Elements

C6.9.4.2.1

Nonslender member elements shall satisfy the slenderness limits specified herein. The slender element reduction factor, Q , specified in Article 6.9.4.1.1 shall be taken as 1.0 for compression member cross-sections composed entirely of nonslender elements.

Unless otherwise specified herein, the slenderness of plates shall satisfy:

$$\frac{b}{t} \leq k \sqrt{\frac{E}{F_y}} \quad (6.9.4.2.1-1)$$

where:

k = plate buckling coefficient as specified in Table 6.9.4.2.1-1
 b = width of plate as specified in Table 6.9.4.2.1-1 (in.)
 t = plate thickness (in.). For flanges of rolled channels, use the average thickness.

Flanges of built-up I-sections, and plates or angle legs projecting from built-up I-sections, shall satisfy:

$$\frac{b}{t} \leq 0.64 \sqrt{\frac{k_c E}{F_y}} \quad (6.9.4.2.1-2)$$

and:

$$0.35 \leq k_c \leq 0.76 \quad (6.9.4.2.1-3)$$

in which:

Nonslender member elements satisfying the width-to-thickness ratio limits specified herein are able to develop their full nominal yield strength under uniform axial compression before the onset of local buckling. For compression member cross-sections composed entirely of nonslender elements, local buckling does not adversely affect the nominal compressive resistance; therefore, a reduction in the resistance is not necessary and the slender element reduction factor, Q , in Article 6.9.4.1.1 is taken equal to 1.0. These limits do not apply when determining the nominal resistance of flexural members for which compression flange and web elements may need to withstand larger inelastic strains in order to ensure that local buckling does not adversely affect the calculated resistance. For such cases, the more stringent width-to-thickness requirements of the applicable portions of Articles 6.10, 6.11 and 6.12 apply.

In Table 6.9.4.2.1-1, plates supported along one edge parallel to the direction of the compression force are identified as unstiffened elements, and plates supported along two edges parallel to the direction of the force are identified as stiffened elements.

The form of the width-to-thickness equations derives from the classical elastic critical stress formula for plates: $F_{cr} = [\pi^2 k E] / [12(1-\mu^2)(b/t)^2]$, in which the buckling coefficient, k , is a function of loading and support conditions. For a long, uniformly compressed plate with one longitudinal edge simply-supported against rotation and the other free, $k = 0.425$, and for both edges simply-supported, $k = 4.00$ (Timoshenko and Gere, 1961). For these conditions, the coefficients of the b/t equation become 0.620 and 1.901, respectively. The coefficients specified herein are the result of further analyses and numerous tests and reflect the effect of residual stresses,

$$k_c = \frac{4}{\sqrt{\frac{D}{t_w}}} \quad (6.9.4.2.1-4)$$

where:

- b = half-width of flange (in.)
 D = web depth (in.)

Wall thickness of circular tubes, including round HSS, shall satisfy:

$$\frac{D}{t} \leq 0.11 \frac{E}{F_y} \quad (6.9.4.2.1-5)$$

where:

- D = outside diameter of tube (in.)
 t = thickness of tube (in.)

For members designed for combined axial compression and flexure, F_y , as used herein, may be replaced with the maximum calculated compressive stress due to the factored axial load and concurrent bending moment provided that the interaction relationships of Article 6.9.2.2 are replaced by the following linear relationship:

$$\frac{P_u}{P_r} + \frac{M_{ux}}{M_{rx}} + \frac{M_{uy}}{M_{ry}} \leq 1.0 \quad (6.9.4.2.1-6)$$

where:

- P_r = factored compressive resistance determined as specified in Article 6.9.2.1 (kip)
 P_u = axial compressive force effect resulting from factored loads (kip)
 M_{rx} = factored flexural resistance about the x -axis taken equal to ϕ_f times the nominal flexural resistance about the x -axis determined as specified in Article 6.10, 6.11 or 6.12, as applicable (kip-in.)
 M_{ry} = factored flexural resistance about the y -axis taken equal to ϕ_f times the nominal flexural resistance about the y -axis determined as specified in Article 6.12, as applicable (kip-in.)
 M_{ux} = flexural moment about the x -axis resulting from factored loads (kip-in.)
 M_{uy} = flexural moment about the y -axis resulting from factored loads (kip-in.)

initial imperfections, and actual (as opposed to ideal) support conditions.

For projecting flanges of built-up I-sections under axial compression, web-flange interaction is considered. Theory indicates that the web-flange interaction for built-up I-sections under axial compression is at least as severe as for flexure. The k_c factor accounts for the interaction of flange and web local buckling demonstrated in experiments conducted by Johnson (1985). For built-up sections with $D/t_w \geq 130.6$, k_c may be taken equal to 0.35. For smaller values of D/t_w , k_c increases from 0.35 up to a maximum value of 0.76 as a function of the web slenderness D/t_w . A k_c value of 0.76 yields a k value of 0.56. Rolled I-sections are excluded from this criteria because web-flange interaction effects are considered negligible for these sections.

The local buckling resistance of circular tubes, including round Hollow Structural Sections (HSS), is significantly overestimated by the classical theory for longitudinally compressed cylinders due to imperfections of shape and eccentricities of the load. Therefore, the limit given by Eq. 6.9.4.2.1-5 to prevent local buckling of circular tubes is based on test results (Sherman, 1976) rather than theoretical calculations. When D/t exceeds the value given by Eq. 6.9.4.2.1-5, Eq. 6.9.4.2.2-12 should be used to compute the local buckling reduction factor, Q_a . This equation is valid up to a D/t limit of $0.45E/F_y$. Circular tubes with D/t values greater than this limit are not recommended for use as compression members. Circular tubes or pipes may be designed using the provisions specified herein for round Hollow Structural Sections (HSS) provided that they conform to ASTM A53, Class B and the appropriate parameters are used in the design. Additional information on connection design for round, square, and rectangular HSS may be found in Chapter K of AISC (2005).

Eq. 6.9.4.2.1-6 is used if F_y is replaced with the maximum calculated compressive stress due to the factored axial load and concurrent bending moment in checking the slenderness limits for non-slender member elements since the bilinear interaction relationships of Article 6.9.2.2 are not valid if the non-slender member element limits are modified in this fashion.

6.9.4.2.1-1—Plate Buckling Coefficients and Width of Plates for Axial Compression

Plates Supported along One Edge (Unstiffened Elements)	k	b
Flanges of Rolled I-, Tee, and Channel Sections; Plates Projecting from Rolled I-Sections; and Outstanding Legs of Double Angles in Continuous Contact	0.56	• Half-flange width of rolled I- and tee sections
		• Full-flange width of channel sections
		• Distance between free edge and first line of bolts or welds in plates
		• Full width of an outstanding leg for double angles in continuous contact
Stems of Rolled Tees	0.75	• Full depth of tee
Outstanding Legs of Single Angles; Outstanding Legs of Double Angles with Separators; and All Other Unstiffened Elements	0.45	• Full width of outstanding leg for single angle or double angles with separators
		• Full projecting width for all others
Plates Supported Along Two Edges (Stiffened Elements)	k	b
Flanges and Webs of Square and Rectangular Built-Up Box Sections and HSS; and Nonperforated Flange Cover Plates	1.40	• Distance between adjacent lines of bolts or welds in flanges of built-up box sections
		• Distance between adjacent lines of bolts or clear distance between flanges when welds are used in webs of built-up box sections
		• Clear distance between webs or flanges minus inside corner radius on each side for HSS. Use the outside dimension minus three times the appropriate design wall thickness specified in Article 6.12.2.2.2 if the corner radius is not known
		• Distance between lines of welds or bolts for flange cover plates
Webs of I- and Channel Sections; and All Other Stiffened Elements	1.49	• Clear distance between flanges minus the fillet or corner radius at each flange for webs of rolled I- and channel sections
		• Distance between adjacent lines of bolts or clear distance between flanges when welds are used for webs of built-up I- and channel sections
		• Clear distance between edge supports for all others
Perforated Cover Plates	1.86	• Clear distance between edge supports; see also the paragraph at the end of Article 6.9.4.3.2

6.9.4.2.2—Slender Member Elements

C6.9.4.2.2

Member elements not satisfying the slenderness limits specified in Article 6.9.4.2.1 shall be classified as slender elements and shall be subject to the requirements specified herein.

For compression member cross-sections composed of only unstiffened slender elements, the slender element reduction factor, Q , specified in Article 6.9.4.1.1 shall be taken equal to the factor for unstiffened elements, Q_s . Q_s shall be taken as the smallest value for all the unstiffened slender elements in the cross-section. For compression member cross-sections composed of only stiffened slender elements, Q shall be taken equal to the factor for stiffened elements, Q_a . For compression member cross-sections composed of both unstiffened and stiffened slender elements, Q shall be taken equal to the product of Q_s and Q_a .

For unstiffened slender elements, Q_s shall be taken as:

- For flanges of rolled I-, tee and channel sections; plates projecting from rolled I-sections; and outstanding legs of pairs of angles in continuous contact:

- If $0.56\sqrt{\frac{E}{F_y}} < \frac{b}{t} \leq 1.03\sqrt{\frac{E}{F_y}}$, then:

$$Q_s = 1.415 - 0.74\left(\frac{b}{t}\right)\sqrt{\frac{F_y}{E}} \quad (6.9.4.2.2-1)$$

- If $\frac{b}{t} > 1.03\sqrt{\frac{E}{F_y}}$, then:

$$Q_s = \frac{0.69E}{F_y\left(\frac{b}{t}\right)^2} \quad (6.9.4.2.2-2)$$

- For stems of rolled tees:

- If $0.75\sqrt{\frac{E}{F_y}} < \frac{b}{t} \leq 1.03\sqrt{\frac{E}{F_y}}$, then:

$$Q_s = 1.908 - 1.22\left(\frac{b}{t}\right)\sqrt{\frac{F_y}{E}} \quad (6.9.4.2.2-3)$$

For compression members with cross-sections composed of one or more slender elements, or elements not meeting the corresponding width-to-thickness ratio limits specified in Article 6.9.4.2.1, potential local buckling of those elements may adversely affect the overall buckling resistance of the member. Hence, the nominal compressive resistance, P_n , based on flexural, torsional or flexural-torsional buckling, as applicable, must be reduced. Rolled wide-flange sections with ratios of $d/b_f \geq 1.7$, where d is the section depth and b_f is the flange width, typically have slender webs for uniform axial compression. Webs of welded I- and box sections also typically classify as slender elements for axial compression according to these criteria. The stems of a significant number of rolled tee sections and one or both legs of many rolled angle sections must be classified as slender elements.

For compression members containing slender elements, P_n in Article 6.9.4.1.1 is calculated using a reduced equivalent nominal yield resistance, $P_o = QF_yA_g$, where A_g is the gross cross-sectional area of the member and the slender element reduction factor, Q , is less than 1.0. An equivalent approach is followed in AISC (2005). These procedures emulate the approach originally specified in AISI (1969). In calculating Q as specified herein, a distinction is made between unstiffened and stiffened elements as defined in Article C6.9.4.2.1.

Unstiffened slender elements are assumed to reach their limit of resistance when they attain their theoretical local buckling resistance. The slender element reduction factor, Q_s , for slender unstiffened elements is equal to the ratio of the smallest local buckling resistance of all the unstiffened elements in the cross-section divided by F_y . That is, for a compression member composed entirely of unstiffened elements, the reduced equivalent nominal yield strength of the member is taken as the average axial stress at which the most critical unstiffened element reaches its local buckling resistance.

Stiffened slender elements utilize the post-buckling resistance that is available to a plate supported along two longitudinal edges. An effective width approach is used to determine the available post-buckling resistance. The slender element reduction factor, Q_a , for slender stiffened elements given by Eq. 6.9.4.2.2-9 is based on an effective cross-sectional area, which is calculated based on the effective widths, b_e , for all the stiffened slender elements within the cross-section. b_e represents the total width of the two rectangular stress blocks at each longitudinal edge over which the maximum stress, f , at each edge can be assumed to act uniformly to produce the same force as the actual stresses acting over the full width of the plate. The actual average stresses in the middle of the plate, averaged through the thickness, are smaller due to the post-buckling

- If $\frac{b}{t} > 1.03 \sqrt{\frac{E}{F_y}}$, then:

$$Q_s = \frac{0.69E}{F_y \left(\frac{b}{t}\right)^2} \quad (6.9.4.2.2-4)$$

- For outstanding legs of single angles; outstanding legs of double angles with separators; and all other unstiffened elements:

- If $0.45 \sqrt{\frac{E}{F_y}} < \frac{b}{t} \leq 0.91 \sqrt{\frac{E}{F_y}}$, then:

$$Q_s = 1.34 - 0.76 \left(\frac{b}{t}\right) \sqrt{\frac{F_y}{E}} \quad (6.9.4.2.2-5)$$

- If $\frac{b}{t} > 0.91 \sqrt{\frac{E}{F_y}}$, then:

$$Q_s = \frac{0.53E}{F_y \left(\frac{b}{t}\right)^2} \quad (6.9.4.2.2-6)$$

- For flanges of built-up I-sections; and plates or angle legs projecting from built-up I-sections:

- If $0.64 \sqrt{\frac{k_c E}{F_y}} < \frac{b}{t} \leq 1.17 \sqrt{\frac{k_c E}{F_y}}$, then:

$$Q_s = 1.415 - 0.65 \left(\frac{b}{t}\right) \sqrt{\frac{F_y}{k_c E}} \quad (6.9.4.2.2-7)$$

- If $\frac{b}{t} > 1.17 \sqrt{\frac{k_c E}{F_y}}$, then:

$$Q_s = \frac{0.90 k_c E}{F_y \left(\frac{b}{t}\right)^2} \quad (6.9.4.2.2-8)$$

For stiffened slender elements, except circular tubes and round HSS, Q_a shall be taken as:

$$Q_a = \frac{A_{eff}}{A} \quad (6.9.4.2.2-9)$$

deformations. The stress, f , is simply taken as $Q_s F_y$ in Eqs. 6.9.4.2.2-10 and 6.9.4.2.2-11, in lieu of the values specified in AISC (2005), as this is felt to be a more representative calculation of the true resistance in all cases (White et al., 2006).

Additional information of the development of the equations for Q_s and Q_a may be found in the Commentary to Section E7 of AISC (2005) and in White (2006). White (2006) also provides recommendations for the application of the equations contained herein to hybrid I-sections with slender web elements subject to axial compression.

where:

A = total gross cross-sectional area of the member (in.²)

A_{eff} = summation of the effective areas of the cross-section based on a reduced effective width for each slender stiffened element in the cross-section = $A - \sum (b - b_e) t$ (in.²)

The effective width, b_e , shall be determined as follows:

- For flanges of square and rectangular box sections and HSS of uniform thickness; and nonperforated cover plates:

$$b_e = 1.92t \sqrt{\frac{E}{f}} \left[1 - \frac{0.38}{(b/t)} \sqrt{\frac{E}{f}} \right] \leq b \quad (6.9.4.2.2-10)$$

- For webs; perforated cover plates; and all other stiffened elements:

$$b_e = 1.92t \sqrt{\frac{E}{f}} \left[1 - \frac{0.34}{(b/t)} \sqrt{\frac{E}{f}} \right] \leq b \quad (6.9.4.2.2-11)$$

where:

f = $Q_s F_y$ (ksi)

Where all unstiffened elements, if any, in the cross-section are classified as nonslender, $Q_s = 1.0$.

For circular tubes, including round HSS, with D/t not exceeding $0.45 E/F_y$, Q_a shall be taken as:

$$Q_a = \frac{0.038E}{F_y(D/t)} + \frac{2}{3} \quad (6.9.4.2.2-12)$$

In the above, b , D , t , and k_c shall be taken as defined in Article 6.9.4.2.1 for the member element under consideration.

6.9.4.3—Built-up Members

6.9.4.3.1—General

The provisions of Article 6.9.4.2 shall apply. For built-up members composed of two or more shapes, the slenderness ratio of each component shape between connecting fasteners or welds shall not be more than 75 percent of the governing slenderness ratio of the built-up member. The least radius of gyration shall be used in computing the slenderness ratio of each component shape between the connectors.

C6.9.4.3.1

Two types of built-up members are commonly used for steel bridge construction: closely spaced steel shapes interconnected at intervals using welds or fasteners, and laced or battened members with widely spaced flange components.

The compressive resistance of built-up members is affected by the interaction between the global buckling mode of the member and the localized component buckling mode between lacing points or intermediate connectors.

Lacing, including flat bars, angles, channels, or other shapes employed as lacing, or batten plates shall be spaced so that the slenderness ratio of each component shape between the connectors shall not be more than 75 percent of the governing slenderness ratio of the built-up member.

The nominal compressive resistance of built-up members composed of two or more shapes shall be determined as specified in Article 6.9.4.1 subject to the following modification. If the buckling mode involves relative deformations that produce shear forces in the connectors between individual shapes, $K\ell/r$ shall be replaced by $(K\ell/r)_m$ determined as follows for intermediate connectors that are welded or fully-tensioned bolted:

$$\left(\frac{K\ell}{r}\right)_m = \sqrt{\left(\frac{K\ell}{r}\right)_o^2 + 0.82\left(\frac{\alpha^2}{1+\alpha^2}\right)\left(\frac{a}{r_{ib}}\right)^2} \quad (6.9.4.3.1-1)$$

where:

$\left(\frac{K\ell}{r}\right)_m$ = modified slenderness ratio of the built-up member

$\left(\frac{K\ell}{r}\right)_o$ = slenderness ratio of the built-up member acting as a unit in the buckling direction being considered

= separation ratio = $h/2r_{ib}$

a = distance between connectors (in.)

r_{ib} = radius of gyration of an individual component shape relative to its centroidal axis parallel to the member axis of buckling (in.)

h = distance between centroids of individual component shapes perpendicular to the member axis of buckling (in.)

6.9.4.3.2—Perforated Plates

Perforated plates shall satisfy the requirements of Articles 6.9.4.2 and 6.8.5.2 and shall be designed for the sum of the shear force due to the factored loads and an additional shear force taken as:

$$V = \frac{P_r}{100} \left(\frac{100}{(\ell/r) + 10} + \frac{8.8(\ell/r)F_y}{E} \right) \quad (6.9.4.3.2-1)$$

where:

V = additional shear force (kip)

P_r = factored compressive resistance specified in Articles 6.9.2.1 or 6.9.2.2 (kip)

ℓ = member length (in.)

r = radius of gyration about an axis perpendicular to the perforated plate (in.)

Duan, Reno, and Uang (2002) refer to this type of buckling as compound buckling. For both types of built-up members, limiting the slenderness ratio of each component shape between connection fasteners or welds or between lacing points, as applicable, to 75 percent of the governing global slenderness ratio of the built-up member effectively mitigates the effect of compound buckling (Duan, Reno, and Uang, 2002).

The compressive resistance of both types of members is also affected by any relative deformation that produces shear forces in the connectors between the individual shapes. Eq. 6.9.4.3.1-1 is adopted from AISC (2005) and provides a modified slenderness ratio taking into account the effect of the shear forces. Eq. 6.9.4.3.1-1 applies for intermediate connectors that are welded or fully-tensioned bolted and was derived from theory and verified by test data (Aslani and Goel, 1991). For other types of intermediate connectors on built-up members, including riveted connectors on existing bridges, Eq. C6.9.4.3.1-1 as follows should instead be applied:

$$\left(\frac{K\ell}{r}\right)_m = \sqrt{\left(\frac{K\ell}{r}\right)_o^2 + \left(\frac{a}{r_i}\right)^2} \quad (C6.9.4.3.1-1)$$

where:

r_i = minimum radius of gyration of an individual component shape (in.)

Eq. C6.9.4.3.1-1 is based empirically on test results (Zandonini, 1985). In all cases, the connectors must be designed to resist the shear forces that develop in the buckled member.

Duan, Reno, and Lynch (2000) give an approach for determining the section properties of latticed built-up members, such as the moment of inertia and torsional constant.

F_y = specified minimum yield strength (ksi)

In addition to checking the requirements of Article 6.9.4.2.1 for the clear distance between the two edge supports of the perforated cover plate utilizing a plate buckling coefficient k of 1.86, the requirements of Article 6.9.4.2.1 shall also separately be checked for the projecting width from the edge of the perforation to a single edge support utilizing a plate buckling coefficient k of 0.45.

6.9.4.4—Single-Angle Members

Single angles subject to combined axial compression and flexure about one or both principal axes and satisfying all of the following conditions, as applicable:

- End connections are to a single leg of the angle, and are welded or use a minimum of two bolts;
- The angle is loaded at the ends in compression through the same leg;
- The angle is not subjected to any intermediate transverse loads; and
- If used as web members in trusses, all adjacent web members are attached to the same side of the gusset plate or chord;

may be designed as axially loaded compression members for flexural buckling only according to the provisions of Articles 6.9.2.1, 6.9.4.1.1, and 6.9.4.1.2 provided the following effective slenderness ratio, $(K\ell/r)_{eff}$, is utilized in determining the nominal compressive resistance, P_n :

- For equal-leg angles and unequal-leg angles connected through the longer leg:

- If $\frac{\ell}{r_x} \leq 80$, then:

$$\left(\frac{K\ell}{r}\right)_{eff} = 72 + 0.75\frac{\ell}{r_x} \quad (6.9.4.4-1)$$

- If $\frac{\ell}{r_x} > 80$, then:

$$\left(\frac{K\ell}{r}\right)_{eff} = 32 + 1.25\frac{\ell}{r_x} \quad (6.9.4.4-2)$$

C6.9.4.4

Single angles are commonly used as compression members in cross-frames and lateral bracing for steel bridges. Since the angle is typically connected through one leg only, the member is subject to combined axial compression and flexure, or moments about both principal axes due to the eccentricities of the applied axial load. The angle is also usually restrained by differing amounts about its geometric x - and y -axes. As a result, the prediction of the nominal compressive resistance of these members under these conditions is difficult. The provisions contained herein provide significantly simplified provisions for the design of single-angle members satisfying certain conditions that are subject to combined axial compression and flexure. These provisions are based on the provisions for the design of single-angle members used in latticed transmission towers (ASCE, 2000). Similar provisions are also employed in Section E5 of AISC (2005).

In essence, these provisions permit the effect of the eccentricities to be neglected when these members are evaluated as axially loaded compression members for flexural buckling only using an appropriate specified effective slenderness ratio, $(K\ell/r)_{eff}$, in place of $(K\ell/r_s)$ in Eq. 6.9.4.1.2-1. The effective slenderness ratio indirectly accounts for the bending in the angles due to the eccentricity of the loading allowing the member to be proportioned according to the provisions of Article 6.9.2.1 as if it were a pinned-end concentrically loaded compression member. Furthermore, when the effective slenderness ratio is used, single angles need not be checked for flexural-torsional buckling. The actual maximum slenderness ratio of the angle, as opposed to $(K\ell/r)_{eff}$, is not to exceed the applicable limiting slenderness ratio specified in Article 6.9.3. Thus, if the actual maximum slenderness ratio of the angle exceeds the limiting ratio, a larger angle section must be selected until the ratio is satisfied. If $(K\ell/r)_{eff}$ exceeds the limiting ratio, but the actual maximum slenderness ratio of the angle does not, the design is satisfactory. The limiting ratios specified in Article 6.9.3 are well below the limiting ratio of 200 specified in AISC (2005).

- For unequal-leg angles that are connected through the shorter leg with the ratio of the leg lengths less than 1.7:

- If $\frac{\ell}{r_x} \leq 80$, then:

$$\left(\frac{K\ell}{r}\right)_{eff} = 72 + 0.75\frac{\ell}{r_x} + 4\left[\left(\frac{b_\ell}{b_s}\right)^2 - 1\right] \geq 0.95\frac{\ell}{r_z} \quad (6.9.4.4-3)$$

- If $\frac{\ell}{r_x} > 80$, then:

$$\left(\frac{K\ell}{r}\right)_{eff} = 32 + 1.25\frac{\ell}{r_x} + 4\left[\left(\frac{b_\ell}{b_s}\right)^2 - 1\right] \geq 0.95\frac{\ell}{r_z} \quad (6.9.4.4-4)$$

where:

- b_ℓ = length of the longer leg of an unequal-leg angle (in.)
- b_s = length of the shorter leg of an unequal-leg angle (in.)
- ℓ = distance between the work points of the joints measured along the length of the angle (in.)
- r_x = radius of gyration about the geometric axis of the angle parallel to the connected leg (in.)
- r_z = radius of gyration about the minor principal axis of the angle (in.)

The actual maximum slenderness ratio of the angle shall not exceed the applicable limiting slenderness ratio specified in Article 6.9.3. Single angles designed using $(K\ell/r)_{eff}$ shall not be checked for flexural-torsional buckling.

The expressions for the effective slenderness ratio presume significant end rotational restraint about the y -axis, or the axis perpendicular to the connected leg and gusset plate, as shown in Figure C6.9.4.4-1.

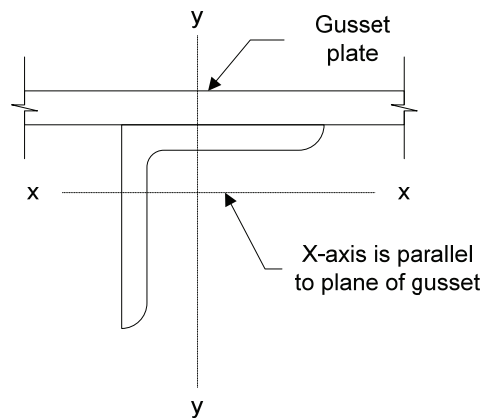

Figure C6.9.4.4-1—Single-Angle Geometric Axes Utilized in the Effective Slenderness Ratio Expressions

As a result, the angle tends to buckle primarily about the x -axis due to the eccentricity of the load about the x -axis coupled with the high degree of restraint about the y -axis (Usami and Galambos, 1971; Woolcock and Kitipornchai, 1986; Mengelkoch and Yura, 2002). Therefore, the radius of gyration in the effective slenderness ratio expressions is to be taken as r_x , or the radius of gyration about the geometric axis parallel to the connected leg, and not the minimum radius of gyration r_z about the minor principal axis of the angle. When an angle has significant rotational restraint about the y -axis, the stress along the connected leg will be approximately uniform (Lutz, 1996). Lutz (2006) compared the results from the effective slenderness ratio equations contained herein to test results for single-angle members in compression with essentially pinned-end conditions (Foehl, 1948; Trahair et al., 1969) and found an average value of P_n/P_{test} of 0.998 with a coefficient of variation of 0.109. A separate set of equations provided in AISC (2005), which assume a higher degree of x -axis rotational restraint and are thus intended for application only to single angles used as web members in box or space trusses, are not provided herein.

For the case of unequal-leg angles connected through the shorter leg, the limited available test data for this case gives lower capacities for comparable ℓ/r_x values than equal-leg angles (Lutz, 2006). Stiffening the shorter leg rotationally tends to force the buckling axis of the angle away from the x -axis and closer to the z -axis. Thus, $(K\ell/r)_{eff}$ for this case is modified by adding an additional term in Eqs. 6.9.4.4-3 and 6.9.4.4-4 along with a governing slenderness limit based on ℓ/r_z for slender unequal-leg angles. The upper limit on b_ℓ/b_s of 1.7 is based on the limits of the available physical tests. For an unequal-leg

angle connected through the longer leg, note that r_x should be taken as the smaller value about the angle geometric axes, which is typically listed as r_y in AISC (2005a).

Single-angle compression members not meeting one or more of the conditions required in this Article, or with leg length ratios b_l/b_s greater than 1.7, should instead be evaluated for combined axial load and flexure as beam-columns according to Section H2 of AISC (2005). In computing P_n for these cases, the end restraint conditions should be evaluated in calculating the effective length $K\ell$, with the in-plane effective length factor K taken equal to 1.0. When the effective length factors about both geometric axes have been computed, the procedures given in Lutz (1992) can be used to obtain a minimum effective radius of gyration for the angle. In determining whether the flexural-torsional buckling resistance of the angle needs to be considered in computing P_n , it is recommended that AISC (2000) be consulted. Also, it has been observed that the actual eccentricity in the angle is less than the distance from the centerline of the gusset if there is any restraint present about the x -axis (Lutz, 1998). In this instance, the eccentricity \bar{y} may be reduced by $t/2$, where t is the thickness of the angle, as long as the angle is on one side of the chord or gusset plate (Woolcock and Kitipornchai, 1986). The nominal flexural resistance of the angle M_n for these cases should be determined according to the procedures given in Section F10 of AISC (2005).

Single-angle members are often employed in X-type configurations in cross-frames. It has been suggested (ASCE, 2000) that for cases in such configurations, where one diagonal is in tension with a force not less than 20 percent of the force in the diagonal compression member, that the crossover or intersection point may be considered as a brace point for out-of-plane buckling. A different approach has been suggested for equally loaded compression and tension diagonals in X-type configurations in which all connections are welded (El-Tayem and Goel, 1986), which also assumes a significant level of restraint at the crossover point. While such approaches could potentially be utilized in determining the effective slenderness ratio, they have not yet received extensive validation and the assumed level of restraint may not actually be present in certain instances. For example, should the members be connected with only a single bolt at the crossover point, the necessary rotational restraint about the y -axis assumed in the effective slenderness ratio equations may not be present at that point. Thus, it is recommended herein in the interim that the effective slenderness ratio equations be conservatively applied to single-angle compression members used in X-type bracing configurations by using the full length of the diagonal between the connection work points for ℓ .

6.9.5—Composite Members

6.9.5.1—Nominal Compressive Resistance

The provisions of this Article shall apply to composite columns without flexure. The provisions of Article 6.12.2.3 shall apply to composite columns in flexure.

The nominal compressive resistance of a composite column satisfying the provisions of Article 6.9.5.2 shall be taken as:

- If $\lambda \leq 2.25$, then:

$$P_n = 0.66^\lambda F_e A_s \quad (6.9.5.1-1)$$

- If $\lambda > 2.25$, then:

$$P_n = \frac{0.88 F_e A_s}{\lambda} \quad (6.9.5.1-2)$$

in which:

$$\lambda = \left(\frac{K \ell}{r_s \pi} \right)^2 \frac{F_e}{E_e} \quad (6.9.5.1-3)$$

$$F_e = F_y + C_1 F_{yr} \left(\frac{A_r}{A_s} \right) + C_2 f'_c \left(\frac{A_c}{A_s} \right) \quad (6.9.5.1-4)$$

$$E_e = E \left[1 + \left(\frac{C_3}{n} \right) \left(\frac{A_c}{A_s} \right) \right] \quad (6.9.5.1-5)$$

where:

- A_s = cross-sectional area of the steel section (in.²)
- A_c = cross-sectional area of the concrete (in.²)
- A_r = total cross-sectional area of the longitudinal reinforcement (in.²)
- F_y = specified minimum yield strength of the steel section (ksi)
- F_{yr} = specified minimum yield strength of the longitudinal reinforcement (ksi)
- f'_c = specified minimum 28-day compressive strength of the concrete (ksi)
- E = modulus of elasticity of the steel (ksi)
- ℓ = unbraced length of the column (in.)
- K = effective length factor as specified in Article 4.6.2.5
- n = modular ratio of the concrete as specified in Article 6.10.1.1.1b
- r_s = radius of gyration of the steel section in the plane of bending but not less than 0.3 times the width of the composite member in the plane of bending for composite concrete-encased shapes (in.)
- $C_1, C_2,$
- C_3 = composite column constant specified in Table 6.9.5.1-1

C6.9.5.1

The procedure for the design of composite columns is the same as that for the design of steel columns, except that the specified minimum yield strength of structural steel, the modulus of elasticity of steel, and the radius of gyration of the steel section are modified to account for the effect of concrete and of longitudinal reinforcing bars. Explanation of the origin of these modifications and comparison of the design procedure, with the results of numerous tests, may be found in SSRC Task Group 20 (1979) and Galambos and Chapis (1980).

Table 6.9.5.1-1—Composite Column Constants

	Filled Tubes	Encased Shapes
C_1	1.00	0.70
C_2	0.85	0.60
C_3	0.40	0.20

In determining the moment magnification for composite members subject to combined axial compression and flexure according to the approximate single step adjustment specified in Article 4.5.3.2.2b, the following shall apply:

$$P_e = \frac{A_s F_e}{\lambda} \quad (6.9.5.1-6)$$

6.9.5.2—Limitations

6.9.5.2.1—General

The compressive resistance shall be calculated in accordance with Article 6.9.5.1 if the cross-sectional area of the steel section comprises at least four percent of the total cross-sectional area of the member.

The compressive resistance shall be calculated as a reinforced concrete column under Section 5 if the cross-sectional area of the shape or tube is less than four percent of the total cross-sectional area.

The compressive strength of the concrete shall be between 3.0 ksi and 8.0 ksi.

The specified minimum yield strength of the steel section and the longitudinal reinforcement used to calculate the nominal compressive resistance shall not exceed 60.0 ksi.

The transfer of all load in the composite column shall be considered in the design of supporting components.

The cross-section shall have at least one axis of symmetry.

6.9.5.2.2—Concrete-Filled Tubes

The wall thickness requirements for unfilled tubes specified in Article 6.9.4.2 shall apply to filled composite tubes.

6.9.5.2.3—Concrete-Encased Shapes

Concrete-encased steel shapes shall be reinforced with longitudinal and lateral reinforcement. The reinforcement shall conform to the provisions of Article 5.7.4.6, except that the vertical spacing of lateral ties shall not exceed the least of:

C6.9.5.2.1

Little of the test data supporting the development of the present provisions for design of composite columns involved concrete strengths in excess of 6.0 ksi. Normal weight concrete was believed to have been used in all tests. A lower limit of 3.0 ksi is specified to encourage the use of good-quality concrete.

C6.9.5.2.3

Concrete-encased shapes are not subject to the width/thickness limitations specified in Article 6.9.4.2 because it has been shown that the concrete provides adequate support against local buckling.

- 16 longitudinal bar diameters,
- 48 tie bar diameters, or
- 0.5 of the least side dimension of the composite member.

Multiple steel shapes in the same cross-section of a composite column shall be connected to one another with lacing and tie plates to prevent buckling of individual shapes before hardening of the concrete.

6.10—I-SECTION FLEXURAL MEMBERS

6.10.1—General

The provisions of this Article apply to flexure of rolled or fabricated straight, kinked (chorded) continuous, or horizontally curved steel I-section members symmetrical about the vertical axis in the plane of the web. These provisions cover the design of composite and noncomposite sections, hybrid and nonhybrid sections, and constant and variable web depth members as defined by and subject to the requirements of Articles 6.10.1.1 through 6.10.1.8. The provisions also cover the combined effects of major-axis bending and flange lateral bending from any source.

All types of I-section flexural members shall be designed as a minimum to satisfy:

- The cross-section proportion limits specified in Article 6.10.2;
- The constructibility requirements specified in Article 6.10.3;
- The service limit state requirements specified in Article 6.10.4;
- The fatigue and fracture limit state requirements specified in Article 6.10.5;
- The strength limit state requirements specified in Article 6.10.6.

The web bend-buckling resistance in slender web members shall be determined as specified in Article 6.10.1.9. Flange-strength reduction factors in hybrid and/or slender web members shall be determined as specified in Article 6.10.1.10.

Cross-frames and diaphragms for I-sections shall satisfy the provisions of Article 6.7.4. Where required, lateral bracing for I-sections shall satisfy the provisions of Article 6.7.5.

C6.10.1

This Article addresses general topics that apply to all types of steel I-sections in either straight bridges, horizontally curved bridges, or bridges containing both straight and curved segments. For the application of the provisions of Article 6.10, bridges containing both straight and curved segments are to be treated as horizontally curved bridges since the effects of curvature on the support reactions and girder deflections, as well as the effects of flange lateral bending, usually extend beyond the curved segments. Note that kinked (chorded) girders exhibit the same actions as curved girders, except that the effect of the noncollinearity of the flanges is concentrated at the kinks. Continuous kinked (chorded) girders should be treated as horizontally curved girders with respect to these Specifications.

The five bullet items in this Article indicate the overarching organization of the subsequent provisions for the design of straight I-section flexural members. Each of the subarticles throughout Article 6.10 are written such that they are largely self-contained, thus minimizing the need for reference to multiple Articles to address any one of the essential design considerations. For the strength limit state, Article 6.10.6 directs the Engineer to the subsequent Articles 6.10.7 through 6.10.12, and optionally for sections in straight I-girder bridges only, to Appendices A6 and B6, for the appropriate design requirements based on the type of I-section. The specific provisions of these Articles and Appendices are discussed in the corresponding Articles of the Commentary.

The provisions of Article 6.10 and the optional Appendices A6 and B6 provide a unified approach for consideration of combined major-axis bending and flange lateral bending from any source. For the majority of straight non-skewed bridges, flange lateral bending effects tend to be most significant during construction and tend to be insignificant in the final constructed condition. Significant flange lateral bending may be caused by wind, by torsion from eccentric concrete deck overhang loads acting on cantilever forming brackets placed along exterior girders, and by the use of discontinuous cross-frames, i.e., not forming a continuous line between multiple girders, in conjunction with skews exceeding 20 degrees. In these

cases, the flange lateral bending may be considered at the discretion of the Engineer. Although the use of refined analysis methods is not required in order to fulfill the requirements of these provisions, these methods, when utilized, do allow for consideration of these effects. Some of these effects have not been addressed explicitly in previous Specifications. The intent of the Article 6.10 provisions is to permit the Engineer to consider flange lateral bending effects in the design in a direct and rational manner should they be judged to be significant. In the absence of calculated values of f_{ℓ} from a refined analysis, a suggested estimate for the total unfactored f_{ℓ} in a flange at a cross-frame or diaphragm due to the use of discontinuous cross-frame or diaphragm lines is 10.0 ksi for interior girders and 7.5 ksi for exterior girders. These estimates are based on a limited examination of refined analysis results for bridges with skews approaching 60 degrees from normal and an average D/b_j ratio of approximately 4.0. In regions of the girders with contiguous cross-frames or diaphragms, these values need not be considered. Lateral flange bending in the exterior girders is substantially reduced when cross-frames or diaphragms are placed in discontinuous lines over the entire bridge due to the reduced cross-frame or diaphragm forces. A value of 2.0 ksi is suggested for f_{ℓ} for the exterior girders in such cases, with the suggested value of 10 ksi retained for the interior girders. In all cases, it is suggested that the recommended values of f_{ℓ} be proportioned to dead and live load in the same proportion as the unfactored major-axis dead and live load stresses at the section under consideration. An examination of cross-frame or diaphragm forces is also considered prudent in all bridges with skew angles exceeding 20 degrees. When all the above lateral bending effects are judged to be insignificant or incidental, the flange lateral bending term, f_{ℓ} , is simply set equal to zero in the appropriate equations. The format of the equations then reduces simply to the more conventional and familiar format for checking the nominal flexural resistance of I-sections in the absence of flange lateral bending.

For horizontally curved bridges, in addition to the potential sources of flange lateral bending discussed in the preceding paragraph, flange lateral bending effects due to curvature must always be considered at all limit states and also during construction.

The fact that new design equations and provisions are provided herein does not imply that existing bridges are unsafe or structurally deficient. It also does not mandate the need to rehabilitate or perform a new load rating of existing structures to satisfy these provisions.

Flowcharts for flexural design of I-section members are provided in Appendix C6. Fundamental calculations for flexural members previously found in Article 6.10.3 of AASHTO (2004) have been placed in Appendix D6.

6.10.1.1—Composite Sections

Sections consisting of a concrete deck that provides proven composite action and lateral support connected to a steel section by shear connectors designed according to the provisions of Article 6.10.10 shall be considered composite sections.

6.10.1.1.1—Stresses

6.10.1.1.1a—Sequence of Loading

The elastic stress at any location on the composite section due to the applied loads shall be the sum of the stresses caused by the loads applied separately to the:

- Steel section,
- Short-term composite section, and
- Long-term composite section.

For unshored construction, permanent load applied before the concrete deck has hardened or is made composite shall be assumed carried by the steel section alone; permanent load and live load applied after this stage shall be assumed carried by the composite section. For shored construction, all permanent load shall be assumed applied after the concrete deck has hardened or has been made composite and the contract documents shall so indicate.

6.10.1.1.1b—Stresses for Sections in Positive Flexure

For calculating flexural stresses within sections subjected to positive flexure, the composite section shall consist of the steel section and the transformed area of the effective width of the concrete deck. Concrete on the tension side of the neutral axis shall not be considered effective at the strength limit state.

For transient loads assumed applied to the short-term composite section, the concrete deck area shall be transformed by using the short-term modular ratio, n . For permanent loads assumed applied to the long-term composite section, the concrete deck area shall be transformed by using the long-term modular ratio, $3n$. Where moments due to the transient and permanent loads are of opposite sign at the strength limit state, the associated composite section may be used with each of these moments if the resulting net stress in the concrete deck due to the sum of the unfactored moments is compressive. Otherwise, the provisions of Article 6.10.1.1.1c shall be used to determine the stresses in the steel section. Stresses in the concrete deck shall be determined as specified in Article 6.10.1.1.1d.

C6.10.1.1.1a

Previous Specifications indicated that a concrete slab may be considered sufficiently hardened after the concrete attains 75 percent of its specified 28-day compressive strength f'_c . Other indicators may be used based on the judgment of the Engineer.

While shored construction is permitted according to these provisions, its use is not recommended. Unshored construction generally is expected to be more economical. Also, these provisions may not be sufficient for shored construction where close tolerances on the girder cambers are important. There has been limited research on the effects of concrete creep on composite steel girders under large dead loads. There have been no known significant demonstration bridges built with shored construction in the U.S. Shored composite bridges that are known to have been constructed in Germany did not retain composite action. Furthermore, there is an increased likelihood of significant tensile stresses occurring in the concrete deck at permanent support points when shored construction is used.

C6.10.1.1.1b

For normal-weight concrete, the modular ratio may be taken as:

$2.4 \leq f'_c < 2.9$	$n = 10$
$2.9 \leq f'_c < 3.6$	$n = 9$
$3.6 \leq f'_c < 4.6$	$n = 8$
$4.6 \leq f'_c < 6.0$	$n = 7$
$6.0 \leq f'_c$	$n = 6$

The modular ratio should be taken as:

$$n = \frac{E}{E_c} \quad (6.10.1.1.1b-1)$$

where:

E_c = modulus of elasticity of the concrete determined as specified in Article 5.4.2.4 (ksi)

6.10.1.1.1c—Stresses for Sections in Negative Flexure

For calculating flexural stresses in sections subjected to negative flexure, the composite section for both short-term and long-term moments shall consist of the steel section and the longitudinal reinforcement within the effective width of the concrete deck, except as specified otherwise in Article 6.6.1.2.1, Article 6.10.1.1.1d or Article 6.10.4.2.1.

6.10.1.1.1d—Concrete Deck Stresses

For calculating longitudinal flexural stresses in the concrete deck due to all permanent and transient loads, the short-term modular ratio, n , shall be used.

C6.10.1.1.1d

Previous Specifications required that the longitudinal flexural stresses in the concrete deck due to permanent load be calculated using the n or the $3n$ section, whichever gives the more critical stress within the deck. When the deck stresses due to short-term and permanent loads are of the same sign, the n section generally governs the deck stress calculation. Also, the maximum combined compression in the deck typically occurs at a section where the permanent and short-term stresses are additive. However, when considering the length of the deck over which the provisions of Article 6.10.1.7 are to be applied, smaller compressive permanent load stresses can result in larger net tensile stresses in the deck in the vicinity of inflection point locations. In these situations, use of the $3n$ section for the permanent load stresses produces the more critical tension stress in the deck. This level of refinement in the calculation of the deck longitudinal tension stresses is considered unjustified.

6.10.1.1.1e—Effective Width of Concrete Deck

The effective width of the concrete deck shall be determined as specified in Article 4.6.2.6.

6.10.1.2—Noncomposite Sections

Sections where the concrete deck is not connected to the steel section by shear connectors designed in accordance with the provisions of Article 6.10.10 shall be considered noncomposite sections.

C6.10.1.2

Noncomposite sections are not recommended, but are permitted.

6.10.1.3—Hybrid Sections

The specified minimum yield strength of the web should not be less than the larger of 70 percent of the specified minimum yield strength of the higher strength flange and 36.0 ksi.

For members with a higher-strength steel in the web than in one or both flanges, the yield strength of the web shall not be taken greater than 120 percent of the specified minimum yield strength of the lower strength flange in determining the flexural and shear resistance. Composite girders in positive flexure with a higher strength steel in the web than in the compression flange may use the full web strength in determining their flexural and shear resistance.

6.10.1.4—Variable Web Depth Members

The effect of bottom flange inclination shall be considered in determining the bottom flange stress caused by bending about the major-axis of the cross-section. Where permitted by static equilibrium, the web dead-load shear may be reduced by the vertical component of the bottom flange force.

At points where the bottom flange becomes horizontal, the transfer of the vertical component of the flange force back into the web shall be considered.

C6.10.1.3

Hybrid sections consisting of a web with a specified minimum yield strength lower than that of one or both of the flanges may be designed with these Specifications. Although these provisions can be safely applied to all types of hybrid sections (ASCE, 1968), it is recommended that the difference in the specified minimum yield strengths of the web and the higher strength flange preferably be limited to one steel grade. Such sections generally are believed to have greater design efficiency. For these types of sections, the upper limit of F_{yw} on the value of F_{yf} , determined in Article 6.10.8.2.2, 6.10.8.2.3, A6.3.2 or A6.3.3 as applicable, does not govern. Furthermore, as discussed in Article C6.10.1.9.1, this minimum limit on the web yield strength guards against early inelastic web bend-buckling of slender hybrid webs.

A number of the curved noncomposite I-girders tested by Mozer and Culver (1970) and Mozer et al. (1971) had F_{yw}/F_{yf} between 0.72 and 0.76. The flexural and shear strengths of these hybrid I-girders are predicted adequately by these Specifications, including the development of shear strengths associated with tension field action. The major-axis bending stresses tend to be smaller in curved I-girder webs compared to straight I-girder webs, since part of the flexural resistance is taken up by flange lateral bending. The provisions of Articles 6.10.2 and 6.10.5.3 prevent significant out-of-plane flexing of the web in straight and curved hybrid I-girders (Yen and Mueller, 1966; ASCE, 1968).

Test data for sections with nominally larger yield strengths in the web than in one or both flanges are limited. Nevertheless, in many experimental tests, the actual yield strength of the thinner web is larger than that of the flanges. The nominal yield strength that may be used for the web in determining the flexural and shear resistance for such cases is limited within these Specifications to a range supported by the available test data.

C6.10.1.4

If the normal stress in an inclined bottom flange, calculated without consideration of flange lateral bending, is determined by simply dividing the bending moment about the major-axis of the cross-section by the elastic section modulus, this stress is generally underestimated. The normal stress within an inclined bottom flange may be determined by first calculating the horizontal component of the flange force required to develop this bending moment as:

$$P_h = MA_f / S_x \quad (\text{C6.10.1.4-1})$$

where:

$$A_f = \text{area of the inclined bottom flange (in.}^2\text{)}$$

- M = bending moment about the major-axis of the cross-section at the section under consideration (kip-in.)
- S_x = elastic section modulus to the inclined bottom flange (in.³)

For composite sections, the provisions of Article 6.10.1.1.1a are to be applied in computing P_h . The normal stress in the inclined flange, f_n , may then be determined as (Blodgett, 1982):

$$f_n = P_h / A_f \cos \theta \quad (\text{C6.10.1.4-2})$$

where:

- θ = angle of inclination of the bottom flange (degrees)

The corresponding vertical component of the flange force, P_v , may be determined as:

$$P_v = P_h \tan \theta \quad (\text{C6.10.1.4-3})$$

This component of the flange force affects the vertical web shear. In regions of positive flexure with tapered or parabolic haunches sloping downward toward the supports, the vertical web shear is increased by P_v . For fish belly haunches, $P_v = 0$ near the supports. For all other cases, the vertical web shear is reduced by P_v . The Specifications permit the Engineer to reduce the web dead-load shear accordingly in these cases. Calculation of the reduced live-load shear is problematic because numerous sets of concurrent moments and shears must be evaluated in order to determine the critical or smallest shear reduction, and thus is not likely worth the effort. Also, variable depth webs are used most often on longer-span girders where dead load is more predominant.

In parabolic haunches, where the downward slope of the bottom flange is larger at positions closer to the interior support, the change in the bottom-flange inclination in combination with compressive stress in the bottom flange induces a compressive distributed transverse force on the web (Blodgett, 1982). If the girder web is unstiffened or transversely-stiffened with a stiffener spacing d_o greater than approximately $1.5D$ within this type of haunch, the Engineer should check the stability of the web under this force.

At points where an inclined flange becomes horizontal, the vertical component of the inclined flange force is transferred back into the web as a concentrated load. This concentrated load causes additional stress in the web and web-to-bottom flange welds, and will often require additional local stiffening. At these locations, the web is sufficient without additional stiffening if the requirement of Article D6.5.2 is satisfied using a length of bearing N equal to zero. At locations where the concentrated load is compressive and N is equal to zero,

6.10.1.5—Stiffness

The following stiffness properties shall be used in the analysis of flexural members:

- For loads applied to noncomposite sections: the stiffness properties of the steel section alone.
- For permanent loads applied to composite sections: the stiffness properties of the long-term composite section, assuming the concrete deck to be effective over the entire span length.
- For transient loads applied to composite sections: the stiffness properties of the short-term composite section, assuming the concrete deck to be effective over the entire span length.

6.10.1.6—Flange Stresses and Member Bending Moments

For design checks where the flexural resistance is based on lateral torsional buckling:

- The stress f_{bu} shall be determined as the largest value of the compressive stress throughout the unbraced length in the flange under consideration, calculated without consideration of flange lateral bending.
- The moment M_u shall be determined as the largest value of the major-axis bending moment throughout the unbraced length causing compression in the flange under consideration.
- The stress f_t shall be determined as the largest value of the stress due to lateral bending throughout the unbraced length in the flange under consideration.

For design checks where the flexural resistance is based on yielding, flange local buckling or web bend-buckling, f_{bu} , M_u and f_t may be determined as the corresponding values at the section under consideration.

The values of f_{bu} , M_u and f_t shall be determined based on factored loads, and shall be taken as positive in sign in all resistance equations.

Lateral bending stresses in continuously braced flanges shall be taken equal to zero. Lateral bending stresses in discretely braced flanges shall be determined by structural analysis. All discretely braced flanges shall satisfy:

the provisions of Article D6.5.2 generally govern relative to those of Article D6.5.3; therefore, satisfaction of the requirement of Article D6.5.2 using a length of bearing N equal to zero ensures that the web is adequate without additional stiffening for locations subjected to compressive or tensile concentrated transverse loads.

C6.10.1.5

In line with common practice, it is specified that the stiffness of the steel section alone be used for noncomposite sections, although numerous field tests have shown that considerable unintended composite action occurs in such sections.

Field tests of composite continuous bridges have shown that there is considerable composite action in negative bending regions (Baldwin et al., 1978; Roeder and Eltvik, 1985; Yen et al., 1995). Therefore, the stiffness of the full composite section is to be used over the entire bridge length for the analysis of composite flexural members.

C6.10.1.6

For checking of lateral torsional buckling resistance, the correct value of the stress f_{bu} or moment M_u is generally the largest value causing compression in the flange under consideration throughout the unbraced length.

For a discretely braced compression flange also subject to lateral bending, the largest lateral bending stress throughout the unbraced length of the flange under consideration must be used in combination with f_{bu} or M_u when the resistance is based on lateral torsional buckling. Combined vertical and flange lateral bending is addressed in these Specifications by effectively handling the flanges as equivalent beam-columns. The use of the maximum f_t and f_{bu} or M_u values within the unbraced length, when the resistance is governed by member stability, i.e., lateral torsional buckling, is consistent with established practice in the proper application of beam-column interaction equations.

Yielding, flange local buckling and web bend-buckling are considered as cross-section limit states. Hence, the Engineer is allowed to use coincident cross-section values of f_t and f_{bu} or M_u when checking these limit states. Generally, this approach necessitates checking of the limit states at various cross-sections along the unbraced length. When the maximum values of f_t and f_{bu} or M_u occur at different locations within the unbraced length, it is conservative to use the maximum values in a single application of the yielding and flange local buckling equations. Flange lateral bending does not enter into the web bend-buckling resistance equations.

$$f_{\ell} \leq 0.6F_{yf} \quad (6.10.1.6-1)$$

The flange lateral bending stress, f_{ℓ} , may be determined directly from first-order elastic analysis in discretely braced compression flanges for which:

$$L_b \leq 1.2L_p \sqrt{\frac{C_b R_b}{f_{bu} / F_{yc}}} \quad (6.10.1.6-2)$$

or equivalently:

$$L_b \leq 1.2L_p \sqrt{\frac{C_b R_b}{M_u / M_{yc}}} \quad (6.10.1.6-3)$$

where:

C_b = moment gradient modifier specified in Article 6.10.8.2.3 or Article A6.3.3, as applicable.

f_{bu} = largest value of the compressive stress throughout the unbraced length in the flange under consideration, calculated without consideration of flange lateral bending (ksi)

L_b = unbraced length (in.)

L_p = limiting unbraced length specified in Article 6.10.8.2.3 (in.)

M_u = largest value of the major-axis bending moment throughout the unbraced length causing compression in the flange under consideration (kip-in.)

M_{yc} = yield moment with respect to the compression flange determined as specified in Article D6.2 (kip-in.)

R_b = web load-shedding factor determined as specified in Article 6.10.1.10.2

If Eq. 6.10.1.6-2, or Eq. 6.10.1.6-3 as applicable, is not satisfied, second-order elastic compression-flange lateral bending stresses shall be determined.

Second-order compression-flange lateral bending stresses may be approximated by amplifying first-order values as follows:

$$f_{\ell} = \left(\frac{0.85}{1 - \frac{f_{bu}}{F_{cr}}} \right) f_{\ell 1} \geq f_{\ell 1} \quad (6.10.1.6-4)$$

or equivalently:

In lieu of a more refined analysis, Article C6.10.3.4 gives approximate equations for calculation of the maximum flange lateral bending moments due to eccentric concrete deck overhang loads acting on cantilever forming brackets placed along exterior members. Determination of flange wind moments is addressed in Article 4.6.2.7. The determination of flange lateral bending moments due to the effect of discontinuous cross-frames and/or support skew is best handled by a direct structural analysis of the bridge superstructure. The determination of flange lateral bending moments due to curvature is addressed in Article 4.6.1.2.4b.

In all resistance equations, f_{bu} , M_u , and f_{ℓ} are to be taken as positive in sign. However, for service and strength limit state checks at locations where the dead and live load contributions to f_{bu} , M_u or f_{ℓ} are of opposite sign, the signs of each contribution must be initially taken into account. In such cases, for both dead and live load, the appropriate net sum of the major-axis and lateral bending actions due to the factored loads must be computed, taking the signs into consideration that will result in the most critical response for the limit state under consideration.

The top flange may be considered continuously braced where it is encased in concrete or anchored to the deck by shear connectors satisfying the provisions of Article 6.10.10. For a continuously braced flange in tension or compression, flange lateral bending effects need not be considered. Additional lateral bending stresses are small once the concrete deck has been placed. Lateral bending stresses induced in a continuously braced flange prior to this stage need not be considered after the deck has been placed. The resistance of the composite concrete deck is generally adequate to compensate for the neglect of these initial lateral bending stresses. The Engineer should consider the non-composite lateral bending stresses in the top flange if the flange is not continuously supported by the deck.

The provisions of Article 6.10 for handling of combined vertical and flange lateral bending are limited to I-sections that are loaded predominantly in major-axis bending. For cases in which the elastically computed flange lateral bending stress is larger than approximately $0.6F_{yf}$, the reduction in the major-axis bending resistance due to flange lateral bending tends to be greater than that determined based on these provisions. The service and strength limit state provisions of these Specifications are sufficient to ensure acceptable performance of I-girders with elastically computed f_{ℓ} values somewhat larger than this limit.

Eq. 6.10.1.6-2, or equivalently Eq. 6.10.1.6-3 as applicable, simply gives a maximum value of L_b for which $f_{\ell} = f_{\ell 1}$ in Eq. 6.10.1.6-4 or 6.10.1.6-5. Eq. 6.10.1.6-4, or equivalently Eq. 6.10.1.6-5 as applicable, is an approximate formula that accounts for the amplification of the first-order compression-flange lateral bending stresses due to second-order effects. This equation, which is an established form for estimating the maximum second-order elastic moments in braced beam-column members whose ends are restrained by other framing, tends to be significantly conservative for

$$f_{\ell} = \left(\frac{0.85}{1 - \frac{M_u}{F_{cr} S_{xc}}} \right) f_{\ell 1} \geq f_{\ell 1} \quad (6.10.1.6-5)$$

where:

- f_{bu} = largest value of the compressive stress throughout the unbraced length in the flange under consideration, calculated without consideration of flange lateral bending (ksi)
- $f_{\ell 1}$ = first-order compression-flange lateral bending stress at the section under consideration, or the maximum first-order lateral bending stress in the compression flange under consideration throughout the unbraced length, as applicable (ksi)
- F_{cr} = elastic lateral torsional buckling stress for the flange under consideration determined from Eq. 6.10.8.2.3-8 or Eq. A6.3.3-8. Eq. A6.3.3-8 may only be applied for unbraced lengths in straight I-girder bridges in which the web is compact or noncompact.
- M_u = largest value of the major-axis bending moment throughout the unbraced length causing compression in the flange under consideration (kip-in.)
- S_{xc} = elastic section modulus about the major axis of the section to the compression flange taken as M_{yc}/F_{yc} (in.³)

6.10.1.7—Minimum Negative Flexure Concrete Deck Reinforcement

Wherever the longitudinal tensile stress in the concrete deck due to either the factored construction loads or Load Combination Service II in Table 3.4.1-1 exceeds ϕf_r , the total cross-sectional area of the longitudinal reinforcement shall not be less than one percent of the total cross-sectional area of the concrete deck. ϕ shall be taken as 0.9 and f_r shall be taken as the modulus of rupture of the concrete determined as follows:

- For normal-weight concrete: $f_r = 0.24\sqrt{f'_c}$
- For lightweight concrete: f_r is calculated as specified in Article 5.4.2.6,

The longitudinal stresses in the concrete deck shall be determined as specified in Article 6.10.1.1.d. The reinforcement used to satisfy this requirement shall have a specified minimum yield strength not less than 60.0 ksi; the size of the reinforcement should not exceed No. 6 bars.

The required reinforcement should be placed in two layers uniformly distributed across the deck width, and

larger unsupported lengths associated with f_{bu} approaching F_{cr} (White et al., 2001). This conservatism exists even when an effective length factor for lateral torsional buckling and/or a moment gradient factor C_b is considered in the calculation of F_{cr} , and even when one end of the unbraced segment under consideration is not restrained by an adjacent segment. Although Eqs. 6.10.1.6-4 and 6.10.1.6-5 are directed at estimating the maximum second-order lateral bending stress within the unbraced length, by use of the maximum first-order lateral bending stress for $f_{\ell 1}$, they may be applied for estimating the second-order lateral bending stresses at any cross-section within the unbraced length under consideration by use of the corresponding value of $f_{\ell 1}$ at that location.

The purpose of Eqs. 6.10.1.6-4 and 6.10.1.6-5 is to guard conservatively against large unbraced lengths in which the flange second-order lateral bending effects are significant. In construction situations where the amplification within these equations is large, the Engineer may wish to consider a direct geometric nonlinear analysis to more accurately determine the second-order effects within the superstructure, or using a lower value of the effective length factor for lateral torsional buckling to appropriately increase F_{cr} according to the procedure suggested in Article C6.10.8.2.3.

Note that the calculated value of F_{cr} for use in Eq. 6.10.1.6-4 is not limited to $R_b R_h F_{yc}$ as specified in Article 6.10.8.2.3, and that the calculated value of $F_{cr} S_{xc}$ for use in Eq. 6.10.1.6-5 is not limited to $R_{pc} M_{yc}$ as specified in Article A6.3.3. The elastic buckling stress is the appropriate stress for use in Eqs. 6.10.1.6-4 and 6.10.1.6-5 to estimate the elastic second-order amplification of the flange lateral bending stresses.

The definitions of a compact web and of a noncompact web are discussed in Article C6.10.6.2.3.

C6.10.1.7

The use of one percent reinforcement with a size not exceeding No. 6 bars, a yield strength greater than or equal to 60.0 ksi, and spacing at intervals not exceeding 12.0 in. is intended to control concrete deck cracking. Pertinent criteria for concrete crack control are discussed in more detail in AASHTO (1991) and in Haaijer et al. (1987).

Previously, the requirement for one percent longitudinal reinforcement was limited to negative flexure regions of continuous spans, which are often implicitly taken as the regions between points of dead load contraflexure. Under moving live loads, the deck can experience significant tensile stresses outside the points of dead load contraflexure. Placement of the concrete deck in stages can also produce negative flexure during construction in regions where the deck already has been placed, although these regions may be subjected primarily to positive flexure in the final condition. Thermal and shrinkage strains can also cause tensile stresses in the deck in regions where such stresses otherwise might not be anticipated. To address these issues, the one percent

two-thirds should be placed in the top layer. The individual bars should be spaced at intervals not exceeding 12.0 in.

Where shear connectors are omitted from the negative flexure region, all longitudinal reinforcement shall be extended into the positive flexure region beyond the additional shear connectors specified in Article 6.10.10.3 a distance not less than the development length specified in Section 5.

longitudinal reinforcement is to be placed wherever the tensile stress in the deck due to either the factored construction loads, including loads during the various phases of the deck placement sequence, or due to Load Combination Service II in Table 3.4.1-1, exceeds ϕf_c . By satisfying the provisions of this Article to control the crack size in regions where adequate shear connection is also provided, the concrete deck may be considered to be effective in tension for computing fatigue stress ranges, as permitted in Article 6.6.1.2.1, and in determining flexural stresses on the composite section due to Load Combination Service II, as permitted in Article 6.10.4.2.1.

In addition to providing one percent longitudinal deck reinforcement, nominal yielding of this reinforcement should be prevented at Load Combination Service II (Carskaddan, 1980; AASHTO, 1991; Grubb, 1993) to control concrete deck cracking. The use of longitudinal deck reinforcement with a specified minimum yield strength not less than 60.0 ksi may be taken to preclude nominal yielding of the longitudinal reinforcement under this load combination in the following cases:

- Unshored construction where the steel section utilizes steel with a specified minimum yield strength less than or equal to 70.0 ksi in either flange, or
- Shored construction where the steel section utilizes steel with a specified minimum yield strength less than or equal to 50.0 ksi in either flange.

In these cases, the effects of any nominal yielding within the longitudinal reinforcing steel are judged to be insignificant. Otherwise, the Engineer should check to ensure that nominal yielding of the longitudinal reinforcement does not occur under the applicable Service II loads. The above rules are based on Carskaddan (1980) and apply for members that are designed by the provisions of Article 6.10 or Appendix A6, as well as for members that are designed for redistribution of the pier section moments at the Service II Load Combination using the provisions of Appendix B6.

Where feasible, approximately two-thirds of the required reinforcement should be placed in the top layer. When precast deck panels are used as deck forms, it may not be possible to place the longitudinal reinforcement in two layers. In such cases, the placement requirements may be waived at the discretion of the Engineer.

6.10.1.8—Net Section Fracture

When checking flexural members at the strength limit state or for constructibility, the following additional requirement shall be satisfied at all cross-sections containing holes in the tension flange:

$$f_t \leq 0.84 \left(\frac{A_n}{A_g} \right) F_u \leq F_{yt} \quad (6.10.1.8-1)$$

where:

- A_n = net area of the tension flange determined as specified in Article 6.8.3 (in.²)
- A_g = gross area of the tension flange (in.²)
- f_t = stress on the gross area of the tension flange due to the factored loads calculated without consideration of flange lateral bending (ksi)
- F_u = specified minimum tensile strength of the tension flange determined as specified in Table 6.4.1-1 (ksi)

6.10.1.9—Web Bend-Buckling Resistance

6.10.1.9.1—Webs without Longitudinal Stiffeners

The nominal bend-buckling resistance shall be taken as:

$$F_{crw} = \frac{0.9Ek}{\left(\frac{D}{t_w} \right)^2} \quad (6.10.1.9.1-1)$$

but not to exceed the smaller of $R_h F_{yc}$ and $F_{yw}/0.7$

in which:

- k = bend-buckling coefficient
- $k = \frac{9}{(D_c/D)^2} \quad (6.10.1.9.1-2)$

where:

- D_c = depth of the web in compression in the elastic range (in.). For composite sections, D_c shall be determined as specified in Article D6.3.1.
- R_h = hybrid factor specified in Article 6.10.1.10.1

C6.10.1.8

If Eq. 6.10.1.8-1 is satisfied under the stated conditions at a cross-section containing holes in the tension flange, fracture on the net section of the flange is prevented. For holes larger than those typically used for connectors such as bolts, refer to Article 6.8.1.

At compact composite sections in positive flexure and at sections designed according to the optional provisions of Appendix A6 with no holes in the tension flange, the nominal flexural resistance is permitted to exceed the moment at first yield at the strength limit state. Pending the results from further research, it is conservatively required that Eq. 6.10.1.8-1 also be satisfied at the strength limit state at any such cross-sections containing holes in the tension flange. It has not yet been fully documented that complete plastification of the cross-section can occur at these sections prior to fracture on the net section of the tension flange. Furthermore, the splice design provisions of Article 6.13.6.1.4 do not consider the contribution of substantial web yielding to the flexural resistance of these sections. Eq. 6.10.1.8-1 will likely prevent holes from being located in the tension flange at or near points of maximum applied moment where significant yielding of the web, beyond the localized yielding permitted in hybrid sections, may occur.

The factor 0.84 in Eq. 6.10.1.8-1 is approximately equivalent to the ratio of the resistance factor for fracture of tension members, ϕ_b , to the resistance factor for yielding of tension members, ϕ_y , specified in Article 6.5.4.2.

C6.10.1.9.1

In subsequent Articles, the web theoretical bend-buckling resistance is checked generally against the maximum compression-flange stress due to the factored loads, calculated without consideration of flange lateral bending. The precision associated with making a distinction between the stress in the compression flange and the maximum compressive stress in the web is not warranted. The potential use of a value of F_{crw} greater than the specified minimum yield strength of the web, F_{yw} , in hybrid sections is justified since the flange tends to restrain the longitudinal strains associated with web bend-buckling for nominal compression-flange stresses up to $R_h F_{yc}$. A stable nominally elastic compression flange constrains the longitudinal and plate bending strains in the inelastic web at the web-flange juncture (ASCE, 1968). ASCE (1968) recommends that web bend-buckling does not need to be considered in hybrid sections with F_{yc} up to 100 ksi as long as the web slenderness does not exceed $5.87\sqrt{E/F_{yc}}$. Eq. 6.10.1.9.1-1 predicts $F_{crw} = F_{yc}$ at $2D_c/t_w = 5.7\sqrt{E/F_{yc}}$. For hybrid sections with $F_{yw}/F_{yc} < 0.7$, these provisions adopt a more conservative approach than recommended by ASCE (1968) by limiting F_{crw} to the smaller of $R_h F_{yc}$ and $F_{yw}/0.7$. The

When both edges of the web are in compression, k shall be taken as 7.2.

flexural resistance equations of these Specifications give somewhat conservative predictions for the strengths of hybrid members without longitudinal stiffeners tested by Lew and Toprac (1968) that had D/t_w and $2D_o/t_w$ values as high as 305 and $F_{yw}/F_{yc} = 0.32$. Therefore, no additional requirements are necessary at the strength limit state for all potential values of F_{yw}/F_{yc} associated with the steels specified in Article 6.4.1.

In many experimental tests, noticeable web plate bending deformations and associated transverse displacements occur from the onset of load application due to initial web out-of-flatness. Because of the stable postbuckling behavior of the web, there is no significant change in the rate of increase of the web transverse displacements as a function of the applied loads as the theoretical web bend-buckling stress is exceeded (Basler et al., 1960). Due to unavoidable geometric imperfections, the web bend-buckling behavior is a load-deflection rather than a bifurcation problem. The theoretical web-buckling load is used in these Specifications as a simple index for controlling the web plate bending strains and transverse displacements.

For a doubly-symmetric I-section without longitudinal web stiffeners, Eq. 6.10.1.9.1-2 gives $k = 36.0$, which is approximately equal to $k_{ss} + 0.8(k_{sf} - k_{ss})$, where $k_{ss} = 23.9$ and $k_{sf} = 39.6$ are the bend-buckling coefficients for simply-supported and fully restrained longitudinal edge conditions, respectively (Timoshenko and Gere, 1961). For I-sections in which $D_c \neq 0.5D$, Eq. 6.10.1.9.1-2 provides a reasonable approximation of theoretical bend-buckling resistance (Galambos, 1998) consistent with the above.

For composite sections subjected to positive flexure, these Specifications do not require the use of Eq. 6.10.1.9.1-1 after the section is in its final composite condition for webs that do not require longitudinal stiffeners based on Article 6.10.2.1.1. The section must be checked for web bend-buckling during construction while in the noncomposite condition. For loads applied at the fatigue and service limit states after the deck has hardened or is made composite, the increased compressive stresses in the web tend to be compensated for by the increase in F_{crw} resulting from the corresponding decrease in D_c . At the strength limit state, these compensating effects continue. Based on the section proportioning limits specified in Article 6.10.2 and the ductility requirement specified in Article 6.10.7.3, F_{crw} for these sections is generally close to or larger than F_{yc} at the strength limit state.

For composite sections in positive flexure in which longitudinal web stiffeners are required based on Article 6.10.2.1.1, the web slenderness requirement of Article 6.10.2.1.2 is not sufficient in general to ensure that theoretical bend-buckling of the web will not occur. Therefore, the Specifications require the calculation of R_b for these types of sections, as discussed further in Article C6.10.1.10.2.

For composite sections in negative flexure, D_c is to be computed using the section consisting of the steel girder

plus the longitudinal deck reinforcement, with the one possible exception noted at the service limit state in Article D6.3.1. This approach limits the potential complications in subsequent load rating resulting from the flexural resistance being a function of D_c and D_c being taken as a function of the applied load. This approach leads to a more conservative calculation of the flexural resistance, but the influence on the resistance is typically inconsequential.

Near points of permanent-load contraflexure, both edges of the web may be in compression when stresses in the steel and composite sections due to moments of opposite sign are accumulated. In this case, the neutral axis lies outside the web. Thus, the specification states that k be taken equal to 7.2 when both edges of the web are in compression, which is approximately equal to the theoretical bend-buckling coefficient for a web plate under uniform compression assuming fully restrained longitudinal edge conditions (Timoshenko and Gere, 1961). Such a case is relatively rare and the accumulated web compressive stresses are typically small when it occurs; however, this case may need to be considered in computer software.

6.10.1.9.2—Webs with Longitudinal Stiffeners

In lieu of an alternative rational analysis, the nominal bend-buckling resistance may be determined as specified in Eq. 6.10.1.9.1-1, with the bend-buckling coefficient taken as follows:

- If $\frac{d_s}{D_c} \geq 0.4$, then:

$$k = \frac{5.17}{(d_s/D)^2} \geq \frac{9}{(D_c/D)^2} \quad (6.10.1.9.2-1)$$

- If $\frac{d_s}{D_c} < 0.4$, then:

$$k = \frac{11.64}{\left(\frac{D_c - d_s}{D}\right)^2} \quad (6.10.1.9.2-2)$$

where:

d_s = distance from the centerline of the closest plate longitudinal stiffener or from the gage line of the closest angle longitudinal stiffener to the inner surface or leg of the compression-flange element (in.)

When both edges of the web are in compression, k shall be taken as 7.2.

C6.10.1.9.2

Eqs. 6.10.1.9.2-1 and 6.10.1.9.2-2 give an accurate approximation of the bend-buckling coefficient k for webs with a single longitudinal stiffener in any vertical location (Frank and Helwig, 1995). The resulting k depends on the location of the closest longitudinal web stiffener to the compression flange with respect to its optimum location at $d_s/D_c = 0.4$ (Vincent, 1969) and is used to determine the bend-buckling resistance from Eq. 6.10.1.9.1-1.

Changes in flange size cause D_c to vary along the length of a girder. In a composite girder, D_c is also a function of the applied load. If the longitudinal stiffener is located a fixed distance from the compression flange, which is normally the case, the stiffener cannot be at its optimum location throughout the girder length. In composite girders with longitudinally-stiffened webs subjected to positive flexure, D_c tends to be large for noncomposite loadings during construction and therefore web bend-buckling must be checked. Furthermore, D_c can be sufficiently large for the composite girder at the service limit state such that web bend-buckling may still be a concern. Therefore, the value of D_c for checking web bend-buckling of these sections in regions of positive flexure at the service limit state is to be determined based on the accumulated flexural stresses due to the factored loads, as specified in Article D6.3.1.

For composite sections in negative flexure, D_c is to be computed in the same manner as discussed in Article C6.10.1.9.1.

Eqs. 6.10.1.9.2-1 and 6.10.1.9.2-2 and the associated optimum stiffener location assume simply-supported boundary conditions at the flanges. These equations for k

allow the Engineer to compute the web bend-buckling resistance for any position of the longitudinal stiffener with respect to D_c . When the distance from the closest longitudinal stiffener to the compression flange, d_s , is less than $0.4D_c$, the stiffener is above its optimum location and web bend-buckling occurs in the panel between the stiffener and the tension flange. When d_s is greater than $0.4D_c$, web bend-buckling occurs in the panel between the stiffener and the compression flange. When d_s is equal to $0.4D_c$, the stiffener is at its optimum location and bend-buckling occurs in both panels. For this case, both equations yield a k value equal to 129.3 for a symmetrical girder (Dubas, 1948). Further information on locating longitudinal stiffeners on the web may be found in Article C6.10.11.3.1.

Since bend-buckling of a longitudinally-stiffened web must be investigated for both noncomposite and composite stress conditions and at various locations along the girder, it is possible that the stiffener might be located at an inefficient position for a particular condition, resulting in a small bend-buckling coefficient. Because simply-supported boundary conditions were assumed in the development of Eqs. 6.10.1.9.2-1 and 6.10.1.9.2-2, the computed web bend-buckling resistance for the longitudinally-stiffened web may be less than that computed for a web of the same dimensions without longitudinal stiffeners where some rotational restraint from the flanges has been assumed. To prevent this anomaly, the Specifications state that the k value for a longitudinally-stiffened web from Eq. 6.10.1.9.2-1 must equal or exceed a value of $9.0/(D_c/D)^2$, which is the k value for a web without longitudinal stiffeners from Eq. 6.10.1.9.1-2 computed assuming partial rotational restraint from the flanges. Note this limit only need be checked when Eq. 6.10.1.9.2-1 controls.

As discussed further in Article C6.10.1.9.1, when both edges of the web are in compression, the bend-buckling coefficient is taken equal to 7.2.

Eqs. 6.10.1.9.2-1 and 6.10.1.9.2-2 neglect the benefit of placing more than one longitudinal stiffener on the web. Therefore, they may be used conservatively for webs with multiple longitudinal stiffeners. Alternatively, the Engineer is permitted to determine F_{crw} of Eq. 6.10.1.9.1-1 or the corresponding k value for use within this equation by a direct buckling analysis of the web panel. The boundary conditions at the flanges and at the stiffener locations should be assumed as simply-supported in this analysis.

6.10.1.10—Flange-Strength Reduction Factors

6.10.1.10.1—Hybrid Factor, R_h

For rolled shapes, homogenous built-up sections and built-up sections with a higher-strength steel in the web than in both flanges, R_h shall be taken as 1.0. Otherwise, in lieu of an alternative rational analysis, the hybrid factor shall be taken as:

C6.10.1.10.1

The R_h factor accounts for the reduced contribution of the web to the nominal flexural resistance at first yield in any flange element, due to earlier yielding of the lower strength steel in the web of a hybrid section. As used herein, the term flange element is defined as a flange or cover plate or the longitudinal reinforcement.

$$R_h = \frac{12 + \beta(3\rho - \rho^3)}{12 + 2\beta} \quad (6.10.1.10.1-1)$$

in which:

$$\beta = \frac{2D_n t_w}{A_{fn}} \quad (6.10.1.10.1-2)$$

ρ = the smaller of F_{yw}/f_n and 1.0

where:

A_{fn} = sum of the flange area and the area of any cover plates on the side of the neutral axis corresponding to D_n (in.²). For composite sections in negative flexure, the area of the longitudinal reinforcement may be included in calculating A_{fn} for the top flange.

D_n = larger of the distances from the elastic neutral axis of the cross-section to the inside face of either flange (in.). For sections where the neutral axis is at the mid-depth of the web, the distance from the neutral axis to the inside face of the flange on the side of the neutral axis where yielding occurs first.

f_n = for sections where yielding occurs first in the flange, a cover plate or the longitudinal reinforcement on the side of the neutral axis corresponding to D_n , the largest of the specified minimum yield strengths of each component included in the calculation of A_{fn} (ksi). Otherwise, the largest of the elastic stresses in the flange, cover plate or longitudinal reinforcement on the side of the neutral axis corresponding to D_n at first yield on the opposite side of the neutral axis.

6.10.1.10.2—Web Load-Shedding Factor, R_b

When checking constructibility according to the provisions of Article 6.10.3.2, or when:

- the section is composite and is in positive flexure and the web satisfies the requirement of Article 6.10.2.1.1 or 6.11.2.1.2, as applicable,

or:

- one or more longitudinal stiffeners are provided and

$$\frac{D}{t_w} \leq 0.95 \sqrt{\frac{Ek}{F_{yc}}} \quad (6.10.1.10.2-1)$$

or:

Eq. 6.10.1.10.1-1 represents a condensation of the formulas for R_h in previous AASHTO Specifications and considers all possible combinations associated with different positions of the elastic neutral axis and different yield strengths of the top and bottom flange elements. The fundamental equation, originally derived for a doubly-symmetric I-section (ASCE, 1968; Schilling, 1968; and Frost and Schilling, 1964), is adapted in these provisions to handle singly-symmetric and composite sections by focusing on the side of the neutral axis where yielding occurs first. This side of the neutral axis has the most extensive web yielding prior to first yielding of any flange element. All flange elements on this side of the neutral axis are conservatively assumed to be located at the edge of the web. The equation is also adapted by assuming that the shift in the neutral axis due to the onset of web yielding is negligible. These assumptions are similar to those used in the development of a separate R_h equation for composite sections in prior AASHTO Specifications. In lieu of the approximate Eq. 6.10.1.10.1-1, the Engineer may determine R_h based on a direct iterative strain-compatibility analysis. Since the computed R_h values by any approach are typically close to 1.0, the conservative assumptions made in the derivation of the simplified single noniterative Eq. 6.10.1.10.1-1 should not result in a significant economic penalty.

For composite sections in positive flexure, D_n may be taken conservatively as the distance from the neutral axis of the short-term composite section to the inside face of the bottom flange. This approach is strongly recommended to prevent possible complications in subsequent load rating resulting from the flexural resistance being a function of D_n and D_n being a function of the applied load.

For composite sections where the neutral axis is at the mid-depth of the web and where first yield occurs simultaneously in both flange elements, D_n should be taken as the distance to the flange element with the smaller A_{fn} .

C6.10.1.10.2

The term R_b is a postbuckling strength reduction factor that accounts for the nonlinear variation of stresses subsequent to local bend-buckling of slender webs. This factor accounts for the reduction in the section flexural resistance caused by the shedding of compressive stresses from a slender web and the corresponding increase in the flexural stress within the compression flange. The R_b factor given by Eq. 6.10.1.10.2-3 is based on extensive experimental and theoretical studies (Galambos, 1998) and is the more refined of two equations developed by Basler and Thurlimann (1961). The R_b factor is not applied in determining the nominal flexural resistance of the tension flange since the tension flange stress is not increased significantly by the shedding of the web compressive stresses (Basler and Thurlimann, 1961).

- the webs satisfy:

$$\frac{2D_c}{t_w} \leq \lambda_{rw} \quad (6.10.1.10.2-2)$$

Then, R_b shall be taken as 1.0.

Otherwise:

$$R_b = 1 - \left(\frac{a_{wc}}{1200 + 300a_{wc}} \right) \left(\frac{2D_c}{t_w} - \lambda_{rw} \right) \leq 1.0 \quad (6.10.1.10.2-3)$$

in which:

λ_{rw} = limiting slenderness ratio for a noncompact web

$$= 5.7 \sqrt{\frac{E}{F_{yc}}} \quad (6.10.1.10.2-4)$$

a_{wc} = for all sections except as noted below, ratio of two times the web area in compression to the area of the compression flange

$$= \frac{2D_c t_w}{b_{fc} t_{fc}} \quad (6.10.1.10.2-5)$$

for composite longitudinally-stiffened sections in positive flexure

$$= \frac{2D_c t_w}{b_{fc} t_{fc} + b_s t_s (1 - f_{DC1} / F_{yc}) / 3n} \quad (6.10.1.10.2-6)$$

where:

- b_s = effective width of concrete deck (in.)
- f_{DC1} = compression flange stress at the section under consideration, calculated without consideration of flange lateral bending and caused by the factored permanent load applied before the concrete deck has hardened or is made composite (ksi)
- k = bend-buckling coefficient for webs with longitudinal stiffeners determined as specified in Article 6.10.1.9.2
- n = modular ratio determined as specified in Article 6.10.1.1.1b
- t_s = thickness of concrete deck (in.)
- D_c = depth of the web in compression in the elastic range (in.). For composite sections, D_c shall be determined as specified in Article D6.3.1.

When computing the nominal flexural resistance of the compression flange for checking constructibility according to the provisions of Article 6.10.3.2, R_b is always to be taken equal to 1.0. This condition is ensured in these Specifications for all slender-web sections by limiting the compression-flange flexural stresses under the factored loads during construction to the elastic bend-buckling resistance of the web, F_{crw} .

For composite sections in positive flexure at the strength limit state, R_b is generally equal to or close to 1.0 for sections that satisfy the requirements of Articles 6.10.2.2 and 6.10.7.3, as long as the requirement of Article 6.10.2.1.1 is also met such that longitudinal stiffeners are not required. This is particularly true when a transformed area of the concrete deck is taken as part of the compression flange area as implemented in Eq. 6.10.1.10.2-6. Therefore, the reduction in the flexural resistance due to web bend-buckling is zero or negligible and R_b is simply taken equal to 1.0 for these sections.

For sections in positive or negative flexure with one or more longitudinal web stiffeners that satisfy Eq. 6.10.1.10.2-1, R_b is taken equal to 1.0. For these sections, the web slenderness, D/t_w , is at or below the value at which the theoretical bend-buckling stress at the strength limit state is equal to F_{yc} . For a doubly-symmetric girder, i.e., $D_c = 0.5D$, with a single longitudinal stiffener located at the optimum position on the web, this limit is as follows for different grades of steel:

Table C6.10.1.10.2-1—Limiting Slenderness Ratio for $R_b = 1.0$ in a Longitudinally-Stiffened Girder with the Stiffener at the Optimum Location and $D_c/D = 0.5$

F_{yc} (ksi)	$0.95 \sqrt{\frac{Ek}{F_{yc}}}$
36.0	300
50.0	260
70.0	220
90.0	194
100.0	184

For monosymmetric girders with $D_c/D > 0.5$ and/or where a single longitudinal stiffener is not located at its optimum position, the limiting D/t_w from Eq. 6.10.1.10.2-1 generally will be less than the value shown in Table C6.10.1.10.2-1.

For composite sections in regions of positive flexure, the concrete deck typically contributes a large fraction of the flexural resistance as a compression-flange element. For longitudinally-stiffened sections of this type, Eq. 6.10.1.10.2-6 accounts for this contribution conservatively in the calculation of R_b by including a fraction of the transformed deck area based on the $3n$

section with the steel compression-flange area in computing the a_{wc} term. D_c in Eq. 6.10.1.10.2-6 is to be computed as specified for composite sections in positive flexure in Article D6.3.1 and is a function of the applied loads. The relationship of the position of the longitudinal stiffener to D_c and the resulting effect on the web bend-buckling coefficient, k , is discussed further in Articles C6.10.1.9.2 and C6.10.11.3.1. For the preliminary design of longitudinally-stiffened sections of this type in which R_b is anticipated to be less than 1.0, a value of R_b typically between 0.85 and 0.95 can be assumed. Members with larger dead-to-live load ratios will tend to fall on the lower end of this range. This preliminary value of R_b can then be refined later in the design using Eq. 6.10.1.10.2-3. In cases where R_b is equal to 1.0 for these sections, potential difficulties during load rating associated with the dependency of the flexural resistance on D_c and the dependency of D_c on the applied loading are avoided.

Eq. 6.10.1.10.2-1 ignores the beneficial effect of placing more than one longitudinal stiffener on the web. For webs with more than one longitudinal stiffener, the girder may be proportioned for $R_b = 1.0$ if F_{crw} , determined by an alternative rational analysis conducted as specified in Article C6.10.1.9.2, is greater than or equal to F_{yc} .

The requirements for proportioning of longitudinal stiffeners in Article 6.10.11.3 ensure the development of the web bend-buckling resistance specified in Article 6.10.1.9. Bend buckling of longitudinally-stiffened webs is prevented up through the service limit state in these Specifications, but is permitted at the strength limit state. The stiffener proportioning requirements do not ensure that a horizontal line of near zero lateral deflection will be maintained for the subsequent post-bend-buckling response of the web (Galambos, 1998). Therefore, the presence of the longitudinal stiffeners is ignored when computing the R_b factor for longitudinally-stiffened webs in regions of positive or negative flexure at the strength limit state.

For composite sections in negative flexure and noncomposite sections that satisfy Eq. 6.10.1.10.2-2, R_b is also taken equal to 1.0 since the web slenderness, $2D_c/t_w$, is at or below the value at which the theoretical elastic bend-buckling stress is equal to F_{yc} at the strength limit state. Eq. 6.10.1.10.2-2 also defines the slenderness limit for a noncompact web. Webs with slenderness ratios exceeding Eq. 6.10.1.10.2-2 are termed slender. For different grades of steel, this slenderness limit is as follows:

Table C6.10.1.10.2-2—Limiting Slenderness Ratio for a Noncompact Web and $R_b = 1.0$ in Girders without Web Longitudinal Stiffeners

F_{yc} (ksi)	λ_{rw}
36.0	162
50.0	137
70.0	116
90.0	102
100.0	97

The previous Specifications defined sections as compact or noncompact and did not explicitly distinguish between a noncompact and a slender web. The classification of webs as compact, noncompact, or slender in these Specifications apply to composite sections in negative flexure and noncomposite sections. These classifications are consistent with those in AISC (2005). For composite sections in positive flexure, these Specifications still classify the entire cross-section as compact or noncompact based on the criteria in Article 6.10.6.2.2. The Article 6.10.6.2.2 classification includes consideration of the web slenderness as well as other cross-section characteristics.

For the preliminary design of slender-web sections without longitudinal stiffeners, a value of R_b typically between 0.9 and 1.0 can be assumed, depending on an estimated $2D_c/t_w$ relative to the appropriate limiting value given in Table C6.10.1.10.2-2. A value typically between 0.85 and 0.95 should be assumed for longitudinally-stiffened slender-web sections anticipated to have D/t_w values that will not satisfy Eq. 6.10.1.10.2-1. This preliminary value of R_b can be refined later in the design using Eq. 6.10.1.10.2-3.

For composite sections in negative flexure, D_c is to be computed for the section consisting of the steel girder plus the longitudinal deck reinforcement when determining R_b for reasons discussed in Article C6.10.1.9.1.

The factor 5.7 in Eq. 6.10.1.10.2-4 is based on a bend-buckling coefficient $k = 36.0$, which is approximately equal to $k_{ss} + 0.8(k_{sf} - k_{ss})$, where $k_{ss} = 23.9$ and $k_{sf} = 39.6$ are the bend-buckling coefficients for simply-supported and fully restrained longitudinal edge conditions, respectively, in webs without longitudinal stiffeners (Timoshenko and Gere, 1961).

For compression flanges with cover plates, the cover plate area may be added to the flange area $b_{fc}t_{fc}$ in the denominator of Eq. 6.10.1.10.2-5.

While it is possible to substitute the actual compression-flange stress due to the factored loads, f_{bu} , calculated without consideration of flange lateral bending, for F_{yc} in Eqs. 6.10.1.10.2-1, 6.10.1.10.2-4, and 6.10.1.10.2-6, such a refinement is not likely to lead to a significant increase in the value of R_b . Use of the actual flange stress to compute the flexural resistance can also lead to subsequent difficulties in load rating since the

flexural resistance then becomes a function of the applied load. Should a larger value of R_b be desired for a section in which the nominal flexural resistance of the compression flange is significantly less than F_{yc} , a preferred alternative is to substitute the smaller of the following values for F_{yc} in Eqs. 6.10.1.10.2-1, 6.10.1.10.2-4, and 6.10.1.10.2-6, as applicable: (1) the nominal flexural resistance of the compression flange, F_{nc} , computed assuming R_b and R_h are equal to 1.0, or (2) the nominal elastic stress in the compression flange when the tension flange reaches a nominal elastic stress of $R_h F_{yt}$. This is similar to the approach taken in AISC (1999).

6.10.2—Cross-Section Proportion Limits

6.10.2.1—Web Proportions

6.10.2.1.1—Webs without Longitudinal Stiffeners

C6.10.2.1.1

Webs shall be proportioned such that:

$$\frac{D}{t_w} \leq 150 \quad (6.10.2.1.1-1)$$

Eq. 6.10.2.1.1-1 is a practical upper limit on the slenderness of webs without longitudinal stiffeners expressed in terms of the web depth, D . This equation allows for easier proportioning of the web in preliminary design relative to previous Specifications. In previous Specifications, Eq. 6.10.2.1.1-1 was the upper limit for unstiffened webs. By also limiting the slenderness of transversely-stiffened webs to this value, maximum transverse stiffener spacings up to $3D$ are permitted; the requirement in previous Specifications to provide additional transverse stiffeners for handling in girders with more slender webs, beyond those required for shear, is eliminated. Furthermore, satisfaction of Eq. 6.10.2.1.1-1 allows web bend-buckling to be disregarded in the design of composite sections in positive flexure, as discussed further in Article C6.10.1.9.1. The limit in Eq. 6.10.2.1.1-1 is valid for sections with specified minimum yield strengths up to and including 100.0 ksi designed according to these Specifications.

The vertical flange buckling limit-state equations in AISC (2005), which are based in large part on ASCE (1968), are not considered in these Specifications. These equations specify a limit on the web slenderness to prevent theoretical elastic buckling of the web as a column subjected to a radial transverse compression due to the curvature of the flanges. For girders that satisfy Eq. 6.10.2.1.1-1, these equations do not govern the web slenderness unless F_{yc} is greater than 85.0 ksi. Furthermore, tests conducted by Lew and Toprac (1968), Cooper (1967), and others, in which the final failure mode involved vertical flange buckling, or a folding of the compression flange vertically into the web, indicate that the influence of this failure mode on the predicted girder flexural resistances is small. This is the case even for girders with parameters that significantly violate the vertical flange buckling limit-state equations.

6.10.2.1.2—Webs with Longitudinal Stiffeners

C6.10.2.1.2

Webs shall be proportioned such that:

$$\frac{D}{t_w} \leq 300 \quad (6.10.2.1.2-1)$$

Eq. 6.10.2.1.2-1 is a practical upper limit on the slenderness of webs with longitudinal stiffeners expressed in terms of the web depth, D . This limit allows for easier proportioning of the web for preliminary design than comparable limits in previous Specifications. The limit in Eq. 6.10.2.1.2-1 is valid for sections with specified minimum yield strengths up to and including 100.0 ksi designed according to these Specifications.

Cooper (1967) discusses the conservatism of vertical flange buckling limit-state equations and the justification for not considering this limit state in longitudinally-stiffened I-girders. Tests by Cooper (1967), Owen et al. (1970) and others have demonstrated that the flexural resistance is not adversely affected by final failure modes involving vertical flange buckling, even for longitudinally-stiffened girders that significantly exceed the limit of Eq. 6.10.2.1.2-1. In all cases involving a vertical flange buckling type of failure, extensive flexural yielding of the compression flange preceded the failure. However, webs that have larger D/t_w values than specified by Eq. 6.10.2.1.2-1 are relatively inefficient, are likely to be more susceptible to distortion-induced fatigue, and are more susceptible to the limit states of web crippling and web yielding of Article D6.5.

6.10.2.2—Flange Proportions

C6.10.2.2

Compression and tension flanges shall be proportioned such that:

$$\frac{b_f}{2t_f} \leq 12.0, \quad (6.10.2.2-1)$$

$$b_f \geq D/6, \quad (6.10.2.2-2)$$

$$t_f \geq 1.1t_w, \quad (6.10.2.2-3)$$

and:

$$0.1 \leq \frac{I_{yc}}{I_{yt}} \leq 10 \quad (6.10.2.2-4)$$

where:

I_{yc} = moment of inertia of the compression flange of the steel section about the vertical axis in the plane of the web (in.⁴)

Eq. 6.10.2.2-1 is a practical upper limit to ensure the flange will not distort excessively when welded to the web.

White and Barth (1998) observe that the cross-section aspect ratio D/b_f is a significant parameter affecting the strength and moment-rotation characteristics of I-sections. Eq. 6.10.2.2-2 limits this ratio to a maximum value of 6. Experimental test data are limited for sections with very narrow flanges. A significant number of the limited tests that have been conducted have indicated relatively low nominal flexural and shear resistances relative to the values determined using these and previous Specifications. Limiting this ratio to a maximum value of 6 for both the compression and tension flanges ensures that stiffened interior web panels, with the section along the entire panel proportioned to satisfy Eq. 6.10.9.3.2-1, can develop postbuckling shear resistance due to tension-field action (White et al., 2004). Eq. 6.10.2.2-2 provides a lower limit on the flange width. In most practical cases, a wider flange will be required, particularly for horizontally curved girders. Note that Eq. C6.10.3.4-1 should be also considered, as applicable, in conjunction with these flange proportion limits to establish appropriate minimum flange widths.

Eq. 6.10.2.2-3 ensures that some restraint will be provided by the flanges against web shear buckling, and also that the boundary conditions assumed at the web-flange juncture in the web bend-buckling and compression-flange local buckling formulations within these Specifications are sufficiently accurate. The ratio of the web area to the

I_{yt} = moment of inertia of the tension flange of the steel section about the vertical axis in the plane of the web (in.⁴)

compression flange area is always less than or equal to 5.45 for members that satisfy Eqs. 6.10.2.2-2 and 6.10.2.2-3. Therefore, the AISC (2005) limit of 10 on this ratio is not required.

An I-section with a ratio of I_{yc}/I_{yt} outside the limits specified in Eq. 6.10.2.2-4 is more like a tee-section with the shear center located at the intersection of the larger flange and the web. The limits of Eq. 6.10.2.2-4 are similar to the limits specified in previous Specifications, but are easier to apply since they are based on the ratio of I_{yc} to I_{yt} rather than to I_y of the entire steel section. Eq. 6.10.2.2-4 ensures more efficient flange proportions and prevents the use of sections that may be particularly difficult to handle during construction. Also, Eq. 6.10.2.2-4 ensures the validity of the equations for $C_b > 1$ in cases involving moment gradients. Furthermore, these limits tend to prevent the use of extremely monosymmetric sections for which the larger of the yield moments, M_{yc} or M_{yt} , may be greater than the plastic moment, M_p . If the flanges are composed of plates of equal thickness, these limits are equivalent to $b_{fc} \geq 0.46b_{ft}$ and $b_{fc} \leq 2.15 b_{ft}$.

The advent of composite design has led to a significant reduction in the size of compression flanges in regions of positive flexure. In addition to satisfying the proportion limits given in this Article, the minimum compression-flange width in these regions for preliminary design should also be established based on the L/b_{fc} guideline suggested in Eq. C6.10.3.4-1.

6.10.3—Constructibility

6.10.3.1—General

The provisions of Article 2.5.3 shall apply. In addition to providing adequate strength, nominal yielding or reliance on post-buckling resistance shall not be permitted for main load-carrying members during critical stages of construction, except for yielding of the web in hybrid sections. This shall be accomplished by satisfying the requirements of Articles 6.10.3.2 and 6.10.3.3 at each critical construction stage. For sections in positive flexure that are composite in the final condition, but are noncomposite during construction, the provisions of Article 6.10.3.4 shall apply. For investigating the constructibility of flexural members, all loads shall be factored as specified in Article 3.4.2. For the calculation of deflections, the load factors shall be taken as 1.0.

Potential uplift at bearings shall be investigated at each critical construction stage.

Webs without bearing stiffeners at locations subjected to concentrated loads not transmitted through a deck or deck system shall satisfy the provisions of Article D6.5.

If there are holes in the tension flange at the section under consideration, the tension flange shall also satisfy the requirement specified in Article 6.10.1.8.

Load-resisting bolted connections either in or to flexural members shall be proportioned to prevent slip under the factored loads at each critical construction stage.

C6.10.3.1

If uplift is indicated at any critical stage of construction, temporary load may be placed to prevent lift-off. The magnitude and position of any required temporary load should be provided in the contract documents.

Factored forces at high-strength bolted joints of load carrying members are limited to the slip resistance of the connection during each critical construction state to ensure that the correct geometry of the structure is maintained.

The provisions of Article 6.13.2.8 shall apply for investigation of connection slip.

6.10.3.2—Flexure

6.10.3.2.1—Discretely Braced Flanges in Compression

For critical stages of construction, each of the following requirements shall be satisfied. For sections with slender webs, Eq. 6.10.3.2.1-1 shall not be checked when f_ℓ is equal to zero. For sections with compact or noncompact webs, Eq. 6.10.3.2.1-3 shall not be checked.

$$f_{bu} + f_\ell \leq \phi_f R_h F_{yc}, \quad (6.10.3.2.1-1)$$

$$f_{bu} + \frac{1}{3} f_\ell \leq \phi_f F_{nc}, \quad (6.10.3.2.1-2)$$

and

$$f_{bu} \leq \phi_f F_{crw} \quad (6.10.3.2.1-3)$$

where:

- ϕ_f = resistance factor for flexure specified in Article 6.5.4.2.
- f_{bu} = flange stress calculated without consideration of flange lateral bending determined as specified in Article 6.10.1.6 (ksi)
- f_ℓ = flange lateral bending stress determined as specified in Article 6.10.1.6 (ksi)
- F_{crw} = nominal bend-buckling resistance for webs specified in Article 6.10.1.9 (ksi)
- F_{nc} = nominal flexural resistance of the flange (ksi). F_{nc} shall be determined as specified in Article 6.10.8.2. For sections in straight I-girder bridges with compact or noncompact webs, the lateral torsional buckling resistance may be taken as M_{nc} determined as specified in Article A6.3.3 divided by S_{xc} . In computing F_{nc} for constructibility, the web load-shedding factor, R_b , shall be taken as 1.0.
- M_{yc} = yield moment with respect to the compression flange determined as specified in Article D6.2 (kip-in.)
- R_h = hybrid factor specified in Article 6.10.1.10.1. For hybrid sections in which f_{bu} does not exceed the specified minimum yield strength of the web, the hybrid factor shall be taken equal to 1.0.
- S_{xc} = elastic section modulus about the major axis of the section to the compression flange taken as M_{yc}/F_{yc} (in.³)

C6.10.3.2.1

A distinction is made between discretely and continuously braced compression and tension flanges because for a continuously braced flange, flange lateral bending need not be considered.

This Article gives constructibility requirements for discretely braced compression flanges, expressed by Eqs. 6.10.3.2.1-1, 6.10.3.2.1-2, and 6.10.3.2.1-3 in terms of the combined factored vertical and flange lateral bending stresses during construction. In making these checks, the stresses f_{bu} and f_ℓ must be determined according to the procedures specified in Article 6.10.1.6.

Eq. 6.10.3.2.1-1 ensures that the maximum combined stress in the compression flange will not exceed the specified minimum yield strength of the flange times the hybrid factor; that is, it is a yielding limit state check.

Eq. 6.10.3.2.1-2 ensures that the member has sufficient strength with respect to lateral torsional and flange local buckling based limit states, including the consideration of flange lateral bending where these effects are judged to be significant. For horizontally curved bridges, flange lateral bending effects due to curvature must always be considered in discretely braced flanges during construction.

Eq. 6.10.3.2.1-3 ensures that theoretical web bend-buckling will not occur during construction.

Eq. 6.10.3.2.1-2 addresses the resistance of the compression flange by considering this element as an equivalent beam-column. This equation is effectively a beam-column interaction equation, expressed in terms of the flange stresses computed from elastic analysis (White and Grubb, 2005). The f_{bu} term is analogous to the axial load and the f_ℓ term is analogous to the bending moment within the equivalent beam-column member. The factor of 1/3 in front of the f_ℓ term in Eq. 6.10.3.2.1-2 gives an accurate linear approximation of the equivalent beam-column resistance within the limits on f_ℓ specified in Article 6.10.1.6 (White and Grubb, 2005).

Eq. 6.10.3.2.1-1 often controls relative to Eq. 6.10.3.2.1-2, particularly for girders with large f_ℓ and for members with compact or noncompact webs. However, for members with noncompact flanges or large unsupported lengths during construction combined with small or zero values for f_ℓ , Eq. 6.10.3.2.1-2 will typically control. During construction before the hardening of the deck, most flanges are discretely braced. The compact, noncompact and slender web definitions are discussed in Article C6.10.6.2.3. For making these checks with the section in its noncomposite condition, the categorization of the web is to be based on the

properties of the noncomposite section. The meanings assigned to the compact and noncompact flange categorizations are discussed in Article C6.10.8.2.2. When $f_t = 0$, Eq. 6.10.3.2.1-1 will not control and need not be checked for sections with slender webs. For sections with compact or noncompact webs, Eq. 6.10.3.2.1-1 should still be checked. However, web bend-buckling is not a consideration for these types of members, and therefore, Eq. 6.10.3.2.1-3 need not be checked for these sections.

In checking Eq. 6.10.3.2.1-2 for sections in straight I-girder bridges with compact or noncompact webs, the lateral torsional buckling resistance of the flange may be determined from the provisions of Article A6.3.3, which include the beneficial contribution of the St. Venant torsional constant J . This may be useful for sections in such bridges with compact or noncompact webs having larger unbraced lengths, if additional lateral torsional buckling resistance is required beyond that calculated based on the provisions of Article 6.10.8.2. The resulting lateral torsional buckling resistance, M_{nc} , is then divided by S_{xc} to express the resistance in terms of stress for direct application in Eq. 6.10.3.2.1-2. In some cases, the calculated resistance will exceed F_{yc} since Appendix A6 accounts in general for flexural resistances greater than the yield moment resistance, M_{yc} or M_{yr} . However, Eq. 6.10.3.2.1-1 will control in these cases, thus ensuring that the combined factored stress in the flange will not exceed F_{yc} times the hybrid factor during construction.

The rationale for calculation of S_{xc} , as defined in this Article for use in determining F_{nc} for sections with noncompact or compact webs, is discussed in Article CA6.1.1.

For sections that are composite in the final condition, but are noncomposite during construction, different values of the hybrid factor, R_h , must be calculated for checks in which the member is noncomposite and for checks in which the member is composite.

Because the flange stress is limited to the web bend-buckling stress according to Eq. 6.10.3.2.1-3, the R_b factor is always to be taken equal to 1.0 in computing the nominal flexural resistance of the compression flange for constructibility.

Should the web bend-buckling resistance be exceeded for the construction condition, the Engineer has several options to consider. These options include providing a larger compression flange or a smaller tension flange to decrease the depth of the web in compression, adjusting the deck-placement sequence to reduce the compressive stress in the web, or providing a thicker web. Should these options not prove to be practical or cost-effective, a longitudinal web stiffener can be provided. As specified in Article 6.10.11.3.1, the longitudinal stiffener must be located vertically on the web to satisfy Eq. 6.10.3.2.1-3 for the construction condition, Eq. 6.10.4.2.2-4 at the service limit state and all the appropriate design requirements at the strength limit state. Further discussions of procedures

for locating a longitudinal stiffener are provided in Article C6.10.11.3.1.

6.10.3.2.2—Discretely Braced Flanges in Tension

C6.10.3.2.2

For critical stages of construction, the following requirement shall be satisfied:

$$f_{bu} + f_{\ell} \leq \phi_f R_h F_{yt} \quad (6.10.3.2.2-1)$$

For a discretely braced flange in tension, Eq. 6.10.3.2.2-1 ensures that the stress in the flange will not exceed the specified minimum yield strength of the flange times the hybrid factor during construction under the combination of the major-axis bending and lateral bending stresses due to the factored loads.

6.10.3.2.3 Continuously Braced Flanges in Tension or Compression

C6.10.3.2.3

For critical stages of construction, the following requirement shall be satisfied:

$$f_{bu} \leq \phi_f R_h F_{yf} \quad (6.10.3.2.3-1)$$

For noncomposite sections with slender webs, flanges in compression shall also satisfy Eq. 6.10.3.2.1-3.

This Article assumes that a continuously braced flange in compression is not subject to local or lateral torsional buckling. Article C6.10.1.6 states the conditions for which a flange may be considered to be continuously braced. By encasing the flange in concrete or by attaching the flange to the concrete deck by shear connectors that satisfy the requirements of Article 6.10.10, one side of the flange is effectively prevented from local buckling, or both sides of the flange must buckle in the direction away from the concrete deck. Therefore, highly restrained boundary conditions are provided in effect at the web-flange juncture. Also, the flange lateral bending deflections, required to obtain a significant reduction in strength associated with flange local buckling, are effectively prevented by the concrete deck. Therefore, neither flange local nor lateral torsional buckling need to be checked for compression flanges that satisfy the proportioning limits of Article 6.10.2.2 and are continuously braced according to the conditions stated in Article C6.10.1.6.

6.10.3.2.4—Concrete Deck

C6.10.3.2.4

The longitudinal tensile stress in a composite concrete deck due to the factored loads shall not exceed $\phi_f f_r$ during critical stages of construction, unless longitudinal reinforcement is provided according to the provisions of Article 6.10.1.7. The concrete stress shall be determined as specified in Article 6.10.1.1.1d. ϕ and f_r shall be taken as specified in Article 6.10.1.7.

This Article is intended to address primarily the situation when the concrete deck is placed in a span adjacent to a span where the concrete has already been placed. Negative moment in the adjacent span causes tensile stresses in the previously placed concrete. Also, if long placements are made such that a negative flexure region is included in the first placement, it is possible that the concrete in this region will be stressed in tension during the remainder of the deck placement, which may lead to early cracking of the deck. When the longitudinal tensile stress in the deck exceeds the factored modulus of rupture of the concrete, longitudinal reinforcement is to be provided according to the provisions of Article 6.10.1.7 to control the cracking. Stresses in the concrete deck are to be computed using the short-term modular ratio, n , per Article 6.10.1.1.1d.

6.10.3.3—Shear

Webs shall satisfy the following requirement during critical stages of construction:

$$V_u \leq \phi_v V_{cr} \quad (6.10.3.3-1)$$

where:

ϕ_v = resistance factor for shear specified in Article 6.5.4.2

V_u = shear in the web at the section under consideration due to the factored permanent loads and factored construction loads applied to the noncomposite section (kip)

V_{cr} = shear-buckling resistance determined from Eq. 6.10.9.3.3-1 (kip)

6.10.3.4—Deck Placement

Sections in positive flexure that are composite in the final condition, but are noncomposite during construction, shall be investigated for flexure according to the provisions of Article 6.10.3.2 during the various stages of the deck placement.

Geometric properties, bracing lengths and stresses used in calculating the nominal flexural resistance shall be for the steel section only. Changes in load, stiffness and bracing during the various stages of the deck placement shall be considered.

The effects of forces from deck overhang brackets acting on the fascia girders shall be considered.

C6.10.3.3

The web is to be investigated for the sum of the factored permanent loads and factored construction loads applied to the noncomposite section during construction. The nominal shear resistance for this check is limited to the shear yielding or shear-buckling resistance per Eq. 6.10.9.3.3-1. The use of tension-field action per Eq. 6.10.9.3.2-2 is not permitted under these loads during construction. Use of tension-field action is permitted after the deck has hardened or is made composite, if the section along the entire panel is proportioned to satisfy Eq. 6.10.9.3.2-1.

C6.10.3.4

The entire concrete deck may not be placed in one stage; thus, parts of the girders may become composite in sequential stages. If certain deck placement sequences are followed, the temporary moments induced in the girders during the deck placement can be considerably higher than the final noncomposite dead load moments after the sequential placement is complete.

Economical composite girders normally have smaller top flanges than bottom flanges. Thus, more than half the web depth is typically in compression in regions of positive flexure during deck placement. If the maximum moments generated during the deck placement sequence are not considered in the design, these conditions, coupled with narrow top compression flanges, can lead to problems during construction, such as out-of-plane distortions of the girder compression flanges and web. By satisfying the following guideline:

$$b_{fc} \geq \frac{L}{85} \quad (C6.10.3.4-1)$$

where:

L = length of the girder shipping piece (in.),

potential problems can be minimized in these cases. Therefore, Eq. C6.10.3.4-1 should be used, in conjunction with the flange proportion limits specified in Article 6.10.2.2, to establish a minimum required top-flange width in positive-flexure regions of composite girders. It should be emphasized that Eq. C6.10.3.4-1 is provided merely as a guideline and is not an absolute requirement.

Ensuring that the flanges of all anticipated lifting pieces generally satisfy the preceding guideline over the majority of the length of each piece can also help provide more stable pieces that are easier to handle during erection without the need for special stiffening trusses or falsework.

Sequentially staged concrete placement can also result in significant tensile strains in the previously placed deck in adjacent spans. When cracking is predicted, longitudinal deck reinforcement as specified in Article 6.10.3.2.4 is required to control the cracking. Temporary dead load deflections during sequential deck placement can also be different from final noncomposite dead load deflections. If the differences are deemed significant, this should be considered when establishing camber and screed requirements. These constructibility concerns apply to deck replacement as well as initial construction.

During construction of steel girder bridges, concrete deck overhang loads are typically supported by cantilever forming brackets typically placed at 3.0 to 4.0 ft spacings along the exterior members. The eccentricity of the deck weight and other loads acting on the overhang brackets creates applied torsional moments on the exterior members. As a result, the following issues must be considered in the design of the exterior members:

- The applied torsional moments bend the exterior girder top flanges outward. The resulting flange lateral bending stresses tend to be largest at the brace points at one or both ends of the unbraced length. The lateral bending stress in the top flange is tensile at the brace points on the side of the flange opposite from the brackets. These lateral bending stresses should be considered in the design of the flanges.
- The horizontal components of the reactions on the cantilever-forming brackets are often transmitted directly onto the exterior girder web. The girder web may exhibit significant plate bending deformations due to these loads. The effect of these deformations on the vertical deflections at the outside edge of the deck should be considered. The effect of the reactions from the brackets on the cross-frame forces should also be considered.
- Excessive deformation of the web or top flange may lead to excessive deflection of the bracket supports causing the deck finish to be problematic.

Where practical, forming brackets should be carried to the intersection of the bottom flange and the web. Alternatively, the brackets may bear on the girder webs if means are provided to ensure that the web is not damaged and that the associated deformations permit proper placement of the concrete deck. The provisions of Article 6.10.3.2 allow for the consideration of the flange lateral bending stresses in the design of the flanges. In the absence of a more refined analysis, either of the following equations may be used to estimate the maximum flange lateral bending moments due to the eccentric loadings depending on how the lateral load is assumed applied to the top flange:

$$M_{\ell} = \frac{F_{\ell} L_b^2}{12} \quad (\text{C6.10.3.4-2})$$

where:

- M_{ℓ} = lateral bending moment in the flanges due to the eccentric loadings from the forming brackets (kip-in.)
- F_{ℓ} = statically equivalent uniformly distributed lateral force from the brackets due to the factored loads (kip/in.)
- L_b = unbraced length (in.)

$$M_{\ell} = \frac{P_{\ell} L_b}{8} \quad (\text{C6.10.3.4-3})$$

where:

- P_{ℓ} = statically equivalent concentrated lateral bracket force placed at the middle of the unbraced length (kip)

Eqs. C6.10.3.4-2 and C6.10.3.4-3 are both based on the assumption of interior unbraced lengths in which the flange is continuous with adjacent unbraced lengths, as well as equal adjacent unbraced lengths such that due to approximate symmetry boundary conditions, the ends of the unbraced length are effectively torsionally fixed. The Engineer should consider other more appropriate idealizations when these assumptions do not approximate the actual conditions.

Construction dead loads, such as those acting on the deck overhangs, are often applied to the noncomposite section and removed when the bridge has become composite. Typically, the major-axis bending moments due to these loads are small relative to other design loads. However, the Engineer may find it desirable in some cases to consider the effect of these moments, particularly in computing deflections for cambers. The lateral bending moments due to overhang loads not applied through the shear center of the girder are often more critical. Refined analysis of the noncomposite bridge for these loads provides more accurate lateral moments and may identify any rotation of the overhang that could potentially affect the elevation of the screed when finishing the deck.

The magnitude and application of the overhang loads assumed in the design should be shown in the contract documents.

6.10.3.5—Dead Load Deflections

The provisions of Article 6.7.2 shall apply, as applicable.

C6.10.3.5

If staged construction is specified, the sequence of load application should be recognized in determining the camber and stresses.

6.10.4—Service Limit State**6.10.4.1—Elastic Deformations**

The provisions of Article 2.5.2.6 shall apply, as applicable.

6.10.4.2—Permanent Deformations*6.10.4.2.1—General*

For the purposes of this Article, the Service II load combination specified in Table 3.4.1-1 shall apply.

The following methods may be used to calculate stresses in structural steel at the Service II limit state:

- For members with shear connectors provided throughout their entire length that also satisfy the provisions of Article 6.10.1.7, flexural stresses in the structural steel caused by Service II loads applied to the composite section may be computed using the short-term or long-term composite section, as appropriate. The concrete deck may be assumed to be effective for both positive and negative flexure, provided that the maximum longitudinal tensile stresses in the concrete deck at the section under consideration caused by the Service II loads are smaller than $2f_r$, where f_r is the modulus of rupture of the concrete specified in Article 6.10.1.7.
- For sections that are composite for negative flexure with maximum longitudinal tensile stresses in the concrete deck greater than or equal to $2f_r$, the flexural stresses in the structural steel caused by Service II loads shall be computed using the section consisting of the steel section and the longitudinal reinforcement within the effective width of the concrete deck.
- For sections that are noncomposite for negative flexure, the properties of the steel section alone shall be used for calculation of the flexural stresses in the structural steel.

The longitudinal stresses in the concrete deck shall be determined as specified in Article 6.10.1.1.d.

6.10.4.2.2—Flexure

Flanges shall satisfy the following requirements:

- For the top steel flange of composite sections:

$$f_f \leq 0.95R_h F_{yf} \quad (6.10.4.2.2-1)$$

- For the bottom steel flange of composite sections:

C6.10.4.1

The provisions of Article 2.5.2.6 contain optional live load deflection criteria and criteria for span-to-depth ratios. In the absence of depth restrictions, the span-to-depth ratios should be used to establish a reasonable minimum web depth for the design.

C6.10.4.2.1

These provisions are intended to apply to the design live load specified in Article 3.6.1.1. If this criterion were to be applied to a design permit load, a reduction in the load factor for live load should be considered.

Article 6.10.1.7 requires that one percent longitudinal deck reinforcement be placed wherever the tensile stress in the concrete deck due to either factored construction loads or due to Load Combination Service II exceeds the factored modulus of rupture of the concrete. By controlling the crack size in regions where adequate shear connection is also provided, the concrete deck may be considered effective in tension for computing flexural stresses on the composite section due to Load Combination Service II.

The cracking behavior and the partial participation of the physically cracked slab in transferring forces in tension is very complex. Article 6.10.4.2.1 provides specific guidance that the concrete slab may be assumed to be uncracked when the maximum longitudinal concrete tensile stress is smaller than $2f_r$. This limit between the use of an uncracked or cracked section for calculation of flexural stresses in the structural steel is similar to a limit suggested in CEN (2004) beyond which the effects of concrete cracking should be considered.

C6.10.4.2.2

Eqs. 6.10.4.2.2-1 through 6.10.4.2.2-3 are intended to prevent objectionable permanent deflections due to expected severe traffic loadings that would impair rideability. For homogeneous sections with zero flange lateral bending, they correspond to the overload check in the 2002 AASHTO Standard Specifications and are based on successful past practice. Their development is described in Vincent (1969). A resistance factor is not applied in

$$f_f + \frac{f_\ell}{2} \leq 0.95R_h F_{yf} \quad (6.10.4.2.2-2)$$

- For both steel flanges of noncomposite sections:

$$f_f + \frac{f_\ell}{2} \leq 0.80R_h F_{yf} \quad (6.10.4.2.2-3)$$

where:

- f_f = flange stress at the section under consideration due to the Service II loads calculated without consideration of flange lateral bending (ksi)
- f_ℓ = flange lateral bending stress at the section under consideration due to the Service II loads determined as specified in Article 6.10.1.6 (ksi)
- R_h = hybrid factor determined as specified in Article 6.10.1.10.1

For continuous span flexural members in straight I-girder bridges that satisfy the requirements of Article B6.2, a calculated percentage of the negative moment due to the Service II loads at the pier section under consideration may be redistributed using the procedures of either Article B6.3 or B6.6.

For compact composite sections in positive flexure utilized in shored construction, the longitudinal compressive stress in the concrete deck due to the Service II loads, determined as specified in Article 6.10.1.1.1d, shall not exceed $0.6f'_c$.

Except for composite sections in positive flexure in which the web satisfies the requirement of Article 6.10.2.1.1, all sections shall also satisfy the following requirement:

$$f_c \leq F_{crw} \quad (6.10.4.2.2-4)$$

where:

- f_c = compression-flange stress at the section under consideration due to the Service II loads calculated without consideration of flange lateral bending (ksi)
- F_{crw} = nominal bend-buckling resistance for webs with or without longitudinal stiffeners, as applicable, determined as specified in Article 6.10.1.9 (ksi)

these equations because the specified limits are serviceability criteria for which the resistance factor is 1.0.

Eqs. 6.10.4.2.2-1 through 6.10.4.2.2-3 address the increase in flange stresses caused by early web yielding in hybrid sections by including the hybrid factor R_h .

For continuous-span members in which noncomposite sections are utilized in negative flexure regions only, it is recommended that Eqs. 6.10.4.2.2-1 and 6.10.4.2.2-2, as applicable, be applied in those regions.

Under the load combinations specified in Table 3.4.1-1, Eqs. 6.10.4.2.2-1 through 6.10.4.2.2-3, as applicable, do not control and need not be checked for the following sections:

- Composite sections in negative flexure for which the nominal flexural resistance under the Strength load combinations is determined according to the provisions of Article 6.10.8;
- Noncomposite sections with $f_\ell = 0$ and for which the nominal flexural resistance under the Strength load combinations is determined according to the provisions of Article 6.10.8;
- Noncompact composite sections in positive flexure.

However, Eq. 6.10.4.2.2-4 must still be checked for these sections where applicable.

The 1/2 factor in Eqs. 6.10.4.2.2-2 and 6.10.4.2.2-3 comes from Schilling (1996) and Yoo and Davidson (1997). Eqs. 6.10.4.2.2-2 and 6.10.4.2.2-3 with a limit of F_{yf} on the right-hand side are a close approximation to rigorous yield interaction equations for the load level corresponding to the onset of yielding at the web-flange juncture, including the effect of flange tip yielding that occurs prior to this stage, but not considering flange residual stress effects. If the flanges are nominally elastic at the web-flange juncture and the elastically computed flange lateral bending stresses are limited as required by Eq. 6.10.1.6-1, the permanent deflections will be small. The $0.95R_h$ and $0.80R_h$ factors are included on the right hand side of Eqs. 6.10.4.2.2-2 and 6.10.4.2.2-3 to make them compatible with the corresponding equations in the prior Specifications when $f_\ell = 0$, and to provide some additional conservatism for control of permanent deformations when the flange lateral bending is significant. The sign of f_f and f_ℓ should always be taken as positive in Eqs. 6.10.4.2.2-2 and 6.10.4.2.2-3.

f_ℓ is not included in Eq. 6.10.4.2.2-1 because the top flange is continuously braced by the concrete deck. For continuously braced top flanges of noncomposite sections, the f_ℓ term in Eq. 6.10.4.2.2-3 may be taken equal to zero.

Lateral bending in the bottom flange is only a consideration at the service limit state for all horizontally curved I-girder bridges and for straight I-girder bridges with discontinuous cross-frame or diaphragm lines in conjunction with skews exceeding 20 degrees. Wind load and deck overhang effects are not considered at the service limit state.

Localized yielding in negative-flexural sections at interior piers results in redistribution of the elastic moments. For continuous-span flexural members in straight I-girder bridges that satisfy the provisions of Article B6.2, the procedures of either Article B6.3 or B6.6 may be used to calculate the redistribution moments at the service limit state. These procedures represent an improvement on the former ten-percent redistribution rule. When the redistribution moments are calculated according to these procedures, Eqs. 6.10.4.2.2-1 through 6.10.4.2.2-3, as applicable, need not be checked within the regions extending from the pier section under consideration to the nearest flange transition or point of permanent-load contraflexure, whichever is closest, in each adjacent span. Eq. 6.10.4.2.2-4 must still be considered within these regions using the elastic moments prior to redistribution. At all locations outside of these regions, Eqs. 6.10.4.2.2-1 through 6.10.4.2.2-4, as applicable, must be satisfied after redistribution. Research has not yet been conducted to extend the provisions of Appendix B6 to kinked (chorded) continuous or horizontally curved steel I-girder bridges.

For compact composite sections utilized in shored construction, the longitudinal stresses in the concrete deck are limited to $0.6f'_c$ to ensure linear behavior of the concrete. In unshored construction, the concrete stress near first yielding of either steel flange is generally significantly less than f'_c thereby eliminating the need to check the concrete stress in this case.

With the exception of composite sections in positive flexure in which the web satisfies the requirement of Article 6.10.2.1.1 such that longitudinal stiffeners are not required, and web bend-buckling effects are negligible, web bend-buckling of all sections must be checked under the Service II Load Combination according to Eq. 6.10.4.2.2-4. Article C6.10.1.9.1 explains why web bend-buckling does not need to be checked for the above exception. Options to consider should the web bend-buckling resistance be exceeded are similar to those discussed for the construction condition at the end of Article C6.10.3.2.1, except of course for adjusting the deck-placement sequence.

If the concrete deck is assumed effective in tension in regions of negative flexure, as permitted at the service limit state for composite sections satisfying the requirements specified in Article 6.10.4.2.1, more than half of the web may be in compression thus increasing the susceptibility to web bend-buckling. As specified in Article D6.3.1, for composite sections in negative flexure, the appropriate value of D_c to be used at the service limit state depends on whether or not the concrete deck is assumed effective in tension. For noncomposite sections, D_c of the steel section alone should always be used.

6.10.5—Fatigue and Fracture Limit State

6.10.5.1—Fatigue

Details shall be investigated for fatigue as specified in Article 6.6.1. The applicable Fatigue load combination specified in Table 3.4.1-1 and the fatigue live load specified in Article 3.6.1.4 shall apply.

For horizontally curved I-girder bridges, the fatigue stress range due to major-axis bending plus lateral bending shall be investigated.

The provisions for fatigue in shear connectors specified in Articles 6.10.10.2 and 6.10.10.3 shall apply.

6.10.5.2—Fracture

Fracture toughness requirements specified in the contract documents shall be in conformance with the provisions of Article 6.6.2.

6.10.5.3—Special Fatigue Requirement for Webs

For the purposes of this Article, the factored fatigue load shall be determined using the Fatigue I load combination specified in Table 3.4.1-1, with the fatigue live load taken as specified in Article 3.6.1.4.

Interior panels of webs with transverse stiffeners, with or without longitudinal stiffeners, shall satisfy the following requirement:

$$V_u \leq V_{cr} \quad (6.10.5.3-1)$$

where:

V_u = shear in the web at the section under consideration due to the unfactored permanent load plus the factored fatigue load (kip)

V_{cr} = shear-buckling resistance determined from Eq. 6.10.9.3.3-1 (kip)

C6.10.5.1

In horizontally curved I-girder bridges, the base metal adjacent to butt welds and welded attachments on discretely braced flanges subject to a net applied tensile stress must be checked for the fatigue stress range due to major-axis bending, plus flange lateral bending, at the critical transverse location on the flange. Examples of welded attachments for which this requirement applies include transverse stiffeners and gusset plates receiving lateral bracing members. The base metal adjacent to flange-to-web welds need only be checked for the stress range due to major-axis bending since the welds are located near the center of the flange. Flange lateral bending need not be considered for details attached to continuously braced flanges.

C6.10.5.3

If Eq. 6.10.5.3-1 is satisfied, significant elastic flexing of the web due to shear is not expected to occur, and the member is assumed able to sustain an infinite number of smaller loadings without fatigue cracking due to this effect.

This provision is included here, rather than in Article 6.6, because it involves a check of the maximum web shear-buckling stress instead of a check of the stress ranges caused by cyclic loading.

The live load stress due to the passage of the specified fatigue live load for this check is that of the heaviest truck expected to cross the bridge in 75 years.

The check for bend-buckling of webs given in AASHTO (2004) due to the load combination specified in this Article is not included in these Specifications. For all sections, except for composite sections in positive flexure in which the web satisfies Article 6.10.2.1.1, a web bend-buckling check is required under the Service II Load Combination according to the provisions of Article 6.10.4.2.2. As discussed further in Article C6.10.1.9.1, web bend-buckling of composite sections in positive flexure is not a concern at any limit state after the section is in its final composite condition for sections with webs that satisfy Article 6.10.2.1.1. For all other sections, the web bend-buckling check under the Service II loads will control over a similar check under the load combination specified in this Article. For composite sections in positive flexure with webs that do not satisfy Article 6.10.2.1.1, the smaller value of F_{crw} resulting from the larger value of D_c at the fatigue limit state tends to be

compensated for by the lower web compressive stress due to the load combination specified in this Article. Web bend-buckling of these sections is also checked under the construction condition according to Eq. 6.10.3.2.1-3.

The shear in unstiffened webs is already limited to either the shear-yielding or shear-buckling resistance at the strength limit state according to the provisions of Article 6.10.9.2. The shear in end panels of stiffened webs is also limited to the shear-yielding or shear-buckling resistance at the strength limit state according to the provisions of Article 6.10.9.3.3. Consequently, the requirement in this Article need not be checked for unstiffened webs or the end panels of stiffened webs.

6.10.6—Strength Limit State

6.10.6.1—General

For the purposes of this Article, the applicable Strength load combinations specified in Table 3.4.1-1 shall apply.

C6.10.6.1

At the strength limit state, Article 6.10.6 directs the Engineer to the appropriate Articles for the design of composite or noncomposite I-sections in regions of positive or negative flexure.

For sections in which the flexural resistance is expressed in terms of stress, the elastically computed flange stress is strictly not an estimate of the actual flange stress because of limited partial yielding within the cross-section due to the combination of applied load effects with initial residual stresses and various other incidental stress contributions not included within the design analysis calculations. The effects of partial yielding within the cross-section on the distribution of internal forces within the system prior to reaching the maximum resistances as defined in these Specifications are minor and may be neglected in the calculation of the applied stresses and/or moments.

The use of stresses is considered to be more appropriate in members within which the maximum resistance is always less than or equal to the yield moment M_y in major-axis bending. This is due to the nature of the different types of loadings that contribute to the member flexural stresses: noncomposite, long-term composite and short-term composite. The combined effects of the loadings on these different states of the member cross-section are better handled by working with flange stresses rather than moments. Also, if the Engineer uses analysis software in which the webs of I-section members and/or the composite deck are represented as plate elements, the flange stresses are obtained directly from the software, whereas the total bending moment supported by a given member requires further processing. Finally, bridge engineers typically are more accustomed to working with stresses rather than moments. Therefore, although the provisions can be written equivalently in terms of bending moment, the provisions of Article 6.10 are written in terms of stress whenever the maximum potential resistance in terms of f_{bu} is less than or equal to F_y .

Conversely, for members in which the resistance is potentially greater than M_y , significant yielding within the cross-section makes the handling of the capacities in terms of stress awkward. Although the provisions that are written in terms of moment can be written equivalently in terms of elastic stress quantities, the corresponding elastic stress limits will be generally greater than the yield stress since the moments are greater than the yield moment. Also, the calculation of the resistance where it is generally greater than M_y is fundamentally based on stress resultants. For example, M_p for a compact composite section in positive flexure is based on a plastic analysis of the composite cross-section. Therefore, it is more natural to write the resistance equations in terms of bending moments for these types of sections. This is also the practice in AASHTO (2004).

For sections in which the flexural resistance is expressed in terms of moment, the moments acting on the noncomposite, long-term composite and short-term composite sections may be directly summed for comparison to the nominal flexural resistance. That is, the effect of the sequence of application of the different types of loads on the stress states and of partial yielding within the cross-section on the maximum resistance need not be considered.

In subsequent Articles, a continuously braced flange in compression is assumed not to be subject to local or lateral torsional buckling. The rationale for excluding these limit state checks is discussed in Article C6.10.3.2.3.

These provisions assume low or zero levels of axial force in the member. At sections that are also subject to a concentrically-applied axial force, P_u , due to the factored loads in excess of ten percent of the factored axial resistance of the member, P_r , at the strength limit state, the section should instead be checked according to the provisions of Article 6.8.2.3 or 6.9.2.2, as applicable. According to the equations given in these Articles, when P_u is ten percent of P_r , the flexural resistance of the member is reduced by five percent. Below this level, it is reasonable to ignore the effect of the axial force in the design of the member.

6.10.6.2—Flexure

6.10.6.2.1—General

If there are holes in the tension flange at the section under consideration, the tension flange shall satisfy the requirement specified in Article 6.10.1.8.

C6.10.6.2.1

The requirement of Article 6.10.1.8 is intended to prevent net section fracture at a cross-section with holes in the tension flange subject to either positive or negative flexure.

6.10.6.2.2—Composite Sections in Positive Flexure

Composite sections in kinked (chorded) continuous or horizontally curved steel girder bridges shall be considered as noncompact sections and shall satisfy the requirements of Article 6.10.7.2.

C6.10.6.2.2

The nominal flexural resistance of composite sections in positive flexure in straight bridges satisfying specific steel grade, web slenderness and ductility requirements is permitted to exceed the moment at first yield according to

Composite sections in straight bridges that satisfy the following requirements shall qualify as compact composite sections:

- The specified minimum yield strengths of the flanges do not exceed 70.0 ksi,
- The web satisfies the requirement of Article 6.10.2.1.1, and
- The section satisfies the web slenderness limit:

$$\frac{2D_{cp}}{t_w} \leq 3.76 \sqrt{\frac{E}{F_{yc}}} \quad (6.10.6.2.2-1)$$

where:

D_{cp} = depth of the web in compression at the plastic moment determined as specified in Article D6.3.2 (in.)

Compact sections shall satisfy the requirements of Article 6.10.7.1. Otherwise, the section shall be considered noncompact and shall satisfy the requirements of Article 6.10.7.2.

Compact and noncompact sections shall satisfy the ductility requirement specified in Article 6.10.7.3.

the provisions of Article 6.10.7. The nominal flexural resistance of these sections, termed compact sections, is therefore more appropriately expressed in terms of moment. For composite sections in positive flexure in straight bridges not satisfying one or more of these requirements, or for composite sections in positive flexure in horizontally curved bridges, termed noncompact sections, the nominal flexural resistance is not permitted to exceed the moment at first yield. The nominal flexural resistance in these cases is therefore more appropriately expressed in terms of the elastically computed flange stress.

Composite sections in positive flexure in straight bridges with flange yield strengths greater than 70.0 ksi or with webs that do not satisfy Article 6.10.2.1.1 are to be designed at the strength limit state as noncompact sections as specified in Article 6.10.7.2. For concrete compressive strengths typically employed for deck construction, the use of larger steel yield strengths may result in significant nonlinearity and potential crushing of the deck concrete prior to reaching the flexural resistance specified for compact sections in Article 6.10.7.1. Longitudinal stiffeners generally must be provided in sections with webs that do not satisfy Article 6.10.2.1.1. Since composite longitudinally-stiffened sections tend to be deeper and used in longer spans with corresponding larger noncomposite dead load stresses, they tend to have D_c/t_w values that would preclude the development of substantial inelastic flexural strains within the web prior to bend-buckling at moment levels close to $R_h M_y$. Therefore, although the depth of the web in compression typically reduces as plastic strains associated with moments larger than $R_h M_y$ are incurred, and D_{cp} may indeed satisfy Eq. 6.10.6.2.2-1 at the plastic moment resistance, sufficient test data do not exist to support the design of these types of sections for M_p . Furthermore, because of the relative size of the steel section to the concrete deck typical for these types of sections, M_p often is not substantially larger than $R_h M_y$. Due to these factors, composite sections in positive flexure in which the web does not satisfy Article 6.10.2.1.1 are categorized as noncompact sections. Composite sections in positive flexure in kinked (chorded) continuous or horizontally curved steel bridges are also to be designed at the strength limit state as noncompact sections as specified in Article 6.10.7.2. Research has not yet been conducted to support the design of these sections for a nominal flexural resistance exceeding the moment at first yield.

The web slenderness requirement of this Article is adopted from AISC (2005) and gives approximately the same allowable web slenderness as specified for compact sections in AASHTO (2002). Most composite sections in positive flexure without longitudinal web stiffeners will qualify as compact according to this criterion since the concrete deck causes an upward shift in the neutral axis, which reduces the depth of the web in compression. Also, D/t_w for these sections is limited to a maximum value of 150 based on the requirement of Article 6.10.2.1.1. The

6.10.6.2.3—Composite Sections in Negative Flexure and Noncomposite Sections

Sections in all kinked (chorded) continuous or horizontally curved steel girder bridges shall be proportioned according to the provisions specified in Article 6.10.8.

Sections in straight bridges whose supports are normal or skewed not more than 20° from normal, and with intermediate diaphragms or cross-frames placed in contiguous lines parallel to the supports, for which:

- The specified minimum yield strengths of the flanges do not exceed 70.0 ksi,
- The web satisfies the noncompact slenderness limit:

$$\frac{2D_c}{t_w} < 5.7 \sqrt{\frac{E}{F_{yc}}} \quad (6.10.6.2.3-1)$$

and:

- The flanges satisfy the following ratio:

$$\frac{I_{yc}}{I_{yt}} \geq 0.3 \quad (6.10.6.2.3-2)$$

where:

- D_c = depth of the web in compression in the elastic range (in.). For composite sections, D_c shall be determined as specified in Article D6.3.1.
- I_{yc} = moment of inertia of the compression flange of the steel section about the vertical axis in the plane of the web (in.⁴)
- I_{yt} = moment of inertia of the tension flange of the steel section about the vertical axis in the plane of the web (in.⁴)

location of the neutral axis of the composite section at the plastic moment may be determined using the equations listed in Table D6.1-1.

Compact composite sections in positive flexure must also satisfy the provisions of Article 6.10.7.3 to ensure a ductile mode of failure. Noncompact sections must also satisfy the ductility requirement specified in Article 6.10.7.3 to ensure a ductile failure. Satisfaction of this requirement ensures an adequate margin of safety against premature crushing of the concrete deck for sections utilizing up to 100-ksi steels and/or for sections utilized in shored construction. This requirement is also a key limit in allowing web bend-buckling to be disregarded in the design of composite sections in positive flexure when the web also satisfies Article 6.10.2.1.1, as discussed in Article C6.10.1.9.1.

C6.10.6.2.3

For composite sections in negative flexure and noncomposite sections, the provisions of Article 6.10.8 limit the nominal flexural resistance to be less than or equal to the moment at first yield. As a result, the nominal flexural resistance for these sections is conveniently expressed in terms of the elastically computed flange stress.

For composite sections in negative flexure or noncomposite sections in straight bridges without skewed supports or with limited skews that satisfy the specified steel grade requirements and with webs that satisfy Eq. 6.10.6.2.3-1 and flanges that satisfy Eq. 6.10.6.2.3-2, the optional provisions of Appendix A6 may be applied to determine the nominal flexural resistance, which may exceed the moment at first yield. Therefore, the nominal flexural resistance determined from the provisions of Appendix A6 is expressed in terms of moment. Because these types of sections are less commonly used, the provisions for their design have been placed in an appendix in order to simplify and streamline the main design provisions. The provisions of Article 6.10.8 may be used for these types of sections to obtain an accurate to somewhat conservative determination of the nominal flexural resistance than would be obtained using Appendix A6.

For composite sections in negative flexure or noncomposite sections in straight bridges not satisfying one or more of these requirements, or for these sections in horizontally curved bridges, the provisions of Article 6.10.8 must be used. Research has not yet been conducted to extend the provisions of Appendix A6 either to sections in kinked (chorded) continuous or horizontally curved steel bridges or to bridges with supports skewed more than 20 degrees from normal. Severely skewed bridges with contiguous cross-frames have significant transverse stiffness and thus already have large cross-frame forces in the elastic range. As interior-pier sections yield and begin to lose stiffness and shed their load, the forces in the adjacent cross-frames will increase. There is currently no established procedure to predict the resulting increase in the forces without

may be proportioned according to the provisions for compact or noncompact web sections specified in Appendix A6. Otherwise, the section shall be proportioned according to provisions specified in Article 6.10.8.

For continuous span flexural members in straight bridges that satisfy the requirements of Article B6.2, a calculated percentage of the negative moments due to the factored loads at the pier section under consideration may be redistributed using the procedures of either Article B6.4 or B6.6.

performing a refined nonlinear analysis. With discontinuous cross-frames, significant lateral flange bending effects can occur. The resulting lateral bending moments and stresses are amplified in the bottom compression flange adjacent to the pier as the flange deflects laterally. There is currently no means to accurately predict these amplification effects as the flange is also yielding. Skewed supports also result in twisting of the girders, which is not recognized in plastic-design theory. The relative vertical deflections of the girders create eccentricities that are also not recognized in the theory. Thus, until further research is done to examine these effects in greater detail, a conservative approach has been taken in the specification.

Eq. 6.10.6.2.3-1 defines the slenderness limit for a noncompact web. A web with a slenderness ratio exceeding this limit is termed slender. The previous Specifications defined sections as compact or noncompact and did not explicitly distinguish between a noncompact and a slender web. For noncompact webs, theoretical web bend-buckling does not occur for elastic stress values, computed according to beam theory, smaller than the limit of the flexural resistance. Sections with slender webs rely upon the significant web post bend-buckling resistance under Strength Load Combinations. Specific values for the noncompact web slenderness limit for different grades of steel are listed in Table C6.10.1.10.2-2.

A compact web is one that satisfies the slenderness limit given by Eq. A6.2.1-1. Sections with compact webs and $I_{yc}/I_{yt} \geq 0.3$ are able to develop their full plastic moment capacity M_p provided that other steel grade, ductility, flange slenderness and/or lateral bracing requirements are satisfied. The web-slenderness limit given by Eq. A6.2.1-1 is significantly smaller than the limit shown in Table C6.10.1.10.2-2. It is generally satisfied by rolled I-shapes, but typically not by the most efficient built-up section proportions.

The flange yield stress, F_{yc} , is more relevant to the web buckling behavior and its influence on the flexural resistance than F_{yw} . For a section that has a web proportioned at the noncompact limit, a stable nominally elastic compression flange tends to constrain a lower-strength hybrid web at stress levels less than or equal to $R_h F_{yc}$. For a section that has a compact web, the inelastic strains associated with development of the plastic flexural resistance are more closely related to the flange rather than the web yield strength.

The majority of steel-bridge I-sections utilize either slender webs or noncompact webs that approach the slenderness limit of Eq. 6.10.6.2.3-1 represented by the values listed in Table C6.10.1.10.2-2. For these sections, the simpler and more streamlined provisions of Article 6.10.8 are the most appropriate for determining the nominal flexural resistance of composite sections in negative flexure and noncomposite sections. These provisions may also be applied to sections with compact webs or to sections with noncompact webs that are nearly compact, but at the

expense of some economy. Such sections are typically used in bridges with shorter spans. The potential loss in economy increases with decreasing web slenderness. The Engineer should give strong consideration to utilizing the provisions of Appendix A6 to compute the nominal flexural resistance of these sections in straight bridges, in particular, sections with compact webs.

Eq. 6.10.6.2.3-2 is specified to guard against extremely monosymmetric noncomposite I-sections, in which analytical studies indicate a significant loss in the influence of the St. Venant torsional rigidity GJ on the lateral-torsional buckling resistance due to cross-section distortion. The influence of web distortion on the lateral torsional buckling resistance is larger for such members. If the flanges are of equal thickness, this limit is equivalent to $b_{fc} \geq 0.67b_{fi}$.

Yielding in negative-flexural sections at interior piers at the strength limit state results in redistribution of the elastic moments. For continuous-span flexural members in straight bridges that satisfy the provisions of Article B6.2, the procedures of either Article B6.4 or B6.6 may be used to calculate redistribution moments at the strength limit state. These provisions replace the former ten-percent redistribution allowance and provide a more rational approach for calculating the percentage redistribution from interior-pier sections. When the redistribution moments are calculated according to these procedures, the flexural resistances at the strength limit state within the unbraced lengths immediately adjacent to interior-pier sections satisfying the requirements of Article B6.2 need not be checked. At all other locations, the provisions of Articles 6.10.7, 6.10.8.1 or A6.1, as applicable, must be satisfied after redistribution. The provisions of Article B6.2 are often satisfied by compact-flange unstiffened or transversely-stiffened pier sections that are otherwise designed by Article 6.10.8 or Appendix A6 using $C_b = 1.0$. Research has not yet been conducted to extend the provisions of Appendix B6 to kinked (chorded) continuous or horizontally curved steel bridges.

6.10.6.3—Shear

The provisions of Article 6.10.9 shall apply.

6.10.6.4—Shear Connectors

The provisions of Article 6.10.10.4 shall apply.

6.10.7—Flexural Resistance—Composite Sections in Positive Flexure

6.10.7.1—Compact Sections

6.10.7.1.1—General

At the strength limit state, the section shall satisfy:

$$M_u + \frac{1}{3} f_c S_{xt} \leq \phi_f M_n \quad (6.10.7.1.1-1)$$

C6.10.7.1.1

For composite sections in positive flexure, lateral bending does not need to be considered in the compression flange at the strength limit state because the flange is continuously supported by the concrete deck.

where:

- ϕ_f = resistance factor for flexure specified in Article 6.5.4.2
- f_ℓ = flange lateral bending stress determined as specified in Article 6.10.1.6 (ksi)
- M_n = nominal flexural resistance of the section determined as specified in Article 6.10.7.1.2 (kip-in.)
- M_u = bending moment about the major-axis of the cross-section determined as specified in Article 6.10.1.6 (kip-in.)
- M_{yt} = yield moment with respect to the tension flange determined as specified in Article D6.2 (kip-in.)
- S_{xt} = elastic section modulus about the major axis of the section to the tension flange taken as M_{yt}/F_{yt} (in.³)

6.10.7.1.2—Nominal Flexural Resistance

The nominal flexural resistance of the section shall be taken as:

If $D_p \leq 0.1 D_t$, then:

$$M_n = M_p \tag{6.10.7.1.2-1}$$

Otherwise:

$$M_n = M_p \left(1.07 - 0.7 \frac{D_p}{D_t} \right) \tag{6.10.7.1.2-2}$$

where:

- D_p = distance from the top of the concrete deck to the neutral axis of the composite section at the plastic moment (in.)
- D_t = total depth of the composite section (in.)
- M_p = plastic moment of the composite section determined as specified in Article D6.1 (kip-in.)

In a continuous span, the nominal flexural resistance of the section shall satisfy:

Eq. 6.10.7.1.1-1 is an interaction equation that addresses the influence of lateral bending within the tension flange, represented by the elastically computed flange lateral bending stress, f_ℓ , combined with the major-axis bending moment, M_u . This equation is similar to the subsequent Eqs. 6.10.7.2.1-2 and 6.10.8.1.2-1, the basis of which is explained in Article C6.10.8.1.2. However, these other equations are expressed in an elastically computed stress format, and the resistance term on their right-hand side is generally equal to $\phi_f R_n F_{yt}$. Eq. 6.10.7.1.1-1 is expressed in a bending moment format, but alternatively can be considered in a stress format by dividing both sides of the equation by the elastic section modulus, S_{xt} .

The term M_n on the right-hand side of Eq. 6.10.7.1.1-1 is generally greater than the yield moment capacity, M_{yt} . Therefore, the corresponding resistance, written in the format of an elastically computed stress, is generally greater than F_{yt} . These Specifications use a moment format for all resistance equations which, if written in terms of an elastically computed stress, can potentially assume resistance values greater than the specified minimum yield strength of the steel. In these types of sections, the major-axis bending moment is physically a more meaningful quantity than the corresponding elastically computed bending stress.

Eq. 6.10.7.1.1-1 gives a reasonably accurate but conservative representation of the results from an elastic-plastic section analysis in which a fraction of the width from the tips of the tension flange is deducted to accommodate flange lateral bending. The rationale for calculation of S_{xt} , as defined in this Article for use in Eq. 6.10.7.1.1-1, is discussed in Article CA6.1.1.

C6.10.7.1.2

Eq. 6.10.7.1.2-2 implements the philosophy introduced by Wittry (1993) that an additional margin of safety should be applied to the theoretical nominal flexural resistance of compact composite sections in positive flexure when the depth of the plastic neutral axis below the top of the deck, D_p , exceeds a certain value. This additional margin of safety, which increases approximately as a linear function of D_p/D_t , is intended to protect the concrete deck from premature crushing, thereby ensuring adequate ductility of the composite section. Sections with D_p/D_t less than or equal to 0.1 can reach as a minimum the plastic moment, M_p , of the composite section without any ductility concerns.

Eq. 6.10.7.1.2-2 gives approximately the same results as the comparable equation in previous Specifications, but is a simpler form that depends only on the plastic moment resistance M_p and on the ratio D_p/D_t , as also suggested in Yakel and Azizinamini (2005). Both equations implement the above philosophy justified by Wittry (1993). Eq. 6.10.7.1.2-2 is somewhat more restrictive than the equation in previous Specifications for sections with small values of M_p/M_y , such as sections with hybrid webs, a relatively small deck area and a high-strength tension flange. It is somewhat less restrictive for sections with large values

$$M_n \leq 1.3 R_h M_y \quad (6.10.7.1.2-3)$$

where:

M_n = nominal flexural resistance determined from Eq. 6.10.7.1.2-1 or 6.10.7.1.2-2, as applicable (kip-in.)

M_y = yield moment determined as specified in Article D6.2 (kip-in.)

R_h = hybrid factor determined as specified in Article 6.10.1.10.1

unless:

- the span under consideration and all adjacent interior-pier sections satisfy the requirements of Article B6.2,

and:

- the appropriate value of θ_{RL} from Article B6.6.2 exceeds 0.009 radians at all adjacent interior-pier sections,
- in which case the nominal flexural resistance of the section is not subject to the limitation of Eq. 6.10.7.1.2-3.

of M_p/M_y . Wittry (1993) considered various experimental test results and performed a large number of parametric cross-section analyses. The smallest experimental or theoretical resistance of all the cross-sections considered in this research and in other subsequent studies is $0.96M_p$. Eq. 6.10.7.1.2-2 is based on the target additional margin of safety of 1.28 specified by Wittry at the maximum allowed value of D_p combined with an assumed theoretical resistance of $0.96M_p$ at this limit. At the maximum allowed value of D_p specified by Eq. 6.10.7.3-1, the resulting nominal design flexural resistance is $0.78M_p$.

The limit of $D_p < 0.1D_t$ for the use of Eq. 6.10.7.1.2-1 is obtained by use of a single implicit β value of 0.75 in the comparable equations from AASHTO (2004). AASHTO (2004) specifies $\beta = 0.7$ for $F_y = 50$ and 70.0 ksi and $\beta = 0.9$ for $F_y = 36.0$ ksi. The value of $\beta = 0.75$ is justifiable for all cases based on the scatter in strain-hardening data. The derived β values are sensitive to the assumed strain-hardening characteristics.

The shape factor, M_p/M_y , for composite sections in positive flexure can be somewhat larger than 1.5 in certain cases. Therefore, a considerable amount of yielding and resulting inelastic curvature is required to reach M_p in these situations. This yielding reduces the effective stiffness of the positive flexural section. In continuous spans, the reduction in stiffness can shift moment from the positive to the negative flexural regions. If the interior-pier sections in these regions do not have additional capacity to sustain these larger moments and are not designed to have ductile moment-rotation characteristics according to the provisions of Appendix B6, the shedding of moment to these sections could result in incremental collapse under repeated live load applications. Therefore, for cases where the span or either of the adjacent interior-pier sections do not satisfy the provisions of Article B6.2, or where the appropriate value of θ_{RL} from Article B6.6.2 at either adjacent pier section is less than or equal to 0.009 radians, the positive flexural sections must satisfy Eq. 6.10.7.1.2-3.

It is possible to satisfy the above concerns by ensuring that the pier section flexural resistances are not exceeded if the positive flexural section moments above $R_h M_y$ are redistributed and combined with the concurrent negative moments at the pier sections determined from an elastic analysis. This approach is termed the Refined Method in AASHTO (2004). However, concurrent moments are not typically tracked in the analysis and so this method is not included in these Specifications.

Eq. 6.10.7.1.2-3 is provided to limit the amount of additional moment allowed above $R_h M_y$ at composite sections in positive flexure to 30 percent of $R_h M_y$ in continuous spans where the span or either of the adjacent pier sections do not satisfy the requirements of Article B6.2. The $1.3R_h M_y$ limit is the same as the limit specified for the Approximate Method in AASHTO (2004). The nominal flexural resistance determined from Eq. 6.10.7.1.2-3 is not to exceed the resistance determined from either Eq. 6.10.7.1.2-1 or 6.10.7.1.2-2, as applicable,

to ensure adequate strength and ductility of the composite section. In cases where D_p/D_i is relatively large and M_p/M_y is relatively small, Eq. 6.10.7.1.2-2 may govern relative to Eq. 6.10.7.1.2-3. However, for most practical cases, Eq. 6.10.7.1.2-3 will control.

Interior-pier sections satisfying the requirements of Article B6.2 and for which the appropriate value of θ_{RL} from Article B6.6.2 exceeds 0.009 radians have sufficient ductility and robustness such that the redistribution of moments caused by partial yielding within the positive flexural regions is inconsequential. The value of 0.009 radians is taken as an upper bound for the potential increase in the inelastic rotations at the interior-pier sections due to positive-moment yielding. Thus, the nominal flexural resistance of positive flexural sections in continuous spans that meet these requirements is not limited due to the effect of potential moment shifting. These restrictions are often satisfied by compact-flange unstiffened or transversely-stiffened pier sections designed by Article 6.10.8 or Appendix A6 using $C_b = 1.0$. All current ASTM A6 rolled I-shapes satisfying Eqs. B6.2.1-3, B6.2.2-1, and B6.2.4-1 meet these restrictions. All built-up sections satisfying Article B6.2 that also either have $D/b_{fc} < 3.14$ or satisfy the additional requirements of Article B6.5.1 meet these restrictions.

The Engineer is not required to redistribute moments from the pier sections in order to utilize the additional resistance in positive flexure, but only to satisfy the stated restrictions from Appendix B6 that ensure significant ductility and robustness of the adjacent pier sections. Redistribution of the pier moments is permitted in these cases, if desired, according to the provisions of Appendix B6.

Assuming the fatigue and fracture limit state does not control, under the load combinations specified in Table 3.4.1-1 and in the absence of flange lateral bending, the permanent deflection service limit state criterion given by Eq. 6.10.4.2.2-2 will often govern the design of the bottom flange of compact composite sections in positive flexure wherever the nominal flexural resistance at the strength limit state is based on either Eq. 6.10.7.1.2-1, 6.10.7.1.2-2, or 6.10.7.1.2-3. Thus, it is prudent and expedient to initially design these types of sections to satisfy this permanent deflection service limit state criterion and then to subsequently check the nominal flexural resistance at the strength limit state according to the applicable Eq. 6.10.7.1.2-1, 6.10.7.1.2-2, or 6.10.7.1.2-3.

6.10.7.2—Noncompact Sections

6.10.7.2.1—General

At the strength limit state, the compression flange shall satisfy:

$$f_{bu} \leq \phi_f F_{nc} \quad (6.10.7.2.1-1)$$

where:

C6.10.7.2.1

For noncompact sections, the compression flange must satisfy Eq. 6.10.7.2.1-1 and the tension flange must satisfy Eq. 6.10.7.2.1-2 at the strength limit state. The basis for Eq. 6.10.7.2.1-2 is explained in Article C6.10.8.1.2. For composite sections in positive flexure, lateral bending does not need to be considered in the compression flange at the strength limit state because the flange is continuously

- ϕ_f = resistance factor for flexure specified in Article 6.5.4.2
- f_{bu} = flange stress calculated without consideration of flange lateral bending determined as specified in Article 6.10.1.6 (ksi)
- F_{nc} = nominal flexural resistance of the compression flange determined as specified in Article 6.10.7.2.2 (ksi)

The tension flange shall satisfy:

$$f_{bu} + \frac{1}{3}f_c \leq \phi_f F_{nt} \quad (6.10.7.2.1-2)$$

where:

- f_ℓ = flange lateral bending stress determined as specified in Article 6.10.1.6 (ksi)
- F_{nt} = nominal flexural resistance of the tension flange determined as specified in Article 6.10.7.2.2 (ksi)

The maximum longitudinal compressive stress in the concrete deck at the strength limit state, determined as specified in Article 6.10.1.1.1d, shall not exceed $0.6f'_c$.

6.10.7.2.2—Nominal Flexural Resistance

The nominal flexural resistance of the compression flange shall be taken as:

$$F_{nc} = R_b R_h F_{yc} \quad (6.10.7.2.2-1)$$

where:

- R_b = web load-shedding factor determined as specified in Article 6.10.1.10.2
- R_h = hybrid factor determined as specified in Article 6.10.1.10.1

The nominal flexural resistance of the tension flange shall be taken as:

$$F_{nt} = R_h F_{yt} \quad (6.10.7.2.2-2)$$

6.10.7.3—Ductility Requirement

Compact and noncompact sections shall satisfy:

$$D_p \leq 0.42 D_t \quad (6.10.7.3-1)$$

where:

- D_p = distance from the top of the concrete deck to the neutral axis of the composite section at the plastic moment (in.)
- D_t = total depth of the composite section (in.)

supported by the concrete deck.

For noncompact sections, the longitudinal stress in the concrete deck is limited to $0.6f'_c$ to ensure linear behavior of the concrete, which is assumed in the calculation of the steel flange stresses. This condition is unlikely to govern except in cases involving: (1) shored construction, or unshored construction where the noncomposite steel dead load stresses are low, combined with (2) geometries causing the neutral axis of the short-term and long-term composite section to be significantly below the bottom of the concrete deck.

C6.10.7.2.2

The nominal flexural resistance of noncompact composite sections in positive flexure is limited to the moment at first yield. Thus, the nominal flexural resistance is expressed simply in terms of the flange stress. For noncompact sections, the elastically computed stress in each flange due to the factored loads, determined in accordance with Article 6.10.1.1.1a, is compared with the yield stress of the flange times the appropriate flange-strength reduction factors.

C6.10.7.3

The ductility requirement specified in this Article is intended to protect the concrete deck from premature crushing. The limit of $D_p < 5D'$ in AASHTO (2004) corresponds to $D_p/D_t < 0.5$ for $\beta = 0.75$. The D_p/D_t ratio is lowered to 0.42 in Eq. 6.10.7.3-1 to ensure significant yielding of the bottom flange when the crushing strain is reached at the top of concrete deck for all potential cases. In checking this requirement, D_t should be computed using a lower bound estimate of the actual thickness of the concrete haunch, or may be determined conservatively by neglecting the thickness of the haunch.

6.10.8—Flexural Resistance—Composite Sections in Negative Flexure and Noncomposite Sections

6.10.8.1—General

6.10.8.1.1—Discretely Braced Flanges in Compression

C6.10.8.1.1

At the strength limit state, the following requirement shall be satisfied:

$$f_{bu} + \frac{1}{3}f_{\ell} \leq \phi_f F_{nc} \quad (6.10.8.1.1-1)$$

where:

- ϕ_f = resistance factor for flexure specified in Article 6.5.4.2
- f_{bu} = flange stress calculated without consideration of flange lateral bending determined as specified in Article 6.10.1.6 (ksi)
- f_{ℓ} = flange lateral bending stress determined as specified in Article 6.10.1.6 (ksi)
- F_{nc} = nominal flexural resistance of the flange determined as specified in Article 6.10.8.2 (ksi)

Eq. 6.10.8.1.1-1 addresses the resistance of the compression flange by considering this element as an equivalent beam-column. This equation is effectively a beam-column interaction equation, expressed in terms of the flange stresses computed from elastic analysis (White and Grubb, 2004). The f_{bu} term is analogous to the axial load and the f_{ℓ} term is analogous to the bending moment within the equivalent beam-column member. The factor of one-third in front of the f_{ℓ} term in Eq. 6.10.8.1.1-1 gives an accurate linear approximation of the equivalent beam-column resistance within the limits on f_{ℓ} specified in Article 6.10.1.6 (White and Grubb, 2005).

Eqs. 6.10.8.1.1-1, 6.10.8.1.2-1, and 6.10.8.1.3-1 are developed specifically for checking of slender-web noncomposite sections and slender-web composite sections in negative flexure. These equations may be used as a simple conservative resistance check for other types of composite sections in negative flexure and noncomposite sections. The provisions specified in Appendix A6 may be used for composite sections in negative flexure and for noncomposite sections with compact or noncompact webs in straight bridges for which the specified minimum yield strengths of the flanges and web do not exceed 70 ksi and for which the flanges satisfy Eq. 6.10.6.2.3-2. The Engineer should give consideration to utilizing the provisions of Appendix A6 for such sections in straight bridges with compact webs; however, Appendix A6 provides only minor increases in the nominal resistance for sections in which the web slenderness approaches the noncompact web limit of Eq. 6.10.6.2.3-1.

6.10.8.1.2—Discretely Braced Flanges in Tension

C6.10.8.1.2

At the strength limit state, the following requirement shall be satisfied:

$$f_{bu} + \frac{1}{3}f_{\ell} \leq \phi_f F_{nt} \quad (6.10.8.1.2-1)$$

where:

- F_{nt} = nominal flexural resistance of the flange determined as specified in Article 6.10.8.3 (ksi)

6.10.8.1.3—Continuously Braced Flanges in Tension or Compression

At the strength limit state, the following requirement shall be satisfied:

$$f_{bu} \leq \phi_f R_h F_{yf} \quad (6.10.8.1.3-1)$$

Eq. 6.10.8.1.2-1 is an accurate approximation of the full plastic strength of a rectangular flange cross-section subjected to combined vertical and lateral bending within the limit of Eq. 6.10.1.6-1, originally proposed by Hall and Yoo (1996).

6.10.8.2 Compression-Flange Flexural Resistance

6.10.8.2.1—General

Eq. 6.10.8.1.1-1 shall be satisfied for both local buckling and lateral torsional buckling using the appropriate value of F_{nc} determined for each case as specified in Articles 6.10.8.2.2 and 6.10.8.2.3, respectively.

C6.10.8.2.1

All of the I-section compression-flange flexural resistance equations of these Specifications are based consistently on the logic of identifying the two anchor points shown in Figure C6.10.8.2.1-1 for the case of uniform major-axis bending. Anchor point 1 is located at the length $L_b = L_p$ for lateral-torsional buckling (LTB) or flange slenderness $b_{fc}/2t_{fc} = \lambda_{pf}$ for flange local buckling (FLB) corresponding to development of the maximum potential flexural resistance, labeled as F_{max} or M_{max} in the figure, as applicable. Anchor point 2 is located at the length L_r or flange slenderness λ_{rf} for which the inelastic and elastic LTB or FLB resistances are the same. In Article 6.10.8, this resistance is taken as $R_b F_{yr}$, where F_{yr} is taken as the smaller of $0.7F_{yc}$ and F_{yw} , but not less than $0.5F_{yc}$. With the exception of hybrid sections with F_{yw} significantly smaller than F_{yc} , $F_{yr} = 0.7F_{yc}$. This limit corresponds to a nominal compression flange residual stress effect of $0.3F_{yc}$. The $0.5F_{yc}$ limit on F_{yr} avoids anomalous situations for some types of cross-sections in which the inelastic buckling equation gives a larger resistance than the corresponding elastic buckling curve. Also, the $0.5F_{yc}$ limit is equivalent to the implicit value of F_{yr} used in AASHTO (2004). For $L_b > L_r$ or $b_{fc}/2t_{fc} > \lambda_{rf}$, the LTB and FLB resistances are governed by elastic buckling. However, the elastic FLB resistance equations are not specified explicitly in these provisions since the limits of Article 6.10.2.2 preclude elastic FLB for specified minimum yield strengths up to and including $F_{yc} = 90$ ksi. Use of the inelastic FLB Eq. 6.10.8.2.2-2 is permitted for rare cases in which $b_{fc}/2t_{fc}$ can potentially exceed λ_{rf} for $F_{yc} > 90$ ksi.

For unbraced lengths subjected to moment gradient, the LTB resistances for the case of uniform major-axis bending are simply scaled by the moment gradient modifier C_b , with the exception that the LTB resistance is capped at F_{max} or M_{max} , as illustrated by the dashed line in Figure C6.10.8.2.1-1. The maximum unbraced length at which the LTB resistance is equal to F_{max} or M_{max} under a moment gradient may be determined from Article D6.4.1 or D6.4.2, as applicable. The FLB resistance for moment gradient cases is the same as that for the case of uniform major-axis bending, neglecting the relatively minor influence of moment gradient effects.

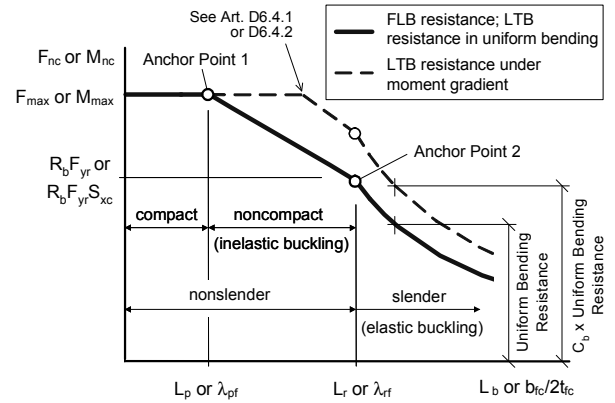

Figure C6.10.8.2.1-1—Basic Form of All I-section Compression-Flange Flexural Resistance Equations

6.10.8.2.2—Local Buckling Resistance

The local buckling resistance of the compression flange shall be taken as:

- If $\lambda_f \leq \lambda_{pf}$, then:

$$F_{nc} = R_b R_h F_{yc} \quad (6.10.8.2.2-1)$$

- Otherwise:

$$F_{nc} = \left[1 - \left(1 - \frac{F_{yr}}{R_h F_{yc}} \right) \left(\frac{\lambda_f - \lambda_{pf}}{\lambda_{rf} - \lambda_{pf}} \right) \right] R_b R_h F_{yc} \quad (6.10.8.2.2-2)$$

in which:

λ_f = slenderness ratio for the compression flange

$$= \frac{b_{fc}}{2t_{fc}} \quad (6.10.8.2.2-3)$$

$$\lambda_{pf} = 0.38 \sqrt{\frac{E}{F_{yc}}} \quad (6.10.8.2.2-4)$$

λ_{rf} = limiting slenderness ratio for a noncompact flange

$$= 0.56 \sqrt{\frac{E}{F_{yr}}} \quad (6.10.8.2.2-5)$$

where:

C6.10.8.2.2

Eq. 6.10.8.2.2-4 defines the slenderness limit for a compact flange whereas Eq. 6.10.8.2.2-5 gives the slenderness limit for a noncompact flange. The nominal flexural resistance of a section with a compact flange is independent of the flange slenderness, whereas the flexural resistance of a section with a noncompact flange is expressed as a linear function of the flange slenderness as illustrated in Figure C6.10.8.2.1-1. The compact flange slenderness limit is the same as specified in AISC (2005) and in AASHTO (1996, 2004). For different grades of steel, this slenderness limit is as follows:

Table C6.10.8.2.2-1—Limiting Slenderness Ratio for a Compact Flange

F_{yc} (ksi)	λ_{pf}
36.0	10.8
50.0	9.2
70.0	7.7
90.0	6.8
100.0	6.5

Eq. 6.10.8.2.2-5 is based conservatively on the more general limit given by Eq. A6.3.2-5, but with a flange local buckling coefficient of $k_c = 0.35$. With the exception of hybrid sections with $F_{yw} < 0.7F_{yc}$, the term F_{yr} in Eq. 6.10.8.2.2-5 is always equal to $0.7F_{yc}$.

- F_{yr} = compression-flange stress at the onset of nominal yielding within the cross-section, including residual stress effects, but not including compression-flange lateral bending, taken as the smaller of $0.7F_{yc}$ and F_{yw} , but not less than $0.5F_{yc}$
- R_b = web load-shedding factor determined as specified in Article 6.10.1.10.2
- R_h = hybrid factor determined as specified in Article 6.10.1.10.1

6.10.8.2.3—Lateral Torsional Buckling Resistance

For unbraced lengths in which the member is prismatic, the lateral torsional buckling resistance of the compression flange shall be taken as:

- If $L_b \leq L_p$, then:

$$F_{nc} = R_b R_h F_{yc} \quad (6.10.8.2.3-1)$$

- If $L_p < L_b \leq L_r$, then:

$$F_{nc} = C_b \left[1 - \left(1 - \frac{F_{yr}}{R_h F_{yc}} \right) \left(\frac{L_b - L_p}{L_r - L_p} \right) \right] R_b R_h F_{yc} \leq R_b R_h F_{yc} \quad (6.10.8.2.3-2)$$

- If $L_b > L_r$, then:

$$F_{nc} = F_{cr} \leq R_b R_h F_{yc} \quad (6.10.8.2.3-3)$$

in which:

- L_b = unbraced length (in.)
- L_p = limiting unbraced length to achieve the nominal flexural resistance of $R_b R_h F_{yc}$ under uniform bending (in.)

$$= 1.0 r_t \sqrt{\frac{E}{F_{yc}}} \quad (6.10.8.2.3-4)$$

- L_r = limiting unbraced length to achieve the onset of nominal yielding in either flange under uniform bending with consideration of compression-flange residual stress effects (in.)

$$= \pi r_t \sqrt{\frac{E}{F_{yr}}} \quad (6.10.8.2.3-5)$$

- C_b = moment gradient modifier. In lieu of an alternative rational analysis, C_b may be calculated as follows:

C6.10.8.2.3

Eq. 6.10.8.2.3-4 defines the compact unbraced length limit for a member subjected to uniform major-axis bending, whereas Eq. 6.10.8.2.3-5 gives the corresponding noncompact unbraced length limit. The nominal flexural resistance of a member braced at or below the compact limit is independent of the unbraced length, whereas the flexural resistance of a member braced at or below the noncompact limit is expressed as a linear function of the unbraced length as illustrated in Figure C6.10.8.2.1-1. The compact bracing limit of Eq. 6.10.8.2.3-4 is similar to the bracing requirement for use of the general compact-section flexural resistance equations and/or the Q formula equations in AASHTO (2004) for $F_{yc} = 50$ ksi. For larger F_{yc} values, it is somewhat less restrictive than the previous requirement. The limit given by Eq. 6.10.8.2.3-4 is generally somewhat more restrictive than the limit given by the corresponding L_p equation in AASHTO (2004) and AISC (2005). The limit given by Eq. 6.10.8.2.3-4 is based on linear regression analysis within the region corresponding to the inelastic lateral torsional buckling equation, shown qualitatively in Figure C6.10.8.2.1-1, for a wide range of data from experimental flexural tests involving uniform major-axis bending and in which the physical effective length for lateral torsional buckling is effectively 1.0.

Note that the most economical solution is not necessarily achieved by limiting the unbraced length to L_p in order to reach the maximum flexural resistance, F_{max} , particularly if the moment gradient modifier, C_b , is taken equal to 1.0.

Eq. 6.10.8.2.3-8 is a conservative simplification of Eq. A6.3.3-8, which gives the exact beam-theory based solution for the elastic lateral torsional buckling resistance of a doubly-symmetric I-section (Timoshenko and Gere, 1961) for the case of uniform major-axis bending when C_b is equal to 1.0 and when r_t is defined as:

$$r_t = \frac{b_{fc}}{\sqrt{12 \left(\frac{h}{d} + \frac{1}{3} \frac{D_c t_w}{b_{fc} t_{fc}} \frac{D^2}{hd} \right)}} \quad (C6.10.8.2.3-1)$$

- For unbraced cantilevers and for members where $f_{mid}/f_2 > 1$ or $f_2 = 0$

$$C_b = 1.0 \quad (6.10.8.2.3-6)$$

- For all other cases:

$$C_b = 1.75 - 1.05 \left(\frac{f_1}{f_2} \right) + 0.3 \left(\frac{f_1}{f_2} \right)^2 \leq 2.3 \quad (6.10.8.2.3-7)$$

F_{cr} = elastic lateral torsional buckling stress (ksi)

$$= \frac{C_b R_b \pi^2 E}{\left(\frac{L_b}{r_t} \right)^2} \quad (6.10.8.2.3-8)$$

r_t = effective radius of gyration for lateral torsional buckling (in.)

$$= \frac{b_{fc}}{\sqrt{12 \left(1 + \frac{1}{3} \frac{D_c t_w}{b_{fc} t_{fc}} \right)}} \quad (6.10.8.2.3-9)$$

where:

F_{yr} = compression-flange stress at the onset of nominal yielding within the cross-section, including residual stress effects, but not including compression-flange lateral bending, taken as the smaller of $0.7F_{yc}$ and F_{yws} , but not less than $0.5F_{yc}$

D_c = depth of the web in compression in the elastic range (in.). For composite sections, D_c shall be determined as specified in Article D6.3.1.

f_{mid} = stress without consideration of lateral bending at the middle of the unbraced length of the flange under consideration, calculated from the moment envelope value that produces the largest compression at this point, or the smallest tension if this point is never in compression (ksi). f_{mid} shall be due to the factored loads and shall be taken as positive in compression and negative in tension.

f_0 = stress without consideration of lateral bending at the brace point opposite to the one corresponding to f_2 , calculated from the moment envelope value that produces the largest compression at this point in the flange under consideration, or the smallest tension if this point is never in compression (ksi). f_0 shall be due to the factored loads and shall be taken as positive in compression and negative in tension.

f_1 = stress without consideration of lateral bending at the brace point opposite to the one corresponding to f_2 , calculated as the intercept of the most critical assumed linear stress variation passing

Eq. 6.10.8.2.3-8 provides an accurate to conservative estimate of the compression flange elastic lateral torsional buckling resistance, including the effect of the distortional flexibility of the web (White, 2004). Eq. 6.10.8.2.3-9 is a simplification of the above r_t equation obtained by assuming $D = h = d$. For sections with thick flanges, Eq. 6.10.8.2.3-9 gives an r_t value that can be as much as three to four percent conservative relative to the exact equation. Use of Eq. C6.10.8.2.3-1 is permitted for software calculations or if the Engineer requires a more precise calculation of the elastic LTB resistance. The other key simplification in Eq. 6.10.8.2.3-8 is that the St. Venant torsional constant J is assumed equal to zero. This simplification is prudent for cases such as longitudinally-stiffened girders with web slenderness values approaching the maximum limit of Eq. 6.10.2.1.2-1. For these types of sections, the contribution of J to the elastic lateral torsional buckling resistance is generally small and is likely to be reduced due to distortion of the web into an S shape and the corresponding raking of the compression flange relative to the tension flange. However, for sections that have web slenderness values approaching the noncompact limit given by Eq. 6.10.6.2.3-1 and listed for different yield strengths in Table C6.10.1.10.2-2, the assumption of $J = 0$ is convenient but tends to be conservative. For typical flexural I-sections with $D/b_{fc} > 2$ and $I_{yc}/I_{yt} \geq 0.3$, the effect of this assumption on the magnitude of the noncompact bracing limit L_r is usually smaller than ten percent (White, 2001).

Eqs. 6.10.8.2.3-8 and A6.3.3-8 provide one single consistent representation of the elastic LTB resistance for all types of I-section members. These equations give a conservative representation of the elastic LTB resistance of composite I-section members in negative flexure since they neglect the restraint provided to the bottom compression flange by the lateral and torsional stiffness of the deck. The effects of this restraint are reduced in general by web distortion. The benefits of this restraint are judged to not be worth the additional complexity associated with a general distortional buckling solution, particularly if it is suspected that less than effectively fixed torsional restraint is provided to a relatively large bridge I-girder by the deck.

The Engineer should note the importance of the web term $D_c t_w$ within Eq. 6.10.8.2.3-9. Prior Specifications have often used the radius of gyration of only the compression flange, $r_{yc} = b_{fc} / \sqrt{12}$, within the design equations for LTB. This approximation can lead to significant unconservative predictions relative to experimental and refined finite-element results. The web term in Eq. 6.10.8.2.3-9 accounts for the destabilizing effects of the flexural compression within the web.

If $D_c t_w / b_{fc} t_{fc}$ in Eq. 6.10.8.2.3-9 is taken as a representative value of 2.0, this equation reduces to $0.22b_{fc}$. Based on this assumption and $F_{yc} = 50$ ksi, the compact bracing limit is $L_p = 5.4b_{fc}$ and the noncompact bracing limit given by Eq. 6.10.8.2.3-5 simplifies to $L_r = 20b_{fc}$. Based on these same assumptions, the equations of Articles B6.2.4 and D6.4 give corresponding limits on L_b that are generally larger

through f_2 and either f_{mid} or f_0 , whichever produces the smaller value of C_b (ksi). f_1 may be determined as follows:

- When the variation in the moment along the entire length between the brace points is concave in shape:

$$f_1 = f_0 \quad (6.10.8.2.3-10)$$

- Otherwise:

$$f_1 = 2f_{mid} - f_2 \geq f_0 \quad (6.10.8.2.3-11)$$

f_2 = except as noted below, largest compressive stress without consideration of lateral bending at either end of the unbraced length of the flange under consideration, calculated from the critical moment envelope value (ksi). f_2 shall be due to the factored loads and shall be taken as positive. If the stress is zero or tensile in the flange under consideration at both ends of the unbraced length, f_2 shall be taken as zero.

R_b = web load-shedding factor determined as specified in Article 6.10.1.10.2

R_h = hybrid factor determined as specified in Article 6.10.1.10.1

For unbraced lengths where the member consists of noncomposite monosymmetric sections and is subject to reverse curvature bending, the lateral torsional buckling resistance shall be checked for both flanges, unless the top flange is considered to be continuously braced.

For unbraced lengths in which the member is nonprismatic, the lateral torsional buckling resistance of the compression flange F_{nc} at each section within the unbraced length may be taken as the smallest resistance within the unbraced length under consideration determined from Eq. 6.10.8.2.3-1, 6.10.8.2.3-2, or 6.10.8.2.3-3, as applicable, assuming the unbraced length is prismatic. The moment gradient modifier, C_b , shall be taken equal to 1.0 in this case and L_b shall not be modified by an effective length factor.

For unbraced lengths containing a transition to a smaller section at a distance less than or equal to 20 percent of the unbraced length from the brace point with the smaller moment, the lateral torsional buckling resistance may be determined assuming the transition to the smaller section does not exist provided the lateral moment of inertia of the flange or flanges of the smaller section is equal to or larger than one-half the corresponding value in the larger section.

than $5.4 b_{fc}$. The limit given in Article B6.2.4 is sufficient to permit moment redistribution at interior-pier sections of continuous-span members. The limit given in Article D6.4 is sufficient to develop F_{max} or M_{max} shown in Figure C6.10.8.2.1-1 in cases involving a moment gradient along the unbraced length for which $C_b > 1.0$.

The effect of the variation in the moment along the length between brace points is accounted for by the moment gradient modifier, C_b . C_b has a base value of 1.0 when the moment and the corresponding flange compressive major-axis bending stress are constant over the unbraced length. C_b may be conservatively taken equal to 1.0 for all cases, with the exception of some unusual circumstances involving no cross-bracing within the span or cantilever beams with significant top-flange loading as discussed below.

The procedure for calculation of C_b retains Eq. 6.10.8.2.3-7 from the previous Specifications; however, the definition of when C_b is to be taken equal to 1.0 and the specific calculation of the terms f_1 and f_2 in Eq. 6.10.8.2.3-7 have been modified to remove ambiguities and to address a number of potentially important cases where the prior C_b calculations are significantly unconservative relative to more refined solutions. One specific example is a simply-supported member supporting its own weight as well as a uniform transverse load, but braced only at its ends and its mid-span. This ideal case is representative of potential erection conditions in which the number of cross-frames within the superstructure is minimal and the superstructure is being considered in its noncomposite condition prior to hardening of a cast-in-place concrete slab. For this case, the prior Specifications give a C_b value of 1.75 whereas the more accurate equations from AISC (1999) give a C_b value of 1.30. The smaller C_b value of 1.30 is due to the parabolic shape of the moment diagram, and the fact that the flange compression is significantly larger within the unbraced lengths than the linear variation implicitly assumed in the prior application of Eq. 6.10.8.2.3-7.

The procedure for calculation of C_b in these provisions addresses the above issues by utilizing the stress due to the factored loads at the middle of the unbraced length of the flange under consideration, f_{mid} . If f_{mid} is greater than or equal to the largest compressive stress in the flange due to the factored loads at either end of the unbraced length, f_2 , C_b is taken equal to 1.0. Also, in rare situations where the flange stress is zero or tensile at both ends of its unbraced length, for which f_2 is defined as zero, C_b is taken equal to 1.0. This type of situation occurs only for members with very large unbraced lengths such as simply-supported or continuous spans with no cross-bracing within the span. For unbraced cantilevers, C_b is also taken equal to 1.0, consistent with AASHTO (2004) and AISC (2005).

For all other cases, significant beneficial and calculable moment gradient effects exist. In these cases, Eq. 6.10.8.2.3-7 requires the approximation of the stress variation along the unbraced length as the most critical of:

(1) a line that passes through f_2 and f_{mid} or (2) a line that passes between f_2 and the calculated stress in the flange under consideration at the opposite end of the unbraced length, f_0 , whichever produces the smaller value of C_b . The intercept of this most critical assumed linear stress variation at the opposite end from f_2 is denoted as f_1 . For the specific example cited above, this procedure gives a C_b value of 1.30, which is identical to the C_b value predicted by the more refined AISC (2005) equation. In all cases where f_{mid} is smaller in magnitude than the average of f_0 and f_2 , or when the moment diagram or envelope along the entire length between brace points is concave in shape, f_1 and f_2 in Eq. 6.10.8.2.3-7 are always equal to the stresses at the ends of the unbraced length in the flange under consideration; that is, $f_1 = f_0$. Sample illustrations of the calculation of the C_b factor for various cases are provided at the end of Appendix C6.

For unbraced lengths where the member consists of monosymmetric noncomposite I-sections and is subject to reverse curvature bending, the lateral torsional buckling resistance must be checked in general for both flanges, unless the top flange is considered to be continuously braced. Since the flanges are of different sizes in these types of sections, the lateral torsional buckling resistance may be governed by compression in the smaller flange, even though this compressive stress may be smaller than the maximum compression in the larger flange. The specified approach generally produces accurate to conservative values of C_b for these cases. For highly monosymmetric sections and reverse curvature bending, the values of C_b between 1.75 and 2.3 obtained using these provisions are often significantly conservative relative to refined calculations of the lateral torsional buckling resistance, such as those provided by Kitipornchai and Trahair (1986). However, these provisions are less conservative than the resistances estimated by a refinement of the AISC (2005) C_b equation given by Helwig et al. (1997) when the transverse loading effects are small and the variation of the moment along the unbraced length is approximately linear. For other cases involving significant transverse loading effects, the refined AISC equation recommended by Helwig et al. (1997) gives more accurate and less conservative results for unbraced lengths where the member is subjected to reverse curvature bending. The top flange of composite I-sections in unbraced lengths where the member is subject to reverse curvature bending need not be checked for lateral torsional buckling since the flange is continuously braced.

Strict application of the C_b provisions would require the consideration of the concurrent moments along the unbraced length. This would necessitate the calculation of: (1) the maximum possible value of f_2 at the brace point with the higher compressive stress using the critical moment envelope value, along with calculation of f_{mid} and f_0 using the concurrent moments, and (2) the maximum possible compressive value of f_{mid} using the critical moment envelope value, along with the calculation of f_0

and f_2 using the concurrent moments. However, since concurrent moments are normally not tracked in the analysis, it is convenient and always conservative to use the worst-case moment values to compute the above stresses. The worst-case moment for calculation of f_2 is the critical envelope value, or the moment causing the largest value of f_2 in the flange under consideration. The worst-case moments used to compute f_0 and f_{mid} are the values obtained from the moment envelopes that produce the largest compressive stress, or the smallest tensile stress if the point is never in compression, within the flange under consideration at each of these locations. The use of the worst-case moments to compute f_2 , f_{mid} and f_0 is always conservative since it can be shown that a more critical stress distribution along the unbraced length can never exist for all possible concurrent loadings. This includes any potential condition in which the stress is smaller at the f_2 or f_{mid} locations, but in which the moment gradient is also smaller thus producing a smaller value of C_b . Furthermore, the use of the concurrent moments to compute f_0 and f_{mid} for the loading that gives the largest value of f_2 always would result in a larger value of C_b for this specific loading. Similarly, the use of the concurrent moments to compute f_2 and f_0 for the loading that produces the largest compressive value of f_{mid} always would result in a larger value of C_b for this specific loading.

The preceding guidelines are also applicable when calculating C_b for compact and noncompact web sections designed by Article A6.3.3. The use of the compression-flange major-axis bending stresses for calculating C_b is strongly recommended for sections designed by Article 6.10.8 since this practice better reflects the fact that the dead and live load bending moments due to the factored loads are applied to different sections in composite girders. However, for convenience, the ratio of the major-axis bending moments at the brace points may be used in lieu of the ratio of the compression-flange stresses if it is felt in the judgment of the Engineer that the use of these alternative ratios does not have a significant effect on the final calculated value of C_b . For compact and noncompact web sections designed by Article A6.3.3, it is specified that the major-axis bending moments be used when computing C_b . Moments are used in Eq. A6.3.3-7 because the overall effect of applying the moments to the different sections is less critical for these types of sections.

Where C_b is greater than 1.0, indicating the presence of a significant beneficial moment gradient effect, the lateral torsional buckling resistances may alternatively be calculated by the equivalent procedures specified in Article D6.4.1. Both the equations in this Article and in Article D6.4.1 permit F_{max} in Figure C6.10.8.2.1-1 to be reached at larger unbraced lengths when C_b is greater than 1.0. The procedures in Article D6.4.1 allow the Engineer to focus directly on the maximum unbraced length at which the flexural resistance is equal to F_{max} . The use of these equivalent procedures is strongly recommended when C_b values greater than 1.0 are utilized in the design.

Although the calculation of C_b greater than 1.0 in general can result in a dependency of the flexural resistance on the applied loading, and hence subsequent difficulties in load rating, a C_b value only slightly greater than 1.0 is sufficient in most cases to develop the maximum flexural resistance F_{max} . As long as the combination of the brace spacing and $C_b > 1.0$ is sufficient to develop F_{max} , the flexural resistance is independent of the applied loading. Therefore, when $C_b > 1.0$ is used, it is recommended that the unbraced lengths, L_b , at critical locations be selected such that this condition is satisfied in the final constructed condition. The provisions in this Article tend to give values of C_b that are accurate to significantly conservative. Therefore, if the above guidelines are followed in design, it is unlikely that the flexural resistance would differ from F_{max} in any rating situation, particularly if the Engineer was to use a more refined calculation of C_b for the rating calculations. Other more refined formulations for C_b may be found in Galambos (1998).

The C_b equations in these provisions and in AISC (2005) both neglect the effect of the location of the applied load relative to the mid-height of the section. For unusual situations with no intermediate cross-bracing and for unbraced cantilevers with significant loading applied at the level of the top flange, the Engineer should consider including load-height effects within the calculation of C_b . In these cases, the associated C_b values can be less than 1.0. Galambos (1998) gives equations for consideration of load-height effects in simple or continuous spans, and Dowswell (2002) gives solutions considering these effects in unbraced cantilevers. When $C_b < 1.0$, F_n can be smaller than F_{max} in Figure C6.10.8.2.1-1 even when L_b is less than or equal to L_p . Therefore, for $C_b < 1.0$, the resistance should be calculated from Eq. 6.10.8.2.3-2 for L_b less than or equal to L_r .

For rehabilitation design or in extraordinary circumstances, the Engineer may consider modifying L_b by an elastic effective length factor for lateral torsional buckling. Galambos (1998) and Nethercot and Trahair (1976) present a simple hand method that may be used for this calculation.

Galambos (1998) provides general guidelines for stability design of bracing systems. In past practice, points of contraflexure sometimes have been considered as brace points when the influence of moment gradient was not included in the lateral-torsional buckling resistance equations. In certain cases, this practice can lead to a substantially unconservative estimate of the flexural resistance. These Specifications do not intend for points of contraflexure to be considered as brace points. The influence of moment gradient may be accounted for correctly through the use of C_b and the effect of restraint from adjacent unbraced segments may be accounted for by using an effective length factor less than 1.0.

For the case of uniform bending, the reduction in the elastic lateral-torsional buckling resistance due to a transition to a smaller section is approximately five percent when the transition is placed at 20 percent of the unbraced length from one of the brace points and the lateral moment of inertia of the flange in the smaller section is set at one-half of the corresponding value in the larger section (Carskaddan and Schilling, 1974). For moment gradient cases in which the larger bending moment occurs within the larger section, and/or where the section transition is placed closer to the brace point, and/or where the lateral moment of inertia of the flange of the smaller section is larger than one-half of the corresponding value in the larger section, the reduction in the lateral-torsional buckling resistance is less than five percent. Since section transitions are typically placed within regions having a significant moment gradient, the effect of the section transition on the lateral-torsional buckling resistance may be neglected whenever the stated conditions are satisfied. For a case with more than one transition, any transition located within 20 percent of the unbraced length from the brace point with the smaller moment may be ignored and the lateral torsional buckling resistance of the remaining nonprismatic unbraced length may then be computed as the smallest resistance based on the remaining sections.

For unbraced lengths containing a transition to a smaller section at a distance greater than 20 percent of the unbraced length from the brace point with the smaller moment, the lateral torsional buckling resistance should be taken as the smallest resistance, F_{nc} , within the unbraced length under consideration. This approximation is based on replacing the nonprismatic member with an equivalent prismatic member. The cross-section of the equivalent member that gives the correct lateral torsional buckling resistance is generally some weighted average of all the cross-sections along the unbraced length. If the cross-section within the unbraced length that gives the smallest uniform bending resistance is used, and the calculated resistance is not exceeded at any section along the unbraced length, a conservative solution is obtained. A suggested procedure to provide a more refined estimate of the lateral torsional buckling resistance for this case is presented in Grubb and Schmidt (2004).

To avoid a significant reduction in the lateral torsional buckling resistance, flange transitions can be located within 20 percent of the unbraced length from the brace point with the smaller moment, given that the lateral moment of inertia of the flange or flanges of the smaller section is equal to or larger than one-half of the corresponding value in the larger section.

6.10.8.3—Tension-Flange Flexural Resistance

The nominal flexural resistance of the tension flange shall be taken as:

$$F_{nt} = R_h F_{yt} \quad (6.10.8.3-1)$$

where:

R_h = hybrid factor determined as specified in Article 6.10.1.10.1

6.10.9—Shear Resistance

6.10.9.1—General

At the strength limit state, straight and curved web panels shall satisfy:

$$V_u \leq \phi_v V_n \quad (6.10.9.1-1)$$

where:

ϕ_v = resistance factor for shear specified in Article 6.5.4.2

V_n = nominal shear resistance determined as specified in Articles 6.10.9.2 and 6.10.9.3 for unstiffened and stiffened webs, respectively (kip)

V_u = shear in the web at the section under consideration due to the factored loads (kip)

Transverse intermediate stiffeners shall be designed as specified in Article 6.10.11.1. Longitudinal stiffeners shall be designed as specified in Article 6.10.11.3.

Interior web panels of nonhybrid and hybrid I-shaped members:

- Without a longitudinal stiffener and with a transverse stiffener spacing not exceeding $3D$, or
- With one or more longitudinal stiffeners and with a transverse stiffener spacing not exceeding $1.5D$

shall be considered stiffened, and the provisions of Article 6.10.9.3 shall apply. Otherwise, the panel shall be considered unstiffened, and the provisions of Article 6.10.9.2 shall apply.

For stiffened webs, provisions for end panels shall be as specified in Article 6.10.9.3.3.

C6.10.9.1

This Article applies to:

- Sections without stiffeners,
- Sections with transverse stiffeners only, and
- Sections with both transverse and longitudinal stiffeners.

A flowchart for determining the shear resistance of I-sections is shown below.

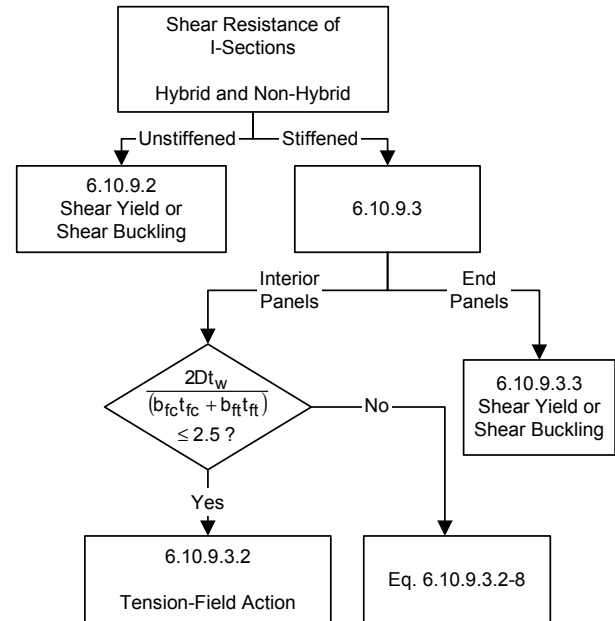

Figure C6.10.9.1-1—Flowchart for Shear Design of I-Sections

Unstiffened and stiffened interior web panels are defined according to the maximum transverse stiffener spacing requirements specified in this Article.

The nominal shear resistance of unstiffened web panels in both nonhybrid and hybrid members is defined by either shear yielding or shear buckling, depending on the web slenderness ratio, as specified in Article 6.10.9.2.

The nominal shear resistance of stiffened interior web panels of both nonhybrid and hybrid members, where the section along the entire panel is proportioned to satisfy Eq. 6.10.9.3.2-1, is defined by the sum of the shear-yielding or shear-buckling resistance and the postbuckling resistance from tension-field action, as specified in Article 6.10.9.3.2. Otherwise, the shear resistance is taken

6.10.9.2—Nominal Resistance of Unstiffened Webs

The nominal shear resistance of unstiffened webs shall be taken as:

$$V_n = V_{cr} = CV_p \quad (6.10.9.2-1)$$

in which:

$$V_p = 0.58 F_{yw} D t_w \quad (6.10.9.2-2)$$

where:

- C = ratio of the shear-buckling resistance to the shear yield strength determined by Eqs. 6.10.9.3.2-4, 6.10.9.3.2-5 or 6.10.9.3.2-6 as applicable, with the shear-buckling coefficient, k , taken equal to 5.0
- V_{cr} = shear-buckling resistance (kip)
- V_n = nominal shear resistance (kip)
- V_p = plastic shear force (kip)

6.10.9.3—Nominal Resistance of Stiffened Webs

6.10.9.3.1—General

The nominal shear resistance of transversely or transversely and longitudinally-stiffened interior web panels shall be as specified in Articles 6.10.9.3.2. The nominal shear resistance of transversely or transversely and longitudinally-stiffened end web panels shall be as specified in Articles 6.10.9.3.3. The total web depth, D , shall be used in determining the nominal shear resistance of web panels with longitudinal stiffeners. The required transverse stiffener spacing shall be calculated using the maximum shear in a panel.

Stiffeners shall satisfy the requirements specified in Article 6.10.11.

as the shear resistance given by Eq. 6.10.9.3.2-8. Previous Specifications did not recognize the potential for web panels of hybrid members to develop postbuckling resistance due to tension-field action. The applicability of these provisions to the shear strength of curved nonhybrid and hybrid webs is addressed by Zureick et al. (2002), White et al. (2001), White and Barker (2004), White et al. (2004), and Jung and White (2006).

For nonhybrid and hybrid members, the nominal shear resistance of end panels in stiffened webs is defined by either shear yielding or shear buckling, as specified in Article 6.10.9.3.3.

C6.10.9.2

The consideration of tension-field action (Basler, 1961) is not permitted for unstiffened web panels. The elastic shear-yielding or shear-buckling resistance is calculated as the product of the constant C specified in Article 6.10.9.3.2 times the plastic shear force, V_p , given by Eq. 6.10.9.2-2. The plastic shear force is equal to the web area times the assumed shear yield strength of $F_{yw}/\sqrt{3}$. The shear-buckling coefficient, k , to be used in calculating the constant C is defined as 5.0 for unstiffened web panels, which is a conservative approximation of the exact value of 5.35 for an infinitely long strip with simply-supported edges (Timoshenko and Gere, 1961).

C6.10.9.3.1

Longitudinal stiffeners divide a web panel into subpanels. In Cooper (1967), the shear resistance of the entire panel is taken as the sum of the shear resistance of the subpanels. However, the contribution to the shear resistance of a single longitudinal stiffener located at its optimum position for flexure is relatively small. Thus, it is conservatively specified that the influence of the longitudinal stiffener be neglected in computing the nominal shear resistance of the web plate.

6.10.9.3.2—Interior Panels

The nominal shear resistance of an interior web panel complying with the provisions of Article 6.10.9.1, and with the section along the entire panel proportioned such that:

$$\frac{2Dt_w}{(b_{fc}t_{fc} + b_{ft}t_{ft})} \leq 2.5 \quad (6.10.9.3.2-1)$$

shall be taken as:

$$V_n = V_p \left[C + \frac{0.87(1-C)}{\sqrt{1 + \left(\frac{d_o}{D}\right)^2}} \right] \quad (6.10.9.3.2-2)$$

in which:

$$V_p = 0.58F_{yw}Dt_w \quad (6.10.9.3.2-3)$$

where:

- d_o = transverse stiffener spacing (in.)
- V_n = nominal shear resistance of the web panel (kip)
- V_p = plastic shear force (kip)
- C = ratio of the shear-buckling resistance to the shear yield strength

The ratio, C , shall be determined as specified below:

- If $\frac{D}{t_w} \leq 1.12\sqrt{\frac{Ek}{F_{yw}}}$, then:

$$C = 1.0 \quad (6.10.9.3.2-4)$$

- If $1.12\sqrt{\frac{Ek}{F_{yw}}} < \frac{D}{t_w} \leq 1.40\sqrt{\frac{Ek}{F_{yw}}}$, then:

$$C = \frac{1.12}{\frac{D}{t_w}} \sqrt{\frac{Ek}{F_{yw}}} \quad (6.10.9.3.2-5)$$

- If $\frac{D}{t_w} > 1.40\sqrt{\frac{Ek}{F_{yw}}}$, then:

$$C = \frac{1.57}{\left(\frac{D}{t_w}\right)^2} \left(\frac{Ek}{F_{yw}}\right) \quad (6.10.9.3.2-6)$$

C6.10.9.3.2

Stiffened interior web panels of nonhybrid and hybrid members satisfying Eq. 6.10.9.3.2-1 are capable of developing postbuckling shear resistance due to tension-field action (Basler, 1961; White et al., 2004). This action is analogous to that of the tension diagonals of a Pratt truss. The nominal shear resistance of these panels can be computed by summing the contributions of beam action and post-buckling tension-field action. The resulting expression is given in Eq. 6.10.9.3.2-2, where the first term in the bracket relates to either the shear yield or shear-buckling force and the second term relates to the postbuckling tension-field force. If Eq. 6.10.9.3.2-1 is not satisfied, the total area of the flanges within the panel is small relative to the area of the web and the full postbuckling resistance generally cannot be developed (White et al., 2004). However, it is conservative in these cases to use the postbuckling resistance given by Eq. 6.10.9.3.2-8. Eq. 6.10.9.3.2-8 gives the solution neglecting the increase in stress within the wedges of the web panel outside of the tension band implicitly included within the Basler model (Gaylord, 1963; Salmon and Johnson, 1996).

Within the restrictions specified by Eqs. 6.10.9.3.2-1 and 6.10.2.2-2 in general, and Article 6.10.9.3.1 for longitudinally-stiffened I-girders in particular, and provided that the maximum moment within the panel is utilized in checking the flexural resistance, White et al. (2004) shows that the equations of these Specifications sufficiently capture the resistance of a reasonably comprehensive body of experimental test results without the need to consider moment-shear interaction. In addition, the additional shear resistance and anchorage of tension field action provided by a composite deck are neglected within the shear resistance provisions of these Specifications. Also, the maximum moment and shear envelope values are typically used for design, whereas the maximum concurrent moment and shear values tend to be less critical. These factors provide some additional margin of conservatism beyond the sufficient level of safety obtained if these factors do not exist. Therefore, previous provisions related to the effects of moment-shear interaction are not required in these Specifications.

The coefficient, C , is equal to the ratio of the elastic buckling stress of the panel, computed assuming simply-supported boundary conditions, to the shear yield strength assumed to equal $F_{yw}/\sqrt{3}$. Eq. 6.10.9.3.2-6 is applicable only for C values not exceeding 0.8 (Basler, 1961). Above 0.8, C values are given by Eq. 6.10.9.3.2-5 until a limiting slenderness ratio is reached where the shear-buckling stress is equal to the shear yield strength and $C = 1.0$. Eq. 6.10.9.3.2-7 for the shear-buckling coefficient is a simplification of two exact equations for k that depend on the panel aspect ratio. The coefficients within Eqs. 6.10.9.3.2-4 through 6.10.9.3.2-6 have been modified slightly from the values given in previous Specifications to correct minor round-off errors.

in which:

k = shear-buckling coefficient

$$= 5 + \frac{5}{\left(\frac{d_o}{D}\right)^2} \quad (6.10.9.3.2-7)$$

Otherwise, the nominal shear resistance shall be taken as follows:

$$V_n = V_p \left[C + \frac{0.87(1-C)}{\left(\sqrt{1 + \left(\frac{d_o}{D}\right)^2} + \frac{d_o}{D}\right)} \right] \quad (6.10.9.3.2-8)$$

6.10.9.3.3—End Panels

The nominal shear resistance of a web end panel shall be taken as:

$$V_n = V_{cr} = CV_p \quad (6.10.9.3.3-1)$$

in which:

$$V_p = 0.58 F_{yw} D t_w \quad (6.10.9.3.3-2)$$

where:

C = ratio of the shear-buckling resistance to the shear yield strength determined by Eqs. 6.10.9.3.2-4, 6.10.9.3.2-5, or 6.10.9.3.2-6 as applicable

V_{cr} = shear-buckling resistance (kip)

V_p = plastic shear force (kip)

The transverse stiffener spacing for end panels with or without longitudinal stiffeners shall not exceed $1.5D$.

6.10.10—Shear Connectors

6.10.10.1—General

In composite sections, stud or channel shear connectors shall be provided at the interface between the concrete deck and the steel section to resist the interface shear.

Simple span composite bridges shall be provided with shear connectors throughout the length of the span.

Straight continuous composite bridges should normally be provided with shear connectors throughout the length of the bridge. In the negative flexure regions, shear connectors shall be provided where the longitudinal reinforcement is considered to be a part of the composite section. Otherwise, shear connectors need not be provided in negative flexure regions, but additional connectors shall be placed in the region of the points of permanent load contraflexure as specified in Article 6.10.10.3.

Because the slenderness of webs without longitudinal stiffeners is limited to 150 according to the provisions of Article 6.10.2.1.1, the separate handling requirement given in previous Specifications for web panels without longitudinal stiffeners is not required and is omitted in these Specifications.

C6.10.9.3.3

The shear in end panels adjacent to simple supports is limited to either the shear-yielding or shear-buckling resistance given by Eq. 6.10.9.3.3-1 in order to provide an anchor for the tension field in adjacent interior panels. The shear-buckling coefficient, k , to be used in determining the constant C in Eq. 6.10.9.3.3-1 is to be calculated based on the spacing from the support to the first stiffener adjacent to the support, which may not exceed $1.5D$.

C6.10.10.1

Shear connectors help control cracking in regions of negative flexure where the deck is subject to tensile stress and has longitudinal reinforcement.

Where shear connectors are omitted in negative flexure regions, the longitudinal reinforcement shall be extended into the positive flexure region as specified in Article 6.10.1.7.

Curved continuous composite bridges shall be provided with shear connectors throughout the length of the bridge.

6.10.10.1.1—Types

Stud and channel shear connectors shall be designed by the provisions of this Article.

Shear connectors should be of a type that permits a thorough compaction of the concrete to ensure that their entire surfaces are in contact with the concrete. The connectors shall be capable of resisting both horizontal and vertical movement between the concrete and the steel.

The ratio of the height to the diameter of a stud shear connector shall not be less than 4.0.

Channel shear connectors shall have fillet welds not smaller than 0.1875 in. placed along the heel and toe of the channel.

6.10.10.1.2—Pitch

The pitch of the shear connectors shall be determined to satisfy the fatigue limit state, as specified in Article 6.10.10.2 and 6.10.10.3. The resulting number of shear connectors shall not be less than the number required to satisfy the strength limit state as specified in Article 6.10.10.4.

The pitch, p , of shear connectors shall satisfy:

$$p \leq \frac{nZ_r}{V_{sr}} \quad (6.10.10.1.2-1)$$

in which:

V_{sr} = horizontal fatigue shear range per unit length (kip/in.)

$$= \sqrt{(V_{fat})^2 + (F_{fat})^2} \quad (6.10.10.1.2-2)$$

V_{fat} = longitudinal fatigue shear range per unit length (kip/in.)

$$= \frac{V_f Q}{I} \quad (6.10.10.1.2-3)$$

F_{fat} = radial fatigue shear range per unit length (kip/in.) taken as the larger of either:

Shear connectors are to be provided in regions of negative flexure in curved continuous bridges because torsional shear exists and is developed in the full composite section along the entire bridge. For bridges containing one or more curved segments, the effects of curvature usually extend beyond the curved segment. Therefore, it is conservatively specified that shear connectors be provided along the entire length of the bridge in this case as well.

C6.10.10.1.2

At the fatigue limit state, shear connectors are designed for the range of live load shear between the deck and top flange of the girder. In straight girders, the shear range normally is due to only major-axis bending if torsion is ignored. Curvature, skew and other conditions may cause torsion, which introduces a radial component of the horizontal shear. These provisions provide for consideration of both of the components of the shear to be added vectorially according to Eq. 6.10.10.1.2-2.

The parameters I and Q should be determined using the deck within the effective flange width. However, in negative flexure regions of straight girders only, the parameters I and Q may be determined using the longitudinal reinforcement within the effective flange width for negative moment, unless the concrete deck is considered to be effective in tension for negative moment in computing the range of the longitudinal stress, as permitted in Article 6.6.1.2.1.

The maximum longitudinal fatigue shear range, V_{fat} , is produced by placing the fatigue live load immediately to the left and to the right of the point under consideration. For the load in these positions, positive moments are produced over significant portions of the girder length. Thus, the use of the full composite section, including the concrete deck, is reasonable for determining the stiffness used to determine the shear range along the entire span. Also, the horizontal shear force in the deck is most often considered to be effective along the entire span in the analysis. To satisfy

$$F_{fat1} = \frac{A_{bot}\sigma_{fkg}\ell}{wR} \quad (6.10.10.1.2-4)$$

or:

$$F_{fat2} = \frac{F_{rc}}{w} \quad (6.10.10.1.2-5)$$

where:

- σ_{fkg} = range of longitudinal fatigue stress in the bottom flange without consideration of flange lateral bending (ksi)
- A_{bot} = area of the bottom flange (in.²)
- F_{rc} = net range of cross-frame or diaphragm force at the top flange (kip)
- I = moment of inertia of the short-term composite section (in.⁴)
- ℓ = distance between brace points (ft)
- n = number of shear connectors in a cross-section
- p = pitch of shear connectors along the longitudinal axis (in.)
- Q = first moment of the transformed short-term area of the concrete deck about the neutral axis of the short-term composite section (in.³)
- R = minimum girder radius within the panel (ft)
- V_f = vertical shear force range under the applicable fatigue load combination specified in Table 3.4.1-1 with the fatigue live load taken as specified in Article 3.6.1.4 (kip)
- w = effective length of deck (in.) taken as 48.0 in., except at end supports where w may be taken as 24.0 in.
- Z_r = shear fatigue resistance of an individual shear connector determined as specified in Article 6.10.10.2 (kip)

For straight spans or segments, the radial fatigue shear range from Eq. 6.10.10.1.2-4 may be taken equal to zero. For straight or horizontally curved bridges with skews not exceeding 20 degrees, the radial fatigue shear range from Eq. 6.10.10.1.2-5 may be taken equal to zero.

The center-to-center pitch of shear connectors shall not exceed 24.0 in. and shall not be less than six stud diameters.

6.10.10.1.3—Transverse Spacing

Shear connectors shall be placed transversely across the top flange of the steel section and may be spaced at regular or variable intervals.

Stud shear connectors shall not be closer than 4.0 stud diameters center-to-center transverse to the longitudinal axis of the supporting member.

this assumption, the shear force in the deck should be developed along the entire span. For straight girders, an option is permitted to ignore the concrete deck in computing the shear range in regions of negative flexure, unless the concrete is considered to be effective in tension in computing the range of the longitudinal stress, in which case the shear force in the deck must be developed. If the concrete is ignored in these regions, the maximum pitch specified at the end of this Article must not be exceeded.

The radial shear range, F_{fat} , typically is determined for the fatigue live load positioned to produce the largest positive and negative major-axis bending moments in the span. Therefore, vectorial addition of the longitudinal and radial components of the shear range is conservative because the longitudinal and radial shears are not produced by concurrent loads.

Eq. 6.10.10.1.2-4 may be used to determine the radial fatigue shear range resulting from the effect of any curvature between brace points. The shear range is taken as the radial component of the maximum longitudinal range of force in the bottom flange between brace points, which is used as a measure of the major-axis bending moment. The radial shear range is distributed over an effective length of girder flange, w . At end supports, w is halved. Eq. 6.10.10.1.2-4 gives the same units as V_{fat} .

Eq. 6.10.10.1.2-5 will typically govern the radial fatigue shear range where torsion is caused by effects other than curvature, such as skew. Eq. 6.10.10.1.2-5 is most likely to control when discontinuous cross-frame or diaphragm lines are used in conjunction with skew angles exceeding 20 degrees in either a straight or horizontally curved bridge. For all other cases, F_{rc} can be taken equal to zero. Eqs. 6.10.10.1.2-4 and 6.10.10.1.2-5 yield approximately the same value if the span or segment is curved and there are no other sources of torsion in the region under consideration. Note that F_{rc} represents the resultant range of horizontal force from all cross-frames or diaphragms at the point under consideration due to the factored fatigue load plus impact that is resisted by the shear connectors. In lieu of a refined analysis, F_{rc} may be taken as 25.0 kips for an exterior girder, which is typically the critical girder. F_{rc} should not be multiplied by the factor 0.75 discussed in Article C6.6.1.2.1.

Eqs. 6.10.10.1.2-4 and 6.10.10.1.2-5 are provided to ensure that a load path is provided through the shear connectors to satisfy equilibrium at a transverse section through the girders, deck, and cross-frame or diaphragm.

The clear distance between the edge of the top flange and the edge of the nearest shear connector shall not be less than 1.0 in.

6.10.10.1.4—Cover and Penetration

The clear depth of concrete cover over the tops of the shear connectors should not be less than 2.0 in. Shear connectors should penetrate at least 2.0 in. into the concrete deck.

6.10.10.2—Fatigue Resistance

The fatigue shear resistance of an individual stud shear connector, Z_r , shall be taken as:

For stud type shear connectors:

- Where the projected 75-year single lane Average Daily Truck Traffic ($ADTT$)_{SL} is greater than or equal to 960 trucks per day, the Fatigue I load combination shall be used and the fatigue shear resistance for infinite life shall be taken as:

$$Z_r = 5.5d^2 \quad (6.10.10.2-1)$$

- Otherwise, the Fatigue II load combination shall be used and the fatigue shear resistance for finite life shall be taken as:

$$Z_r = \alpha d^2 \quad (6.10.10.2-2)$$

in which:

$$\alpha = 34.5 - 4.28 \log N \quad (6.10.10.2-3)$$

For channel-type shear connectors:

- Where the projected 75-year single lane Average Daily Truck Traffic ($ADTT$)_{SL} is greater than or equal to 1850 trucks per day, the Fatigue I load combination shall be used and the fatigue shear resistance for infinite life shall be taken as:

$$Z_r = 2.1w \quad (6.10.10.2-4)$$

- Otherwise, the Fatigue II load combination shall be used and the fatigue shear resistance for finite life shall be taken as:

$$Z_r = Bw \quad (6.10.10.2-5)$$

in which:

$$B = 9.37 - 1.08 \log N \quad (6.10.10.2-6)$$

where:

C6.10.10.1.4

Stud shear connectors should penetrate through the haunch between the bottom of the deck and the top flange, if present, and into the deck. Otherwise, the haunch should be reinforced to contain the stud connector and develop its load in the deck.

C6.10.10.2

For the development of this information, see Slutter and Fisher (1966).

The values of ($ADTT$)_{SL} specified in this Article were determined by equating infinite and finite life resistances with due regard to the difference in load factors used with the Fatigue I and Fatigue II load combinations. A fatigue design life of 75 yr and a number of stress range cycles per truck passage, n , equal to 1.0 were also assumed. For other values of the fatigue design life, the specified value of ($ADTT$)_{SL} for stud shear connectors should be modified by multiplying the value by the ratio of 71,768 divided by the fatigue life sought in years; the specified value of ($ADTT$)_{SL} for channel shear connectors should be modified by multiplying the value by the ratio of 138,488 divided by the fatigue life sought in years. For other values of n , the values of ($ADTT$)_{SL} should be modified by dividing by the appropriate value of n taken from Table 6.6.1.2.5-2.

- $(ADTT)_{SL}$ = single-lane $ADTT$ as specified in Article 3.6.1.4.2
- d = diameter of the stud (in.)
- N = number of cycles specified in Article 6.6.1.2.5
- w = length of the channel measured transverse to the direction of the flange (in.)

The pitch shall be determined from Eq. 6.10.10.1.2-1 using the value of Z_r and the shear force range V_{sr} .

The effect of the shear connector on the fatigue resistance of the flange shall be investigated using the provisions of Article 6.6.1.2.

6.10.10.3—Special Requirements for Points of Permanent Load Contraflexure

For members that are noncomposite for negative flexure in the final condition, additional shear connectors shall be provided in the region of points of permanent load contraflexure.

The number of additional connectors, n_{ac} , shall be taken as:

$$n_{ac} = \frac{A_s f_{sr}}{Z_r} \quad (6.10.10.3-1)$$

where:

- A_s = total area of longitudinal reinforcement over the interior support within the effective concrete deck width (in.²)
- f_{sr} = stress range in the longitudinal reinforcement over the interior support under the applicable Fatigue load combination specified in Table 3.4.1-1 with the fatigue live load taken as specified in Article 3.6.1.4 (ksi)
- Z_r = fatigue shear resistance of an individual shear connector determined as specified in Article 6.10.10.2 (kip)

The additional shear connectors shall be placed within a distance extending one-third of the effective flange width specified in Article 4.6.2.6 from each side of the point of steel dead load contraflexure. The center-to-center pitch of all connectors, including the additional connectors, within that distance shall satisfy the maximum and minimum pitch requirements specified in Article 6.10.10.1.2. Field splices should be placed so as not to interfere with the shear connectors.

6.10.10.4—Strength Limit State

6.10.10.4.1—General

The factored shear resistance of a single shear connector, Q_r , at the strength limit state shall be taken as:

C6.10.10.3

The purpose of the additional connectors is to develop the reinforcing bars used as part of the negative flexural composite section.

$$Q_r = \phi_{sc} Q_n \quad (6.10.10.4.1-1)$$

where:

Q_n = nominal shear resistance of a single shear connector determined as specified in Article 6.10.10.4.3 (kip)

ϕ_{sc} = resistance factor for shear connectors specified in Article 6.5.4.2

At the strength limit state, the minimum number of shear connectors, n , over the region under consideration shall be taken as:

$$n = \frac{P}{Q_r} \quad (6.10.10.4.1-2)$$

where:

P = total nominal shear force determined as specified in Article 6.10.10.4.2 (kip)

Q_r = factored shear resistance of one shear connector determined from Eq. 6.10.10.4.1-1 (kip)

6.10.10.4.2—Nominal Shear Force

For simple spans and for continuous spans that are noncomposite for negative flexure in the final condition, the total nominal shear force, P , between the point of maximum positive design live load plus impact moment and each adjacent point of zero moment shall be taken as:

$$P = \sqrt{P_p^2 + F_p^2} \quad (6.10.10.4.2-1)$$

in which:

P_p = total longitudinal force in the concrete deck at the point of maximum positive live load plus impact moment (kip) taken as the lesser of either:

$$P_{1p} = 0.85 f'_c b_s t_s \quad (6.10.10.4.2-2)$$

or

$$P_{2p} = F_{yw} D t_w + F_{yt} b_{ft} t_{ft} + F_{yc} b_{fc} t_{fc} \quad (6.10.10.4.2-3)$$

F_p = total radial force in the concrete deck at the point of maximum positive live load plus impact moment (kip) taken as:

$$F_p = P_p \frac{L_p}{R} \quad (6.10.10.4.2-4)$$

where:

C6.10.10.4.2

Composite beams in which the longitudinal spacing of shear connectors has been varied according to the intensity of shear and duplicate beams where the number of connectors were essentially uniformly spaced have exhibited essentially the same ultimate strength and the same amount of deflection at service loads. Only a slight deformation in the concrete and the more heavily stressed connectors are needed to redistribute the horizontal shear to other less heavily stressed connectors. The important consideration is that the total number of connectors be sufficient to develop the nominal longitudinal force, P_n , on either side of the point of maximum design live load plus impact moment.

The point of maximum design live load plus impact moment is specified because it applies to the composite section and is easier to locate than a maximum of the sum of the moments acting on the composite section.

For continuous spans that are noncomposite for negative flexure in the final condition, points of zero moment within the span should be taken as the points of steel dead load contraflexure.

For continuous spans that are composite for negative flexure in the final condition, sufficient shear connectors are required to transfer the ultimate tensile force in the reinforcement from the concrete deck to the steel section. The number of shear connectors required between points of maximum positive design live load plus impact moment and the centerline of an adjacent interior support is computed from the sum of the critical forces at the maximum positive and negative moment locations. Since

- b_s = effective width of the concrete deck (in.)
 L_p = arc length between an end of the girder and an adjacent point of maximum positive live load plus impact moment (ft)
 R = minimum girder radius over the length, L_p (ft)
 t_s = thickness of the concrete deck (in.)

For straight spans or segments, F_p may be taken equal to zero.

For continuous spans that are composite for negative flexure in the final condition, the total nominal shear force, P , between the point of maximum positive design live load plus impact moment and an adjacent end of the member shall be determined from Eq. 6.10.10.4.2-1. The total nominal shear force, P , between the point of maximum positive design live load plus impact moment and the centerline of an adjacent interior support shall be taken as:

$$P = \sqrt{P_T^2 + F_T^2} \quad (6.10.10.4.2-5)$$

in which:

- P_T = total longitudinal force in the concrete deck between the point of maximum positive live load plus impact moment and the centerline of an adjacent interior support (kip) taken as:

$$P_T = P_p + P_n \quad (6.10.10.4.2-6)$$

- P_n = total longitudinal force in the concrete deck over an interior support (kip) taken as the lesser of either:

$$P_{1n} = F_{yw} D t_w + F_{yt} b_{ft} t_{ft} + F_{yc} b_{fc} t_{fc} \quad (6.10.10.4.2-7)$$

or:

$$P_{2n} = 0.45 f_c' b_s t_s \quad (6.10.10.4.2-8)$$

- F_T = total radial force in the concrete deck between the point of maximum positive live load plus impact moment and the centerline of an adjacent interior support (kip) taken as:

$$F_T = P_T \frac{L_n}{R} \quad (6.10.10.4.2-9)$$

where:

- L_n = arc length between the point of maximum positive live load plus impact moment and the centerline of an adjacent interior support (ft)
 R = minimum girder radius over the length, L_n (ft)

there is no point where moment always changes sign, many shear connectors resist reversing action in the concrete deck depending on the live load position. However, the required number of shear connectors is conservatively determined from the sum of the critical forces at the maximum moment locations to provide adequate shear resistance for any live load position.

The tension force in the deck given by Eq. 6.10.10.4.2-8 is defined as 45 percent of the specified 28-day compressive strength of the concrete. This is a conservative approximation to account for the combined contribution of both the longitudinal reinforcement and also the concrete that remains effective in tension based on its modulus of rupture. A more precise value may be substituted.

The radial effect of curvature is included in Eqs. 6.10.10.4.2-4 and 6.10.10.4.2-9. For curved spans or segments, the radial force is required to bring into equilibrium the smallest of the longitudinal forces in either the deck or the girder. When computing the radial component, the longitudinal force is conservatively assumed to be constant over the entire length L_p or L_n , as applicable.

For straight spans or segments, F_T may be taken equal to zero.

6.10.10.4.3—Nominal Shear Resistance

The nominal shear resistance of one stud shear connector embedded in a concrete deck shall be taken as:

$$Q_n = 0.5A_{sc}\sqrt{f'_cE_c} \leq A_{sc}F_u \quad (6.10.10.4.3-1)$$

where:

- A_{sc} = cross-sectional area of a stud shear connector (in.²)
- E_c = modulus of elasticity of the deck concrete determined as specified in Article 5.4.2.4 (ksi)
- F_u = specified minimum tensile strength of a stud shear connector determined as specified in Article 6.4.4 (ksi)

The nominal shear resistance of one channel shear connector embedded in a concrete deck shall be taken as:

$$Q_n = 0.3(t_f + 0.5t_w)L_c\sqrt{f'_cE_c} \quad (6.10.10.4.3-2)$$

where:

- t_f = flange thickness of channel shear connector (in.)
- t_w = web thickness of channel shear connector (in.)
- L_c = length of channel shear connector (in.)

6.10.11—Stiffeners

6.10.11.1—Transverse Stiffeners

6.10.11.1.1—General

Transverse stiffeners shall consist of plates or angles welded or bolted to either one or both sides of the web.

Stiffeners in straight girders not used as connection plates shall be tight fit or attached at the compression flange, but need not be in bearing with the tension flange. Single-sided stiffeners on horizontally curved girders should be attached to both flanges. When pairs of transverse stiffeners are used on horizontally curved girders, they shall be fitted tightly or attached to both flanges.

Stiffeners used as connecting plates for diaphragms or cross-frames shall be attached to both flanges.

The distance between the end of the web-to-stiffener weld and the near edge of the adjacent web-to-flange or longitudinal stiffener-to-web weld shall not be less than $4t_w$, but shall not exceed the lesser of $6t_w$ and 4.0 in.

C6.10.10.4.3

Studies have defined stud shear connector strength as a function of both the concrete modulus of elasticity and concrete strength (Ollgaard et al., 1971). Note that an upper bound on stud shear strength is the product of the cross-sectional area of the stud times its ultimate tensile strength. Eq. 6.10.10.4.3-2 is a modified form of the formula for the resistance of channel shear connectors developed in Slutter and Driscoll (1965) that extended its use to lightweight as well as normal-weight concrete.

C6.10.11.1.1

When single-sided transverse stiffeners are used on horizontally curved girders, they should be attached to both flanges to help retain the cross-sectional configuration of the girder when subjected to torsion and to avoid high localized bending within the web. This is particularly important at the top flange due to the torsional restraint from the slab. The fitting of pairs of transverse stiffeners against the flanges, or attachment to both flanges, is required for the same reason.

The minimum distance between the end of the web-to-stiffener weld to the adjacent web-to-flange or longitudinal stiffener-to-web weld is specified to relieve flexing of the unsupported segment of the web to avoid fatigue-induced cracking of the stiffener-to-web welds, and to avoid inadvertent intersecting welds. The $6t_w$ -criterion for maximum distance is specified to avoid vertical buckling

6.10.11.1.2—Projecting Width

The width, b_s , of each projecting stiffener element shall satisfy:

$$b_s \geq 2.0 + \frac{D}{30} \quad (6.10.11.1.2-1)$$

and:

$$16t_p \geq b_s \geq b_f / 4 \quad (6.10.11.1.2-2)$$

where:

- b_f = for I-sections, full width of the widest compression flange within the field section under consideration; for tub sections, full width of the widest top flange within the field section under consideration; for closed box sections, the limit of $b_f/4$ does not apply (in.)
- t_p = thickness of the projecting stiffener element (in.)

6.10.11.1.3—Moment of Inertia

For transverse stiffeners adjacent to web panels in which neither panel supports a shear force, V_w , larger than the factored shear buckling resistance, $\phi_v V_{cr}$, the moment of inertia, I_t , of the transverse stiffener shall satisfy the smaller of the following limits:

$$I_t \geq I_{t1} \quad (6.10.11.1.3-1)$$

and:

$$I_t \geq I_{t2} \quad (6.10.11.1.3-2)$$

in which:

$$I_{t1} = bt_w^3 J \quad (6.10.11.1.3-3)$$

$$I_{t2} = \frac{D^4 \rho_t^{1.3}}{40} \left(\frac{F_{yw}}{E} \right)^{1.5} \quad (6.10.11.1.3-4)$$

$$J = \frac{2.5}{(d_o / D)^2} - 2.0 \geq 0.5 \quad (6.10.11.1.3-5)$$

of the unsupported web. The 4.0-in. criterion was arbitrarily selected to avoid a large unsupported length where the web thickness has been selected for reasons other than stability, e.g., webs of bascule girders at trunions.

C6.10.11.1.2

Eq. 6.10.11.1.2-1 is taken from Ketchum (1920). This equation tends to govern relative to Eq. 6.10.11.1.2-2 in I-girders with large D/b_f .

The full width of the widest compression flange within the field section under consideration is used for b_f in Eq. 6.10.11.1.2-2 to ensure a minimum stiffener width that will help restrain the widest compression flange. This requirement also conveniently allows for the use of the same minimum stiffener width throughout the entire field section, if desired. The widest top flange is used in Eq. 6.10.11.1.2-2 for tub sections since the bottom flange is restrained by a web along both of its edges. The limit of $b_f/4$ does not apply for closed box sections for the same reason.

C6.10.11.1.3

For the web to adequately develop the shear-buckling resistance or the combined shear-buckling and postbuckling tension-field resistance, the transverse stiffener must have sufficient rigidity to maintain a vertical line of near zero lateral deflection along the line of the stiffener. For ratios of (d_o/D) less than 1.0, much larger values of I_t are required to develop the shear-buckling resistance, as discussed in Bleich (1952) and represented by Eq. 6.10.11.1.3-1. For single stiffeners, a significant portion of the web is implicitly assumed to contribute to the bending rigidity such that the neutral axis of the stiffener is located close to the edge in contact with the web. Therefore, for simplicity, the neutral axis is assumed to be located at this edge and the contribution of the web to the moment of inertia about this axis is neglected. The term b in Eq. 6.10.11.1.3-1 replaces d_o in prior Specifications. This term and Eq. 6.10.11.1.3-5 give a constant value for the I_t required to develop the shear-buckling resistance for web panels with $d_o > D$ (Kim et al., 2004).

Eq. 6.10.11.1.3-1 requires excessively large stiffener sizes as D/t_w is reduced below $1.12\sqrt{Ek/F_{yw}}$, the web slenderness required for $C = 1$, since Eq. 6.10.11.1.3-1 is based on developing the web elastic shear-buckling

$$F_{crs} = \frac{0.31E}{\left(\frac{b_t}{t_p}\right)^2} \leq F_{ys} \quad (6.10.11.1.3-6)$$

$$V_{cr} = CV_p \quad (6.10.11.1.3-7)$$

$$V_p = 0.58F_{yw}Dt_w \quad (6.10.11.1.3-8)$$

where:

ϕ_v = resistance factor for shear specified in Article 6.5.4.2

V_{cr} = smaller of the nominal shear-buckling resistances of the adjacent web panels (kip)

V_u = larger of the shears in the adjacent web panels due to the factored loads (kip)

I_t = moment of inertia of the transverse stiffener taken about the edge in contact with the web for single stiffeners and about the mid-thickness of the web for stiffener pairs (in.⁴)

b = the smaller of d_o and D (in.)

d_o = the smaller of the adjacent web panel widths (in.)

J = stiffener bending rigidity parameter

ρ_t = the larger of F_{yw}/F_{crs} and 1.0

F_{crs} = local buckling stress for the stiffener (ksi)

F_{ys} = specified minimum yield strength of the stiffener (ksi)

C = ratio of the shear-buckling resistance to the shear yield strength determined by Eqs. 6.10.9.3.2-4, 6.10.9.3.2-5, or 6.10.9.3.2-6, as applicable. For web panels considered unstiffened, the shear buckling coefficient, k , shall be taken equal to 5.0

V_p = plastic shear force (kip)

For transverse stiffeners adjacent to web panels in which the shear force, V_u , is larger than the factored shear buckling resistance, $\phi_v V_{cr}$, and thus the web postbuckling or tension-field resistance is required in one or both panels, the moment of inertia, I_t , of the transverse stiffeners shall satisfy:

- If $I_{t2} > I_{t1}$, then:

$$I_t \geq I_{t1} + (I_{t2} - I_{t1}) \left(\frac{V_u - \phi_v V_{cr}}{\phi_v V_n - \phi_v V_{cr}} \right) \quad (6.10.11.1.3-9)$$

- Otherwise:

$$I_t \geq I_{t2} \quad (6.10.11.1.3-10)$$

where:

resistance. Inelastic buckling solutions using procedures from Bleich (1952) show that larger stiffeners are not required as D/t_w is reduced below this limit. These results are corroborated by refined FEA solutions (Kim et al., 2004). k is the shear-buckling coefficient defined in Article 6.10.9.

To develop the web shear postbuckling resistance associated with tension-field action, the transverse stiffeners generally must have a larger I_t than defined by Eq. 6.10.11.1.3-1. The I_t defined by Eq. 6.10.11.1.3-2, which for $\rho_t = 1$ is approximately equal to the value required by Eq. 6.10.11.1.3-1 for a web with $D/t_w = 1.12\sqrt{Ek/F_{yw}}$, provides an accurate to slightly conservative stiffener size relative to refined FEA solutions for straight and curved I-girders at all values of D/t_w permitted by these Specifications (Kim et al., 2004). Eq. 6.10.11.1.3-2 is an approximate upper bound to the results for all values of d_o/D from an equation recommended by Kim et al. (2004), recognizing that the stiffener demands are insensitive to this parameter.

Multiple research studies have shown that transverse stiffeners in I-girders designed for tension-field action are loaded predominantly in bending due to the restraint they provide to lateral deflection of the web. Generally, there is evidence of some axial compression in the transverse stiffeners due to the tension field, but even in the most slender web plates permitted by these Specifications, the effect of the axial compression transmitted from the postbuckled web plate is typically minor compared to the lateral loading effect. Therefore, the transverse stiffener area requirement from prior Specifications is no longer specified.

V_n = smaller of the nominal combined buckling and tension-field shear resistances of the adjacent web panels, determined as specified in Article 6.10.9.3.2 (kip)

Transverse stiffeners used in web panels with longitudinal stiffeners shall also satisfy:

$$I_t \geq \left(\frac{b_t}{b_\ell} \right) \left(\frac{D}{3.0d_o} \right) I_\ell \quad (6.10.11.1.3-11)$$

where:

b_t = projecting width of the transverse stiffener (in.)
 b_ℓ = projecting width of the longitudinal stiffener (in.)
 I_ℓ = moment of inertia of the longitudinal stiffener determined as specified in Article 6.10.11.3.3 (in.⁴)

For girders with single-sided stiffeners, Eq. 6.10.11.1.3-2 typically requires slightly larger stiffeners than in previous Specifications for small D/t_w slightly exceeding $1.12\sqrt{Ek/F_{yw}}$, where the I_t requirement comparable to Eq. 6.10.11.1.3-1 governs relative to the area requirement for single-sided stiffeners given in previous Specifications. For larger D/t_w values, Eq. 6.10.11.1.3-2 typically gives comparable or smaller single-sided stiffeners compared to the area requirement in previous Specifications at $V_u = \phi_v V_n$. For girders with stiffener pairs, the previous Specifications substantially underestimated the required stiffener size for increasing $D/t_w > 1.12\sqrt{Ek/F_{yw}}$. Eq. 6.10.11.1.3-2 recognizes the fact that single- and double-sided transverse stiffeners with the same I_t exhibit essentially identical performance (Horne and Grayson, 1983; Rahal and Harding, 1990; Stanway et al., 1996; Lee et al., 2003; Kim et al., 2004).

The term ρ_t in Eq. 6.10.11.1.3-2 accounts conservatively for the effect of early yielding in transverse stiffeners with $F_{ys} < F_{yw}$ and for the effect of potential local buckling of stiffeners having a relatively large width-to-thickness ratio b_t/t_p . The definition of the stiffener local buckling stress F_{crs} is retained from AASHTO (2004).

Eq. 6.10.11.1.3-9 accounts for the fact that the I_t necessary to develop a shear resistance greater than or equal to V_u is smaller when V_u is smaller than the full factored combined web shear buckling and post-buckling resistance, $\phi_v V_n$ (Kim et al., 2004). For large girder depths, the philosophy of providing a stiffener flexural rigidity sufficient to develop $V_u = \phi_v V_n$ leads to stiffener sizes that are significantly larger than typically selected using prior AASHTO Specifications, where the former area requirement for the stiffeners was reduced when V_u was less than $\phi_v V_n$. Eq. 6.10.11.1.3-9 allows the calculation of a conservative but more economical stiffener size for these larger girder depths sufficient to develop a girder shear resistance greater than or equal to V_u .

Eq. 6.10.11.1.3-10 addresses a small number of cases with stocky webs where V_n is approximately equal to V_p .

Lateral loads along the length of a longitudinal stiffener are transferred to the adjacent transverse stiffeners as concentrated reactions (Cooper, 1967). Eq. 6.10.11.1.3-11 gives a relationship between the moments of inertia of the longitudinal and transverse stiffeners to ensure that the latter does not fail under the concentrated reactions. This equation applies whether the stiffeners are on the same or opposite side of the web.

6.10.11.2—Bearing Stiffeners

6.10.11.2.1—General

Bearing stiffeners shall be placed on the webs of built-up sections at all bearing locations. At bearing locations on rolled shapes and at other locations on built-up sections or rolled shapes subjected to concentrated loads, where the loads are not transmitted through a deck or deck system, either bearing stiffeners shall be provided or the web shall satisfy the provisions of Article D6.5.

Bearing stiffeners shall consist of one or more plates or angles welded or bolted to both sides of the web. The connections to the web shall be designed to transmit the full bearing force due to the factored loads.

The stiffeners shall extend the full depth of the web and as closely as practical to the outer edges of the flanges.

Each stiffener shall be either milled to bear against the flange through which it receives its load or attached to that flange by a full penetration groove weld.

6.10.11.2.2—Projecting Width

The width, b_t , of each projecting stiffener element shall satisfy:

$$b_t \leq 0.48t_p \sqrt{\frac{E}{F_{ys}}} \quad (6.10.11.2.2-1)$$

where:

F_{ys} = specified minimum yield strength of the stiffener (ksi)

t_p = thickness of the projecting stiffener element (in.)

6.10.11.2.3—Bearing Resistance

The factored bearing resistance for the fitted ends of bearing stiffeners shall be taken as:

$$(R_{sb})_r = \phi_b (R_{sb})_n \quad (6.10.11.2.3-1)$$

in which:

$(R_{sb})_n$ = nominal bearing resistance for the fitted ends of bearing stiffeners (kip)

C6.10.11.2.1

Webs of built-up sections and rolled shapes without bearing stiffeners at the indicated locations must be investigated for the limit states of web local yielding and web crippling according to the procedures specified in Article D6.5. The section should either be modified to comply with these requirements or else bearing stiffeners designed according to these Specifications should be placed on the web at the location under consideration.

In particular, inadequate provisions to resist temporary concentrated loads during construction that are not transmitted through a deck or deck system can result in failures. The Engineer should be especially cognizant of this issue when girders are incrementally launched over supports.

C6.10.11.2.2

The provision specified in this Article is intended to prevent local buckling of the bearing stiffener plates.

C6.10.11.2.3

To bring bearing stiffener plates tight against the flanges, part of the stiffener must be clipped to clear the web-to-flange fillet weld. Thus, the area of direct bearing is less than the gross area of the stiffener. The bearing resistance is based on this bearing area and the yield strength of the stiffener.

The specified factored bearing resistance is approximately equivalent to the bearing strength given in AISC (2005). The nominal bearing resistance given by

$$= 1.4A_{pn}F_{ys} \quad (6.10.11.2.3-2)$$

where:

- ϕ_b = resistance factor for bearing specified in Article 6.5.4.2
- A_{pn} = area of the projecting elements of the stiffener outside of the web-to-flange fillet welds but not beyond the edge of the flange (in.²)
- F_{ys} = specified minimum yield strength of the stiffener (ksi)

6.10.11.2.4—Axial Resistance of Bearing Stiffeners

6.10.11.2.4a—General

The factored axial resistance, P_r , shall be determined as specified in Article 6.9.2.1 using the specified minimum yield strength of the stiffener plates F_{ys} . The radius of gyration shall be computed about the mid-thickness of the web and the effective length shall be taken as $0.75D$, where D is the web depth.

6.10.11.2.4b—Effective Section

For stiffeners bolted to the web, the effective column section shall consist of the stiffener elements only.

Except as noted herein, for stiffeners welded to the web, a portion of the web shall be included as part of the effective column section. For stiffeners consisting of two plates welded to the web, the effective column section shall consist of the two stiffener elements, plus a centrally located strip of web extending not more than $9t_w$ on each side of the stiffeners. If more than one pair of stiffeners is used, the effective column section shall consist of all stiffener elements, plus a centrally located strip of web extending not more than $9t_w$ on each side of the outer projecting elements of the group.

The strip of the web shall not be included in the effective section at interior supports of continuous-span hybrid members for which the specified minimum yield strength of the web is less than 70 percent of the specified minimum yield strength of the higher strength flange.

If the specified minimum yield strength of the web is less than that of the stiffener plates, the strip of the web included in the effective section shall be reduced by the ratio F_{yw}/F_{ys} .

6.10.11.3—Longitudinal Stiffeners

6.10.11.3.1—General

Where required, longitudinal stiffeners should consist of either a plate welded to one side of the web, or a bolted angle. Longitudinal stiffeners shall be located at a vertical position on the web such that Eq. 6.10.3.2.1-3 is satisfied when checking constructibility, Eq. 6.10.4.2.2-4 is

Eq. 6.10.11.2.3-2 is reduced from the nominal bearing resistance of $1.8A_{pn}F_{ys}$ specified in AISC (2005) to reflect the relative difference in the resistance factors for bearing given in the AISC and AASHTO LRFD Specifications.

C6.10.11.2.4a

The end restraint against column buckling provided by the flanges allows for the use of a reduced effective length. The specified minimum yield strength of the stiffener plates, F_{ys} , is to be used in the calculation of the axial resistance to account for the early yielding of the lower strength stiffener plates.

C6.10.11.2.4b

A portion of the web is assumed to act in combination with the bearing stiffener plates. This portion of the web is not included for the stated case at interior supports of continuous-span hybrid members with F_{yw} less than the specified value because of the amount of web yielding that may be expected due to longitudinal flexural stress in this particular case. At end supports of hybrid members, the web may be included regardless of the specified minimum yield strength of the web.

For unusual cases in which F_{ys} is larger than F_{yw} , the yielding of the lower strength web is accounted for in the stiffener axial resistance by adjusting the width of the web strip included in the effective section by F_{yw}/F_{ys} .

C6.10.11.3.1

For composite sections in regions of positive flexure, the depth of the web in compression D_c changes relative to the vertical position of a longitudinal web stiffener, which is usually a fixed distance from the compression flange, after the concrete deck has been placed. Thus, the

satisfied at the service limit state, and all the appropriate design requirements are satisfied at the strength limit state.

Wherever practical, longitudinal stiffeners shall extend uninterrupted over their specified length, unless otherwise permitted in the contract documents. If transverse web elements serving as stiffeners are interrupted by a longitudinal stiffener, the transverse element shall be attached to the longitudinal stiffener to develop the flexural and axial resistance of the transverse element.

The flexural stress in the longitudinal stiffener, f_s , due to the factored loads at the strength limit state and when checking constructibility shall satisfy:

$$f_s \leq \phi_f R_h F_{ys} \quad (6.10.11.3.1-1)$$

where:

- ϕ_f = resistance factor for flexure specified in Article 6.5.4.2
- F_{ys} = specified minimum yield strength of the stiffener (ksi)
- R_h = hybrid factor determined as specified in Article 6.10.1.10.1

computed web bend-buckling resistance is different before and after placement of the deck and is dependent on the loading. As a result, an investigation of several trial locations of the stiffener may be necessary to determine a location of the stiffener to satisfy Eq. 6.10.3.2.1-3 for constructibility, Eq. 6.10.4.2.2-4 at the service limit state and the appropriate design requirements at the strength limit state along the girder. The following equation may be used to determine an initial trial stiffener location for composite sections in regions of positive flexure:

$$\frac{d_s}{D_c} = \frac{1}{1 + 1.5 \sqrt{\frac{f_{DC1} + f_{DC2} + f_{DW} + f_{LL+IM}}{f_{DC1}}}} \quad (C6.10.11.3.1-1)$$

where:

- d_s = distance from the centerline of a plate longitudinal stiffener, or the gage line of an angle longitudinal stiffener, to the inner surface or leg of the compression-flange element (in.)
- D_c = depth of the web of the noncomposite steel section in compression in the elastic range (in.)
- f_{xx} = compression-flange stresses at the strength limit state caused by the different factored loads at the section with the maximum compressive flexural stress; i.e., $DC1$, the permanent load acting on the noncomposite section; $DC2$, the permanent load acting on the long-term composite section; DW , the wearing surface load; and $LL+IM$, acting on their respective sections (ksi). Flange lateral bending is to be disregarded in this calculation.

The stiffener may need to be moved vertically up or down from this initial trial location in order to satisfy all the specified limit-state criteria.

For composite sections in regions of negative flexure and for noncomposite sections, it is suggested that an initial trial stiffener location of $2D_c/5$ from the inner surface of the compression flange be examined at the section with the maximum flexural compressive stress due to the factored loads at the strength limit state. Furthermore, for composite sections, D_c should be computed for the section consisting of the steel girder plus the longitudinal deck reinforcement. The stiffener may need to be moved vertically up or down from the initial trial location in order to satisfy all the specified limit-state criteria, in particular for cases where the concrete deck is assumed effective in tension in regions of negative flexure at the service limit state, as permitted for composite sections satisfying the requirements specified in Article 6.10.4.2.1.

Theoretical and experimental studies on noncomposite girders have indicated that the optimum location of one longitudinal stiffener is $2D_c/5$ for bending and $D/2$ for

shear. Tests have also shown that longitudinal stiffeners located at $2D_c/5$ on these sections can effectively control lateral web deflections under flexure (Cooper, 1967). The distance $2D_c/5$ is recommended because shear is always accompanied by moment and because a properly proportioned longitudinal stiffener also reduces the web lateral deflections caused by shear. Also, because D_c may vary along the length of the span, it is recommended that the stiffener be located based on D_c computed at the section with the largest compressive flexural stress. Thus, the stiffener may not be located at its optimum location at other sections with a lower stress and a different D_c . These sections should also be examined to ensure that they satisfy the specified limit states.

In regions where the web undergoes stress reversal, it may be necessary, or desirable, to use two longitudinal stiffeners on the web.

It is preferred that longitudinal stiffeners be placed on the opposite side of the web from transverse intermediate stiffeners. Otherwise, at bearing stiffeners and connection plates where the longitudinal stiffener and the transverse web element must intersect, the longitudinal stiffener must be made continuous wherever practical, unless permitted otherwise in the contract documents, since longitudinal stiffeners are designed as continuous members. Discontinuous transverse web elements must be fitted and attached to both sides of the longitudinal stiffener with connections sufficient to develop the flexural and axial resistance of the transverse element. Should the longitudinal stiffener be interrupted, it should be similarly attached to all transverse web elements. All interruptions must be carefully designed with respect to fatigue, particularly if the longitudinal stiffener is not attached to the transverse web elements. Where the longitudinal stiffener is attached to the transverse web elements, Eq. 6.6.1.2.5-3 may apply.

For various stiffener end details and their associated fatigue details, refer to Schilling (1986). Copes should always be provided to avoid intersecting welds. Where longitudinal stiffeners are discontinued at bolted field splices, consideration should be given to taking the stiffener to the free edge of the web where the normal stress is zero.

Longitudinal stiffeners are subject to the same flexural strain as the web at their vertical position on the web. Therefore, they must have sufficient rigidity and strength to resist bend-buckling of the web, where required to do so, and to transmit the stresses in the stiffener and a portion of the web as an equivalent column (Cooper, 1967). Thus, full nominal yielding of the stiffeners is not permitted at the strength limit state and when checking constructibility as an upper bound. Eq. 6.10.11.3.1-1 serves as a limit on the validity of Eq. 6.10.11.3.3-2, which is in turn based on the axial resistance of an equivalent column section composed of the stiffener and a portion of the web plate. To account for the influence of web yielding on the longitudinal stiffener stress in hybrid members, the

6.10.11.3.2—Projecting Width

The projecting width, b_ℓ , of the stiffener shall satisfy:

$$b_\ell \leq 0.48t_s \sqrt{\frac{E}{F_{ys}}} \quad (6.10.11.3.2-1)$$

where:

t_s = thickness of the stiffener (in.)

6.10.11.3.3—Moment of Inertia and Radius of Gyration

Longitudinal stiffeners shall satisfy:

$$I_\ell \geq Dt_w^3 \left[2.4 \left(\frac{d_o}{D} \right)^2 - 0.13 \right] \beta \quad (6.10.11.3.3-1)$$

and:

$$r \geq \frac{0.16d_o \sqrt{\frac{F_{ys}}{E}}}{\sqrt{1 - 0.6 \frac{F_{yc}}{R_h F_{ys}}}} \quad (6.10.11.3.3-2)$$

in which:

β = curvature correction factor for longitudinal stiffener rigidity calculated as follows:

- For cases where the longitudinal stiffener is on the side of the web away from the center of curvature:

$$\beta = \frac{Z}{6} + 1 \quad (6.10.11.3.3-3)$$

For cases where the longitudinal stiffener is on the side of the web toward the center of curvature:

$$\beta = \frac{Z}{12} + 1 \quad (6.10.11.3.3-4)$$

Z = curvature parameter:

$$= \frac{0.95d_o^2}{Rt_w} \leq 10 \quad (6.10.11.3.3-5)$$

where:

elastically computed stress in the stiffener is limited to $\phi R_h F_{ys}$ in Eq. 6.10.11.3.1-1. For the strength limit state and constructibility checks, the corresponding value of R_h at the section under consideration should be applied in Eq. 6.10.11.3.1-1.

C6.10.11.3.2

This requirement is intended to prevent local buckling of the longitudinal stiffener.

C6.10.11.3.3

Eq. 6.10.11.3.3-1 ensures that the stiffener will have adequate rigidity to maintain a horizontal line of near zero lateral deflection in the web panel when necessary to resist bend-buckling of the web (Galambos, 1998). Eq. 6.10.11.3.3-2 ensures that the longitudinal stiffener acting in combination with an adjacent strip of the web will withstand the axial compressive stress without lateral buckling. The moment of inertia, I_ℓ , and radius of gyration, r , are taken about the neutral axis of an equivalent column cross-section composed of the stiffener and an adjacent strip of the web, as suggested by Cooper (1967). Previous Specifications required that these quantities be calculated about the edge of the stiffener in contact with the web plate. The values for I_ℓ and for r calculated as suggested by Cooper (1967) are generally smaller than the corresponding values determined as suggested in the previous Specifications. The specified procedure for calculation of I_ℓ and r is consistent with the horizontally-curved I-girder provisions of AASHTO (2003) in the limit that the girder is straight. The effect of the web plate having a lower yield strength than that of the longitudinal stiffener is accommodated by adjusting the web strip that contributes to the effective column section by F_{yw}/F_{ys} in the calculation of the moment of inertia of the longitudinal stiffener.

The rigidity required of longitudinal stiffeners on curved webs is greater than the rigidity required on straight webs because of the tendency of curved webs to bow. The factor β in Eq. 6.10.11.3.3-1 is a simplification of the requirement in the Hanshin (1988) provisions for longitudinal stiffeners used on curved girders. For longitudinal stiffeners on straight webs, Eq. 6.10.11.3.3-5 leads to $\beta = 1.0$.

Eq. 6.10.11.3.3-2 is based on the model described by Cooper (1967), except that the possibility of different specified minimum yield strengths for the stiffener and compression flange is accommodated. Also, the influence of a hybrid web is approximated by including the hybrid

- d_o = transverse stiffener spacing (in.)
 I_ℓ = moment of inertia of the longitudinal stiffener including an effective width of the web equal to $18t_w$, taken about the neutral axis of the combined section (in.⁴). If F_{yw} is smaller than F_{ys} , the strip of the web included in the effective section shall be reduced by the ratio F_{yw}/F_{ys}
 R = minimum girder radius in the panel (in.)
 r = radius of gyration of the longitudinal stiffener including an effective width of the web equal to $18t_w$, taken about the neutral axis of the combined section (in.)

factor, R_b , within this equation. For a nonhybrid I-section, the required radius of gyration from Eq. 6.10.11.3.3-2 is slightly larger than that required in previous Specifications. For an I-section in which F_{yc}/F_{ys} is greater than one, the required radius of gyration from Eq. 6.10.11.3.3-2 is significantly larger than required in previous Specifications. This is necessary because in these cases, the longitudinal stiffener is subjected to larger stresses compared to its resistance as an equivalent column than in an equivalent homogeneous section.

Article 6.10.9.3.1 requires that the shear resistance of the web panel be determined based on the total web depth D . Therefore, no area requirement is given for the longitudinal stiffeners to anchor the tension field.

6.10.12—Cover Plates

6.10.12.1—General

The length of any cover plate, L_{cp} , in ft, added to a member shall satisfy:

$$L_{cp} \geq \frac{d}{6.0} + 3.0 \quad (6.10.12.1-1)$$

where:

- d = total depth of the steel section (in.)

Partial length welded cover plates shall not be used on flanges more than 0.8 in. thick for nonredundant load path structures subjected to repetitive loadings that produce tension or reversal of stress in the flange.

The maximum thickness of a single cover plate on a flange shall not be greater than two times the thickness of the flange to which the cover plate is attached. Multiple welded cover plates shall not be permitted.

Cover plates may either be wider or narrower than the flange to which they are attached.

6.10.12.2—End Requirements

6.10.12.2.1—General

The theoretical end of the cover plate shall be taken as the section where the moment, M_u , or flexural stress, f_{bu} , due to the factored loads equals the factored flexural resistance of the flange. The cover plate shall be extended beyond the theoretical end far enough so that:

- The stress range at the actual end satisfies the appropriate fatigue requirements specified in Article 6.6.1.2, and
- The longitudinal force in the cover plate due to the factored loads at the theoretical end can be developed by welds and/or bolts placed between the theoretical and actual ends.

The width at ends of tapered cover plates shall not be less than 3.0 in.

6.10.12.2.2—Welded Ends

The welds connecting the cover plate to the flange between the theoretical and actual ends shall be adequate to develop the computed force in the cover plate at the theoretical end.

Where cover plates are wider than the flange, welds shall not be wrapped around the ends of the cover plate.

6.10.12.2.3—Bolted Ends

The bolts in the slip-critical connections of the cover plate to the flange between the theoretical and actual ends shall be adequate to develop the force due to the factored loads in the cover plate at the theoretical end.

The slip resistance of the end-bolted connection shall be determined in accordance with Article 6.13.2.8. The longitudinal welds connecting the cover plate to the flange shall be continuous and shall stop a distance equal to one bolt spacing before the first row of bolts in the end-bolted portion. Where end-bolted cover plates are used, the contract documents shall specify that they be installed in the following sequence:

- Drill holes,
- Clean faying surfaces,
- Install bolts, and
- Weld plates.

6.11—BOX-SECTION FLEXURAL MEMBERS

6.11.1—General

The provisions of this Article apply to flexure of straight or horizontally curved steel single or multiple closed-box or tub sections in simple or continuous bridges of moderate length. The provisions cover the design of composite, hybrid and nonhybrid, and constant and variable web depth members as defined by and subject to the requirements of Article 6.10.1.1, Articles 6.10.1.3 through 6.10.1.8, and Articles 6.11.1.1 through 6.11.1.4. The provisions of Article 6.10.1.6 shall apply only to the top flanges of tub sections.

Single box sections shall be positioned in a central position with respect to the cross-section, and the center of gravity of the dead load shall be as close to the shear center of the box as is practical. These provisions shall not be applied to multiple cell single box sections, or to composite box flanges used as bottom flanges.

All types of box-section flexural members shall be designed as a minimum to satisfy:

C6.10.12.2.3

Research on end-bolted cover plates is discussed in Wattar et al. (1985).

C6.11.1

Article 6.11.1 addresses general topics that apply to closed-box and tub sections used as flexural members in either straight bridges, horizontally curved bridges, or bridges containing both straight and curved segments. For the application of the provisions of Article 6.11, bridges containing both straight and curved segments are to be treated as horizontally curved bridges since the effects of curvature on the support reactions and girder deflections, as well as the effects of flange lateral bending and torsional shear, usually extend beyond the curved segments. The term moderate length as used herein refers to bridges of spans up to approximately 350 ft. The provisions may be applied to larger spans based on a thorough evaluation of the application of the bridge under consideration consistent with basic structural fundamentals. Alternative information regarding the design of long-span steel box-girder bridges is contained in FHWA (1980). For general overview on box-girder bridges, refer to Wolchuk (1997).

- The cross-section proportion limits specified in Article 6.11.2;
- The constructibility requirements specified in Article 6.11.3;
- The service limit state requirements specified in Article 6.11.4;
- The fatigue and fracture limit state requirements specified in Article 6.11.5;
- The strength limit state requirements specified in Article 6.11.6.

The web bend-buckling resistance in slender web members shall be determined as specified in Article 6.10.1.9. Flange-strength reduction factors in hybrid and/or slender web members shall be determined as specified in Article 6.10.1.10.

Internal and external cross-frames and diaphragms for box sections shall satisfy the provisions of Article 6.7.4. Top flange bracing for tub sections shall satisfy the provisions of Article 6.7.5.

The five bullet items in this Article indicate the overarching organization of the subsequent provisions for the design of box-section flexural members. To avoid repetition, some of the general topics in this Article refer back to the general provisions of Article 6.10.1 for I-sections, which apply equally well to box sections. Where necessary, other Articles in Article 6.10 are referred to at appropriate points within Article 6.11.

Within these provisions, the term box flange refers to a flange plate connected to two webs.

These provisions do not apply to the use of box sections which are noncomposite in the final condition, as defined in Article 6.10.1.2, as flexural members. The concrete deck is to be assumed effective over the entire span length in the analysis for loads applied to the composite section according to the provisions of Article 6.10.1.5. Therefore, shear connectors must be present along the entire span to resist the torsional shear that exists along the entire span in all types of composite box sections in order to avoid possible debonding of the deck. Shear connectors must also be present in regions of negative flexure in order to be consistent with the prototype and model bridges that were studied in the original development of the live-load distribution provisions for box sections (Johnston and Mattock, 1967). For considerations while a composite box section is under construction, applicable provisions of Articles 6.10 and 6.11 may be utilized depending on whether the section is thought to be effectively open or quasi-box in behavior, respectively. The flexural resistance of noncomposite closed-box sections used as compression or tension members is specified in Article 6.12.2.2.2.

These provisions may be applied to the use of composite closed-box sections, or sections utilizing a steel plate for the top flange that is composite with the concrete deck, as flexural members. The use of such sections has been relatively rare in the U.S. to date due to cost considerations related to the implementation of necessary safety requirements for working inside of closed boxes. These Specifications do not apply to the use of composite concrete on bottom box flanges in order to stiffen the flanges in regions of negative flexure.

The use of single-box sections is permitted in these Specifications because torsional equilibrium can be established with two bearings at some supports. Placing the center of gravity of the dead load near the shear center of single-box sections ensures minimal torsion. Items such as sound barriers on one side of the bridge may be critical on single-box sections.

These Specifications do not apply to multiple cell single box sections because there has been little published research in the U.S. regarding these members. Analysis of this bridge type involves consideration of shear flow in each cell.

In variable web depth box members with inclined webs, the inclination of the webs should preferably remain constant in order to simplify the analysis and the fabrication. For a constant distance between the webs at the top of the box, which is also preferred, this requires that the width of the bottom flange vary along the length

and that the web heights at a given cross-section be kept equal. If the bridge is to incrementally launched, a constant depth box is recommended.

The provisions of Article 6.11 provide a unified approach for consideration of combined major-axis bending and flange lateral bending from any source in the design of top flanges of tub sections during construction. These provisions also provide a unified approach for consideration of the combined effects of normal stress and St. Venant torsional shear stress in closed-box and tub sections both during construction and in the final constructed condition. General design equations are provided for determining the nominal flexural resistance of box flanges under the combined effects of normal stress and torsional shear stress. The provisions also allow for the consideration of torsional shear in the design of the box-section webs and shear connectors. For straight boxes, the effects of torsional shear are typically relatively small unless the bridge is subjected to large torques. For example, boxes resting on skewed supports are usually subjected to large torques. For horizontally curved boxes, flange lateral bending effects due to curvature and the effects of torsional shear must always be considered at all limit states and also during construction.

For cases where the effects of the flange lateral bending and/or torsional shear are judged to be insignificant or incidental, or are not to be considered, the terms related to these effects are simply set equal to zero in the appropriate equations. The format of the equations then simply reduces to the format of the more familiar equations given in previous Specifications for checking the nominal flexural resistance of box sections in the absence of flange lateral bending and St. Venant torsion.

Fundamental calculations for flexural members previously found in Article 6.10.3 of AASHTO (2004) have been placed in Appendix D6.

6.11.1.1—Stress Determinations

Box flanges in multiple and single box sections shall be considered fully effective in resisting flexure if the width of the flange does not exceed one-fifth of the effective span. For simple spans, the effective span shall be taken as the span length. For continuous spans, the effective span shall be taken equal to the distance between points of permanent load contraflexure, or between a simple support and a point of permanent load contraflexure, as applicable. If the flange width exceeds one-fifth of the effective span, only a width equal to one-fifth of the effective span shall be considered effective in resisting flexure.

For multiple box sections in straight bridges satisfying the requirements of Article 6.11.2.3, the live-load flexural moment in each box may be determined in accordance with the applicable provisions of Article 4.6.2.2.2b. Shear due to St. Venant torsion and transverse bending and longitudinal warping stresses due to cross-section distortion may also be neglected for sections within these

C6.11.1.1

Stress analyses of actual box girder bridge designs were carried out to evaluate the effective width of a box flange using a series of folded plate equations (Goldberg and Leve, 1957). Bridges for which the span-to-flange width ratio varied from 5.65 to 35.3 were included in the study. The effective flange width as a ratio of the total flange width covered a range from 0.89 for the bridge with the smallest span-to-width ratio to 0.99 for the bridge with the largest span-to-width ratio. On this basis, it is reasonable to permit a box flange to be considered fully effective and subject to a uniform longitudinal stress, provided that its width does not exceed one-fifth of the span of the bridge. For extremely wide box flanges, a special investigation for shear lag effects may be required.

Although the results quoted above were obtained for simply-supported bridges, this criterion would apply equally to continuous bridges using the appropriate effective span defined in this Article for the section under consideration.

bridges that have fully effective box flanges. The section of an exterior member assumed to resist horizontal factored wind loading within these bridges may be taken as the bottom box flange acting as a web and 12 times the thickness of the web acting as flanges.

The provisions of Article 4.6.2.2.2b shall not apply to:

- Single box sections in straight or horizontally curved bridges,
- Multiple box sections in straight bridges not satisfying the requirements of Article 6.11.2.3, or
- Multiple box sections in horizontally curved bridges.

For these sections, and for sections that do not have fully effective box flanges, the effects of both flexural and St. Venant torsional shear shall be considered. The St. Venant torsional shear stress in box flanges due to the factored loads at the strength limit state shall not exceed the factored torsional shear resistance of the flange, F_{vr} , taken as:

$$F_{vr} = 0.75\phi_v \frac{F_{yf}}{\sqrt{3}} \quad (6.11.1.1-1)$$

where:

ϕ_v = resistance factor for shear specified in Article 6.5.4.2

In addition, transverse bending stresses due to cross-section distortion shall be considered for fatigue as specified in Article 6.11.5, and at the strength limit state. Transverse bending stresses due to the factored loads shall not exceed 20.0 ksi at the strength limit state. Longitudinal warping stresses due to cross-section distortion shall be considered for fatigue as specified in Article 6.11.5, but may be ignored at the strength limit state. Transverse bending and longitudinal warping stresses shall be determined by rational structural analysis in conjunction with the application of strength-of-materials principles. Transverse stiffeners attached to the webs or box flanges should be considered effective in resisting transverse bending.

The effective box-flange width should be used when calculating the flexural stresses in the section due to the factored loads. The full flange width should be used to calculate the nominal flexural resistance of the box flange.

Closed-box sections are capable of resisting torsion with limited distortion of the cross-section. Since distortion is generally limited by providing sufficient internal bracing in accordance with Article 6.7.4.3, torsion is resisted mainly by St. Venant torsional shear flow. The warping constant for closed-box sections is approximately equal to zero. Thus, warping shear and normal stresses due to warping torsion are typically quite small and are usually neglected.

Transverse bending stresses in box flanges and webs due to distortion of the box cross-section occur due to changes in direction of the shear flow vector. The transverse bending stiffness of the webs and flanges alone is not sufficient to retain the box shape so internal cross bracing is required. Longitudinal warping stresses due to cross-section distortion are also best controlled by internal cross bracing, as discussed further in Article C6.7.4.3.

Top flanges of tub girders subject to torsional loads need to be braced so that the section acts as a pseudo-box for noncomposite loads applied before the concrete deck hardens or is made composite. Top-flange bracing working with internal cross bracing retains the box shape and resists lateral force induced by inclined webs and torsion.

As discussed further in Article C6.11.2.3, for multiple box sections in straight bridges that conform to the restrictions specified in Article 6.11.2.3, the effects of St. Venant torsional shear and secondary distortional stresses may be neglected unless the box flange is very wide. The live-load distribution factor specified in Article 4.6.2.2.2b for straight multiple steel box sections may also be applied in the analysis of these bridges. Bridges not satisfying one or more of these restrictions must be investigated using one of the available methods of refined structural analysis, or other acceptable methods of approximate structural analysis as specified in Articles 4.4 or 4.6.2.2.4, since the specified live-load distribution factor does not apply to such bridges. The effects of St. Venant torsional shear and secondary distortional stresses are also more significant and must therefore be considered for sections in these bridges. Included in this category are all types of bridges containing single-box sections, and horizontally curved bridges containing multiple-box sections. Transverse bending stresses are of particular concern in boxes that may be subjected to large torques; e.g. single box sections, sharply curved boxes, and boxes resting on skewed supports. For other cases, the distortional stresses may be ignored if it can be demonstrated that the torques are of comparable magnitude to the torques for cases in which research has shown that these stresses are small enough to be neglected (Johnston and Mattock, 1967), e.g., a straight bridge of similar proportion satisfying the requirements of Article 6.11.2.3 or if the torques are deemed small enough in the judgment of the Owner and the Engineer. In such

cases, it is recommended that all web stiffeners be attached to both flanges to enhance fatigue performance.

In single-box sections in particular, significant torsional loads may occur during construction and under live loads. Live loads at the extreme of the deck can cause critical torsional loads without causing critical flexural moments. In the analysis, live load positioning should be done for flexure and torsion. The position of the bearings should be recognized in the analysis in sufficient completeness to permit direct computation of the reactions.

Where required, the St. Venant torsional shear and shear stress in web and flange elements can be calculated from the shear flow, which is determined as follows:

$$f = \frac{T}{2A_o} \quad (\text{C6.11.1.1-1})$$

where:

- A_o = enclosed area within the box section (in.²)
- f = shear flow (kip/in.)
- T = internal torque due to the factored loads (kip-in.)

For torques applied to the noncomposite section, A_o is to be computed for the noncomposite box section. As specified in Article 6.7.5.3, if top lateral bracing in a tub section is attached to the webs, A_o is to be reduced to reflect the actual location of the bracing. Because shear connectors are required along the entire length of box sections according to these provisions, the concrete deck can be considered effective in resisting torsion at any point along the span. Therefore, for torques applied to the composite section in regions of positive or negative flexure, A_o is to be computed for the composite section using the depth from the bottom flange to the mid-thickness of the concrete deck. The depth may be computed using a lower bound estimate of the actual thickness of the concrete haunch, or may be determined conservatively by neglecting the thickness of the haunch.

The torsion acting on the composite section also introduces horizontal shear in the concrete deck that should be considered when designing the reinforcing steel. Article C6.11.10 suggests a procedure for determining the torsional shear in the concrete deck for closed-box sections. For tub sections, the deck should be assumed to resist all the torsional shear acting on top of the composite box section.

Previous Specifications (AASHTO, 1993) limited the nominal St. Venant torsional shear resistance of box flanges to the shear yield stress, $F_{yf}/\sqrt{3}$. However, at this level of shear stress, there is a significant reduction in the nominal flexural resistance of the flange. Therefore, the nominal shear resistance is limited to $0.75 F_{yf}/\sqrt{3}$ in these provisions. Such a level of torsional shear stress is rarely, if ever, encountered in practical box-girder designs.

Where required, transverse or through-thickness bending stresses and stress ranges in the webs and flanges due to cross-section distortion can be determined using the beam-on-

elastic-foundation or BEF analogy presented by Wright and Abdel-Samad (1968). In this method, the internal diaphragms or cross-frames are analogous to intermediate supports in the BEF, and the resistance to distortion provided by the box cross-section is analogous to a continuous elastic foundation. The deflection of the BEF is analogous to the transverse bending stress. Transverse stiffeners should be considered effective with the web or box flange, as applicable, in computing the flexural rigidities of these elements. Sample calculations based on the BEF analogy are presented in Heins and Hall (1981) and in AASHTO (2003). The use of finite-element analysis to determine through-thickness bending stresses as part of the overall analysis of box sections is impractical due to the mesh refinement necessary for the accurate calculation of these stresses.

Longitudinal warping stresses due to cross-section distortion can also be determined using the BEF analogy. The warping stress is analogous to the moment in the BEF. The warping stresses are largest at the corners of the box where critical welded details are often located and should be considered for fatigue (Wright and Abdel-Samad, 1968). Tests have indicated that these warping stresses do not affect the ultimate strength of box girders of typical proportions.

Since top lateral bracing contributes to the flexural stiffness of tub sections, consideration should be given to including the longitudinal component of the top-flange bracing area when computing the section properties of the tub. Where used, longitudinal flange stiffeners should also be included in the section properties of the box or tub.

6.11.1.2—Bearings

Single or double bearings may be used at supports. Double bearings may be placed either inboard or outboard of the box section webs. If single bearings narrower than the bottom flange are used, they shall be aligned with the shear center of the box, and other supports shall have adequate bearings to ensure against overturning under any load combination. If tie-down bearings are used, the resulting force effects shall be considered in the design.

C6.11.1.2

The bearing arrangement dictates how torsion is resisted at supports and is especially critical for single box sections. When a single bearing arrangement is used, torque may be removed from multiple box sections through cross-frames or diaphragms between the boxes. Two bearings under each box provide a couple to resist the torque in each box. Double bearings can be placed between the box webs or outboard of the box. Placing bearings outboard of the box reduces overturning loads on the bearings and may eliminate uplift. For the case of double bearings, uplift may be especially critical when deck overhangs are large and heavy parapets or sound barriers are placed at the edges of the overhangs. Uplift should be checked ignoring the effect of the future wearing surface.

Integral cap beams of steel or concrete are often used with box sections in lieu of bearings.

6.11.1.3—Flange-to-Web Connections

Except as specified herein, the total effective thickness of flange-to-web welds shall not be less than the smaller of the web or flange thickness.

Where two or more intermediate internal diaphragms are provided in each span, fillet welds may be used for the flange-to-web connections. The weld size shall not be less than the size consistent with the requirements of

C6.11.1.3

If at least two intermediate internal cross-frames or diaphragms are not provided in each span, it is essential that the web-to-flange welds be of sufficient size to develop the smaller of the full web or flange section. Full-thickness welds should be provided in this case because of the possibility of secondary flexural stresses developing in the box section as a result of vibrations and/or distortions of the

Article 6.13.3.4. If fillet welds are used, they shall be placed on both sides of the connecting flange or web plate.

cross-section. Haaijer (1981) demonstrated that the transverse secondary distortional stress range at the web-to-flange welded joint is reduced more than 50 percent in such sections when one intermediate internal cross-frame per span is introduced and more than 80 percent when two intermediate internal cross-frames per span are introduced. Thus, when two or more intermediate internal cross-frames or diaphragms are provided in each span, fillet welds on both sides of the web designed according to the requirements of Article 6.13.3.4 may be assumed to be adequate.

It is essential that the welds be placed on both sides of the connecting flange or web plate whether full penetration or fillet welds are used. This will help minimize the possibility of a fatigue failure resulting from the transverse bending stresses.

6.11.1.4—Access and Drainage

Access holes in box sections should be located in the bottom flange in areas of low stress. The effect of access holes on the stresses in the flange should be investigated at all limit states to determine if reinforcement of the holes is required. At access holes in box flanges subject to compression, the nominal flexural resistance of the remaining flange on each side of the hole at the strength limit state shall be determined according to the provisions of Article 6.10.8.2.2, with λ_f taken as the projecting width of the flange on that side of the hole divided by the flange thickness, including any reinforcement. Provisions should be made for ventilation and drainage of the interior of box sections.

C6.11.1.4

At access holes in box flanges subject to compression, the nominal flexural resistance of the remaining flange on each side of the hole is determined using the local buckling resistance equations for I-girder compression flanges, with the flange slenderness based on the projecting width of the flange on that side of the hole.

Outside access holes should be large enough to provide easy access for inspection. Doors for exterior access holes should be hinged and provided with locks. All outside openings in box sections should be screened to exclude unauthorized persons, birds and vermin.

Consideration should be given to painting the interior of box sections a light color. Painting the interior of these sections is primarily done to facilitate inspections, and for tub sections, to prevent solar gain and to offer a minimum level of protection to the steel from the elements while the tub is temporarily open during construction. The paint quality need not match that normally used for exterior surfaces. A single-coat system should be sufficient in most cases, particularly when provisions are made for ventilation and drainage of the interior of the box.

6.11.2—Cross-Section Proportion Limits

6.11.2.1—Web Proportions

6.11.2.1.1—General

Webs may be inclined or vertical. The inclination of the web plates to a plane normal to the bottom flange should not exceed 1 to 4. For the case of inclined webs, the distance along the web shall be used for checking all design requirements. Webs attached to top flanges of tub sections shall be attached at mid-width of the flanges.

C6.11.2.1.1

Inclined webs are advantageous in reducing the width of the bottom flange.

Top flanges of tub sections with webs located at other than mid-width of the flange are not to be used because additional lateral flange bending effects are introduced that would require special investigation.

6.11.2.1.2—Webs without Longitudinal Stiffeners**C6.11.2.1.2**

Webs shall be proportioned such that:

Eq. 6.11.2.1.2-1 is discussed in Article C6.10.2.1.1.

$$\frac{D}{t_w} \leq 150 \quad (6.11.2.1.2-1)$$

6.11.2.1.3—Webs with Longitudinal Stiffeners**C6.11.2.1.3**

Webs shall be proportioned such that:

Eq. 6.11.2.1.3-1 is discussed in Article C6.10.2.1.2.

$$\frac{D}{t_w} \leq 300 \quad (6.11.2.1.3-1)$$

6.11.2.2—Flange Proportions**C6.11.2.2**

Top flanges of tub sections subject to compression or tension shall be proportioned such that:

Eqs. 6.11.2.2-1 through 6.11.2.2-3 apply to flanges of I-sections and are also applied to a single top flange of a tub section. Eqs. 6.11.2.2-1 through 6.11.2.2-3 are discussed in Article C6.10.2.2.

$$\frac{b_f}{2t_f} \leq 12.0, \quad (6.11.2.2-1)$$

$$b_f \geq D/6, \quad (6.11.2.2-2)$$

and:

Box flanges should extend at least one inch beyond the outside of each web to allow for welding of the webs to the flange. The Engineer should consider providing an option on the design plans for the fabricator to increase this distance, if necessary, to provide for greater welding access.

$$t_f \geq 1.1t_w \quad (6.11.2.2-3)$$

6.11.2.3—Special Restrictions on Use of Live Load Distribution Factor for Multiple Box Sections**C6.11.2.3**

Cross-sections of straight bridges consisting of two or more single-cell box sections, for which the live load flexural moment in each box is determined in accordance with the applicable provisions of Article 4.6.2.2.2b, shall satisfy the geometric restrictions specified herein. In addition, the bearing lines shall not be skewed.

Restrictions specified in this Article for straight bridges utilizing multiple box sections are necessary in order to employ the lateral live-load distribution factor given in Article 4.6.2.2.2b for straight multiple steel box sections. The development of this distribution factor is based on an extensive study of bridges that conform to these limitations (Johnston and Mattock, 1967). The study assumed an uncracked stiffness for the composite section along the entire span.

The distance center-to-center of flanges of adjacent boxes, a , taken at the midspan, shall neither be greater than 120 percent nor less than 80 percent of the distance center-to-center of the flanges of each adjacent box, w , as illustrated in Figure 6.11.2.3-1. In addition to the midspan requirement, where nonparallel box sections are used, the distance center-to-center of adjacent flanges at supports shall neither be greater than 135 percent nor less than 65 percent of the distance center-to-center of the flanges of each adjacent box. The distance center-to-center of flanges of each individual box shall be the same.

Further, it was determined that when these restrictions are satisfied, shear due to St. Venant torsion and secondary distortional bending stress effects may be neglected if the width of the box flange does not exceed one-fifth of the effective span defined in Article 6.11.1.1. It was found from an analytical study of bridges of this type that when such bridges were loaded so as to produce maximum moment in a particular girder, and hence maximum compression in the flange plate near an intermediate support, the amount of twist in that girder was negligible. It therefore appears reasonable that, for bridges conforming to the restrictions set forth in this Article and with fully effective box flanges, shear due to torsion need not be considered in the design of box flanges for maximum compression or tension loads.

The inclination of the web plates to a plane normal to the bottom flange shall not exceed 1 to 4.

The cantilever overhang of the concrete deck, including curb and parapet, shall not be greater than either 60 percent of the average distance between the centers of the top steel flanges of adjacent box sections, a , or 6.0 ft.

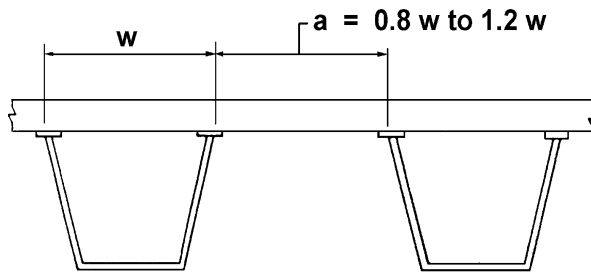

Figure 6.11.2.3-1—Center-to-Center Flange Distance

In the case of bridges with support skew, additional torsional effects occur in the box sections and the lateral distribution of loads is also affected. Although the bridge may satisfy the cross-section restrictions of this Article, these effects are not comprehended by the lateral distribution factor specified in Article 4.6.2.2.2b. Therefore, in these cases, a more rigorous analysis of stresses is necessary using one of the available methods of refined structural analysis. For straight portions of bridges that satisfy these restrictions, but that also contain horizontally curved segments, a refined analysis is also recommended. Although not required, refined structural analysis methods may also be used for bridges satisfying the restrictions of this Article, if desired.

Some limitations are placed on the variation of the distance a with respect to the distance w shown in Figure 6.11.2.3-1 when the distribution factor is used because the studies on which the live load distribution provisions are based were made on bridges in which a and w were equal. The limitations given for nonparallel box sections will allow some flexibility of layout in design while generally maintaining the validity of the provisions. For cases with nonparallel box sections where the live load distribution factor is employed, refer to the provisions of Article 4.6.2.2.2b.

6.11.3—Constructibility

6.11.3.1—General

Except as specified herein, the provisions of Article 6.10.3 shall apply.

The individual box section geometry shall be maintained throughout all stages of construction. The need for temporary or permanent intermediate internal diaphragms or cross-frames, external diaphragms or cross-frames, top lateral bracing, or other means shall be investigated to ensure that deformations of the box section are controlled.

6.11.3.2—Flexure

For critical stages of construction, the provisions of Articles 6.10.3.2.1 through 6.10.3.2.3 shall be applied only to the top flanges of tub sections. The unbraced length should be taken as the distance between interior cross-frames or diaphragms. The provisions of Article A6.3.3 shall not be applied in determining the lateral torsional buckling resistance of top flanges of tub sections with compact or noncompact webs.

For critical stages of construction, noncomposite box flanges in compression shall satisfy the following requirements:

C6.11.3.1

The Engineer should consider possible eccentric loads that may occur during construction. These may include uneven placement of concrete and equipment. Temporary cross-frames or diaphragms that are not part of the original design should be removed because the structural behavior of the box section, including load distribution, may be significantly affected if these members are left in place.

Additional information on construction of composite box sections may be found in NSBA (1996) and United States Steel (1978).

For painted box sections, the Engineer should consider making an allowance for the weight of the paint. For typical structures, three percent of the steel weight is a reasonable allowance.

C6.11.3.2

Although the equations of Articles 6.10.3.2.1 through 6.10.3.2.3 apply to flanges of I-sections, they may also safely be applied to a single top flange of a tub section. The provisions of Article 6.10.1.6 also apply when these equations are used.

Top lateral bracing attached to the flanges at points where only struts exist between the flanges may be considered as brace points at the discretion of the Engineer.

For straight girders, lateral bending in discretely braced top flanges of tub sections, before the concrete deck has hardened or is made composite, is caused by wind and by

$$f_{bu} \leq \phi_f F_{nc} \quad (6.11.3.2-1)$$

and:

$$f_{bu} \leq \phi_f F_{crw} \quad (6.11.3.2-2)$$

where:

- ϕ_f = resistance factor for flexure specified in Article 6.5.4.2
 f_{bu} = longitudinal flange stress due to the factored loads at the section under consideration calculated without consideration of longitudinal warping (ksi)
 F_{crw} = nominal bend-buckling resistance for webs specified in Article 6.10.1.9 (ksi)
 F_{nc} = nominal flexural resistance of box flanges in compression determined as specified in Article 6.11.8.2 (ksi). In computing F_{nc} for constructibility, the web load-shedding factor, R_b , shall be taken as 1.0.

For sections with compact or noncompact webs, Eq. 6.11.3.2-2 shall not be checked.

For critical stages of construction, noncomposite box flanges in tension and continuously braced box flanges in tension or compression shall satisfy the following requirement:

$$f_{bu} \leq \phi_f R_h F_{yf} \Delta \quad (6.11.3.2-3)$$

in which:

$$\Delta = \sqrt{1 - 3 \left(\frac{f_v}{F_{yf}} \right)^2} \quad (6.11.3.2-4)$$

f_v = St. Venant torsional shear stress in the flange due to the factored loads at the section under consideration (ksi)

$$= \frac{T}{2A_o t_f} \quad (6.11.3.2-5)$$

where:

- A_o = enclosed area within the box section (in.²)
 R_h = hybrid factor determined as specified in Article 6.10.1.10.1
 T = internal torque due to the factored loads (kip-in.)

For loads applied to a composite box flange before the concrete has hardened or is made composite, the flange shall be designed as a noncomposite box flange. The maximum vertical deflection of the noncomposite box

torsion from various origins. The equations of Articles 6.10.3.2.1 and 6.10.3.2.2 allow the Engineer to directly consider the effects of the flange lateral bending, if deemed significant. When the flange lateral bending effects are judged to be insignificant or incidental, the lateral bending term, f_t , is simply set equal to zero in these equations. The format of the equations then reduces simply to the more conventional format for checking the flanges for the limit states of yielding, lateral torsional buckling or local buckling, as applicable, in the absence of flange lateral bending. For horizontally curved girders, flange lateral bending effects due to curvature must always be considered during construction. For loads applied during construction once the top flanges are continuously braced, the provisions of Article 6.10.3.2.3 apply. A distinction is made between discretely and continuously braced flanges in Article 6.10.3.2 because for a continuously braced flange, lateral flange bending need not be considered. Article C6.10.1.6 states the conditions for which top flanges may be considered continuously braced. St. Venant torsional shears are also typically neglected in continuously braced top flanges of tub sections. In checking the requirements of Articles 6.10.3.2.1 through 6.10.3.2.3 for a single top flange of a tub, it is recommended that the checks be made for half of the tub section.

In checking Eq. 6.10.3.2.1-2 for I-sections in straight bridges with compact or noncompact webs, Article A6.3.3 optionally permits the lateral torsional buckling resistance of the compression flange to be determined including the beneficial contribution of the St. Venant torsional constant J . The use of these provisions is conservatively prohibited in checking top flanges of tub sections with compact or noncompact webs. The compact, noncompact and slender web definitions are discussed in Article C6.10.6.2.3. For making these checks with the section in its noncomposite condition, the categorization of the web is to be based on the properties of the noncomposite section.

One potential source of flange lateral bending due to torsion is the effect of eccentric concrete deck overhang loads acting on cantilever forming brackets placed along exterior tub sections. In lieu of a more refined analysis, the maximum flange lateral bending moments in the outermost top flange of a tub due to these eccentric loadings may be estimated using either Eq. C6.10.3.4-2 or C6.10.3.4-3 depending on how the lateral load is assumed applied to the flange.

In box sections with inclined webs, the change in the horizontal component of the web dead load shear plus the change in the St. Venant torsional dead load shear per unit length along the member acts as a uniformly distributed transverse load on the girder flanges. Additional intermediate internal cross-frames, diaphragms or struts may be required to reduce the lateral bending in discretely braced top flanges of tub sections resulting from this transverse load. This may be particularly true for cases where the inclination of the web plates to a plane normal to the bottom flange is permitted to exceed 1 to 4, and/or where the unbraced length of the top flanges exceeds 30 ft.

flange due to the unfactored permanent loads, including the self-weight of the flange plus the unfactored construction loads, shall not exceed 1/360 times the transverse span between webs. The through-thickness bending stress in the noncomposite box flange due to the factored permanent loads and factored construction loads shall not exceed 20.0 ksi. The weight of wet concrete and other temporary or permanent loads placed on a noncomposite box flange may be considered by assuming the box flange acts as a simple beam spanning between webs. Stiffening of the flange may be used where required to control flange deflection and stresses due to loads applied before the concrete deck has hardened or is made composite.

Otherwise, this transverse load can typically be ignored. The maximum lateral flange bending moments due to this transverse load can be estimated using Eq. C6.10.3.4-2 in lieu of a more refined analysis, where F_t is taken as the magnitude of the factored uniformly distributed transverse load. The entire transverse load should be assumed applied to the top flanges (Fan and Helwig, 1999). The cross-frame or strut can be assumed to carry the entire transverse load within the panel under consideration.

Another potential source of flange lateral bending is due to the forces that develop in Warren-type single-diagonal top lateral bracing systems due to flexure of the tub section. Refer to Article C6.7.5.3 for further discussion regarding this topic.

In cases where a full-length lateral bracing system is not employed within a tub section, as discussed further in Article C6.7.5.3, the minimum width of the top flanges within each field piece should satisfy the guideline given by Eq. C6.10.3.4-1, in conjunction with the flange proportion limits specified in Article 6.11.2.2. In this case, L in Eq. C6.10.3.4-1 is to be taken as the larger of the distances along the field piece between panels of lateral bracing or between a panel of lateral bracing and the end of the piece. For cases where a full-length lateral bracing system is employed, Eq. C6.10.3.4-1 need not be considered for top flanges of tub sections.

For noncomposite box flanges in compression, local buckling of the flange during critical stages of construction is checked according to Eq. 6.11.3.2-1. Flange lateral bending and lateral torsional buckling are not a consideration for box flanges.

Eq. 6.11.3.2-2 ensures that theoretical web bend-buckling will not occur during construction at sections where noncomposite box flanges are subject to compression. Eq. 6.10.3.2.1-3 serves a similar function at sections where top flanges of tub sections are subject to compression. For box sections with inclined webs, D_c should be taken as depth of the web in compression measured along the slope in determining the web bend-buckling resistance, F_{crws} , in either case. Because the flange stress is limited to the web bend-buckling stress, the R_b factor is always to be taken equal to 1.0 in computing the nominal flexural resistance of the compression flange for constructibility. Options to consider should the flange not satisfy Eq. 6.11.3.2-2 or Eq. 6.10.3.2.1-3, as applicable, for the construction condition are discussed in Article C6.10.3.2.1. For sections with compact or noncompact webs, web bend-buckling is not a consideration, and therefore, need not be checked for these sections.

For noncomposite box flanges in tension, or for continuously braced box flanges in tension or compression, the von Mises yield criterion (Boresi et al., 1978) is used in Eq. 6.11.3.2-3 to consider the effect of the torsional shear.

Longitudinal warping stresses due to cross-section distortion typically need not be considered in checking Eqs. 6.11.3.2-1 and 6.11.3.2-3, but are required to be

6.11.3.3—Shear

When checking the shear requirement specified in Article 6.10.3.3, the provisions of Article 6.11.9 shall also apply, as applicable.

6.11.4—Service Limit State

Except as specified herein, the provisions of Article 6.10.4 shall apply.

The f_t term in Eq. 6.10.4.2.2-2 shall be taken equal to zero. Eq. 6.10.4.2.2-3 shall not apply. Except for sections in positive flexure in which the web satisfies the requirement of Article 6.11.2.1.2, all sections shall satisfy Eq. 6.10.4.2.2-4.

Redistribution of the negative moment due to the Service II loads at interior-pier sections in continuous-span flexural members using the procedures specified in Appendix B6 shall not apply.

considered when checking slip of the connections in bolted flange splices for the construction condition as specified in Article 6.13.6.1.4c.

In closed-box sections, noncomposite box flanges on top of the box receive the weight of wet concrete and other loads during construction before the deck hardens or is made composite. Transverse and/or longitudinal stiffening of the box flange may be required to control box-flange deflection and stresses.

C6.11.4

Article 6.10.4.1 refers to the provisions of Article 2.5.2.6, which contain optional live-load deflection criteria and criteria for span-to-depth ratios. In the absence of depth restrictions, the span-to-depth ratios listed for I-sections can be used to establish a reasonable minimum web depth for the design. However, because of the inherent torsional stiffness of a box section, the optimum depth for a box section will typically be slightly less than the optimum depth for an I-section of the same span. Because the size of box flanges can typically be varied less over the bridge length, establishing a sound optimum depth for box sections is especially important. Boxes that are overly shallow may be subject to larger torsional shears.

Under the load combinations specified in Table 3.4.1-1, Eqs. 6.10.4.2.2-1 and 6.10.4.2.2-2 need only be checked for compact sections in positive flexure. For sections in negative flexure and noncompact sections in positive flexure, these equations do not control and need not be checked. However, Eq. 6.10.4.2.2-4 must still be checked for these sections where applicable.

Flange lateral bending is not a consideration for box flanges, and therefore, need not be considered when checking Eq. 6.10.4.2.2-2. Flange lateral bending is not considered in Eq. 6.10.4.2.2-1 because the top flanges are continuously braced at the service limit state. Longitudinal warping stresses due to cross-section distortion need not be considered in checking the equations of Article 6.10.4.2.2, but are required to be considered when checking slip of the connections in bolted flange splices at the service limit state as specified in Article 6.13.6.1.4c. St. Venant torsional shear stresses are also not considered in checking the equations of Article 6.10.4.2.2 for box flanges. The effects of longitudinal warping stresses and torsional shear on the overall permanent deflections at the service limit state are considered to be relatively insignificant.

For box sections with inclined webs, D_c should be taken as the depth of the web in compression measured along the slope in determining the web bend-buckling resistance, F_{crw} , for checking Eq. 6.10.4.2.2-4, where applicable.

6.11.5—Fatigue and Fracture Limit State

Except as specified herein, the provisions of Article 6.10.5 shall apply.

For fatigue in shear connectors, the provisions of Article 6.11.10 shall also apply, as applicable. The provisions for fatigue in shear connectors specified in Article 6.10.10.3 shall not apply.

When checking the shear requirement specified in Article 6.10.5.3, the provisions of Article 6.11.9 shall also apply, as applicable.

Longitudinal warping stresses and transverse bending stresses due to cross-section distortion shall be considered for:

- Single box sections in straight or horizontally curved bridges,
- Multiple box sections in straight bridges not satisfying the requirements of Article 6.11.2.3,
- Multiple box sections in horizontally curved bridges, or
- Any single or multiple box section with a box flange that is not fully effective according to the provisions of Article 6.11.1.1.

The stress range due to longitudinal warping shall be considered in checking the fatigue resistance of the base metal at all details on the box section according to the provisions specified in Article 6.6.1. The transverse bending stress range shall be considered separately in evaluating the fatigue resistance of the base metal adjacent to flange-to-web fillet welds and adjacent to the termination of fillet welds connecting transverse elements to webs and box flanges. In determining the longitudinal warping and transverse bending stress ranges, one cycle of stress shall be defined as 75 percent of the stress range determined by the passage of the factored fatigue load in two different critical transverse positions. In no case shall the stress range calculated in this manner be less than the calculated stress range due to the passage of the factored fatigue load in only one lane. The need for a bottom transverse member within the internal cross-frames to resist the transverse bending stress range in the bottom box flange at the termination of fillet welds connecting cross-frame connection plates to the flange shall be investigated. Transverse cross-frame members next to box flanges shall be attached to the box flange unless longitudinal flange stiffeners are used, in which case the transverse members shall be attached to the longitudinal stiffeners by bolting. The moment of inertia of these transverse cross-frame members shall not be less than the moment of inertia of the largest connection plate

The applicability of the optional provisions of Appendix B6 to box sections has not been demonstrated. Therefore, these provisions may not be used in the design of box sections.

C6.11.5

When a box section is subjected to a torsional load, its cross-section distorts and is restored at diaphragms or cross-frames. This distortion gives rise to secondary bending stresses. A torsional loading in the opposite direction produces a reversal of these distortional secondary bending stresses. In certain cases, as defined herein, these distortional stresses are to be considered when checking fatigue. Situations for which these stresses are of particular concern and for which these stresses may potentially be ignored are discussed in Article C6.11.1.1.

Transverse bending and longitudinal warping stress ranges due to cross-section distortion can be determined using the BEF analogy, as discussed in Article C6.11.1.1. Longitudinal warping stresses are considered additive to the longitudinal major-axis bending stresses.

The largest distortional stress range is usually caused by positioning the live load on one side and then on the opposite side of a box. To cause one cycle of the stress range so computed requires two vehicles to traverse the bridge in separate transverse positions, with one vehicle leading the other. To account for the unlikely event of this occurring over millions of cycles, the provisions permit application of a factor of 0.75 to the computed range of distortionally-induced stresses, except when the maximum stress range is caused by loading of only one lane. This 0.75 factor is distinct from the load factor specified for the applicable fatigue load combination in Table 3.4.1-1, i.e., when applicable, both factors may be applied simultaneously. There is no provision to account for the need for two trucks to cause a single cycle of stress in this case. For cases where the nominal fatigue resistance is calculated based on a finite life, the Engineer may wish to consider a reduction in the number of cycles since two cycles are required to cause a single cycle of stress.

The most critical case for transverse bending is likely to be the base metal at the termination of fillet welds connecting transverse elements to webs and box flanges. A stress concentration occurs at the termination of these welds as a result of the transverse bending. The fatigue resistance of this detail when subject to transverse bending is not currently quantified, but is anticipated to be perhaps as low as Category E.

Should this situation be found critical in the web at transverse web stiffeners not serving as connection plates, the transverse bending stress range may be reduced by welding the stiffeners to the flanges. Attaching transverse stiffeners to the flanges reduces the sharp through-thickness bending stresses within the unstiffened portions of the web at the termination of the stiffener-to-web welds, which is usually the most critical region for this check. Cross-frame connection plates already are required to be

for the internal cross-frame under consideration taken about the edge in contact with the web.

For single box sections, box flanges in tension shall be considered fracture-critical, unless analysis shows that the section can support the full dead and an appropriate portion of the live load after sustaining a hypothetical complete fracture of the flange and webs at any point.

Unless adequate strength and stability of a damaged structure can be verified by refined analysis, in cross-sections comprised of two box sections, only the bottom flanges in the positive moment regions should be designated as fracture-critical. Where cross-sections contain more than two box girder sections, none of the components of the box sections should be considered fracture-critical.

attached to the flanges according to the provisions of Article 6.6.1.3.1 for this reason.

Should it become necessary to reduce the transverse bending stress range in the box flange adjacent to the cross-frame connection plate welds to the flange, the provision of transverse cross-frame members across the bottom of the box or tub as part of the internal cross-bracing significantly reduces the transverse bending stress range at the welds and ensures that the cross-section shape is retained. Closer spacing of cross-frames also leads to lower transverse bending stresses. Where bottom transverse cross-frame members are provided, they are to be attached to the box flange or to the longitudinal flange stiffeners, as applicable. For closed-box sections, the top transverse cross-frame members should be similarly attached. Where transverse bracing members are welded directly to the box flange, the stress range due to transverse bending should also be considered in checking the fatigue resistance of the base metal adjacent to the termination of these welds. Where transverse bracing members are connected to longitudinal flange stiffeners, the box flange may be considered stiffened when computing the transverse bending stresses. In such cases, the transverse connection plates must still be attached to both flanges as specified in Article 6.6.1.3.1.

Load-induced fatigue is usually not critical for top lateral bracing in tub sections since the concrete deck is much stiffer and resists more of the load than does the bracing. Since the deck resists the majority of the torsional shear in these cases, it is advisable to check the reinforcement in the deck for the additional horizontal shear. Severely skewed supports may cause critical horizontal deck shear.

It is advisable to connect the lateral bracing to the top flanges to eliminate a load path through the web. Although removable deck forms are problematic in tub girders, they are sometimes required by the Owner. In such cases, it may be necessary to lower the lateral bracing by attaching it to the box webs. In these cases, connections to the webs must be made according to the requirements of Article 6.6.1.3.2 to prevent potential problems resulting from fatigue. An adequate load path, with fatigue considered, must be provided between the bracing-to-web connections and the top flanges. Connections of the lateral bracing to the web can be avoided by using metal stay-in-place deck forms.

Fatigue of the base metal at the net section of access holes should be considered. The fatigue resistance at the net section of large access holes is not currently specified; however, base metal at the net section of open bolt holes has been shown to satisfy Category D (Brown et al., 2007). This assumes a stress concentration, or ratio of the elastic tensile stress adjacent to the hole to the average stress on the net area, of 3.0. A less severe fatigue category might be considered if the proper stress concentration at the edges of the access hole is evaluated.

Refer to Article C6.6.2 for further discussion regarding the use of refined analyses to demonstrate that part of a structure is not fracture-critical.

There may be exceptions where box flanges of single-box sections subject to tension need not be considered fracture critical. For example, continuously braced top flanges in regions of negative flexure where there is adequate deck reinforcing to act as a top flange. In such cases, adequate shear connection must also be provided.

6.11.6—Strength Limit State

6.11.6.1—General

For the purposes of this Article, the applicable Strength load combinations specified in Table 3.4.1-1 shall apply.

6.11.6.2—Flexure

6.11.6.2.1—General

If there are holes in the tension flange at the section under consideration, the tension flange shall satisfy the requirement specified in Article 6.10.1.8.

6.11.6.2.2—Sections in Positive Flexure

Sections in horizontally curved steel girder bridges shall be considered as noncompact sections and shall satisfy the requirements of Article 6.11.7.2.

Sections in straight bridges that satisfy the following requirements shall qualify as compact sections:

- The specified minimum yield strengths of the flanges and web do not exceed 70.0 ksi,
- The web satisfies the requirement of Article 6.11.2.1.2,
- The section is part of a bridge that satisfies the requirements of Article 6.11.2.3,

C6.11.6.1

At the strength limit state, Article 6.11.6 directs the Engineer to the appropriate Articles for the design of box sections in regions of positive or negative flexure.

C6.11.6.2.1

The requirement of Article 6.10.1.8 is intended to prevent net section fracture at a cross-section with holes in the tension flange subject to either positive or negative flexure. Where an access hole is provided in the tension flange, the hole should be deducted in determining the gross section for checking this requirement, as specified in Article 6.8.1.

A continuously braced flange in compression is assumed not to be subject to local or lateral torsional buckling, as applicable. The rationale for excluding these limit state checks is discussed in Article C6.10.3.2.3.

These provisions assume low or zero levels of axial force in the member. At sections that are also subject to a concentrically-applied axial force, P_u , due to the factored loads in excess of ten percent of the factored axial resistance of the member, P_r , at the strength limit state, the section should instead be checked according to the provisions of Article 6.8.2.3 or 6.9.2.2, as applicable. According to the equations given in these Articles, when P_u is ten percent of P_r , the flexural resistance of the member is reduced by five percent. Below this level, it is reasonable to ignore the effect of the axial force in the design of the member.

C6.11.6.2.2

The nominal flexural resistance of sections in positive flexure within straight bridges satisfying the requirements of Article 6.11.2.3 and that also satisfy specific steel grade, web slenderness, effective flange width and ductility requirements is permitted to exceed the moment at first yield according to the provisions of Article 6.10.7. The nominal flexural resistance of these sections, termed compact sections, is therefore more appropriately expressed in terms of moment. For sections in positive flexure in straight bridges not satisfying one or more of these requirements, or for composite sections in positive flexure in horizontally curved bridges, termed noncompact sections, the nominal flexural resistance is not permitted to exceed the moment at

- The box flange is fully effective as specified in Article 6.11.1.1,

and:

- The section satisfies the web slenderness limit:

$$\frac{2D_{cp}}{t_w} \leq 3.76 \sqrt{\frac{E}{F_{yc}}} \quad (6.11.6.2.2-1)$$

where:

D_{cp} = depth of the web in compression at the plastic moment determined as specified in Article D6.3.2 (in.)

Compact sections shall satisfy the requirements of Article 6.11.7.1. Otherwise, the section shall be considered noncompact and shall satisfy the requirements of Article 6.11.7.2.

Compact and noncompact sections shall satisfy the ductility requirement specified in Article 6.10.7.3.

6.11.6.2.3—Sections in Negative Flexure

The provisions of Article 6.11.8 shall apply. The provisions of Appendix A6 shall not apply. Redistribution of the negative moment due to the factored loads at interior-pier sections in continuous-span flexural members using the procedures specified in Appendix B6 shall not apply.

6.11.6.3—Shear

The provisions of Article 6.11.9 shall apply.

6.11.6.4—Shear Connectors

The provisions of Article 6.10.10.4 shall apply. The provisions of Article 6.11.10 shall also apply, as applicable.

first yield. The nominal flexural resistance in these cases is therefore more appropriately expressed in terms of the elastically computed flange stress.

For reasons discussed in Article C6.10.6.2.2, composite sections in positive flexure in straight bridges with flange yield strengths greater than 70.0 ksi or with webs that do not satisfy Article 6.11.2.1.2 or Eq. 6.11.6.2.2-1 are to be designed at the strength limit state as noncompact sections as specified in Article 6.11.7.2. Furthermore, if the section is not part of a straight bridge that satisfies the restrictions specified in Article 6.11.2.3, or is part of a horizontally curved bridge, or if the box flange is not fully effective as defined in Article 6.11.1.1, the section must be designed as a noncompact section. The ability of such sections to develop a nominal flexural resistance greater than the moment at first yield in the presence of potentially significant St. Venant torsional shear and cross-sectional distortion stresses has not been demonstrated.

Compact sections in positive flexure must satisfy the provisions of Article 6.10.7.3 to ensure a ductile mode of failure. Noncompact sections must also satisfy the ductility requirement specified in Article 6.10.7.3 to ensure a ductile failure. Satisfaction of this requirement ensures an adequate margin of safety against premature crushing of the concrete deck for sections utilizing up to 100-ksi steels and/or for sections utilized in shored construction. This requirement is also a key limit in allowing web bend-buckling to be disregarded in the design of composite sections in positive flexure when the web also satisfies Article 6.11.2.1.2, as discussed in Article C6.10.1.9.1.

C6.11.6.2.3

For sections in negative flexure, the provisions of Article 6.11.8 limit the nominal flexural resistance to be less than or equal to the moment at first yield for all types of box girder bridges. As a result, the nominal flexural resistance for these sections is conveniently expressed in terms of the elastically computed flange stress.

The applicability of the optional provisions of Appendices A6 and B6 to box sections has not been demonstrated. Therefore, these provisions may not be used in the design of box sections.

6.11.7—Flexural Resistance—Sections in Positive Flexure

6.11.7.1—Compact Sections

6.11.7.1.1—General

At the strength limit state, the section shall satisfy:

$$M_u \leq \phi_f M_n \quad (6.11.7.1.1-1)$$

where:

- ϕ_f = resistance factor for flexure specified in Article 6.5.4.2
- M_n = nominal flexural resistance of the section determined as specified in Article 6.11.7.1.2 (kip-in.)
- M_u = bending moment about the major-axis of the cross-section due to the factored loads at the section under consideration (kip-in.)

6.11.7.1.2—Nominal Flexural Resistance

The nominal flexural resistance of the section shall be taken as specified in Article 6.10.7.1.2, except that for continuous spans, the nominal flexural resistance shall always be subject to the limitation of Eq. 6.10.7.1.2-3.

6.11.7.2—Noncompact Sections

6.11.7.2.1—General

At the strength limit state, compression flanges shall satisfy:

$$f_{bu} \leq \phi_f F_{nc} \quad (6.11.7.2.1-1)$$

where:

- ϕ_f = resistance factor for flexure specified in Article 6.5.4.2
- f_{bu} = longitudinal flange stress at the section under consideration calculated without consideration of flange lateral bending or longitudinal warping, as applicable (ksi)
- F_{nc} = nominal flexural resistance of the compression flange determined as specified in Article 6.11.7.2.2 (ksi)

The tension flange shall satisfy:

C6.11.7.1.1

For composite sections in positive flexure, lateral bending does not need to be considered in the compression flanges of tub sections at the strength limit state because the flanges are continuously supported by the concrete deck. Flange lateral bending is also not a consideration for box flanges.

C6.11.7.1.2

The equations of Article 6.10.7.1.2 are discussed in detail in Article C6.10.7.1.2.

For box sections, Eq. 6.10.7.1.2-3 is to always be used for determining the limiting nominal flexural resistance of compact sections in positive flexure in straight continuous spans. The provisions of Appendix B6, which ensure that interior-pier sections will have sufficient ductility and robustness such that the redistribution of moments caused by partial yielding within the positive flexural regions is inconsequential, are not presently applicable to box sections.

C6.11.7.2.1

For noncompact sections, the compression flange must satisfy Eq. 6.11.7.2.1-1 and the tension flange must satisfy Eq. 6.11.7.2.1-2 at the strength limit state. For composite sections in positive flexure, lateral bending does not need to be considered in the compression flanges at the strength limit state because the flanges are continuously supported by the concrete deck. Lateral bending is also not a consideration for the tension flange, which is always a box flange in this case.

For noncompact sections, the longitudinal stress in the concrete deck is limited to $0.6f'_c$ to ensure linear behavior of the concrete, which is assumed in the calculation of the steel flange stresses. This condition is unlikely to govern except in cases involving: (1) shored construction, or unshored construction where the noncomposite steel dead load stresses are low, combined with (2) geometries causing the neutral axis of the short-term and long-term composite section to be significantly below the bottom of the concrete deck.

$$f_{bu} \leq \phi_f F_{nt} \quad (6.11.7.2.1-2)$$

where:

F_{nt} = nominal flexural resistance of the tension flange determined as specified in Article 6.11.7.2.2 (ksi)

The maximum longitudinal compressive stress in the concrete deck at the strength limit state, determined as specified in Article 6.10.1.1.1d, shall not exceed $0.6f'_c$.

6.11.7.2.2—Nominal Flexural Resistance

The nominal flexural resistance of the compression flanges of tub sections shall be taken as:

$$F_{nc} = R_b R_h F_{yc} \quad (6.11.7.2.2-1)$$

where:

R_b = web load-shedding factor determined as specified in Article 6.10.1.10.2

R_h = hybrid factor determined as specified in Article 6.10.1.10.1

The nominal flexural resistance of the compression flange of closed-box sections shall be taken as:

$$F_{nc} = R_b R_h F_{yc} \Delta \quad (6.11.7.2.2-2)$$

in which:

$$\Delta = \sqrt{1 - 3 \left(\frac{f_v}{F_{yc}} \right)^2} \quad (6.11.7.2.2-3)$$

f_v = St. Venant torsional shear stress in the flange due to the factored loads at the section under consideration (ksi)

$$= \frac{T}{2A_o t_{fc}} \quad (6.11.7.2.2-4)$$

where:

A_o = enclosed area within the box section (in.²)

T = internal torque due to the factored loads (kip-in.)

The nominal flexural resistance of the tension flange of closed-box and tub sections shall be taken as:

$$F_{nt} = R_h F_{yt} \Delta \quad (6.11.7.2.2-5)$$

in which:

C6.11.7.2.2

The nominal flexural resistance of noncompact sections in positive flexure is limited to the moment at first yield. Thus, the nominal flexural resistance is expressed simply in terms of the flange stress. For noncompact sections, the elastically computed stress in each flange due to the factored loads, determined in accordance with Article 6.10.1.1.1a, is compared with the yield stress of the flange times the appropriate flange-stress reduction factors.

For box flanges, the effect of the St. Venant torsional shear stress in the flange must also be considered where necessary. The computation of the flange torsional shear stress from Eq. 6.11.7.2.2-4 or 6.11.7.2.2-7, as applicable, due to torques applied separately to the noncomposite and composite sections is discussed in Article C6.11.1.1.

$$\Delta = \sqrt{1 - 3 \left(\frac{f_v}{F_{yt}} \right)^2} \quad (6.11.7.2.2-6)$$

f_v = St. Venant torsional shear stress in the flange due to the factored loads at the section under consideration (ksi)

$$= \frac{T}{2A_o t_{ft}} \quad (6.11.7.2.2-7)$$

6.11.8—Flexural Resistance—Sections in Negative Flexure

6.11.8.1—General

6.11.8.1.1—Box Flanges in Compression

C6.11.8.1.1

At the strength limit state, the following requirement shall be satisfied:

$$f_{bu} \leq \phi_f F_{nc} \quad (6.11.8.1.1-1)$$

where:

- ϕ_f = resistance factor for flexure specified in Article 6.5.4.2
- f_{bu} = longitudinal flange stress due to the factored loads at the section under consideration calculated without consideration of longitudinal warping (ksi)
- F_{nc} = nominal flexural resistance of the flange determined as specified in Article 6.11.8.2 (ksi)

Eq. 6.11.8.1.1-1 ensures that box flanges in compression have sufficient strength with respect to flange local buckling. Flange lateral bending and lateral torsional buckling are not a consideration for box flanges.

In general, bottom box flanges at interior-pier sections are subjected to biaxial stresses due to major-axis bending of the box section and major-axis bending of the internal diaphragm over the bearing sole plate. The flange is also subject to shear stresses due to the internal diaphragm vertical shear, and in cases where it must be considered, the St. Venant torsional shear. Bending of the internal diaphragm over the bearing sole plate can be particularly significant for boxes supported on single bearings. For cases where the shear stresses and/or bending of the internal diaphragm are deemed significant, the following equation may be used to check this combined stress state in the box flange at the strength limit state:

$$\sqrt{f_{bu}^2 - f_{bu} f_{by} + f_{by}^2 + 3(f_d + f_v)^2} \leq \phi_f R_b R_h F_{yc} \quad (C6.11.8.1.1-1)$$

where:

- f_{by} = stress in the flange due to the factored loads caused by major-axis bending of the internal diaphragm over the bearing sole plate (ksi)
- f_d = shear stress in the flange caused by the internal diaphragm vertical shear due to the factored loads (ksi)
- f_v = St. Venant torsional shear stress in the flange due to the factored loads (ksi)
- R_b = web load-shedding factor determined as specified in Article 6.10.1.10.2
- R_h = hybrid factor determined as specified in Article 6.10.1.10.1

Eq. C6.11.8.1.1-1 represents the general form of the Huber-von Mises-Hencky yield criterion (Ugural and Fenster, 1975).

For a box supported on two bearings, f_{by} in Eq. C6.11.8.1.1-1 is typically relatively small and can often be neglected.

The box flange may be considered effective with the internal diaphragm at interior-pier sections in making this check. A flange width equal to six times its thickness may be considered effective with the internal diaphragm. The shear stress in the flange, f_d , caused by the internal diaphragm vertical shear due to the factored loads can then be estimated as:

$$f_d = \frac{VQ}{I_{fc}} \quad (C6.11.8.1.1-2)$$

where:

- V = vertical shear in the internal diaphragm due to flexure plus St. Venant torsion (kip)
- Q = first moment of one-half the effective box-flange area about the neutral axis of the effective internal diaphragm section (in.³)
- I = moment of inertia of the effective internal diaphragm section (in.⁴)

Wherever an access hole is provided within the internal diaphragm, the effect of the hole should be considered in computing the section properties of the effective diaphragm section.

6.11.8.1.2—Continuously Braced Flanges in Tension

At the strength limit state, the following requirement shall be satisfied:

$$f_{bu} \leq \phi_f F_{nt} \quad (6.11.8.1.2-1)$$

where:

F_{nt} = nominal flexural resistance of the flange determined as specified in Article 6.11.8.3 (ksi)

6.11.8.2—Flexural Resistance of Box Flanges in Compression

6.11.8.2.1—General

The nominal flexural resistance of box flanges in compression without flange longitudinal stiffeners shall be determined as specified in Article 6.11.8.2.2. The nominal flexural resistance of box flanges in compression with flange longitudinal stiffeners shall be determined as specified in Article 6.11.8.2.3.

6.11.8.2.2—Unstiffened Flanges

The nominal flexural resistance of the compression flange, F_{nc} , shall be taken as:

C6.11.8.1.2

For continuously braced top flanges of tub sections, lateral flange bending need not be considered. St. Venant torsional shears are also typically neglected. The torsional shears may not be neglected, however, in a continuously braced box flange.

C6.11.8.2.2

For unstiffened flanges, the slenderness is based on the full flange width between webs, b_{fc} .

$$F_{nc} = F_{cb} \sqrt{1 - \left(\frac{f_v}{\phi_v F_{cv}} \right)^2} \quad (6.11.8.2.2-1)$$

in which:

F_{cb} = nominal axial compression buckling resistance of the flange under compression alone calculated as follows:

- If $\lambda_f \leq \lambda_p$, then:

$$F_{cb} = R_b R_h F_{yc} \Delta \quad (6.11.8.2.2-2)$$

- If $\lambda_p < \lambda_f \leq \lambda_r$, then:

$$F_{cb} = R_b R_h F_{yc} \left[\Delta - \left(\Delta - \frac{\Delta - 0.3}{R_h} \right) \left(\frac{\lambda_f - \lambda_p}{\lambda_r - \lambda_p} \right) \right] \quad (6.11.8.2.2-3)$$

- If $\lambda_f > \lambda_r$, then:

$$F_{cb} = \frac{0.9 E R_b k}{\lambda_f^2} \quad (6.11.8.2.2-4)$$

F_{cv} = nominal shear buckling resistance of the flange under shear alone calculated as follows:

- If $\lambda_f \leq 1.12 \sqrt{\frac{E k_s}{F_{yc}}}$, then:

$$F_{cv} = 0.58 F_{yc} \quad (6.11.8.2.2-5)$$

- If $1.12 \sqrt{\frac{E k_s}{F_{yc}}} < \lambda_f \leq 1.40 \sqrt{\frac{E k_s}{F_{yc}}}$, then:

$$F_{cv} = \frac{0.65 \sqrt{F_{yc} E k_s}}{\lambda_f} \quad (6.11.8.2.2-6)$$

- If $\lambda_f > 1.40 \sqrt{\frac{E k_s}{F_{yc}}}$, then:

$$F_{cv} = \frac{0.9 E k_s}{\lambda_f^2} \quad (6.11.8.2.2-7)$$

λ_f = slenderness ratio for the compression flange

$$= \frac{b_{fc}}{t_{fc}} \quad (6.11.8.2.2-8)$$

$$\lambda_p = 0.57 \sqrt{\frac{E k}{F_{yc} \Delta}} \quad (6.11.8.2.2-9)$$

For flanges under combined normal stress and torsional shear stress, the following nonlinear interaction curve is used to derive the resistance of the flange (NHI, 2011):

$$\left(\frac{f_v}{\phi_v F_{cv}} \right)^2 + \left(\frac{f_c}{\phi_f F_{cb}} \right)^2 \leq 1.0 \quad (C6.11.8.2.2-1)$$

Rearranging Eq. C6.11.8.2.2-1 in terms of f_c and substituting F_{nc} for f_c facilitates the definition of the nominal flexural resistance of the compression flange as provided in Eq. 6.11.8.2.2-1. A general discussion of the problem of reduction of critical local buckling stresses due to the presence of torsional shear may be found in Galambos (1998).

The nominal axial compression buckling resistance of the flange under compression alone, F_{cb} , is defined for three distinct regions based on the slenderness of the flange. The elastic buckling resistance of the flange given by Eq. 6.11.8.2.2-4 is based on the theoretical elastic Euler buckling equation for an infinitely long plate under a uniform normal stress (Timoshenko and Gere, 1961). For stocky plates, full yielding of the plate as defined by the von Mises yield criterion for combined normal and shear stress (Boresi et al., 1978) can be achieved. For such plates, F_{cb} is defined by Eq. 6.11.8.2.2-2. In between these two regions is a transition region that reflects the fact that partial yielding due to residual stresses and initial imperfections does not permit the attainment of the elastic buckling stress. The nominal flexural resistance of the flange in this region is expressed in Eq. 6.11.8.2.2-3 as a linear function of the flange slenderness. A residual stress level equal to $0.3 F_{yc}$ is assumed in the presence of no shear.

The limiting flange slenderness, λ_p , defining whether to use Eq. 6.11.8.2.2-2 or 6.11.8.2.2-3 is defined as 0.6 times the flange slenderness at which the elastic buckling stress given by Eq. 6.11.8.2.2-4 equals $R_b F_{yc} \Delta$. The limiting flange slenderness, λ_r , defining whether to use Eq. 6.11.8.2.2-3 or 6.11.8.2.2-4 is defined as the flange slenderness at which the elastic buckling stress given by Eq. 6.11.8.2.2-4 equals $R_b F_{yr}$, where F_{yr} is given by Eq. 6.11.8.2.2-13.

The equations for the nominal shear buckling resistance of the flange under shear alone, F_{cv} , are determined from the equations for the constant, C , given in Article 6.10.9.3.2, where C is the ratio of the shear buckling resistance to the shear yield strength of the flange taken as $F_{yc} / \sqrt{3}$.

The computation of the flange torsional shear stress, f_v , from Eq. 6.11.8.2.2-12 due to torques applied separately to the noncomposite and composite sections is discussed in Article C6.11.1.1. In cases where f_v is relatively small, consideration might be given to assuming Δ equal to 1.0 and F_{nc} equal to F_{cb} for preliminary design.

The specified plate-buckling coefficient for uniform normal stress, k , and shear-buckling coefficient, k_s , assume simply-supported boundary conditions at the edges of the flanges (Timoshenko and Gere, 1961).

$$\lambda_r = 0.95 \sqrt{\frac{Ek}{F_{yr}}} \quad (6.11.8.2.2-10)$$

$$\Delta = \sqrt{1 - 3 \left(\frac{f_v}{F_{yc}} \right)^2} \quad (6.11.8.2.2-11)$$

f_v = St. Venant torsional shear stress in the flange due to the factored loads at the section under consideration (ksi)

$$= \frac{T}{2A_o t_{fc}} \quad (6.11.8.2.2-12)$$

F_{yr} = smaller of the compression-flange stress at the onset of nominal yielding, with consideration of residual stress effects, or the specified minimum yield strength of the web (ksi)

$$= (\Delta - 0.3) F_{yc} \quad (6.11.8.2.2-13)$$

k = plate-buckling coefficient for uniform normal stress

$$= 4.0$$

k_s = plate-buckling coefficient for shear stress

$$= 5.34$$

where:

ϕ_f = resistance factor for flexure specified in Article 6.5.4.2

ϕ_v = resistance factor for shear specified in Article 6.5.4.2

b_{fc} = compression-flange width between webs (in.)

A_o = enclosed area within the box section (in.²)

R_b = web load-shedding factor determined as specified in Article 6.10.1.10.2

R_h = hybrid factor determined as specified in Article 6.10.1.10.1

T = internal torque due to the factored loads (kip-in.)

6.11.8.2.3—Longitudinally Stiffened Flanges

The nominal flexural resistance of the compression flange shall be taken as equal to the nominal flexural resistance for the compression flange without longitudinal stiffeners, determined as specified in Article 6.11.8.2.2, with the following substitutions:

- w shall be substituted for b_{fc} ,
- The plate-buckling coefficient for uniform normal stress, k , shall be taken as:
- If $n = 1$, then:

The term R_b is a postbuckling strength reduction factor that accounts for the reduction in the section flexural resistance caused by the shedding of compressive stresses from a slender web and the corresponding increase in the flexural stress within the compression flange. The R_h factor accounts for the reduced contribution of the web to the nominal flexural resistance at first yield in any flange element, due to earlier yielding of the lower strength steel in the web of a hybrid section. The R_b and R_h factors are discussed in greater detail in Articles C6.10.1.10.2 and C6.10.1.10.1, respectively. In calculating R_b and R_h for a tub section, use one-half of the effective box flange width in conjunction with one top flange and a single web, where the effective box flange width is defined in Article 6.11.1.1. For a closed-box section, use one-half of the effective top and bottom box flange width in conjunction with a single web.

C6.11.8.2.3

When a noncomposite unstiffened box flange becomes so slender that nominal flexural resistance of the flange decreases to an impractical level, longitudinal stiffeners can be added to the flange.

The nominal flexural resistance of a longitudinally-stiffened box flange is determined using the same basic equations specified for unstiffened box flanges in Article 6.11.8.2.2. The width, w , must be substituted for b_{fc} in the equations. The shear-buckling coefficient, k_s , for a stiffened plate to be used in the equations is given by Eq. 6.11.8.2.3-3, which comes from Culver (1972). The

- If $n = 1$, then:

$$k = \left(\frac{8I_s}{wt_{fc}^3} \right)^{\frac{1}{3}} \quad (6.11.8.2.3-1)$$

- If $n = 2$, then:

$$k = \left(\frac{0.894I_s}{wt_{fc}^3} \right)^{\frac{1}{3}} \quad (6.11.8.2.3-2)$$

$$1.0 \leq k \leq 4.0 \text{ and:}$$

- the plate-buckling coefficient for shear stress, k_s , shall be taken as:

$$k_s = \frac{5.34 + 2.84 \left(\frac{I_s}{wt_{fc}^3} \right)^{\frac{1}{3}}}{(n+1)^2} \leq 5.34 \quad (6.11.8.2.3-3)$$

where:

- I_s = moment of inertia of a single longitudinal flange stiffener about an axis parallel to the flange and taken at the base of the stiffener (in.⁴)
- n = number of equally spaced longitudinal flange stiffeners
- w = larger of the width of the flange between longitudinal flange stiffeners or the distance from a web to the nearest longitudinal flange stiffener (in.)

Compression-flange longitudinal stiffeners shall satisfy the requirements specified in Article 6.11.11.2.

plate-buckling coefficient for uniform normal stress, k , to be used in the equations is related to the stiffness of the longitudinal flange stiffeners and is derived from Eq. 6.11.11.2-2. k can take any value ranging from 1.0 to 4.0. However, a value of k ranging from 2.0 to 4.0 generally should be assumed. Eq. 6.11.8.2.3-1 applies for one longitudinal flange stiffener; i.e., $n = 1$, and Eq. 6.11.8.2.3-2 applies for two longitudinal flange stiffeners; i.e., $n = 2$. As discussed further in Article C6.11.11.2, as the number of stiffeners is increased beyond one, the required moment of inertia from Eq. 6.11.11.2-2 to achieve the desired k value begins to increase dramatically and eventually becomes nearly impractical. Therefore, for boxes of typical proportions, it is strongly recommended that the number of longitudinal flange stiffeners not exceed one for maximum economy.

Note that Eq. 6.11.11.2-2 is automatically satisfied by the longitudinal flange stiffener moment of inertia that is assumed in determining the k value from Eq. 6.11.8.2.3-1 or 6.11.8.2.3-2, as applicable, since Eqs. 6.11.8.2.3-1 and 6.11.8.2.3-2 are derived directly from Eq. 6.11.11.2-2. Another option in lieu of using Eq. 6.11.8.2.3-1 or 6.11.8.2.3-2 is to assume a k value and then determine the minimum required moment of inertia for each longitudinal flange stiffener from Eq. 6.11.11.2-2 that will provide the assumed value of k .

If the longitudinal flange stiffeners are very rigid, k will be at or near a value of 4.0 and plate buckling will be forced to occur between the stiffeners. Less rigid stiffeners will yield a lower value of k and a corresponding lower value of the flange nominal flexural resistance. Eqs. 6.11.8.2.3-1 and 6.11.8.2.3-2, or alternatively Eq. 6.11.11.2-2, allow the Engineer to match the required stiffener size to the required flange resistance rather than always providing the largest stiffener(s) required to obtain a k value equal to 4.0.

Longitudinal flange stiffeners are best discontinued at field splice locations, particularly when the span balance is such that the box flange on the other side of the field splice need not be stiffened. To accomplish this successfully, the flange splice plates must be split to allow the stiffener to be taken to the free edge of the flange where the flange normal stress is zero. The compressive resistance of the unstiffened box flange on the other side of the splice should be checked. Otherwise, if the stiffener must be discontinued in a region subject to a net tensile stress, determined as specified in Article 6.6.1.2.1, the termination of the stiffener-to-flange weld must be checked for fatigue according to the terminus detail. Where it becomes necessary to run the stiffener beyond the field splice, splicing the stiffener across the field splice is recommended.

6.11.8.3—Tension-Flange Flexural Resistance

The nominal flexural resistance of the tension flanges of tub sections shall be taken as:

$$F_m = R_h F_{yt} \quad (6.11.8.3-1)$$

where:

R_h = hybrid factor determined as specified in Article 6.10.1.10.1

The nominal flexural resistance of the tension flange of closed-box sections shall be determined from Eq. 6.11.7.2.2-5.

6.11.9—Shear Resistance

Except as specified herein, the provisions of Article 6.10.9 shall apply for determining the factored shear resistance of a single web. For the case of inclined webs, D in Article 6.10.9 shall be taken as the depth of the web plate measured along the slope.

For the case of inclined webs, each web shall be designed for a shear, V_{ui} , due to the factored loads taken as:

$$V_{ui} = \frac{V_u}{\cos \theta} \quad (6.11.9-1)$$

where:

V_u = vertical shear due to the factored loads on one inclined web (kip)
 θ = the angle of inclination of the web plate to the vertical (degrees)

For all single box sections, horizontally curved sections, and multiple box sections in bridges not satisfying the requirements of Article 6.11.2.3, or with box flanges that are not fully effective according to the provisions of Article 6.11.1.1, V_u shall be taken as the sum of the flexural and St. Venant torsional shears.

For box flanges, b_{fc} or b_{fs} , as applicable, shall be taken as one-half of the effective flange width between webs in checking Eq. 6.10.9.3.2-1, where the effective flange width shall be taken as specified in Article 6.11.1.1, but not to exceed $18t_f$ where t_f is the thickness of the box flange.

Web stiffeners shall satisfy the requirements of Article 6.11.11.1.

6.11.10—Shear Connectors

Except as specified herein, shear connectors shall be designed according to the provisions of Article 6.10.10.

Shear connectors shall be provided in negative flexure regions.

For all single box sections, horizontally curved sections, and multiple box sections in bridges not satisfying the requirements of Article 6.11.2.3, or with box flanges that are not fully effective according to the provisions of Article 6.11.1.1, shear connectors shall be

C6.11.9

For boxes with inclined webs, the web must be designed for the component of the vertical shear in the plane of the web.

Usually, the box webs are detailed with equal height webs. If the deck is superelevated, the box may be rotated to match the deck slope, which is generally preferred to simplify fabrication by maintaining symmetry of the girder sections. The result is that the inclination of one web is increased over what it would have been if the box were not rotated. The computed shear in that web due to vertically applied loads should be adjusted accordingly.

For the box sections specifically cited in this Article, including sections in horizontally curved bridges, St. Venant torsional shear must be considered in the design of the webs. The total shear in one web is greater than in the other web at the same section since the torsional shear is of opposite sign in the two webs. As a matter of practicality, both webs can be designed for the critical shear.

Although shear and longitudinal stresses in the webs due to warping are not zero, these effects are typically quite small and can be ignored in the design of the webs.

For multiple box sections in straight bridges satisfying the requirements of Article 6.11.2.3 for which a live load distribution factor for moment is employed, one-half the distribution factor for moment should be used in the calculation of the live load vertical shear in each web.

C6.11.10

Shear connectors must be present in regions of negative flexure to resist the torsional shear that exists along the entire span in all types of composite box sections. Also, the prototype and model bridges that were studied in the original development of the live-load distribution provisions for straight box sections had shear connectors throughout the negative flexure region.

Maximum flexural and torsional shears are typically not produced by concurrent loads. However, the

designed for the sum of the flexural and St. Venant torsional shears. The longitudinal fatigue shear range per unit length, V_{fat} , for one top flange of a tub girder shall be computed for the web subjected to additive flexural and torsional shears. The resulting shear connector pitch shall also be used for the other top flange. The radial fatigue shear range due to curvature, F_{fat} , given by Eq. 6.10.10.1.2-4 may be ignored in the design of box sections in straight or horizontally curved spans or segments.

For checking the resulting number of shear connectors to satisfy the strength limit state, the cross-sectional area of the steel box section under consideration and the effective area of the concrete deck associated with that box shall be used in determining P by Eqs. 6.10.10.4.2-2, 6.10.10.4.2-3, 6.10.10.4.2-7, and 6.10.10.4.2-8.

Shear connectors on composite box flanges shall be uniformly distributed across the width of the flange. The maximum transverse spacing, s_t , between shear connectors on composite box flanges shall satisfy the following requirement:

$$\frac{s_t}{t_f} \sqrt{\frac{F_{yf}}{kE}} \leq R_1 \quad (6.11.10-1)$$

where:

- k = plate-buckling coefficient for uniform normal stress determined as specified in Article 6.11.8.2
- R_1 = limiting slenderness ratio for the box flange determined from Eq. 6.11.8.2.2-8

For composite box flanges at the fatigue limit state, V_{sr} in Eq. 6.10.10.1.2-1 shall be determined as the vector sum of the longitudinal fatigue shear range given by Eq. 6.10.10.1.2-3 and the torsional fatigue shear range in the concrete deck. The number of shear connectors required to satisfy the strength limit state shall be determined according to the provisions of Article 6.10.10.4. In addition, the vector sum of the longitudinal and torsional shears due to the factored loads in the concrete deck per connector shall not exceed Q_c determined from Eq. 6.10.10.4.1-1.

6.11.11—Stiffeners

6.11.11.1—Web Stiffeners

Transverse intermediate web stiffeners shall be designed according to the provisions of Article 6.10.11.1.

Longitudinal web stiffeners shall be designed according to the provisions of Article 6.10.11.3.

Except as specified herein, bearing stiffeners shall be designed according to the provisions of Article 6.10.11.2. Bearing stiffeners should be attached to diaphragms rather than inclined webs. For bearing stiffeners attached to diaphragms, the provisions of Article 6.10.11.2.4b shall apply to the diaphragm rather than to the web. At

interaction between flexure and torsion due to moving loads is too complex to treat practically. Instead, for cases where the torsional shear must be considered, these provisions allow the longitudinal shear range for fatigue to be computed from Eq. 6.10.10.1.2-3 using the sum of the maximum flexural and torsional shears in the web subjected to additive shears. The shear range and the resulting pitch should be computed using one-half the moment of inertia of the composite box section. The top flange over the other web, or the other half of the flange for a closed-box section, should contain an equal number of shear connectors. Because of the inherent conservatism of these requirements, the radial fatigue shear range due to curvature need not be included when computing the horizontal fatigue shear range for box sections in either straight or horizontally curved spans or segments.

Shear connectors on box flanges are best distributed uniformly across the flange width to ensure composite action of the entire flange with the concrete. The shear connectors are to be spaced transversely to satisfy Eq. 6.11.10-1 in order to help prevent local buckling of the flange plate when subject to compression. The torsional shear or shear range resisted by the concrete deck can be determined by multiplying the torsional shear or shear range acting on the top of the composite box section by the ratio of the thickness of the transformed concrete deck to the total thickness of the top flange plus the transformed deck. Adequate transverse reinforcement should be provided in the deck to resist this torsional shear.

C6.11.11.1

When inclined webs are used, bearing stiffeners should be attached to either an internal or external diaphragm rather than to the webs so that the bearing stiffeners are perpendicular to the sole plate. Thermal movements of the bridge may cause the diaphragm to be eccentric with respect to the bearings. This eccentricity should be recognized in the design of the diaphragm and bearing stiffeners. The effects of the eccentricity are usually most critical when the bearing stiffeners are attached to diaphragms. The effects of the eccentricity can

expansion bearings, bearing stiffeners and diaphragms should be designed for eccentricity due to thermal movement.

6.11.11.2—Longitudinal Compression-Flange Stiffeners

Longitudinal compression-flange stiffeners on box flanges shall be equally spaced across the flange width. The specified minimum yield strength of the stiffeners shall not be less than the specified minimum yield strength of the box flange to which they are attached.

The projecting width, b_ℓ , of a flange longitudinal stiffener element shall satisfy:

$$b_\ell \leq 0.48t_s \sqrt{\frac{E}{F_{yc}}} \quad (6.11.11.2-1)$$

where:

t_s = thickness of the projecting longitudinal stiffener element (in.)

The moment of inertia, I_ℓ , of each stiffener about an axis parallel to the flange and taken at the base of the stiffener shall satisfy:

$$I_\ell \geq \psi w t_s^3 \quad (6.11.11.2-2)$$

where:

ψ = $0.125k^3$ for $n = 1$
 = $1.120k^3$ for $n = 2$
 k = plate-buckling coefficient for uniform normal stress
 = $1.0 \leq k \leq 4.0$
 n = number of equally spaced longitudinal flange stiffeners
 w = larger of the width of the flange between longitudinal flange stiffeners or the distance from a web to the nearest longitudinal flange stiffener (in.)

be recognized by designing the bearing stiffener assembly as a beam-column according to the provisions of Articles 6.10.11.2 and 6.9.2.2.

C6.11.11.2

Eq. 6.11.11.2-1 is intended to prevent local buckling of the projecting elements of the longitudinal flange stiffener. For structural tees, b_ℓ should be taken as one-half the width of the flange.

Eq. 6.11.11.2-2 for the required longitudinal flange stiffener moment of inertia, I_ℓ , is an approximate expression that within its range of applicability yields values of the elastic critical flange buckling stress close to those obtained by use of the exact but cumbersome equations of elastic stability (Timoshenko and Gere, 1961). The required size of the stiffener increases as the panel becomes smaller since the buckling resistance of the panels increases as the panels become smaller.

The actual longitudinal flange stiffener moment of inertia, I_s , used in determining the plate-buckling coefficient for uniform normal stress, k , from either Eq. 6.11.8.2.3-1 or 6.11.8.2.3-2, as applicable, automatically satisfies Eq. 6.11.11.2-2 when that value of k is used since the equations for k are derived directly from Eq. 6.11.11.2-2. Alternatively, a k value can be assumed in lieu of using Eq. 6.11.8.2.3-1 or 6.11.8.2.3-2. k can take any value ranging from 1.0 to 4.0. However, a value of k ranging from 2.0 to 4.0 generally should be assumed. The minimum required moment of inertia for each longitudinal flange stiffener that will provide the assumed value of k can then be determined from Eq. 6.11.11.2-2.

Where required, the number of longitudinal flange stiffeners should preferably not exceed one for maximum economy in boxes of typical proportions. Eq. 6.11.11.2-2 assumes that the box flange plate and the stiffeners are infinitely long and ignores the effect of any transverse bracing or stiffening. Thus, when n exceeds 1, the required moment of inertia from Eq. 6.11.11.2-2 begins to increase dramatically. When n exceeds 2, for which the value of ψ equals $0.07k^3n^4$, the required moment of inertia from Eq. 6.11.11.2-2 becomes nearly impractical.

For rare cases where an exceptionally wide box flange is required and n may need to exceed 2, it is suggested that transverse flange stiffeners be considered to reduce the required size of the longitudinal flange stiffeners to a more practical value. The use of transverse flange stiffeners might also be considered for the case where n equals 2 if a k value greater than about 2.5 is needed and it is desired to reduce the required size of the longitudinal stiffeners over that given by Eq. 6.11.11.2-2. The specified minimum yield strength of the transverse flange stiffeners should not be less than the specified minimum yield strength of the box flange. Individual structural tees can be used as transverse flange stiffeners, and/or a bottom strut, provided within the internal transverse bracing of the box and

satisfying the requirements of Article 6.11.5, can serve as a transverse flange stiffener if the strut also satisfies the stiffness requirement given by Eq. C6.11.11.2-4. In either case, the transverse flange stiffeners should be attached to the longitudinal flange stiffeners by bolting. The connection to each longitudinal stiffener should be designed to resist the following vertical force:

$$F_s = \frac{\phi_f F_{ys} S_s}{nb_{fc}} \quad (\text{C6.11.11.2-1})$$

where:

- ϕ_f = resistance factor for flexure specified in Article 6.5.4.2
- F_{ys} = specified minimum yield strength of the transverse flange stiffener (ksi)
- S_s = section modulus of the transverse flange stiffener (in.^3)

Individual structural tees serving as transverse flange stiffeners should also be attached to the webs of the box. The connection of transverse flange stiffeners to each web should be designed to resist the following vertical force:

$$F_w = \frac{\phi_f F_{ys} S_s}{2b_{fc}} \quad (\text{C6.11.11.2-2})$$

For the exceptional case where transverse flange stiffeners are deemed necessary, the constant ψ in Eq. 6.11.11.2-2 is to be taken as 8.0 in determining the required moment of inertia of the longitudinal flange stiffeners. n in this case should preferably not exceed five. The longitudinal spacing of the transverse flange stiffeners should not exceed three times the full width of the box flange, b_{fc} , in order for the transverse stiffeners to be considered effective. The plate-buckling coefficient, k , for uniform normal stress to be used in the equations of Article 6.11.8.2.2 in lieu of k determined from Eqs. 6.11.8.2.3-1 or 6.11.8.2.3-2 may then be taken as follows:

$$k = \frac{\left[1 + \left(a/b_{fc}\right)^2\right]^2 + 87.3}{(n+1)^2 \left(a/b_{fc}\right)^2 \left[1 + 0.1(n+1)\right]} \leq 4.0 \quad (\text{C6.11.11.2-3})$$

where:

- a = longitudinal spacing of the transverse flange stiffeners (in.)

Transverse flange stiffeners spaced at a distance less than or equal to $4w$ will provide a k of approximately 4.0 according to Eq. C6.11.11.2-3 when n does not exceed 5. When the k value from Eq. C6.11.11.2-3 is used, the moment of inertia, I_t , of each transverse flange stiffener about an axis through its centroid and parallel to its bottom edge must satisfy:

$$I_t \geq 0.05(n+1)^3 w^3 \frac{f_s A_f}{E a} \quad (\text{C6.11.11.2-4})$$

where:

- A_f = area of the box flange including the longitudinal flange stiffeners (in.²)
 f_s = largest of the longitudinal flange stresses due to the factored loads in the panels on either side of the transverse flange stiffener under consideration (ksi)

Structural tees are preferred for longitudinal flange stiffeners because a tee provides a high ratio of stiffness to cross-sectional area. Tees also minimize the potential for lateral torsional buckling of the stiffeners. Using less efficient flat bars as stiffeners is an undesirable alternative. Since the longitudinal flange stiffeners are primary load carrying members, the specified minimum yield strength of the stiffeners must not be less than the specified minimum yield strength of the box flange to which they are attached. Tees may not be available in higher grades of steel. In these cases, tees can be fabricated from plates or bars cut from plate.

Longitudinal flange stiffeners should be continuous through internal diaphragms. Consideration should be given to attaching longitudinal flange stiffeners to the internal diaphragms. Tees may be conveniently attached to the diaphragms with a pair of clip angles.

For the cases specified in Article 6.11.5 where transverse bending stresses due to cross-section distortion are to be considered for fatigue, it may be necessary in certain situations to consider providing bottom transverse bracing members as part of the internal cross-frames to control distortion of the box flange and reduce the transverse bending stress ranges in the flange. Where longitudinal flange stiffeners are used, the transverse member is to be attached to the longitudinal stiffeners by bolting. As discussed previously in this Article, bottom transverse bracing members and/or individual transverse flange stiffeners attached to the longitudinal flange stiffeners may also be necessary in the unusual case of an exceptionally wide box flange. For all other cases, additional transverse stiffening of box flanges is not required. It should be emphasized that bottom transverse bracing members and their connections, where provided, need not satisfy the requirements of Eqs. C6.11.11.2-1, C6.11.11.2-2 and C6.11.11.2-4, unless the k value from Eq. C6.11.11.2-3 is utilized in the design of the box flange.

6.12—MISCELLANEOUS FLEXURAL MEMBERS**6.12.1—General****6.12.1.1—Scope**

The provisions of this Article shall apply to:

- Noncomposite H-shaped members bent about either axis of the cross-section, and noncomposite I-shaped members bent about their weak axis;
- Noncomposite box shaped member, including square and rectangular HSS;
- Noncomposite circular tubes, including round HSS;
- Channels, angles, tees, rectangular bars, and solid rounds;
- Concrete-encased rolled shapes; and
- Composite tubes.

6.12.1.2—Strength Limit State*6.12.1.2.1—Flexure*

The factored flexural resistance, M_r , shall be taken as:

$$M_r = \phi_f M_n \quad (6.12.1.2.1-1)$$

where:

M_n = nominal flexural resistance specified in Articles 6.12.2.2 and 6.12.2.3 for noncomposite and composite members, respectively (kip-in.)

ϕ_f = resistance factor for flexure specified in Article 6.5.4.2

6.12.1.2.2—Combined Flexure and Axial Load

The provisions of Article 6.8.2.3 for combined axial tension and flexure or the provisions of Article 6.9.2.2 for combined axial compression and flexure shall apply, as applicable.

C6.12.1.1

This Article covers miscellaneous rolled or built-up noncomposite or composite members subject to flexure, often in combination with axial loads; that is, flexural members not covered by the provisions of Article 6.10 or 6.11. Included are doubly symmetric noncomposite box-shaped members utilized in trusses, frames, and arches, and angles, tees, and channels utilized as cross-frame, diaphragm, and lateral bracing members.

Noncomposite circular tubes or pipes may be designed using the provisions specified herein for round Hollow Structural Sections (HSS) provided that they conform to ASTM A53, Grade B and the appropriate parameters are used in the design. Additional information on connection design for square, rectangular and round HSS may be found in Chapter K of AISC (2005). Resistances for fatigue design for square, rectangular and round HSS may be found in Section 2.20.6 of the ANSI/AWS D1.1 *Structural Welding Code* or in Section 11 of the *AASHTO Standard Specifications for Structural Supports for Highway Signs, Luminaries and Traffic Signals*. Where these members are used in fracture-critical applications, refer to Article 8.2.3 of the *Guide Specifications for the Design of Pedestrian Bridges*.

6.12.1.2.3—Shear

6.12.1.2.3a—General

The factored shear resistance, V_r , shall be taken as:

$$V_r = \phi_v V_n \quad (6.12.1.2.3a-1)$$

where:

V_n = nominal shear resistance specified in Articles 6.10.9.2 and 6.12.3 for webs of noncomposite members and composite members, respectively; except for webs of noncomposite box-shaped members, including square and rectangular HSS, for which the provisions of Article 6.11.9 shall apply, and circular tubes, including round HSS, for which the provisions of Article 6.12.1.2.3c shall apply (kip).

ϕ_v = resistance factor for shear specified in Article 6.5.4.2

For stems of tees and for elements of noncomposite I- and H-shapes loaded about their weak axis, the shear buckling coefficient, k , shall be taken as 1.2.

6.12.1.2.3b—Square and Rectangular HSS

For square and rectangular HSS, the web depth, D , shall be taken as the clear distance between flanges less the inside corner radius on each side and the area of both webs shall be considered effective in resisting the shear.

6.12.1.2.3c—Circular Tubes

For circular tubes, including round HSS, the nominal shear resistance, V_n , shall be taken as:

$$V_n = 0.5F_{cr}A_g \quad (6.12.1.2.3c-1)$$

in which:

F_{cr} = shear buckling resistance (ksi) taken as the larger of either:

$$F_{cr1} = \frac{1.60E}{\sqrt{\frac{L_v}{D} \left(\frac{D}{t}\right)^{\frac{5}{4}}}} \leq 0.58F_y \quad (6.12.1.2.3c-2)$$

or:

$$F_{cr2} = \frac{0.78E}{\left(\frac{D}{t}\right)^{\frac{3}{2}}} \leq 0.58F_y \quad (6.12.1.2.3c-3)$$

C6.12.1.2.3c

The provisions for circular tubes, including round Hollow Structural Sections (HSS), subject to transverse shear are based on the provisions for local buckling of cylinders due to torsion. However, since torsion is generally constant along the member length and transverse shear typically has a gradient, the critical buckling stress for transverse shear is taken as 1.3 times the critical stress for torsion (Brockenbrough and Johnston 1981; Galambos 1998). The torsion equations apply over the full length of the member, but for transverse shear, it is reasonable to use the length between points of maximum and zero shear. The nominal shear resistance is computed assumed that the shear stress at the neutral axis is at F_{cr} . The resulting stress at the neutral axis is $V/\pi Rt$, in which the denominator is recognized as half the area of the circular tube.

where:

- A_g = gross area of the section based on the design wall thickness (in.)
- D = outside diameter of the tube (in.)
- L_v = distance between points of maximum and zero shear (in.)
- t = design wall thickness taken equal to 0.93 times the nominal wall thickness for electric-resistance-welded round HSS and taken equal to the nominal wall thickness for all others (in.)

6.12.2—Nominal Flexural Resistance

6.12.2.1—General

Except as specified herein, provisions for lateral torsional buckling need not be applied to composite members, noncomposite box-shaped members, noncomposite I- and H-shaped members bent about their weak axis, and circular tubes.

6.12.2.2—Noncomposite Members

6.12.2.2.1—I- and H-Shaped Members

The provisions of this Article apply to I- and H-shaped members and members consisting of two channel flanges connected by a web plate.

The provisions of Article 6.10 shall apply to flexure about an axis perpendicular to the web.

The nominal flexural resistance for flexure about the weak axis shall be taken as:

- If $\lambda_f \leq \lambda_{pf}$, then:

$$M_n = M_p \tag{6.12.2.2.1-1}$$

- If $\lambda_{pf} < \lambda_f \leq \lambda_{rf}$, then:

$$M_n = \left[1 - \left(1 - \frac{S_y}{Z_y} \right) \left(\frac{\lambda_f - \lambda_{pf}}{0.45 \sqrt{\frac{E}{F_{yf}}}} \right) \right] F_{yf} Z_y \tag{6.12.2.2.1-2}$$

in which:

λ_f = slenderness ratio for the flange

$$= \frac{b_f}{2t_f} \tag{6.12.2.2.1-3}$$

λ_{pf} = limiting slenderness ratio for a compact flange

C6.12.2.2.1

Eqs. 6.12.2.2.1-1 and 6.12.2.2.1-2 are taken from Appendix F of AISC (1999), except that the flange slenderness λ_{rf} corresponding to the transition from inelastic to elastic flange local buckling is consistently set based on the yield moment in weak-axis bending $F_{yf}S_y$. AISC (1999) uses $F_{yf}S_y$ as the moment corresponding to the inelastic-to-elastic flange local buckling transition, but then specifies λ_{rf} based on a smaller moment level. The approach adopted in these provisions is interpreted as a corrected form of the AISC (1999) equations and is conservative relative to the AISC (1999) equations as printed. The yield moment $F_{yf}S_y$ may be taken conservatively as the moment at the inelastic-to-elastic flange local buckling transition because of the beneficial effects of the stress gradient in the flange associated with weak-axis bending.

For H-shaped members $M_p = 1.5F_yS$, where S is the elastic section modulus about this axis.

$$= 0.38 \sqrt{\frac{E}{F_{yf}}} \quad (6.12.2.2.1-4)$$

λ_{yf} = limiting slenderness ratio for a noncompact flange

$$= 0.83 \sqrt{\frac{E}{F_{yf}}} \quad (6.12.2.2.1-5)$$

where:

F_{yf} = specified minimum yield strength of the lower-strength flange (ksi)

M_p = plastic moment about the weak axis (kip-in.)

S_y = elastic section modulus about the weak axis (in.³)

Z_y = plastic section modulus about the weak axis (in.³)

6.12.2.2.2—Box-Shaped Members

Except as specified herein, for homogeneous doubly symmetric box-shaped members bent about either axis, the nominal flexural resistance shall be taken as:

$$M_n = F_y S \left[1 - \frac{0.064 F_y S \ell}{AE} \left(\frac{\sum \left(\frac{b}{t} \right)}{I_y} \right)^{0.5} \right] \quad (6.12.2.2.2-1)$$

where:

S = section modulus about the flexural axis (in.³)

A = area enclosed within the centerlines of the plates comprising the box (in.²)

ℓ = unbraced length (in.)

I_y = moment of inertia about an axis perpendicular to the axis of bending (in.⁴)

b/t = width of any flange or depth of any web component divided by its thickness neglecting any portions of flanges or webs that overhang the box perimeter

For square and rectangular HSS bent about either axis, the nominal flexural resistance shall be taken as the smallest value based on yielding, flange local buckling or web local buckling, as applicable.

For yielding, the nominal flexural resistance for square and rectangular HSS shall be taken as:

$$M_n = M_p = F_y Z \quad (6.12.2.2.2-2)$$

where:

M_p = plastic moment (kip-in.)

Z = plastic section modulus about the axis of bending (in.³)

C6.12.2.2.2

The lateral-torsional resistance of box shapes is usually quite high and its effect is often ignored. For truss members, frame members, arch ribs, and other situations in which long unbraced lengths are possible, this expediency may not be adequate. Eq. 6.12.2.2.2-1 was derived from the elastic lateral torsional buckling moment, M_{CR} , given by:

$$M_{CR} = \frac{\pi}{\ell} \sqrt{EI_y GJ} \quad (C6.12.2.2.2-1)$$

in which:

$$G = 0.385E, \text{ and} \quad (C6.12.2.2.2-2)$$

$$J = \frac{4A^2}{\sum \frac{b}{t}} \quad (C6.12.2.2.2-3)$$

After substitution of Eqs. C6.12.2.2.2-2 and C6.12.2.2.2-3 into C6.12.2.2.2-1:

$$M_{CR} = \frac{3.90 EA}{\ell} \sqrt{\frac{I_y}{\sum \frac{b}{t}}} \quad (C6.12.2.2.2-4)$$

It was assumed that buckling would be in the inelastic range so the CRC column equation was used to estimate the effect of inelastic buckling as:

$$M_n = F_y S \left[1 - \frac{F_y S}{4M_{CR}} \right] \quad (C6.12.2.2.2-5)$$

Where the flange slenderness λ_f of square and rectangular HSS exceeds λ_{rf} , flange local buckling shall be checked. For flange local buckling, the nominal flexural resistance shall be taken as:

- If $\lambda_f \leq \lambda_{rf}$, then:

$$M_n = M_p - (M_p - F_y S) \left(3.57 \frac{b_{fc}}{t_{fc}} \sqrt{\frac{F_y}{E}} - 4.0 \right) \leq M_p \quad (6.12.2.2.2-3)$$

- If $\lambda_f > \lambda_{rf}$, then:

$$M_n = F_y S_{eff} \quad (6.12.2.2.2-4)$$

in which:

$$\begin{aligned} \lambda_f &= \text{compression-flange slenderness} = b_{fc}/t_{fc} \\ \lambda_{rf} &= \text{limiting slenderness for a compact flange} \\ &= 1.12 \sqrt{\frac{E}{F_y}} \end{aligned} \quad (6.12.2.2.2-5)$$

$$\begin{aligned} \lambda_{rf} &= \text{limiting slenderness for a noncompact flange} \\ &= 1.40 \sqrt{\frac{E}{F_y}} \end{aligned} \quad (6.12.2.2.2-6)$$

where:

- b_{fc} = clear width of the compression flange between the webs less the inside corner radius on each side (in.)
- S = elastic section modulus about the axis of bending (in.³)
- S_{eff} = effective elastic section modulus about the axis of bending determined using an effective width of the compression flange b_e (in.³), determined as:

$$b_e = 1.92 t_{fc} \sqrt{\frac{E}{F_y}} \left[1 - \frac{0.38}{(b_{fc}/t_{fc}) \sqrt{\frac{E}{F_y}}} \right] \leq b_{fc} \quad (6.12.2.2.2-7)$$

- t_{fc} = design wall thickness of the compression flange taken equal to 0.93 times the nominal wall thickness for electric-resistance-welded HSS and taken equal to the nominal wall thickness for all others (in.)

Where the flange slenderness λ_f of square and rectangular HSS exceeds λ_{rf} , the following shall also be satisfied at the fatigue and service limit states, and for constructibility:

Substitution of Eq. C6.12.2.2.2-4 into C6.12.2.2.2-5 leads to Eq. 6.12.2.2.2-1. The effects of moment gradient are conservatively neglected in Eq. 6.12.2.2.2-1.

For smaller square and rectangular Hollow Structural Sections (HSS), lateral torsional buckling is not considered and larger nominal flexural resistances potentially exceeding M_y may be obtained. Rectangular HSS bent about the weak or minor axis are not subject to lateral torsional buckling. For lateral torsional buckling about the major axis, the reduction in the lateral torsional buckling resistance for uniform bending, based on an assumed linear reduction between the plastic moment and yield moment, is typically minor in most practical cases. Furthermore, a moment gradient modifier, C_b , only slightly larger than unity makes this reduction nonexistent. For local buckling of the compression flanges of HSS, Eq. 6.12.2.2.2-4 for members with slender flanges utilizes the same effective width equation utilized for square or rectangular HSS in axial compression in Article 6.9.4.2.2, except that the stress f in Eq. 6.9.4.2.2-10 is taken as F_y . This substitution implies that the stress in the corners of the compression flange is at yield when the ultimate post-buckling resistance of the flange is reached. In such cases, the nominal flexural resistance is determined based on an effective section modulus to the compression flange using the distance from the shifted neutral axis. A conservative estimate of the nominal flexural resistance may be obtained by using the effective width from Eq. 6.12.2.2.2-7 for both the compression and tension flange in order to maintain symmetry of the cross-section and simplify the calculations. Since post-buckling resistance is assumed at the strength limit state for members with slender flanges, such members must also satisfy Eq. 6.12.2.2.2-8 to ensure that local buckling of the compression flange does not theoretically occur at the service and fatigue limit states, and for constructibility. Similar checks exist in the specification to ensure that shear buckling and web bend buckling do not theoretically occur under these conditions.

$$f_c \leq \frac{1.96E}{\lambda_f^2} \quad (6.12.2.2.2-8)$$

where:

f_c = compression-flange stress at the section under consideration due to:

- The Service II loads at the service limit state;
- The unfactored permanent load plus the Fatigue I load combination at the fatigue limit state;
- The appropriate factored permanent load for constructibility.

Where the web slenderness, D/t_w , of square and rectangular HSS exceeds λ_{pw} , web local buckling shall be checked. For web local buckling, the nominal flexural resistance shall be taken as:

$$M_n = M_p - (M_p - F_y S) \left(0.305 \frac{D}{t_w} \sqrt{\frac{F_y}{E}} - 0.738 \right) \leq M_p \quad (6.12.2.2.2-9)$$

in which:

$$\begin{aligned} \lambda_{pw} &= \text{limiting slenderness for a compact web} \\ &= 2.42 \sqrt{\frac{E}{F_y}} \end{aligned} \quad (6.12.2.2.2-10)$$

where:

- D = clear distance between the flanges less the inside corner radius on each side (in.)
- t_w = design wall thickness of the web taken equal to 0.93 times the nominal wall thickness for electric-resistance-welded HSS and taken equal to the nominal wall thickness for all others (in.)

6.12.2.2.3—Circular Tubes

For circular tubes, including round HSS, the nominal flexural resistance shall be taken as the smaller value based on yielding or local buckling, as applicable. The D/t of circular tubes used as flexural members shall not exceed $0.45E/F_y$.

For yielding, the nominal flexural resistance shall be taken as:

$$M_n = M_p = F_y Z \quad (6.12.2.2.3-1)$$

where:

- D = outside diameter of tube (in.)

C6.12.2.2.3

Failure modes and post-buckling behavior of circular tubes, including round Hollow Structural Sections (HSS), can be grouped into the following three categories (Sherman, 1992; Galambos, 1998): 1) for D/t less than about $0.05E/F_y$, a long inelastic plateau occurs in the moment-rotation curve. The cross-section gradually ovalizes, then local wave buckles eventually form after which the flexural resistance slowly decays; 2) for $0.05E/F_y \leq D/t \leq 0.10E/F_y$, the plastic moment is nearly achieved but a single local buckle develops and the flexural resistance decays slowly with little or no inelastic plateau; and 3) for $D/t > 0.10E/F_y$, multiple buckles form suddenly with little ovalization and the flexural resistance drops rapidly to a more stable level. The specified

M_p = plastic moment (kip-in.)
 t = thickness of tube (in.)
 Z = plastic section modulus (in.³)

For sections where D/t exceeds $0.07E/F_y$, local buckling shall be checked. For local buckling, the nominal flexural resistance shall be taken as:

- If $\frac{D}{t} \leq \frac{0.31E}{F_y}$, then:

$$M_n = \left(\frac{0.021E}{\frac{D}{t}} + F_y \right) S \quad (6.12.2.2.3-2)$$

- If $\frac{D}{t} > \frac{0.31E}{F_y}$, then:

$$M_n = F_{cr} S \quad (6.12.2.2.3-3)$$

in which:

$$\begin{aligned}
 F_{cr} &= \text{elastic local buckling stress (ksi)} \\
 &= \frac{0.33E}{\frac{D}{t}} \quad (6.12.2.2.3-4)
 \end{aligned}$$

where:

S = elastic section modulus (in.³)

6.12.2.2.4—Tees and Double Angles

For tees and double angles loaded in the plane of symmetry, the nominal flexural resistance shall be taken as the smallest value based on yielding, lateral torsional buckling, or local buckling of the elements, as applicable.

For yielding, the nominal flexural resistance shall be taken as:

$$M_n = M_p = F_y Z_x \quad (6.12.2.2.4-1)$$

M_n from Eq. 6.12.2.2.4-1 is limited to $1.6M_y$ for stems in tension and to M_y for stems in compression.

where:

F_y = specified minimum yield strength (ksi)
 M_p = plastic moment (kip-in.)
 M_y = yield moment based on the distance to the tip of the stem (kip-in.)
 Z_x = plastic section modulus about the x -axis (in.³)

flexural resistance equations reflect the above regions of behavior for sections with long constant moment regions and little restraint against ovalization at the failure location. The equations are based on five North American studies involving hot-formed seamless pipe, electric-resistance-welded pipe, and fabricated tubing (Sherman, 1992; Galambos, 1998).

C6.12.2.2.4

The provisions for tees and double angles given in this Article are taken from AISC (2005). The plane of symmetry is assumed to be that formed by their weak axis or y -axis. For flexure of tees and double angles about the y -axis, which is considered to be a rare case in bridge applications, consult the Commentary to Section F9 of AISC (2005).

The limit on M_n in Eq. 6.12.2.2.4-1 of $1.6M_y$ for cases where the stem is in tension is intended to indirectly control situations where significant yielding of the stem may occur at service load levels. The legs of double angles in continuous contact or with separators may together be assumed treated as the stem in checking the equations of this Article.

Eq. 6.12.2.2.4-2 is a simplified version of the elastic lateral torsional buckling equation developed in Kitipornchai and Trahair (1980) and discussed further in Ellifritt et al. (1992). The moment gradient modifier C_b specified for I-sections in Article A6.3.3 is not included in Eq. 6.12.2.2.4-2 as the application of C_b to cases where the

For lateral torsional buckling, the nominal flexural resistance shall be taken as:

$$M_n = \frac{\pi \sqrt{EI_y GJ}}{L_b} \left[B + \sqrt{1 + B^2} \right] \leq M_p \quad (6.12.2.2.4-2)$$

in which:

$$B = \pm 2.3 \frac{d}{L_b} \sqrt{\frac{I_y}{J}} \quad (6.12.2.2.4-3)$$

where:

- d = total depth of the section (in.)
- G = shear modulus of elasticity for steel = $0.385E$ (ksi)
- I_y = moment of inertia about the y -axis (in.⁴)
- J = St. Venant torsional constant (in.⁴)
- L_b = unbraced length (in.)

The plus sign for B in Eq. 6.12.2.2.4-3 shall apply when the stem is in tension and the minus sign shall apply when the stem is in compression. If the tip of the stem is in compression anywhere along the unbraced length, the negative value of B shall be used.

For sections where the flange is in compression and the flange slenderness λ_f exceeds λ_{pf} , flange local buckling shall be checked. For flange local buckling, the nominal flexural resistance shall be taken as:

$$M_n = M_p - \left(M_p - 0.7F_y S_{xc} \right) \left(\frac{\lambda_f - \lambda_{pf}}{\lambda_{rf} - \lambda_{pf}} \right) \leq 1.6M_y \quad (6.12.2.2.4-4)$$

in which:

$$\lambda_f = \text{flange slenderness} = b_f / 2t_f$$

$$\lambda_{pf} = \text{limiting slenderness for a compact flange}$$

$$= 0.38 \sqrt{\frac{E}{F_y}} \quad (6.12.2.2.4-5)$$

$$\lambda_{rf} = \text{limiting slenderness for a noncompact flange}$$

$$= 1.0 \sqrt{\frac{E}{F_y}} \quad (6.12.2.2.4-6)$$

where:

- b_f = flange width (in.). For double angles, b_f shall be taken as the sum of the widths of the outstanding legs.
- S_{xc} = elastic section modulus with respect to the compression flange (in.³)

stem is in compression is unconservative. Also, for reverse curvature bending, the portion with the stem in compression may govern the lateral torsional buckling resistance even though the corresponding moments may be small in relation to the moments in the other portions of the unbraced length. The lateral torsional buckling resistance for the case where the stem is in compression is substantially smaller than for the case where the stem is in tension. For cases where the stem is in tension, connection details should be designed to minimize end restraint moments that may cause the stem to be in flexural compression at the ends of the member.

For rolled sections, the St. Venant torsional constant J , including the effect of the web-to-flange fillets, is tabulated in AISC (2005a). For fabricated sections, Eq. A6.3.3-9 may be used with one of the flange terms removed.

For cases where the flange is in compression and λ_f does not exceed λ_{pf} , flange local buckling does not control and need not be checked. Eq. 6.12.2.2.4-4 represents an inelastic flange local buckling resistance equation and corrects an error in the inelastic flange local buckling equation provided in AISC (2005). An elastic flange local buckling resistance equation for cases with λ_f exceeding λ_{rf} , i.e. for slender flanges, is not provided because the limiting slenderness value λ_{rf} beyond which elastic flange local buckling controls is larger than the limiting slenderness value of 12.0 given by Eq. 6.10.2.2-1. The flanges of all rolled tee sections given in AISC (2005) satisfy Eq. 6.10.2.2-1; therefore, this limit need only be checked for fabricated sections. An elastic flange local buckling equation is provided in AISC (2005).

Eq. 6.12.2.2.4-7 for checking local buckling of stems in compression is indirectly derived from Eq. 6.12.2.2.4-2 in the limit of zero unbraced length.

t_f = flange thickness (in.)

For sections where the stem is in compression, local buckling of the stem shall be checked. The local buckling resistance of the stem shall be taken as:

$$M_n = 0.424 \frac{EJ}{d} \leq M_y \quad (6.12.2.2.4-7)$$

Flanges of fabricated sections in compression or tension shall satisfy Eq. 6.10.2.2-1.

6.12.2.2.5—Channels

For channels in flexure about their strong or x -axis, the nominal flexural resistance shall be taken as the smaller value based on yielding or lateral torsional buckling, as applicable.

For yielding, the nominal flexural resistance shall be taken as:

$$M_n = M_p = F_y Z_x \quad (6.12.2.2.5-1)$$

where:

F_y = specified minimum yield strength (ksi)

M_p = plastic moment (kip-in.)

Z_x = plastic section modulus about the x -axis (in.³)

Where the unbraced length L_b exceeds L_p , lateral torsional buckling shall be checked. For lateral torsional buckling, the nominal flexural resistance shall be taken as:

- If $L_b \leq L_r$, then:

$$M_n = C_b \left[M_p - (M_p - 0.7F_y S_x) \left(\frac{L_b - L_p}{L_r - L_p} \right) \right] \leq M_p \quad (6.12.2.2.5-2)$$

- If $L_b > L_r$, then:

$$M_n = F_{cr} S_x \leq M_p \quad (6.12.2.2.5-3)$$

in which:

F_{cr} = elastic lateral torsional buckling stress (ksi)

$$= \frac{C_b \pi^2 E}{\left(\frac{L_b}{r_{ts}} \right)^2} \sqrt{1 + 0.078 \frac{Jc}{S_x h_o} \left(\frac{L_b}{r_{ts}} \right)^2} \quad (6.12.2.2.5-4)$$

$$c = \frac{h_o}{2} \sqrt{\frac{I_y}{C_w}} \quad (6.12.2.2.5-5)$$

C6.12.2.2.5

The provisions for channels in flexure about their strong or x -axis are taken from AISC (2005). For lateral torsional buckling, where L_b is less than or equal to the limiting length, L_p , lateral torsional buckling does not control and need not be checked. The lateral torsional buckling Eqs. 6.12.2.2.5-2 and 6.12.2.2.5-3 assume that the channel has compact flanges satisfying Eq. 6.12.2.2.5-10 and a compact web satisfying Eq. 6.12.2.2.5-12; hence, flange and web local buckling need not be checked. All rolled channels given in AISC (2005) have compact flanges and webs for $F_y \leq 65$ ksi. Thus, Eqs. 6.12.2.2.5-10 and 6.12.2.2.5-12 need not be checked for rolled channels. To utilize Eqs. 6.12.2.2.5-2 and 6.12.2.2.5-3 for fabricated or bent-plate channels, Eqs. 6.12.2.2.5-10 and 6.12.2.2.5-12 must be satisfied. Eqs. 6.12.2.2.5-2 and 6.12.2.2.5-3 also assume that the channel is restrained at the brace points such that twisting of the member does not occur at those points. For fabricated or bent-plate channels, Eq. 6.12.2.2.5-5 taken from Salmon and Johnson (1996) and Eq. A6.3.3-9 may be used for the computation of C_w and J , respectively. For rolled channels, values of the warping torsional constant, C_w , and the St. Venant torsional constant, J , including the effect of the sloping flanges and web-to-flange fillets, are tabulated in AISC (2005a) and may be used in lieu of the values from these equations.

For channels in flexure about their weak or y -axis, the limit of $1.6F_y S_y$ on the nominal flexural resistance is intended to indirectly prevent substantial yielding of the member at service load levels.

$$C_w = \text{warping torsional constant (in.}^6\text{)}$$

$$= \frac{t_f b^3 h_o^2}{12} \left(\frac{3bt_f + 2h_o t_w}{6bt_f + h_o t_w} \right) \quad (6.12.2.2.5-6)$$

$$L_p = \text{limiting unbraced length to achieve the nominal flexural resistance } M_p \text{ under uniform bending (in.)}$$

$$= 1.76 r_y \sqrt{\frac{E}{F_y}} \quad (6.12.2.2.5-7)$$

$$L_r = \text{limiting unbraced length to achieve the nominal onset of yielding under uniform bending with consideration of compression-flange residual stress effects (in.)}$$

$$= 1.95 r_{ts} \frac{E}{0.7F_y} \sqrt{\frac{Jc}{S_x h_o}} \sqrt{1 + \sqrt{1 + 6.76 \left(\frac{0.7F_y}{E} \frac{S_x h_o}{Jc} \right)^2}} \quad (6.12.2.2.5-8)$$

$$r_{ts}^2 = \frac{\sqrt{I_y C_w}}{S_x} \quad (6.12.2.2.5-9)$$

where:

- C_b = moment gradient modifier determined as specified in Article A6.3.3
- L_b = unbraced length (in.)
- b = distance between the toe of the flange and the centerline of the web (in.)
- h_o = distance between flange centroids (in.)
- I_y = moment of inertia about the y -axis (in.⁴)
- J = St. Venant torsional constant (in.⁴)
- r_{ts} = radius of gyration used in the determination of L_r (in.)
- r_y = radius of gyration about the y -axis (in.)
- S_x = elastic section modulus about the x -axis (in.³)
- t_f = thickness of the flange (in.); for rolled channels, use the average thickness
- t_w = thickness of the web (in.)

For channels in flexure about their weak or y -axis, the nominal flexural resistance shall be determined according to the provisions specified in Article 6.12.2.2.1. The nominal flexural resistance shall not exceed $1.6F_y S_y$, where S_y is the elastic section modulus about the y -axis.

The flange slenderness, λ_f , of fabricated or bent-plate channels shall satisfy:

$$\lambda_f \leq \lambda_{pf} \quad (6.12.2.2.5-10)$$

in which:

$$\begin{aligned}\lambda_f &= \text{flange slenderness of the channel} = b_f/t_f \\ \lambda_{pf} &= \text{limiting slenderness for a compact flange}\end{aligned}$$

$$= 0.38 \sqrt{\frac{E}{F_y}} \quad (6.12.2.2.5-11)$$

where:

$$\begin{aligned}b_f &= \text{flange width (in.)} \\ t_f &= \text{flange thickness (in.)}\end{aligned}$$

The web slenderness of fabricated or bent-plate channels shall satisfy:

$$\frac{D}{t_w} \leq \lambda_{pw} \quad (6.12.2.2.5-12)$$

in which:

$$\lambda_{pw} = \text{limiting slenderness for a compact web}$$

$$= 3.76 \sqrt{\frac{E}{F_y}} \quad (6.12.2.2.5-13)$$

where:

$$\begin{aligned}D &= \text{web depth (in.)} \\ t_w &= \text{web thickness (in.)}\end{aligned}$$

6.12.2.2.6—Single Angles

Single angles should not be used as pure flexural members. Single angles subject to combined axial compression and flexure may be designed according to the provisions specified in Article 6.9.4.4.

C6.12.2.2.6

Single angles are not typically intended to serve as pure flexural members in bridge applications. In most practical applications, single angles are subject to flexure about both principal axes due to the eccentricity of applied axial loads. The condition of flexure due to eccentric axial tension is primarily addressed through the use of the shear lag coefficient, U , specified in Article 6.8.2.2. The condition of flexure due to eccentric axial compression may be efficiently handled through the use of an effective slenderness ratio, $(K\ell/r)_{eff}$, as specified in Article 6.9.4.4, which allows single angles satisfying certain specified conditions to be designed as axially loaded compression members for flexural buckling only. Thus, the calculation of the nominal flexural resistance M_n of a single-angle member is typically not required for these common cases. In certain unusual cases discussed in Article C6.9.4.4, single angles subject to combined flexure and axial compression must be evaluated as beam-columns according to the provisions specified in Section H2 of AISC (2005) in lieu of using the effective slenderness ratio. In such cases, M_n of the single angle member may be

determined according to the procedures given in Section F10 of AISC (2005).

6.12.2.2.7—Rectangular Bars and Solid Rounds

For rectangular bars and solid rounds in flexure, the nominal flexural resistance shall be taken as the smaller value based on yielding or lateral torsional buckling, as applicable.

For yielding, the nominal flexural resistance shall be taken as:

- For rectangular bars with $\frac{L_b d}{t^2} \leq \frac{0.08E}{F_y}$ in flexure about their major geometric axis, rectangular bars in flexure about their minor geometric axis, and solid rounds:

$$M_n = M_p = F_y Z \leq 1.6M_y \quad (6.12.2.2.7-1)$$

where:

- d = depth of the rectangular bar (in.)
- F_y = specified minimum yield strength (ksi)
- L_b = unbraced length for lateral displacement or twist, as applicable (in.)
- M_p = plastic moment (kip-in.)
- M_y = yield moment (kip-in.)
- t = width of the rectangular bar parallel to the axis of bending (in.)
- Z = plastic section modulus (in.³)

For lateral torsional buckling, the nominal flexural resistance shall be taken as follows for rectangular bars in flexure about their major geometric axis:

- If $\frac{0.08E}{F_y} < \frac{L_b d}{t^2} \leq \frac{1.9E}{F_y}$, then:

$$M_n = C_b \left[1.52 - 0.274 \left(\frac{L_b d}{t^2} \right) \frac{F_y}{E} \right] M_y \leq M_p \quad (6.12.2.2.7-2)$$

- If $\frac{L_b d}{t^2} > \frac{1.9E}{F_y}$, then:

$$M_n = F_{cr} S_x \leq M_p \quad (6.12.2.2.7-3)$$

in which:

$$F_{cr} = \frac{1.9EC_b}{\frac{L_b d}{t^2}} \quad (\text{ksi})$$

C6.12.2.2.7

These provisions apply to solid bars of round or rectangular cross-section and are taken from AISC (2005). The nominal flexural resistance of these sections will typically be controlled by yielding, except for rectangular bars with a depth larger than the width, which may be controlled by lateral torsional buckling. Since the shape factor for a rectangular cross-section is 1.5 and for a round cross-section is 1.7, the potential for excessive deflections or permanent deformations under service conditions should be considered.

where:

- C_b = moment gradient modifier determined as specified in Article A6.3.3
 S_x = section modulus about the major geometric axis (in.³)

For rectangular bars in flexure about their minor geometric axis and for solid rounds, lateral torsional buckling shall not be considered.

6.12.2.3—Composite Members

6.12.2.3.1—Concrete-Encased Shapes

For concrete-encased shapes that satisfy the provisions of Article 6.9.5.2.3, the nominal resistance of concrete-encased shapes subjected to flexure without compression shall be taken as the lesser of:

$$M_n = M_{ps}, \text{ or} \quad (6.12.2.3.1-1)$$

$$M_n = M_{yc} \quad (6.12.2.3.1-2)$$

For the purpose of Article 6.9.2.2, the nominal flexural resistance of concrete-encased shapes subjected to compression and flexure shall be taken as:

- If $\frac{P_u}{\phi_c P_n} \geq 0.3$, then:

$$M_n = Z F_y + \frac{(d - 2c) A_r F_{yr}}{3} + \left(\frac{d}{2} - \frac{A_w F_y}{1.7 f'_c b} \right) A_w F_y \quad (6.12.2.3.1-3)$$

- If $0.0 < \left(\frac{P_u}{\phi_c P_n} \right) < 0.3$, then:

M_n shall be determined by a linear interpolation between the M_n value given by Eq. 6.12.2.3.1-1 or 6.12.2.3.1-2 at $P_u = 0$ and the M_n value given by Eq. 6.12.2.3.1-3 at $(P_u/\phi_c P_n) \geq 0.3$

where:

- P_u = axial compressive force due to the factored loading (kip)
 P_n = nominal compressive resistance specified in Article 6.9.5.1 (kip)
 ϕ_c = resistance factor for axial compression specified in Article 6.5.4.2
 M_{ps} = plastic moment of the steel section (kip-in.)
 M_{yc} = yield moment of the composite section determined as specified in Article D6.2 (kip-in.)
 Z = plastic section modulus of the steel section about the axis of bending (in.³)

C6.12.2.3.1

The behavior of the concrete-encased shapes and concrete-filled tubes covered in this Article is discussed extensively in Galambos (1998) and AISC (2005). Such members are most often used as columns or beam columns. The provisions for circular concrete-filled tubes also apply to concrete-filled pipes.

The equation for M_n when $(P_u/\phi_c P_n) \geq 0.3$ is an approximate equation for the plastic moment resistance that combines the flexural strengths of the steel shape, the reinforcing bars, and the reinforced concrete. These resistances are defined in the first, second, and third terms of the equation respectively (Galambos, 1998). The equation has been verified by extensive tests (Galambos and Chapuis, 1980).

No test data are available on the loss of bond in composite beam columns. However, consideration of tensile cracking of concrete suggests $(P_u/\phi_c P_n) = 0.3$ as a conservative limit (AISC, 1999). It is assumed that when $(P_u/\phi_c P_n)$ is less than 0.3, the nominal flexural resistance is reduced below the plastic moment resistance of the composite section given by Eq. 6.12.2.3.1-3.

When there is no axial load, even with full encasement, it is assumed that the bond is only capable of developing the lesser of the plastic moment resistance of the steel section or the yield moment resistance of the composite section.

- A_w = web area of the steel section (in.²)
 f'_c = specified minimum 28-day compressive strength of the concrete (ksi)
 A_r = area of the longitudinal reinforcement (in.²)
 c = distance from the center of the longitudinal reinforcement to the nearest face of the member in the plane of flexure (in.)
 d = depth of the member in the plane of flexure (in.)
 b = width of the member perpendicular to the plane of flexure (in.)
 F_{yr} = specified minimum yield strength of the longitudinal reinforcement (ksi)

6.12.2.3.2—Concrete-Filled Tubes

The nominal flexural resistance of concrete-filled tubes that satisfy the limitations in Articles 6.9.5.2 may be taken as:

- If $\frac{D}{t} < 2.0 \sqrt{\frac{E}{F_y}}$, then:

$$M_n = M_{ps} \quad (6.12.2.3.2-1)$$

- If $2.0 \sqrt{\frac{E}{F_y}} < \frac{D}{t} \leq 8.8 \sqrt{\frac{E}{F_y}}$, then:

$$M_n = M_{yc} \quad (6.12.2.3.2-2)$$

C6.12.2.3.2

Eqs. 6.12.2.3.2-1 and 6.12.2.3.2-2 represent a step function for nominal flexural resistance. No accepted transition equation is available at this writing.

6.12.3—Nominal Shear Resistance of Composite Members

6.12.3.1—Concrete-Encased Shapes

The nominal shear resistance may be taken as:

$$V_n = 0.58F_{yw}Dt_w + \frac{F_{yr}A_v(d-c)}{s} \quad (6.12.3.1-1)$$

where:

- F_{yw} = specified minimum yield strength of the web of the steel shape (ksi)
 F_{yr} = specified minimum yield strength of the transverse reinforcement (ksi)
 D = web depth of the steel shape (in.)
 t_w = thickness of the web or webs of the steel shape (in.)
 A_v = cross-sectional area of transverse reinforcement bars that intercept a diagonal shear crack (in.²)
 s = longitudinal spacing of transverse reinforcement (in.)
 d = depth of the member in the plane of shear (in.)
 c = distance from the center of the longitudinal reinforcement to the nearest face of the member in the plane of bending (in.)

6.12.3.2—Concrete-Filled Tubes*6.12.3.2.1—Rectangular Tubes*

The nominal shear resistance may be taken as:

$$V_n = 1.16D t_w F_y \quad (6.12.3.2.1-1)$$

where:

D = web depth of the tube (in.)
 t_w = wall thickness of the tube (in.)

6.12.3.2.2—Circular Tubes

The nominal shear resistance may be taken as:

V_n = nominal shear resistance of the steel tube alone (kip)

6.13—CONNECTIONS AND SPLICES**6.13.1—General**

Except as specified otherwise, connections and splices for primary members shall be designed at the strength limit state for not less than the larger of:

- The average of the flexural moment-induced stress, shear, or axial force due to the factored loadings at the point of splice or connection and the factored flexural, shear, or axial resistance of the member or element at the same point, or
- 75 percent of the factored flexural, shear, or axial resistance of the member or element.

Where diaphragms, cross-frames, lateral bracing, stringers, or floorbeams for straight or horizontally curved flexural members are included in the structural model used to determine force effects, or alternatively, are designed for explicitly calculated force effects from the results of a separate investigation, end connections for these bracing members shall be designed for the calculated factored member force effects. Otherwise, the end connections for these members shall be designed according to the 75 percent resistance provision contained herein.

Insofar as practicable, connections should be made symmetrical about the axis of the members. Connections, except for lacing bars and handrails, shall contain not less than two bolts. Members, including bracing, should be connected so that their gravity axes will intersect at a point. Eccentric connections should be avoided. Where eccentric connections cannot be avoided, members and connections shall be proportioned for the combined effects of shear and moment due to the eccentricity.

In the case of connections that transfer total member end shear, the gross section shall be taken as the gross section of the connected elements.

C6.13.1

Where a section changes at a splice, the smaller section is to be used for these requirements. These requirements are retained from AASHTO (2002).

The exception for bracing members for straight or horizontally curved flexural members that are included in the structural model used to determine force effects results from experience with details developed invoking the 75 percent and average load provisions herein. These details tended to become so large as to be unwieldy resulting in large eccentricities and force concentrations. It has been decided that the negatives associated with these connections justifies the exception permitted herein.

The thickness of end connection angles of stringers, floorbeams and girders shall not be less than 0.375 in. End connections for stringers, floorbeams and girders should be made with two angles. Bracket or shelf angles that may be used to furnish support during erection shall not be considered in determining the number of fasteners required to transmit end shear.

Unless otherwise permitted by the contract documents, standard-size bolt holes shall be used in connections in horizontally curved bridges.

End connections of stringers, floorbeams, and girders should be bolted with high-strength bolts. Welded connections may be permitted when bolting is not practical. Where used, welded end connections shall be designed for vertical loads and the bending moment resulting from the restraint against end rotation.

Where timber stringers frame into steel floorbeams, shelf angles with stiffeners shall be provided to support the total reaction. Shelf angles shall not be less than 0.4375 in. thick.

6.13.2—Bolted Connections

6.13.2.1—General

Bolted steel parts may be coated or uncoated and shall fit solidly together after the bolts are tightened. The contract documents shall specify that all joint surfaces, including surfaces adjacent to the bolt head and nut, shall be specified to be free of scale, except tight mill scale, and free of dirt or other foreign material.

High-strength bolted joints shall be designated as either slip-critical or bearing-type connections. For slip-critical connections, the friction value shall be consistent with the specified condition of the faying surfaces as specified in Article 6.13.2.8. All material within the grip of the bolt shall be steel.

6.13.2.1.1—Slip-Critical Connections

Joints subject to stress reversal, heavy impact loads, severe vibration or located where stress and strain due to joint slippage would be detrimental to the serviceability of the structure shall be designated as slip-critical. They include:

- Joints subject to fatigue loading;
- Joints in shear with bolts installed in oversized holes;
- Joints in shear with bolts installed in short- and long-slotted holes where the force on the joint is in a direction other than perpendicular to the axis of the slot, except where the Engineer intends otherwise and so indicates in the contract documents;
- Joints subject to significant load reversal;

Standard-size bolt holes in connections in horizontally curved bridges ensure that the steel fits together in the field.

C6.13.2.1.1

In bolted slip-critical connections subject to shear, the load is transferred between the connected parts by friction up to a certain level of force that is dependent upon the total clamping force on the faying surfaces and the coefficient of friction of the faying surfaces. The connectors are not subject to shear nor is the connected material subject to bearing stress. As loading is increased to a level in excess of the frictional resistance between the faying surfaces, slip occurs, but failure in the sense of rupture does not occur. As a result, slip-critical connections are able to resist even greater loads by shear and bearing against the connected material. The strength of the connection is not related to the slip load. These Specifications require that the slip resistance and the shear and bearing resistance be computed separately. Because

- Joints in which welds and bolts share in transmitting load at a common faying surface;
- Joints in axial tension or combined axial tension and shear;
- Joints in axial compression only, with standard or slotted holes in only one ply of the connection with the direction of the load perpendicular to the direction of the slot, except for connections designed according to the provisions specified in Article 6.13.6.1.3; and
- Joints in which, in the judgment of the Engineer, any slip would be critical to the performance of the joint or the structure and which are so designated in the contract documents.

Slip-critical connections shall be proportioned to prevent slip under Load Combination Service II, as specified in Table 3.4.1-1, and to provide bearing, shear, and tensile resistance at the applicable strength limit state load combinations. The provisions of Article 6.13.2.2 apply.

6.13.2.1.2—Bearing-Type Connections

Bearing-type connections shall be permitted only for joints subjected to axial compression or joints on bracing members and shall satisfy the factored resistance, R_r , at the strength limit state.

6.13.2.2—Factored Resistance

For slip-critical connections, the factored resistance, R_r , of a bolt at the Service II Load Combination shall be taken as:

$$R_r = R_n \quad (6.13.2.2-1)$$

where:

R_n = nominal resistance as specified in Article 6.13.2.8

The factored resistance, R_r or T_r , of a bolted connection at the strength limit state shall be taken as either:

$$R_r = \phi R_n \quad (6.13.2.2-2)$$

$$T_r = \phi T_n \quad (6.13.2.2-3)$$

the combined effect of frictional resistance with shear or bearing has not been systematically studied and is uncertain, any potential greater resistance due to combined effect is ignored.

For slotted holes, perpendicular to the slot is defined as an angle between approximately 80 to 100 degrees to the axis of the slot.

The intent of this provision is to control permanent deformations under overloads caused by slip in joints that could adversely affect the serviceability of the structure. The provisions are intended to apply to the design live load specified in Article 3.6.1.1. If this criterion were to be applied to a permit load situation, a reduction in the load factor for live load should be considered. Slip-critical connections must also be checked for the strength load combinations in Table 3.4.1-1, assuming that the connection has slipped at these high loads and gone into bearing against the connected material.

C6.13.2.1.2

In bolted bearing-type connections, the load is resisted by shear in the fastener and bearing upon the connected material, plus some uncertain amount of friction between the faying surfaces. The final failure will be by shear failure of the connectors, by tear out of the connected material, or by unacceptable ovalization of the holes. Final failure load is independent of the clamping force provided by the bolts (Kulak et al., 1987).

C6.13.2.2

Eq. 6.13.2.2-1 applies to a service limit state for which the resistance factor is 1.0, and, hence, is not shown in the equation.

where:

R_n = nominal resistance of the bolt, connection, or connected material as follows:

- For bolts in shear, R_n shall be taken as specified in Article 6.13.2.7
- For the connected material in bearing joints, R_n shall be taken as specified in Article 6.13.2.9
- For connected material in tension or shear, R_n shall be taken as specified in Article 6.13.5

T_n = nominal resistance of a bolt as follows:

- For bolts in axial tension, T_n shall be taken as specified in Article 6.13.2.10
- For bolts in combined axial tension and shear, T_n shall be taken as specified in Article 6.13.2.11

ϕ = resistance factor for bolts specified in Article 6.5.4.2, taken as:

- ϕ_s for bolts in shear,
- ϕ_t for bolts in tension,
- ϕ_{bb} for bolts bearing on material,
- ϕ_y or ϕ_u for connected material in tension, as appropriate, or
- ϕ_v or ϕ_{vu} for connected material in shear.

6.13.2.3—Bolts, Nuts, and Washers

6.13.2.3.1—Bolts and Nuts

The provisions of Article 6.4.3 shall apply.

6.13.2.3.2—Washers

Washers used in bolted connections shall satisfy the requirements specified in Article 6.4.3. Hardened washers for high-strength bolted connections shall be required where:

- The outer face of the bolted parts has a slope greater than 1:20, with respect to a plane normal to the bolt axis;
- Tightening is to be performed by the calibrated wrench method, in which case the washer shall be used under the element turned in tightening;
- AASHTO M 253 (ASTM A490) bolts are to be installed in material having a specified minimum yield strength less than 50.0 ksi, irrespective of the tightening method;
- Needed for oversize or slotted holes according to the provisions specified herein;

C6.13.2.3.2

Proper location of hardened washers is as important to the performance of the bolts as other elements of a detail. Drawings and details should clearly reflect the number and disposition of washers, especially the washers that are required for slotted-hole applications.

- AASHTO M 253 (ASTM A490) bolts over 1.0 in. in diameter are to be installed in an oversize or short-slotted hole in an outer-ply, in which case a minimum thickness of 0.3125 in. shall be used under both the head and the nut. Multiple hardened washers shall not be used.

Hardened washers shall be installed over oversize and short-slotted holes in an outer ply.

Structural plate washers or a continuous bar with standard holes, not less than 0.3125 in. in thickness, shall be required to completely cover long-slotted holes. Hardened washers for use with high-strength bolts shall be placed over the outer surface of the plate washer or bar.

Load indicator devices shall not be installed over oversize or slotted holes in an outer ply, unless a hardened washer or a structural plate washer is also provided.

6.13.2.4—Holes

6.13.2.4.1—Type

6.13.2.4.1a—General

Unless specified otherwise, standard holes shall be used in high-strength bolted connections.

6.13.2.4.1b—Oversize Holes

Oversize holes may be used in any or all plies of slip-critical connections. They shall not be used in bearing-type connections.

6.13.2.4.1c—Short-Slotted Holes

Short-slotted holes may be used in any or all plies of slip-critical or bearing-type connections. The slots may be used without regard to direction of loading in slip-critical connections, but the length shall be normal to the direction of the load in bearing-type connections.

6.13.2.4.1d—Long-Slotted Holes

Long-slotted holes may be used in only one ply of either a slip-critical or bearing-type connection. Long-slotted holes may be used without regard to direction of loading in slip-critical connections but shall be normal to the direction of load in bearing-type connections.

6.13.2.4.2—Size

The dimension of the holes shall not exceed the values given in Table 6.13.2.4.2-1.

Table 6.13.2.4.2-1—Maximum Hole Sizes

Bolt Dia.	Standard	Oversize	Short Slot	Long Slot
d	Dia.	Dia.	Width \times Length	Width \times Length
in.	in.	in.	in.	in.
5/8	11/16	13/16	11/16 \times 7/8	11/16 \times 1-9/16
3/4	13/16	15/16	13/16 \times 1	13/16 \times 1-7/8
7/8	15/16	1-1/16	15/16 \times 1-1/8	15/16 \times 2-3/16
1	1-1/16	1-1/4	1-1/16 \times 1-5/16	1-1/16 \times 2-1/2
$\geq 1-1/8$	$d+1/16$	$d+5/16$	$d+1/16 \times d+3/8$	$d+1/16 \times 2.5d$

6.13.2.5—Size of Bolts

Bolts shall not be less than 0.625 in. in diameter. Bolts 0.625 in. in diameter shall not be used in primary members, except in 2.5-in. legs of angles and in flanges of sections whose dimensions require 0.625-in. fasteners to satisfy other detailing provisions herein. Use of structural shapes that do not allow the use of 0.625-in. fasteners shall be limited to handrails.

Angles whose size is not determined by a calculated demand may use:

- 0.625-in. diameter bolts in 2.0-in. legs,
- 0.75-in. diameter bolts in 2.5-in. legs,
- 0.875-in. diameter bolts in 3.0-in. legs, and
- 1.0-in. diameter bolts in 3.5-in. legs.

The diameter of bolts in angles of primary members shall not exceed one-fourth the width of the leg in which they are placed.

6.13.2.6—Spacing of Bolts

6.13.2.6.1—Minimum Spacing and Clear Distance

The minimum spacing between centers of bolts in standard holes shall be no less than three times the diameter of the bolt. When oversize or slotted holes are used, the minimum clear distance between the edges of adjacent bolt holes in the direction of the force and transverse to the direction of the force shall not be less than twice the diameter of the bolt.

6.13.2.6.2—Maximum Spacing for Sealing Bolts

For sealing against the penetration of moisture in joints, the spacing on a single line adjacent to a free edge of an outside plate or shape shall satisfy:

$$s \leq (4.0 + 4.0t) \leq 7.0 \quad (6.13.2.6.2-1)$$

C6.13.2.6.1

In uncoated weathering steel structures, pack-out is not expected to occur in joints where bolts satisfy the maximum spacing requirements specified in Article 6.13.2.6.2 (Brockenbrough, 1983).

If there is a second line of fasteners uniformly staggered with those in the line adjacent to the free edge, at a gage less than $1.5 + 4.0t$, the staggered spacing, s , in two such lines, considered together, shall satisfy:

$$s \leq 4.0 + 4.0t - \left(\frac{3.0g}{4.0} \right) \leq 7.0 \quad (6.13.2.6.2-2)$$

The staggered spacing need not be less than one-half the requirement for a single line.

where:

t = thickness of the thinner outside plate or shape (in.)

g = gage between bolts (in.)

6.13.2.6.3—Maximum Pitch for Stitch Bolts

C6.13.2.6.3

Stitch bolts shall be used in mechanically fastened builtup members where two or more plates or shapes are in contact.

The pitch of stitch bolts in compression members shall not exceed $12.0t$. The gage, g , between adjacent lines of bolts shall not exceed $24.0t$. The staggered pitch between two adjacent lines of staggered holes shall satisfy:

$$p \leq 15.0t - \left(\frac{3.0g}{8.0} \right) \leq 12.0t \quad (6.13.2.6.3-1)$$

The intent of this provision is to ensure that the parts act as a unit and, in compression members, prevent buckling.

The pitch for tension members shall not exceed twice that specified herein for compression members. The gage for tension members shall not exceed $24.0t$. The maximum pitch of fasteners in mechanically fastened builtup members shall not exceed the lesser of the requirements for sealing or stitch.

6.13.2.6.4—Maximum Pitch for Stitch Bolts at the End of Compression Members

The pitch of bolts connecting the component parts of a compression member shall not exceed four times the diameter of the fastener for a length equal to 1.5 times the maximum width of the member. Beyond this length, the pitch may be increased gradually over a length equal to 1.5 times the maximum width of the member until the maximum pitch specified in Article 6.13.2.6.3 is reached.

6.13.2.6.5—End Distance

The end distance for all types of holes measured from the center of the bolt shall not be less than the edge distances specified in Table 6.13.2.6.6-1. When oversize or slotted holes are used, the minimum clear end distance shall not be less than the bolt diameter.

The maximum end distance shall be the maximum edge distance as specified in Article 6.13.2.6.6.

6.13.2.6.6—Edge Distances

The minimum edge distance shall be as specified in Table 6.13.2.6.6-1.

The maximum edge distance shall not be more than eight times the thickness of the thinnest outside plate or 5.0 in.

Table 6.13.2.6.6-1—Minimum Edge Distances

Bolt Diameter	Sheared Edges	Rolled Edges of Plates or Shapes, or Gas Cut Edges
in.	in.	in.
5/8	1-1/8	7/8
3/4	1-1/4	1
7/8	1-1/2	1-1/8
1	1-3/4	1-1/4
1-1/8	2	1-1/2
1-1/4	2-1/4	1-5/8
1-3/8	2-3/8	1-3/4

6.13.2.7—Shear Resistance

The nominal shear resistance of a high-strength bolt (ASTM A325 or ASTM A490) or an ASTM A307 bolt (Grade A or B) at the strength limit state in joints whose length between extreme fasteners measured parallel to the line of action of the force is less than 50.0 in. shall be taken as:

- Where threads are excluded from the shear plane:

$$R_n = 0.48A_b F_{ub} N_s \quad (6.13.2.7-1)$$

- Where threads are included in the shear plane:

$$R_n = 0.38A_b F_{ub} N_s \quad (6.13.2.7-2)$$

where:

- A_b = area of the bolt corresponding to the nominal diameter (in.²)
- F_{ub} = specified minimum tensile strength of the bolt specified in Article 6.4.3 (ksi)
- N_s = number of shear planes per bolt

The nominal shear resistance of a bolt in connections greater than 50.0 in. in length shall be taken as 0.80 times the value given by Eq. 6.13.2.7-1 or 6.13.2.7-2.

In determining whether the bolt threads are excluded from the shear planes of the contact surfaces, the thread length of the bolt shall be determined as two thread pitch lengths greater than the specified thread length.

C6.13.2.7

The nominal resistance in shear is based upon the observation that the shear strength of a single high-strength bolt is about 0.60 times the tensile strength of that bolt (Kulak et al., 1987). However, in shear connections with more than two bolts in the line of force, deformation of the connected material causes nonuniform bolt shear force distribution so that the strength of the connection in terms of the average bolt strength decreases as the joint length increases. Rather than provide a function that reflects this decrease in average fastener strength with joint length, a single reduction factor of 0.80 was applied to the 0.60 multiplier. This accommodates bolts in joints up to 50.0 in. in length without seriously affecting the economy of very short joints. The nominal shear resistance of bolts in joints longer than 50.0 in. must be further reduced by an additional 20 percent. Studies have shown that the allowable stress factor of safety against shear failure ranges from 3.3 for compact, i.e., short, joints to approximately 2.0 for joints with an overall length in excess of 50.0 in. It is of interest to note that the longest and often the most important joints had the lowest factor, indicating that a factor of safety of 2.0 has proven satisfactory in service (Kulak et al., 1987). For flange splices, the 50.0-in. length is to be measured between the extreme bolts on only one side of the connection.

The average value of the nominal resistance for bolts with threads in the shear plane has been determined by a series of tests to be 0.833 ($0.6F_{ub}$), with a standard deviation of 0.03 (Yura et al., 1987). A value of about 0.80

If the threads of a bolt are included in the shear plane in the joint, the shear resistance of the bolt in all shear planes of the joint shall be the value for threads included in the shear plane.

For ASTM A307 bolts, shear design shall be based on Eq. 6.13.2.7-2. When the grip length of an ASTM A307 bolt exceeds 5.0 diameters, the nominal resistance shall be lowered one percent for each 1/16 in. of grip in excess of 5.0 diameters.

6.13.2.8—Slip Resistance

The nominal slip resistance of a bolt in a slip-critical connection shall be taken as:

$$R_n = K_h K_s N_s P_t \quad (6.13.2.8-1)$$

where:

- N_s = number of slip planes per bolt
- P_t = minimum required bolt tension specified in Table 6.13.2.8-1 (kip)
- K_h = hole size factor specified in Table 6.13.2.8-2
- K_s = surface condition factor specified in Table 6.13.2.8-3

Table 6.13.2.8-1—Minimum Required Bolt Tension

Bolt Diameter, in.	Required Tension- P_t (kip)	
	M 164 (A325)	M 253 (A490)
5/8	19	24
3/4	28	35
7/8	39	49
1	51	64
1-1/8	56	80
1-1/4	71	102
1-3/8	85	121
1-1/2	103	148

was selected for the specification formula based upon the area corresponding to the nominal body area of the bolt.

The shear strength of bolts is not affected by pretension in the fasteners, provided that the connected material is in contact at the faying surfaces.

The factored resistance equals the nominal shear resistance multiplied by a resistance factor less than that used to determine the factored resistance of a component. This ensures that the maximum strength of the bridge is limited by the strength of the main members rather than by the connections.

The absence of design strength provisions specifically for the case where a bolt in double shear has a nonthreaded shank in one shear plane and a threaded section in the other shear plane is because of the uncertainty of manner of sharing the load between the two shear areas. It also recognizes that knowledge about the bolt placement, which might leave both shear planes in the threaded section, is not ordinarily available to the designer.

The threaded length of an ASTM A307 bolt is not as predictable as that of a high-strength bolt. The requirement to use Eq. 6.13.2.7-2 reflects that uncertainty.

ASTM A307 bolts with a long grip tend to bend, thus reducing their resistance.

C6.13.2.8

Extensive data developed through research has been statistically analyzed to provide improved information on slip probability of connections in which the bolts have been preloaded to the requirements of Table 6.13.2.8-1. Two principal variables, bolt pretension and coefficient of friction, i.e., the surface condition factor of the faying surfaces, were found to have the greatest effect on the slip resistance of connections.

Hole size factors less than 1.0 are provided for bolts in oversize and slotted holes because of their effects on the induced tension in bolts using any of the specified installation methods. In the case of bolts in long-slotted holes, even though the slip load is the same for bolts loaded transverse or parallel to the axis of the slot, the values for bolts loaded parallel to the axis have been further reduced, based upon judgment, because of the greater consequences of slip.

The criteria for slip resistance are for the case of connections subject to a coaxial load. For cases in which the load tends to rotate the connection in the plane of the faying surface, a modified formula accounting for the placement of bolts relative to the center of rotation should be used (Kulak et al., 1987).

The required tension specified for AASHTO M 164 (ASTM A325) bolts larger than M24 reflects an update from the ISO specification that lists identical material properties for the size range from M16 to M36. This update has not yet been applied to the customary U.S. Specifications.

Table 6.13.2.8-2—Values of K_h

For standard holes	1.00
For oversize and short-slotted holes	0.85
For long-slotted holes with the slot perpendicular to the direction of the force	0.70
For long-slotted holes with the slot parallel to the direction of the force	0.60

Table 6.13.2.8-3—Values of K_s

For Class A surface conditions	0.33
For Class B surface conditions	0.50
For Class C surface conditions	0.33

The following descriptions of surface condition shall apply to Table 6.13.2.8-3:

- Class A Surface: unpainted clean mill scale, and blast-cleaned surfaces with Class A coatings,
- Class B Surface: unpainted blast-cleaned surfaces and blast-cleaned surfaces with Class B coatings, and
- Class C Surface: hot-dip galvanized surfaces roughened by wire brushing after galvanizing.

The contract documents shall specify that in uncoated joints, paint, including any inadvertent overspray, be excluded from areas closer than one bolt diameter but not less than 1.0 in. from the edge of any hole and all areas within the bolt pattern.

The contract documents shall specify that joints having painted faying surfaces be blast-cleaned and coated with a paint that has been qualified by test as a Class A or Class B coating.

The minimum bolt tension values given in Table 6.13.2.8-1 are equal to 70 percent of the minimum tensile strength of the bolts. The same percentage of the tensile strength has been traditionally used for the required tension of the bolts.

The effect of ordinary paint coatings on limited portions of the contact area within joints and the effect of overspray over the total contact area have been investigated experimentally (Polyzois and Frank, 1986). The tests demonstrated that the effective area for transfer of shear by friction between contact surfaces was concentrated in an annular ring around and close to the bolts. Paint on the contact surfaces approximately 1.0 in., but not less than the bolt diameter away from the edge of the hole did not reduce the slip resistance. On the other hand, bolt pretension might not be adequate to completely flatten and pull thick material into tight contact around every bolt. Therefore, these Specifications require that all areas between bolts also be free of paint.

On clean mill scale, this research found that even the smallest amount of overspray of ordinary paint, i.e., a coating not qualified as Class A, within the specified paint-free area, reduced the slip resistance significantly. On blast-cleaned surfaces, the presence of a small amount of overspray was not as detrimental. For simplicity, these Specifications prohibit any overspray from areas required to be free of paint in slip-critical joints, regardless of whether the surface is clean mill scale or blast-cleaned.

The mean value of slip coefficients from many tests on clean mill scale, blast-cleaned steel surfaces and galvanized and roughened surfaces were taken as the basis for the three classes of surfaces. As a result of research by Frank and Yura (1981), a test method to determine the slip coefficient for coatings used in bolted joints was developed (AISC, 1994). The method includes long-term creep test requirements to ensure reliable performance for

Subject to the approval of the Engineer, coatings providing a surface condition factor less than 0.33 may be used, provided that the mean surface condition factor is established by test. The nominal slip resistance shall be determined as the nominal slip resistance for Class A surface conditions, as appropriate for the hole and bolt type, times the surface condition factor determined by test divided by 0.33.

The contract documents shall specify that:

- Coated joints not be assembled before the coatings have cured for the minimum time used in the qualifying test, and
- Faying surfaces specified to be galvanized shall be hot-dip galvanized in accordance with AASHTO M 111M/M 111 (ASTM A123/A123M). The surfaces shall subsequently be roughened by means of hand-wire brushing. Power-wire brushing shall not be permitted.

If a slip-critical connection is subject to an applied tensile force that reduces the net clamping force, the nominal slip resistance shall be multiplied by the factor specified by Eq. 6.13.2.11-3.

qualified paint coatings. The method, which requires requalification if an essential variable is changed, is the sole basis for qualification of any coating to be used under these Specifications. Further, normally only two categories of surface conditions for paints to be used in slip-critical joints are recognized: Class A for coatings that do not reduce the slip coefficient below that provided by clean mill scale, and Class B for paints that do not reduce the slip coefficient below that of blast-cleaned steel surfaces.

To cover those cases where a coefficient of friction less than 0.33 might be adequate, the Specification provides that, subject to the approval of the Engineer, and provided that the mean slip coefficient is determined by the specified test procedure, faying surface coatings providing lower slip resistance than Class A coating may be used. It should be noted that both Class A and Class B coatings are required to be applied to blast-cleaned steel.

The research cited in the preceding paragraph also investigated the effect of varying the time from coating the faying surfaces to assembly to ascertain if partially cured paint continued to cure. It was found that all curing ceased at the time the joint was assembled and tightened and that paint coatings that were not fully cured acted as lubricant. Thus, the slip resistance of the joint was severely reduced.

On galvanized faying surfaces, research has shown that the slip factor of galvanized surfaces is significantly improved by treatments, such as hand wire brushing or light "brush-off" grit blasting (Birkemoe and Herrschaft, 1970). In either case, the treatment must be controlled in order to achieve the necessary roughening or scoring. Power wire brushing is unsatisfactory because it tends to polish rather than roughen the surface.

Tests on surfaces that were wire-brushed after galvanizing have indicated an average value of the slip coefficient equal to 0.35 (Kulak et al., 1987). Untreated surfaces with normal zinc have much smaller slip coefficients. Even though the slip coefficient for Class C surfaces is the same as for Class A surfaces, a separate class is retained to avoid potential confusion. The higher value of the slip coefficient equal to 0.40 in previous specifications assumes that the surface has been blast-cleaned after galvanizing, which is not the typical practice. Field experience and test results have indicated that galvanized members may have a tendency to continue to slip under sustained loading (Kulak et al., 1987). Tests of hot-dip galvanized joints subject to sustained loading show a creep-type behavior. Treatments to the galvanized faying surfaces prior to assembly of the joint that caused an increase in the slip resistance under short-duration loads did not significantly improve the slip behavior under sustained loading.

Where hot-dip galvanized coatings are used, and especially if the joint consists of many plies of thickly coated material, relaxation of bolt tension may be significant and may require retensioning of the bolts subsequent to the initial tightening. This loss may be allowed for in design or pretensioning may be brought back

6.13.2.9—Bearing Resistance at Bolt Holes

The effective bearing area of a bolt shall be taken as its diameter multiplied by the thickness of the connected material on which it bears. The effective thickness of connected material with countersunk holes shall be taken as the thickness of the connected material, minus one-half the depth of the countersink.

For standard holes, oversize holes, short-slotted holes loaded in any direction, and long-slotted holes parallel to the applied bearing force, the nominal resistance of interior and end bolt holes at the strength limit state, R_n , shall be taken as:

- With bolts spaced at a clear distance between holes not less than $2.0d$ and with a clear end distance not less than $2.0d$:

$$R_n = 2.4dtF_u \quad (6.13.2.9-1)$$

- If either the clear distance between holes is less than $2.0d$, or the clear end distance is less than $2.0d$:

$$R_n = 1.2L_c t F_u \quad (6.13.2.9-2)$$

For long-slotted holes perpendicular to the applied bearing force:

- With bolts spaced at a clear distance between holes not less than $2.0d$ and with a clear end distance not less than $2.0d$:

$$R_n = 2.0dtF_u \quad (6.13.2.9-3)$$

- If either the clear distance between holes is less than $2.0d$, or the clear end distance is less than $2.0d$:

$$R_n = L_c t F_u \quad (6.13.2.9-4)$$

where:

- d = nominal diameter of the bolt (in.)
- t = thickness of the connected material (in.)
- F_u = tensile strength of the connected material specified in Table 6.4.1-1 (ksi)

to the prescribed level by a retightening of the bolts after an initial period of “settling-in.”

While slip-critical connections with bolts pretensioned to the levels specified in Table 6.13.2.8-1 do not ordinarily slip into bearing when subject to anticipated loads, it is required that they meet the requirements of Article 6.13.2.7 and Article 6.13.2.9 in order to maintain a factor of safety of 2.0, if the bolts slip into bearing as a result of large, unforeseen loads.

C6.13.2.9

Bearing stress produced by a high-strength bolt pressing against the side of the hole in a connected part is important only as an index to behavior of the connected part. Thus, the same bearing resistance applies regardless of bolt shear strength or the presence or absence of threads in the bearing area. The critical value can be derived from the case of a single bolt at the end of a tension member.

Using finger-tight bolts, it has been shown that a connected plate will not fail by tearing through the free edge of the material if the distance L , measured parallel to the line of applied force from a single bolt to the free edge of the member toward which the force is directed, is not less than the diameter of the bolt multiplied by the ratio of the bearing stress to the tensile strength of the connected part (Kulak et al., 1987).

The criterion for nominal bearing strength is:

$$\frac{L}{d} \geq \frac{r_n}{F_u} \quad (C6.13.2.9-1)$$

where:

- r_n = nominal bearing pressure (ksi)
- F_u = specified minimum tensile strength of the connected part (ksi)

In these Specifications, the nominal bearing resistance of an interior hole is based on the clear distance between the hole and the adjacent hole in the direction of the bearing force. The nominal bearing resistance of an end hole is based on the clear distance between the hole and the end of the member. The nominal bearing resistance of the connected member may be taken as the sum of the resistances of the individual holes. The clear distance is used to simplify the computations for oversize and slotted holes.

Holes may be spaced at clear distances less than the specified values, as long as the lower value specified by Eq. 6.13.2.9-2 or Eq. 6.13.2.9-4, as applicable, is used for the nominal bearing resistance.

L_c = clear distance between holes or between the hole and the end of the member in the direction of the applied bearing force (in.)

6.13.2.10—Tensile Resistance

6.13.2.10.1—General

High-strength bolts subjected to axial tension shall be tensioned to the force specified in Table 6.13.2.8-1. The applied tensile force shall be taken as the force due to the external factored loadings, plus any tension resulting from prying action produced by deformation of the connected parts, as specified in Article 6.13.2.10.4.

6.13.2.10.2—Nominal Tensile Resistance

The nominal tensile resistance of a bolt, T_n , independent of any initial tightening force shall be taken as:

$$T_n = 0.76A_b F_{ub} \quad (6.13.2.10.2-1)$$

where:

A_b = area of bolt corresponding to the nominal diameter (in.²)

F_{ub} = specified minimum tensile strength of the bolt specified in Article 6.4.3 (ksi)

6.13.2.10.3—Fatigue Resistance

Where high-strength bolts in axial tension are subject to fatigue, the stress range, Δf , in the bolt, due to the fatigue design live load, plus the dynamic load allowance for fatigue loading specified in Article 3.6.1.4, plus the prying force resulting from cyclic application of the fatigue load, shall satisfy Eq. 6.6.1.2.2-1.

The nominal diameter of the bolt shall be used in calculating the bolt stress range. In no case shall the calculated prying force exceed 30 percent of the externally applied load.

Low carbon ASTM A307 bolts shall not be used in connections subjected to fatigue.

6.13.2.10.4—Prying Action

The tensile force due to prying action shall be taken as:

$$Q_u = \left[\frac{3b}{8a} - \frac{t^3}{20} \right] P_u \quad (6.13.2.10.4-1)$$

where:

Q_u = prying tension per bolt due to the factored loadings taken as 0 when negative (kip)

C6.13.2.10.2

The recommended design strength is approximately equal to the initial tightening force; thus, when loaded to the service load, high-strength bolts will experience little, if any, actual change in stress. For this reason, bolts in connections, in which the applied loads subject the bolts to axial tension, are required to be fully tensioned.

C6.13.2.10.3

Properly tightened A325 and A490 bolts are not adversely affected by repeated application of the recommended service load tensile stress, provided that the fitting material is sufficiently stiff that the prying force is a relatively small part of the applied tension. The provisions covering bolt tensile fatigue are based upon study of test reports of bolts that were subjected to repeated tensile load to failure (Kulak et al., 1987).

C6.13.2.10.4

Eq. 6.13.2.10.4-1 for estimating the magnitude of the force due to prying is a simplification given in ASCE (1971) of a semiempirical expression (Douty and McGuire, 1965). This simplified formula tends to overestimate the prying force and provides conservative design results (Nair et al., 1974).

- P_u = direct tension per bolt due to the factored loadings (kip)
 a = distance from center of bolt to edge of plate (in.)
 b = distance from center of bolt to the toe of fillet of connected part (in.)
 t = thickness of thinnest connected part (in.)

6.13.2.11—Combined Tension and Shear

The nominal tensile resistance of a bolt subjected to combined shear and axial tension, T_n , shall be taken as:

- If $\frac{P_u}{R_n} \leq 0.33$, then:

$$T_n = 0.76 A_b F_{ub} \quad (6.13.2.11-1)$$

- Otherwise:

$$T_n = 0.76 A_b F_{ub} \sqrt{1 - \left(\frac{P_u}{\phi_s R_n} \right)^2} \quad (6.13.2.11-2)$$

where:

- A_b = area of the bolt corresponding to the nominal diameter (in.²)
 F_{ub} = specified minimum tensile strength of the bolt specified in Article 6.4.3 (ksi)
 P_u = shear force on the bolt due to the factored loads (kip)
 R_n = nominal shear resistance of a bolt specified in Article 6.13.2.7 (kip)

The nominal resistance of a bolt in slip-critical connections under Load Combination Service II, specified in Table 3.4.1-1, subjected to combined shear and axial tension, shall not exceed the nominal slip resistance specified in Article 6.13.2.8 multiplied by:

$$1 - \frac{T_u}{P_t} \quad (6.13.2.11-3)$$

where:

- T_u = tensile force due to the factored loads under Load Combination Service II (kip)
 P_t = minimum required bolt tension specified in Table 6.13.2.8-1 (kip)

6.13.2.12—Shear Resistance of Anchor Bolts

The nominal shear resistance of an ASTM F1554 or an ASTM A307 Grade C anchor bolt at the strength limit state shall be taken as:

- Where threads are included in the shear plane:

C6.13.2.11

The nominal tensile resistance of bolts subject to combined axial tension and shear is provided by elliptical interaction curves, which account for the connection length effect on bolts loaded in shear, the ratio of shear strength to tension strength of threaded bolts, and the ratios of root area to nominal body area and tensile stress area to nominal body area (Chesson et al., 1965). Eqs. 6.13.2.11-1 and 6.13.2.11-2 are conservative simplifications of the set of elliptical curves. The equations representing the set of elliptical curves for various cases may be found in AISC (1988). No reduction in the nominal tensile resistance is required when the applied shear force on the bolt due to the factored loads is less than or equal to 33 percent of the nominal shear resistance of the bolt.

C6.13.2.12

Conditions typically exist in connections with anchor bolts such that the full resistance of each bolt is probably not entirely utilized when resisting applied shear forces. Oversize holes and other factors tend to cause nonuniformity in anchor bolt stresses and thus, connection

$$R_n = 0.48 A_b F_{ub} N_s \quad (6.13.2.12-1)$$

where:

- A_b = area of the anchor bolt corresponding to the nominal diameter (in.²)
 F_{ub} = specified minimum tensile strength of the anchor bolt specified in Article 6.4.3 (ksi)
 N_s = number of shear planes per anchor bolt

inefficiency. Due to these effects, a reduction factor of 0.8 should be applied to the 0.48 multiplier for Eq. 6.13.2.12-1 as appropriate.

See Article C6.13.2.7 for further commentary on strength reduction factors.

For global design of anchorages to concrete, refer to *Building Code Requirements for Structural Concrete* (ACI 318-05), Appendix D.

6.13.3—Welded Connections

6.13.3.1—General

Base metal, weld metal, and welding design details shall conform to the requirements of the *AASHTO/AWS D1.5M/D1.5 Bridge Welding Code*. Welding symbols shall conform to those specified in AWS Publication A2.4.

Matching weld metal shall be used in groove and fillet welds, except that the Engineer may specify electrode classifications with strengths less than the base metal when detailing fillet welds, in which case the welding procedure and weld metal shall be selected to ensure sound welds.

6.13.3.2—Factored Resistance

6.13.3.2.1—General

The factored resistance of welded connections, R_r , at the strength limit state shall be taken as specified in Articles 6.13.3.2.2 through 6.13.3.2.4.

The effective area of the weld shall be taken as specified in Article 6.13.3.3. The factored resistance of the connection material shall be taken as specified in Article 6.13.5.

6.13.3.2.2—Complete Penetration Groove-Welded Connections

6.13.3.2.2a—Tension and Compression

The factored resistance of complete penetration groove-welded connections subjected to tension or compression normal to the effective area or parallel to the axis of the weld shall be taken as the factored resistance of the base metal.

6.13.3.2.2b—Shear

The factored resistance of complete penetration groove-welded connections subjected to shear on the effective area shall be taken as the lesser of the value given by Eq. 6.13.3.2.2b-1 or 60 percent of the factored resistance of the base metal in tension:

C6.13.3.1

Use of undermatched weld metal is highly encouraged for fillet welds connecting steels with specified minimum yield strength greater than 50 ksi. Research has shown that undermatched welds are much less sensitive to delayed hydrogen cracking and are more likely to produce sound welds on a consistent basis.

C6.13.3.2.1

The factored resistance of a welded connection is governed by the resistance of the base metal or the deposited weld metal. The nominal resistance of fillet welds is determined from the effective throat area, whereas the nominal strength of the connected parts is governed by their respective thickness.

The classification strength of the weld metal can conservatively be taken as the classification number, EXX. The letters XX stand for the minimum strength levels of the electrodes in ksi.

C6.13.3.2.2a

In groove welds, the maximum forces are usually tension or compression. Tests have shown that groove welds of the same thickness as the connected parts are adequate to develop the factored resistance of the connected parts.

$$R_r = 0.6\phi_{e1}F_{exx} \quad (6.13.3.2.2b-1)$$

where:

F_{exx} = classification strength of the weld metal (ksi)
 ϕ_{e1} = resistance factor for the weld metal specified in Article 6.5.4.2

6.13.3.2.3—Partial Penetration Groove-Welded Connections

6.13.3.2.3a—Tension or Compression

C6.13.3.2.3a

The factored resistance of partial penetration groove-welded connections subjected to tension or compression parallel to the axis of the weld or compression normal to the effective area shall be taken as the factored resistance of the base metal.

The factored resistance for partial penetration groove-welded connections subjected to tension normal to the effective area shall be taken as the lesser of either the value given by either Eq. 6.13.3.2.3a-1 or the factored resistance of the base metal:

For restrictions on the use of partial penetration groove welds in this application, see Article 6.6.1.2.4.

$$R_r = 0.6\phi_{e1}F_{exx} \quad (6.13.3.2.3a-1)$$

where:

ϕ_{e1} = resistance factor for the weld metal specified in Article 6.5.4.2

6.13.3.2.3b—Shear

The factored resistance of partial penetration groove-welded connections subjected to shear parallel to the axis of the weld shall be taken as the lesser of either the factored nominal resistance of the connected material specified in Article 6.13.5 or the factored resistance of the weld metal taken as:

$$R_r = 0.6\phi_{e2}F_{exx} \quad (6.13.3.2.3b-1)$$

where:

ϕ_{e2} = resistance factor for the weld metal as specified in Article 6.5.4.2

6.13.3.2.4—Fillet-Welded Connections

6.13.3.2.4a—Tension and Compression

C6.13.3.2.4a

The factored resistance for fillet-welded connections subjected to tension or compression parallel to the axis of the weld shall be taken as the factored resistance of the base metal.

Flange-to-web fillet-welded connections may be designed without regard to the tensile or compressive stress in those elements parallel to the axis of the welds.

6.13.3.2.4b—Shear

The resistance of fillet welds in shear which are made with matched or undermatched weld metal and which have typical weld profiles shall be taken as the product of the effective area specified in Article 6.13.3.3 and the factored resistance of the weld metal taken as:

$$R_r = 0.6\phi_{e2}F_{exc} \quad (6.13.3.2.4b-1)$$

6.13.3.3—Effective Area

The effective area shall be the effective weld length multiplied by the effective throat. The effective throat shall be the shortest distance from the joint root to the weld face.

6.13.3.4—Size of Fillet Welds

The size of a fillet weld that may be assumed in the design of a connection shall be such that the forces due to the factored loadings do not exceed the factored resistance of the connection specified in Article 6.13.3.2.

The maximum size of fillet weld that may be used along edges of connected parts shall be taken as:

- For material less than 0.25 in. thick: the thickness of the material, and
- For material 0.25 in. or more in thickness: 0.0625 in. less than the thickness of the material, unless the weld is designated on the contract documents to be built out to obtain full throat thickness.

C6.13.3.2.4b

The factored resistance of fillet welds subjected to shear along the length of the weld is dependent upon the strength of the weld metal and the direction of applied load, which may be parallel or transverse to the weld. In both cases, the weld fails in shear, but the plane of rupture is not the same. Shear yielding is not critical in welds because the material strain hardens without large overall deformations occurring. Therefore, the factored shear resistance is based on the shear strength of the weld metal multiplied by a suitable resistance factor to ensure that the connected part will develop its full strength without premature failure of the weldment.

If fillet welds are subjected to eccentric loads that produce a combination of shear and bending stresses, they must be proportioned on the basis of a direct vector addition of the shear forces on the weld.

It is seldom that weld failure will ever occur at the weld leg in the base metal. The applicable effective area for the base metal is the weld leg which is 30 percent greater than the weld throat. If overstrength weld metal is used or the weld throat has excessive convexity, the capacity can be governed by the weld leg and the shear fracture resistance of the base metal $0.6 F_u$.

C6.13.3.3

Additional requirements can be found in the *AASHTO/AWS D1.5M/D1.5 Bridge Welding Code*, Article 2.3.

C6.13.3.4

The minimum size of fillet weld should be taken as specified in Table 6.13.3.4-1. The weld size need not exceed the thickness of the thinner part joined. Smaller fillet welds may be approved by the Engineer based upon applied stress and the use of the appropriate preheat.

Table 6.13.3.4-1—Minimum Size of Fillet Welds

Base Metal Thickness of Thicker Part Joined (T)	Minimum Size of Fillet Weld
in.	in.
$T \leq 3/4$	1/4
$3/4 < T$	5/16

6.13.3.5—Minimum Effective Length of Fillet Welds

The minimum effective length of a fillet weld shall be four times its size and in no case less than 1.5 in.

6.13.3.6—Fillet Weld End Returns

Fillet welds that resist a tensile force not parallel to the axis of the weld or that are not proportioned to withstand repeated stress shall not terminate at corners of parts or members. Where such returns can be made in the same plane, they shall be returned continuously, full size, around the corner, for a length equal to twice the weld size. End returns shall be indicated in the contract documents.

Fillet welds deposited on the opposite sides of a common plane of contact between two parts shall be interrupted at a corner common to both welds.

6.13.3.7—Seal Welds

Seal welds should be a continuous weld combining the functions of sealing and strength, changing section only as required by strength or the requirements for minimum size fillet weld.

6.13.4—Block Shear Rupture Resistance

The web connection of coped beams and all tension connections, including connection plates, splice plates and gusset plates, shall be investigated to ensure that adequate connection material is provided to develop the factored resistance of the connection.

The connection shall be investigated by considering all possible failure planes in the member and connection plates. Such planes shall include those parallel and perpendicular to the applied forces. The planes parallel to the applied force shall be considered to resist only shear stresses. The planes perpendicular to the applied force shall be considered to resist only tension stresses.

The factored resistance of the combination of parallel and perpendicular planes shall be taken as:

The requirements for minimum size of fillet welds are based upon the quench effect of thick material on small welds, not on strength considerations. Very rapid cooling of weld metal may result in a loss of ductility. Further, the restraint to weld metal shrinkage provided by thick material may result in weld cracking. A 0.3125-in. fillet weld is the largest that can be deposited in a single pass by manual process, but minimum preheat and interpass temperatures are to be provided.

C6.13.3.6

End returns should not be provided around transverse stiffeners.

C6.13.4

Block shear rupture is one of several possible failure modes for splices, connections, and gusset plates. Investigation of other failure modes and critical sections is still required, e.g., a net section extending across the full plate width, and, therefore, having no parallel planes, may be a more severe requirement for a girder flange or splice plate than the block shear rupture mode. The provisions of Articles 6.13.5, 6.13.6 and 6.14.2.8 should be consulted.

Tests on coped beams have indicated that a tearing failure mode can occur along the perimeter of the bolt holes (Birkemoe and Gilmour, 1978). This block shear failure mode is one in which the resistance is determined by the sum of the nominal shear resistance on a failure path(s) and the nominal tensile resistance on a perpendicular segment. The failure path is defined by the

$$R_r = \phi_{bs} R_p (0.58 F_u A_{vn} + U_{bs} F_u A_m) \leq \phi_{bs} R_p (0.58 F_y A_{vg} + U_{bs} F_u A_m) \quad (6.13.4-1)$$

where:

- R_p = reduction factor for holes taken equal to 0.90 for bolt holes punched full size and 1.0 for bolt holes drilled full size or subpunched and reamed to size
- A_{vg} = gross area along the plane resisting shear stress (in.²)
- A_{vn} = net area along the plane resisting shear stress (in.²)
- U_{bs} = reduction factor for block shear rupture resistance taken equal to 0.50 when the tension stress is non-uniform and 1.0 when the tension stress is uniform
- A_m = net area along the plane resisting tension stress (in.²)
- F_y = specified minimum yield strength of the connected material (ksi)
- F_u = specified minimum tensile strength of the connected material specified in Table 6.4.1-1 (ksi)
- ϕ_{bs} = resistance factor for block shear specified in Article 6.5.4.2

The gross area shall be determined as the length of the plane multiplied by the thickness of the component. The net area shall be the gross area, minus the number of whole or fractional holes in the plane, multiplied by the nominal hole diameter specified in Table 6.13.2.4.2-1 times the thickness of the component.

In determining the net section of cuts carrying tension stress, the effect of staggered holes adjacent to the cuts shall be determined in accordance with Article 6.8.3. For net sections carrying shear stress, the full effective diameter of holes centered within two diameters of the cut shall be deducted. Holes further removed may be disregarded.

6.13.5—Connection Elements

6.13.5.1—General

This Article shall be applied to the design of connection elements such as splice plates, gusset plates, corner angles, brackets, and lateral connection plates in tension or shear, as applicable.

6.13.5.2—Tension

The factored resistance, R_r , in tension shall be taken as the least of the values given by either Eqs. 6.8.2.1-1 and 6.8.2.1-2 for yielding and fracture, respectively, or the block shear rupture resistance specified in Article 6.13.4.

In determining P_{nu} , as specified in Eq. 6.8.2.1-2, for lateral connection plates, splice plates, and gusset plates, the reduction factor, U , specified in Article 6.8.2.2, shall

centerlines of the bolt holes. The block shear rupture mode is not limited to the coped ends of beams. Tension member connections are also susceptible. The block shear rupture mode should also be checked around the periphery of welded connections.

A conservative model has been adopted to predict the block shear rupture resistance in which the resistance to rupture along the shear plane is added to the resistance to rupture on the tensile plane. Block shear is a rupture or tearing phenomenon and not a yielding phenomenon. However, gross yielding along the shear plane can occur when tearing on the tensile plane commences if $0.58 F_u A_{vn}$ exceeds $0.58 F_y A_{vg}$. Therefore, Eq. 6.13.4-1 limits the term $0.58 F_u A_{vn}$ to not exceed $0.58 F_y A_{vg}$. Eq. 6.13.4-1 is consistent with the philosophy for tension members where the gross area is used for yielding and the net area is used for rupture.

In certain cases, e.g., coped beam connections with multiple rows of bolts, the tensile stress on the end plane is nonuniform because the rows of bolts nearest the beam end pick up most of the shear (Ricles and Yura, 1983; Kulak and Grondin, 2001). Therefore, a reduction factor, U_{bs} , has been included in Eq. 6.13.4-1 to approximate the effect of the non-uniform stress distribution on the tensile plane in such cases. For the majority of connections encountered in steel bridges, U_{bs} will equal 1.0. The reduction factor, R_p , conservatively accounts for the reduced rupture resistance in the vicinity of bolt holes that are punched full size (Brown et al. 2007), as discussed further in Article C6.8.2.1.

C6.13.5.2

Because the length of the lateral connection plate, splice plate, or gusset plate is small compared to the member length, inelastic deformation of the gross section is limited. Hence,

be taken to be equal to 1.0, and the net area of the plate, A_n , used in Eq. 6.8.2.1-2, shall not be taken as greater than 85 percent of the gross area of the plate.

the net area of the connecting element is limited to $0.85A_g$ in recognition of the limited inelastic deformation and to provide a reserve capacity (Kulak et al., 1987).

6.13.5.3—Shear

The factored shear resistance, R_r , of the connection element shall be taken as the smaller value based on shear yielding or shear rupture.

For shear yielding, the factored shear resistance of the connection element shall be taken as:

$$R_r = \phi_v 0.58 F_y A_{vg} \quad (6.13.5.3-1)$$

where:

A_{vg} = gross area of the connection element subject to shear (in.²)

F_y = specified minimum yield strength of the connection element (ksi)

ϕ_v = resistance factor for shear as specified in Article 6.5.4.2

For shear rupture, the factored shear resistance, R_r , of the connection element shall be taken as:

$$R_r = \phi_{vu} 0.58 R_p F_u A_{vn} \quad (6.13.5.3-2)$$

where:

A_{vn} = net area of the connection element subject to shear (in.²)

F_u = tensile strength of the connection element (ksi)

R_p = reduction factor for holes taken equal to 0.90 for bolt holes punched full size and 1.0 for bolt holes drilled full size or subpunched and reamed to size

ϕ_{vu} = resistance factor for shear rupture of connection elements as specified in Article 6.5.4.2

6.13.6—Splices

6.13.6.1—Bolted Splices

6.13.6.1.1—General

Bolted splices shall be designed at the strength limit state to satisfy the requirements specified in Article 6.13.1. Where a section changes at a splice, the smaller of the two connected sections shall be used in the design.

6.13.6.1.2—Tension Members

Splices for tension members shall satisfy the requirements specified in Article 6.13.5.2. Splices for tension members shall be designed using slip-critical connections as specified in Article 6.13.2.1.1.

6.13.6.1.3—Compression Members

Splices for compression members detailed with milled ends in full contact bearing at the splices and for which the contract documents specify inspection during fabrication and erection, may be proportioned for not less than 50 percent of the lower factored resistance of the sections spliced.

Splices in truss chords, arch members, and columns should be located as near to the panel points as practicable and usually on that side where the smaller force effect occurs. The arrangement of plates, angles, or other splice elements shall be such as to make proper provision for all force effects in the component parts of the members spliced.

6.13.6.1.4—Flexural Members

6.13.6.1.4a—General

In continuous spans, splices should be made at or near points of dead load contraflexure. Web and flange splices in areas of stress reversal shall be investigated for both positive and negative flexure.

In both web and flange splices, there shall not be less than two rows of bolts on each side of the joint. Oversize or slotted holes shall not be used in either the member or the splice plates at bolted splices.

Bolted splices for flexural members shall be designed using slip-critical connections as specified in Article 6.13.2.1.1. The connections shall also be proportioned to prevent slip during the erection of the steel and during the casting of the concrete deck.

The factored flexural resistance of the flanges at the point of splice at the strength limit state shall satisfy the applicable provisions of Article 6.10.6.2.

The flexural stresses due to the factored loads at the strength limit state and for checking slip of the bolted connections at the point of splice shall be determined using the gross section properties.

Bolted flange angle splices shall include two angles, one on each side of the flexural member.

C6.13.6.1.3

This is consistent with the provisions of past editions of the Standard Specifications which permitted up to 50 percent of the force in a compression member to be carried through a splice by bearing on milled ends of components.

C6.13.6.1.4a

For a flexural member, it is recommended that the smaller section at the point of splice be taken as the side of the splice that has the smaller calculated moment of inertia for the noncomposite steel section.

Bolted splices located in regions of stress reversal near points of dead load contraflexure must be checked for both positive and negative flexure to determine the governing condition.

To ensure proper alignment and stability of the girder during construction, web and flange splices are not to have less than two rows of bolts on each side of the joint. Also, oversize or slotted holes are not permitted in either the member or the splice plates at bolted splices of flexural members for improved geometry control during erection and because a strength reduction may occur when oversize or slotted holes are used in eccentrically loaded bolted web connections.

Also, for improved geometry control, bolted connections for both web and flange splices are to be proportioned to prevent slip under the maximum actions induced during the erection of the steel and during the casting of the concrete deck.

At the following sections with holes in the tension flange:

- Compact composite sections in positive flexure in straight bridges,
- Straight composite I-sections in negative flexure or straight noncomposite I-sections with compact or noncompact webs designed according to the provisions of Appendix A6,

for which the nominal flexural resistance is permitted to exceed the moment at first yield at the strength limit state, it has not yet been fully documented that complete plastification of the cross-section can occur

prior to fracture on the net section of the tension flange. Furthermore, the splice design provisions of this Article do not consider the contribution of substantial web yielding to the flexural resistance of the sections listed above. Therefore, the factored flexural resistance of the tension flange at cross-sections with holes at the strength limit state or for constructibility is conservatively limited to be less than or equal to the specified minimum yield stress of the tension flange according to the provisions of Article 6.10.1.8. As a result, this requirement will likely prevent bolted splices from being located in these sections at or near points of maximum applied moment where significant yielding of the web, beyond the localized yielding of the web permitted in hybrid members, is allowed at the strength limit state.

Splices for flexural members have typically been designed in the past by treating the flanges and web of the girder as individual components and then proportioning a calculated design moment for the splice to each component. However, for composite sections, superposition of moments does not apply when at elastic stress levels because the moments are applied to different sections, whereas superposition of stresses is valid. Thus, the use of flexural stresses to compute the actions necessary to design the splice is preferred.

Fatigue of the base metal adjacent to the slip-critical connections in the splice plates may be checked as specified in Table 6.6.1.2.3-1 using the gross section of the splice plates and member. However, the areas of the flange and web splice plates will often equal or exceed the areas of the flange and web to which they are attached. The flanges and web are checked separately for either equivalent or more critical fatigue category details. Therefore, fatigue will generally not govern the design of the splice plates.

6.13.6.1.4b—Web Splices

Web splice plates and their connections shall be designed for shear, the moment due to the eccentricity of the shear at the point of splice and the portion of the flexural moment assumed to be resisted by the web at the point of splice. For all single box sections, and for multiple box sections in bridges not satisfying the requirements of Article 6.11.2.3, including horizontally curved bridges, or with box flanges that are not fully effective according to the provisions of Article 6.11.1.1, the shear shall be taken as the sum of the flexural and St. Venant torsional shears in the web subjected to additive shears. For boxes with inclined webs, the web splice shall be designed for the component of the vertical shear in the plane of the web.

As a minimum, at the strength limit state, the design shear, V_{uw} , shall be taken as follows:

C6.13.6.1.4b

Eqs. 6.13.6.1.4b-1 and 6.13.6.1.4b-2 provide a more consistent design shear to be used for designing web splice plates and their connections at the strength limit state than that given in past editions of the Standard Specifications and the First Edition of the LRFD Specifications. Eq. 6.13.6.1.4b-1 arbitrarily limits the increase in the shear at the point of splice to 50 percent of the shear due to the factored loading, V_u , where V_u is less than 50 percent of the factored shear resistance, $V_r = \phi_v V_n$, at the point of splice. The increase in the shear is limited to 50 percent of V_u because the possibilities for V_u to change from its calculated value are less than for moment; large unintended shifts in the shear at the splice are unlikely. In addition, the maximum shear is usually not concurrent with the maximum moment at the splice. Thus, the use of a lower value of the design shear in regions where the applied shear is low is deemed reasonable. A lower value of the design shear is also more

- If $V_u < 0.5\phi_v V_n$, then:

$$V_{uw} = 1.5V_u \quad (6.13.6.1.4b-1)$$

- Otherwise:

$$V_{uw} = \frac{(V_u + \phi_v V_n)}{2} \quad (6.13.6.1.4b-2)$$

where:

- ϕ_v = resistance factor for shear specified in Article 6.5.4.2
- V_u = shear due to the factored loading at the point of splice (kip)
- V_n = nominal shear resistance determined as specified in Articles 6.10.9.2 and 6.10.9.3 for unstiffened and stiffened webs, respectively (kip)

The design shear at the strength limit state shall not exceed the lesser of the factored shear resistance of the web splice plates specified in Article 6.13.4 or the factored shear resistance of the web splice plates specified in Article 6.13.5.3.

The eccentricity of the design shear shall be taken as the distance from the centerline of the splice to the centroid of the connection on the side of the joint under consideration.

At the strength limit state, the combined flexural and axial stress in the web splice plates shall not exceed the specified minimum yield strength of the splice plates times the resistance factor, ϕ_f , specified in Article 6.5.4.2.

Bolted connections for web splices shall be designed as slip-critical connections for the maximum resultant bolt design force. As a minimum, for checking slip of the web splice bolts, the design shear shall be taken as the shear at the point of splice under Load Combination Service II, as specified in Table 3.4.1-1.

Webs shall be spliced symmetrically by plates on each side. The splice plates shall extend as near as practical for the full depth between flanges.

reasonable for rolled beams, which have significantly higher values of factored shear resistance. For cases where V_u is greater than 50 percent of V_r , the design shear is determined from Eq. 6.13.6.1.4b-2 as the average of V_u and V_r . For checking slip of the bolted connections, the design shear is simply taken as the shear at the point of splice under Load Combination Service II defined in Table 3.4.1-1. The web with the smallest nominal shear resistance on either side of the splice should be used to determine the design shear.

Web splices are also to be designed for the moment due to the eccentricity of the design shear. The eccentricity is explicitly defined as the distance from the centerline of the splice to the centroid of the connection on the side of the joint under consideration rather than the distance between the centroids of the connections on each side of the joint (Sheikh-Ibrahim and Frank, 1998).

Many different approaches have been used to determine the proportion of the total flexural moment carried by the web at the point of splice, which have not always led to consistent results. For reasons discussed below, it is suggested that the portion of the flexural moment assumed to be resisted by the web be applied at the middepth of the web. As a result, at sections where the neutral axis is not at the middepth of the web, a horizontal force resultant must also be applied at the middepth of the web to establish equilibrium. This horizontal force resultant may be assumed distributed equally to all web bolts. The following equations are suggested to determine a design moment, M_{uw} , and a design horizontal force resultant, H_{uw} , to be applied at the middepth of the web for designing the web splice plates and their connections at the strength limit state:

$$M_{uw} = \frac{t_w D^2}{12} |R_h F_{cf} - R_{cf} f_{ncf}| \quad (C6.13.6.1.4b-1)$$

$$H_{uw} = \frac{t_w D}{2} (R_h F_{cf} + R_{cf} f_{ncf}) \quad (C6.13.6.1.4b-2)$$

where:

- t_w = web thickness of the smaller section at the point of splice (in.)
- D = web depth of the smaller section at the point of splice (in.)
- R_h = hybrid factor specified in Article 6.10.1.10.1. For hybrid sections in which F_{cf} does not exceed the specified minimum yield strength of the web, the hybrid factor shall be taken as 1.0
- F_{cf} = design stress for the controlling flange at the point of splice specified in Article 6.13.6.1.4c; positive for tension, negative for compression (ksi)
- R_{cf} = the absolute value of the ratio of F_{cf} to the maximum flexural stress, f_{cf} , due to the factored loads at the midthickness of the controlling flange at the point of splice, as defined in Article 6.13.6.1.4c

f_{ncf} = flexural stress due to the factored loads at the midthickness of the noncontrolling flange at the point of splice concurrent with f_{cf} ; positive for tension, negative for compression (ksi)

In Eqs. C6.13.6.1.4b-1 and C6.13.6.1.4b-2, it is suggested that M_{uw} and H_{uw} be computed by conservatively using the stresses at the midthickness of the flanges. By utilizing the stresses at the midthickness of the flanges, the same stress values can be used for the design of both the web and flange splices, which simplifies the calculations. As an alternate, however, the stresses at the inner fibers of the flanges can be used. In either case, the stresses are to be computed considering the application of the moments due to the appropriate factored loadings to the respective cross-sections supporting those loadings. In Eqs. C6.13.6.1.4b-1 and C6.13.6.1.4b-2, the concurrent flexural stress at the midthickness of the noncontrolling flange is factored up in the same proportion as the flexural stress in the controlling flange in order to satisfy the general design requirements of Article 6.13.1. The controlling and noncontrolling flanges are defined in Article C6.13.6.1.4c.

The stresses in Eqs. C6.13.6.1.4b-1 and C6.13.6.1.4b-2 are to be taken as signed quantities. For convenience, absolute value signs are applied to the resulting difference of the stresses in Eq. C6.13.6.1.4b-1. In actuality, the sign of M_{uw} corresponds to the sign of the flexural moment for the loading condition under consideration. H_{uw} in Eq. C6.13.6.1.4b-2 is taken as a signed quantity; positive for tension, negative for compression. For sections where the neutral axis is located at the middepth of the web, H_{uw} will equal zero. For all other sections, M_{uw} and H_{uw} applied together will yield a combined stress distribution equivalent to the unsymmetrical stress distribution in the web.

Eqs. C6.13.6.1.4b-1 and C6.13.6.1.4b-2 can also be used to compute values of M_{uw} and H_{uw} to be used when checking for slip of the web bolts. However, the following substitutions must first be made in both equations:

- Replace F_{cf} with the maximum flexural stress, f_s , due to Load Combination Service II at the midthickness of the flange under consideration for the smaller section at the point of splice,
- Replace f_{ncf} with the flexural stress, f_{os} , due to Load Combination Service II at the midthickness of the other flange at the point of splice concurrent with f_s in the flange under consideration, and
- Set the factors R_h and R_{cf} equal to 1.0. It is not necessary to determine a controlling and noncontrolling flange when checking for slip. The same sign convention applies to the stresses.

In areas of stress reversal, M_{uw} and H_{uw} must be computed independently for both positive and negative

flexure in order to determine the governing condition. For web splices not in an area of stress reversal, M_{uw} and H_{uw} need only be computed for the loading condition causing the maximum flexural stress in the controlling flange at the strength limit state or in the flange under consideration for Load Combination Service II.

An alternative approach for compact steel sections whereby all the flexural moment is assumed to be resisted by the flange splices, provided the flanges are capable of resisting the design moment, is presented by Sheikh-Ibrahim and Frank (1998, 2001). This method is only to be applied at the strength limit state; slip of the bolts should still be checked using the conventional approach. Should the flanges not be capable of resisting the full design moment, the web splice is assumed to resist the additional flexural moment in addition to the design shear and the moment due to the eccentricity of the design shear.

For bolt groups subject to eccentric shear, a traditional approach is often used in which the bolt group is subjected to a concentric shear and a centroidal moment. A vector analysis is performed assuming there is no friction, and that the plates and bolts are elastic (AISC, 2001). The use of this traditional elastic approach is preferred over the ultimate strength approach given in AISC (2001), in which an empirical load-deformation relationship of an individual bolt is considered, because it provides a more consistent factor of safety.

To effectively utilize the traditional elastic approach to compute the maximum resultant bolt force, all actions should be applied at the middepth of the web and the polar moment of inertia of the bolt group, I_p , should be computed about the centroid of the connection. Shifting the polar moment of inertia of the bolt group to the neutral axis of the composite section, which is typically not at the middepth of the web, may cause the bolt forces to be underestimated unless the location of the neutral axis is computed from the summation of the stresses due to the appropriate loadings acting on the respective cross-sections supporting the loadings. Therefore, to simplify the computations and avoid possible errors, it is recommended that all calculated actions in the web be applied at the middepth of the web for the design of the splice. For a uniform vertical pitch of the web bolts, the following formula (AISC, 1963), may then be used to compute I_p about the centroid of the connection:

$$I_p = \frac{nm}{12} \left[s^2 (n^2 - 1) + g^2 (m^2 - 1) \right] \quad (\text{C6.13.6.1.4b-3})$$

where:

- m = number of vertical rows of bolts
- n = number of bolts in one vertical row
- s = vertical pitch (in.)
- g = horizontal pitch (in.)

When checking the bearing resistance of the web at bolt holes, the resistance of an outermost hole, calculated using the clear edge distance, can conservatively be checked against the maximum resultant force acting on the extreme bolt in the connection. This check is conservative since the resultant force acts in the direction of an inclined distance that is larger than the clear edge distance. Should the bearing resistance be exceeded, it is recommended that the edge distance be increased slightly in lieu of increasing the number of bolts or thickening the web. Other options would be to calculate the bearing resistance based on the inclined distance or to resolve the resultant force in the direction parallel to the edge distance. In cases where the bearing resistance of the web splice plates controls, the smaller of the clear edge or end distance on the splice plates can be used to compute the bearing resistance of the outermost hole.

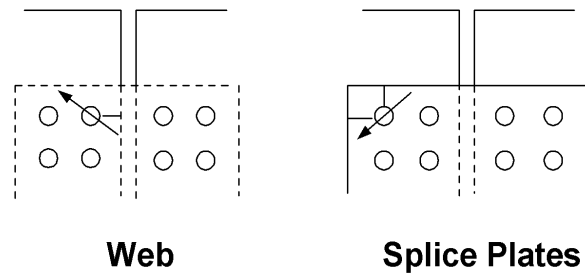

Figure C6.13.6.1.4b-1—Critical Locations for Outermost Holes

Web splice plates are to be symmetrical on each side of the web and are to extend as near as practical to the full depth of the web between flanges without impinging on bolt assembly clearances. The required bolt assembly clearances are given in AISC (2001).

6.13.6.1.4c—Flange Splices

C6.13.6.1.4c

At the strength limit state, splice plates and their connections on the controlling flange shall be proportioned to provide a minimum resistance taken as the design stress, F_{cf} , times the smaller effective flange area, A_e , on either side of the splice, where F_{cf} is defined as:

Eq. 6.13.6.1.4c-1 defines a design stress to be multiplied by the smaller effective flange area on either side of the splice in order to determine a design force for the splice on the controlling flange at the strength limit state.

$$F_{cf} = \frac{\left(\left| \frac{f_{cf}}{R_h} \right| + \alpha \phi_f F_{yf} \right)}{2} \geq 0.75 \alpha \phi_f F_{yf} \tag{6.13.6.1.4c-1}$$

The design stress is based on the general design requirements specified in Article 6.13.1. The use of the effective flange area ensures that fracture on the net section of the tension flange will theoretically be prevented at the splice. The smaller value of the effective flange area on either side of the splice is used to determine the flange design force to ensure that the design force does not exceed the factored resistance of the smaller flange.

in which:

The controlling flange is defined as either the top or bottom flange for the smaller section at the point of splice, whichever flange has the maximum ratio of the elastic flexural stress at its midthickness due to the factored loads for the loading condition under investigation to its factored flexural resistance. The other flange is termed the

A_e = effective area of the flange (in.²). For compression flanges, A_e shall be taken as the gross area of the flange. For tension flanges, A_e shall be taken as:

$$A_e = \left(\frac{\phi_u F_u}{\phi_y F_{yt}} \right) A_n \leq A_g \quad (6.13.6.1.4c-2)$$

where:

- f_{cf} = maximum flexural stress due to the factored loads at the midthickness of the controlling flange at the point of splice (ksi)
- R_h = hybrid factor specified in Article 6.10.1.10.1. For hybrid sections in which F_{cf} does not exceed the specified minimum yield strength of the web, the hybrid factor shall be taken as 1.0
- α = 1.0, except that a lower value equal to (F_n/F_{yf}) may be used for flanges where F_n is less than F_{yf}
- ϕ_f = resistance factor for flexure specified in Article 6.5.4.2
- F_n = nominal flexural resistance of the flange (ksi)
- F_{yf} = specified minimum yield strength of the flange (ksi)
- ϕ_u = resistance factor for fracture of tension members as specified in Article 6.5.4.2
- ϕ_y = resistance factor for yielding of tension members as specified in Article 6.5.4.2
- A_n = net area of the tension flange determined as specified in Article 6.8.3 (in.²)
- A_g = gross area of the tension flange (in.²)
- F_u = specified minimum tensile strength of the tension flange determined as specified in Table 6.4.1-1 (ksi)
- F_{yt} = specified minimum yield strength of the tension flange (ksi)

Splice plates and their connections on the noncontrolling flange at the strength limit state shall be proportioned to provide a minimum resistance taken as the design stress, F_{ncf} , times the smaller effective flange area, A_e , on either side of the splice, where F_{ncf} is defined as:

$$F_{ncf} = R_{cf} \left| \frac{f_{ncf}}{R_h} \right| \geq 0.75\alpha\phi_f F_{yf} \quad (6.13.6.1.4c-3)$$

where:

- R_{cf} = the absolute value of the ratio of F_{cf} to f_{cf} for the controlling flange
- f_{ncf} = flexural stress due to the factored loads at the midthickness of the noncontrolling flange at the point of splice concurrent with f_{cf} (ksi)
- R_h = hybrid factor specified in Article 6.10.1.10.1. For hybrid sections in which F_{cf} does not exceed the specified minimum yield strength of the web, the hybrid factor shall be taken as 1.0

At the strength limit state, the design force in splice plates subjected to tension shall not exceed the factored

noncontrolling flange. In areas of stress reversal, the splice must be checked independently for both positive and negative flexure. For composite sections in positive flexure, the controlling flange is typically the bottom flange. For sections in negative flexure, either flange may qualify as the controlling flange.

The factor α in Eq. 6.13.6.1.4c-1 is generally taken as 1.0, except that a lower value equal to the ratio of F_n to F_{yf} may be used for flanges where F_n is less than F_{yf} . Potential cases include bottom flanges of I-sections in compression, or bottom box flanges in compression or tension at the point of splice. In these cases, the calculated F_n of the flange at the splice may be significantly below F_{yf} making it overly conservative to use F_{yf} in Eq. 6.13.6.1.4c-1 to determine the flange design force for designing the splice. For I-section flanges in compression, the reduction in F_n below F_{yf} is typically not as large as for box flanges. Thus, for simplicity, a conservative value of α equal to 1.0 may be used for this case even though the specification would permit the use of a lower value.

Eq. 6.13.6.1.4c-3 defines a design stress for the noncontrolling flange at the strength limit state. In Eq. 6.13.6.1.4c-3, the flexural stress at the midthickness of the noncontrolling flange, concurrent with the stress in the controlling flange, is factored up in the same proportion as the flexural stress in the controlling flange in order to satisfy the general design requirements of Article 6.13.1. However, as a minimum, the factored-up stress must be equal to or greater than $0.75\alpha\phi_f F_{yf}$.

Eq. 6.13.6.1.4c-5 defines a design stress to be used to compute a flange design force for checking slip of the bolts under Load Combination Service II given in Table 3.4.1-1. Since net section fracture is not a concern when checking for slip under this load combination, the smaller gross flange area on either side of the splice is used to compute the design force. When checking the slip resistance, the use of a Class B surface condition is recommended unless:

- Class A coatings are applied,
- Unpainted clean mill scale is left on the faying surface, or
- The coating has not been properly tested to show conformance with the requirements for Class B coatings.

Since flanges of hybrid sections are allowed to reach F_{yf} , the applied flexural stress at the midthickness of the flange in Eqs. 6.13.6.1.4c-1, 6.13.6.1.4c-3, and 6.13.6.1.4c-5 is divided by the hybrid factor, R_h , instead of reducing F_{yf} by R_h . In actuality, yielding in the web results in an increase in the applied flange stress. When the flange design stress is less than or equal to the specified minimum yield strength of the web, R_h is taken equal to 1.0 since there is theoretically no yielding in the web. The load shedding factor, R_b , is not included in these equations since the presence of the web splice plates precludes the possibility of local web buckling.

resistance in tension specified in Article 6.13.5.2. The design force in splice plates subjected to compression shall not exceed the factored resistance, R_r , in compression taken as:

$$R_r = \phi_c F_y A_s \quad (6.13.6.1.4c-4)$$

where:

- ϕ_c = resistance factor for compression as specified in Article 6.5.4.2
 F_y = specified minimum yield strength of the splice plate (ksi)
 A_s = gross area of the splice plate (in.²)

Bolted connections for flange splices shall be designed as slip-critical connections for the flange design force. As a minimum, for checking slip of the flange splice bolts, the design force for the flange under consideration shall be taken as the Service II design stress, F_s , times the smaller gross flange area on either side of the splice, where F_s is taken as:

$$F_s = \frac{f_s}{R_h} \quad (6.13.6.1.4c-5)$$

where:

- f_s = maximum flexural stress due to Load Combination Service II at the midthickness of the flange under consideration for the smaller section at the point of splice (ksi)
 R_h = hybrid factor specified in Article 6.10.1.10.1. For hybrid sections in which f_s in the flange with the larger stress does not exceed the specified minimum yield strength of the web, the hybrid factor shall be taken as 1.0

Where filler plates are required, the provisions of Article 6.13.6.1.5 shall apply.

For all single box sections, and for multiple box sections in bridges not satisfying the requirements of Article 6.11.2.3, including horizontally curved bridges, or with box flanges that are not fully effective according to the provisions of Article 6.11.1.1, longitudinal warping stresses due to cross-section distortion shall be considered when checking bolted flange splices for slip and for fatigue. Longitudinal warping stresses may be ignored at the strength limit state. St. Venant torsional shear shall also be considered in the design of box-flange bolted splices for these sections at all limit states.

Where applicable, lateral bending effects in discretely braced top flanges of tub sections and in discretely braced flanges of I-sections shall be considered in the design of the bolted flange splices.

Flange splice plates subjected to tension are to be checked for yielding on the gross section, fracture on the net section, and block shear rupture at the strength limit state according to the provisions of Article 6.13.5.2. Block shear rupture will usually not govern the design of splice plates of typical proportion. Flange splice plates subjected to compression at the strength limit state are to be checked only for yielding on the gross section of the plates according to Eq. 6.13.6.1.4c-4. Eq. 6.13.6.1.4c-4 assumes an unbraced length of zero for the splice plates.

For a flange splice with inner and outer splice plates, the flange design force at the strength limit state may be assumed divided equally to the inner and outer plates and their connections when the areas of the inner and outer plates do not differ by more than ten percent. For this case, the connections would be proportioned assuming double shear. Should the areas of the inner and outer plates differ by more than ten percent, the design force in each splice plate and its connection at the strength limit state should instead be determined by multiplying the flange design force by the ratio of the area of the splice plate under consideration to the total area of the inner and outer splice plates. For this case, the shear resistance of the connection would be checked for the maximum calculated splice-plate force acting on a single shear plane. When checking for slip of the connection for a flange splice with inner and outer splice plates, the slip resistance should always be determined by dividing the flange design force equally to the two slip planes regardless of the ratio of the splice plate areas. Slip of the connection cannot occur unless slip occurs on both planes.

For the box sections cited in this Article, including sections in horizontally curved bridges, longitudinal warping stresses due to cross-section distortion can be significant under construction and service conditions and must therefore be considered when checking the connections of bolted flange splices for slip and for fatigue. The warping stresses in these cases can typically be ignored in checking the top-flange splices once the flange is continuously braced. The warping stresses can also be ignored when checking splices in both the top and bottom flanges at the strength limit state. For these sections, St. Venant torsional shear must also be considered in the design of box-flange bolted splices at all limit states. St. Venant torsional shears are typically neglected in top flanges of tub sections once the flanges are continuously braced. The bolts for box-flange splices may be designed for the effects of the torsional shear using the traditional elastic vector method that is typically applied in the design of web splices. Depending on the limit state under investigation, the shear on the flange bolt group is assumed caused by either the flange force due to the factored loads, or by the appropriate flange design force, as applicable. The moment on the bolt group is taken as the moment resulting from the eccentricity of the St. Venant torsional shear due to the factored loads, assumed applied at the centerline of the

splice. At the strength limit state, the torsional shear due to the factored loads need not be multiplied by the factor, R_{cf} , from Eq. 6.13.6.1.4c-3 when computing the moment for the design of the splice. The box-flange splice plates in these cases should also be designed at the strength limit state for the combined effects of the appropriate flange force and the moment resulting from the eccentricity of the St. Venant torsional shear due to the factored loads.

In cases for straight girders where flange lateral bending is deemed significant, and for horizontally curved girders, the effects of the lateral bending must be considered in the design of the bolted splices for discretely braced top flanges of tub sections or discretely braced flanges of I-sections. The traditional elastic vector method may also be used in these cases to account for the effects of flange lateral bending on the design of the splice bolts. The shear on the flange bolt group is assumed caused by the flange force, calculated as described in the preceding paragraph. The flange force is calculated without consideration of the flange lateral bending. The moment on the bolt group is taken as the flange lateral bending moment due to the factored loads. At the strength limit state, the flange lateral bending moment due to the factored loads need not be multiplied by the factor, R_{cf} , from Eq. 6.13.6.1.4c-3 when computing the moment for the design of the splice. Splice plates subject to flange lateral bending should also be designed at the strength limit state for the combined effects of the appropriate flange force and the flange lateral bending moment due to the factored loads. Lateral flange bending can be ignored in the design of top flange splices once the flange is continuously braced.

6.13.6.1.5—Fillers

When bolts carrying loads pass through fillers 0.25 in. or more in thickness in axially loaded connections, including girder flange splices, either:

- The fillers shall be extended beyond the gusset or splice material, and the filler extension shall be secured by enough additional bolts to distribute the total stress in the member uniformly over the combined section of the member and the filler or
- As an alternative, the fillers need not be extended and developed provided that the factored resistance of the bolts in shear at the strength limit state, specified in Article 6.13.2.2, is reduced by the following factor:

$$R = \left[\frac{(1 + \gamma)}{(1 + 2\gamma)} \right] \quad (6.13.6.1.5-1)$$

where:

$$\gamma = A_f/A_p$$

C6.13.6.1.5

Fillers are to be secured by means of additional fasteners so that the fillers are, in effect, an integral part of a shear-connected component at the strength limit state. The integral connection results in well-defined shear planes and no reduction in the factored shear resistance of the bolts.

In lieu of extending and developing the fillers, the reduction factor given by Eq. 6.13.6.1.5-1 may instead be applied to the factored resistance of the bolts in shear. This factor compensates for the reduction in the nominal shear resistance of a bolt caused by bending in the bolt and will typically result in the need to provide additional bolts in the connection. The reduction factor is only to be applied on the side of the connection with the fillers. The factor in Eq. 6.13.6.1.5-1 was developed mathematically (Sheikh-Ibrahim, 2002), and verified by comparison to the results from an experimental program on axially loaded bolted splice connections with undeveloped fillers (Yura, et al., 1982). The factor is more general than a similar factor given in AISC (2005) in that it takes into account the areas of the main connected plate, splice plates and fillers and can be applied to fillers of any thickness. Unlike the empirical AISC factor, the factor given by Eq. 6.13.6.1.5-1

- A = sum of the area of the fillers on the top and bottom of the connected plate (in.²)
- A_p = smaller of either the connected plate area or the sum of the splice plate areas on the top and bottom of the connected plate (in.²)

For slip-critical connections, the factored slip resistance of a bolt, specified in Article 6.13.2.2, shall not be adjusted for the effect of the fillers.

Fillers 0.25 in. or more in thickness shall consist of not more than two plates, unless approved by the Engineer.

For bolted web splices with thickness differences of 0.0625 in. or less, no filler plates are required.

The specified minimum yield strength of fillers 0.25 in. or greater in thickness should not be less than the larger of 70 percent of the specified minimum yield strength of the connected plate and 36.0 ksi.

6.13.6.2—Welded Splices

Welded splice design and details shall conform to the requirements of the latest edition of *AASHTO/AWS D1.5M/D1.5 Bridge Welding Code* and the following provisions specified herein.

Welded splices shall be designed to resist the design moment, shear, or axial force specified in Article 6.13.1. Tension and compression members may be spliced by means of full penetration butt welds; splice plates should be avoided.

Welded field splices should be arranged to minimize overhead welding.

Material of different widths spliced by butt welds shall have symmetric transitions conforming to Figure 6.13.6.2-1. The type of transition selected shall be consistent with the detail categories of Table 6.6.1.2.3-1 for the groove-welded splice connection used in the design of the member. The contract documents shall specify that butt weld splices joining material of different thicknesses be ground to a uniform slope between the offset surfaces, including the weld, of not more than one in 2.5.

will typically be less than 1.0 for connections utilizing 0.25-in. thick fillers in order to ensure both adequate shear resistance and limited deformation of the connection.

For slip-critical connections, the factored slip resistance of a bolt need not be adjusted for the effect of the fillers. The resistance to slip between filler and either connected part is comparable to that which would exist between the connected parts if fillers were not present.

For fillers 0.25 in. or greater in thickness in axially loaded bolted connections, the specified minimum yield strength of the fillers should theoretically be greater than or equal to the specified minimum yield strength of the connected plate times the factor $[1/(1+\gamma)]$ in order to provide fully developed fillers that act integrally with the connected plate. However, such a requirement may not be practical or convenient due to material availability issues. As a result, premature yielding of the fillers, bolt bending and increased deformation of the connection may occur in some cases at the strength limit state. To control excessive deformation of the connection, a lower limit on the specified minimum yield strength of the filler plate material is recommended for fillers 0.25 in. or greater in thickness. Connections where the fillers are appropriately extended and developed or where additional bolts are provided according to Eq. 6.13.6.1.5-1 in lieu of extending the fillers, but that do not satisfy the recommended yield strength limit, will still have adequate reserve shear resistance in the connection bolts. However, such connections will have an increased probability of larger deformations at the strength limit state. For fillers less than 0.25 in. in thickness, the effects of yielding of the fillers and deformation of the connection are considered inconsequential. For applications involving the use of weathering steels, a weathering grade product should be specified for the filler plate material.

C6.13.6.2

Flange width transition details typically show the transition starting at the butt splice. Figure 6.13.6.2-1 shows a preferred detail where the splice is located a minimum of 3.0 in. from the transition for ease in fitting runoff tabs. Where possible, constant width flanges are preferred in a shipping piece.

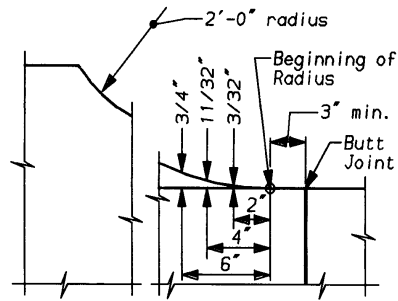

(a) Detail of Width Transition

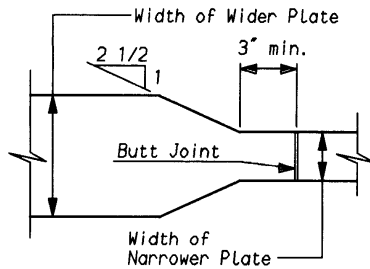

(b) Straight Tapered Transition

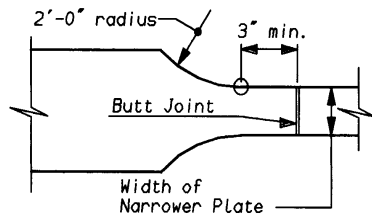

(c) 2'-0" Radius Transition

Figure 6.13.6.2-1—Splice Details

6.13.7—Rigid Frame Connections

6.13.7.1—General

All rigid frame connections shall be designed to resist the moments, shear, and axial forces due to the factored loading at the strength limit state.

C6.13.7.1

The provisions for rigid frame connections are well documented in Chapter 8 of ASCE (1971).

The rigidity is essential to the continuity assumed as the basis for design.

6.13.7.2—Webs

C6.13.7.2

The thickness of an unstiffened beam web shall satisfy:

$$t_w \geq \sqrt{3} \left(\frac{M_c}{\phi_v F_y d_b d_c} \right) \quad (6.13.7.2-1)$$

where:

F_y = specified minimum yield strength of the web (ksi)
 M_c = column moment due to the factored loadings (kip-in.)

- d_b = beam depth (in.)
 d_c = column depth (in.)
 ϕ_v = resistance factor for shear as specified in Article 6.5.4.2

When the thickness of the connection web is less than that given in Eq. 6.13.7.2-1, the web shall be strengthened by diagonal stiffeners or by a reinforcing plate in contact with the web over the connection area.

At knee joints where the flanges of one member are rigidly framed into the flange of another member, stiffeners shall be provided on the web of the second member opposite the compression flange of the first member where:

$$t_w < \frac{A_f}{t_b + 5k} \quad (6.13.7.2-2)$$

and opposite the tension flange of the first member where:

$$t_c < 0.4 \sqrt{A_f} \quad (6.13.7.2-3)$$

where:

- t_w = thickness of web to be stiffened (in.)
 k = distance from outer face of flange to toe of web fillet of member to be stiffened (in.)
 t_b = thickness of flange transmitting concentrated force (in.)
 t_c = thickness of flange of member to be stiffened (in.)
 A_f = area of flange transmitting concentrated load (in.²)

6.14—PROVISIONS FOR STRUCTURE TYPES

6.14.1—Through-Girder Spans

Where beams or girders comprise the main members of through-spans, such members shall be stiffened against lateral deformation by means of gusset plates or knee braces with solid webs connected to the stiffeners on the main members and the floorbeams. Design of gusset plates shall satisfy the requirements of Article 6.14.2.8.

6.14.2—Trusses

6.14.2.1—General

Trusses should have inclined end posts. Laterally unsupported hip joints shall be avoided.

Main trusses shall be spaced a sufficient distance apart, center-to-center, to prevent overturning.

Effective depths of the truss shall be assumed as follows:

- The distance between centers of gravity of bolted chords and

The provision for checking the beam or connection web ensures adequate strength and stiffness of the steel frame connection.

In bridge structures, diagonal stiffeners of minimum thickness will provide sufficient stiffness. Alternately, web thickness may be increased in the connection region.

The provisions for investigating a member subjected to concentrated forces applied to its flange by the flanges of another member framing into it are intended to prevent crippling of the web and distortions of the flange. It is conservative to provide stiffeners of a thickness equal to that of the flanges of the other member.

C6.14.1

This requirement may be combined with other plate stiffening requirements.

- The distance between centers of pins.

6.14.2.2—Truss Members

Members shall be symmetrical about the central plane of the truss.

If the shape of the truss permits, compression chords shall be continuous.

If web members are subject to reversal of stress, their end connections shall not be pinned.

Counters should be avoided.

6.14.2.3—Secondary Stresses

The design and details shall be such that secondary stresses will be as small as practicable. Stresses due to the dead load moment of the member shall be considered, as shall those caused by eccentricity of joints or working lines. Secondary stresses due to truss distortion or floorbeam deflection need not be considered in any member whose width measured parallel to the plane of distortion is less than one-tenth of its length.

6.14.2.4—Diaphragms

Diaphragms in trusses shall be provided according to the requirements specified in Article 6.7.4.4.

6.14.2.5—Camber

The length of the truss members shall be adjusted such that the camber will be equal to or greater than the deflection produced by the dead load.

The gross area of each truss member shall be used in computing deflections of trusses. If perforated plates are used, the effective area of the perforated plate shall be the net volume between centers of perforations divided by the length from center-to-center of perforations.

Design requirements for perforated plates shall satisfy the requirements specified in Articles 6.8.5.2 and 6.9.4.3.2.

6.14.2.6—Working Lines and Gravity Axes

Main members shall be proportioned so that their gravity axes will be as nearly as practicable in the center of the section.

In compression members of unsymmetrical section, such as chord sections formed of side segments and a cover

C6.14.2.2

Chord and web truss members should usually be made of H-shaped, channel shaped, or box-shaped members. The member or component thereof may be a rolled shape or a fabricated shape using welding or mechanical fasteners. Side plates or components should be solid. Cover plates or web plates may be solid or perforated.

In chords composed of angles in channel-shaped members, the vertical legs of the angles preferably should extend downward.

Counters are sometimes used as web members of light trusses.

Counters should be rigid. If used, adjustable counters should have open turnbuckles, and in the design of these members an allowance of 10.0 ksi shall be made for initial stress. Only one set of diagonals in any panel should be adjustable. Sleeve nuts and loop bars should not be used. The load factor for initial stress should be taken as 1.0.

plate, the gravity axis of the section shall coincide as nearly as practicable with the working line, except that eccentricity may be introduced to counteract dead load flexure. In two-angle bottom chord or diagonal members, the working line may be taken as the gage line nearest the back of the angle or at the center of gravity for welded trusses.

6.14.2.7—Portal and Sway Bracing

6.14.2.7.1—General

The need for vertical cross-frames used as sway bracing in trusses shall be investigated. Any consistent structural analysis with or without intermediate sway bracing shall be acceptable as long as equilibrium, compatibility, and stability are satisfied for all applicable limit states.

6.14.2.7.2—Through-Truss Spans

Through-truss spans shall have portal bracing or the strength and stiffness of the truss system shall be shown to be adequate without a braced portal. If portal bracing is used, it should be of the two-plane or box-type, rigidly connected to the end post and the top chord flanges, and be as deep as the clearance will allow. If a single-plane portal is used, it should be located in the central transverse plane of the end posts, with diaphragms between the webs of the posts to provide for a distribution of the portal stresses.

The portal, with or without bracing, shall be designed to take the full reaction of the top chord lateral system, and the end posts shall be designed to transfer this reaction to the truss bearings.

6.14.2.7.3—Deck Truss Spans

Deck truss spans shall have sway bracing in the plane of the end posts, or the strength and stiffeners of the truss system shall be shown to be adequate. Where sway bracing is used, it shall extend the full depth of the trusses below the floor system, and the end sway bracing shall be proportioned to carry the entire upper lateral load to the supports through the end posts of the truss.

6.14.2.8—Gusset Plates

The provisions of Articles 6.13.4 and 6.13.5 shall apply, as applicable.

Gusset or connection plates should be used for connecting main members, except where the members are pin-connected. The fasteners connecting each member shall be symmetrical with the axis of the member, so far as practicable, and the full development of the elements of the member should be given consideration.

Re-entrant cuts, except curves made for appearance, should be avoided as far as practicable.

C6.14.2.7.3

Generally, full depth sway bracing is easily accommodated in deck trusses, and its use is encouraged.

C6.14.2.8

Following the 2007 collapse of the I-35W bridge in Minneapolis, the traditional procedures for designing gusset plates, including the provisions of this Article, have been under extensive review. As of Spring 2008, new design procedures have not been codified. Guidance from FHWA is expected shortly. Designers are advised to obtain the latest approved recommendations from Owners.

The maximum stress from combined factored flexural and axial loads shall not exceed $\phi_t F_y$ based on the gross area.

The maximum shear stress on a section due to the factored loads shall be $\phi_v F_y / \sqrt{3}$ for uniform shear and $\phi_v 0.74 F_y / \sqrt{3}$ for flexural shear computed as the factored shear force divided by the shear area.

If the length of the unsupported edge of a gusset plate exceeds $2.06(E/F_y)^{1/2}$ times its thickness, the edge shall be stiffened. Stiffened and unstiffened gusset edges shall be investigated as idealized column sections.

6.14.2.9—Half Through-Trusses

The vertical truss members and the floorbeams and their connections in half through-truss spans shall be proportioned to resist a lateral force of not less than 0.30 klf applied at the top chord panel points of each truss, considered as a permanent load for the Strength I Load Combination and factored accordingly.

The top chord shall be considered as a column with elastic lateral supports at the panel points.

6.14.2.10—Factored Resistance

The factored resistance of tension members shall satisfy the requirements specified in Article 6.8.2.

The factored resistance of compression members shall satisfy the requirements specified in Article 6.9.2.

The nominal bending resistance of the members whose factored resistance is governed by interaction equations, specified in Articles 6.8.2.3 or 6.9.2.2, shall be evaluated as specified in Article 6.12.

6.14.3—Orthotropic Deck Superstructures

6.14.3.1—General

The provisions of this Article shall apply to the design of steel bridges that utilize a stiffened steel plate as a deck.

An orthotropic deck shall be considered an integral part of the bridge superstructure and shall participate in resisting global force effects on the bridge. Connections between the deck and the main structural members shall be designed for interaction effects specified in Article 9.4.1.

The combined effects of global and local forces shall be considered when analyzing the orthotropic deck. The effect of torsional distortions of the cross-sectional shape shall be accounted for in analyzing the deck plate and girders of orthotropic box girder bridges.

6.14.3.2—Decks in Global Compression

6.14.3.2.1—General

The following potential stability-related behaviors shall be evaluated in the orthotropic plate: local buckling of the deck plate between ribs, local buckling of the rib

C6.14.2.9

A discussion of the buckling analysis of columns with elastic lateral supports is contained in Timoshenko and Gere (1961) and in Galambos (1998).

C6.14.3.1

Orthotropic deck roadways may be used as upper or lower flanges of trusses, plate girder or box girder bridges, stiffening members of suspension or cable-stayed bridges, tension ties of arch bridges, etc.

Detailed provisions for the design of orthotropic decks are given in Article 9.8.3.

wall, and buckling of the orthotropic panel between floorbeams.

6.14.3.2.2—Local Buckling

For local buckling, the slenderness of each component shall be considered: the rib spacing to deck thickness ratio, the closure spacing to deck thickness ratio (for closed ribs), and the rib height to rib thickness ratio for the ribs. The effective width for each component shall be determined in accordance with Article 6.9.4.2.

C6.14.3.2.2

Article 6.9.4 applies the recommended method for quantification of strength reduction resulting from local buckling, as given by *Specification for Structural Steel Buildings* for slender stiffened elements (AISC, 2005). This method is based on tests results from Winter (1947) and is also the basis of *North American Specification for the Design of Cold-Formed Steel Structural Members* (AISI, 2001).

For local buckling considerations, the deck plate and the rib walls can be considered stiffened elements because both longitudinal edges have support.

6.14.3.2.3—Panel Buckling

Each panel between floorbeams may be simplified for analysis as an isolated strut comprised of the rib and effective deck width specified in Figure 6.14.3.2.3-1.

C6.14.3.2.3

In-plane compressive resistance is controlled by stability. Buckling behavior of stiffened plate panels is a complicated problem due to the two-way orthogonal stiffening behavior and partially restrained boundary supports on four sides of the panel. A summary of relevant historical research on this subject is provided in Troitsky (1977) and SSRC (1998). Similar to stiffened plate elements, reserve post-buckling strength in the panel exists beyond the point of initial buckling and can be quantified by use of the local effective width approach.

A simplified approach to estimating the buckling strength of the stiffened panel is to analyze the panel as a series of isolated column struts comprised of a stiffener and the associated effective width of plating (Horne and Narayanan, 1977). Then, basic column theory can be employed. This approach conservatively neglects the bending and membrane stiffness of the panel in the transverse direction and the torsional stiffness of the closed rib sections. Alternately, refined analysis may be used for a more accurate assessment of panel buckling strength with full consideration of the orthogonal stiffening behavior.

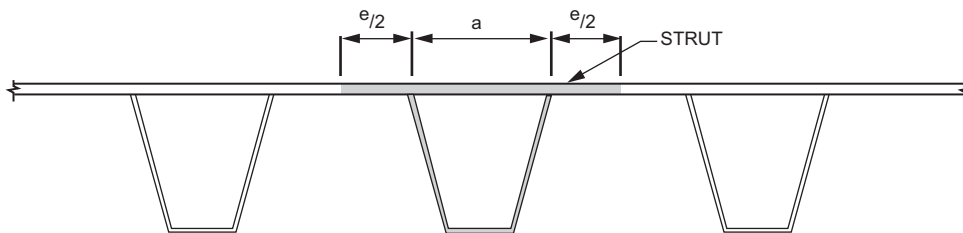

Figure 6.14.3.2.3-1—Idealized Strut for Evaluation of Compressive Resistance

where:

a = the width of the closed rib at the deck plate, centerline rib plate to centerline rib plate (in.)

e = the clear spacing between adjacent ribs, centerline rib plate to centerline rib plate (in.)

The critical buckling stress of the strut shall be determined in accordance with Article 6.9.4 or by methods of refined analysis as defined in Article 4.6.3.2.3.

6.14.3.3—Effective Width of Deck

The provisions of Article 4.6.2.6.4 shall apply.

6.14.3.4—Superposition of Global and Local Effects

In calculating extreme force effects in the deck, global and local effects shall be superimposed. Such combined force effects shall be computed for the same configuration and position of live load.

6.14.4—Solid Web Arches

6.14.4.1—Moment Amplification for Deflection

For moment amplification, provisions specified in Article 4.5.3.2.2c shall be satisfied.

6.14.4.2—Web Slenderness

The slenderness of the webs of arch ribs shall satisfy:

$$\frac{D}{t_w} \leq k \sqrt{\frac{E}{f_a}} \quad (6.14.4.2-1)$$

where:

f_a = axial stress due to the factored loads (ksi)
 k = plate stability factor specified in Table 6.14.4.2-1

Table 6.14.4.2-1—Plate Slenderness of Arches

Condition	k	I_s
No longitudinal stiffener	1.25	—
One longitudinal stiffener	1.88	$I_s = 0.75 D t_w^3$
Two longitudinal stiffeners	2.51	$I_s = 2.2 D t_w^3$

The moment of inertia of the stiffeners about an axis parallel to the web at the base of the stiffener shall not be less than that specified in Table 6.14.4.2-1.

The width to thickness ratio for the stiffeners shall satisfy:

$$\frac{b}{t_s} \leq 0.408 \sqrt{\frac{E}{f_a + \frac{f_b}{3}}} \leq 12 \quad (6.14.4.2-2)$$

where:

f_b = maximum stress due to the factored loads, including moment amplification (ksi)

6.14.4.3—Flange Stability

The width-to-thickness ratio of flanges shall satisfy:

- For the width between webs:

$$\frac{b}{t} \leq 1.06 \sqrt{\frac{E}{f_a + f_b}} \quad (6.14.4.3-1)$$

- For overhang widths:

$$\frac{b}{t} \leq 0.408 \sqrt{\frac{E}{f_a + f_b}} \leq 12 \quad (6.14.4.3-2)$$

6.15—PILES

6.15.1—General

Piles shall be designed as structural members capable of safely supporting all imposed loads.

For a pile group composed of only vertical piles which is subjected to lateral load, the pile structural analysis shall include explicit consideration of soil-structure interaction effects as specified in Article 10.7.3.9.

6.15.2—Structural Resistance

Resistance factors, ϕ_c and ϕ_f , for the strength limit state shall be taken as specified in Article 6.5.4.2. The resistance factors for axial resistance of piles in compression which are subject to damage due to driving shall be applied only to that section of the pile likely to experience damage. Therefore, the specified ϕ_c factors for axial resistance of 0.50 to 0.70 for piles in compression without bending shall be applied only to the axial capacity of the pile. The ϕ_c factors of 0.70 and 0.80 and the ϕ_f factor of 1.00 shall be applied to the combined axial and flexural resistance of the pile in the interaction equation for the compression and flexure terms, respectively.

C6.15.1

Typically, due to the lack of a detailed soil-structure interaction analysis of pile groups containing both vertical and battered piles, evaluation of combined axial and flexural loading will only be applied to pile groups containing all vertical piles.

C6.15.2

Due to the nature of pile driving, additional factors must be considered in selection of resistance factors that are not normally accounted for in steel members. The factors considered in development of the specified resistance factors include:

- Unintended eccentricity of applied load about pile axis,
- Variations in material properties of pile, and
- Pile damage due to driving.

These factors are discussed by Davisson (1983). While the resistance factors specified herein generally conform to the recommendations given by Davisson (1983), they have been modified to reflect current design philosophy.

The factored compressive resistance, P_r , includes reduction factors for unintended load eccentricity and material property variations, as well as a reduction for

potential damage to piles due to driving, which is most likely to occur near the tip of the pile. The resistance factors for computation of the factored axial pile capacity near the tip of the pile are 0.50 to 0.60 and 0.60 to 0.70 for severe and good driving conditions, respectively. These factors include a base axial compression resistance factor ϕ_c equal to 0.90, modified by reduction multipliers of 0.78 and 0.87 for eccentric loading of H-piles and pipe piles, respectively, and reduction multipliers of 0.75 and 0.875 for difficult and moderately difficult driving conditions.

For steel piles, flexure occurs primarily toward the head of the pile. This upper zone of the pile is less likely to experience damage due to driving. Therefore, relative to combined axial compression and flexure, the resistance factor for axial resistance range of $\phi_c = 0.70$ to 0.80 accounts for both unintended load eccentricity and pile material property variations, whereas the resistance factor for flexural resistance of $\phi_f = 1.00$ accounts only for base flexural resistance. This design approach is illustrated on Figure C6.15.2-1 which illustrates the depth to fixity as determined by P - Δ analysis.

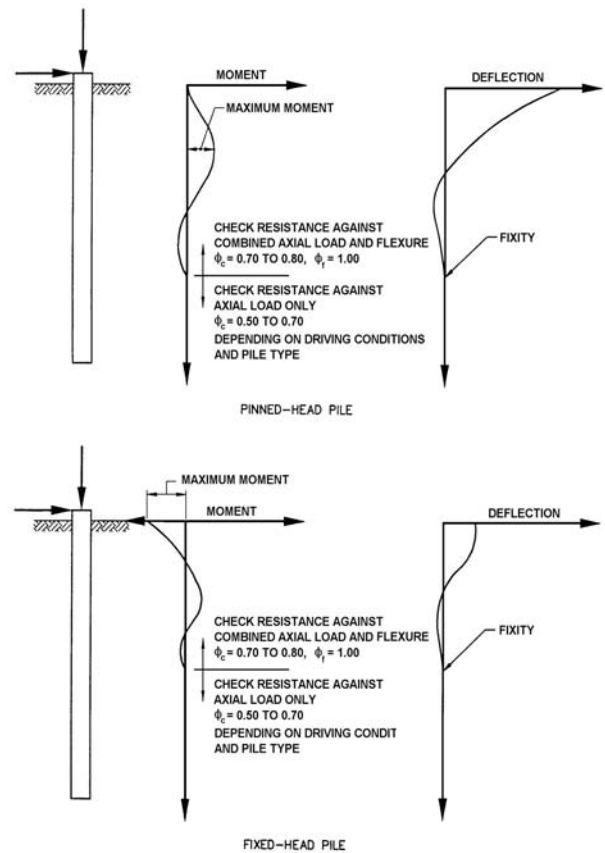

Figure C6.15.2-1—Distribution of Moment and Deflection in Vertical Piles Subjected to Lateral Load

If an unusual situation resulted in significant bending at the pile tip, possible pile damage should be considered in evaluating resistance to combined flexure and axial load.

6.15.3—Compressive Resistance

6.15.3.1—Axial Compression

For piles under axial load, the factored resistance of piles in compression, P_r , shall be taken as specified in Article 6.9.2.1 using the resistance factor, ϕ_c , specified in Article 6.5.4.2.

6.15.3.2—Combined Axial Compression and Flexure

Piles subjected to axial load and flexure shall be designed in accordance with Article 6.9.2.2 using the resistance factors, ϕ_c and ϕ_f , specified in Article 6.5.4.2.

6.15.3.3—Buckling

Instability of piles which extend through water or air shall be accounted for as specified in Article 6.9. Piles which extend through water or air shall be assumed to be fixed at some depth below the ground. Stability shall be determined in accordance with provisions in Article 6.9 for compression members using an equivalent length of the pile equal to the laterally unsupported length, plus an embedded depth to fixity. The depth to fixity shall be determined in accordance with Article 10.7.3.13.4 for battered piles or P - Δ analysis for vertical piles.

6.15.4—Maximum Permissible Driving Stresses

Maximum permissible driving stresses for top driven steel piles shall be taken as specified in Article 10.7.8.

6.16—PROVISIONS FOR SEISMIC DESIGN

6.16.1—General

The provisions of Article 6.16 shall apply only to the design of slab-on-steel-girder bridge superstructures at the extreme event limit state.

In addition to the requirements specified herein, minimum support length requirements specified in Article 4.7.4.4 shall also apply.

A clear seismic load path shall be established within the superstructure to transmit the inertia forces to the substructure based on the stiffness characteristics of the concrete deck, cross-frames or diaphragms, and bearings. The flow of the seismic forces shall be accommodated through all affected components and connections of the steel superstructure within the prescribed load path, including, but not limited to, the longitudinal girders, cross-frames or diaphragms, steel-to-steel connections, deck-to-steel interface, bearings, and anchor bolts.

C6.15.3.3

An approximate method acceptable to the Engineer may be used in lieu of a P - Δ analysis.

C6.16.1

These Specifications are based on the recent work published by Itani et al. (2010), NCHRP (2002, 2006), MCEER/ATC (2003), Caltrans (2006), AASHTO's *Guide Specifications for LRFD Seismic Bridge Design* (2009), and AISC (2005 and 2005b). The Loma Prieta earthquake of 1989, Petrolia earthquakes of 1992, Northridge earthquake of 1994, and the Hyogoken-Nanbu (Kobe) earthquake of 1995 provided new insights into the behavior of steel details under seismic loads. The Federal Highway Administration, Caltrans, and the American Iron and Steel Institute initiated a number of research projects that have produced information that is useful for both the design of new steel-girder structures and the retrofitting of existing steel-girder structures.

This new information relates to all facets of seismic engineering, including design spectra, analytical techniques, and design details. Bridge designers working

in Seismic Zones 2, 3, or 4 are encouraged to avail themselves of current research reports and other literature to augment these Specifications.

Steel-girder bridges are generally considered to perform well in earthquakes. However, the aforementioned earthquakes showed the vulnerability of steel-girder bridges to damage if they are not designed and detailed to resist the seismic motions (Roberts, 1992; Astaneh-Asl et al., 1994; Itani and Reno, 1995; Bruneau et al., 1996; and Carden et al., 2005a). Typical damage included unseated longitudinal girders and failure of cross-frames and their connections, expansion joints, and bearings. In a few cases, most notably during the Kobe earthquake, major gravity load-carrying members failed, triggered in some instances by the failure of components elsewhere in the superstructure. These earthquakes confirmed the vulnerability of steel-girder bridges during seismic events. New areas of concern that emerged included:

- Lack of understanding of the seismic load paths in steel-girder bridges,
- Damage to steel superstructure components, e.g. girders, shear connectors, end cross-frames, bearing stiffeners, bearings, and anchor bolts, and
- Failure of steel substructures.

Seismic design specifications in the U.S. currently do not require the explicit design of bridge superstructures for seismic loads. The assumption is made that a superstructure that is designed for out-of-plane gravity load has sufficient strength, by default, to resist in-plane seismic loads. However, recent earthquakes have shown the fallacy of this assumption and shown that a load path should be clearly defined, analyzed, and designed for seismic loads.

Research on the seismic behavior of steel-girder bridge superstructures (Astaneh-Asl and Donikian, 1995; Itani, 1995; Dicleli and Bruneau, 1995a and 1995b; Itani and Rimal, 1996; Carden et al., 2005a and 2005b, and Bahrami et al., 2010) further confirmed that seismically induced damage is likely in superstructures subjected to large earthquakes and that appropriate measures should be taken to ensure satisfactory seismic performance.

The Kobe earthquake has demonstrated the potential vulnerability of non-ductile steel substructures. However, given that steel substructures are less commonly used in North America and are not of a standardized type when used, they are not addressed herein. The designer may find information on this topic in AASHTO's *Guide Specifications for LRFD Seismic Bridge Design* (2009) and MCEER/ATC (2003) to complement information available elsewhere in the literature.

These specifications concentrate on the seismic design and detailing of steel-girder bridge superstructures. These types of superstructures have experienced moderate earthquakes and have been investigated analytically and experimentally in the aforementioned research. The

6.16.2—Materials

Structural steels used within the seismic load path shall meet the requirements of Article 6.4.1, except as modified herein.

When a member or connection is protected by capacity design, the required nominal resistance of the member or connection shall be determined based on the expected yield strength, $R_y F_y$, of the adjoining member(s), where F_y is the specified minimum yield strength of the steel used in the adjoining member(s) and R_y is the ratio of the expected yield strength to the specified minimum yield strength. For AASHTO M 270M/M 270 (ASTM A709/A709M) Grade 36, R_y shall be taken equal to 1.5 for hot-rolled structural shapes and 1.3 for plates. For AASHTO M 270M/M 270 (ASTM A709/A709M) Grades 50, 50S and 50W, R_y shall be taken equal to 1.1.

6.16.3—Design Requirements for Seismic Zone 1

For steel-girder bridges located in Seismic Zone 1, defined as specified in Article 3.10.6, the design of all support cross-frame or diaphragm members and their connections and the connections of the superstructure to the substructure shall satisfy the minimum requirements specified in Articles 3.10.9 and 4.7.4.4.

6.16.4—Design Requirements for Seismic Zones 2, 3, or 4

6.16.4.1—General

Components of slab-on-steel girder bridges located in Seismic Zones 3 or 4, defined as specified in Article 3.10.6, shall be designed using one of the two types of response strategies specified in this Article. One of the two types of response strategies should be considered for bridges located in Seismic Zone 2:

common thread among these investigations was that these types of superstructures are vulnerable during earthquakes if they are not designed and detailed to resist the resulting seismic forces. A continuous and clearly defined load path is necessary for the transmission of the superstructure inertia forces to the substructure.

C6.16.2

Previous earthquakes have shown that cross-frames at support locations transfer the inertia forces of the superstructure to the substructure. Therefore, the connections of the adjoining cross-frame members must be protected during seismic events. This is achieved by utilizing a capacity-design methodology in which the cross-frame connections are designed based on the expected nominal resistance of the adjoining members. This methodology serves to confine the ductility demand to the members that have the available excess resistance to ensure ductile behavior. In the capacity-design methodology, all the components surrounding the nonlinear element are designed based on the maximum expected nominal resistance of that element. The capacity-design methodology requires a realistic estimate of the expected nominal resistance of the designated yielded members. To this end, the expected yield strength of various steel materials has been established through a survey of mill test reports and ratios of the expected to nominal yield strength, R_y , have been provided elsewhere (AISC, 2005b) and they are adopted herein. The expected resistance of the designated member is therefore to be determined based on the expected yield strength, $R_y F_y$, which amplifies the nominal resistance to account for the effect of strain-hardening if the member is expected to undergo nonlinear response.

C6.16.3

These requirements for Zone 1 are to ensure a clear load path for seismic forces.

C6.16.4.1

An alternative seismic performance criterion for slab-on-steel-girder bridges is to provide an elastic superstructure in combination with a ductile substructure. In such cases, the support cross-frames are designed to transfer the seismic forces elastically and the inelasticity is limited to the concrete substructure, which is typically

- *Type 1*—Design an elastic superstructure with a ductile substructure according to the provisions of Article 6.16.4.4.
- *Type 2*—Design an elastic superstructure and substructure with a fusing mechanism at the interface between the superstructure and substructure according to the provisions of Article 6.16.4.4.

The deck and shear connectors on bridges located in Seismic Zones 3 or 4 shall also satisfy the provisions of Articles 6.16.4.2 and 6.16.4.3, respectively. If Strategy Types 1 or 2 are invoked for bridges in Seismic Zone 2, the provisions of Articles 6.16.4.2 and 6.16.4.3 should be considered.

Support cross-frame members on bridges located in Seismic Zones 3 or 4 shall be considered primary members for seismic design.

Structural analysis for seismic loads shall consider the relative stiffness of the concrete deck, girders, support cross-frames or diaphragms, and the substructure.

6.16.4.2—Deck

Reinforced concrete decks attached by shear connectors satisfying the requirements of Article 6.16.4.3 shall be designed to provide horizontal diaphragm action to transfer seismic forces to the supports as specified in this Article.

Where the deck has a span-to-width ratio of 3.0 or less and the net mid-span lateral seismic displacement of the superstructure is less than twice the average of the adjacent lateral seismic support displacements, the deck within that span may be assumed to act as a rigid horizontal diaphragm designed to resist only the shear resulting from the seismic forces. Otherwise, the deck shall be assumed to act as a flexible horizontal diaphragm designed to resist shear and bending, as applicable, resulting from the seismic forces.

The transverse seismic shear force on the deck, F_{px} , within the span under consideration shall be determined as:

$$F_{px} = \frac{W_{px}}{W} F \quad (6.16.4.2-1)$$

where:

designed according to the provisions of Article 5.10.11. As used in this Article, an elastic component is one in which the demand-to-nominal resistance ratio is less than 1.0.

Providing an essentially elastic superstructure and substructure by utilizing response modification devices such as base isolation as a fusing mechanism is a viable alternative strategy for designing steel-girder bridges in Seismic Zones 3 and 4.

The provision of an alternative fusing mechanism between the interface of the superstructure and substructure by shearing off the anchor bolts is also an adequate seismic strategy. However, care must be taken to provide adequate seat width and to stiffen the girder web at support locations. It is anticipated that large deformations will occur in the superstructure at support locations during a seismic event where this strategy is employed.

The recommended design provisions for bridges located in Seismic Zone 2 have been included in this Article with the requirements for bridges located in Seismic Zones 3 and 4. Bridges located in Seismic Zone 2 have a reasonable probability of being subjected to significant seismic forces because the upper boundary for this zone in the current edition of the specifications is significantly higher than in previous editions due to the increase in the return period for the design earthquake from 500 to 1000 yr.

In horizontally curved or skewed steel bridges, or both, cross-frame forces due to gravity loads may govern over seismic loads depending on boundary conditions at abutments; pier flexibility; and degree of curvature or skew, or both.

C6.16.4.2

In general, reinforced concrete decks on steel-girder bridges with adequate stud connectors have sufficient rigidity in their horizontal plane that their response approaches rigid-body motion. Therefore, the deck can provide a horizontal diaphragm action to transfer seismic forces to support cross-frames or diaphragms. The seismic forces are collected at the support cross-frames or diaphragms and transferred to the substructure through the bearings and anchor bolts. Thus, the support cross-frames or diaphragms must be designed for the resulting seismic forces. The lateral loading of the intermediate cross-frames in between the support locations for straight bridges is minimal in this case, consisting primarily of the local tributary inertia forces from the girders. Adequate stud connectors are required to ensure the necessary diaphragm action as previous earthquake reconnaissance showed that for some bridges in California in which the shear connectors at support locations were damaged during a seismic event, the deck in fact slid on the top of the steel girders (Roberts, 1992 and Carden et al., 2005a).

During a seismic event, inertia forces generated by the mass of the deck must be transferred to the support cross-frames or diaphragms. The seismic forces are transferred

F = force (kip) determined as follows:

- For structures in Seismic Zone 2 designed using Strategy Type 1, the elastic transverse base shears at the support under consideration divided by the response modification factor, R , specified in Table 3.10.7.1-1.
- For structures in Seismic Zones 3 or 4 designed using Strategy Type 1, the lesser of:
 - The elastic transverse base shears at the support under consideration divided by the response modification factor, R , specified in Table 3.10.7.1-1, and
 - The inelastic hinging force determined as specified in Article 3.10.9.4.3 multiplied by 1.2 or 1.4 for ASTM A706 or ASTM A615 Grade 60 reinforcement, respectively.
- For structures in Seismic Zones 2, 3, or 4 designed using Strategy Type 2, the expected lateral resistance of the fusing mechanism multiplied by the applicable overstrength factor.

W = total weight of the deck, steel girders, and, where applicable, cap beam, plus one-half the column weight within the span under consideration (kip)

W_{px} = weight of the deck plus one-half of the weight of the steel girders in the span under consideration (kip)

through longitudinal and transverse shear forces and axial forces.

In cases where the deck may be idealized as a rigid horizontal diaphragm, F_{px} is distributed to the supports based on their relative stiffnesses. In cases where the deck must be idealized as a flexible horizontal diaphragm, F_{px} is distributed to the supports based on their respective tributary areas. Decks idealized as rigid diaphragms need only be designed for shear. Decks idealized as flexible diaphragms must be designed for both shear and bending as maximum in-plane deflections of the deck under lateral loads in this case are more than twice the average of the lateral deflections at adjacent support locations. Concrete decks may be designed for shear and bending moments based on strut and tie models (STM), as defined in Article 5.6.3.

In cases where the deck cannot provide horizontal diaphragm action, the Engineer should consider providing lateral bracing to serve as a horizontal diaphragm to transfer the seismic forces.

F_{px} in Eq. 6.16.4.2-1 represents the total transverse seismic shear force that the deck is subjected to within a particular span. At skewed supports in structures designed using Strategy Type 1, F should be taken as the sum of the absolute values of the components of the transverse and longitudinal base shears parallel to the skew combined as specified in Article 3.10.8, as shown in Figure C6.16.4.2-1.

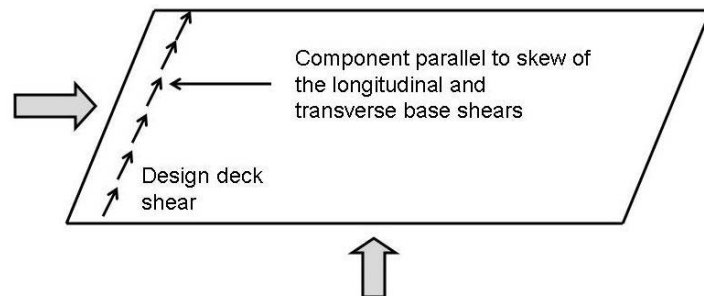

Figure C6.16.4.2-1—Design Deck Shear, F_{px} , at Skewed Supports

Shear keys are typically designed to fuse during the design event earthquake. In lieu of experimental test data, the overstrength ratio for shear key resistance may be obtained from *Guide Specifications for LRFD Seismic Bridge Design* (2009). Thus, where reinforced concrete shear keys are used as a fusing mechanism, the expected lateral resistance of the shear keys, including an overstrength factor, should be taken equal to $1.5V_{ni}$, where V_{ni} is equal to the nominal interface shear resistance determined as specified in Article 5.8.4.

6.16.4.3—Shear Connectors

Stud shear connectors shall be provided along the interface between the deck and the steel girders, or along the interface between the deck and the top of the support

C6.16.4.3

Stud shear connectors play a significant role in transferring the seismic forces from the deck to the support cross-frames or diaphragms. These seismic forces are

cross-frames or diaphragms, or both, as necessary to transfer the seismic forces. If reinforced concrete diaphragms that are connected integrally with the bridge deck are used at support locations, then the shear connectors on the steel girders at those locations need not be designed according to the provisions of this Article.

The shear connectors on the girders assumed effective at the support under consideration shall be taken as those spaced no further than $9t_w$ on each side of the outer projecting element of the bearing stiffeners at that support.

The diameter of the shear connectors within this region shall not be greater than 2.5 times the thickness of the top chord of the cross-frame or the top flange of the diaphragm.

At support locations, shear connectors on the girders or on the support cross-frames or diaphragms, or both, as necessary, shall be designed to resist the combination of shear and axial forces corresponding to the transverse seismic shear force, F_{px} , determined as specified in Article 6.16.4.2.

The resistance of stud shear connectors subject to combined shear and axial forces shall be evaluated according to the tension-shear interaction equation given as follows:

$$\left(\frac{N_u}{N_r}\right)^{5/3} + \left(\frac{Q_u}{Q_r}\right)^{5/3} \leq 1.0 \quad (6.16.4.3-1)$$

in which:

$$h_h = h_{eff} - d_h \geq \frac{w_h}{3} \quad (6.16.4.3-2)$$

$$\begin{aligned} N_r &= \text{factored tensile resistance of a single stud shear connector (kip)} \\ &= \phi_{st} N_n \end{aligned} \quad (6.16.4.3-3)$$

$$\begin{aligned} N_n &= \text{nominal tensile resistance of a single stud shear connector (kip)} \\ &= \psi_g \psi_{ed} \frac{A_{nc}}{A_{nco}} N_b \leq A_{sc} F_u \end{aligned} \quad (6.16.4.3-4)$$

ψ_g = group effect modification factor taken as follows:

- For transverse spacing:
 - $\psi_g = 0.95$ for two studs
 - $\psi_g = 0.90$ for three studs
- For longitudinal spacing:
 - $\psi_g = 0.95$ for spacing $\leq 3h_{eff}$
 - $\psi_g = 1.0$ for spacing $> 3h_{eff}$

transferred to the substructure at support locations. Thus, the shear connectors at support locations are subjected to the largest seismic forces, unless reinforced concrete diaphragms that are connected integrally with the bridge deck are used. Failure of these shear connectors will cause the deck to slip on the top flange of the girder and, thus, alter the seismic load path (Caltrans, 2001; Carden et al., 2005a; and Bahrami et al., 2010).

The shear center of composite steel-girder superstructures is located above the deck (Zahrai and Bruneau, 1998 and Bahrami et al., 2010). Therefore, during a seismic event, the superstructure will be subjected to torsional moments along the longitudinal axis of the bridge that produce axial forces on the shear connectors in addition to the longitudinal and transverse shears. Lateral deformations during a seismic event produce double curvature in the top chord of the cross-frame, creating axial forces in the shear connectors on that member that must be considered. Experimental and analytical investigations (Carden et al., 2004 and Bahrami et al., 2010) showed that the seismic demand on shear connectors that are placed only on the girders at support locations may cause significant damage to the connectors and the deck.

Appendix D of ACI (2008) provides equations for anchorage to concrete of pre- and post-installed anchors subject to shear and axial forces. However, these equations are not used in this Article for the design of shear connectors on slab-on-steel-girder bridges subject to combined shear and axial forces. Mouras et al. (2008) investigated the behavior of shear connectors placed on a steel girder under static and dynamic axial loads. The effects of haunches in reinforced concrete decks, stud length, the number of studs, and the arrangement of the studs in the transverse and longitudinal directions of the bridge were investigated. Based on this investigation, several modifications were recommended to the ACI Appendix D equations that are reflected in the equations given in this Article. These modifications ensure a ductile response of the shear connectors that is beneficial in seismic applications. The modifications are as follows:

- Provision for adequate embedment of the shear connectors to engage the reinforcement in the deck slab,
- Use of an effective haunch height instead of the effective height given in the ACI Appendix D equations, and
- Consideration of a group modification factor for longitudinal and transverse spacing. This factor accounts for the overlapping of the cones when studs are closely spaced.

The calculation of the projected area of concrete failure for a single stud shear connector based in the concrete breakout resistance in tension, A_{nco} , is illustrated in Figure C6.16.4.3-1.

$$\Psi_{ed} = 0.7 + 0.3 \frac{C_a}{1.5h_h} \leq 1.0 \quad (6.16.4.3-5)$$

A_{nco} = projected area of concrete failure for a single stud shear connector based on the concrete breakout resistance in tension (in.²)

$$= 9h_h^2 \quad (6.16.4.3-6)$$

N_b = concrete breakout resistance in tension of a single stud shear connector in cracked concrete (kip)

$$= 0.76\sqrt{f'_c}h_h^{1.5} \quad (6.16.4.3-7)$$

where:

ϕ_{st} = resistance factor for shear connectors in tension specified in Article 6.5.4.2

A_{nc} = projected area of concrete for a single stud shear connector or group of connectors approximated from the base of a rectilinear geometric figure that results from projecting the failure surface outward $1.5h_h$ from the centerline of the single connector or, in the case of a group of connectors, from a line through a row of adjacent connectors (in.²)

A_{sc} = cross-sectional area of a stud shear connector (in.²)

C_a = smallest edge distance from center of stud to the edge of the concrete (in.)

d_h = depth of haunch (in.)

F_u = specified minimum tensile strength of a stud shear connector determined as specified in Article 6.4.4 (ksi)

h_{eff} = effective embedment depth of a stud shear connector (in.)

h_h = effective height of the stud above the top of the haunch to the underside of the head (in.)

N_u = seismic axial force demand per stud at the support cross-frame or diaphragm location under consideration (kip)

Q_u = seismic shear demand per stud at the support cross-frame or diaphragm location under consideration due to the governing orthogonal combination of seismic shears (kip)

Q_r = factored shear resistance of a single stud shear connector determined as specified in Article 6.10.10.4.1 (kip)

w_h = width of haunch perpendicular to bridge span axis (in.)

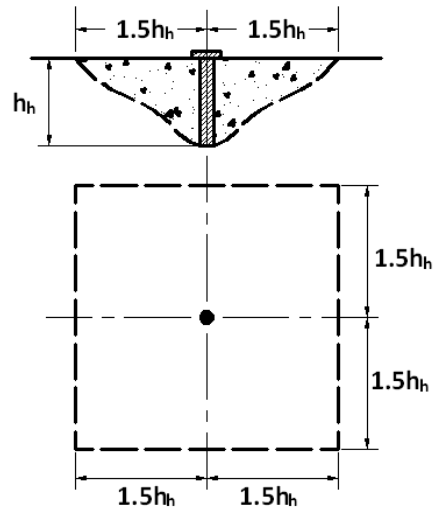

$$A_{nco} = (1.5h_h + 1.5h_h)(1.5h_h + 1.5h_h) = 9h_h^2 \quad (C6.16.4.3-1)$$

Figure C6.16.4.3-1—Calculation of A_{nco}

The calculation of A_{nc} for a group of four studs consisting of two rows with two studs per row is illustrated in Figure C6.16.4.3-2.

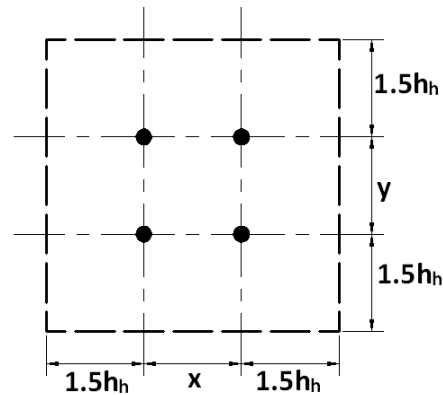

$$A_{nc} = (3h_h + x)(3h_h + y) \quad (C6.16.4.3-2)$$

Figure C6.16.4.3-2—Calculation of A_{nc} for a Group of Four Studs (two rows with two studs per row)

Experimental investigation by Bahrami et al. (2010) showed that these equations for the shear and axial resistance and their interaction may be used to satisfactorily determine the resistance of stud shear connectors under the combined loading effects.

For the seismic design of continuous composite spans, shear connectors should be provided throughout the length of the bridge. The requirements of this Article notwithstanding, should shear connectors be omitted in regions of negative flexure, positive attachment of the deck to the support cross-frames or diaphragms located at interior piers must still be provided. Analytical investigation (Carden et al., 2004) showed that a lack of

shear connectors in regions of negative flexure caused the seismic forces to be transferred into the steel girders at points of permanent load contraflexure, causing large weak-axis bending stresses in the girders. In addition, the intermediate cross-frames were subjected to large seismic forces, while the support cross-frames were subjected to smaller forces. This indicated that the seismic load path had been significantly altered.

6.16.4.4—Elastic Superstructures

For an elastic superstructure, support cross-frame members or support diaphragms shall be designed according to the applicable provisions of Articles 6.7, 6.8, or 6.9, or some combination thereof, to remain elastic during a seismic event.

The lateral force, F , for the design of the support cross-frame members or support diaphragms shall be determined as specified in Article 6.16.4.2 for structures designed using Strategy Types 1 or 2, as applicable.

C6.16.4.4

To achieve an elastic superstructure, the various components of the support cross-frames or the support diaphragms, as applicable, must be designed to remain elastic under the forces that are generated during the design earthquake according to the applicable provisions of Articles 6.7, 6.8, or 6.9, or some combination thereof. No other special seismic requirements are specified for these members in this case.

The elastic superstructure can have steel cross-frames of various configurations, steel diaphragms, or reinforced concrete diaphragms. The Tennessee DOT has as an alternative used reinforced concrete diaphragms over bent locations. The details of these diaphragms and others are discussed in Bahrami et al. (2010) and Itani and Reno (1995).

6.17—REFERENCES

- AASHTO. 1991. *Guide Specifications for Alternate Load Factor Design Procedures for Steel Beam Bridges Using Braced Compact Sections*. American Association of State Highway and Transportation Officials, Washington, DC.
- AASHTO. 1993. *Guide Specifications for Horizontally Curved Highway Bridges*. American Association of State Highway and Transportation Officials, Washington, DC.
- AASHTO. 2002. *Standard Specifications for Highway Bridges and Interim Specifications*, 17th Edition, HB-17. American Association of State Highway and Transportation Officials, Washington, DC.
- AASHTO. 2003. *Guide Specifications for Horizontally Curved Steel Girder Highway Bridges with Design Examples for I-Girder and Box-Girder Bridges*, Fourth Edition, GHC-4. American Association of State Highway and Transportation Officials, Washington, DC.
- AASHTO. 2010. *AASHTO LRFD Bridge Design Specifications*, PE Edition, LRFD-PE. American Association of State Highway and Transportation Officials, Washington, DC. Fifth Edition with 2010 Interim; U.S. customary units.
- AASHTO. 2011. *Guide Specifications for LRFD Seismic Bridge Design*, Second Edition, LRFDEIS-2. American Association of State Highway and Transportation Officials, Washington, DC.
- AASHTO. 2011. *The Manual for Bridge Evaluation*, Second Edition, MBE-2-M. American Association of State Highway and Transportation Officials, Washington, DC.
- AASHTO/AWS. 2010. *Bridge Welding Code*, BWC-6 (AASHTO/AWS D1.5M/D1.5:2010). American Association of State Highway and Transportation Officials and American Welding Society, Washington, DC.
- AASHTO/NSBA Steel Bridge Collaboration. 2003. *Guidelines for Design for Constructibility, G12.1*, NSBAGDC-2. American Association of State Highway and Transportation Officials, Washington, DC.

ACI. 2008. *Building Code Requirements for Structural Concrete*, 318-08. American Concrete Institute, Farmington Hills, MI.

AISC. 1963. *Manual of Steel Construction*, Sixth Edition. American Institute of Steel Construction, Chicago, IL.

AISC. 1988. *Load and Resistance Factor Design Specification for Structural Joints Using ASTM A325 or A490 Bolts*. American Institute of Steel Construction, Chicago, IL, June.

AISC. 1994. *Load and Resistance Factor Design Specification for Structural Joints Using ASTM A325 or A490 Bolts*. American Institute of Steel Construction, Chicago, IL.

AISC. 1999. *Load and Resistance Factor Design. LRFD Specification for Structural Steel Buildings and Commentary*, American Institute of Steel Construction, Chicago, IL, December 27, 1999.

AISC. 2001. *Manual of Steel Construction—Load and Resistance Factor Design*, Third Edition. American Institute of Steel Construction, Chicago, IL, November.

AISC. 2005. *Specification for Structural Steel Buildings*, ANSI/AISC 360-05. American Institute of Steel Construction, Chicago, IL.

AISC. 2005a. *Steel Construction Manual*, 13th Edition. American Institute of Steel Construction, Chicago, IL.

AISC. 2005b. *Seismic Provisions for Structural Steel Buildings*. American Institute of Steel Construction, Chicago, IL.

AISI. 1969. *Specification for the Design of Cold-Formed Steel Structural Members*. American Iron and Steel Institute, Washington, DC.

AISI. 1975. *The Development of AASHTO Fracture-Toughness Requirements for Bridge Steels*. American Iron and Steel Institute, Washington, DC, February.

ASCE. 1968. "Design of Hybrid Steel Beams." Joint ASCE–AASHTO Subcommittee on Hybrid Beams and Girders. *Journal of the Structural Division*, American Society of Civil Engineers, Vol. 94, No. ST6., New York, NY.

ASCE. 1971. *Plastic Design in Steel—A Guide and Commentary*, Second Edition, ASCE Manual No. 41. American Society of Civil Engineers, New York, NY.

ASCE. 2000. *Design of Latticed Steel Transmission Towers*, ASCE 10-97. American Society of Civil Engineers, Reston, VA.

Aslani, F. and S. C. Goel. 1991. "An Analytical Criteria for Buckling Strength of Built-up Compression Members," *AISC Engineering Journal*. American Institute of Steel Construction, Chicago, IL, Vol. 28, No. 4, 4th Qtr., 1991, pp. 159–168.

Astaneh-Asl, A., B. Bolt, K. M. McMullin, R. Donikian, D. Modjtahedi, and S. Cho. 1994. *Seismic Performance of Steel Bridges During the 1994 Northridge Earthquake*, Report UCB/CESTEEL-94/01. Department of Civil Engineering, University of California at Berkeley, Berkeley, CA.

Astaneh-Asl, A., and R. Donikian. 1995. *Seismic Behavior and Design of Steel Bridges, Volume I—Response Modification Factor Based Design*. American Iron and Steel Institute, Washington, DC.

Astaneh-Asl, A., S. C. Goel, and R. D. Hanson. 1985. "Cyclic Out-of-Plane Buckling of Double Angle Bracing," *Journal of Structural Engineering*. American Society of Civil Engineers, New York, NY, Vol. 111, No. 5.

ASTM. 2001. *Standard Specifications for Carbon and High-Strength Low-Alloy Structural Steel Shapes, Plates and Bars and Quenched-and-Tempered Alloy Structural Steel Plates for Bridges*, ASTM A709/A709M – 01b^{e3}. American Society for Testing and Materials, West Conshohocken, PA.

Bahrami, H., A. M. Itani, and I. G. Buckle. 2010. *Guidelines for the Seismic Design of Ductile End Cross-Frames in Steel Girder Bridge Superstructures*, Report No. CCEER 09-04. Center for Civil Engineering Earthquake Research, University of Nevada, Reno, NV.

Baldwin, J. W., H. J. Salame, and R. C. Duffield. 1987. *Fatigue Test of a Three-Span Composite Highway Bridge*, Report 73-1. Department of Civil Engineering, University of Missouri, Columbia, MO, June.

- Barker, M. G., B. A. Hartnagel, C. G. Schilling, and B. E. Dishongh. 1997. *Inelastic Design and Experimental Testing of Compact and Noncompact Steel Girder Bridges*, Report 93-1. Missouri Cooperative Highway Research Program.
- Barth, K. E., B. A. Hartnagel, D. W. White, and M. G. Barker. 2004. "Improved Simplified Inelastic Design of Steel I-Girder Bridges," *Journal of Bridge Engineering*. American Society of Civil Engineers, Reston, VA, Vol. 9, No. 3.
- Barth, K. E., D. W. White, J. E. Righman, and L. Yang. 2005. "Evaluation of Web Compactness Limits for Singly and Doubly Symmetric Steel I-Girders," *Journal of Constructional Steel Research*. Elsevier, Orlando, FL, Vol. 61, No. 10.
- Basler, K. 1961. "Strength of Plate Girders in Shear," *Journal of the Structural Division*. American Society of Civil Engineers, New York, NY, Vol. 87, No. ST7, October, pp. 151–180.
- Basler, K., and B. Thurlimann. 1961. "Strength of Plate Girders in Bending," *Journal of the Structural Division*. American Society of Civil Engineers, New York, NY, Vol. 87, No. ST6, August, pp. 153–181.
- Basler, K., B. T. Yen, J. A. Mueller, and B. Thurlimann. 1960. "Web Buckling Tests on Welded Plate Girders," *WRC Bulletin No. 64*. Welding Research Council, New York, NY.
- Birkemoe, P. C., and M. I. Gilmour. 1978. "Behavior of Bearing Critical Double-Angle Beam Connections," *AISC Engineering Journal*. American Institute of Steel Construction, Chicago, IL, Vol. 15, No. 4, 4th Qtr., pp. 109–115.
- Birkemoe, P. C., and D. C. Herrschaft. 1970. "Bolted Galvanized Bridges: Engineering Acceptance Near," *Civil Engineering*. American Society of Civil Engineers, New York, NY, Vol. 40, No. 4, April, pp. 42–46.
- Bleich, F. 1952. *Buckling Strength of Metal Structures*. McGraw-Hill, New York, NY.
- Blodgett, O. W. 1982. *Design of Welded Structures*. The James F. Lincoln Arc Welding Foundation, Cleveland, OH, pp. 4.4-1–4.4-7.
- Boresi, A. P., O. M. Sidebottom, F. B. Seely, and J. O. Smith. 1978. *Advanced Mechanics of Materials*, Third Edition. John Wiley and Sons, New York, NY.
- Brockenbrough, R. L. 1983. "Considerations in the Design of Bolted Joints for Weathering Steel," *AISC Engineering Journal*. American Institute of Steel Construction, Chicago, IL, Vol. 20, 1st Qtr., pp. 40–45.
- Brockenbrough, R. L., and B. G. Johnston. 1981. *USS Steel Design Manual*. United States Steel Corporation, Pittsburgh, PA.
- Brown, J. D., D. J. Lubitz, Y. C. Cekov, and K. H. Frank. 2007. *Evaluation of Influence of Hole Making Upon the Performance of Structural Steel Plates and Connections*, Report No. FHWA/TX-07/0-4624-1. University of Texas at Austin, Austin, TX.
- Bruneau, M., J. W. Wilson, and R. Tremblay. 1996. "Performance of Steel Bridges during the 1995 Hyogoken-Nanbu Earthquake," *Canadian Journal of Civil Engineering*. National Research Council on Canada, Ottawa, ON, Canada, Vol. 23, No. 3, pp. 678–713.
- California Department of Transportation (Caltrans). 2001. *Seismic Design Criteria (Version 1.2)*. California Department of Transportation, Sacramento, CA.
- California Department of Transportation (Caltrans). 2006. *Seismic Design Criteria (Version 1.4)*. California Department of Transportation, Sacramento, CA.
- Carden, L. P., A. M. Itani, and I. G. Buckle. 2002. "Composite Action in Steel Girder Bridge Superstructures Subjected to Transverse Earthquake Loading," *Transportation Research Record No. 1814*. Transportation Research Board, National Research Council, Washington, DC.
- Carden, L. P., A. M. Itani, and I. G. Buckle. 2005a. *Seismic Load Path in Steel Girder Bridge Superstructures*, Report No. CCEER 05-03. Center for Civil Engineering Earthquake Research, University of Nevada, Reno, NV.
- Carden, L. P., A. M. Itani, and I. G. Buckle. 2005b. *Seismic Performance of Steel Girder Bridge Superstructures with Ductile End Cross-Frames and Seismic Isolation*, Report No. CCEER 05-04. Center for Civil Engineering Earthquake Research, University of Nevada, Reno, NV.

- Carden, L. P., A. M. Itani, and I. G. Buckle. 2006. "Seismic Performance of Steel Girder Bridges with Ductile End Cross-Frames Using Single Angle X Braces," *Journal of Structural Engineering*. American Society of Civil Engineers, Reston, VA, Vol. 132, No. 3, pp. 329–337.
- Carden, L. P., F. Garcia-Alvarez, A. M. Itani, and I. G. Buckle. 2006. "Cyclic Behavior of Single Angles for Ductile End Cross-Frames," *Engineering Journal*. American Institute of Steel Construction, Chicago, IL.
- Carskaddan, P. S. 1980. *Autostress Design of Highway Bridges—Phase 3: Interior-Support-Model Test*. Research Laboratory Report. United States Steel Corporation, Monroeville, PA, February.
- Carskaddan, P. S., and C. G. Schilling. 1974. *Lateral Buckling of Highway Bridge Girders*, Research Laboratory Report 22-G-001 (019-3). United States Steel Corporation, Monroeville, PA.
- CEN. 1992. *Eurocode 3: Design of Steel Structures*, EN 1993-1-9. European Committee for Standardization, Brussels, Belgium, Part 1-9: Fatigue Strength.
- CEN. 2004. *Eurocode 4: Design of Composite Steel and Concrete Structures*, EN 1994-1-1. European Committee for Standardization, Brussels, Belgium, Part 1-1: General—Common Rules and Rules for Buildings.
- Chesson, E., N. L. Faustino, and W. H. Munse. 1965. "High-Strength Bolts Subjected to Tension and Shear," *Journal of the Structural Division*. American Society of Civil Engineers, New York, NY, Vol. 91, No. ST5, October, pp. 55–180.
- Connor, R. J. and J. W. Fisher. 2004. *Results of Field Measurements Made on the Prototype Orthotropic Deck on the Bronx-Whitestone Bridge—Final Report*, ATLSS Report No. 04-03. Center for Advanced Technology for Large Structural Systems, Lehigh University, Bethlehem PA.
- Cooper, P. B. 1967. "Strength of Longitudinally Stiffened Plate Girders," *Journal of the Structural Division*. American Society of Civil Engineers, New York, NY, Vol. 93, ST2, April, pp. 419–451.
- Csagoly, P. F., B. Bakht, and A. Ma. 1975. *Lateral Buckling of Pony Truss Bridges*, R & D Branch Report RR-199. Ontario Ministry of Transportation and Communication, Downsview, Ontario, Canada, October.
- Culver, C. G. 1972. *Design Recommendations for Curved Highway Bridges*, Final Report for PennDOT Research Project 68-32. Civil Engineering Department, Carnegie–Mellon University, Pittsburgh, PA, June.
- Dabrowski, R. 1968. *Curved Thin-Walled Girders*, Translation No. 144. Cement and Concrete Association, London, England, p. 12.
- Davidson, J. S., M. A. Keller, and C. H. Yoo. 1996. "Cross-Frame Spacing and Parametric Effects in Horizontally Curved I-Girder Bridges," *Journal of Structural Engineering*. American Society of Civil Engineers, Vol. 122, No. 9, September, New York, NY, pp. 1089–1096.
- Davisson, M. T., F. S. Manuel, and R. M. Armstrong. 1983. *Allowable Stresses in Piles*, FHWA/RD-83/059. Federal Highway Administration, U.S. Department of Transportation, Washington, DC, December.
- Dexter, R. T., J. E. Tarquinio, and J. W. Fisher. 1994. Application of Hot Spot Stress Fatigue Analysis to Attachments on Flexible Plate. In *Proc., 13th International Conference on Offshore Mechanics and Arctic Engineering*. ASME, New York, NY, Vol. III, Material Engineering, pp. 85–92.
- Dicleli, M., and M. Bruneau. 1995a. "Seismic Performance of Multispan Simply Supported Slab-on-Girder Highway Bridges," *Engineering Structures*, Elsevier, Vol. 17, No. 1, pp. 4–14.
- Dicleli, M., and M. Bruneau. 1995b. "Seismic Performance of Simply Supported and Continuous Slab-on-Girder Steel Bridges," *Journal of Structural Engineering*. American Society of Civil Engineers, Reston, VA, Vol. 121, No. 10, pp. 1497–1506.
- Dowswell, B. 2002. "Lateral-Torsional Buckling of Wide Flange Cantilever Beams." *Proceedings of the 2002 Annual Stability Conference*. Structural Stability Research Council, University of Missouri, Rolla, MO, pp. 267–290.
- Douty, R. T., and W. McGuire. 1965. "High-Strength Bolted Moment Connections," *Journal of the Structural Division*. American Society of Civil Engineers, New York, NY, Vol. 91, No. ST2, April, pp. 101–128.

- Duan, L., M. Reno, and L. Lynch. 2000. "Section Properties for Latticed Members of San Francisco-Oakland Bay Bridges," *Journal of Bridge Engineering*. American Society of Civil Engineers, Reston, VA, Vol. 4, No. 2, May, pp. 156–164.
- Duan, L., M. Reno, and C. M. Uang. 2002. "Effect of Compound Buckling on Compression Strength of Built-Up Members," *AISC Engineering Journal*. American Institute of Steel Construction, Chicago, IL, Vol. 39, No. 1, 1st Qtr., 2002, pp. 30–37.
- Dubas, C. 1948. *A Contribution to the Buckling of Stiffened Plates*. IABSE Preliminary Publication. Third Congress, International Association for Bridge and Structural Engineers, Zurich, Switzerland.
- El Darwish, I. A., and B. G. Johnston. 1965. "Torsion of Structural Shapes," *Journal of the Structural Division*. American Society of Civil Engineers, New York, NY, Vol. 91, No. ST1, February.
- Elgaaly, M., and R. Salkar. 1991. "Web Crippling Under Edge Loading," *Proceedings of AISC National Steel Construction Conference*. Washington, DC, pp. 7-1–7-21.
- Ellifritt, D. S., G. Wine, T. Sputo, and S. Samuel. 1992. "Flexural Strength of WT Sections," *Engineering Journal*. American Institute of Steel Construction, Chicago, IL, Vol. 29, No. 2, 2nd Qtr.
- El-Tayem, A., and S. C. Goel. 1986. "Effective Length Factor for the Design of X-Bracing Systems," *AISC Engineering Journal*. American Institute of Steel Construction, Chicago, IL, Vol. 23, No. 1, 1st Qtr.
- Fan Z., and T. A. Helwig. 1999. "Behavior of Steel Box Girders with Top Flange Bracing," *Journal of Structural Engineering*. American Society of Civil Engineers, Reston, VA, Vol. 125, No. 8, August, pp. 829–837.
- FHWA. 1980. "Proposed Design Specifications for Steel Box Girder Bridges." *FHWA-TS-80-205*. Federal Highway Administration, Washington, DC.
- FHWA. 1989. *Technical Advisory on Uncoated Weathering Steel in Structures*. Federal Highway Administration, U.S. Department of Transportation, Washington, DC, October.
- FHWA. 2012. *Manual for Design, Construction and Maintenance of Orthotropic Steel Deck Bridges*. Federal Highway Administration, U.S. Department of Transportation, Washington, DC.
- Fisher, J. W., J. Jin, D. C. Wagner, and B. T. Yen. 1990. *Distortion-Induced Fatigue Cracking in Steel Bridges*, NCHRP Report 336. Transportation Research Board, National Research Council, Washington, DC, December.
- Foehl, P. J. 1948. "Direct Method of Designing Single Angle Struts in Welded Trusses," *Design Book for Welding*. Lincoln Electric Company, Cleveland, OH.
- Frank, K. H., and J. W. Fisher. 1979. "Fatigue Strength of Fillet Welded Cruciform Joints," *Journal of the Structural Division*. American Society of Civil Engineers, New York, NY, Vol. 105, No. ST9, September, pp. 1727–1740.
- Frank, K. H., and T. A. Helwig. 1995. "Buckling of Webs in Unsymmetric Plate Girders," *AISC Engineering Journal*. American Institute of Steel Construction, Chicago, IL, Vol. 32, 2nd Qtr., pp. 43–53.
- Frank, K. H., and J. A. Yura. 1981. *An Experimental Study of Bolted Shear Connections*, FHWA/RD-81/148. Federal Highway Administration, U.S. Department of Transportation, Washington, DC, December.
- Frost, R. W., and C. G. Schilling. 1964. "Behavior of Hybrid Beams Subjected to Static Loads," *Journal of the Structural Division*. American Society of Civil Engineers, New York, NY, Vol. 90, No. ST3, June, pp. 55–88.
- Galambos, T. V., ed. 1998. *Guide to Stability Design Criteria for Metal Structures*, Fifth Edition. Structural Stability Research Council, John Wiley and Sons, Inc., New York, NY.
- Galambos, T. V. 2006. "Reliability of the Member Stability Criteria in the 2005 AISC Specification," *Engineering Journal*. AISC, Fourth Quarter, 257–265.
- Galambos, T. V., and J. Chapuis. 1980. *LRFD Criteria for Composite Columns and Beam Columns*. Revised draft. Washington University Department of Civil Engineering, St. Louis, MO, December.

Galambos, T. V., R. T. Leon, C. E. French, M. G. Barker, and B. E. Dishongh. 1993. *Inelastic Rating Procedures for Steel Beam and Girder Bridges*, NCHRP Report 352, Transportation Research Board, National Research Council, Washington, DC.

Gaylord, E.H. 1963. "Discussion of K. Basler 'Strength of Plate Girders in Shear,'" *Transaction ASCE*. American Society of Civil Engineers, New York, NY, Vol. 128 No. II, pp. 712–719.

Goldberg, J. E., and H. L. Leve. 1957. "Theory of Prismatic Folded Plate Structures," *IABSE*. International Association for Bridge and Structural Engineers, Zurich, Switzerland, Vol. 16, pp. 59–86.

Graham, J. D., A. N. Sherbourne, R. N. Khabbaz, and C. D. Jensen. 1959. *Welded Interior Beam-to-Column Connections*. American Institute of Steel Construction, New York, NY.

Grubb, M. A. 1993. "Review of Alternate Load Factor (Autostress) Design," *Transportation Research Record 1380*. Transportation Research Board, National Research Council, Washington, DC, pp. 45–48.

Grubb, M. A., and R. E. Schmidt. 2004. *Three-Span Continuous Straight Composite I Girder, Load and Resistance Factor Design*, Third Edition—Customary U.S. Units. Available from the National Steel Bridge Alliance, Chicago, IL, pp. C1–C5.

Haaijer, G. 1981. "Simple Modeling Technique for Distortion Analysis for Steel Box Girders." *Proceedings of the MSC/NASTRAN Conference on Finite Element Methods and Technology*. MacNeal/Schwendler Corporation, Los Angeles, CA.

Haaijer, G., P. S. Carskaddan, and M. A. Grubb. 1987. "Suggested Autostress Procedures for Load Factor Design of Steel Beam Bridges," *AISI Bulletin*. American Iron and Steel Institute, Washington, DC, No. 29, April.

Hall, D. H., and C. H. Yoo. 1996. *I-Girder Curvature Study*. Interim Report, NCHRP Project 12-38. Submitted to NCHRP, Transportation Research Board, Washington, DC, pp. 1–72 (or see Appendix A of NCHRP Report 424, *Improved Design Specifications for Horizontally Curved Steel Highway Bridges*, pp. 49–74).

Hanshin Expressway Public Corporation and Steel Structure Study Subcommittee. 1988. *Guidelines for the Design of Horizontally Curved Girder Bridges (Draft)*. Hanshin Expressway Public Corporation, October, pp. 1–178.

Heins, C. P. 1975. *Bending and Torsional Design in Structural Members*. Lexington Books, D. C. Heath and Company, Lexington, MA, pp. 17–24.

Heins, C. P. 1978. "Box Girder Bridge Design—State of the Art." *AISC Engineering Journal*, American Institute of Steel Construction, Chicago, IL, 4th Qrt., pp. 126–142.

Heins, C.P., and D. H. Hall. 1981. *Designer's Guide to Steel Box-Girder Bridges*, Booklet No. 3500, Bethlehem Steel Corporation, Bethlehem, PA, pp. 20–30.

Helwig, T. A., K. H. Frank, and J. A. Yura. 1997. "Lateral-Torsional Buckling of Singly Symmetric I-Beams," *Journal of Structural Engineering*. American Society of Civil Engineers, New York, NY, Vol. 123, No. 9, pp. 1172–1179.

Horne, M. R. and W. R. Grayson. 1983. "Parametric Finite Element Study of Transverse Stiffeners for Webs in Shear. Instability and Plastic Collapse of Steel Structures." In *Proc., the Michael R. Horne Conference*, L. J. Morris, ed., Granada Publishing, London, pp. 329–341.

Horne, M. R. and R. Narayanan. 1977. "Design of Axially Loaded Stiffened Plates," *ASCE Journal of the Structural Division*. American Society of Civil Engineers, Reston, VA, Vol. 103, ST11, pp. 2243–2257.

Huhn, H., and G. Valtinat. 2004. "Bolted Connections with Hot Dip Galvanized Steel Members with Punched Holes." *Proceedings of the ECCS/AISC Workshop, Connections in Steel Structures V: Innovative Steel Connections*, June 3–5, 2004. European Convention for Constructional Steelwork/American Institute of Steel Construction, Amsterdam.

IIW. 2007. *Recommendations for Fatigue Design of Welded Joints and Components*, doc. XII-1965-03/XV-1127-03. International Institute of Welding, Paris, France.

Itani, A. M. 1995. Cross-Frame Effect on Seismic Behavior of Steel Plate Girder Bridges. In *Proc., Annual Technical Session*, Structural Stability Research Council, Kansas City, MO. University of Missouri, Rolla, MO.

- Itani, A. M., M. A. Grubb, and E. V. Monzon. 2010. *Proposed Seismic Provisions and Commentary for Steel Plate Girder Superstructures*, Report No. CCEER 10-03. Center of Civil Engineering Earthquake Research, University of Nevada, Reno, NV. With design examples.
- Itani, A. M., and M. Reno. 1995. Seismic Design of Modern Steel Highway Connectors, In *Proc., ASCE Structures Congress XIII*, Boston, MA. American Society of Civil Engineers, Reston, VA.
- Itani, A. M., and P. P. Rimal. 1996. "Seismic Analysis and Design of Modern Steel Highway Bridges," *Earthquake Spectra*. Earthquake Engineering Research Institute, Volume 12, No. 2.
- Itani, A. M., and H. Sedarat. 2000. *Seismic Analysis and Design of the AISI LRFD Design Examples of Steel Highway Bridges*, Report N. CCEER 00-08. Center for Civil Engineering Earthquake Research, University of Nevada, Reno, NV.
- Johnson, D. L. 1985. "An Investigation into the Interaction of Flanges and Webs in Wide Flange Shapes." *Proceedings SSRC Annual Technical Session*, Cleveland, OH, Structural Stability Research Council, Gainesville, FL.
- Johnston, B. G., and G. G. Kubo. 1941. *Web Crippling at Seat Angle Supports*, Fritz Engineering Laboratory, Report No. 192A2, Lehigh University, Bethlehem, PA.
- Johnston, S. B., and A. H. Mattock. 1967. "Lateral Distribution of Load in Composite Box Girder Bridges," *Highway Research Record*. Bridges and Structures, Transportation Research Board, National Research Council, Washington, DC, No. 167.
- Jung, S. K., and D. W. White. 2006. "Shear Strength of Horizontally Curved Steel I-Girders—Finite Element Studies," *Journal of Constructional Steel Research*. Vol. 62, No. 4, pp. 329–342.
- Kanchanalai, T. 1977. *The Design and Behavior of Beam-Columns in Unbraced Steel Frames*, AISI Project No. 189, Report No. 2. American Iron and Steel Institute, Washington, DC, Civil Engineering/Structures Research Lab, University of Texas, Austin, TX, October.
- Kaufmann, E. J., R. J. Connor, and J. W. Fisher. 2004. *Failure Investigation of the SR 422 over the Schuylkill River Girder Fracture—Draft Final Report*. ATLSS Engineering Research Center, Lehigh University, Bethlehem, PA.
- Keating, P. B., ed. 1990. *Economical and Fatigue Resistant Steel Bridge Details*, FHWA-H1-90-043. Federal Highway Administration, Washington, DC, U.S. Department of Transportation, Washington, DC, October.
- Ketchum, M. S. 1920. *The Design of Highway Bridges of Steel, Timber and Concrete*. McGraw–Hill Book Company, New York, NY, pp. 1–548.
- Kim, Y. D., S. K. Jung, and D. W. White. 2004. *Transverse Stiffener Requirements in Straight and Horizontally Curved Steel I-Girders*, Structural Engineering Report No. 36. School of Civil and Environmental Engineering, Georgia Institute of Technology, Atlanta, GA.
- Kitipornchai, S., and N. S. Trahair. 1980. "Buckling Properties of Monosymmetric I-Beams," *Journal of the Structural Division*. American Society of Civil Engineers, New York, NY, Vol. 106, No. ST5, May, pp. 941–957.
- Kitipornchai, S., and N. S. Trahair. 1986. "Buckling of Monosymmetric I-Beams under Moment Gradient," *Journal of Structural Engineering*. American Society of Civil Engineers, New York, NY, Vol. 112, No. 4, pp. 781–799.
- Kollbrunner, C., and K. Basler. 1966. *Torsion in Structures*. Springer–Verlag, New York, NY, pp. 19–21.
- Kolstein, M. H. 2007. *Fatigue Classification of Welded Joints in Orthotropic Steel Bridge Decks*, Ph.D. Dissertation, ISBN 978-90-9021933-2. Delft University of Technology. The Netherlands.
- Kulak, G. L., and G. Y. Grondin. 2001. "AISC LRFD Rules for Block Shear—A Review" *AISC Engineering Journal*. American Institute of Steel Construction, Chicago, Vol. 38, No. 4, Qtr. 4th, pp. 199–203.
- Kulak, G. L., J. W. Fisher, and J. H. A. Struik. 1987. *Guide to Design Criteria for Bolted and Riveted Joints*, Second Edition. John Wiley and Sons, Inc. New York, NY.
- Kulicki, J. M. 1983. "Load Factor Design of Truss Bridges with Applications to Greater New Orleans Bridge No. 2," *Transportation Research Record 903*. Transportation Research Board, National Research Council, Washington, DC.

- Lee, S. C., C. H. Yoo, and D. Y. Yoon. 2003. "New Design Rule for Intermediate Transverse Stiffeners Attached on Web Panels," *Journal of Structural Engineering*. American Society of Civil Engineers, New York, NY, Vol. 129, No. 12, pp. 1607–1614.
- Lew, H. S., and A. A. Toprac. 1968. *Static Strength of Hybrid Plate Girders*, SFRL Technical Report. University of Texas, Austin, TX.
- Lutz, L. A. 1992. "Critical Slenderness of Compression Members with Effective Lengths about Non-Principal Axes." *Proceedings of the Annual Technical Session and Meeting*, Pittsburgh, PA, Structural Stability Research Council, University of Missouri, Rolla, MO.
- Lutz, L. A. 1996. "A Closer Examination of the Axial Capacity of Eccentrically Loaded Single Angle Struts," *AISC Engineering Journal*. American Institute of Steel Construction, Chicago, IL, Vol. 33, No. 2, 2nd Qtr.
- Lutz, L. A. 1998. "Toward a Simplified Approach for the Design of Web Members in Trusses." *Proceedings of the Annual Technical Session and Meeting*. Atlanta, GA, Structural Stability Research Council, University of Missouri, Rolla, MO, September 21–23.
- Lutz, L. A. 2006. "Evaluating Single Angle Compression Struts Using an Effective Slenderness Approach," *AISC Engineering Journal*. American Institute of Steel Construction, Chicago, IL, Vol. 43, No. 4, 4th Qtr.
- Mahmoud, H. N., R. J. Connor, and J. W. Fisher. 2005. "Finite Element Investigation of the Fracture Potential of Highly Constrained Details," *Journal of Computer-Aided Civil and Infrastructure Engineering*. Blackwell Publishing, Inc., Malden, MA, Vol. 20.
- McDonald, G. S., and K. H. Frank. 2009. *The Fatigue Performance of Angle Cross-Frame Members in Bridges*, Ferguson Structural Engineering Laboratory Report FSEL No: 09-1. University of Texas at Austin, Austin, TX.
- McGuire, W. 1968. *Steel Structures*. Prentice-Hall, Inc., Englewood Cliffs, NJ.
- Mengelkoch, N. S., and J. A. Yura. 2002. "Single-Angle Compression Members Loaded Through One Leg," *Proceedings of the Annual Technical Session and Meeting*. Seattle, WA, Structural Stability Research Council, University of Missouri, Rolla, MO, April 24–27.
- Moses, F., C. G. Schilling, and K. S. Raju. 1987. *Fatigue Evaluation Procedures for Steel Bridges*, NCHRP Report 299. Transportation Research Board, National Research Council, Washington, DC, November.
- Mouras, J. M., J. P. Sutton, K. H. Frank, and E. B. Williamson. 2008. *The Tensile Capacity of Welded Shear Studs*, Report 9-5498-R2. Center for Transportation Research at the University of Texas, Austin, TX.
- Mozer, J. and C. G. Culver. 1970. *Horizontally Curved Highway Bridges: Stability of Curved Plate Girders*, Report No. P1. Prepared for Federal Highway Administration, U.S. Department of Transportation, August, p. 95.
- Mozer, J., R. Ohlson, and C. G. Culver. 1971. *Horizontally Curved Highway Bridges: Stability of Curved Plate Girders*, Report No. P2. Prepared for Federal Highway Administration, U.S. Department of Transportation, September, p. 121.
- MCEER and ATC. 2003. *Recommended LRFD Guidelines for Seismic Design of Highway Bridges*. Applied Technology Council / Multidisciplinary Center for Earthquake Engineering Research Joint Venture, Redwood City, CA, Parts I and II.
- Nair, R. S., P. C. Birkemoe, and W. H. Munse. 1974. "High-Strength Bolts Subjected to Tension and Prying," *Journal of the Structural Division*. American Society of Civil Engineers, New York, NY, Vol. 100, No. ST2, February, pp. 351–372.
- Nethercot, D. A., and N. S. Trahair. 1976. "Lateral Buckling Approximations for Elastic Beams," *The Structural Engineer*, Vol. 54, No. 6, pp. 197–204.
- NCHRP. 2002. *Comprehensive Specification for the Seismic Design of Bridges*, NCHRP Report 472. Transportation Research Board, National Research Council, Washington, DC.
- NCHRP. 2006. *Recommended LRFD Guidelines for the Seismic Design of Highway Bridges*, Report NCHRP Project 20-07, Task 193. Transportation Research Board, National Research Council, Washington, DC.

- NHI. 2011. "Design Criteria for Arch and Cable Stayed Signature Bridges," *Reference Manual for NHI Course No. 130096*, FHWA-NHI-11-023. National Highway Institute, Federal Highways Administration, U.S. Department of Transportation, Washington, D.C.
- NSBA. 1996. "Composite Box Girder," *Highway Structures Design Handbook*, Second Edition. National Steel Bridge Alliance, Chicago, IL, Chapter II/7.
- Ollgaard, J. G., R. G. Slutter, and J. W. Fisher. 1971. "Shear Strength of Stud Connectors in Lightweight and Normal Weight Concrete," *AISC Engineering Journal*. American Institute of Steel Construction, Chicago, IL, Vol. 8, No. 2, April, p. 55.
- Owen, D. R. J., K. C. Rockey, and M. Skaloud. 1970. *Ultimate Load Behaviour of Longitudinally Reinforced Webplates Subjected to Pure Bending*. IASBE Publications, Vol. 30-I, pp. 113–148.
- Polyzois, D., and K. H. Frank. 1986. "Effect of Overspray and Incomplete Masking of Faying Surfaces on the Slip Resistance of Bolted Connections," *AISC Engineering Journal*. American Institute of Steel Construction, Chicago, IL, Vol. 23, 2nd Qtr., pp. 65–69.
- Rahal, K. N. and J. E. Harding. 1990. Transversely Stiffened Girder Webs Subjected to Shear Loading—Part 1: Behaviour. *Proceedings of the Institution of Civil Engineers*. Part 2, 89, March, pp. 47–65.
- Richardson, Gordon, and Associates (presently HDR Pittsburgh Office). 1976. "Curved Girder Workshop Lecture Notes." Prepared under Contract No. DOT-FH-11-8815, Federal Highway Administration. The four-day workshop was presented in Albany, Denver and Portland during September–October 1976.
- Ricles, J. M., and J. A. Yura. 1983. "Strength of Double-Row Bolted Web Connections," *Journal of the Structural Division*. American Society of Civil Engineers, New York, NY, Vol. 109, No. ST1, January, pp. 126–142.
- Roberts, J. E. 1992. "Sharing California's Seismic Lessons," *Modern Steel Construction*. American Institute of Steel Construction, Chicago, IL, pp. 32–37.
- Roberts, T. M. 1981. Slender Plate Girders Subjected to Edge Loading. *Proceedings, Institution of Civil Engineers*, Part 2, 71, London.
- Roeder, C. W., and L. Eltvik. 1985. "An Experimental Evaluation of Autostress Design," *Transportation Research Record 1044*. Transportation Research Board, National Research Council, Washington, DC.
- Salmon, C. G., and J. E. Johnson. 1996. *Steel Structures: Design and Behavior*, Fourth Edition. HarperCollins College Publishers, New York, NY.
- Schilling, C. G. 1968. "Bending Behavior of Composite Hybrid Beams," *Journal of the Structural Division*. American Society of Civil Engineers, New York, NY, Vol. 94, No. ST8, August, pp. 1945–1964.
- Schilling, C. G. 1986. *Exploratory Autostress Girder Designs*, Project 188 Report. American Iron and Steel Institute, Washington, DC.
- Schilling, C. G. 1986. "Fatigue." Chapter I/6. *Highway Structures Design Handbook*. American Institute of Steel Construction Marketing, Inc., Available from the National Steel Bridge Alliance, Chicago, IL, February.
- Schilling, C. G. 1990. *Variable Amplitude Load Fatigue—Volume I: Traffic Loading and Bridge Response*, FHWA-RD-87-059. Federal Highway Administration, Washington, DC, U.S. Department of Transportation, July.
- Schilling, C. G. 1996. "Yield-Interaction Relationships for Curved I-Girders," *Journal of Bridge Engineering*. American Society of Civil Engineers, New York, NY, Vol. 1, No. 1, pp. 26–33.
- Schilling, C. G., M. G. Barker, B. E. Dishongh, and B. A. Hartnagel. 1997. *Inelastic Design Procedures and Specifications*. Final Report submitted to the American Iron and Steel Institute, Washington, DC.
- Seaburg, P. A., and C. J. Carter. 1997. *Torsional Analysis of Structural Steel Members*, Steel Design Guide Series No. 9, American Institute of Steel Construction, Chicago, IL.
- Sheikh-Ibrahim, F. I. 2002. "Design Method for the Bolts in Bearing-Type Connections with Fillers," *AISC Engineering Journal*. American Institute of Steel Construction, Chicago, IL, Vol. 39, No. 4, pp. 189–195.

- Sheikh-Ibrahim, F. I., and K. H. Frank. 1998. "The Ultimate Strength of Symmetric Beam Bolted Splices," *AISC Engineering Journal*, American Institute of Steel Construction, Chicago, IL, Vol. 35, No. 3, 3rd Qtr., pp. 106–118.
- Sheikh-Ibrahim, F. I., and K. H. Frank. 2001. "The Ultimate Strength of Unsymmetric Beam Bolted Splices," *AISC Engineering Journal*. American Institute of Steel Construction, Chicago, IL, Vol. 38, No. 2, 2nd Qtr., pp. 100–117.
- Sherman, D. R. 1976. "Tentative Criteria for Structural Applications of Steel Tubing and Pipe." American Iron and Steel Institute, Washington, DC.
- Sherman, D. R. 1992. "Tubular Members." *Constructional Steel Design—An International Guide*, Dowling, P. J., J. H. Harding, and R. Bjorhovde (eds.). Elsevier Applied Science, London, United Kingdom.
- Sim, H. and C. Uang. 2007. *Effects of Fabrication Procedures and Weld Melt-Through on Fatigue Resistance of Orthotropic Steel Deck Welds*, Report No. SSRP-07/13. University of California, San Diego. August.
- Slutter, R. G., and G. C. Driscoll, Jr. 1965. "Flexural Strength of Steel-Concrete Composite Beams," *Journal of the Structural Division*. American Society of Civil Engineers, New York, NY, Vol. 91, No. ST2, April, pp. 71–99.
- Slutter, R. G., and J. W. Fisher. 1966. "Fatigue Strength of Shear Connectors," *Highway Research Record No. 147*. Highway Research Board, Washington, DC.
- SSRC (Structural Stability Research Council) Task Group 20. 1979. "A Specification for the Design of Steel Concrete Composite Columns," *AISC Engineering Journal*. American Institute of Steel Construction, Chicago, IL, Vol. 16, 4th Qtr., p. 101.
- SSRC (Structural Stability Research Council). 1998. *Guide to Stability Design Criteria for Metal Structures*, Fifth Edition. Galambos, T., ed., John Wiley and Sons, Inc., New York, NY.
- Stanway, G. S., J. C. Chapman, and P. J. Dowling. 1996. A Design Model for Intermediate Web Stiffeners. *Proceedings of the Institution of Civil Engineers, Structures and Buildings*. 116, February, pp. 54–68.
- Tide, R. H. R. 1985. "Reasonable Column Design Equations." Presented at Annual Technical Session of Structural Stability, Research Council, Gainesville, FL, April 16–17, 1985.
- Timoshenko, S. P., and J. M. Gere. 1961. *Theory of Elastic Stability*. McGraw-Hill, New York, NY.
- Trahair, N. S., T. Usami, and T. V. Galambos. 1969. "Eccentrically Loaded Single-Angle Columns," *Research Report No. 11*. Civil and Environmental Engineering Department, Washington University, St. Louis, MO.
- Troitsky, M. S. 1977. *Stiffened Plates, Bending, Stability, and Vibrations*. Elsevier, New York, NY.
- Ugural, A.C., and Fenster, S.K. 1978. *Advanced Strength and Applied Elasticity*. Elsevier North Holland Publishing Co., Inc., New York, NY, pp. 105–107.
- United States Steel. 1978. *Steel/Concrete Composite Box-Girder Bridges: A Construction Manual*. Available from the National Steel Bridge Alliance, Chicago, IL, December.
- United States Steel. 1984. *V-Load Analysis*. Vol. 1, Chapter 12 of *Highway Structures Design Handbook*. Available from the National Steel Bridge Alliance, Chicago, IL, pp. 1–56.
- Usami, T., and T. V. Galambos. 1971. "Eccentrically Loaded Single-Angle Columns." International Association for Bridge and Structural Engineering, Zurich, Switzerland.
- Vincent, G. S. 1969. "Tentative Criteria for Load Factor Design of Steel Highway Bridges," *AISI Bulletin*. American Iron and Steel Institute, Washington, DC, No. 15, March.
- Wattar, F., P. Albrecht, and A. H. Sahli. 1985. "End-Bolted Cover Plates," *Journal of the Structural Division*. American Society of Civil Engineers, New York, NY, Vol 3, No. 6, June, pp. 1235–1249.
- White, D. W. 2004. "Unified Flexural Resistance Equations for Stability Design of Steel I-Section Members—Overview," *Structural Engineering, Mechanics and Materials Report No. 24a*. School of Civil and Environmental Engineering, Georgia Institute of Technology, Atlanta, GA.

- White, D. W. 2006. "Structural Behavior of Steel," *Structural Engineering, Mechanics and Materials Report No. 51*. School of Civil and Environmental Engineering, Georgia Institute of Technology, Atlanta, GA.
- White, D. W., B. W. Shafer, and S.-C. Kim. 2006. "Implications of the AISC (2205) Q-Factor Equations for Rectangular Box and I-Section Members," *Structural Mechanics and Materials Report*. Georgia Institute of Technology, Atlanta, GA.
- White, D. W., and M. Barker. 2004. "Shear Resistance of Transversely-Stiffened Steel I-Girders," *Structural Engineering, Mechanics and Materials Report No. 26*. School of Civil and Environmental Engineering, Georgia Institute of Technology, Atlanta, GA.
- White, D. W., M. Barker, and A. Azizinamini. 2004. "Shear Strength and Moment-Shear Interaction in Transversely-Stiffened Steel I-Girders," *Structural Engineering, Mechanics and Materials Report No. 27*. School of Civil and Environmental Engineering, Georgia Institute of Technology, Atlanta, GA.
- White, D. W., and K. E. Barth. 1998. "Strength and Ductility of Compact-Flange I Girders in Negative Bending," *Journal of Constructional Steel Research*. Vol. 45, No. 3, pp. 241–280.
- White, D. W., and M. A. Grubb. 2005. "Unified Resistance Equations for Design of Curved and Tangent Steel Bridge I-Girders." *Proceedings of the 2005 TRB Bridge Engineering Conference*, Transportation Research Board, Washington, DC, July.
- White, D. W. and Jung, S.-K. 2003. "Simplified Lateral-Torsional Buckling Equations for Singly-Symmetric I-Section Members," *Structural Engineering, Mechanics and Materials Report No. 24b*. School of Civil and Environmental Engineering, Georgia Institute of Technology, Atlanta, GA.
- White, D. W., J. A. Ramirez, and K. E. Barth. 1997. *Moment Rotation Relationships for Unified Autostress Design Procedures and Specifications*. Final Report, Joint Transportation Research Program, Purdue University, West Lafayette, IN.
- White, D. W., B. W. Shafer, and S.-C. Kim. 2006. *Implications of the AISC (2005) Q-Factor Equations for Rectangular Box and I-Section Members*, Structural Mechanics and Materials Report. Georgia Institute of Technology, Atlanta, GA.
- White, D. W., A. H. Zureick, N. Phoawanich, and S.-K. Jung. 2001. *Development of Unified Equations for Design of Curved and Straight Steel Bridge I Girders*. Final Report to American Iron and Steel Institute Transportation and Infrastructure Committee, Professional Services Industries, Inc., and Federal Highway Administration, School of Civil and Environmental Engineering, Georgia Institute of Technology, Atlanta, GA.
- Winter, G. 1947. "Strength of Thin Steel Compression Flanges," *Transactions of the ASCE*. American Society of Civil Engineers, Reston, VA, Vol. 112.
- Wittry, Dennis M. 1993. *An Analytical Study of the Ductility of Steel Concrete Composite Sections*. Masters Thesis. University of Texas, Austin, TX, December.
- Wolchuk, R. 1963. *Design Manual for Orthotropic Steel Plate Deck Bridges*. American Institute of Steel Construction, Chicago, IL.
- Wolchuck, R. 1997. "Steel-Plate-Deck Bridges and Steel Box Girder Bridges," *Structural Engineering Handbook*, Fourth Edition, E. H. Gaylord, Jr., C. N. Gaylord, and J. E. Stallmeyer, eds., McGraw-Hill, New York, NY, pp. 19-1–19-31.
- Woolcock, S. T., and S. Kitipornchai. 1986. "Design of Single-Angle Web Struts in Trusses," *Journal of Structural Engineering*. American Society of Civil Engineers, New York, NY, Vol. 112, No. ST6.
- Wright, R. N., and S. R. Abdel-Samad. 1968. "Analysis of Box Girders with Diaphragms," *Journal of the Structural Division*. American Society of Civil Engineers, New York, NY, Vol. 94, No. ST10, October, pp. 2231–2256.
- Wright, R. N., and S. R. Abdel-Samad. 1968. "BEF Analogy for Analysis of Box Girders," *Journal of the Structural Division*. American Society of Civil Engineers, New York, NY, Vol. 94, No. ST7, July.
- Wright, W. J., J. W. Fisher, and E. J. Kaufmann. 2003. "Failure Analysis of the Hoan Bridge Fractures," *Recent Developments in Bridge Engineering*, Mahmoud ed. Swets & Zeitlinger, Lisse.
- Xiao. 2008. *Effect of Fabrication Procedures and Weld Melt-Through on Fatigue Resistance of Orthotropic Steel Deck Welds*, Final Report No. CA08-0607. Department of Structural Engineering University of California, San Diego, CA.

- Yakel, A. J., and A. Azizinamini. 2005. "Improved Moment Strength Prediction of Composite Steel Plate Girder in Positive Bending," *Journal of Bridge Engineering*. American Society of Civil Engineers, Reston, VA, January/February.
- Yen, B. T., T. Huang, and D. V. VanHorn. 1995. *Field Testing of a Steel Bridge and a Prestressed Concrete Bridge*, Research Project No. 86-05, Final Report, Vol. II. Pennsylvania Department of Transportation Office of Research and Special Studies, Fritz Engineering Laboratory Report No. 519.2, Lehigh University, Bethlehem, PA, May.
- Yen, B. T., and J. A. Mueller. 1966. "Fatigue Tests of Large Size Welded Plate Girders," *WRC Bulletin*. No. 118, November.
- Yoo, C. H., and J. S. Davidson. 1997. "Yield Interaction Equations for Nominal Bending Strength of Curved I-Girders," *Journal of Bridge Engineering*. American Society of Civil Engineers, New York, NY, Vol. 2, No. 2, pp. 37–44.
- Yura, J. A., K. H. Frank, and D. Polyzois. 1987. *High-Strength Bolts for Bridges*, PMFSEL Report No. 87-3. University of Texas, Austin, TX, May.
- Yura, J. A., M. A. Hansen, and K. H. Frank. 1982. "Bolted Splice Connections with Undeveloped Fillers," *Journal of the Structural Division*. American Society of Civil Engineers, New York, NY, Vol. 108, No. ST12, December, pp. 2837–2849.
- Zahrai, S. M., and M. Bruneau. 1998. "Impact of Diaphragms on Seismic Response of Straight Slab-on-Girder Steel Bridges," *Journal of Structural Engineering*. American Society of Civil Engineers, Reston, VA, Vol. 124, No. 8, pp. 938–947.
- Zahrai, S. M., and M. Bruneau. 1999a. "Ductile End-Diaphragm for Seismic Retrofit of Slab-on-Girder Steel Bridges," *Journal of Structural Engineering*. American Society of Civil Engineers, Reston, VA, Vol. 125, No. 1, pp. 71–80.
- Zahrai, S. M., and M. Bruneau. 1999b. "Cyclic Testing of Ductile End-Diaphragms for Slab-on-Steel Girder Bridges," *Journal of Structural Engineering*. American Society of Civil Engineers, Reston, VA, Vol. 125, No. 9, pp. 987–996.
- Zandonini, R. 1985. "Stability of Compact Built-up Struts: Experimental Investigation and Numerical Simulation," *Costruzione Metalliche*. Milan, Italy, No. 4, 1985, pp. 202–224.
- Zureick, A. H., D. W. White, N. P. Phoawanich, and J. Park. 2002. *Shear Strength of Horizontally Curved Steel I-Girders—Experimental Tests*. Final Report to PSI Inc. and Federal Highway Administration, U.S. Department of Transportation, p. 157.

APPENDIX A6—FLEXURAL RESISTANCE OF STRAIGHT COMPOSITE I-SECTIONS IN NEGATIVE FLEXURE AND STRAIGHT NONCOMPOSITE I-SECTIONS WITH COMPACT OR NONCOMPACT WEBS

A6.1—GENERAL

These provisions shall apply only to sections in straight bridges whose supports are normal or skewed not more than 20 degrees from normal, and with intermediate diaphragms or cross-frames placed in contiguous lines parallel to the supports, that satisfy the following requirements:

- the specified minimum yield strengths of the flanges and web do not exceed 70.0 ksi,
- the web satisfies the noncompact slenderness limit:

$$\frac{2D_c}{t_w} < 5.7 \sqrt{\frac{E}{F_{yc}}} \quad (\text{A6.1-1})$$

and:

- the flanges satisfy the following ratio:

$$\frac{I_{yc}}{I_{yt}} \geq 0.3 \quad (\text{A6.1-2})$$

where:

- D_c = depth of the web in compression in the elastic range (in.). For composite sections, D_c shall be determined as specified in Article D6.3.1.
- I_{yc} = moment of inertia of the compression flange of the steel section about the vertical axis in the plane of the web (in.⁴)
- I_{yt} = moment of inertia of the tension flange of the steel section about the vertical axis in the plane of the web (in.⁴)

Otherwise, the section shall be proportioned according to the provisions specified in Article 6.10.8.

Sections designed according to these provisions shall qualify as either compact web sections or noncompact web sections determined as specified in Article A6.2.

CA6.1

The optional provisions of Appendix A6 account for the ability of compact and noncompact web I-sections to develop flexural resistances significantly greater than M_y when the web slenderness, $2D_c/t_w$, is well below the noncompact limit of Eq. A6.1-1, which is a restatement of Eq. 6.10.6.2.3-1, and when sufficient requirements are satisfied with respect to the flange specified minimum yield strengths, the compression-flange slenderness, $b_{fc}/2t_{fc}$, and the lateral brace spacing. These provisions also account for the beneficial contribution of the St. Venant torsional constant, J . This may be useful, particularly under construction situations, for sections with compact or noncompact webs having larger unbraced lengths for which additional lateral torsional buckling resistance may be required. Also, for heavy column shapes with $D/b_f < 1.7$, which may be used as beam-columns in steel frames, both the inelastic and elastic buckling resistances are heavily influenced by J .

The potential benefits of the Appendix A6 provisions tend to be small for I-sections with webs that approach the noncompact web slenderness limit of Eq. A6.1-1. For these cases, the simpler and more streamlined provisions of Article 6.10.8 are recommended. The potential gains in economy by using Appendix A6 increase with decreasing web slenderness. The Engineer should give strong consideration to utilizing Appendix A6 for sections in which the web is compact or nearly compact. In particular, the provisions of Appendix A6 are recommended for sections with compact webs, as defined in Article A6.2.1.

The provisions of Appendix A6 are fully consistent with and are a direct extension of the main procedures in Article 6.10.8 in concept and in implementation. The calculation of potential flexural resistances greater than M_y is accomplished through the use of the web plastification parameters R_{pc} and R_{pt} of Article A6.2, corresponding to flexural compression and tension, respectively. These parameters are applied much like the web bend-buckling and hybrid girder parameters R_b and R_h in the main specification provisions.

I-section members with a specified minimum yield strength of the flanges greater than 70.0 ksi are more likely to be limited by Eq. A6.1-1 and are likely to be controlled by design considerations other than the Strength Load Combinations in ordinary bridge construction. In cases where Eq. A6.1-1 is satisfied with $F_{yc} > 70.0$ ksi, the implications of designing such members in general using a nominal flexural resistance greater than M_y have not been sufficiently studied to merit the use of Appendix A6.

A6.1.1—Sections with Discretely Braced Compression Flanges

At the strength limit state, the following requirement shall be satisfied:

$$M_u + \frac{1}{3} f_\ell S_{xc} \leq \phi_f M_{nc} \quad (\text{A6.1.1-1})$$

where:

- ϕ_f = resistance factor for flexure specified in Article 6.5.4.2
- f_ℓ = flange lateral bending stress determined as specified in Article 6.10.1.6 (ksi)
- M_{nc} = nominal flexural resistance based on the compression flange determined as specified in Article A6.3 (kip-in.)
- M_u = bending moment about the major-axis of the cross-section determined as specified in Article 6.10.1.6 (kip-in.)
- M_{yc} = yield moment with respect to the compression flange determined as specified in Article D6.2 (kip-in.)
- S_{xc} = elastic section modulus about the major axis of the section to the compression flange taken as M_{yc}/F_{yc} (in.³)

Eq. A6.1-2 is specified to guard against extremely monosymmetric noncomposite I-sections, in which analytical studies indicate a significant loss in the influence of the St. Venant torsional rigidity GJ on the lateral-torsional buckling resistance due to cross-section distortion. The influence of web distortion on the lateral torsional buckling resistance is larger for such members. If the flanges are of equal thickness, this limit is equivalent to $b_{fc} \geq 0.67b_{ft}$.

CA6.1.1

Eq. A6.1.1-1 addresses the effect of combined major-axis bending and compression flange lateral bending using an interaction equation approach. This equation expresses the flexural resistance in terms of the section major-axis bending moment, M_u , and the flange lateral bending stress, f_ℓ , computed from an elastic analysis, applicable within the limits on f_ℓ specified in Article 6.10.1.6 (White and Grubb, 2005).

For adequately braced sections with a compact web and compression flange, Eqs. A6.1.1-1 and A6.1.2-1 are generally a conservative representation of the resistance obtained by procedures that address the effect of flange wind moments given in Article 6.10.3.5.1 of AASHTO (2004). In the theoretical limit that the web area becomes negligible relative to the flange area, these equations closely approximate the results of an elastic-plastic section analysis in which a fraction of the width from the tips of the flanges is deducted to accommodate the flange lateral bending. The conservatism of these equations relative to the theoretical solution increases with increasing $D_{cp}t_w/b_{fc}t_{fc}$, f_ℓ , and/or $|D_{cp} - D_c|$. The conservatism at the limit on f_ℓ specified by Eq. 6.10.1.6-1 ranges from about three to ten percent for practical flexural I-sections.

The multiplication of f_ℓ by S_{xc} in Eq. A6.1.1-1 and by S_{xt} in Eq. A6.1.2-1 stems from the derivation of these equations, and is explained further in White and Grubb (2005). These equations may be expressed in a stress format by dividing both sides by the corresponding elastic section modulus, in which case, Eq. A6.1.1-1 reduces effectively to Eqs. 6.10.3.2.1-2 and 6.10.8.1.1-1 in the limit that the web approaches its noncompact slenderness limit. Correspondingly, Eq. A6.1.2-1 reduces effectively to Eqs. 6.10.7.2.1-2 and 6.10.8.1.2-1 in this limit.

The elastic section moduli, S_{xc} in this Article and S_{xt} in Article A6.1.2, are defined as M_{yc}/F_{yc} and M_{yt}/F_{yt} , respectively, where M_{yc} and M_{yt} are calculated as specified in Article D6.2. This definition is necessary so that for a composite section with a web proportioned precisely at the noncompact limit given by Eq. A6.1-1, the flexural resistance predicted by Appendix A6 is approximately the same as that predicted by Article 6.10.8. Differences between these predictions are due to the simplifying assumptions of $J = 0$ versus $J \neq 0$ in determining the elastic lateral torsional buckling resistance and the limiting

unbraced length L_r , the use of $k_c = 0.35$ versus the use of k_c from Eq. A6.3.2-6 in determining the limiting slenderness for a noncompact flange, and the use of a slightly different definition for F_{yp} . The maximum potential flexural resistance, shown as F_{max} in Figure C6.10.8.2.1-1, is defined in terms of the flange stresses as $R_h F_{yf}$ for a section with a web proportioned precisely at the noncompact web limit and designed according to the provisions of Article 6.10.8, where R_h is the hybrid factor defined in Article 6.10.1.10.1. As discussed in Article 6.10.1.1a, for composite sections, the elastically computed flange stress to be compared to this limit is to be taken as the sum of the stresses caused by the loads applied separately to the steel, short-term composite and long-term composite sections. The resulting provisions of Article 6.10.8 are a reasonable strength prediction for slender-web sections in which the web is proportioned precisely at the noncompact limit. By calculating S_{xc} and S_{xt} in the stated manner, elastic section moduli are obtained that, when multiplied by the corresponding flexural resistances predicted from Article 6.10.8 for the case of a composite slender-web section proportioned precisely at the noncompact web limit, produce approximately the same flexural resistances as predicted in Appendix A6.

For composite sections with web slenderness values that approach the compact web limit of Eq. A6.2.1-2, the effects of the loadings being applied to the different steel, short-term and long-term sections are nullified by the yielding within the section associated with the development of the stated flexural resistance. Therefore, for compact web sections, these Specifications define the maximum potential flexural resistance, shown as M_{max} in Figure C6.10.8.2.1-1, as the plastic moment M_p , which is independent of the effects of the different loadings.

A6.1.2—Sections with Discretely Braced Tension Flanges

At the strength limit state, the following requirement shall be satisfied:

$$M_u + \frac{1}{3} f_c S_{xt} \leq \phi_f M_{nt} \quad (\text{A6.1.2-1})$$

where:

- M_{nt} = nominal flexural resistance based on tension yielding determined as specified in Article A6.4 (kip-in.)
- M_{yt} = yield moment with respect to the tension flange determined as specified in Article D6.2 (kip-in.)
- S_{xt} = elastic section modulus about the major axis of the section to the tension flange taken as M_{yt}/F_{yt} (in.³)

CA6.1.2

Eq. A6.1.2-1 parallels Eq. A6.1.1-1 for discretely braced compression flanges, but applies to the case of discretely braced flanges in flexural tension due to the major-axis bending moment.

When f_t is equal to zero and M_{yc} is less than or equal to M_{yt} , the flexural resistance based on the tension flange does not control and Eq. A6.1.2-1 need not be checked. The web plastification factor for tension flange yielding, R_{pb} , from Article A6.2 also need not be computed for this case.

A6.1.3 Sections with Continuously Braced Compression Flanges

At the strength limit state, the following requirement shall be satisfied:

$$M_u \leq \phi_f R_{pc} M_{yc} \quad (\text{A6.1.3-1})$$

where:

M_{yc} = yield moment with respect to the compression flange determined as specified in Article D6.2 (kip-in.)

R_{pc} = web plastification factor for the compression flange determined as specified in Article A6.2.1 or Article A6.2.2, as applicable

A6.1.4 Sections with Continuously Braced Tension Flanges

At the strength limit state, the following requirement shall be satisfied:

$$M_u \leq \phi_f R_{pt} M_{yt} \quad (\text{A6.1.4-1})$$

where:

M_{yt} = yield moment with respect to the tension flange determined as specified in Article D6.2 (kip-in.)

R_{pt} = web plastification factor for the tension flange determined as specified in Article A6.2.1 or Article A6.2.2, as applicable

A6.2—WEB PLASTIFICATION FACTORS

A6.2.1—Compact Web Sections

Sections that satisfy the following requirement shall qualify as compact web sections:

$$\frac{2D_{cp}}{t_w} \leq \lambda_{pw(D_{cp})} \quad (\text{A6.2.1-1})$$

in which:

$\lambda_{pw(D_{cp})}$ = limiting slenderness ratio for a compact web corresponding to $2D_{cp}/t_w$

$$= \frac{\sqrt{\frac{E}{F_{yc}}}}{\left(0.54 \frac{M_p}{R_h M_y} - 0.09\right)^2} \leq \lambda_{rw} \left(\frac{D_{cp}}{D_c}\right) \quad (\text{A6.2.1-2})$$

CA6.1.3

Flange lateral bending need not be considered in continuously braced flanges, as discussed further in Article C6.10.1.6.

CA6.2.1

Eq. A6.2.1-1 ensures that the section is able to develop the full plastic moment capacity M_p provided that other flange slenderness and lateral torsional bracing requirements are satisfied. This limit is significantly less than the noncompact web limit shown in Table C6.10.1.10.2-2. It is generally satisfied by rolled I-shapes, but typically not by the most efficient built-up sections.

Eq. A6.2.1-2 is a modified web compactness limit relative to prior Specifications that accounts for the higher demands on the web in noncomposite monosymmetric I-sections and in composite I-sections in negative bending with larger shape factors, M_p/M_y (White and Barth, 1998; Barth et al., 2005). This updated web compactness limit eliminates the need for providing an interaction equation between the web and flange compactness requirements (AASHTO, 1996, 2004). Eq. A6.2.1-2 reduces to the previous web compactness limit given by Equation 6.10.4.1.2-1 in

λ_{rw} = limiting slenderness ratio for a noncompact web

$$= 5.7 \sqrt{\frac{E}{F_{yc}}} \quad (\text{A6.2.1-3})$$

where:

D_c = depth of the web in compression in the elastic range (in.). For composite sections, D_c shall be determined as specified in Article D6.3.1.

D_{cp} = depth of the web in compression at the plastic moment determined as specified in Article D6.3.2 (in.)

M_y = yield moment taken as the smaller of M_{yc} and M_{yt} determined as specified in Article D6.2 (kip-in.)

R_h = hybrid factor determined as specified in Article 6.10.1.10.1

The web plastification factors shall be taken as:

$$R_{pc} = \frac{M_p}{M_{yc}} \quad (\text{A6.2.1-4})$$

$$R_{pt} = \frac{M_p}{M_{yt}} \quad (\text{A6.2.1-5})$$

where:

M_p = plastic moment determined as specified in Article D6.1 (kip-in.)

M_{yc} = yield moment with respect to the compression flange determined as specified in Article D6.2 (kip-in.)

M_{yt} = yield moment with respect to the tension flange determined as specified in Article D6.2 (kip-in.)

R_{pc} = web plastification factor for the compression flange

R_{pt} = web plastification factor for tension flange yielding

AASHTO (2004) when $M_p/M_y = 1.12$, which is representative of the shape factor for doubly-symmetric noncomposite I-sections. The previous web compactness limit is retained in Eq. 6.10.6.2.2-1 for composite sections in positive flexure since research does not exist to quantify the web compactness requirements for these types of sections with any greater precision, and also since most composite sections in positive flexure easily satisfy this requirement.

The compactness restrictions on the web imposed by Eq. A6.2.1-2 are approximately the same as the requirements implicitly required for development of the plastic moment resistance, M_p , by the Q formula in AASHTO (2004). Both of these requirements are plotted as a function of M_p/M_y for $F_{yc} = 50.0$ ksi in Figure CA6.2.1-1.

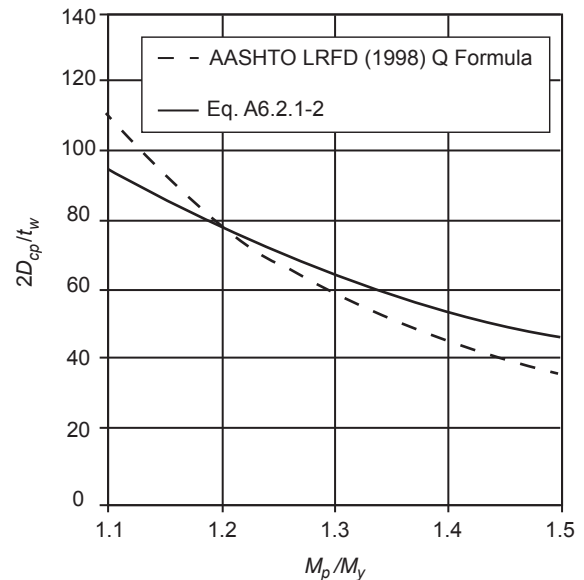

Figure CA6.2.1-1—Web Compactness Limits as a Function of M_p/M_y from the AASHTO (2004) Q formula and from Eq. A6.2.1-2 for $F_{yc} = 50.0$ ksi

For a compact web section, the maximum potential moment resistance, represented by M_{max} in Figure C6.10.8.2.1-1, is simply equal to M_p . Eqs. A6.2.1-4 and A6.2.1-5 capture this attribute and eliminate the need to repeat the subsequent flexural resistance equations in a nearly identical fashion for compact and noncompact web sections. For a compact web section, the web plastification factors are equivalent to the cross-section shape factors.

CA6.2.2

Eqs. A6.2.2-4 and A6.2.2-5 account for the influence of the web slenderness on the maximum potential flexural resistance, M_{max} in Figure C6.10.8.2.1-1, for noncompact web sections. As $2D_c/t_w$ approaches the noncompact web limit λ_{rw} , R_{pc} and R_{pt} approach values equal to R_h and the

A6.2.2—Noncompact Web Sections

Sections that do not satisfy the requirement of Eq. A6.2.1-1, but for which the web slenderness satisfies the following requirement:

$$\lambda_w < \lambda_{rw} \quad (\text{A6.2.2-1})$$

shall qualify as noncompact web sections, where:

$$\begin{aligned}\lambda_w &= \text{slenderness ratio for the web based on the elastic moment} \\ &= \frac{2D_c}{t_w} \quad (\text{A6.2.2-2})\end{aligned}$$

$$\begin{aligned}\lambda_{rw} &= \text{limiting slenderness ratio for a noncompact web} \\ &= 5.7 \sqrt{\frac{E}{F_{yc}}} \quad (\text{A6.2.2-3})\end{aligned}$$

D_c = depth of the web in compression in the elastic range (in.). For composite sections, D_c shall be determined as specified in Article D6.3.1.

The web plastification factors shall be taken as:

$$R_{pc} = \left[1 - \left(1 - \frac{R_h M_{yc}}{M_p} \right) \left(\frac{\lambda_w - \lambda_{pw(D_c)}}{\lambda_{rw} - \lambda_{pw(D_c)}} \right) \right] \frac{M_p}{M_{yc}} \leq \frac{M_p}{M_{yc}} \quad (\text{A6.2.2-4})$$

$$R_{pt} = \left[1 - \left(1 - \frac{R_h M_{yt}}{M_p} \right) \left(\frac{\lambda_w - \lambda_{pw(D_c)}}{\lambda_{rw} - \lambda_{pw(D_c)}} \right) \right] \frac{M_p}{M_{yt}} \leq \frac{M_p}{M_{yt}} \quad (\text{A6.2.2-5})$$

where:

$$\begin{aligned}\lambda_{pw(D_c)} &= \text{limiting slenderness ratio for a compact web corresponding to } 2D_c/t_w \\ &= \lambda_{pw(D_{cp})} \left(\frac{D_c}{D_{cp}} \right) \leq \lambda_{rw} \quad (\text{A6.2.2-6})\end{aligned}$$

maximum potential flexural resistance expressed within the subsequent limit state equations approaches a limiting value of $R_h M_y$. As $2D_{cp}/t_w$ approaches the compact web limit $\lambda_{pw(D_{cp})}$, Eqs. A6.2.2-4 and A6.2.2-5 define a smooth transition in the maximum potential flexural resistance, expressed by the subsequent limit state equations, from M_y to the plastic moment resistance M_p . For a compact web section, the web plastification factors R_{pc} and R_{pt} are simply the section shape factors corresponding to the compression and tension flanges, M_p/M_{yc} and M_p/M_{yt} . The subsequent flexural resistance equations are written using R_{pc} and R_{pt} for these types of sections rather than expressing the maximum resistance simply as M_p to avoid repetition of strength equations that are otherwise identical.

In Eqs. A6.2.2-4 and A6.2.2-5, explicit maximum limits of M_p/M_{yc} and M_p/M_{yt} are placed on R_{pc} and R_{pt} , respectively. As a result, the larger of the base resistances, $R_{pc}M_{yc}$ or $R_{pt}M_{yt}$, is limited to M_p for a highly monosymmetric section in which M_{yc} or M_{yt} can be greater than M_p . The limits on I_{yc}/I_{yt} given in Article 6.10.2.2 will tend to prevent the use of extremely monosymmetric sections that have M_{yc} or M_{yt} values greater than M_p . The upper limits on R_{pc} and R_{pt} have been provided to make Eqs. A6.2.2-4 and A6.2.2-5 theoretically correct in these extreme cases, even though the types of monosymmetric sections where these limits control will not likely occur.

Eq. A6.2.2-6 converts the web compactness limit given by Eq. A6.2.1-2, which is defined in terms of D_{cp} , to a value that can be used consistently in terms of D_c in Eqs. A6.2.2-4 and A6.2.2-5. In cases where $D_c/D > 0.5$, D_{cp}/D is typically larger than D_c/D ; therefore, $\lambda_{pw(D_c)}$ is smaller than $\lambda_{pw(D_{cp})}$. However, when $D_c/D < 0.5$, D_{cp}/D is typically smaller than D_c/D and $\lambda_{pw(D_c)}$ is larger than $\lambda_{pw(D_{cp})}$. In extreme cases where D_c/D is significantly less than 0.5, the web slenderness associated with the elastic cross-section, $2D_c/t_w$, can be larger than λ_{rw} while that associated with the plastic cross-section, $2D_{cp}/t_w$, can be smaller than $\lambda_{pw(D_{cp})}$ without the upper limit of $\lambda_{rw}(D_{cp}/D_c)$ that is placed on this value. That is, the elastic web is classified as slender while the plastic web is classified as compact. In these cases, the compact web limit is defined as $\lambda_{pw(D_{cp})} = \lambda_{rw}(D_{cp}/D_c)$. This is a conservative approximation aimed at protecting against the occurrence of bend-buckling in the web prior to reaching the section plastic resistance.

The ratio D_c/D is generally greater than 0.5 for noncomposite sections with a smaller flange in compression, such as typical composite I-girders in positive bending before they are made composite.

A6.3—FLEXURAL RESISTANCE BASED ON THE COMPRESSION FLANGE

A6.3.1—General

Eq. A6.1.1-1 shall be satisfied for both local buckling and lateral torsional buckling using the appropriate value of M_{nc} determined for each case as specified in Articles A6.3.2 and A6.3.3, respectively.

CA6.3.1

All of the I-section compression-flange flexural resistance equations of these Specifications are based consistently on the logic of identifying the two anchor points shown in Figure C6.10.8.2.1-1 for the case of uniform major-axis bending. Anchor point 1 is located at the length $L_b = L_p$ for lateral torsional buckling (LTB) or the flange slenderness $b_{fc}/2t_{fc} = \lambda_{pf}$ for flange local buckling (FLB) corresponding to development of the maximum potential flexural resistance, labeled as F_{max} or M_{max} in the figure, as applicable. Anchor point 2 is located at the length L_r or flange slenderness λ_{rf} for which the inelastic and elastic LTB or FLB resistances are the same.

In Article A6.3, this resistance is taken as $R_b F_{yr} S_{xc}$, where F_{yr} is taken as the smaller of $0.7F_{yc}$, F_{yw} , or $R_h F_{yr} S_{xt}/S_{xc}$, but not smaller than $0.5F_{yc}$. The first two of these resistances are the same as in Article 6.10.8. The third resistance expression, $R_h F_{yr} S_{xt}/S_{xc}$, which is simply the elastic compression-flange stress at the cross-section moment $R_h F_{yr} S_{xt} = R_h M_{yt}$, is specific to Article A6.3 and captures the effects of significant early tension-flange yielding in sections with a small depth of web in compression. In sections that have this characteristic, the early tension-flange yielding invalidates the elastic lateral torsional buckling equation on which the noncompact bracing limit L_r is based, and also makes the corresponding elastic flange local buckling equation suspect due to potential significant inelastic redistribution of stresses to the compression flange. The limit $R_h F_{yr} S_{xt}/S_{xc}$ rarely controls for bridge I-girders, but it may control in some instances of pier negative moment sections in composite continuous spans, prior to the section becoming composite, in which the top flange is significantly smaller than the bottom flange. For $L_b > L_r$ or $b_{fc}/2t_{fc} > \lambda_{rf}$, the LTB and FLB resistances are governed by elastic buckling. However, the elastic FLB resistance equations are not specified explicitly in these provisions since the limits of Article 6.10.2.2 preclude elastic FLB for specified minimum yield strengths up to and including $F_{yc} = 70.0$ ksi, which is the limiting yield strength for the application of the provisions of Appendix A6.

For unbraced lengths subjected to moment gradient, the LTB resistances for the case of uniform major-axis bending are simply scaled by the moment gradient modifier C_b , with the exception that the LTB resistance is capped at F_{max} or M_{max} , as illustrated by the dashed line in Figure C6.10.8.2.1-1. The maximum unbraced length at which the LTB resistance is equal to F_{max} or M_{max} under a moment gradient may be determined from Article D6.4.1 or D6.4.2, as applicable. The FLB resistance for moment gradient cases is the same as that for the case of uniform major-axis bending, neglecting the relatively minor influence of moment gradient effects.

A6.3.2—Local Buckling Resistance

The flexural resistance based on compression flange local buckling shall be taken as:

- If $\lambda_f \leq \lambda_{pf}$, then:

$$M_{nc} = R_{pc} M_{yc} \quad (\text{A6.3.2-1})$$

- Otherwise:

$$M_{nc} = \left[1 - \left(1 - \frac{F_{yr} S_{xc}}{R_{pc} M_{yc}} \right) \left(\frac{\lambda_f - \lambda_{pf}}{\lambda_{rf} - \lambda_{pf}} \right) \right] R_{pc} M_{yc} \quad (\text{A6.3.2-2})$$

in which:

$$\begin{aligned} \lambda_f &= \text{slenderness ratio for the compression flange} \\ &= \frac{b_{fc}}{2t_{fc}} \end{aligned} \quad (\text{A6.3.2-3})$$

$$\begin{aligned} \lambda_{pf} &= \text{limiting slenderness ratio for a compact flange} \\ &= 0.38 \sqrt{\frac{E}{F_{yc}}} \end{aligned} \quad (\text{A6.3.2-4})$$

$$\begin{aligned} \lambda_{rf} &= \text{limiting slenderness ratio for a noncompact flange} \\ &= 0.95 \sqrt{\frac{E k_c}{F_{yr}}} \end{aligned} \quad (\text{A6.3.2-5})$$

k_c = flange local buckling coefficient

- For built-up sections:

$$k_c = \frac{4}{\sqrt{\frac{D}{t_w}}} \quad (\text{A6.3.2-6})$$

$$0.35 \leq k_c \leq 0.76$$

- For rolled shapes:

$$k_c = 0.76$$

where:

F_{yr} = compression-flange stress at the onset of nominal yielding within the cross-section, including residual stress effects, but not including compression-flange lateral bending, taken as the smaller of $0.7F_{yc}$, $R_h F_{yt}$, S_{xt}/S_{xc} and F_{yw} , but not less than $0.5F_{yc}$

CA6.3.2

Eq. A6.3.2-4 defines the slenderness limit for a compact flange, whereas Eq. A6.3.2-5 gives the slenderness limit for a noncompact flange. The nominal flexural resistance of a section with a compact flange is independent of the flange slenderness, whereas the flexural resistance of a section with a noncompact flange is expressed as a linear function of the flange slenderness as illustrated in Figure C6.10.8.2.1-1. The compact flange slenderness limit is the same as specified in AISC (2005), AASHTO (1996, 2004), and Article 6.10.8.2.2. For different grades of steel, this slenderness limit is specified in Table C6.10.8.2.2-1. All current ASTM W shapes except W21×48, W14×99, W14×90, W12×65, W10×12, W8×31, W8×10, W6×15, W6×9 and W6×8.5 have compact flanges at $F_y < 50.0$ ksi.

Eq. A6.3.2-6 for the flange local buckling coefficient comes from the implementation of Johnson's (1985) research in AISC (2005). The value $k_c = 0.35$ is a lower bound to values back-calculated by equating the resistances from these provisions, or those of Article 6.10.8.2.2 where this Article is not applicable, to the measured resistances from Johnson's and other tests such as those conducted by Basler et al. (1960). Tests ranging from $D/t_w = 72$ to 245 were considered. One of the tests from Basler et al. (1960) with $D/t_w = 185$, in which the compression flange was damaged in a previous test and then subsequently straightened and cut-back to a narrower width prior to retesting, exhibited a back-calculated k_c of 0.28. This test was not considered in selecting the lower bound. Other tests by Johnson (1985) that had higher D/t_w values exhibited back-calculated k_c values greater than 0.4. A value of $k_c = 0.43$ is obtained for ideally simply-supported boundary conditions at the web-flange juncture (Timoshenko and Gere, 1961). Smaller values of k_c correspond to the fact that web local buckling in more slender webs tends to destabilize the compression flange. The value of $k_c = 0.76$ for rolled shapes is taken from AISC (2005).

- M_{yc} = yield moment with respect to the compression flange determined as specified in Article D6.2 (kip-in.)
- M_{yt} = yield moment with respect to the tension flange determined as specified in Article D6.2 (kip-in.)
- R_h = hybrid factor determined as specified in Article 6.10.1.10.1
- R_{pc} = web plastification factor for the compression flange determined as specified in Article A6.2.1 or Article A6.2.2, as applicable
- S_{xc} = elastic section modulus about the major axis of the section to the compression flange taken as M_{yc}/F_{yc} (in.³)
- S_{xt} = elastic section modulus about the major axis of the section to the tension flange taken as M_{yt}/F_{yt} (in.³)

A6.3.3—Lateral Torsional Buckling Resistance

For unbraced lengths in which the member is prismatic, the flexural resistance based on lateral torsional buckling shall be taken as:

- If $L_b \leq L_p$, then:

$$M_{nc} = R_{pc} M_{yc} \quad (\text{A6.3.3-1})$$

- If $L_p < L_b \leq L_r$, then:

$$M_{nc} = C_b \left[1 - \left(1 - \frac{F_{yr} S_{xc}}{R_{pc} M_{yc}} \right) \left(\frac{L_b - L_p}{L_r - L_p} \right) \right] R_{pc} M_{yc} \leq R_{pc} M_{yc} \quad (\text{A6.3.3-2})$$

- If $L_b > L_r$, then:

$$M_{nc} = F_{cr} S_{xc} \leq R_{pc} M_{yc} \quad (\text{A6.3.3-3})$$

in which:

- L_b = unbraced length (in.)
- L_p = limiting unbraced length to achieve the nominal flexural resistance $R_{pc} M_{yc}$ under uniform bending (in.)

$$= 1.0 r_t \sqrt{\frac{E}{F_{yc}}} \quad (\text{A6.3.3-4})$$

- L_r = limiting unbraced length to achieve the nominal onset of yielding in either flange under uniform bending with consideration of compression-flange residual stress effects (in.)

CA6.3.3

Eq. A6.3.3-4 defines the compact unbraced length limit for a member subjected to uniform major-axis bending, whereas Eq. A6.3.3-5 gives the corresponding noncompact unbraced length limit. The nominal flexural resistance of a member braced at or below the compact limit is independent of the unbraced length, whereas the flexural resistance of a member braced at or below the noncompact limit is expressed as a linear function of the unbraced length as illustrated in Figure C6.10.8.2.1-1. The compact bracing limit of Eq. A6.3.3-4 is similar to the bracing requirement for use of the general compact-section flexural resistance equations and/or the Q formula equations in AASHTO (2004). The limit given by Eq. A6.3.3-4 is generally somewhat more restrictive than the limit given by the corresponding L_p equation in AASHTO (2004) and AISC (2005). The limit given by Eq. A6.3.3-4 is based on linear regression analysis within the region corresponding to the inelastic lateral torsional buckling equation, shown qualitatively in Figure C6.10.8.2.1-1, for a wide range of data from experimental flexural tests involving uniform major-axis bending and in which the physical effective length for lateral torsional buckling is effectively 1.0.

Note that the most economical solution is not necessarily achieved by limiting the unbraced length to L_p in order to reach the maximum flexural resistance, M_{max} , particularly if the moment gradient modifier, C_b , is taken equal to 1.0.

Eq. A6.3.3-8 gives the exact beam-theory based solution for the elastic lateral torsional buckling of a doubly-symmetric I-section (Timoshenko and Gere, 1961) for the case of uniform major-axis bending when C_b is equal to 1.0 and when r_t is defined as specified by Eq. C6.10.8.2.3-1. Eq. A6.3.3-10 is a simplification of this r_t equation obtained by assuming $D = h = d$. For sections with thick flanges, Eq. A6.3.3-10 gives an r_t value that can be as much as three to four percent conservative relative to the exact equation. Use of Eq. C6.10.8.2.3-1 is permitted for software calculations or if the Engineer requires a more precise

$$= 1.95 r_t \frac{E}{F_{yr}} \sqrt{\frac{J}{S_{xc} h}} \sqrt{1 + \sqrt{1 + 6.76 \left(\frac{F_{yr} S_{xc} h}{E J} \right)^2}} \quad (\text{A6.3.3-5})$$

C_b = moment gradient modifier. In lieu of an alternative rational analysis, C_b may be calculated as follows:

- For unbraced cantilevers and for members where $M_{mid}/M_2 > 1$ or $M_2 = 0$

$$C_b = 1.0 \quad (\text{A6.3.3-6})$$

- For all other cases,

$$C_b = 1.75 - 1.05 \left(\frac{M_1}{M_2} \right) + 0.3 \left(\frac{M_1}{M_2} \right)^2 \leq 2.3 \quad (\text{A6.3.3-7})$$

F_{cr} = elastic lateral torsional buckling stress (ksi)

$$= \frac{C_b \pi^2 E}{(L_b/r_t)^2} \sqrt{1 + 0.078 \frac{J}{S_{xc} h} (L_b/r_t)^2} \quad (\text{A6.3.3-8})$$

J = St. Venant torsional constant (in.⁴)

$$= \frac{Dt_w^3}{3} + \frac{b_{fc} t_{fc}^3}{3} \left(1 - 0.63 \frac{t_{fc}}{b_{fc}} \right) + \frac{b_{ft} t_{ft}^3}{3} \left(1 - 0.63 \frac{t_{ft}}{b_{ft}} \right) \quad (\text{A6.3.3-9})$$

r_t = effective radius of gyration for lateral torsional buckling (in.)

$$= \frac{b_{fc}}{\sqrt{12 \left(1 + \frac{1}{3} \frac{D_c t_w}{b_{fc} t_{fc}} \right)}} \quad (\text{A6.3.3-10})$$

where:

F_{yr} = compression-flange stress at the onset of nominal yielding within the cross-section, including residual stress effects, but not including compression-flange lateral bending, taken as the smaller of $0.7F_{yc}$, $R_h F_{yt} S_{xt}/S_{xc}$ and F_{yw} , but not less than $0.5F_{yc}$

D_c = depth of the web in compression in the elastic range (in.). For composite sections, D_c shall be determined as specified in Article D6.3.1.

h = depth between the centerline of the flanges (in.)

M_{mid} = major-axis bending moment at the middle of the unbraced length, calculated from the moment

calculation of the elastic LTB resistance. The format of Eq. A6.3.3-8 and the corresponding L_r limit of Eq. A6.3.3-5 are particularly convenient for design usage since the terms L_b , r_t , J , S_{xc} and h are familiar and are easily calculated or can be readily obtained from design tables. Also, by simply setting J to zero, Eq. A6.3.3-8 reduces to the elastic lateral torsional buckling resistance used in Article 6.10.8.2.3.

Eq. A6.3.3-8 also gives an accurate approximation of the exact beam-theory based solution for elastic lateral torsional buckling of monosymmetric I-section members (White and Jung, 2003). For the case of $J > 0$ and uniform bending, and considering I-sections with $D/b_f > 2$, $b_{fc}/2t_{fc} > 5$ and $L_b = L_r$, the error in Eq. A6.3.3-8 relative to the exact beam-theory solution ranges from 12 percent conservative to two percent unconservative (White and Jung, 2003). A comparable I_{yc} -based equation in AASHTO (2004) gives maximum unconservative errors of approximately 14 percent for the same set of parameters studied. For the unusual case of a noncomposite compact or noncompact web section with $I_{yc}/I_{yt} > 1.5$ and $D/b_{fc} < 2$, $D/b_{ft} < 2$ or $b_{ft}/t_{ft} < 10$, consideration should be given to using the exact beam-theory equations (White and Jung, 2003) in order to obtain a more accurate solution, or else J from Eq. A6.3.3-9 may be factored by 0.8 to account for the tendency of Eq. A6.3.3-8 to overestimate the lateral torsional buckling resistance in such cases. For highly monosymmetric I-sections with a smaller compression flange or for composite I-sections in negative flexure, both Eq. A6.3.3-8 and the prior I_{yc} -based equation in AASHTO (2004) are somewhat conservative compared to rigorous beam-theory based solutions. This is due to the fact that these equations do not account for the restraint against lateral buckling of the compression flange provided by the larger tension flange or the deck. However, the distortional flexibility of the web significantly reduces this beneficial effect in many practical situations.

Eq. A6.3.3-9 is taken from El Darwish and Johnston (1965) and provides an accurate approximation of the St. Venant torsional constant, J , neglecting the effect of the web-to-flange fillets. For a compression or tension flange with a ratio, $b_f/2t_f$, greater than 7.5, the term in parentheses given in Eq. A6.3.3-9 for that flange may be taken equal to one. Equations from El Darwish and Johnston (1965) that are employed in the calculation of AISC (2005) manual values for J and include the effect of the web-to-flange fillets are included in Seaburg and Carter (1997).

The Engineer should note the importance of the web term $D_c t_w$ within Eq. A6.3.3-10. Prior Specifications have often used the radius of gyration of only the compression flange, $r_{yc} = b_{fc}/\sqrt{12}$, within design equations for LTB. This approximation can lead to significant unconservative predictions relative to experimental and refined finite-element results. The web term in Eq. A6.3.3-10 accounts for the destabilizing effects of the flexural compression within the web.

envelope value that produces the largest compression at this point in the flange under consideration, or the smallest tension if this point is never in compression (kip-in.). M_{mid} shall be due to the factored loads and shall be taken as positive when it causes compression and negative when it causes tension in the flange under consideration.

M_0 = moment at the brace point opposite to the one corresponding to M_2 , calculated from the moment envelope value that produces the largest compression at this point in the flange under consideration, or the smallest tension if this point is never in compression (kip-in.). M_0 shall be due to the factored loads and shall be taken as positive when it causes compression and negative when it causes tension in the flange under consideration.

M_1 = moment at the brace point opposite to the one corresponding to M_2 , calculated as the intercept of the most critical assumed linear moment variation passing through M_2 and either M_{mid} or M_0 , whichever produces the smaller value of C_b (kip-in.). M_1 may be calculated as follows:

- When the variation in the moment along the entire length between the brace points is concave in shape:

$$M_1 = M_0 \quad (\text{A6.3.3-11})$$

- Otherwise:

$$M_1 = 2M_{mid} - M_2 \geq M_0 \quad (\text{A6.3.3-12})$$

M_2 = except as noted below, largest major-axis bending moment at either end of the unbraced length causing compression in the flange under consideration, calculated from the critical moment envelope value (kip-in.). M_2 shall be due to the factored loads and shall be taken as positive. If the moment is zero or causes tension in the flange under consideration at both ends of the unbraced length, M_2 shall be taken as zero.

M_{yc} = yield moment with respect to the compression flange determined as specified in Article D6.2 (kip-in.)

M_{yt} = yield moment with respect to the tension flange determined as specified in Article D6.2 (kip-in.)

R_h = hybrid factor determined as specified in Article 6.10.1.10.1

R_{pc} = web plastification factor for the compression flange determined as specified in Article A6.2.1 or Article A6.2.2, as applicable

S_{xc} = elastic section modulus about the major axis of the section to the compression flange taken as M_{yc}/F_{yc} (in.³)

S_{xt} = elastic section modulus about the major axis of the section to the tension flange taken as M_{yt}/F_{yt} (in.³)

The effect of the variation in the moment along the length between brace points is accounted for by using the moment gradient modifier, C_b . Article C6.10.8.2.3 discusses the C_b parameter in detail. Article 6.10.8.2.3 addresses unbraced lengths in which the member is nonprismatic. Article A6.3.3 extends the provisions for such unbraced lengths to members with compact and noncompact webs.

Where C_b is greater than 1.0, indicating the presence of a moment gradient, the lateral torsional buckling resistances may alternatively be calculated by the equivalent procedures specified in Article D6.4.2. Both the equations in this Article and in Article D6.4.2 permit M_{max} in Figure C6.10.8.2.1-1 to be reached at larger unbraced lengths when C_b is greater than 1.0. The procedures in Article D6.4.2 allow the Engineer to focus directly on the maximum unbraced length at which the flexural resistance is equal to M_{max} . The use of these equivalent procedures is strongly recommended when C_b values greater than 1.0 are utilized in the design.

For unbraced lengths where the member consists of noncomposite monosymmetric sections and is subject to reverse curvature bending, the lateral torsional buckling resistance shall be checked for both flanges, unless the top flange is considered to be continuously braced.

For unbraced lengths in which the member is nonprismatic, the flexural resistance based on lateral torsional buckling may be taken as the smallest resistance within the unbraced length under consideration determined from Eq. A6.3.3-1, A6.3.3-2, or A6.3.3-3, as applicable, assuming the unbraced length is prismatic. The flexural resistance M_{nc} at each section within the unbraced length shall be taken equal to this resistance multiplied by the ratio of S_{xc} at the section under consideration to S_{xc} at the section governing the lateral torsional buckling resistance. The moment gradient modifier, C_b , shall be taken equal to 1.0 in this case and L_b shall not be modified by an effective length factor.

For unbraced lengths containing a transition to a smaller section at a distance less than or equal to 20 percent of the unbraced length from the brace point with the smaller moment, the flexural resistance based on lateral torsional buckling may be determined assuming the transition to the smaller section does not exist, provided the lateral moment of inertia of the flange or flanges of the smaller section is equal to or larger than one-half the corresponding value in the larger section.

A6.4—FLEXURAL RESISTANCE BASED ON TENSION FLANGE YIELDING

The nominal flexural resistance based on tension flange yielding shall be taken as:

$$M_{nt} = R_{pt} M_{yt} \quad (\text{A6.4-1})$$

where:

- M_{yt} = yield moment with respect to the tension flange determined as specified in Article D6.2 (kip-in.)
- R_{pt} = web plastification factor for tension flange yielding determined as specified in Article A6.2.1 or Article A6.2.2, as applicable

CA6.4

Eq. A6.4-1 implements a linear transition in the flexural resistance between M_p and M_{yt} as a function of $2D_c/t_w$ for monosymmetric sections with a larger tension flange and for composite sections in negative flexure

where first yielding occurs in the top flange or in the longitudinal reinforcing steel. In the limit that $2D_c/t_w$ approaches the noncompact web limit given by Eq. A6.2.2-3, Eq. A6.4-1 reduces to the tension flange yielding limit specified in Article 6.10.8.3.

For sections in which $M_{yt} > M_{yc}$, Eq. A6.4-1 does not control and need not be checked.

APPENDIX B6—MOMENT REDISTRIBUTION FROM INTERIOR-PIER I-SECTIONS IN STRAIGHT CONTINUOUS-SPAN BRIDGES

B6.1—GENERAL

This Article shall apply for the calculation of redistribution moments from the interior-pier sections of continuous span I-section flexural members at the service and/or strength limit states. These provisions shall apply only for I-section members that satisfy the requirements of Article B6.2.

B6.2—SCOPE

Moment redistribution shall be applied only in straight continuous span I-section members whose bearing lines are not skewed more than 10 degrees from normal and along which there are no discontinuous cross-frames. Sections may be either composite or noncomposite in positive or negative flexure.

Cross-sections throughout the unbraced lengths immediately adjacent to interior-pier sections from which moments are redistributed shall have a specified minimum yield strength not exceeding 70.0 ksi. Holes shall not be placed within the tension flange over a distance of two times the web depth on either side of the interior-pier sections from which moments are redistributed. All other sections having tension flange holes shall satisfy the requirements of Article 6.10.1.8 after the moments are redistributed.

CB6.1

These optional provisions replace the ten-percent redistribution allowance given in previous Specifications and provide a simple more rational approach for calculating the percentage redistribution from interior-pier sections. This approach utilizes elastic moment envelopes and does not require the direct use of any inelastic analysis methods. The restrictions of Article B6.2 ensure significant ductility and robustness at the interior-pier sections.

In conventional elastic analysis and design, moment and shear envelopes are typically determined by elastic analysis with no redistribution due to the effects of yielding considered. The sections are dimensioned for a resistance equal to or greater than that required by the envelopes. Designs to meet these requirements often involve the addition of cover plates to rolled beams, which introduces details that often have low fatigue resistance, or the introduction of multiple flange transitions in welded beams, which can result in additional fabrication costs. Where appropriate, the use of these provisions to account for the redistribution of moments makes it possible to eliminate such details by using prismatic sections along the entire length of the bridge or between field splices. This practice can improve overall fatigue resistance and provide significant fabrication economies.

Development of these provisions is documented in a number of comprehensive reports (Barker et al., 1997; Schilling et al., 1997; White et al., 1997) and in a summary paper by Barth et al. (2004), which gives extensive references to other supporting research. These provisions account for the fact that the compression flange slenderness, $b_{fc}/2t_{fc}$, and the cross-section aspect ratio, D/b_{fc} , are the predominant factors that influence the moment-rotation behavior at adequately braced interior-pier sections. The provisions apply to sections with compact, noncompact or slender webs.

CB6.2

The subject procedures have been developed predominantly in the context of straight nonskewed bridge superstructures without discontinuous cross-frames. Therefore, their use is restricted to bridges that do not deviate significantly from these idealized conditions.

The development of these provisions focused on nonhybrid and hybrid girders with specified minimum yield strengths up to and including 70.0 ksi. Therefore, use of these provisions with larger yield strengths is not permitted. The influence of tension-flange holes on potential net section fracture at cross-sections experiencing significant inelastic strains is not well known. Therefore, tension flange holes are not allowed over a distance of two times the web depth, D , on either side of the interior-

Moments shall be redistributed only at interior-pier sections for which the cross-sections throughout the unbraced lengths immediately adjacent to those sections satisfy the requirements of Articles B6.2.1 through B6.2.6. If the refined method of Article B6.6 is used for calculation of the redistribution moments, all interior-pier sections are not required to satisfy these requirements; however, moments shall not be redistributed from sections that do not satisfy these requirements. Such sections instead shall satisfy the provisions of Articles 6.10.4.2, 6.10.8.1 or Article A6.1, as applicable, after redistribution. If the provisions of Articles B6.3 or B6.4 are utilized to calculate interior-pier redistribution moments, the unbraced lengths immediately adjacent to all interior-pier sections shall satisfy the requirements of Articles B6.2.1 through B6.2.6.

B6.2.1—Web Proportions

The web within the unbraced length under consideration shall be proportioned such that:

$$\frac{D}{t_w} \leq 150 \quad (\text{B6.2.1-1})$$

$$\frac{2D_c}{t_w} \leq 6.8 \sqrt{\frac{E}{F_{yc}}} \quad (\text{B6.2.1-2})$$

and:

$$D_{cp} \leq 0.75D \quad (\text{B6.2.1-3})$$

where:

D_c = depth of the web in compression in the elastic range (in.). For composite sections, D_c shall be determined as specified in Article D6.3.1.

D_{cp} = depth of the web in compression at the plastic moment determined as specified in Article D6.3.2 (in.)

B6.2.2—Compression Flange Proportions

The compression flange within the unbraced length under consideration shall be proportioned such that:

$$\frac{b_{fc}}{2t_{fc}} \leq 0.38 \sqrt{\frac{E}{F_{yc}}} \quad (\text{B6.2.2-1})$$

and:

$$b_{fc} \geq \frac{D}{4.25} \quad (\text{B6.2.2-2})$$

pier sections from which moments are redistributed. The distance $2D$ is an approximate upper bound for the length of the zone of primary inelastic response at these pier sections.

Unless a direct analysis is conducted by the Refined Method outlined in Article B6.6, all the interior-pier sections of a continuous-span member are required to satisfy the requirements of Articles B6.2.1 through B6.2.6 in order to redistribute the pier moments. This is because of the approximations involved in the simplified provisions of Articles B6.3 and B6.4 and the fact that inelastic redistribution moments from one interior support generally produce some nonzero redistribution moments at all of the interior supports.

CB6.2.1

Eq. B6.2.1-1 simply parallels Eq. 6.10.2.1.1-1 and is intended to eliminate the use of any benefits from longitudinal stiffening of the web at the pier section. The moment-rotation characteristics of sections with longitudinal web stiffeners have not been studied. Eqs. B6.2.1-2 and B6.2.1-3 are limits of the web slenderness and the depth of the web in compression considered in the development of these procedures.

CB6.2.2

The compression flange is required to satisfy the compactness limit within the unbraced lengths adjacent to the pier section. This limit is restated in Eq. B6.2.2-1. Slightly larger $b_{fc}/2t_{fc}$ values than this limit have been considered within the supporting research for these provisions. The compactness limit from Articles A6.3.2 and 6.10.8.2 is used for simplicity.

Eq. B6.2.2-2 represents the largest aspect ratio $D/b_{fc} = 4.25$ considered in the supporting research. As noted in Articles C6.10.2.2 and CB6.1, increasing values of this ratio have a negative influence on the strength and moment-rotation characteristics of I-section members.

B6.2.3—Section Transitions

The steel I-section member shall be prismatic within the unbraced length under consideration.

B6.2.4—Compression Flange Bracing

The unbraced length under consideration shall satisfy:

$$L_b \leq \left[0.1 - 0.06 \left(\frac{M_1}{M_2} \right) \right] \frac{r_t E}{F_{yc}} \quad (\text{B6.2.4-1})$$

where:

- L_b = unbraced length (in.)
 M_1 = bending moment about the major-axis of the cross-section at the brace point with the lower moment due to the factored loads, taken as either the maximum or minimum moment envelope value, whichever produces the smallest permissible unbraced length (kip-in.)
 M_2 = bending moment about the major-axis of the cross-section at the brace point with the higher moment due to the factored loads, taken as the critical moment envelope value (kip-in.)
 r_t = effective radius of gyration for lateral torsional buckling within the unbraced length under consideration determined from Eq. A6.3.3-10 (in.)

(M_1/M_2) shall be taken as negative when the moments cause reverse curvature.

B6.2.5—Shear

Webs with or without transverse stiffeners within the unbraced length under consideration shall satisfy the following requirement at the strength limit state:

$$V_u \leq \phi_v V_{cr} \quad (\text{B6.2.5-1})$$

where:

- ϕ_v = resistance factor for shear specified in Article 6.5.4.2
 V_u = shear in the web due to the factored loads (kip)
 V_{cr} = shear-buckling resistance determined from Eq. 6.10.9.2-1 for unstiffened webs and from Eq. 6.10.9.3.3-1 for stiffened webs (kip)

B6.2.6—Bearing Stiffeners

Bearing stiffeners designed by the provisions of Article 6.10.11.2 shall be placed at the interior-pier section under consideration.

CB6.2.3

Only members that are prismatic within the unbraced lengths adjacent to interior piers have been considered in the supporting research. Therefore, section transitions are prohibited in these regions.

CB6.2.4

Eq. B6.2.4-1 gives approximately the same results as the compact-section compression-flange bracing requirements in Article 6.10.4.1.7 of AASHTO (2004), but is written in terms of r_t rather than r_y . The use of r_y in the prior equation leads to an ambiguity in the application of this bracing limit to composite sections in negative flexure. Furthermore, since r_t focuses strictly on the compression region of the cross-section and does not involve the top flange or the deck for a composite section in negative flexure, it is believed to address the bracing requirements for such a section in a more correct fashion.

Since the negative moment envelope always tends to be concave in shape in the vicinity of interior-pier sections, the consideration of the moment values at the middle of the unbraced length, as required in general for the calculation of C_b in Articles 6.10.8.2.3 and A6.3.3, is not necessary. Consideration of the moment gradient effects based on the ratio of the end values, M_1/M_2 , is sufficient and conservative.

If $D_{ctw}/b_{fc}t_{fc}$ in Eq. 6.10.8.2.3-9 or A6.3.3-10 is taken as a representative value of 2.0 and F_{yc} is taken as 50 ksi, Eq. B6.2.4-1 is satisfied when $L_b < 13b_{fc}$ for $M_1/M_2 = 0$ and $L_b < 9b_{fc}$ for $M_1/M_2 = 0.5$.

CB6.2.5

Use of web shear post-buckling resistance or tension-field action is not permitted within the vicinity of the pier sections designed for redistribution of the negative bending moments.

B6.3—SERVICE LIMIT STATE

B6.3.1—General

Load combination Service II in Table 3.4.1-1 shall apply.

B6.3.2—Flexure

B6.3.2.1—Adjacent to Interior-Pier Sections

With the exception that the requirement of Eq. 6.10.4.2.2-4 shall be satisfied, the provisions of Article 6.10.4.2 shall not be checked within the regions extending in each adjacent span from interior-pier sections satisfying the requirements of Article B6.2 to the nearest flange transition or point of dead-load contraflexure, whichever is closest.

B6.3.2.2—At All Other Locations

Sections at all other locations shall satisfy the provisions of Article 6.10.4.2, as applicable, after redistribution. For composite sections in positive flexure, the redistribution moments shall be applied to the long-term composite section when computing flexural stresses in the steel section. For computing longitudinal flexural stresses in the concrete deck due to the redistribution moments, the provisions of Article 6.10.1.1.1d shall apply.

The redistribution moments shall be calculated according to the provisions specified in Article B6.3.3 and shall be added to the elastic moments due to the Service II loads.

CB6.3.2.1

In checking permanent deflections under Load Combination Service II, local yielding is permitted at interior supports satisfying the requirements of Article B6.2. This results in redistribution. The permanent deflections are controlled by imposing the appropriate flange stress limits of Article 6.10.4.2 in each adjacent span at sections outside the nearest flange transition location or point of permanent-load contraflexure, whichever is closest to the interior support under consideration, after redistribution. The appropriate redistribution moments are to be added to the elastic moments due to the Service II loads prior to making these checks. The influence of the strength and ductility at the interior-pier sections is considered within the calculation of the redistribution moments. Therefore, the flange stress limits of Article 6.10.4.2 need not be checked within the regions extending into each adjacent span from the interior-pier section under consideration to the closest point cited above. The provisions of Appendix B6 are not intended to relax the requirement of Eq. 6.10.4.2.2-4. This requirement should be satisfied based on the elastic moments before redistribution.

Additional cambering to account for the small residual deformations associated with redistribution of interior-pier section moments is not recommended. A full-scale bridge designed to permit redistribution of negative moments sustained only very small permanent deflections when tested under the overload condition (Roeder and Eltvik, 1985).

CB6.3.2.2

The redistribution moments are in effect permanent moments that remain in the structure. The corresponding locked-in redistribution stresses in composite sections tend to decrease with time as a result of creep in the concrete. However, these redistribution stresses may be continually renewed by subsequent passages of similar loadings. Therefore, the flexural stresses in the steel section due to these moments are to be conservatively calculated based on the long-term composite section.

B6.3.3—Redistribution Moments**B6.3.3.1—At Interior-Pier Sections**

At each interior-pier section where the flexural stresses are not checked as permitted in Article B6.3.2.1, the redistribution moment for the Service II loads shall be taken as:

$$M_{rd} = |M_e| - M_{pe} \quad (\text{B6.3.3.1-1})$$

in which:

$$0 \leq M_{rd} \leq 0.2|M_e| \quad (\text{B6.3.3.1-2})$$

where:

M_{pe} = negative-flexure effective plastic moment for the service limit state determined as specified in Article B6.5 (kip-in.)

M_e = critical elastic moment envelope value at the interior-pier section due to the Service II loads (kip-in.)

B6.3.3.2—At All Other Locations

The redistribution-moment diagram for the Service II load combination shall be determined by connecting with straight lines the redistribution moments at adjacent interior-pier sections. The lines shall be extended to any points of zero redistribution moment at adjacent supports, including at the abutments.

CB6.3.3.1

Eqs. B6.3.3.1-1, B6.4.2.1-1 and B6.4.2.1-2 are based on concepts from shakedown analysis of continuous-span girders under repeated application of moving loads (ASCE, 1971; Schilling et al., 1997) using an effective plastic moment that accounts for the interior-pier section moment-rotation characteristics. Shakedown is the appropriate limit state related to moment redistribution in bridges (Galambos, et al. 1993).

At the service limit state, the effective plastic moment in Eq. B6.3.3.1-1 is based on an estimated upper-bound plastic rotation of 0.009 radians at the pier sections, determined by direct inelastic analysis of various trial designs (Schilling, 1986). Flange lateral bending effects are not considered in Eq. B6.3.3.1-1 since due to the restrictions of Article B6.2, the flange lateral bending effects at the interior supports under the Service II Load Combination are taken to be negligible. The refinement of these calculations by consideration of flange lateral bending effects is considered unjustified.

Eq. B6.3.3.1-2 is intended to prevent the use of an interior-pier section that is so small that it could potentially violate the assumed upper-bound inelastic rotation of 0.009 radians under Service II conditions. Note that if the upper limit of Eq. B6.3.3.1-2 is violated, a new interior-pier section must be selected that will ensure that this limit is satisfied.

CB6.3.3.2

Figure CB6.3.3.2-1 illustrates a typical redistribution moment diagram for a three-span continuous member for which the redistribution moments are greater than zero at both interior-pier sections. After the live loads are removed, the redistribution moments are held in equilibrium by the support reactions. Therefore, the redistribution moments must vary linearly between the supports.

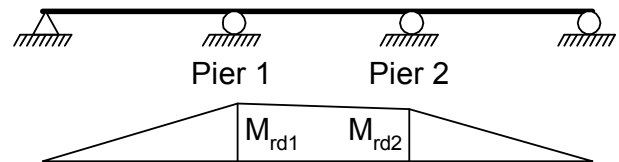

Figure CB6.3.3.2-1—Typical Redistribution Moment Diagram

B6.4—STRENGTH LIMIT STATE**B6.4.1—Flexural Resistance****B6.4.1.1—Adjacent to Interior-Pier Sections**

The flexural resistances of sections within the unbraced lengths immediately adjacent to interior-pier sections satisfying the requirements of Article B6.2 shall not be checked.

B6.4.1.2—At All Other Locations

Sections at all other locations shall satisfy the provisions of Articles 6.10.7, 6.10.8.1 or A6.1, as applicable, after redistribution. For composite sections in positive flexure, the redistribution moments shall be applied to the long-term composite section when computing flexural stresses in the steel section. For computing longitudinal flexural stresses in the concrete deck due to the redistribution moments, the provisions of Article 6.10.1.1.d shall apply.

The redistribution moments shall be calculated using the provisions of Article B6.4.2 and shall be added to the elastic moments due to the factored loads at the strength limit state.

B6.4.2—Redistribution Moments**B6.4.2.1—At Interior-Pier Sections**

At each interior-pier section where the flexural resistances are not checked as permitted in Article B6.4.1.1, the redistribution moment at the strength limit state shall be taken as the larger of:

$$M_{rd} = |M_e| + \frac{1}{3} f_t S_{xc} - \phi_f M_{pe} \quad (\text{B6.4.2.1-1})$$

or:

$$M_{rd} = |M_e| + \frac{1}{3} f_t S_{xt} - \phi_f M_{pe} \quad (\text{B6.4.2.1-2})$$

in which:

$$0 \leq M_{rd} \leq 0.2 |M_e| \quad (\text{B6.4.2.1-3})$$

where:

CB6.4.1.1

Yielding is permitted at interior supports at the strength limit state, and results in redistribution of moments. The influence of the strength and ductility at the interior-pier sections is considered within the calculation of the redistribution moments. Therefore, the flexural resistances of sections within the unbraced lengths immediately adjacent to interior-pier sections from which moments are redistributed need not be checked.

CB6.4.1.2

Regions outside of unbraced lengths immediately adjacent to interior-pier sections from which moments are redistributed are designed in the same fashion as when the procedures of this Article are not applied, with the exception that the appropriate redistribution moments are to be added to the elastic moments due to the factored loads at the strength limit state prior to making the design checks.

CB6.4.2.1

At the strength limit state, the effective plastic moment in Eqs. B6.4.2.1-1 and B6.4.2.1-2 is based on an estimated upper bound plastic rotation of 0.03 radians at the pier sections, determined by direct inelastic analysis of various trial designs (Schilling, 1986).

Flange lateral bending effects are conservatively included in Eqs. B6.4.2.1-1 and B6.4.2.1-2 to account for the reduction in the flexural resistance of the interior-pier section at the strength limit state due to these effects. The inclusion of f_t in these equations is intended primarily to address the design for wind loads. Eq. B6.4.2.1-3 is intended to prevent the use of an interior-pier section that is so small that it could potentially violate the assumed upper-bound inelastic rotation of 0.03 radians at the strength limit state. Note that if the upper limit of Eq. B6.4.2.1-3 is violated, a new interior-pier section must be selected that will ensure that this limit is satisfied.

A form of Eqs. B6.4.2.1-1 and B6.4.2.1-2 was proposed in the original research by Barker et al. (1997) that included a resistance factor for shakedown of

- f_ℓ = lateral bending stress in the flange under consideration at the interior-pier section (ksi). For continuously braced tension or compression flanges, f_ℓ shall be taken as zero.
- ϕ_f = resistance factor for flexure specified in Article 6.5.4.2
- M_{pe} = negative-flexure effective plastic moment for the strength limit state determined as specified in Article B6.5 (kip-in.)
- M_e = critical elastic moment envelope value at the interior-pier section due to the factored loads (kip-in.)
- M_{yc} = yield moment with respect to the compression flange determined as specified in Article D6.2 (kip-in.)
- M_{yt} = yield moment with respect to the tension flange determined as specified in Article D6.2 (kip-in.)
- S_{xc} = elastic section modulus about the major axis of the section to the compression flange taken as M_{yc}/F_{yc} (in.³)
- S_{xt} = elastic section modulus about the major axis of the section to the tension flange taken as M_{yt}/F_{yt} (in.³)

B6.4.2.2—At All Other Sections

The redistribution-moment diagram for the strength limit state shall be determined using the same procedure specified for the Service II load combination in Article B6.3.3.2.

B6.5—EFFECTIVE PLASTIC MOMENT

B6.5.1—Interior-Pier Sections with Enhanced Moment-Rotation Characteristics

For interior-pier sections satisfying the requirements of Article B6.2 and which contain:

- Transverse stiffeners spaced at $D/2$ or less over a minimum distance of $D/2$ on each side of the interior-pier section

or:

- Ultracompact webs that satisfy:

$$\frac{2D_{cp}}{t_w} \leq 2.3 \sqrt{\frac{E}{F_{yc}}} \quad (\text{B6.5.1-1})$$

where:

- D_{cp} = depth of the web in compression at the plastic moment determined as specified in Article D6.3.2 (in.)

the effective plastic moment shall be taken as:

$\phi_{sd} = 1.1$. The resistance factor of $\phi_{sd} = 1.1$ is justified for this limit state because the shakedown loading is generally less than the maximum plastic resistance and because progressively increasing permanent deflections give ample warning of pending failure. The resistance factor for flexure ϕ_f of Article 6.5.4.2 is selected in these provisions to account for the fact that yielding within regions of positive flexure and the corresponding redistribution of positive bending moments to the interior-pier sections is not considered. Also, as discussed in Article C6.10.7.1.2, additional requirements are specified in continuous spans where significant yielding may occur prior to reaching the section resistances of compact sections in positive flexure.

CB6.4.2.2

Figure CB6.3.3.2-1 illustrates a typical redistribution moment diagram.

CB6.5.1

Tests have shown that members with interior-pier sections that satisfy either of the requirements of this Article, in addition to the requirements of Article B6.2, exhibit enhanced moment-rotation characteristics relative to members that satisfy only the requirements of Article B6.2 (White et al., 1997; Barth et al., 2004). These additional requirements involve the use of:

- Transverse stiffeners close to the interior-pier section to help restrain the local buckling distortions of the web and compression flange within this region,

or:

- A web that is sufficiently stocky such that its distortions are reduced and the flange local buckling distortions are highly restrained, termed an ultracompact web.

For noncompact web and slender web sections, the influence of the web slenderness on the effective plastic moment is captured through the maximum flexural

- For the Service Limit State:

$$M_{pe} = M_n \quad (\text{B6.5.1-2})$$

- For the Strength Limit State:

$$M_{pe} = \left(\begin{array}{l} 2.78 - 2.3 \frac{b_{fc}}{t_{fc}} \sqrt{\frac{F_{yc}}{E}} \\ -0.35 \frac{D}{b_{fc}} + 0.39 \frac{b_{fc}}{t_{fc}} \sqrt{\frac{F_{yc}}{E}} \frac{D}{b_{fc}} \end{array} \right) M_n \leq M_n \quad (\text{B6.5.1-3})$$

where:

M_n = nominal flexural resistance of the interior-pier section taken as the smaller of $F_{nc}S_{xc}$ and $F_{nt}S_{xt}$, with F_{nc} and F_{nt} determined as specified in Article 6.10.8. For sections with compact or noncompact webs, M_n may be taken as the smaller of M_{nc} and M_{nt} determined as specified in Appendix A6 (kip-in.).

B6.5.2—All Other Interior-Pier Sections

For interior-pier sections satisfying the requirements of Article B6.2, but not satisfying the requirements of Article B6.5.1, the effective plastic moment shall be taken as:

- For the Service Limit State:

$$M_{pe} = \left(\begin{array}{l} 2.90 - 2.3 \frac{b_{fc}}{t_{fc}} \sqrt{\frac{F_{yc}}{E}} \\ -0.35 \frac{D}{b_{fc}} + 0.39 \frac{b_{fc}}{t_{fc}} \sqrt{\frac{F_{yc}}{E}} \frac{D}{b_{fc}} \end{array} \right) M_n \leq M_n \quad (\text{B6.5.2-1})$$

- For the Strength Limit State:

$$M_{pe} = \left(\begin{array}{l} 2.63 - 2.3 \frac{b_{fc}}{t_{fc}} \sqrt{\frac{F_{yc}}{E}} \\ -0.35 \frac{D}{b_{fc}} + 0.39 \frac{b_{fc}}{t_{fc}} \sqrt{\frac{F_{yc}}{E}} \frac{D}{b_{fc}} \end{array} \right) M_n \leq M_n \quad (\text{B6.5.2-2})$$

B6.6—REFINED METHOD

B6.6.1—General

Continuous span I-section flexural members satisfying the requirements of Article B6.2 also may be proportioned based on a direct analysis. In this approach, the redistribution moments shall be determined by satisfying rotational

resistance term M_n in Eqs. B6.5.1-2 and B6.5.1-3, and in Eqs. B6.5.2-1 and B6.5.2-2.

CB6.5.2

Eqs. B6.5.2-1 and B6.5.2-2 are based on a lower-bound estimate of the moment-rotation characteristics of interior-pier sections that satisfy the limits of Article B6.2 (Barth et al., 2004). Cases with unbraced lengths smaller than the limit given by Eq. B6.2.4-1, significant torsional restraint from a composite deck, and/or compression-flange slenderness values significantly smaller than the compact flange limit often exhibit significantly enhanced moment-rotation characteristics and corresponding larger effective plastic moments than the values obtained from these equations.

The web slenderness, $2D_c/t_w$ or $2D_{cp}/t_w$, does not appear directly in Eqs. B6.5.2-1 and B6.5.2-2. For noncompact and slender web sections, the influence of the web slenderness on the effective plastic moment is captured through the maximum flexural resistance term M_n .

CB6.6.1

The Engineer is also provided the option to use a refined method in which a direct shakedown analysis is conducted at the service and/or strength limit states. This analysis requires the simultaneous satisfaction of

continuity and specified inelastic moment-rotation relationships at selected interior-pier sections. Direct analysis may be employed at the service and/or strength limit states. The elastic moment envelope due to the factored loads shall be used in this analysis.

For the direct analysis, the redistribution moments shall be determined using the elastic stiffness properties of the short-term composite section assuming the concrete deck to be effective over the entire span length. For composite sections in positive flexure, the redistribution moments shall be applied to the long-term composite section when computing elastic flexural stresses in the steel section. For computing elastic longitudinal flexural stresses in the concrete deck due to the redistribution moments, the provisions of Article 6.10.1.1.d shall apply.

Sections adjacent to interior piers from which moments are redistributed shall satisfy the requirements of Article B6.3.2.1 at the service limit state and Article B6.4.1.1 at the strength limit state. All other sections shall satisfy all applicable provisions of Articles 6.10.4.2, 6.10.7, 6.10.8.1, or A6.1 after a solution is found.

In applying direct analysis at the strength limit state, the ordinates of the nominal moment-rotation curves shall be multiplied by the resistance factor for flexure specified in Article 6.5.4.2. In applying direct analysis at the Service II limit state, the nominal moment-rotation curves shall be used.

continuity and moment-rotation relationships at all interior-pier sections from which moments are redistributed. If software that handles this type of calculation along with the determination of the elastic moment envelopes does not exist, significant manual work is required in conducting the analysis calculations. The Engineer can gain some additional benefit when using direct analysis in that the restriction that all interior-pier sections within the member satisfy the requirements of Article B6.2.1 is relaxed. Also, the directly calculated inelastic rotations at the interior pier sections will tend to be smaller than the upper-bound values that the equations in Articles B6.3 through B6.5 are based upon.

The redistribution moments are to be computed using the stiffness properties of the short-term composite section because the redistribution moments are formed by short-term loads.

Although direct analysis methods can be formulated that account for the redistribution of moments from regions of positive flexure, there is typically no significant economic benefit associated with redistribution of positive bending moments. This is because, in most practical cases, the interior-pier sections have the highest elastic stresses. Also, the development of some inelastic rotations at the pier sections simply allows a continuous-span member to respond in a fashion involving only slightly less rotational restraint from the adjacent spans than if these sections remain elastic.

With the exception of the additional requirements of Article 6.10.7.1.2 for composite sections subjected to positive flexure within continuous spans in which the adjacent interior-pier sections do not satisfy Article B6.2, these Specifications generally neglect the influence of partial yielding prior to and associated with the development of member maximum flexural resistances. Therefore, the influence of partial yielding within regions of positive flexure on the redistribution of moments to the interior piers and on the calculated inelastic pier rotations is also to be neglected within the direct analysis approach. The unconservative attributes associated with neglecting positive-moment yielding prior to reaching the maximum flexural resistance within regions of positive flexure are offset by:

- The use of $\phi_f = 1.0$ rather than a shakedown resistance factor of $\phi_{sd} = 1.1$ as originally formulated by Barker et al. (1997) and discussed in Article CB6.4.2.1,

and:

- The lower-bound nature of the moment-rotation relationships utilized for the interior-pier sections.

Moment-rotation relationships have been proposed that account for yielding in positive flexure, such as in Barker et al. (1997). However, these relationships account in only a very simplistic fashion for the distributed yielding effects that

B6.6.2—Nominal Moment-Rotation Curves

At interior-pier sections that satisfy the requirements of Article B6.2, the nominal moment-rotation curve given in Figure B6.6.2-1 may be used.

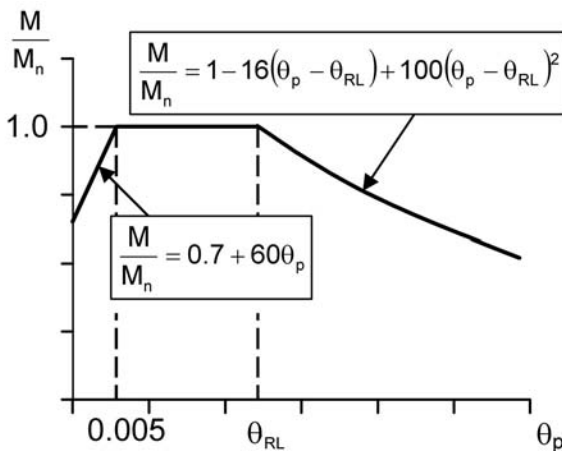

Figure B6.6.2-1—Nominal Moment-Rotation Curve for Interior-Pier Sections Satisfying Article B6.2

in which:

θ_{RL} = plastic rotation at which the interior-pier section moment nominally begins to decrease with increasing θ_p (radians)

$$= 0.137 - 0.143 \frac{b_{fc}}{t_{fc}} \sqrt{\frac{F_{yc}}{E}} - 0.0216 \frac{D}{b_{fc}} + 0.0241 \frac{D}{b_{fc}} \frac{b_{fc}}{t_{fc}} \sqrt{\frac{F_{yc}}{E}} \quad (\text{B6.6.2-1})$$

for sections that satisfy the additional requirements specified in Article B6.5.1, and:

$$= 0.128 - 0.143 \frac{b_{fc}}{t_{fc}} \sqrt{\frac{F_{yc}}{E}} - 0.0216 \frac{D}{b_{fc}} + 0.0241 \frac{D}{b_{fc}} \frac{b_{fc}}{t_{fc}} \sqrt{\frac{F_{yc}}{E}} \quad (\text{B6.6.2-2})$$

for all other sections.

where:

θ_p = plastic rotation at the interior-pier section (rad.)
 M = bending moment about the major-axis of the cross-section due to the factored loads (kip-in.)

tend to occur over a significant length due to the small moment gradients that typically exist within regions of positive flexure. Significantly greater accuracy can be achieved in the analysis for these effects by the use of distributed plasticity analysis models rather than plastic-hinge type models. However, these types of analysis models are not readily accessible to the Engineer at the present time.

CB6.6.2

The moment-rotation relationships in this Article are developed in White et al. (1997) and Barth et al. (2004). The moment-rotation relationships for interior-pier sections with enhanced moment-rotation characteristics that satisfy the additional limits of Article B6.5.1 are given by Eq. B6.6.2-1, which is obtained by replacing the coefficient 0.128 in Eq. B6.6.2-2 by 0.137 (Barth et al., 2004). It is expected that exceeding the limits of Article B6.2 may result in substantial degradation of the interior-pier moment-rotation characteristics. Therefore, the restrictions of Article B6.2 may not be relaxed by use of alternative moment-rotation relationships.

- M_n = nominal flexural resistance of the interior-pier section taken as the smaller of $F_{nc}S_{xc}$ and $F_{nt}S_{xt}$, with F_{nc} and F_{nt} determined as specified in Article 6.10.8 (kip-in.). For sections with compact or noncompact webs, M_n may be taken as the smaller of M_{nc} and M_{nt} determined as specified in Appendix A6. For load combinations that induce significant flange lateral bending stresses, the influence of flange lateral bending shall be considered by deducting the larger of $\frac{1}{3}f_\ell S_{xc}$ or $\frac{1}{3}f_\ell S_{xt}$ from the above values.
- f_ℓ = lateral bending stress in the flange under consideration at the interior-pier section (ksi). For continuously braced tension or compression flanges, f_ℓ shall be taken as zero.

Other nominal moment-rotation relationships may be employed for interior-pier sections that satisfy the requirements of Article B6.2 provided that the relationships are developed considering all potential factors that influence the moment-rotation characteristics within the restrictions of those requirements.

Interior-pier sections not satisfying the requirements of Article B6.2 shall be assumed to remain elastic in the analysis, and shall satisfy the provisions of Articles 6.10.4.2, 6.10.8.1, or Article A6.1, as applicable, after a solution is found.

APPENDIX C6—BASIC STEPS FOR STEEL BRIDGE SUPERSTRUCTURES**C6.1—GENERAL**

This outline is intended to be a generic overview of the design process. It should not be regarded as fully complete, nor should it be used as a substitute for a working knowledge of the provisions of this section.

C6.2—GENERAL CONSIDERATIONS

- A. Design Philosophy (1.3.1)
- B. Limit States (1.3.2)
- C. Design and Location Features (2.3) (2.5)

C6.3—SUPERSTRUCTURE DESIGN

- A. Develop General Section
 - 1. Roadway Width (Highway Specified)
 - 2. Span Arrangements (2.3.2) (2.5.4) (2.5.5) (2.6)
 - 3. Select Bridge Type—assumed to be I- or Box Girder
- B. Develop Typical Section
 - 1. I-Girder
 - a. Composite (6.10.1.1) or Noncomposite (6.10.1.2)
 - b. Hybrid or Nonhybrid (6.10.1.3)
 - c. Variable Web Depth (6.10.1.4)
 - d. Cross-section Proportion Limits (6.10.2)
 - 2. Box Girder
 - a. Multiple Boxes or Single Box (6.11.1.1) (6.11.2.3)
 - b. Hybrid or Nonhybrid (6.10.1.3)
 - c. Variable Web Depth (6.10.1.4)
 - d. Cross-section Proportion Limits (6.11.2)
 - e. Bearings (6.11.1.2)
 - f. Orthotropic Deck (6.14.3)
- C. Design Conventionally Reinforced Concrete Deck
 - 1. Deck Slabs (4.6.2.1)
 - 2. Minimum Depth (9.7.1.1)

3. Empirical Design (9.7.2)
 4. Traditional Design (9.7.3)
 5. Strip Method (4.6.2.1)
 6. Live Load Application (3.6.1.3.3) (4.6.2.1.4) (4.6.2.1.5)
 7. Distribution Reinforcement (9.7.3.2)
 8. Overhang Design (A13.4) (3.6.1.3.4)
 9. Minimum Negative Flexure Concrete Deck Reinforcement (6.10.1.7)
- D. Select Resistance Factors
1. Strength Limit State (6.5.4.2)
- E. Select Load Modifiers
1. Ductility (1.3.3)
 2. Redundancy (1.3.4)
 3. Operational Importance (1.3.5)
- F. Select Load Combinations and Load Factors (3.4.1)
1. Strength Limit State (6.5.4.1) (6.10.6.1) (6.11.6.1)
 2. Service Limit State (6.10.4.2.1)
 3. Fatigue and Fracture Limit State (6.5.3)
- G. Calculate Live Load Force Effects
1. Select Live Loads (3.6.1) and Number of Lanes (3.6.1.1.1)
 2. Multiple Presence (3.6.1.1.2)
 3. Dynamic Load Allowance (3.6.2)
 4. Distribution Factor for Moment (4.6.2.2.2)
 - a. Interior Beams with Concrete Decks (4.6.2.2.2b)
 - b. Exterior Beams (4.6.2.2.2d)
 - c. Skewed Bridges (4.6.2.2.2e)
 5. Distribution Factor for Shear (4.6.2.2.3)
 - a. Interior Beams (4.6.2.2.3a)
 - b. Exterior Beams (4.6.2.2.3b)
 - c. Skewed Bridges (4.6.2.2.3c)

6. Stiffness (6.10.1.5)
7. Wind Effects (4.6.2.7)
8. Reactions to Substructure (3.6)

H. Calculate Force Effects From Other Loads Identified in Step C6.3.F

I. Design Required Sections—Illustrated for Design of I-Girder

1. Flexural Design
 - a. Composite Section Stresses (6.10.1.1.1)
 - b. Flange Stresses and Member Bending Moments (6.10.1.6)
 - c. Fundamental Section Properties (D6.1) (D6.2) (D6.3)
 - d. Constructibility (6.10.3)
 - (1) General (2.5.3) (6.10.3.1)
 - (2) Flexure (6.10.3.2) (6.10.1.8) (6.10.1.9) (6.10.1.10.1) (6.10.8.2) (A6.3.3—optional)
 - (3) Shear (6.10.3.3)
 - (4) Deck Placement (6.10.3.4)
 - (5) Dead Load Deflections (6.10.3.5)
 - e. Service Limit State (6.5.2) (6.10.4)
 - (1) Elastic Deformations (6.10.4.1)
 - (a) Optional Live-Load Deflection Control (2.5.2.6.2)
 - (b) Optional Criteria for Span-to-Depth Ratios (2.5.2.6.3)
 - (2) Permanent Deformations (6.10.4.2)
 - (a) General (6.10.4.2.1)
 - (b) Flexure (6.10.4.2.2) (Appendix B6—optional) (6.10.1.9) (6.10.1.10.1)
 - f. Fatigue and Fracture Limit State (6.5.3) (6.10.5)
 - (1) Fatigue (6.10.5.1) (6.6.1)
 - (2) Fracture (6.10.5.2) (6.6.2)
 - (3) Special Fatigue Requirement for Webs (6.10.5.3)
 - g. Strength Limit State (6.5.4) (6.10.6)
 - (1) Composite Sections in Positive Flexure (6.10.6.2.2) (6.10.7)

- (2) Composite Sections in Negative Flexure and Noncomposite Sections (6.10.6.2.3) (6.10.8) (Appendix A6—optional) (Appendix B6—optional) (D6.4—optional)
 - (3) Net Section Fracture (6.10.1.8)
 - (4) Flange-Strength Reduction Factors (6.10.1.10)
2. Shear Design
- a. General (6.10.9.1)
 - b. Unstiffened Web (6.10.9.2)
 - c. Stiffened Web (6.10.9.3)
 - (1) General (6.10.9.3.1)
 - (2) Interior Panels (6.10.9.3.2)
 - (3) End Panels (6.10.9.3.3)
 - d. Stiffener Design (6.10.11)
 - (1) Transverse Intermediate Stiffeners (6.10.11.1)
 - (2) Bearing Stiffeners (6.10.11.2) (D6.5)
 - (3) Longitudinal Stiffeners (6.10.11.3)
3. Shear Connectors (6.10.10)
- a. General (6.10.10.1)
 - b. Fatigue Resistance (6.10.10.2)
 - c. Special Requirements for Points of Permanent Load Contraflexure (6.10.10.3)
 - d. Strength Limit State (6.10.10.4)

J. Dimension and Detail Requirements

- 1. Material Thickness (6.7.3)
- 2. Bolted Connections (6.13.2)
 - a. Minimum Design Capacity (6.13.1)
 - b. Net Sections (6.8.3)
 - c. Bolt Spacing Limits (6.13.2.6)
 - d. Slip Critical Bolt Resistance (6.13.2.2) (6.13.2.8)
 - e. Shear Resistance (6.13.2.7)
 - f. Bearing Resistance (6.13.2.9)

- g. Tensile Resistance (6.13.2.10)
- 3. Welded Connections (6.13.3)
- 4. Block Shear Rupture Resistance (6.13.4)
- 5. Connection Elements (6.13.5)
- 6. Splices (6.13.6)
 - a. Bolted Splices (6.13.6.1)
 - b. Welded Splices (6.13.6.2)
- 7. Cover Plates (6.10.12)
- 8. Diaphragms and Cross-frames (6.7.4)
- 9. Lateral Bracing (6.7.5)

C6.4—FLOWCHARTS FOR FLEXURAL DESIGN OF I-SECTIONS

C6.4.1—Flowchart for LRFD Article 6.10.3

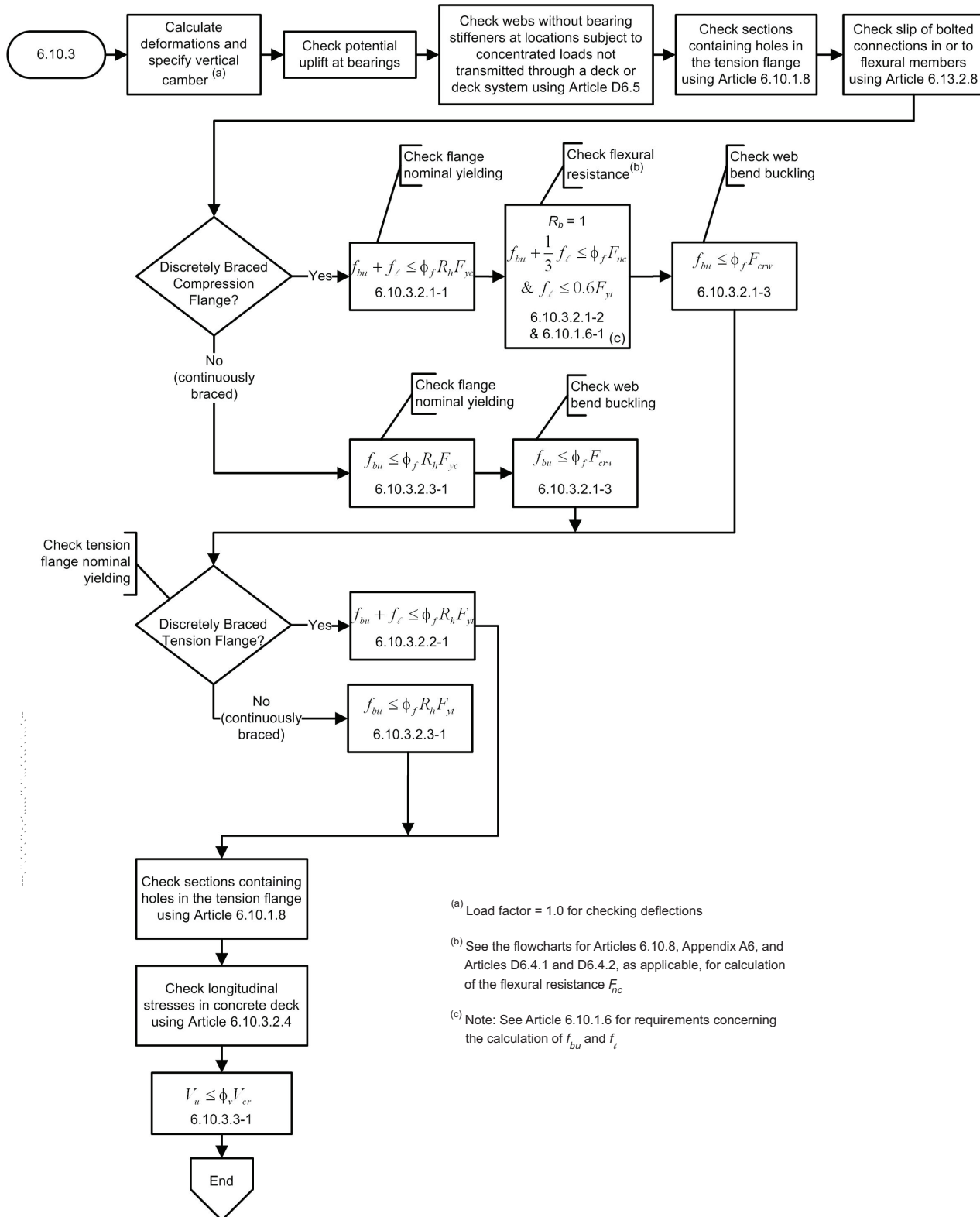

Figure C6.4.1-1—Flowchart for LRFD Article 6.10.3—Constructibility

C6.4.2—Flowchart for LRFD Article 6.10.4

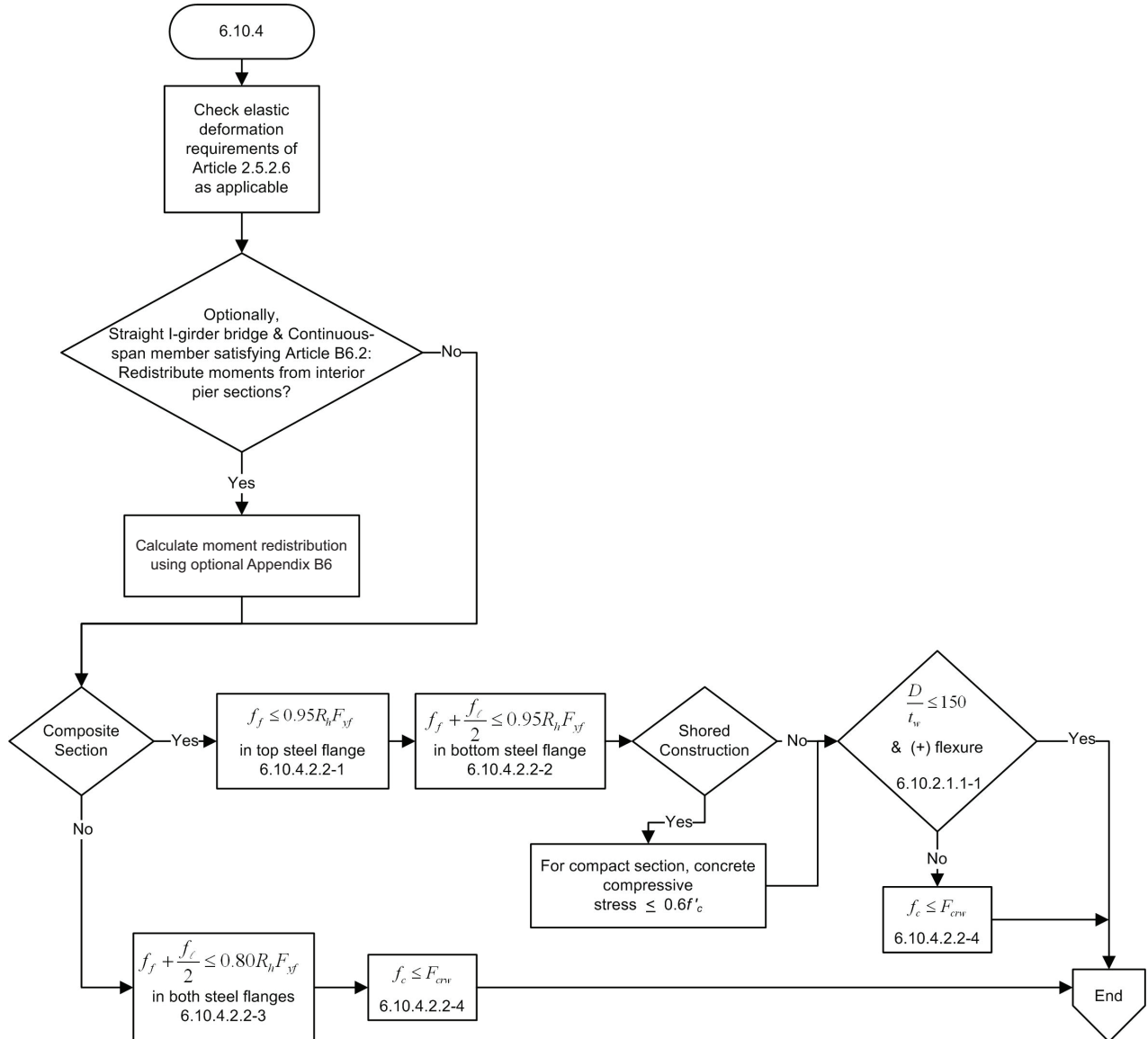
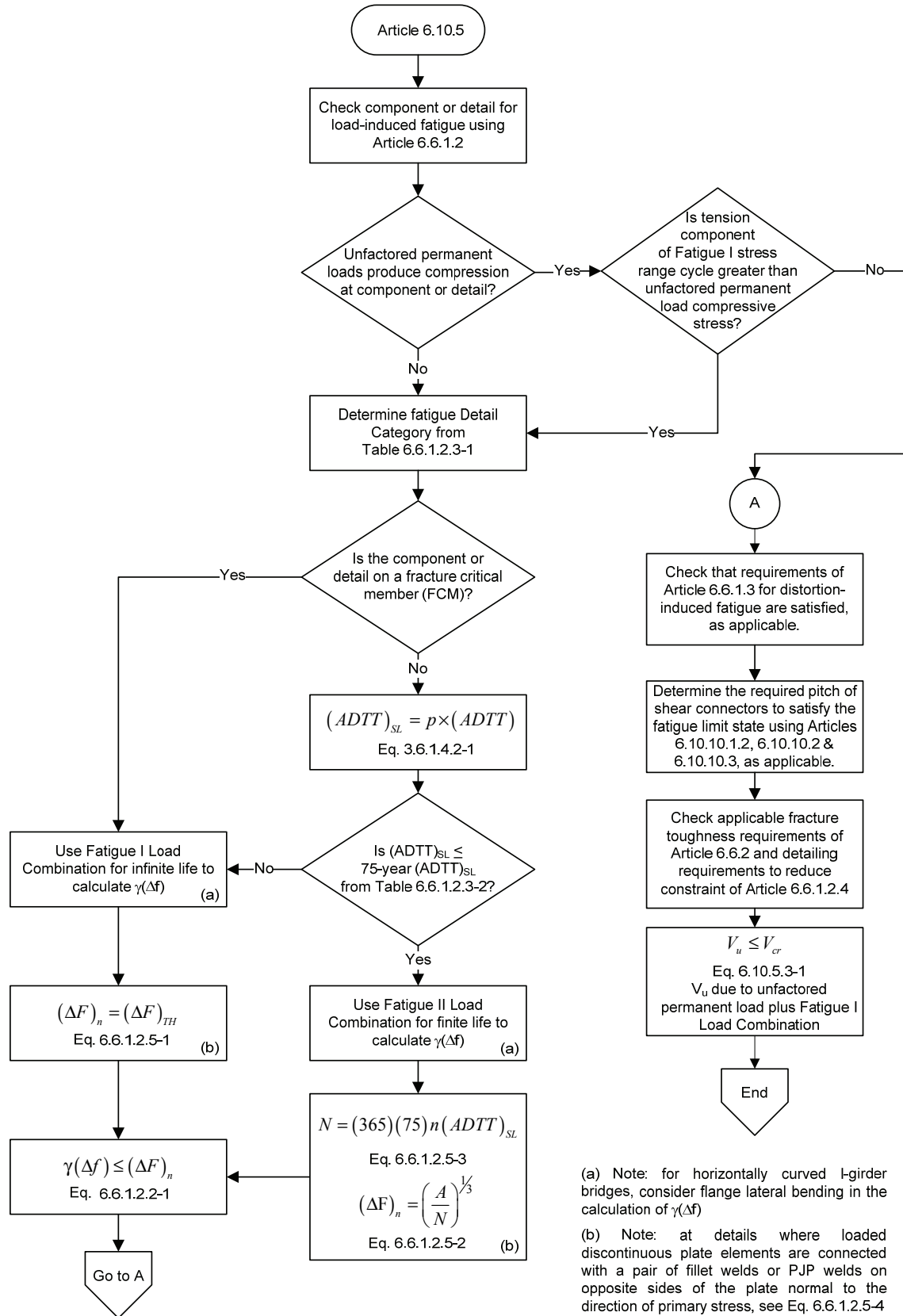

Figure C6.4.2-1—Flowchart for LRFD Article 6.10.4—Service Limit State

C6.4.3—Flowchart for LRFD Article 6.10.5



(a) Note: for horizontally curved I-girder bridges, consider flange lateral bending in the calculation of $\gamma(\Delta f)$

(b) Note: at details where loaded discontinuous plate elements are connected with a pair of fillet welds or PJP welds on opposite sides of the plate normal to the direction of primary stress, see Eq. 6.6.1.2.5-4

Figure C6.4.3-1—Flowchart for LRFD Article 6.10.5—Fatigue and Fracture Limit State

C6.4.4—Flowchart for LRFD Article 6.10.6

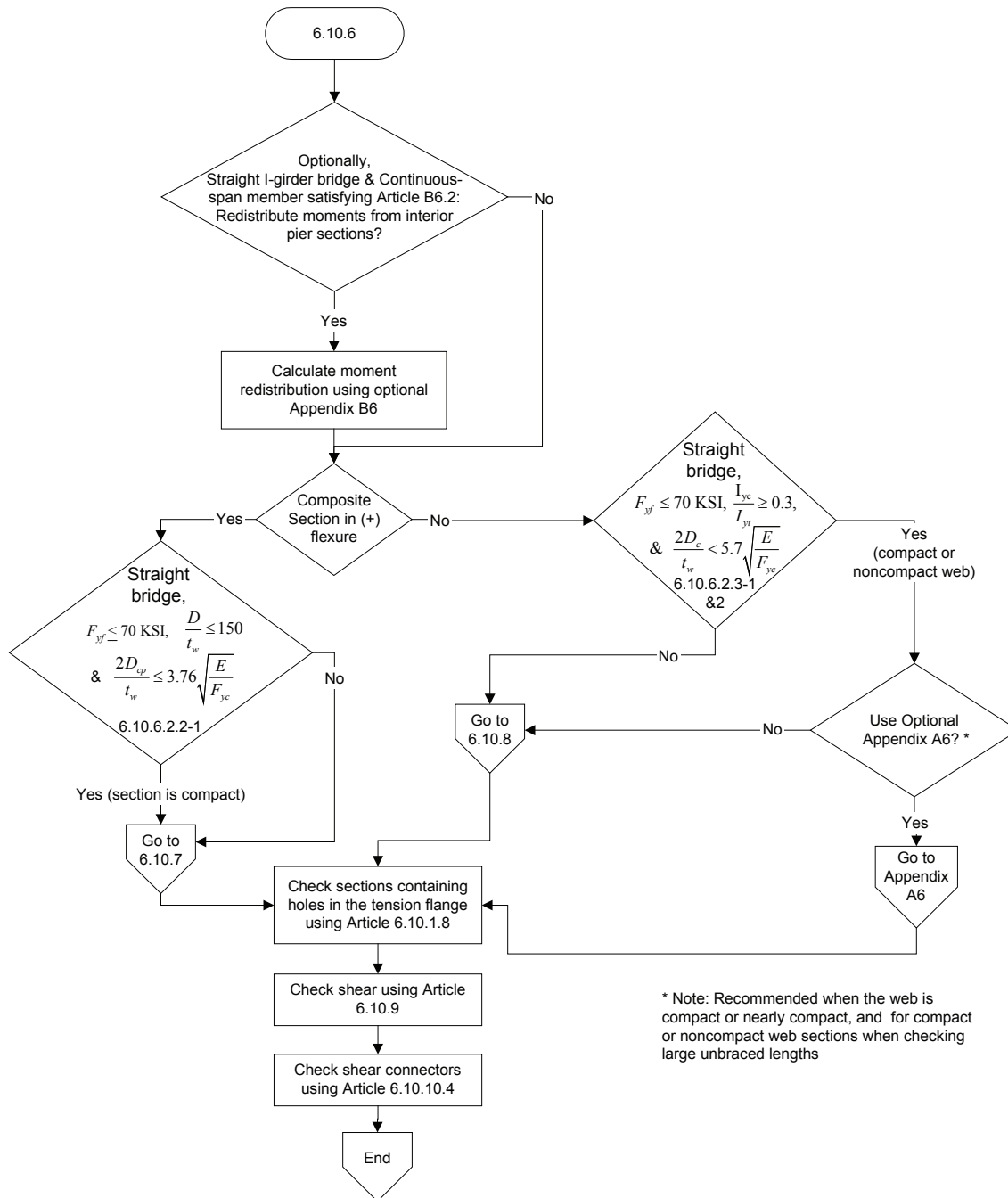

Figure C6.4.4-1—Flowchart for LRFD Article 6.10.6—Strength Limit State

C6.4.5—Flowchart for LRFD Article 6.10.7

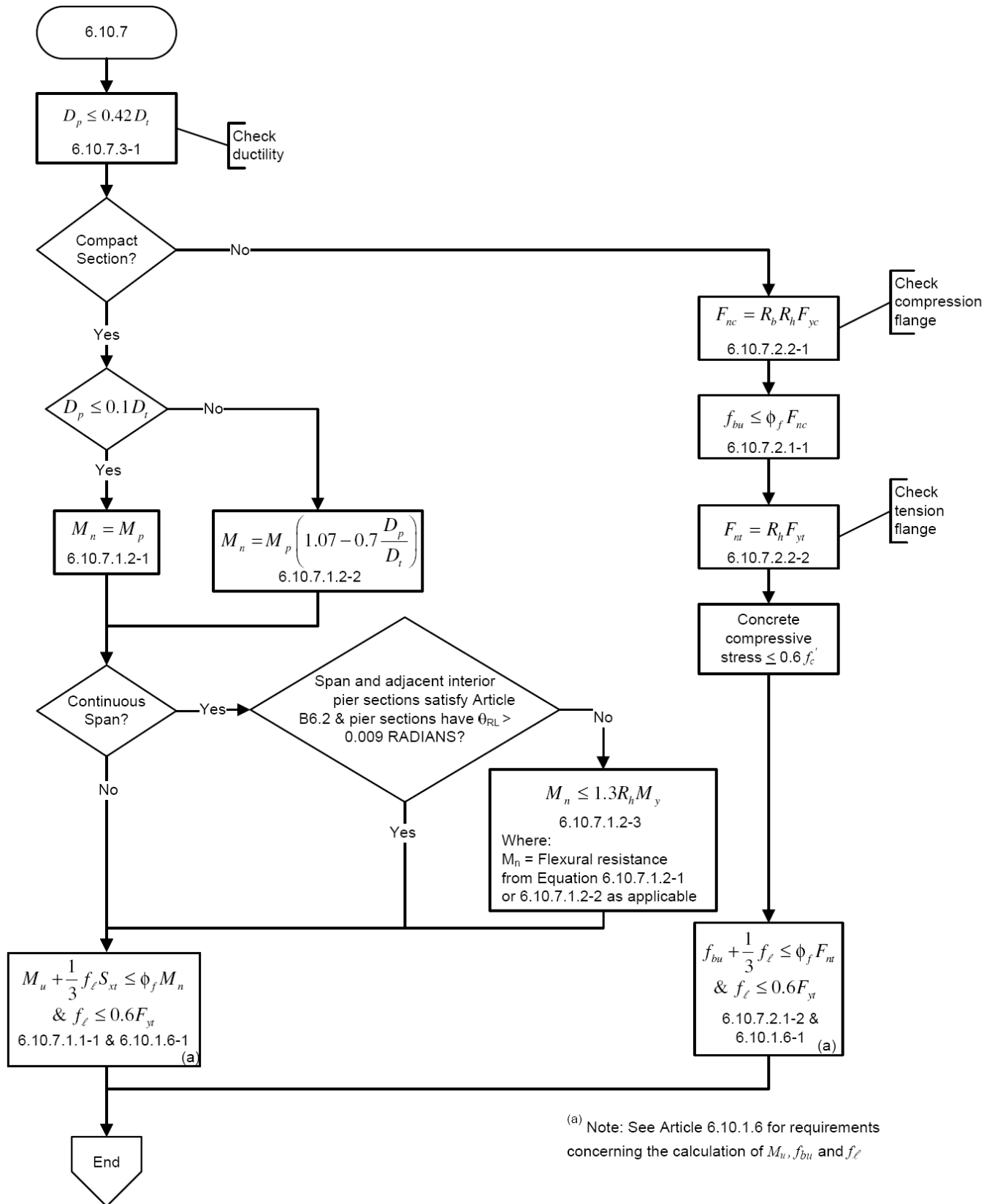

Figure C6.4.5-1—Flowchart for LRFD Article 6.10.7—Composite Sections in Positive Flexure

C6.4.6—Flowchart for LRFD Article 6.10.8

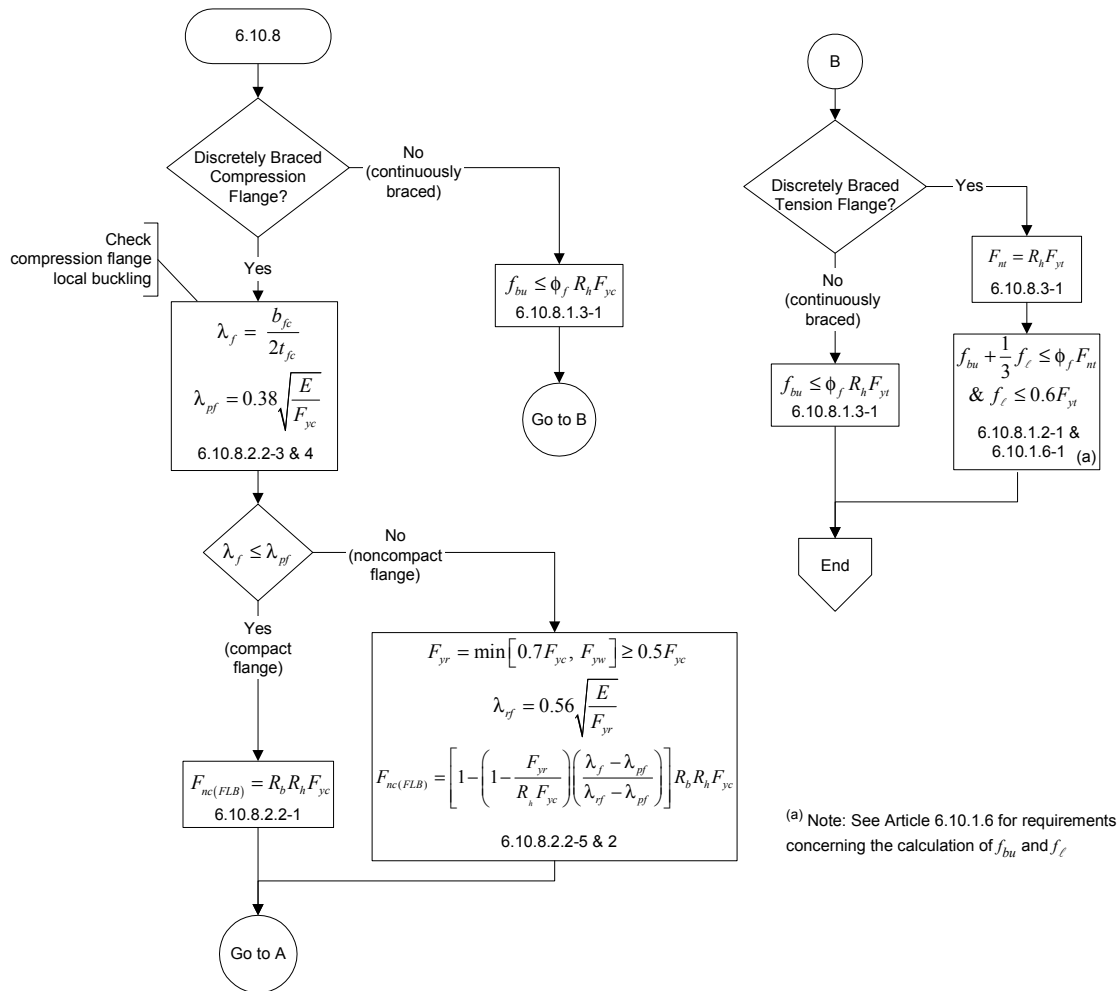

Figure C6.4.6-1—Flowchart for LRFD Article 6.10.8—Composite Sections in Negative Flexure and Noncomposite Sections

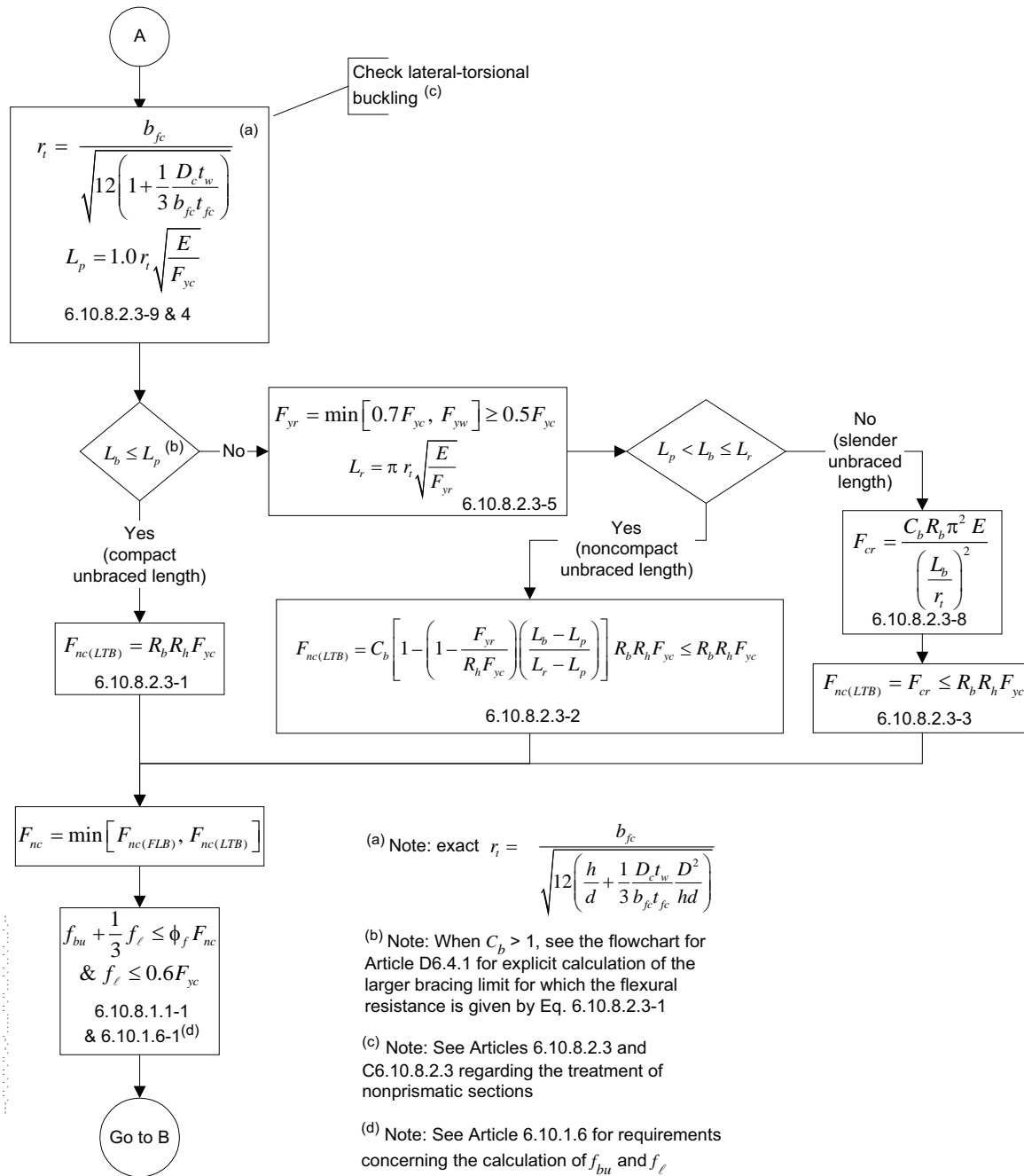

Figure C6.4.6-1 (continued)—Flowchart for LRFD Article 6.10.8—Composite Sections in Negative Flexure and Noncomposite Sections

C6.4.7—Flowchart for Appendix A6

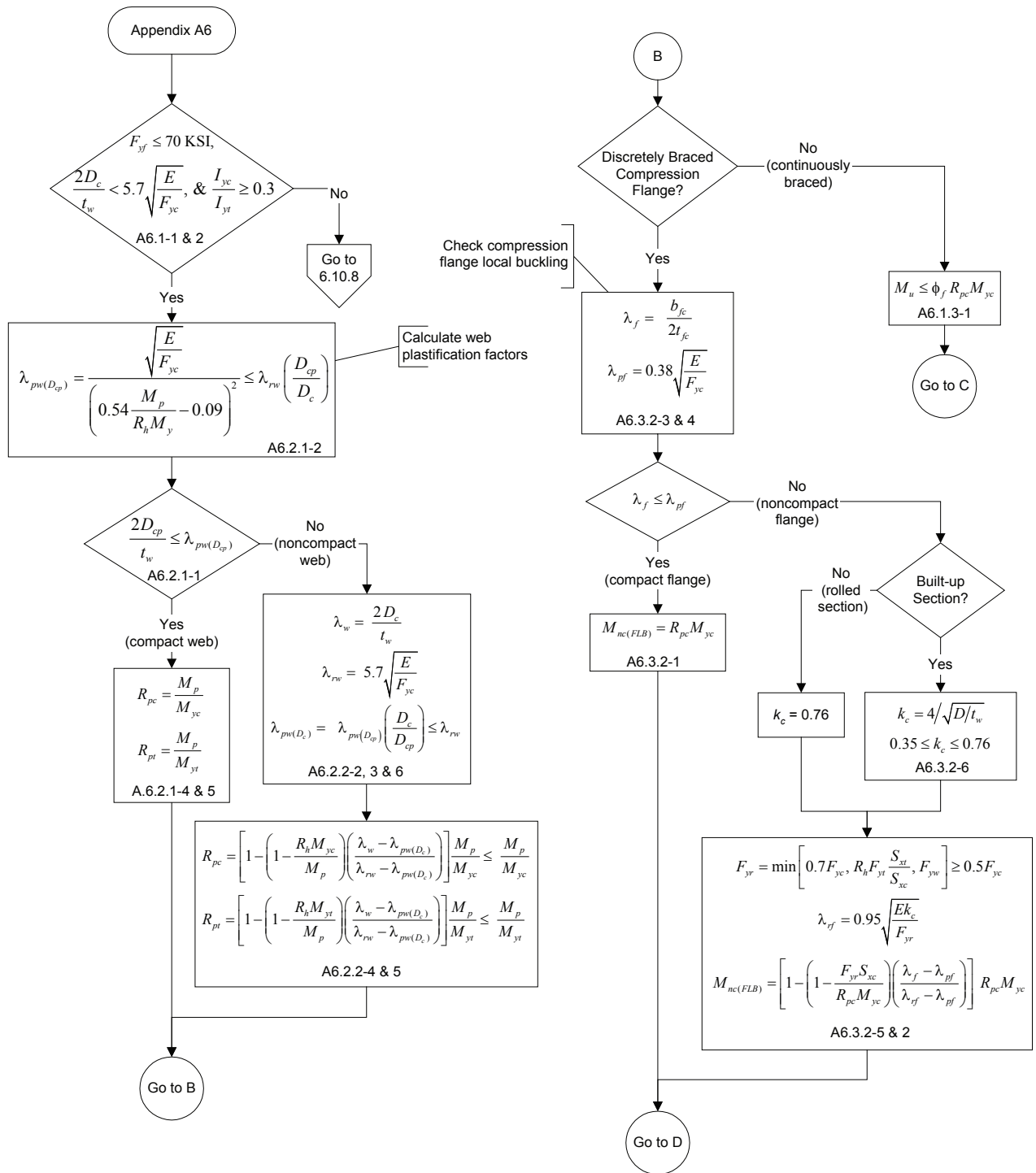

Figure C6.4.7-1—Flowchart for Appendix A6—Flexural Resistance of Straight Composite I-Sections in Negative Flexure and Straight Noncomposite I-Sections with Compact or Noncompact Webs

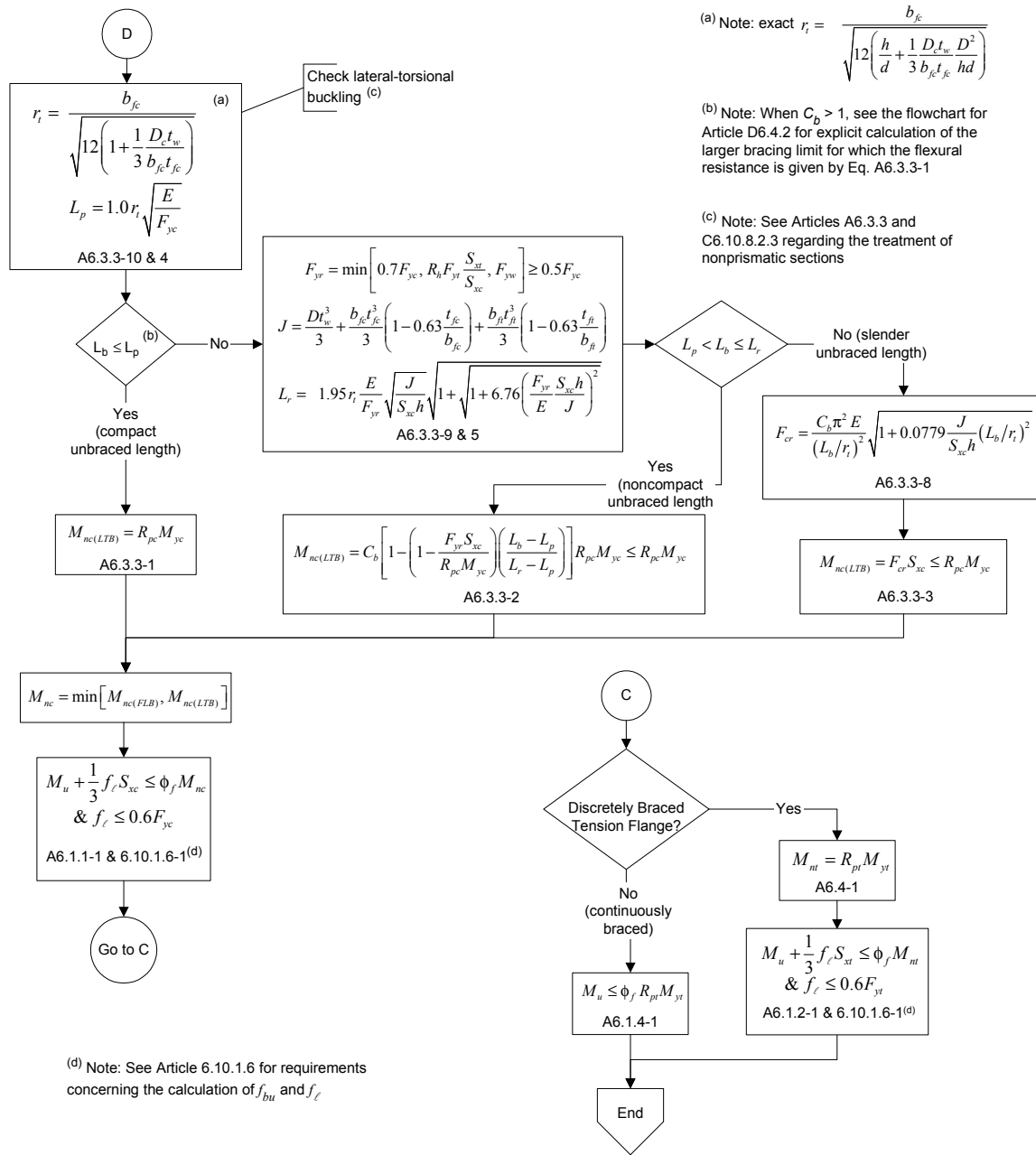

Figure C6.4.7-1 (continued)—Flowchart for Appendix A6—Flexural Resistance of Straight Composite I-Sections in Negative Flexure and Straight Noncomposite I-Sections with Compact or Noncompact Webs

C6.4.8—Flowchart for Article D6.4.1

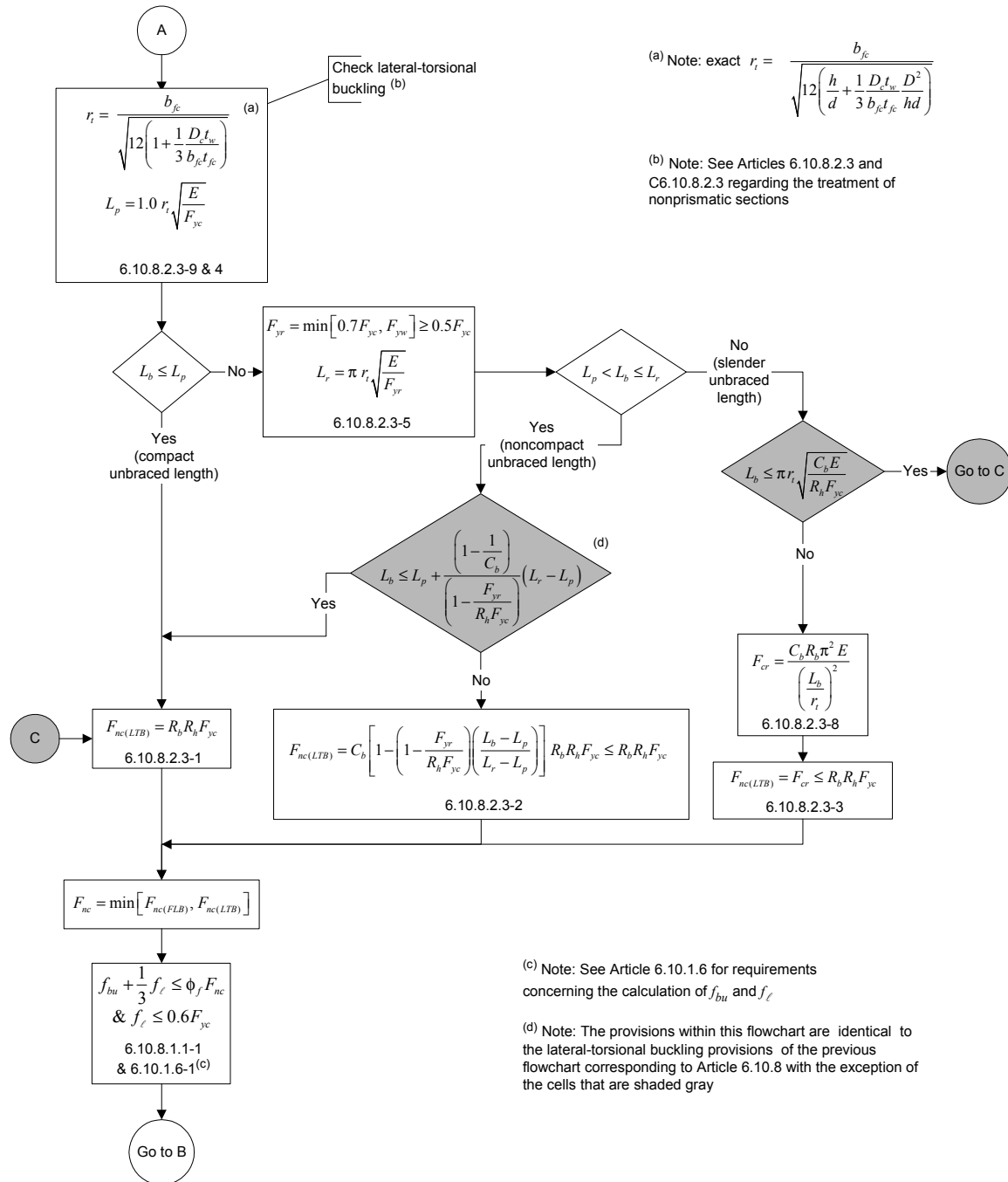

Figure C6.4.8-1—Flowchart for Article D6.4.1—LTB Provisions of Article 6.10.8.2.3 with Emphasis on Unbraced Length Requirements for Development of the Maximum Flexural Resistance

C6.4.9—Flowchart for Article D6.4.2

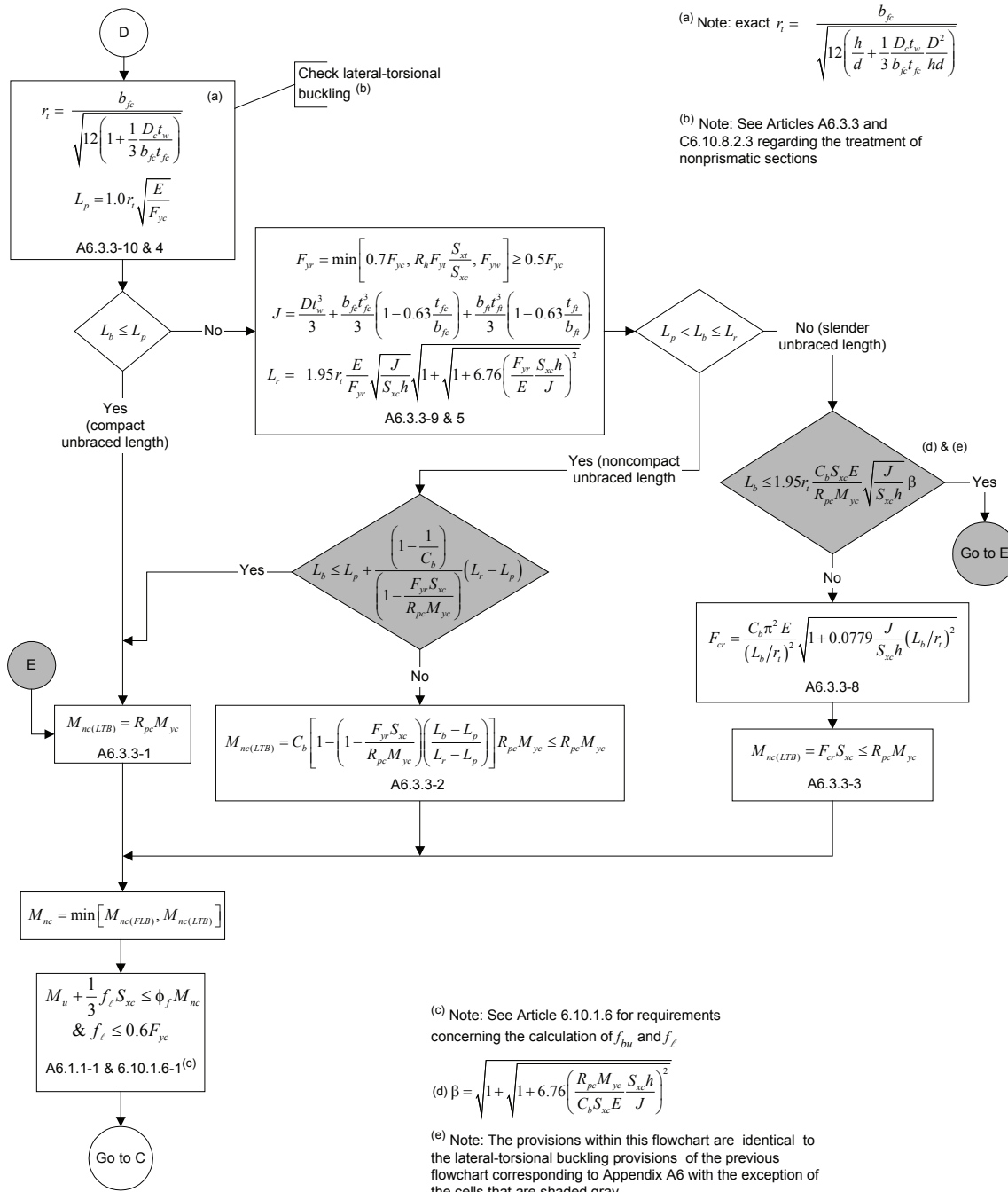

Figure C6.4.9-1—Flowchart for Article D6.4.2—LTB Provisions of Article A6.3.3 with Emphasis on Unbraced Length Requirements for Development of the Maximum Flexural Resistance

C6.4.10—Moment Gradient Modifier, C_b (Sample Cases)

Unbraced cantilevers and members where $f_{mid}/f_2 > 1$ or $f_2 = 0$: $C_b = 1$

Otherwise: $C_b = 1.75 - 1.05(f_1/f_2) + 0.3(f_1/f_2)^2 \leq 2.3$

If variation of moment is concave between brace points: $f_1 = f_0$

Otherwise: $f_1 = 2f_{mid} - f_2 \geq f_0$

Examples:

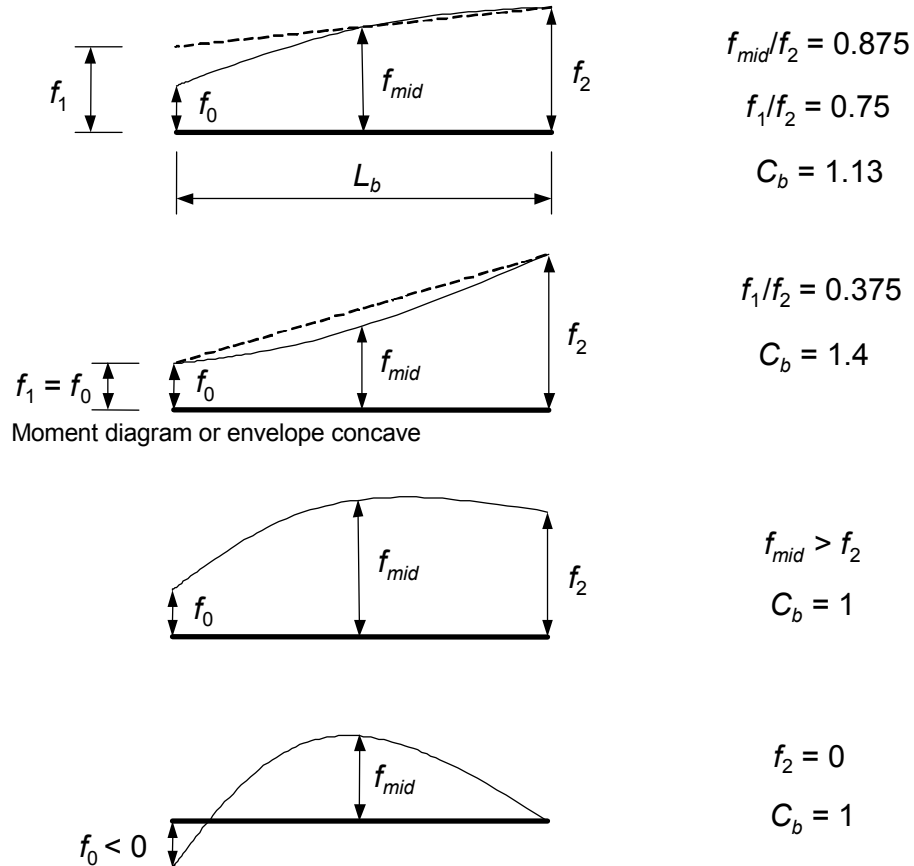
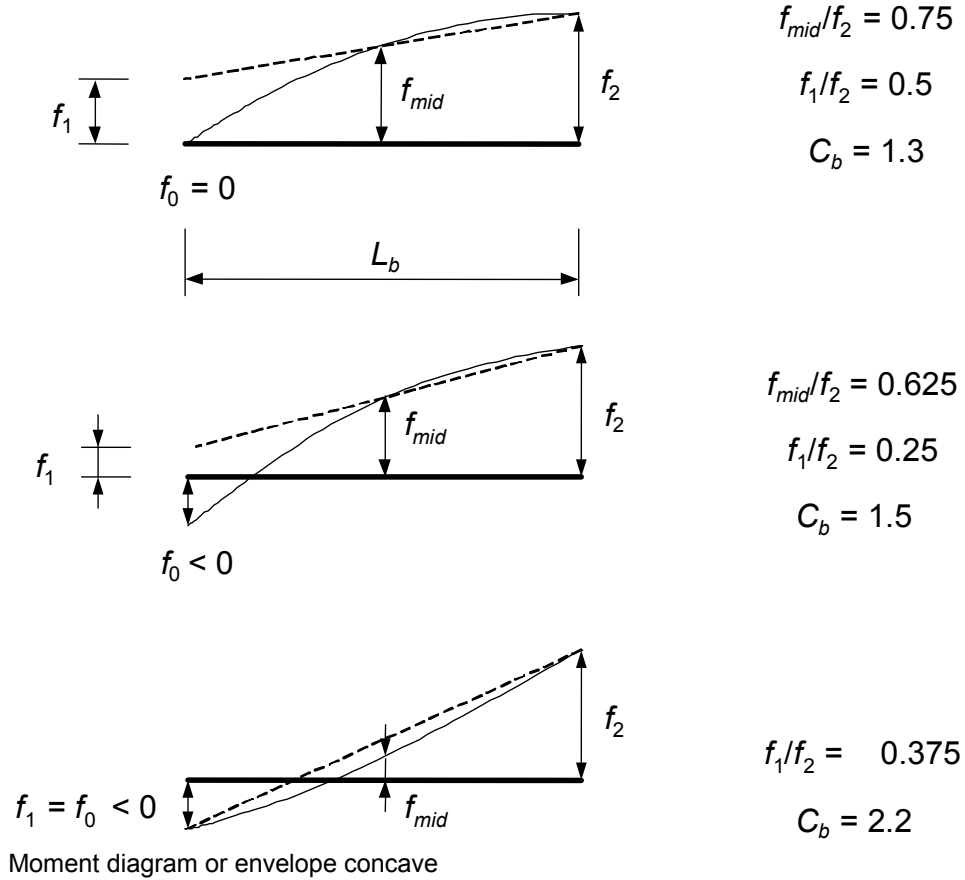

Figure C6.4.10-1—Moment Gradient Modifier, C_b (Sample Cases)



Note: The above examples assume that the member is prismatic within the unbraced length, or the transition to a smaller section is within $0.2L_b$ from the braced point with the lower moment. Otherwise, use $C_b = 1$.

Figure C6.4.10-1—(continued) Moment Gradient Modifier, C_b (Sample Cases)

APPENDIX D6—FUNDAMENTAL CALCULATIONS FOR FLEXURAL MEMBERS

D6.1—PLASTIC MOMENT

The plastic moment, M_p , shall be calculated as the moment of the plastic forces about the plastic neutral axis. Plastic forces in steel portions of a cross-section shall be calculated using the yield strengths of the flanges, the web, and reinforcing steel, as appropriate. Plastic forces in concrete portions of the cross-section that are in compression may be based on a rectangular stress block with the magnitude of the compressive stress equal to $0.85f'_c$. Concrete in tension shall be neglected.

The position of the plastic neutral axis shall be determined by the equilibrium condition that there is no net axial force.

The plastic moment of a composite section in positive flexure can be determined by:

- Calculating the element forces and using them to determine whether the plastic neutral axis is in the web, top flange or concrete deck;
- Calculating the location of the plastic neutral axis within the element determined in the first step; and
- Calculating M_p . Equations for the various potential locations of the plastic neutral axis (PNA) are given in Table D6.1-1.

The forces in the longitudinal reinforcement may be conservatively neglected. To do this, set P_{rb} and P_{rt} equal to zero in the equations in Table D6.1-1.

The plastic moment of a composite section in negative flexure can be calculated by an analogous procedure. Equations for the two cases most likely to occur in practice are given in Table D6.1-2.

The plastic moment of a noncomposite section may be calculated by eliminating the terms pertaining to the concrete deck and longitudinal reinforcement from the equations in Tables D6.1-1 and D6.1-2 for composite sections.

In the equations for M_p given in Tables D6.1-1 and D6.1-2, d is the distance from an element force to the plastic neutral axis. Element forces act at (a) mid-thickness for the flanges and the concrete deck, (b) mid-depth of the web, and (c) center of reinforcement. All element forces, dimensions, and distances should be taken as positive. The condition should be checked in the order listed in Tables D6.1-1 and D6.1-2.

Table D6.1.1—Calculation of \bar{Y} and M_p for Sections in Positive Flexure

Case	PNA	Condition	\bar{Y} and M_p
I	In Web	$P_t + P_w \geq P_c + P_s + P_{rb} + P_{rt}$	$\bar{Y} = \left(\frac{D}{2}\right) \left[\frac{P_t - P_c - P_s - P_{rt} - P_{rb}}{P_w} + 1 \right]$ $M_p = \frac{P_w}{2D} \left[\bar{Y}^2 + (D - \bar{Y})^2 \right] + [P_s d_s + P_{rt} d_{rt} + P_{rb} d_{rb} + P_c d_c + P_t d_t]$
II	In Top Flange	$P_t + P_w + P_c \geq P_s + P_{rb} + P_{rt}$	$\bar{Y} = \left(\frac{t_c}{2}\right) \left[\frac{P_w + P_t - P_s - P_{rt} - P_{rb}}{P_c} + 1 \right]$ $M_p = \frac{P_c}{2t_c} \left[\bar{Y}^2 + (t_c - \bar{Y})^2 \right] + [P_s d_s + P_{rt} d_{rt} + P_{rb} d_{rb} + P_w d_w + P_t d_t]$
III	Concrete Deck, Below P_{rb}	$P_t + P_w + P_c \geq \left(\frac{c_{rb}}{t_s}\right) P_s + P_{rb} + P_{rt}$	$\bar{Y} = (t_s) \left[\frac{P_c + P_w + P_t - P_{rt} - P_{rb}}{P_s} \right]$ $M_p = \left(\frac{\bar{Y}^2 P_s}{2t_s}\right) + [P_{rt} d_{rt} + P_{rb} d_{rb} + P_c d_c + P_w d_w + P_t d_t]$
IV	Concrete Deck, at P_{rb}	$P_t + P_w + P_c + P_{rb} \geq \left(\frac{c_{rb}}{t_s}\right) P_s + P_{rt}$	$\bar{Y} = c_{rb}$ $M_p = \left(\frac{\bar{Y}^2 P_s}{2t_s}\right) + [P_{rt} d_{rt} + P_c d_c + P_w d_w + P_t d_t]$
V	Concrete Deck, Above P_{rb} Below P_{rt}	$P_t + P_w + P_c + P_{rb} \geq \left(\frac{c_{rt}}{t_s}\right) P_s + P_{rt}$	$\bar{Y} = (t_s) \left[\frac{P_{rb} + P_c + P_w + P_t - P_{rt}}{P_s} \right]$ $M_p = \left(\frac{\bar{Y}^2 P_s}{2t_s}\right) + [P_{rt} d_{rt} + P_{rb} d_{rb} + P_c d_c + P_w d_w + P_t d_t]$
VI	Concrete Deck, at P_{rt}	$P_t + P_w + P_c + P_{rb} + P_{rt} \geq \left(\frac{c_{rt}}{t_s}\right) P_s$	$\bar{Y} = c_{rt}$ $M_p = \left(\frac{\bar{Y}^2 P_s}{2t_s}\right) + [P_{rb} d_{rb} + P_c d_c + P_w d_w + P_t d_t]$
VII	Concrete Deck, Above P_{rt}	$P_t + P_w + P_c + P_{rb} + P_{rt} < \left(\frac{c_{rt}}{t_s}\right) P_s$	$\bar{Y} = (t_s) \left[\frac{P_{rb} + P_c + P_w + P_t + P_{rt}}{P_s} \right]$ $M_p = \left(\frac{\bar{Y}^2 P_s}{2t_s}\right) + [P_{rt} d_{rt} + P_{rb} d_{rb} + P_c d_c + P_w d_w + P_t d_t]$

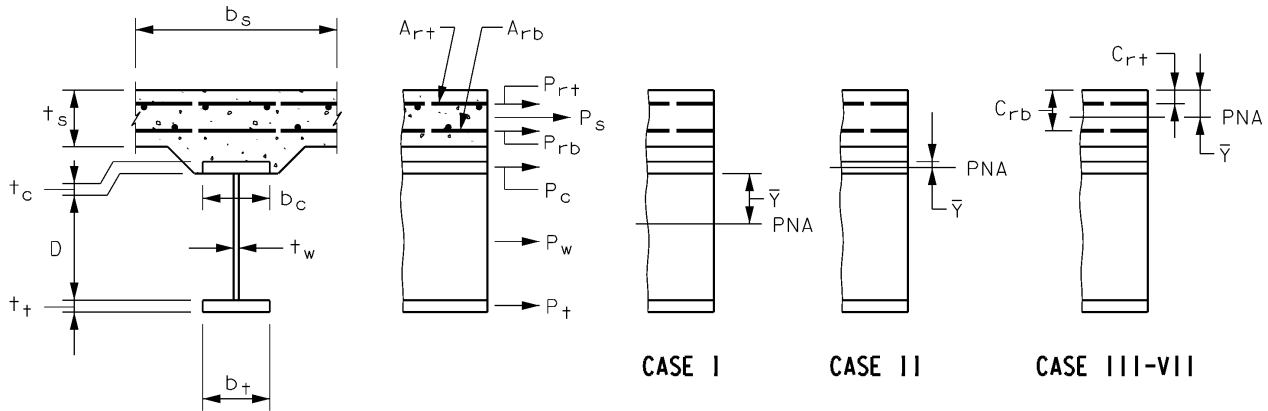
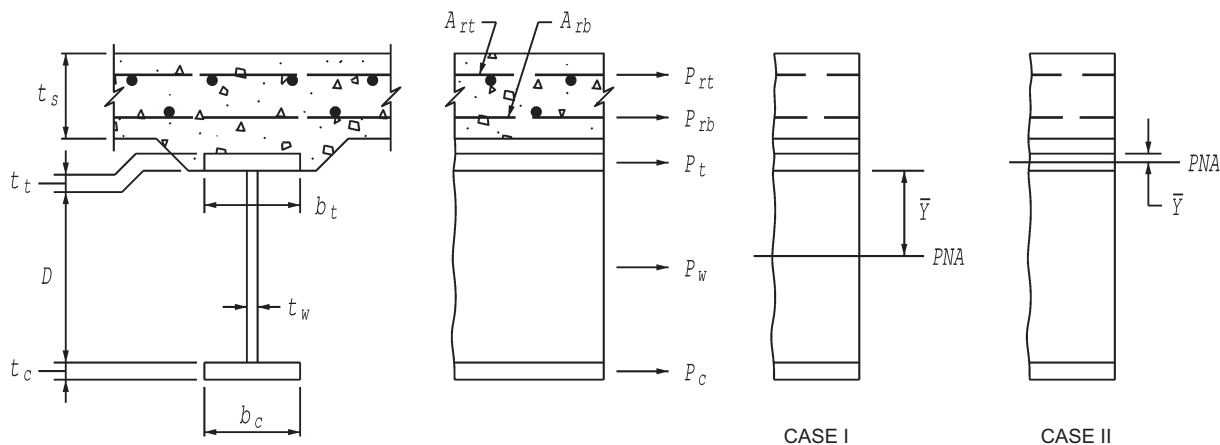

Table D6.1-2—Calculation of \bar{Y} and M_p for Sections in Negative Flexure

Case	PNA	Condition	\bar{Y} and M_p
I	In Web	$P_c + P_w \geq P_t + P_{rb} + P_{rt}$	$\bar{Y} = \left(\frac{D}{2}\right) \left[\frac{P_c - P_t - P_{rt} - P_{rb}}{P_w} + 1 \right]$ $M_p = \frac{P_w}{2D} \left[\bar{Y}^2 + (D - \bar{Y})^2 \right] + [P_{rt}d_{rt} + P_{rb}d_{rb} + P_t d_t + P_c d_c]$
II	In Top Flange	$P_c + P_w + P_t \geq P_{rb} + P_{rt}$	$\bar{Y} = \left(\frac{t_t}{2}\right) \left[\frac{P_w + P_c - P_{rt} - P_{rb}}{P_t} + 1 \right]$ $M_p = \frac{P_t}{2t_t} \left[\bar{Y}^2 + (t_t - \bar{Y})^2 \right] + [P_{rt}d_{rt} + P_{rb}d_{rb} + P_w d_w + P_c d_c]$



in which:

$$P_{rt} = F_{yrt} A_{rt}$$

$$P_s = 0.85 f'_c b_s t_s$$

$$P_{rb} = F_{yrb} A_{rb}$$

$$P_c = F_{yc} b_c t_c$$

$$P_w = F_{yw} D t_w$$

$$P_t = F_{yt} b_t t_t$$

D6.2—YIELD MOMENT

D6.2.1—Noncomposite Sections

The yield moment, M_y , of a noncomposite section shall be taken as the smaller of the moment required to cause nominal first yielding in the compression flange, M_{yc} , and the moment required to cause nominal first yielding in the tension flange, M_{yt} , at the strength limit state. Flange lateral bending in all types of sections and web yielding in hybrid sections shall be disregarded in this calculation.

D6.2.2—Composite Sections in Positive Flexure

The yield moment of a composite section in positive flexure shall be taken as the sum of the moments applied separately to the steel and the short-term and long-term composite sections to cause nominal first yielding in either steel flange at the strength limit state. Flange lateral bending in all types of sections and web yielding in hybrid sections shall be disregarded in this calculation.

The yield moment of a composite section in positive flexure may be determined as follows:

- Calculate the moment M_{D1} caused by the factored permanent load applied before the concrete deck has hardened or is made composite. Apply this moment to the steel section.
- Calculate the moment M_{D2} caused by the remainder of the factored permanent load. Apply this moment to the long-term composite section.
- Calculate the additional moment M_{AD} that must be applied to the short-term composite section to cause nominal yielding in either steel flange.
- The yield moment is the sum of the total permanent load moment and the additional moment.

Symbolically, the procedure is:

- 1) Solve for M_{AD} from the equation:

$$F_y = \frac{M_{D1}}{S_{NC}} + \frac{M_{D2}}{S_{LT}} + \frac{M_{AD}}{S_{ST}} \quad (\text{D6.2.2-1})$$

- 2) Then calculate:

$$M_y = M_{D1} + M_{D2} + M_{AD} \quad (\text{D6.2.2-2})$$

where:

- S_{NC} = noncomposite section modulus (in.³)
 S_{ST} = short-term composite section modulus (in.³)
 S_{LT} = long-term composite section modulus (in.³)
 M_{D1} , M_{D2}
 & M_{AD} = moments due to the factored loads applied to the appropriate sections (kip-in.)

M_y shall be taken as the lesser value calculated for the compression flange, M_{yc} , or the tension flange, M_{yt} .

D6.2.3—Composite Sections in Negative Flexure

For composite sections in negative flexure, the procedure specified in Article D6.2.2 is followed, except that the composite section for both short-term and long-term moments shall consist of the steel section and the longitudinal reinforcement within the effective width of the concrete deck. Thus, S_{ST} and S_{LT} are the same value.

Also, M_{yt} shall be taken with respect to either the tension flange or the longitudinal reinforcement, whichever yields first.

D6.2.4—Sections with Cover Plates

For sections containing flange cover plates, M_{yc} or M_{yt} shall be taken as the smallest value of moment associated with nominal first yielding based on the stress in either the flange under consideration or in any of the cover plates attached to that flange, whichever yields first. Flange lateral bending in all types of sections and web yielding in hybrid sections shall be disregarded in this calculation.

D6.3—DEPTH OF THE WEB IN COMPRESSION

D6.3.1—In the Elastic Range (D_c)

For composite sections in positive flexure, the depth of the web in compression in the elastic range, D_c , shall be the depth over which the algebraic sum of the stresses in the steel, long-term composite and short-term composite sections from the dead and live loads, plus impact, is compressive.

In lieu of computing D_c at sections in positive flexure from stress diagrams, the following equation may be used:

$$D_c = \left(\frac{-f_c}{|f_c| + f_t} \right) d - t_{fc} \geq 0 \quad (\text{D6.3.1-1})$$

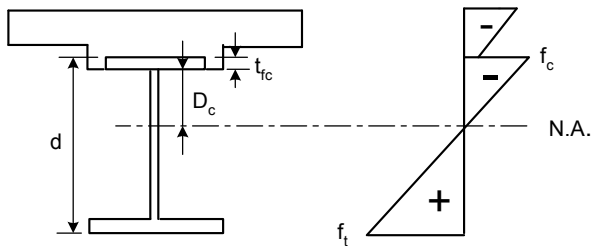

Figure D6.3.1-1—Computation of D_c at Sections in Positive Flexure

where:

- d = depth of the steel section (in.)
- f_c = sum of the compression-flange stresses caused by the different loads, i.e., $DC1$, the permanent load acting on the noncomposite section; $DC2$, the permanent load acting on the long-term composite section; DW , the wearing surface load; and $LL+IM$, acting on their respective sections (ksi). f_c shall be taken as negative when the stress is in compression. Flange lateral bending shall be disregarded in this calculation.
- f_t = the sum of the tension-flange stresses caused by the different loads (ksi). Flange lateral bending shall be disregarded in this calculation.

CD6.3.1

At sections in positive flexure, D_c of the composite section will increase with increasing span length because of the increasing dead-to-live load ratio. Therefore, in general it is important to recognize the effect of the dead-load stress on the location of the neutral axis of the composite section in regions of positive flexure.

According to these Specifications, for composite sections in positive flexure, Eq. D6.3.1-1 only need be employed for checking web bend-buckling at the service limit state and for computing the R_b factor at the strength limit state for sections in which web longitudinal stiffeners are required based on Article 6.10.2.1.1. Eq. D6.3.1-1 is never needed for composite sections in positive flexure when the web satisfies the requirement of Article 6.10.2.1.1 such that longitudinal stiffeners are not required. Articles C6.10.1.9.2, C6.10.1.10.2, and C6.10.4.2.2 discuss the rationale for these calculations, which introduce a dependency of the flexural resistance on the applied load whenever $R_b < 1$, and therefore, potentially complicate subsequent rating calculations for these section types. Article C6.10.1.9.1 explains why the calculation of D_c is not required for composite sections in positive flexure when the web satisfies Article 6.10.2.1.1.

For composite sections in negative flexure, the concrete deck is typically not considered to be effective in tension. Therefore, the distance between the neutral axis locations for the steel and composite sections is small in this case and the location of the neutral axis for the composite section is largely unaffected by the dead-load stress. Therefore, for the majority of situations, these Specifications specify the use of D_c computed simply for the section consisting of the steel girder plus the longitudinal reinforcement, without considering the algebraic sum of the stresses acting on the noncomposite and composite sections. This eliminates potential difficulties in subsequent load rating since the resulting D_c is independent of the applied loading, and therefore the flexural resistance in negative bending, which depends on D_c , does not depend on the applied load. The single

For composite sections in negative flexure, D_c shall be computed for the section consisting of the steel girder plus the longitudinal reinforcement with the exception of the following. For composite sections in negative flexure at the service limit state where the concrete deck is considered effective in tension for computing flexural stresses on the composite section due to Load Combination Service II, D_c shall be computed from Eq. D6.3.1-1.

exception is that if the concrete deck is assumed effective in tension in regions of negative flexure at the service limit state, as permitted for composite sections satisfying the requirements specified in Article 6.10.4.2.1, Eq. D6.3.1-1 must be used to compute D_c . For this case, in Figure D6.3.1-1, the stresses f_c and f_t should be switched, the signs shown in the stress diagram should be reversed, t_{fc} should be the thickness of the bottom flange, and D_c should instead extend from the neutral axis down to the top of the bottom flange.

D6.3.2—At Plastic Moment (D_{cp})

For composite sections in positive flexure, the depth of the web in compression at the plastic moment, D_{cp} , shall be taken as follows for cases from Table D6.1-1 where the plastic neutral axis is in the web:

$$D_{cp} = \frac{D}{2} \left(\frac{F_{yt}A_t - F_{yc}A_c - 0.85f'_cA_s - F_{yrs}A_{rs}}{F_{yw}A_w} + 1 \right) \quad (\text{D6.3.2-1})$$

where:

- A_c = area of the compression flange (in.²)
- A_{rs} = total area of the longitudinal reinforcement within the effective concrete deck width (in.²)
- A_s = area of the concrete deck (in.²)
- A_t = area of the tension flange (in.²)
- A_w = area of the web (in.²)
- D_{cp} = depth of the web in compression at the plastic moment (in.)
- F_{yrs} = specified minimum yield strength of the longitudinal reinforcement (ksi)

For all other composite sections in positive flexure, D_{cp} shall be taken equal to zero.

For composite sections in negative flexure, D_{cp} shall be taken as follows for cases from Table D6.1-2 where the plastic neutral axis is in the web:

$$D_{cp} = \frac{D}{2A_w F_{yw}} \left[F_{yt}A_t + F_{yw}A_w + F_{yrs}A_{rs} - F_{yc}A_c \right] \quad (\text{D6.3.2-2})$$

For all other composite sections in negative flexure, D_{cp} shall be taken equal to D .

For noncomposite sections where:

$$F_{yw}A_w \geq |F_{yc}A_c - F_{yt}A_t| \quad (\text{D6.3.2-3})$$

D_{cp} shall be taken as:

$$D_{cp} = \frac{D}{2A_w F_{yw}} [F_{yr} A_t + F_{yw} A_w - F_{yc} A_c] \quad (\text{D6.3.2-4})$$

For all other noncomposite sections, D_{cp} shall be taken equal to D .

D6.4—LATERAL TORSIONAL BUCKLING EQUATIONS FOR $C_b > 1.0$, WITH EMPHASIS ON UNBRACED LENGTH REQUIREMENTS FOR DEVELOPMENT OF THE MAXIMUM FLEXURAL RESISTANCE

D6.4.1—By the Provisions of Article 6.10.8.2.3

For unbraced lengths in which the member is prismatic, the lateral torsional buckling resistance of the compression flange shall be taken as:

- If $L_b \leq L_p$, then:

$$F_{nc} = R_b R_h F_{yc} \quad (\text{D6.4.1-1})$$

- If $L_p < L_b \leq L_r$, then:

$$\circ \text{ If } L_b \leq L_p + \left(1 - \frac{1}{C_b}\right) (L_r - L_p), \text{ then:}$$

$$\left(1 - \frac{F_{yr}}{R_h F_{yc}}\right)$$

$$F_{nc} = R_b R_h F_{yc} \quad (\text{D6.4.1-2})$$

- Otherwise:

$$F_{nc} = C_b \left[1 - \left(1 - \frac{F_{yr}}{R_h F_{yc}}\right) \left(\frac{L_b - L_p}{L_r - L_p}\right)\right] R_b R_h F_{yc} \leq R_b R_h F_{yc} \quad (\text{D6.4.1-3})$$

- If $L_b > L_r$, then:

$$\circ \text{ If } L_b \leq \pi r_t \sqrt{\frac{C_b E}{R_h F_{yc}}}, \text{ then:}$$

$$F_{nc} = R_b R_h F_{yc} \quad (\text{D6.4.1-4})$$

- Otherwise:

$$F_{nc} = F_{cr} \leq R_b R_h F_{yc} \quad (\text{D6.4.1-5})$$

All terms in the above equations shall be taken as defined in Article 6.10.8.2.3.

CD6.4.1

For values of the moment gradient modifier C_b greater than 1.0, the maximum LTB resistance F_{max} shown in Figure C6.10.8.2.1-1 may be reached at larger unbraced lengths. The provisions in this Article are equivalent to those in Articles 6.10.8.2.3, but allow the Engineer to focus on the conditions for which the LTB resistance is equal to $F_{max} = R_b R_h F_{yc}$ when the effects of moment gradient are included in determining the limits on L_b .

The largest unbraced length for which the LTB resistance of Article 6.10.8.2.3 is equal to the flange local buckling or FLB resistance of Article 6.10.8.2.2 may be determined by substituting $F_{nc(FLB)}/R_b$ for $R_h F_{yc}$ in checking the L_b requirement for the use of Eq. D6.4.1-2 or D6.4.1-4 as applicable, where $F_{nc(FLB)}$ is the FLB resistance obtained from Article 6.10.8.2.2.

If $D_c t_w / b_{fc} t_{fc}$ in Eq. 6.10.8.2.3-9 is taken as a representative value of 2.0, F_{yc} is taken as 50 ksi, and $F_{yw} > 0.7 F_{yc}$, the LTB resistance of Article 6.10.8.2.3 is equal to F_{max} for $L_b < 22 b_{fc}$ when $C_b > 1.75$ and $L_b < 17 b_{fc}$ for $C_b > 1.3$. The Engineer should note that, even with relatively small values of C_b , the unbraced length requirements to achieve a flexural resistance of F_{max} are significantly larger than those associated with uniform major-axis bending and $C_b = 1$. Article C6.10.8.2.3 discusses the appropriate calculation of $C_b > 1$ for bridge design.

D6.4.2—By the Provisions of Article A6.3.3

For unbraced lengths in which the member is prismatic, the flexural resistance based on lateral torsional buckling shall be taken as:

- If $L_b \leq L_p$, then:

$$M_{nc} = R_{pc} M_{yc} \quad (\text{D6.4.2-1})$$

- If $L_p < L_b \leq L_r$, then:

- If $L_b \leq L_p + \frac{\left(1 - \frac{1}{C_b}\right)}{\left(1 - \frac{F_{yr} S_{xc}}{R_{pc} M_{yc}}\right)} (L_r - L_p)$, then:

$$M_{nc} = R_{pc} M_{yc} \quad (\text{D6.4.2-2})$$

- Otherwise:

$$M_{nc} = C_b \left[1 - \left(1 - \frac{F_{yr} S_{xc}}{R_{pc} M_{yc}} \right) \left(\frac{L_b - L_p}{L_r - L_p} \right) \right] R_{pc} M_{yc} \leq R_{pc} M_{yc} \quad (\text{D6.4.2-3})$$

- If $L_b > L_r$, then:

- If:

$$L_b \leq 1.95 r_t \frac{C_b S_{xc} E}{R_{pc} M_{yc}} \sqrt{\frac{J}{S_{xc} h}} \sqrt{1 + \sqrt{1 + 6.76 \left(\frac{R_{pc} M_{yc} S_{xc} h}{C_b S_{xc} E J} \right)^2}}$$

then:

$$M_{nc} = R_{pc} M_{yc} \quad (\text{D6.4.2-4})$$

- Otherwise:

$$M_{nc} = F_{cr} S_{xc} \leq R_{pc} M_{yc} \quad (\text{D6.4.2-5})$$

All terms in the above equations shall be taken as defined in Article A6.3.3.

D6.5—CONCENTRATED LOADS APPLIED TO WEBS WITHOUT BEARING STIFFENERS**D6.5.1—General**

At bearing locations and at other locations subjected to concentrated loads, where the loads are not transmitted through a deck or deck system, webs without bearing stiffeners shall be investigated for the limit states of web local yielding and web crippling according to the provisions of Articles D6.5.2 and D6.5.3.

CD6.4.2

For values of the moment gradient modifier C_b greater than 1.0, the maximum LTB resistance M_{max} shown in Figure C6.10.8.2.1-1 may be reached at larger unbraced lengths. The provisions in this Article are equivalent to those in Article A6.3.3, but allow the Engineer to focus on the conditions for which the LTB resistance is equal to $M_{max} = R_{pc} M_{yc}$ when the effects of moment gradient are included in determining the limits on L_b .

The largest unbraced length for which the LTB resistance of Article A6.3.3 is equal to the flange local buckling or FLB resistance of Article A6.3.2 may be determined by substituting $M_{nc(FLB)}$ for $R_{pc} M_{yc}$ in checking the L_b requirement for the use of Eq. D6.4.2-2 or D6.4.2-4 as applicable, where $M_{nc(FLB)}$ is the FLB resistance obtained from Article A6.3.2.

Article A6.3.3 typically requires similar to somewhat smaller values than Article 6.10.8.2.3 for the limits on L_b required to reach the member resistance of $M_{max} > R_h M_{yc}$, depending on the magnitude of R_{pc} . If $D_e t_w / b_f c t_f c$ in Eq. A6.3.3-10 is taken as a representative value of 2.0, F_{yc} is taken as 50 ksi, and $F_{yw} > 0.7 F_{yc}$, then for $R_{pc} = 1.12$, the LTB resistance of this Article is typically equal to M_{max} when $L_b < 22 b_f c$ for $C_b > 1.75$ and when $L_b < 15 b_f c$ for $C_b > 1.30$. For $R_{pc} = 1.30$ and using the above assumptions, M_{max} is achieved by the LTB equations when $L_b < 20 b_f c$ for $C_b > 1.75$ and when $L_b < 13 b_f c$ for $C_b > 1.30$. The Engineer should note that, even with relatively small values of C_b , the unbraced length requirements to achieve a flexural resistance of M_{max} are significantly larger than those associated with uniform major-axis bending and $C_b = 1$. Article C6.10.8.2.3 discusses the appropriate calculation of $C_b > 1$ for bridge design.

CD6.5.1

The equations of this Article are essentially identical to the equations given in AISC (2005). The limit state of sidesway web buckling given in AISC (2005) is not included because it governs only for members subjected to concentrated loads directly applied to the steel section, and for members for which the compression flange is braced at

D6.5.2—Web Local Yielding

Webs subject to compressive or tensile concentrated loads shall satisfy:

$$R_u \leq \phi_b R_n \quad (\text{D6.5.2-1})$$

in which:

R_n = nominal resistance to the concentrated loading (kip)

- For interior-pier reactions and for concentrated loads applied at a distance from the end of the member that is greater than d :

$$R_n = (5k + N) F_{yw} t_w \quad (\text{D6.5.2-2})$$

- Otherwise:

$$R_n = (2.5k + N) F_{yw} t_w \quad (\text{D6.5.2-3})$$

where:

ϕ_b = resistance factor for bearing specified in Article 6.5.4.2

d = depth of the steel section (in.)

k = distance from the outer face of the flange resisting the concentrated load or bearing reaction to the web toe of the fillet (in.)

N = length of bearing (in.). N shall be greater than or equal to k at end bearing locations.

R_u = factored concentrated load or bearing reaction (kip)

D6.5.3—Web Crippling

Webs subject to compressive concentrated loads shall satisfy:

the load point, the tension flange is unbraced at this point, and the ratio of D/t_w to L_b/b_{fl} is less than or equal to 1.7. These conditions typically do not occur in bridge construction.

Built-up sections and rolled shapes without bearing stiffeners at the indicated locations should either be modified to comply with these requirements, or else bearing stiffeners designed according to the provisions of Article 6.10.11.2 should be placed on the web at the location under consideration.

For unusual situations in which diametrically opposed concentrated loads are directly applied to the web of the steel section at the level of each of the flanges, such as if a concentrated force were applied directly over a reaction point at an unstiffened location along the length of a girder, the AISC (2005) provisions pertaining to additional stiffener requirements for concentrated forces should be considered.

CD6.5.2

This limit state is intended to prevent localized yielding of the web resulting from either high compressive or tensile stress due to a concentrated load or bearing reaction.

A concentrated load acting on a rolled shape or a built-up section is assumed critical at the toe of the fillet located a distance k from the outer face of the flange resisting the concentrated load or bearing reaction, as applicable. For a rolled shape, k is published in the available tables giving dimensions for the shapes. For a built-up section, k may be taken as the distance from the outer face of the flange to the web toe of the web-to-flange fillet weld.

In Eq. D6.5.2-2 for interior loads or interior-pier reactions, the load is assumed to distribute along the web at a slope of 2.5 to 1 and over a distance of $(5k + N)$. An interior concentrated load is defined as a load applied at a distance from the end of the member that is greater than the depth of the steel section d . In Eq. D6.5.2-3 for end loads or end reactions, the load is assumed to distribute along the web at the same slope over a distance of $(2.5k + N)$. These criteria are largely based on the work of Johnston and Kubo (1941) and Graham et al. (1959).

CD6.5.3

This limit state is intended to prevent local instability or crippling of the web resulting from a high compressive stress due to a concentrated load or bearing reaction.

$$R_u \leq \phi_w R_n \quad (\text{D6.5.3-1})$$

in which:

R_n = nominal resistance to the concentrated loading (kip)

- For interior-pier reactions and for concentrated loads applied at a distance from the end of the member that is greater than or equal to $d/2$:

$$R_n = 0.8t_w^2 \left[1 + 3 \left(\frac{N}{d} \right) \left(\frac{t_w}{t_f} \right)^{1.5} \right] \sqrt{\frac{EF_{yw}t_f}{t_w}} \quad (\text{D6.5.3-2})$$

- Otherwise:

- If $N/d \leq 0.2$, then:

$$R_n = 0.4t_w^2 \left[1 + 3 \left(\frac{N}{d} \right) \left(\frac{t_w}{t_f} \right)^{1.5} \right] \sqrt{\frac{EF_{yw}t_f}{t_w}} \quad (\text{D6.5.3-3})$$

- If $N/d > 0.2$, then:

$$R_n = 0.4t_w^2 \left[1 + \left(\frac{4N}{d} - 0.2 \right) \left(\frac{t_w}{t_f} \right)^{1.5} \right] \sqrt{\frac{EF_{yw}t_f}{t_w}} \quad (\text{D6.5.3-4})$$

where:

ϕ_w = resistance factor for web crippling specified in Article 6.5.4.2

t_f = thickness of the flange resisting the concentrated load or bearing reaction (in.)

Eqs. D6.5.3-2 and D6.5.3-3 are based on research by Roberts (1981). Eq. D6.5.3-4 for $N/d > 0.2$ was developed after additional testing by Elgaaly and Salkar (1991) to better represent the effect of longer bearing lengths at the ends of members.

SECTION 7: ALUMINUM STRUCTURES

TABLE OF CONTENTS

7.1—SCOPE..... 7-1

7.2—DEFINITIONS..... 7-1

7.3—NOTATION..... 7-1

7.4—MATERIALS..... 7-3

 7.4.1—General..... 7-3

 7.4.2—Aluminum Sheet, Plate, and Shapes 7-3

 7.4.2.1—Extrusions and Mechanically Fastened Built-Up Members..... 7-3

 7.4.2.2—Welded Built-Up Members..... 7-4

 7.4.3—Material for Pins, Rollers, and Expansion Rockers 7-6

 7.4.4—Fasteners—Rivets and Bolts 7-6

 7.4.5—Weld Metal 7-7

 7.4.6—Aluminum Castings 7-7

 7.4.7—Aluminum Forgings 7-7

7.5—LIMIT STATES..... 7-7

 7.5.1—Service Limit State..... 7-7

 7.5.1.1—Appearance of Buckling 7-7

 7.5.1.2—Effective Width for Calculation of Deflection of Thin Gage Sections 7-8

 7.5.1.3—Web Crippling 7-9

 7.5.1.4—Live Load Deflection 7-9

 7.5.2—Fatigue and Fracture Limit State..... 7-9

 7.5.3—Strength Limit State 7-10

 7.5.4—Resistance Factors..... 7-10

7.6—FATIGUE AND FRACTURE CONSIDERATIONS..... 7-11

 7.6.1—Fatigue 7-11

 7.6.1.1—General 7-11

 7.6.1.2—Load-Induced Fatigue 7-12

 7.6.1.2.1—Application 7-12

 7.6.1.2.2—Design Criteria..... 7-12

 7.6.1.2.3—Detail Categories 7-12

 7.6.1.2.4—Fatigue Resistance 7-16

 7.6.1.3—Distortion-Induced Fatigue..... 7-17

 7.6.1.3.1—Transverse Connection Plates..... 7-18

 7.6.1.3.2—Lateral Connection Plates 7-18

 7.6.2—Fracture 7-18

7.7—DESIGN CONSIDERATIONS 7-18

 7.7.1—Dead Load Camber 7-18

 7.7.2—Welding Requirements 7-18

 7.7.3—Welding Procedures..... 7-18

 7.7.4—Nondestructive Testing 7-19

 7.7.5—Uplift and Slip of Deck Slabs 7-19

 7.7.6—Composite Sections..... 7-19

7.8—GENERAL DIMENSION AND DETAIL REQUIREMENTS	7-19
7.8.1—Effective Length of Span	7-19
7.8.2—Slenderness Ratios for Tension and Compression Members	7-20
7.8.3—Minimum Thickness of Aluminum	7-21
7.8.4—Diaphragms and Cross-Frames	7-21
7.8.5—Lateral Bracing	7-22
7.8.5.1—General	7-22
7.8.5.2—Through-Spans	7-22
7.8.6—Pins and Pin-Connected Elements	7-22
7.9—TENSION MEMBERS	7-23
7.9.1—General	7-23
7.9.2—Tensile Resistance	7-23
7.9.3—Effective Area of Angle and T-Sections	7-23
7.9.4—Net Area	7-24
7.10—COMPRESSION MEMBERS	7-24
7.10.1—General	7-24
7.10.2—Compressive Resistance of Columns	7-26
7.10.3—Compressive Resistance of Components of Columns—Outstanding Flanges and Legs	7-27
7.10.4—Compressive Resistance of Components of Columns, Gross Section—Flat Plates with Both Edges Supported	7-28
7.10.4.1—General	7-28
7.10.4.2—Effect of Local Buckling of Elements on Column Strength	7-29
7.10.5—Compressive Resistance of Components of Columns, Gross Section—Curved Plates Supported on Both Edges, Walls of Round, or Oval Tubes	7-29
7.11—FLEXURAL MEMBERS	7-30
7.11.1—Tensile Resistance of Flexural Member	7-30
7.11.1.1—Net Section	7-30
7.11.1.2—Tension in Extreme Fibers of Beams, Structural Shapes Bent about Strong Axis, Rectangular Tubes	7-30
7.11.1.3—Tension in Extreme Fibers of Beams, Round, or Oval Tubes	7-30
7.11.1.4—Tension in Extreme Fibers of Beams—Shapes Bent about Weak Axis, Rectangular Bars, Plates	7-31
7.11.2—Compressive Resistance of Flexural Members	7-31
7.11.2.1—Compression in Beams, Extreme Fiber, Gross Section, Single-Web Beams Bent about Strong Axis	7-31
7.11.2.2—Compression in Beams, Extreme Fiber, Gross Section, Round or Oval Tubes	7-33
7.11.2.3—Compression in Beams, Extreme Fiber, Gross Section, Solid Rectangular Beams	7-33
7.11.2.4—Compression in Beams, Extreme Fiber, Gross Section, Rectangular Tubes, and Box Sections	7-34
7.11.3—Compressive Resistance of Flexural Members Limited by Plate Slenderness	7-35
7.11.3.1—General	7-35
7.11.3.2—Compression in Components of Beams with Component under Uniform Compression, Gross Section, Outstanding Flanges	7-36
7.11.3.2.1—General	7-36
7.11.3.2.2—Effect of Local Buckling of Elements on Resistance	7-37
7.11.3.3—Compression in Components of Beams with Component under Uniform Compression, Gross Section, Flat Plates with Both Edges Supported	7-37

7.11.3.4—Compression in Components of Beams—Curved Sections	7-38
7.11.3.5—Compression in Components of Beams with Component under Bending in Own Plane, Gross Section, Flat Plates with Compression Edge Free, Tension Edge Supported	7-38
7.11.3.6—Webs of Beams, Gross Section, Flat Plates with Both Edges Supported	7-39
7.11.3.7—Webs of Beams with Longitudinal Stiffener, Both Edges Supported.....	7-40
7.11.4—Shear Resistance	7-40
7.11.4.1—Shear—Unstiffened Flat Webs	7-40
7.11.4.2—Shear in Webs—Stiffened Flat Webs	7-41
7.11.5—Design of Stiffeners	7-42
7.11.5.1—Longitudinal Stiffeners for Webs.....	7-42
7.11.5.2—Transverse Stiffeners for Shear in Webs.....	7-43
7.11.5.3—Stiffeners for Outstanding Flanges	7-44
7.11.5.4—Bearing Stiffeners	7-45
7.12—TORSION	7-45
7.12.1—General.....	7-45
7.12.2—Compression Members Subjected to Torsion	7-45
7.12.2.1—Members with Double-Axis Symmetry	7-46
7.12.2.2—Members with Single-Axis Symmetry.....	7-46
7.12.3—St. Venant Torsion	7-46
7.12.3.1—Open Section.....	7-46
7.12.3.2—Box Section.....	7-47
7.12.4—Warping Torsion	7-47
7.12.4.1—Open Sections	7-47
7.12.4.2—Box Section.....	7-48
7.13—COMBINED FORCE EFFECTS	7-48
7.13.1—Combined Compression and Flexure	7-48
7.13.2—Combined Shear, Compression, and Flexure	7-48
7.13.3—Torsion and Shear in Tubes	7-49
7.13.4—Combined Compression and Flexure—Webs	7-49
7.14—CONNECTIONS AND SPLICES	7-50
7.14.1—General.....	7-50
7.14.2—Bolted Connections.....	7-50
7.14.2.1—Bolts and Nuts	7-50
7.14.2.2—Holes.....	7-51
7.14.2.3—Size of Fasteners	7-51
7.14.2.4—Spacing of Fasteners	7-51
7.14.2.4.1—Minimum Pitch and Clear Distance.....	7-51
7.14.2.4.2—Maximum Pitch for Sealing Fasteners.....	7-51
7.14.2.4.3—Maximum Pitch for Stitch Fasteners	7-52
7.14.2.4.4—Stitch Fasteners at the End of Compression Members	7-52
7.14.2.4.5—End and Edge Distances	7-52
7.14.2.5—Shear Resistance of Fasteners.....	7-52
7.14.2.6—Slip-Critical Connections.....	7-53
7.14.2.7—Bearing Resistance at Fastener Holes	7-53
7.14.2.7.1—General	7-53

7.14.2.7.2—Bearing Resistance at Rivet and Bolt Holes	7-53
7.14.2.7.3—Bearing on Flat Surfaces and Pins	7-53
7.14.2.8—Tension.....	7-53
7.14.3—Block Shear or End Rupture.....	7-54
7.14.4—Splices	7-54
7.14.4.1—General.....	7-54
7.14.4.2—Tension Members.....	7-54
7.14.4.3—Compression Members	7-54
7.14.4.4—Flexural Members	7-54
7.14.4.5—Welding.....	7-55
7.15—PROVISIONS FOR STRUCTURE TYPES	7-55
7.15.1—Floor System	7-55
7.15.2—Lateral Bracing.....	7-55
7.15.3—Beam and Girder Framing.....	7-55
7.15.4—Trusses	7-55
7.15.4.1—General.....	7-55
7.15.4.2—Portal and Sway Bracing.....	7-56
7.15.5—Arches	7-56
7.16—REFERENCES.....	7-57

SECTION 7

ALUMINUM STRUCTURES

7.1—SCOPE

This Section covers the design of aluminum members, splices, and connections for highway bridges, including beam and girder structures, frames, trusses, and arches. Bridges with concrete slabs supported on aluminum floor systems and with orthotropic deck superstructures are included.

7.2—DEFINITIONS

The provisions of Article 6.2 shall apply.

Plate—A flat rolled product whose thickness equals or exceeds 0.25 in.

Sheet—A flat rolled product whose thickness is between 0.006 in. and 0.25 in.

7.3—NOTATION

A	=	area (in. ²) (7.4.2.2)
A_b	=	nominal bolt area (in. ²) (7.14.2.8)
A_c	=	area of compression element (in. ²), consisting of compression flange, plus one-third of the area of web between compression flange and neutral axis (in. ²) (7.11.2.1)
$(ADTT)_{SL}$	=	single-lane average daily truck traffic (7.6.1.2.4)
A_ℓ	=	gross area of cross-section of longitudinal stiffener (in. ²) (7.11.5.1)
A_w	=	area of a cross-section lying within 1.0 in. of a weld (in. ²) (7.4.2.2)
a_1	=	shorter dimension of rectangular panel (in.) (7.11.4.2)
a_2	=	longer dimension of rectangular panel (in.) (7.11.4.2)
a_e	=	equivalent width of rectangular panel (in.) (7.11.4.2)
B, D, C	=	buckling formula parameters, with following subscript: (ksi, ksi, dim.) (7.10.1) c —compression in columns p —compression in flat plates t —compression in round tubes tb —bending in round tubes b —bending in rectangular bars s —shear in flat plates
b	=	width of element; width of compression flange; width of rectangular plate element (in.) (7.5.1.2) (7.11.3.1) (7.12.3.1)
b_e	=	effective width of a thin element (in.) (7.5.1.2)
b_L	=	clear width of lip (in.) (7.11.5.3)
C	=	warping constant (in. ⁶) (7.12.2.1) (7.12.4.1)
C_1, C_2	=	fatigue resistance constants (7.6.1.2.4)
c	=	distance from neutral axis to extreme fiber (in.) (7.4.2.2)
d	=	depth of section or beam (in.) (C7.11.2.1)
E	=	compressive modulus of elasticity (ksi) (7.4.2)
F_a	=	factored resistance in terms of stress, F_r , for components subject to compression only (ksi) (7.13.1) (7.13.4)
F_b	=	factored flexural resistance in terms of stress, F_r , for components subjected to flexure only (ksi) (7.13.1) (7.13.4)
F_{bf}	=	factored resistance in terms of stress for the flange proper, taken as F_r (ksi) (7.11.3.1)
F_{bh}	=	factored resistance in terms of stress for webs of flexural members (ksi) (7.11.3.1)
F_{bu}	=	ultimate bearing strength (ksi) (7.4.2.1)
F_{by}	=	bearing yield strength (ksi) (7.4.2.1)
F_{cr}	=	element buckling stress (ksi) (7.5.1.2)
F_{cy}	=	compressive yield strength (ksi) (7.4.2.1)
F_n	=	limiting stress for cross-section 1.0 in. or more from weld, ksi, taken from Table 7.4.2.1-1 (7.4.2.2)

F_{pw}	=	limiting stress on cross-section, part of whose area lies within 1.0-in. of a weld (ksi) (7.4.2.2)
F_r	=	factored resistance (7.5.3)
F_{rb}	=	factored resistance in terms of compressive bending stress in beam flange (ksi) (7.11.3.2.1)
F_s	=	factored resistance in terms of stress for members subjected only to torsion or shear (ksi) (7.13.2)
F_{su}	=	ultimate shear strength (ksi) (7.4.2.1)
F_{sy}	=	shear yield strength (ksi) (7.4.2.1)
F_{tu}	=	ultimate tensile strength (ksi) (7.4.2.1)
F_{ty}	=	tensile yield strength (ksi) (7.4.2.1) (7.4.2.2)
F_w	=	limiting stress on cross-section if entire area were to lie within 1.0 in. of a weld (ksi) (7.4.2.2)
f	=	calculated stress (ksi) (7.11.5.1)
f_a	=	factored average compressive stress on cross-section of member produced by axial compressive load (ksi) (7.5.1.2) (7.13.1) (7.13.2)
f_b	=	factored maximum compressive bending stress caused by transverse loads or end moments (ksi) (7.13.1) (7.13.4)
f_s	=	factored shear stress caused by either torsion or transverse shear (ksi) (7.13.2)
f_{2b}, f_{2s}	=	factored end stresses (ksi) (7.13.1)
G	=	shear modulus of elasticity (ksi); grip of rivet or bolt (in.) (7.12.2.1) (7.14.1)
g	=	spacing of rivet or bolt holes perpendicular to direction of load; gage between fasteners (in.) (7.9.4) (7.14.2.4.2) (7.14.2.4.3)
h	=	depth of shear web (in.) (7.11.3.1) (7.11.5.4) (7.12.4.1)
I_b	=	required moment of inertia of bearing stiffener (in. ⁴) (7.11.5.4)
I_ℓ	=	moment of inertia of longitudinal stiffener (in. ⁴) (7.11.5.1)
I_p	=	polar moment of inertia referred to the shear center (in. ⁴) (7.12.2.1)
I_s	=	moment of inertia of transverse stiffener (in. ⁴) (7.11.5.2)
I_y	=	moment of inertia of a beam about axis parallel to web (in. ⁴) (C7.11.2.1)
I_{yc}	=	moment of inertia of compression element about axis parallel to vertical web (in. ⁴) (7.11.2.1)
I_1, I_2	=	moment of inertia of the upper and lower flange, respectively, about the y-axis taken as the axis of symmetry (in. ⁴) (7.12.4.1)
J	=	torsional constant (in. ⁴) (C7.11.2.1)
K	=	effective length factor (7.10.2)
KL/r	=	slenderness ratio for columns (7.8.2)
k_b	=	lateral buckling coefficient (C7.11.2.1)
k_c	=	coefficient for compression members (7.10.1)
k_t	=	coefficient for tension members (7.10.1)
k_1	=	coefficient for determining slenderness limit S_2 of sections for which the limit state compressive stress is based on crippling strength (7.10.1)
k_2	=	coefficient for determining limit state compressive stress in sections with slenderness ratio above S_2 for which the limit state compressive stress is based on crippling strength (7.10.1)
L	=	length of compression member between points of lateral support, or twice the length of a cantilever column, except where analysis shows that a shorter length should be used, length of plates (in.); unsupported plate length (in.) (7.8.2) (7.8.5.2)
L_b	=	length of beam between points at which the compression flange is supported against lateral movement, or length of cantilever beam from free end to point at which the compression flange is supported against lateral movement (in.) (C7.11.2.1)
L_t	=	length of tube between circumferential stiffeners (in.) (7.13.3)
M_1, M_2	=	bending moments at two ends of a beam (kip-in.) (C7.11.2.1)
N	=	length of bearing at reaction or concentrated load (in.); (365) (75) n ($ADTT$) _{SL} (7.5.1.3) (7.6.1.2.4)
n	=	cycles per truck passage; 1.0 for curved walls or round tubular members, or 2.0 for webs of rectilinear shapes and plates of built-up beams (7.6.1.2.4) (7.13.2)
P	=	factored reaction force (kip) (7.11.5.4)
P_c	=	reaction or concentrated load per web (kip) (7.5.1.3)
p	=	pitch of fasteners (in.) (7.14.2.4)
R	=	transition radius, the radius of an attachment of the weld detail (in.); outside radius of round tubular column or maximum outside radius of oval tubular column (in.) (7.6.1.2.3) (7.13.3)
R_b	=	midthickness radius of curvature of curved plates and tubular beam elements (in.) (7.11.2.2)
r	=	bend radius at juncture of flange and web areas to the inside surface of bend (in.) (7.5.1.3)
r_L	=	radius of gyration of lip or bulb about face of flange from which lip projects (in.) (7.11.5.3)

r_y	=	radius of gyration of a beam, about axis parallel to web, for beams that are unsymmetrical about the horizontal axis, r_y should be calculated as though both flanges were the same as the compression flange (in.) (7.11.2.1)
S_c	=	section modulus of a beam, compression side (in. ³) (C7.11.2.1)
S_2	=	slenderness limits (7.10.2) (7.10.3)
SR	=	stress ratio, the ratio of minimum stress to maximum stress (7.6.1.2.3)
s	=	spacing of transverse stiffeners, clear distance between stiffeners for stiffeners consisting of a pair of members, one on each side of the web, center-to-center distance between stiffeners consisting of a member on one side of the web only (in.) (7.11.5.1)
t	=	thickness of flange, plate, web or tube (in.). For tapered flanges, t is the average thickness (in.) (7.5.1.3)
V	=	shear force on web at stiffener location (kip) (7.11.5.2)
α	=	factor equal to 1.0 for a stiffener consisting of equal members on both sides of the web and equal to 3.5 for a stiffener consisting of a member on one side only (7.11.5.1)
β	=	spring constant, transverse force in kip applied to a 1.0-in. length of the member at the compression flange to cause a 1.0-in. deflection of the flange (7.11.2.1)
Δf	=	stress range due to the passage of the fatigue truck (ksi) (7.6.1.2.2)
$(\Delta F)_N$	=	nominal fatigue resistance (ksi) (7.6.1.2.2)
$(\Delta F)_{th}$	=	constant amplitude fatigue threshold (ksi) (7.6.1.2.4)
θ	=	angle $\leq 90^\circ$ between plane of web and plane of bearing surface (7.5.1.3)
ϕ	=	resistance factor (7.5.3) (7.5.4)
λ	=	slenderness parameter (7.10.2)

7.4—MATERIALS

7.4.1—General

These Specifications shall apply to aluminum alloys and tempers listed herein.

Other aluminum alloys and tempers may be used, however, their engineering properties, including strengths, yield strength and workability shall be established by tests in accordance with ASTM B557 and ASTM E9.

7.4.2—Aluminum Sheet, Plate, and Shapes

The compressive modulus of elasticity, E , shall be taken as 10,100 ksi for Alloys 6061-T6, 6061-T651 and 6063-T6. For all other alloys specified in Table 7.4.2.1-1, E shall be taken as 10,400 ksi.

The coefficient of linear expansion shall be taken as 0.000013 in./in./°F.

7.4.2.1—Extrusions and Mechanically Fastened Built-Up Members

Except as permitted herein, the properties of aluminum sheet, plate, and shapes shall be taken as specified in Table 7.4.2.1-1.

F_{tu} and F_{ty} for nonwelded material shall be the minimum specified values; otherwise, strength properties for nonwelded material shall be the corresponding expected minimum values.

C7.4.1

Most alloys of interest in highway construction will have properties and workability available in The Aluminum Association's *Specifications for Aluminum Structures*.

C7.4.2

The current specification allows the use of any corrosion-resistant alloys and tempers with established minimum mechanical properties and refers to the *Specifications for Aluminum Structures* as a source for this information. Alloy 6063 is commonly used in the T6 temper, is highly corrosion resistant and easily welded, and is listed in the *Specifications for Aluminum Structures*.

C7.4.2.1

F_{tu} and F_{ty} are measured for each lot of material made at the plants of the various aluminum producers. This large database is used to determine statistically-based "minimum properties." "Expected minimum values" for the other properties are estimated from an analysis of a much smaller database, utilizing the variability obtained from the tensile test data.

Exceptions are as follows:

- Values for other alloys and tempers, and Alloys 5456-H116 and 5083-H321 in thicknesses other than those listed in Table 7.4.2.1-1, may be taken from the latest edition of *Specifications for Aluminum Structures*.
- Plate values listed for Alloy 6061-T6 shall also apply to sheet. Sheet and plate in the thickness range 0.021 to 0.499 in. shall have a minimum elongation of ten percent; other thickness ranges have the same strength values, but a lower minimum elongation.
- Values listed for shapes of Alloys 6061-T651 and 6061-T6 shall be taken to apply to ASTM B308 Standard Structural Shapes and ASTM B429 Extruded Structural Pipe and Tube.

The values in Table 7.4.2.1-1 are substituted in the appropriate criteria in Articles 7.9 through 7.13 to develop component resistance. For welded construction, the additional provisions of Article 7.4.2.2 also apply.

Minimum elongation of Alloy 6061-T6 is dependent on sheet thickness, with the value decreasing for both thinner and thicker sheet. Values for other thickness sheet can be found in the Aluminum Association's *Aluminum Standards and Data*.

Table 7.4.2.1-1—Minimum Nonwelded Material Properties for Aluminum Sheets, Plates, and Shapes

ASTM Designation		B209	B209	B209 and B221		B209	B221
Alloy Number		5086-H116	5456-H116	6061-T651 and 6061-T6		5083-H321	6063-T6
Product		Plate	Sheet and Plate	Shapes	Sheet and Plate	Sheet and Plate	Shapes
Thickness (in.)		0.250 to 2.000	0.188 to 1.25	–All–	0.010 to 4.00	0.188 to 1.500	–All–
Tensile Strength (ksi)	F_{tu}	40.0	46.0	38.0	42.0	44.0	30
Tensile Yield Strength (ksi)	F_{ty}	28.0	33.0	35.0	35.0	31.0	25
Compressive Yield Strength (ksi)	F_{cy}	26.0	27.0	35.0	35.0	26.0	25
Shear Strength (ksi)	F_{su}	24.0	27.0	24.0	27.0	26.0	19
Shear Yield Strength (ksi)	F_{sy}	16.0	19.0	20.0	20.0	18.0	14
Bearing Strength (ksi)	F_{bu}	78.0	87.0	80.0	88.0	84.0	63
Bearing Yield Strength (ksi)	F_{by}	48.0	56.0	56.0	58.0	53.0	40

7.4.2.2—Welded Built-Up Members

If less than 15 percent of the area of a given cross-section lies within 1.0-in. of a weld, regardless of material thickness, the effect of welding may be neglected, and the limiting stresses for use in Articles 7.9 through 7.13 shall be taken as specified in Table 7.4.2.1-1.

If the area of a cross-section lying within 1.0 in. of a weld, A_w , is not less than 15 percent of the net area, A , the limiting stress for use in Articles 7.9 through 7.13 shall be taken as:

$$F_{pw} = F_n - \frac{A_w}{A} (F_n - F_w) \quad (7.4.2.2-1)$$

where:

F_{pw} = effective nominal limiting stress on cross-section, part of whose area lies within 1.0 in. of a weld (ksi)

F_n = limiting stress for cross-section 1.0 in. or more from weld specified in Table 7.4.2.1-1 (ksi)

F_w = limiting stress on cross-section if entire area were to lie within 1.0 in. of a weld, specified in Table 7.4.2.2-1 (ksi)

A_w = area of a cross-section lying within 1.0 in. of a weld (in.²)

A = net area of cross-section of a tension member or tension flange of a beam, or gross area of cross-section of a compression member or compression flange of a beam; in calculating the net area, A , a beam flange shall be considered to consist of that portion of the member further than $2c/3$ from the neutral axis (in.²)

c = distance from neutral axis to the extreme fiber (in.)

The following exceptions may be permitted:

- All of the exceptions to Table 7.4.2.1-1 given in Article 7.4.2.1 apply to Table 7.4.2.2-1.
- Plate values of F_{ty} , F_{cys} , and F_{sy} listed for Alloys 6061-T651 and 6061-T6 shall be taken to apply to material of any thickness when welded with 5183, 5356, or 5556 filler wire; they also apply to material where thickness does not exceed 0.375 in. when welded with 4043, 5154, or 5554 filler alloys. The strength values for material thicker than 0.375 in. that is welded with the latter filler alloys shall be taken as 15.0 ksi for tensile and compressive yield strength and 9.0 ksi for shear yield strength. F_{ty} and F_{cy} for welded material shall correspond to the 0.2 percent offset value in a 10.0-in. gage length across a butt weld.

Table 7.4.2.2-1—Minimum Material Properties near Welds for Aluminum Sheets, Plates, and Shapes

ASTM Designation		B209	B209	B209 and B221	B209	B221
Alloy Number		5086-H116	5456-H116	6061-T651 and 6061-T6	5083-H321	6063-T6
Product		Plate	Sheet and Plate	Shapes and Plate	Sheet and Plate	Shapes
Thickness (in.)		0.250 to 2.000	0.188 to 1.25	—All—	0.188 to 1.500	—All—
Tensile Strength	F_{tu} (ksi)	35.0	42.0	24.0	40.0	17
Tensile Yield Strength	F_{ty} (ksi)	19.0	26.0	20.0	24.0	11
Compressive Yield Strength	F_{cy} (ksi)	19.0	24.0	20.0	24.0	11
Shear Strength	F_{su} (ksi)	21.0	25.0	15.0	24.0	11
Shear Yield Strength	F_{sy} (ksi)	11.0	15.0	12.0	14.0	6.5
Bearing Strength	F_{bu} (ksi)	70.0	84.0	50.0	80.0	34
Bearing Yield Strength	F_{by} (ksi)	28.0	38.0	30.0	36.0	22

7.4.3—Material for Pins, Rollers, and Expansion Rockers

Material for pins, rollers, and expansion rockers shall be aluminum Alloy 6061-T6 or coated steel conforming to Article 6.4.2.

7.4.4—Fasteners—Rivets and Bolts

Fasteners shall conform to one of the following:

- Power driven aluminum rivets that are made of ASTM B316, Alloy 6061-T6 Material and that conform to the requirements of MIL-R-1150F; or
- Coated AASHTO M 164 (ASTM A325) high-strength steel bolts or ASTM F593, Alloy Groups 1, 2, or 3 stainless steel bolts; or
- Aluminum, stainless steel, or coated steel lockbolts conforming to the requirements of MIL-P-23469; or
- Coated steel blind fasteners.

Strength of Alloy 6061-T6 rivets shall be as specified in Table 7.4.4-1.

Table 7.4.4-1—Strength of Aluminum Rivets

Alloy and Temper	Tensile Strength (ksi)	Tensile Yield Strength (ksi)	Shear Strength (ksi)
6061-T6	42.0	35.0	25.0

C7.4.4

Various proprietary steel blind fasteners are available with strengths that exceed those of aluminum rivets. These blind fasteners are especially useful because they can be installed without access to both sides of the work. They have been widely used on structures subject to fatigue and vibration, such as aircraft and transportation vehicles.

7.4.5—Weld Metal

Weld metal shall conform to the requirements of ANSI/AWS D1.2, current issue.

For welded sheet and plate material for Alloy 5456-H116 and Alloy 5083-H321, minimum material properties shall be taken from Table 7.4.2.2-1.

F_u shall be taken as the ASME weld qualification test value; other properties shall correspond.

7.4.6—Aluminum Castings

Permanent aluminum mold castings shall conform to the requirements of ASTM B108, Alloy A444.0-T4. The tensile strength of Alloy A444.0-T4 shall be 20.0 ksi.

7.4.7—Aluminum Forgings

Aluminum forgings and forging stock shall conform to the requirements of ASTM B247, Alloy 6061-T6. Tensile and yield strengths, and elongations for this alloy shall be taken as specified in Table 7.4.7-1.

Compressive yield strength, shear strength, shear yield strength, and bearing yield strength values shall be taken as specified in Table 7.4.2.1-1.

The provisions of Article 7.4.5 shall apply for welded values.

Table 7.4.7-1—Minimum Material Properties of Aluminum Alloy 6061-T6, Forgings, Specimen Axis Parallel to Grain Flow

Specified Thickness	Tensile Strength (ksi)	Tensile Yield Strength (ksi)	Elongation in 2.0 in. or 4 × diameter, %	
			Forgings	Separate Test Coupon
To 4.0 in., inclusive	38.0	35.0	7.0	10.0

7.5—LIMIT STATES**7.5.1—Service Limit State****7.5.1.1—Appearance of Buckling**

In applications where any appearance of buckling cannot be tolerated, the stresses for thin sections shall not exceed the values specified in Table 7.5.1.1-1.

Table 7.5.1.1-1—Element Buckling Stresses

Article	Buckling Stress, F_{cr}
7.10.4—Compressive Resistance of Components of Columns, Gross Section—Flat Plates with Both Edges Supported	$\frac{\pi^2 E}{\left(\frac{1.6b}{t}\right)^2}$
7.11.3.3—Compression in Components of Beams with Component under Uniform Compression, Gross Section, Flat Plates with Both Edges Supported	$\frac{\pi^2 E}{\left(\frac{0.67h}{t}\right)^2}$
7.11.3.6—Webs of Beams, Gross Section—Flat Plates with Both Edges Supported	$\frac{\pi^2 E}{\left(\frac{0.29h}{t}\right)^2}$
7.11.3.7—Webs of Beams with Longitudinal Stiffener, Both Edges Supported	$\frac{\pi^2 E}{\left(\frac{5.1b}{t}\right)^2}$
7.11.3.2—Compression in Components of Beams with Component Under Uniform Compression, Gross Section—Outstanding Flanges	$\frac{\pi^2 E}{\left(\frac{3.5b}{t}\right)^2}$
7.11.3.5—Compression in Components of Beams with Component Under Bending in Own Plane, Gross Section, Flat Plates with Compression Edge Free, Tension Edge Supported	

7.5.1.2—Effective Width for Calculation of Deflection of Thin Gage Sections

The effective width, b_e , of a thin element subjected to direct compression stresses may be taken as:

$$\text{If } f_a \leq \phi F_{cr}, \text{ then } b_e = b \quad (7.5.1.2-1)$$

$$\text{If } f_a > \phi F_{cr}, \text{ then } b_e = b \frac{\sqrt{\phi F_{cr}}}{f_a} \quad (7.5.1.2-2)$$

where:

b_e = effective width of flat plate element to be used in deflection calculations (in.)

b = clear width of element (in.)

F_{cr} = buckling stress for element as specified in Article 7.5.1.1 (ksi)

f_a = compressive stress (ksi)

Eq. 7.5.1.2-2 may be used to calculate the effective width on the compression side of a web in flexure, in which case the compressive flexural stress due to the applied loads, f_b , replaces f_a .

C7.5.1.2

Where deflection at the service limit state is critical, the effective width concept may be used to determine an effective section to be used in deflection calculations.

7.5.1.3—Web Crippling

The compressive web resistance at points of interior reactions and concentrated loads for flat webs shall be taken as:

$$P_c = \frac{\phi t^2 (N + 5.4) \sin \theta (0.92 F_{cy} + 0.04 \sqrt{E F_{cy}})}{2 [0.4 + r(1 - \cos \theta)]} \quad (7.5.1.3-1)$$

The compressive web resistance at points of end reactions shall be taken as:

$$P_c = \frac{0.6 \phi t^2 (N + 1.3) \sin \theta (0.92 F_{cy} + 0.04 \sqrt{E F_{cy}})}{[0.4 + r(1 - \cos \theta)]} \quad (7.5.1.3-2)$$

where:

- E = compressive modulus of elasticity (ksi)
- F_{cy} = specified compressive yield strength of sheet (ksi)
- N = length of bearing at reaction or concentrated load (in.)
- P_c = reaction or concentrated load (kip)
- r = bend radius at juncture of flange and web measured to the inside surface of bend (in.); taken to be equal to zero for filleted web-flange junctures
- t = web thickness (in.)
- ϕ = resistance factor as specified in Table 7.5.4-1
- θ = angle between plane of web and plane of bearing surface (degrees)

7.5.1.4—Live Load Deflection

The provisions of Article 2.5.2.6 should be considered.

7.5.2—Fatigue and Fracture Limit State

Components and details shall be investigated for fatigue as specified in Article 7.6.

The fatigue load combination specified in Table 3.4.1-1 and the fatigue live load specified in Article 3.6.1.4 shall apply.

7.5.3—Strength Limit State

Members and connections shall be designed for all applicable strength load combinations specified in Table 3.4.1-1.

The factored resistance, F_r , of members, given in terms of stress, shall be taken as:

$$F_r = \phi F_n \quad (7.5.3-1)$$

where:

ϕ = resistance factor as applicable to yield or ultimate stress, specified in Table 7.5.4-1

F_n = nominal yield, ultimate stress, or buckling stress specified in Articles 7.9, 7.10, 7.11, 7.12, 7.13, and 7.14 as appropriate (ksi)

7.5.4—Resistance Factors

Resistance factors shall be taken as specified in Table 7.5.4-1.

Table 7.5.4-1—Resistance Factors

Force Effect		ϕ_v	ϕ_u	ϕ_c	ϕ_s	ϕ_b
Web Crippling		—	—	0.80	—	—
Tensile Resistance		0.90	0.75	—	—	—
Column Capacity:		for $\lambda < 1.5$, $\phi_c = 0.94 - 0.19\lambda \leq 0.90$ for $\lambda \geq 1.5$, $\phi_c = 0.52 + 0.09\lambda \leq 0.90$			0.90	—
Compression in Components of Columns—Outstanding Flanges and Legs		—	—	0.80	0.90	—
Compression in Components of Columns, Gross Section—Flat Plates with Both Edges Supported		—	—	0.80	0.90	—
Compression in Components of Columns, Gross Section—Curved Plates Supported on Both Edges, Walls of Round or Oval Tubes		—	—	0.75	0.90	—
Tension in Extreme Fibers of Beams	Structural Shapes Bent about Strong Axis	0.90	0.80	—	—	—
	Rectangular Tubes	0.90	0.85	—	—	—
Tension in Extreme Fibers of Beams—Round or Oval Tubes—Bolts		0.85	0.75	—	—	—
Tension in Extreme Fibers of Beams—Shapes Bent about Weak Axis, Rectangular Bars, Plates		0.85	0.75	—	—	—
Compression in Beams, Extreme Fiber, Gross Section—Single-Web Beams Bent about Strong Axis		—	—	—	0.90	0.80
Compression in Beams, Extreme Fiber, Gross Section—Round or Oval Tubes		—	—	—	0.85	0.75
Compression in Beams, Extreme Fiber, Gross Section—Solid Rectangular Beams		—	—	—	0.85	0.85
Compression in Beams, Extreme Fiber, Gross Section—Rectangular Tubes and Box Sections		—	—	—	0.90	0.80
Compression in Components of Beams (Component under Uniform Compression), Gross Section—Outstanding Flanges		—	—	0.80	0.90	—
Compression in Components of Beams (Component under Uniform Compression), Gross Section—Flat Plates with Both Edges Supported		—	—	0.80	0.90	—
Compression in Components of Beams—Curved Sections		—	—	0.75	0.85	—
Compression in Components of Beams (Component under Bending in Own Plane), Gross Section—Flat Plates with Compression Edge Free, Tension Edge Supported		—	—	0.80	0.85	—
Compression in Components of Beams (Component Under Bending in Own Plane), Gross Section—Flat Plates with Both Edges Supported		—	—	0.80	0.85	—
Compression in Components of Beams (Component Under Bending in Own Plane), Gross Section—Flat Plates with Horizontal Stiffener, Both Edges Supported		—	—	0.80	0.85	—
Shear—Unstiffened Flat Webs		—	—	0.80	0.90	—
Shear—Stiffened Flat Webs		—	—	0.80	0.90	—
Shear—Transverse Stiffeners		$\phi = 0.90$				
Bearing Stiffeners		$\phi = 0.90$				

7.6—FATIGUE AND FRACTURE CONSIDERATIONS

7.6.1—Fatigue

7.6.1.1—General

Fatigue shall be categorized as load-induced fatigue or as distortion-induced fatigue.

C7.6.1.1

In the 1996 AASHTO Standard Specifications, the provisions explicitly relating to fatigue dealt only with load-induced fatigue.

7.6.1.2—Load-Induced Fatigue

7.6.1.2.1—Application

The force effect considered for the fatigue design of an aluminum bridge detail shall be the live load stress range.

Residual stresses shall not be included in the stress range.

These provisions shall only be applied to details subject to a net applied tensile stress. In regions where the permanent loads produce compression, fatigue shall be considered only if this compressive stress is less than twice the maximum tensile live load stress resulting from the fatigue load combination as specified in Table 3.4.1-1.

7.6.1.2.2—Design Criteria

For load-induced fatigue considerations, each detail shall satisfy:

$$\gamma(\Delta f) \leq (\Delta F)_N \quad (7.6.1.2.2-1)$$

where:

γ = load factor specified in Table 3.4.1-1 for the fatigue load combination

Δf = the force effect, stress range due to the passage of the fatigue load as specified in Article 3.6.1.4 (ksi)

$(\Delta F)_N$ = the nominal fatigue resistance as specified in Article 7.6.1.2.4 (ksi)

7.6.1.2.3—Detail Categories

Components and details with fatigue resistance less than or equal to Detail Category C shall be designed to satisfy the requirements of their respective detail categories, as summarized in Table 7.6.1.2.3-1 and shown in Figure 7.6.1.2.3-1. For aluminum orthotropic decks, the details in Table 6.6.1.2.3-1 should also be considered.

C7.6.1.2.1

Commentary of Article 6.6.1.2.1 is also applicable to aluminum bridges.

C7.6.1.2.2

Rewriting Eq. 7.6.1.2.2-1 in terms of fatigue load and resistance parameters yields:

$$\gamma(\Delta f) \leq \eta\phi(\Delta F)_N \quad (C7.6.1.2.2-1)$$

but for the fatigue limit state,

$\eta = 1.0$,

$\phi = 1.0$.

Table 7.6.1.2.3-1—Detail Categories for Fatigue

Construction	Detail	Detail Category	Illustrative Example Numbers
Plain Members	Base metal with rolled or cleaned surfaces	A	1, 2
Built-Up Members	Base metal and weld metal in components, without attachments, connected by: <ul style="list-style-type: none"> • Continuous full-penetration groove welds, or • Continuous partial-penetration groove welds parallel to the direction of applied stress, or • Continuous fillet welds parallel to the direction of applied stress 	B	3, 4, 5
	Base metal at ends of partial-length cover plates with or without end welds	E	5
Mechanically Fastened Connections	Base metal at net section of joints: <ul style="list-style-type: none"> • That do not include out-of-plane bending in the connected material, where: <ul style="list-style-type: none"> ○ stress ratio < 0.0 ○ $0.0 \leq$ stress ratio < 0.5 ○ stress ratio \geq 0.5 • That include out-of-plane bending in the connected material 	C	7
		D	
Fillet-Welded Connections with Welds Normal to the Direction of Stress	Base metal: <ul style="list-style-type: none"> • At the toe of transverse stiffener-to-flange or transverse stiffener-to-web connections • At the junction of axially loaded members with fillet-welded end connections, with the welds positioned about the member's axis to balance weld stresses 	E	8
		C	6
Fillet-Welded Connections with Welds Normal or Parallel to the Direction of Stress	Shear stress on the weld throat	E	15, 17
		F	5, 15, 18

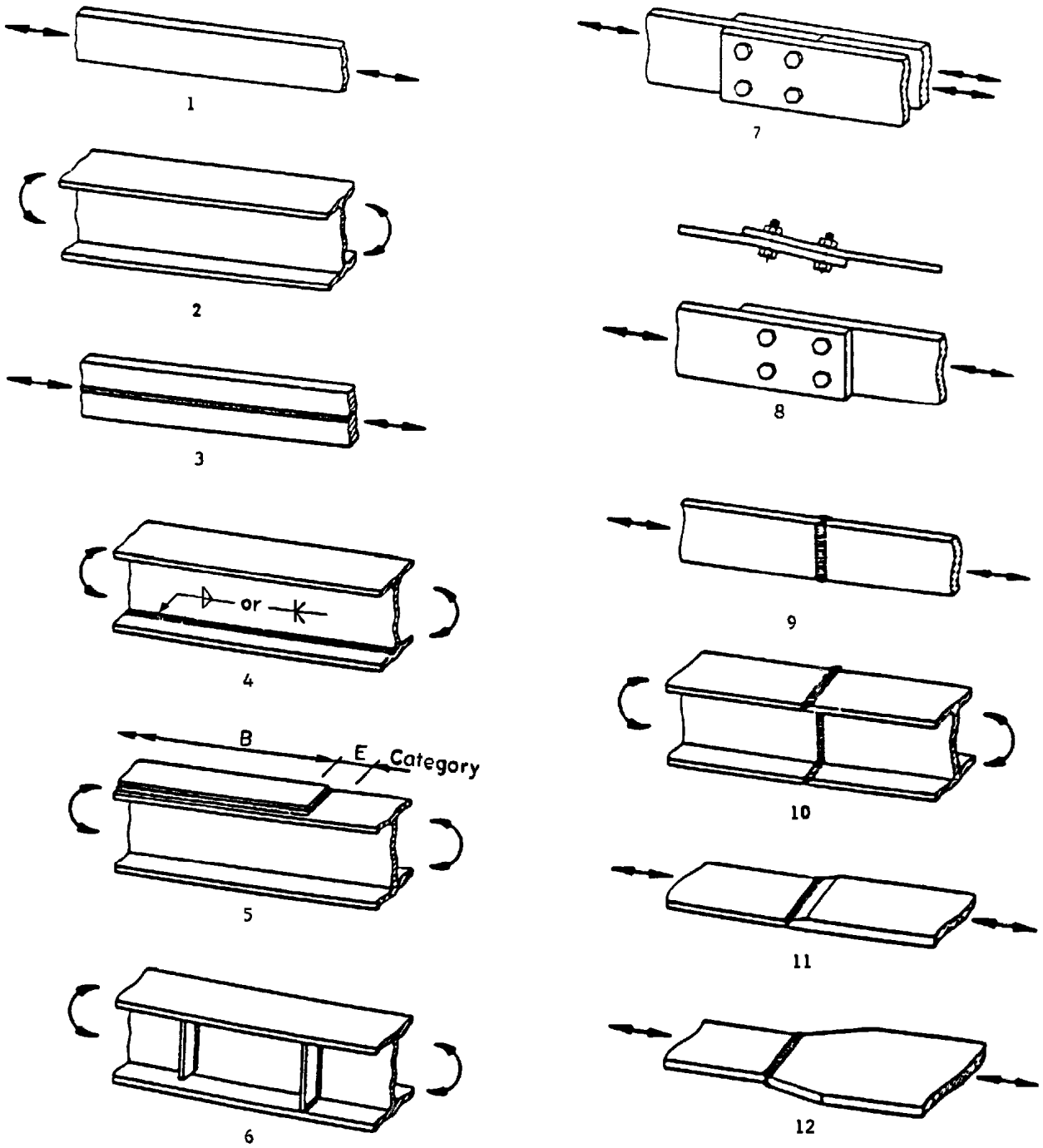

Figure 7.6.1.2.3-1—Illustrative Examples

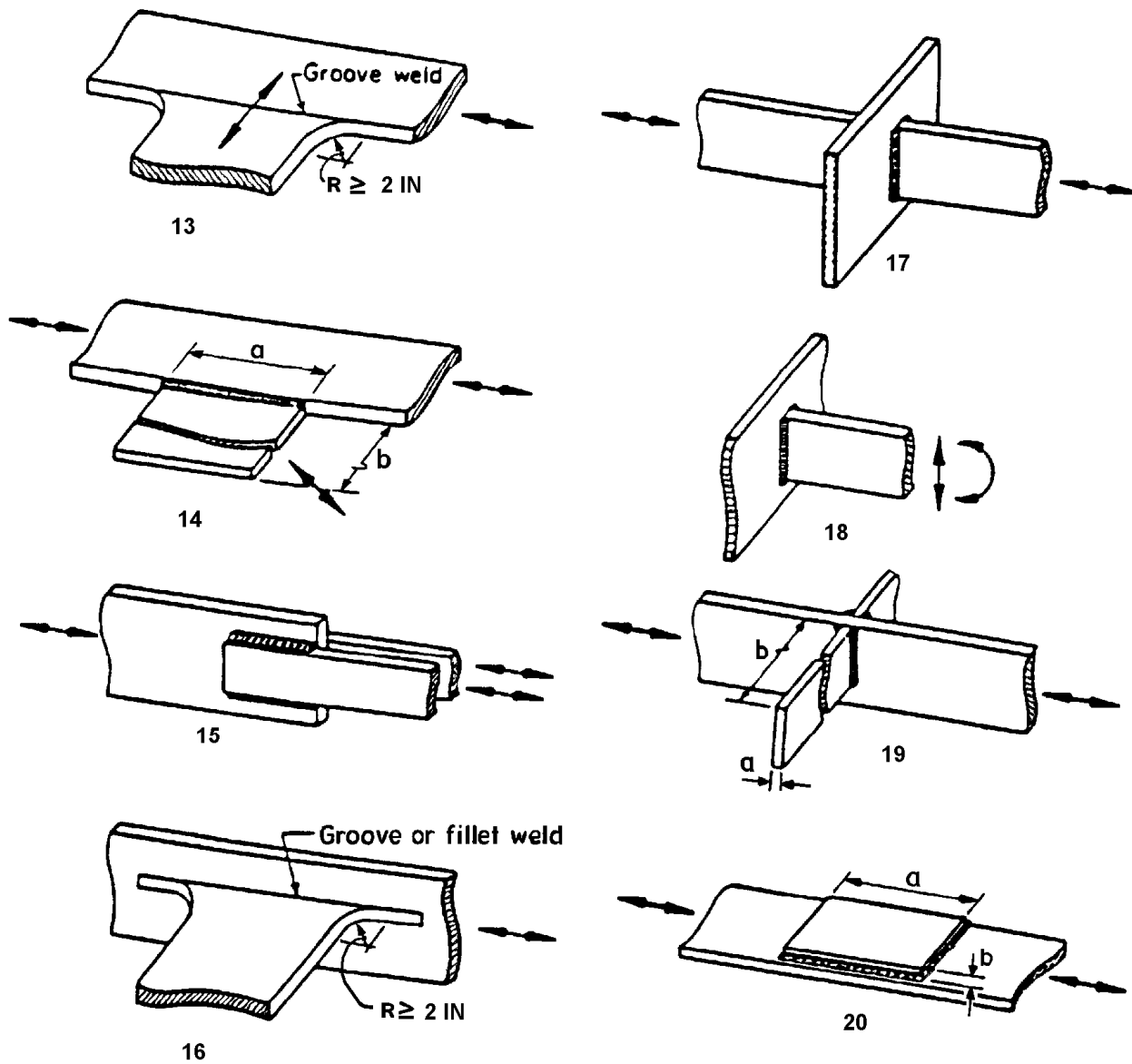

Figure 7.6.1.2.3-1— Illustrative Examples (continued)

7.6.1.2.4—Fatigue Resistance

Nominal fatigue resistance shall be taken as:

$$(\Delta F)_N = \left(\frac{C_1}{N} \right)^{C_2} \geq \frac{1}{2} (\Delta F)_{TH} \tag{7.6.1.2.4-1}$$

in which:

$$N = (365)(75)n(ADTT)SL \tag{7.6.1.2.4-2}$$

where:

C_1, C_2 = constant specified in Table 7.6.1.2.4-1

n = number of stress range cycles per truck passage taken from Table 7.6.1.2.4-2

C7.6.1.2.4

The requirement on higher traffic volume bridges that the maximum stress experienced by a detail be less than the constant amplitude fatigue threshold provides a theoretically infinite fatigue life. The maximum stress range is assumed to be twice the live load stress range due to the passage of the fatigue load, factored in accordance with the load factor in Table 3.4.1-1 for the fatigue load combination.

In the 1996 AASHTO *Standard Specifications*, the constant amplitude fatigue threshold was termed the allowable fatigue stress range for more than 2 million cycles on a redundant load path structure.

The design life has been considered to be 75 yr in the overall development of the Specifications. If a design life other than 75 yr is sought, a number other than 75 may be inserted in the equation for N .

$(ADTT)_{SL}$ = single lane $ADTT$ as specified in Article 3.6.1.4

$(\Delta F)_{TH}$ = constant-amplitude fatigue threshold specified in Table 7.6.1.2.4-3 (ksi)

Table 7.6.1.2.4-1—Detail Category Constants

Detail Category	$C_1 \times 10^8$	C_2
A	100,000.0	0.155
B	520.0	0.211
C	36.0	0.237
D	8.4	0.249
E	1.2	0.284
F	0.46	0.292

Table 7.6.1.2.4-2—Load Cycles, n , per Truck Passage

Longitudinal Members	Span Length	
	>40.0 ft	≤40.0 ft
Simple Span Girders	1.0	2.0
Continuous Girders	5.0	
	1) near interior support	2.0
2) elsewhere	1.0	2.0
Cantilever Girders	5.0	
Trusses	1.0	
Transverse Members	Spacing	
	>20.0 ft	≤20.0 ft
	1.0	2.0

Table 7.6.1.2.4-3—Constant Amplitude Fatigue Thresholds

Detail Category	Threshold (ksi)
A	9.5
B	6.0
C	4.0
D	3.0
E	2.0
F	1.6

7.6.1.3—Distortion-Induced Fatigue

Load paths sufficient to transmit all intended and unintended forces shall be provided by connecting transverse members, either primary or secondary members, to all the components that comprise the longitudinal cross-section of the member. The load paths shall be provided by attaching the various components through either welding or bolting.

C7.6.1.3

Distortion-induced stresses are difficult to quantify by routine calculations. The best approach, therefore, is to preclude the development of such stresses by appropriate detailing.

7.6.1.3.1—Transverse Connection Plates

The provisions of Article 6.6.1.3.1 shall apply.

7.6.1.3.2—Lateral Connection Plates

The provisions of Article 6.6.1.3.2 shall apply.

7.6.2—Fracture

Mandatory toughness requirements specified herein shall apply only to fracture-critical members.

Fracture-critical members shall be identified in the contract documents.

Fracture-critical members may be evaluated by *R* curve analysis complying with ASTM E561 or evidence of material ductility inferred from reduction of area during tensile tests.

7.7—DESIGN CONSIDERATIONS

7.7.1—Dead Load Camber

Provisions of Article 6.7.2 apply.

7.7.2—Welding Requirements

The welding requirements for FCMs shall be as specified in ANSI/AWS D1.2-97, Sections 2, 3, and 5.

Permanent backing for groove welds shall be of aluminum of the same alloy as the base metal. Temporary backing for groove welds may be of austenitic stainless steel, glass tape, ceramic, or anodized aluminum of the same alloy. Copper shall not be used as temporary backing.

The contract documents shall specify that intermittent fillet welding is not permitted.

7.7.3—Welding Procedures

The welding procedures shall be as specified in *Structural Welding Code—Aluminum*, ANSI/AWS D1.2, Section 4.

C7.6.2

Main load-carrying components fabricated with the aluminum alloys described in these Specifications have successful field experience in bridge structures. These alloys are inherently so tough that current testing procedures specified for metals cannot adequately characterize the fracture toughness of the material. Toughness is generally satisfactory, provided fatigue design guidelines are followed.

There are no simple standards for screening the alloys of interest for fracture toughness.

No reasonable Charpy V-notch impact fracture toughness correlation exists for aluminum alloys. Most aluminum alloys show no reduction in toughness with low temperatures and impact loads; in fact, they generally show increased resistance.

Material toughness may be described by the means of *R* curve analysis. In many instances, the *R* curves for structural alloys show no plateau but instead increasing resistance with crack extension (*Kosteas and Graf, 1984*).

C7.7.2

Copper used as temporary backing introduces dangers of weld contamination and corrosion problems.

7.7.4—Nondestructive Testing

The nondestructive testing for FCMs shall be as specified in *Structural Welding Code—Aluminum*, ANSI/AWS D1.2, Section 5.7.

7.7.5—Uplift and Slip of Deck Slabs

If noncomposite design is used, the slab should be connected to the supporting members to resist uplift and slip. The connection devices should be designed on the basis of full composite action, even if composite action is neglected in the design of the components supporting the deck.

7.7.6—Composite Sections

The following criteria apply to the design of aluminum beams composite with a concrete deck:

- The elastic design should be used based on the transformed section method.
- The shear connectors shall be of the same alloy and temper as the beam. Adequate strength and fatigue characteristics of shear connections shall be demonstrated by physical testing under representative conditions.
- Thermal stresses between the aluminum beams and the concrete should be considered in accordance with the temperature ranges and gradients specified in Articles 3.12.2 and 3.12.3, respectively.
- Reduction of allowable stresses due to welding shall be considered in accordance with the provisions of Article 7.4.2.2.
- All aluminum in contact with or embedded in concrete shall be coated with a chromate conversion coating.
- Steel reinforcing bars for the concrete deck shall be epoxy coated. For additional protection, the shear connectors may be painted.
- The contract documents shall specify that concrete mixed with chlorides shall be avoided.

C7.7.6

Composite action has been used in several aluminum bridges. The basic design principles used are the same as those used for steel bridges.

Shear connectors are usually extruded angles or Z-shapes with thickened sections at points of maximum shear force.

Where possible, welds should be located at points of least moment and be spliced for full strength.

The purpose of these coatings is to prevent galvanic action between dissimilar materials.

The chlorides in concrete will promote galvanic corrosion between steel reinforcement bars and aluminum shear connectors.

7.8—GENERAL DIMENSION AND DETAIL REQUIREMENTS

7.8.1—Effective Length of Span

The provisions of Article 6.7.1 shall apply.

7.8.2—Slenderness Ratios for Tension and Compression Members

Compression components shall satisfy the slenderness requirements specified herein.

- For main components or those in which more than 50 percent of the stress results from dead and live load:

$$\frac{KL}{r} \leq 100$$

- For bracing components:

$$\frac{KL}{r} \leq 120$$

For the purpose of this Article only, the radius of gyration may be computed on a notional section that neglects part of the area of a component, provided that:

- The capacity of the component based on the actual area and radius of gyration exceeds the factored loads, and
- The capacity of the notional component based on a reduced area and corresponding radius of gyration also exceeds the factored loads.

Where a component contains perforated cover plates, the radius of gyration and the effective area for carrying stress shall be determined for a transverse section taken at the maximum width of perforation. Where perforations are staggered in opposite cover plates, the cross-sectional area of the member shall be considered the same as for a section having perforations in the same transverse plane.

The unbraced length, L , shall be taken as follows:

- For the top chords of half-through trusses, the length between laterally supported panel points,
- For other main components, the length between panel point intersections or centers of end connections, and
- For secondary components, the length between the centers of the end connections of such components or centers of braced points.

Tension components, except rods, eyebars, cables, and plates, shall satisfy the slenderness ratios specified herein.

- For main components subjected to a reversal of stress: $\frac{L}{r} \leq 120$
- For other main components: $\frac{L}{r} \leq 150$
- For bracing components: $\frac{L}{r} \leq 200$

The possibility of wind-induced vibrations should be considered for components designed for slenderness limits higher than 120.

7.8.3—Minimum Thickness of Aluminum

The thickness of aluminum plate or components shall not be less than 0.1875 in., unless a smaller thickness can be justified through a bridge-specific evaluation of fabrication, shipping, and erection procedures.

7.8.4—Diaphragms and Cross-Frames

The following Articles of Section 6 shall apply:

- Article 6.7.4.2—Straight I-Beams
- Article 6.7.4.3—Straight Box Beams
- Article 6.7.4.4—Trusses and Arches

Extruded beam and plate girder spans shall be provided with cross-frames or diaphragms at each support and with intermediate cross-frames or diaphragms in all bays and spaced as required for stability and control of wind stresses in flanges of main members.

Diaphragms for extruded beams shall be at least one-third the beam depth. Diaphragms for plate girders shall be as deep as practicable.

End cross-frames or diaphragms shall be proportioned to transmit lateral forces to the bearings. Where the supports are skewed more than 20°, the intermediate cross-frames shall be placed normal to the main components.

Vertical connection plates, such as transverse stiffeners that connect diaphragms or cross-frames to the beam or girder shall be rigidly connected to both top and bottom flanges.

C7.8.3

The limiting thickness of aluminum depends primarily on the resistance to damage during handling and fabrication, not on the need for corrosion allowance. For large, major components 0.1875 in. is a reasonable minimum thickness.

Aluminum bridges erected in the 1960s and in use today employed thicknesses as small as 0.125 in. Standard extruded aluminum I-beams and channels have webs as thin as 0.13 in.

C7.8.4

Although this specification permits diaphragms as shallow as one-third of the depth of extruded beams, half-depth diaphragms are preferred where they are practical.

For plate girder bridges, cross-type or V-type intermediate cross-frames are preferred.

7.8.5—Lateral Bracing

7.8.5.1—General

The following provisions of Section 6 shall apply:

- Article 6.7.5.1—General
- Article 6.7.5.2—Straight I-Section
- Article 6.7.5.3—Straight Box sections
- Article 6.7.5.4—Trusses

7.8.5.2—Through-Spans

Where beams comprise the main components of through-spans, such components shall be stiffened against lateral deformation by gusset plates or knee braces with solid webs connected to the stiffeners on the main components and the floorbeams.

If the unsupported length of the edge of a gusset plate or solid web exceeds the criterion given by Eq. 7.8.5.2-1, the plate or web shall have a stiffening plate or angles connected along its unsupported edge.

$$\frac{L}{t} \leq \frac{0.29(B_p - F_{cy})}{D_p} \quad (7.8.5.2-1)$$

where:

L = unsupported length of plate (in.)

t = thickness of plate (in.)

B_p = coefficient specified in Table 7.10.1-2

D_p = coefficient specified in Table 7.10.1-2

F_{cy} = compressive yield stress specified in Table 7.4.2.1-1

7.8.6—Pins and Pin-Connected Elements

Pins shall be proportioned for the maximum shears and bending moments produced by the components connected.

The following Articles of Section 6 shall apply:

- Article 6.7.6.1—Location
- Article 6.8.7.2—Pin Plates
- Article 6.7.6.4—Pins and Nuts
- Article 6.8.6—Eyebars
- Article 6.8.7—Pin-Connected Plates

C7.8.5.2

This limit allows plate to be stressed to F_{cy} . Otherwise bracing is needed.

7.9—TENSION MEMBERS

7.9.1—General

In general, the section should be compact and proportioned to minimize the eccentricity between the gravity axis of the section and the applied factored load or working line. Consideration should also be given to the convenience of connection with other members or gusset plates.

7.9.2—Tensile Resistance

The factored resistance in terms of stress, F_r , shall be taken as the values given by Eqs. 7.9.2-1 and 7.9.2-2:

$$F_r = \phi_y F_{ty} \quad (7.9.2-1)$$

$$F_r = \phi_u \frac{F_u}{k_t} \quad (7.9.2-2)$$

where:

F_{ty} = tensile yield strength specified in Table 7.4.2.1-1 (ksi)

F_u = tensile ultimate strength specified in Table 7.4.2.1-1 (ksi)

ϕ_y, ϕ_u = resistance factors specified in Table 7.5.4-1

k_t = value specified in Table 7.10.1-1

The tensile resistance given by Eq. 7.9.2-1 shall be compared to a tensile stress computed by dividing the factored load by the area of the component without deduction for fastener holes. The resistance given by Eq. 7.9.2-2 shall be compared to a tensile stress based on the net section.

7.9.3—Effective Area of Angle and T-Sections

The effective area of a single-angle tension member, a T-section tension member, or each angle of a double-angle tension member in which the shapes are connected back-to-back on the same side of a gusset plate shall be assumed as the net area of the connected leg or flange, plus one-half of the area of the outstanding leg.

If a double-angle or T-section tension member is connected with the angles or flanges back-to-back on opposite sides of a gusset plate, the full net area of the shapes shall be considered effective.

Lug angles may be considered effective in transmitting stress, provided that they are connected with at least one-third more fasteners than required by the stress to be carried by the lug angle.

Where angles connect to separate gusset plates and the angles are connected by stay plates located as near the gusset as practicable or by other adequate means, the full net area of the angles shall be considered effective. If the angles are not so connected, only 80 percent of the net areas shall be considered effective.

7.9.4—Net Area

Unless modified herein, the provisions of Article 6.8.3 shall apply.

Unless larger holes are permitted in accordance with Article 7.14.2.2, the effective diameter of the hole shall be taken as 0.0625 in. greater than the nominal diameter of the hole.

7.10—COMPRESSION MEMBERS

7.10.1—General

Compressive resistance parameters shall be as specified in Tables 7.10.1-1, 7.10.1-2, and 7.10.1-3.

The cross-section of a compression member may be composed of several thin elements. The factored resistance for the section as a whole may be considered to be the weighted average factored resistance for the individual elements, where the resistance for each element is weighted in accordance with the ratio of the area of the element to the total area of the section. The factored resistance for the section as a whole used as a column shall not exceed that specified by Eq. 7.10.2-1 or Eq. 7.10.2-2.

C7.10.1

Formula for buckling constants for other alloys and tempers are given in the latest edition of the *Specifications for Aluminum Structures*.

Table 7.10.1-1—Value of Coefficients k_1 , k_2 , k_c , and k_t

Designation	ASTM B209	ASTM B209, B221, B308, B429
Alloy and Temper	Alloys 5086-H116, 5456-H116 and 5083-H321	Alloys 6061-T6 and T651
Regions farther than 1.0 in. from a weld:		
k_t	1.00	1.00
k_c	1.10	1.12
Regions within 1.0 in. from a weld:		
k_t	1.00	1.00
k_c	1.00	1.00
Crippling of flat plates in compression:		
k_1	0.50	0.35
k_2	2.04	2.27
Crippling of flat plates in flexure:		
k_1	0.50	0.50
k_2	2.04	2.04

Table 7.10.1-2—Formula for Buckling Parameters

Type of Stress and Member	ASTM B209, Alloys 5086-H116, 5456-H116 and 5083-H321		ASTM B209, B221, B308, B429, Alloys 6061-T6 and 6061-T651	
	Intercept (ksi)	Slope (ksi)	Intercept (ksi)	Slope (ksi)
Compression in Columns and Beam Flanges	$B_c = F_{cy} \left[1 + \left(\frac{F_{cy}}{1000} \right)^{\frac{1}{2}} \right]$	$D_c = \left(\frac{B_c}{20} \right) \left(\frac{6B_c}{E} \right)^{\frac{1}{2}}$	$B_c = F_{cy} \left[1 + \left(\frac{F_{cy}}{2250} \right)^{\frac{1}{2}} \right]$	$D_c = \left(\frac{B_c}{10} \right) \left(\frac{B_c}{E} \right)^{\frac{1}{2}}$
Compression in Flat Plates	$B_p = F_{cy} \left(1 + \frac{F_{cy}^{\frac{1}{3}}}{7.6} \right)$	$D_p = \left(\frac{B_p}{20} \right) \left(\frac{6B_p}{E} \right)^{\frac{1}{2}}$	$B_p = F_{cy} \left(1 + \frac{F_{cy}^{\frac{1}{3}}}{11.4} \right)$	$D_p = \left(\frac{B_p}{10} \right) \left(\frac{B_p}{E} \right)^{\frac{1}{2}}$
Compression in Plates Bent in Own Plane	$B_b = 1.3F_{cy} \left(1 + \frac{F_{cy}^{\frac{1}{3}}}{7.0} \right)$	$D_b = \left(\frac{B_b}{20} \right) \left(\frac{6B_b}{E} \right)^{\frac{1}{2}}$	$B_b = 1.3F_{cy} \left(1 + \frac{F_{cy}^{\frac{1}{3}}}{7.0} \right)$	$D_b = \left(\frac{B_b}{20} \right) \left(\frac{6B_b}{E} \right)^{\frac{1}{2}}$
Shear Stress in Flat Plate	$B_s = F_{sy} \left(1 + \frac{F_{sy}^{\frac{1}{3}}}{6.2} \right)$	$D_s = \left(\frac{B_s}{20} \right) \left(\frac{6B_s}{E} \right)^{\frac{1}{2}}$	$B_s = F_{sy} \left(1 + \frac{F_{sy}^{\frac{1}{3}}}{9.3} \right)$	$D_s = \left(\frac{B_s}{10} \right) \left(\frac{B_s}{E} \right)^{\frac{1}{2}}$

Table 7.10.1-3—Selected Values of Buckling Parameters—Nonwelded

Alloy and Temper	ASTM B209	ASTM B209	ASTM B209, B221, B308, B429	ASTM B209
	Alloy 5086-H116	Alloy 5456-H116 $t \leq 1.25$ in.	Alloy 6061-T6, T651	Alloy 5083-H321 $t \leq 1.5$ in
B_c (ksi)	30.2	31.4	39.4	30.2
D_c (ksi)	0.199	0.212	0.246	0.199
C_c	101	99	66	101
B_p (ksi)	36.1	37.7	45.0	36.1
D_p (ksi)	0.261	0.278	0.301	0.261
C_p	92	91	61	92
B_b (ksi)	48.1	50.1	66.8	48.1
D_b (ksi)	0.401	0.426	0.665	0.401
C_b	80	78	67	80
B_s (ksi)	22.5	27.2	25.8	25.6
D_s (ksi)	0.128	0.170	0.131	0.156
C_s	117	107	81	110
B_t (ksi)	34.6	36.0	43.2	34.6
D_t (ksi)	1.396	1.472	1.558	1.396
C_t	235	226	141	235
B_{tb} (ksi)	51.9	54.0	64.8	51.9
D_{tb} (ksi)	3.285	3.463	4.458	3.285
C_{tb}	84	82	55	84

7.10.2—Compressive Resistance of Columns

Unless further reduced by plate or component slenderness considerations, the factored compressive resistance in terms of stress shall be taken as:

- If $\lambda \leq S_2$, then:

$$F_r = \phi_c [B_c - D_{cc}\lambda] \leq \phi_s \frac{F_{cy}}{k_c} \quad (7.10.2-1)$$

- If $\lambda \geq S_2$, then:

$$F_r = \frac{\phi_c F_{cy}}{\lambda^2} \quad (7.10.2-2)$$

in which:

$$\lambda = \left(\frac{KL}{r} \right) \left(\frac{1}{\pi} \right) \sqrt{\frac{F_{cy}}{E}} \quad (7.10.2-3)$$

$$D_{cc} = \pi D_c \sqrt{\frac{E}{F_{cy}}} \quad (7.10.2-4)$$

$$S_2 = \frac{C_c}{\pi} \sqrt{\frac{F_{cy}}{E}} \quad (7.10.2-5)$$

where:

ϕ_s, ϕ_c = resistance factors specified in Table 7.5.4-1

B_c, C_c, D_c = parameters specified in Table 7.10.1-2 or 7.10.1-3

k_c = constants specified in Table 7.10.1-1

r = radius of gyration (in.)

K = column effective length factor specified in Article 4.6.2.5

F_{cy} = parameter specified in Table 7.4.2.1-1 (ksi)

E = compressive modulus of elasticity specified in Article 7.4.2 (ksi)

L = length of compression member between points of lateral supports (in.)

7.10.3—Compressive Resistance of Components of Columns—Outstanding Flanges and Legs

The factored compressive resistance in terms of stress shall be taken as:

- If $\frac{b}{t} \leq S_2$, then:

$$F_r = \phi_c \left[B_p - 5.1 D_p \frac{b}{t} \right] \leq \phi_s \frac{F_{cy}}{k_c} \quad (7.10.3-1)$$

- If $\frac{b}{t} \geq S_2$, then:

$$F_r = \frac{\phi_c \pi^2 E}{\left(5.1 \frac{b}{t} \right)^2} \quad (7.10.3-2)$$

in which:

$$S_2 = \frac{C_p}{5.1} \quad (7.10.3-3)$$

where:

b = width (in.)

t = thickness (in.)

k_c = coefficient specified in Table 7.10.1-1

C7.10.3

It is assumed that the strength of columns is limited by the local buckling strength of the legs and flanges. No allowance is made for the postbuckling strength in such members. Note that the formulas are in the same form as those of Eqs. 7.10.2-1 and 7.10.2-2. In Eqs. 7.10.3-1 and 7.10.3-2, the slenderness for plate buckling is assumed to be $5.1b/t$, where the coefficient 5.1 is the value that applies to a plate free on one edge and simply supported on the other.

Open section members that are unsymmetrical about one or both principal axes may be subject to failure by combined torsion and flexure. For single or double-angles and T-sections, an adequate factor of safety is provided against this type of failure. Other unsymmetrical, open shapes, such as channels, lipped angles, or hat shapes, should not be used as columns unless an analysis is made of the resistance to buckling by combined torsion and flexure.

C_p, D_p
 B_p = parameters specified in Table 7.10.1-2 or 7.10.1-3

ϕ_c, ϕ_s = resistance factors specified in Table 7.5.4-1

F_{cy} = parameter specified in Table 7.4.2.1-1 (ksi)

7.10.4—Compressive Resistance of Components of Columns, Gross Section—Flat Plates with Both Edges Supported

7.10.4.1—General

The factored compressive resistance in terms of stress shall be taken as:

- If $\frac{b}{t} \leq S_2$, then:

$$F_r = \phi_c \left[B_p - 1.6 D_p \frac{b}{t} \right] \leq \phi_s \frac{F_{cy}}{k_c} \quad (7.10.4.1-1)$$

- If $\frac{b}{t} \geq S_2$, but is less than 60 percent of the maximum column slenderness, kL/r , then:

$$F_r = \frac{\phi_c k_2 \sqrt{B_p E}}{1.6 \frac{b}{t}} \quad (7.10.4.1-2)$$

in which:

$$S_2 = \frac{k_1 B_p}{1.6 D_p} \quad (7.10.4.1-3)$$

where:

B_p, D_p = parameters specified in Tables 7.10.1-2 and 7.10.1-3

ϕ_c, ϕ_s = resistance factors specified in Table 7.5.4-1

k_1, k_2
and k_c = constants specified in Table 7.10.1-1

F_{cy} = parameter from Table 7.4.2.1-1 (ksi)

F_r = factored resistance (ksi)

kL/r = maximum slenderness ratio of column

b/t = width to thickness ratio for column flange

E = compressive modulus of elasticity

C7.10.4.1

The equivalent slenderness ratio is $1.6b/t$, the value that applies to a plate simply supported on both longitudinal edges. In this range of b/t values, the local buckling strength is essentially the same as the ultimate or “crippling” strength.

Eq. 7.10.4.1-2 is based on the crippling strength of a plate simply supported on both longitudinal edges. This strength may be appreciably greater than the local buckling strength for thin sections.

These provisions take advantage of the postbuckling strength of plate elements supported on two edges because in general such elements may buckle without causing failure of the member. However, there are cases where the reduced stiffness that accompanies local buckling of these elements may necessitate a reduction in the factored resistance determined from Article 7.10.1. Article 7.10.3 does not take advantage of postbuckling strength; therefore, no provision is needed for any additional effect of local buckling of the types of elements covered.

specified in Article 7.4.2 (ksi)

7.10.4.2—Effect of Local Buckling of Elements on Column Strength

If the maximum b/t for the flange of a rectangular tube or formed-closed shape is greater than the value of S_2 and also greater than 60 percent of the maximum slenderness ratio for the column, the factored resistance shall be taken as:

$$F_r = \frac{\phi_c \pi^2 E}{\left(\frac{kL}{r}\right)^{2/3} \left(\frac{1.6b}{t}\right)^{4/3}} \quad (7.10.4.2-1)$$

where:

- ϕ_c = resistance factor specified in Table 7.5.4-1
- kL/r = maximum slenderness ratio of column
- b/t = width to thickness ratio for column flange
- E = compressive modulus of elasticity specified in Article 7.4.2 (ksi)

7.10.5—Compressive Resistance of Components of Columns, Gross Section—Curved Plates Supported on Both Edges, Walls of Round, or Oval Tubes

The factored compressive resistance in terms of stress shall be taken as:

- If $\frac{R}{t} \leq S_2$, then:

$$F_r = \phi_c \left(B_t - D_t \sqrt{\frac{R}{t}} \right) \leq \phi_s \frac{F_{cy}}{k_c} \quad (7.10.5-1)$$

- If $\frac{R}{t} \geq S_2$, then:

$$F_r = \frac{\phi_c \pi^2 E}{16 \left(\frac{R}{t}\right) \left[1 + \sqrt{\frac{R}{1225t}}\right]^2} \quad (7.10.5-2)$$

where:

- S_2 = C_t
- B_t, D_t = parameters specified in Table 7.10.1-2 and 7.10.1-3 (ksi)
- ϕ_c, ϕ_s = resistance factor specified in Table 7.5.4-1
- k_c = values specified in Table 7.10.1-1

C7.10.4.2

Eq. 7.10.4.2-1 applies only to those cases in which local buckling of an element precipitates overall buckling of the entire column. This equation reduces the factored resistance to account for that situation.

C7.10.5

Formulas are based on the local buckling strength of tubes in direct compression.

E = compressive modulus of elasticity specified in Article 7.4.2 (ksi)

R = maximum midthickness radius (in.)

t = thickness (in.)

7.11—FLEXURAL MEMBERS

7.11.1—Tensile Resistance of Flexural Member

7.11.1.1—Net Section

No reduction in the cross-section area shall be made for bolt holes in any flexural member, unless the reduction in the cross-section area, as determined in accordance with Article 7.9.4 and Article 7.9.3, exceeds 15 percent of the gross cross-section, in which case the excess over 15 percent shall be deducted.

7.11.1.2—Tension in Extreme Fibers of Beams, Structural Shapes Bent about Strong Axis, Rectangular Tubes

The factored resistance in terms of stress shall be taken as the lesser of the values specified by either Eq. 7.11.1.2-1 or 7.11.1.2-2.

$$F_r = \phi_y F_{ty} \quad (7.11.1.2-1)$$

$$F_r = \phi_u \frac{F_u}{k_t} \quad (7.11.1.2-2)$$

where:

F_{ty} = tensile yield strength specified in Table 7.4.2.1-1 (ksi)

F_u = tensile strength specified in Table 7.4.2.1-1 (ksi)

ϕ_y, ϕ_u = resistance factors specified in Table 7.5.4-1

7.11.1.3—Tension in Extreme Fibers of Beams, Round, or Oval Tubes

The factored resistance in terms of stress shall be taken as the lesser of the values specified by either Eq. 7.11.1.3-1 or 7.11.1.3-2.

$$F_r = \phi_y 1.17 F_{ty} \quad (7.11.1.3-1)$$

$$F_r = \phi_u 1.24 \frac{F_u}{k_t} \quad (7.11.1.3-2)$$

C7.11.1.3

The resistance in terms of tensile stress for round and oval tubes subjected to flexure is somewhat higher than for structural shapes. Analysis and tests have demonstrated that yielding or failure of tubular beams does not occur until the moment considerably exceeds the value predicted by the flexure formula based on triangular stress distribution. The constants of 1.17 and 1.24 were developed on this basis and are analogous to shape factors. The factor k_t is provided for the tensile strength for some alloys that do not develop sufficiently high tensile properties in the presence of stress

7.11.1.4—Tension in Extreme Fibers of Beams—Shapes Bent about Weak Axis, Rectangular Bars, Plates

The factored resistance in terms of stress shall be taken as the lesser of the values specified by either Eq. 7.11.1.4-1 or 7.11.1.4-2.

$$F_r = \phi_y 1.30 F_{ty} \quad (7.11.1.4-1)$$

$$F_r = \phi_u 1.42 \frac{F_{tu}}{k_t} \quad (7.11.1.4-2)$$

7.11.2—Compressive Resistance of Flexural Members

7.11.2.1—Compression in Beams, Extreme Fiber, Gross Section, Single-Web Beams Bent about Strong Axis

The factored resistance in terms of stress shall be taken as:

- If $\frac{L_b}{r_y} \leq S_2$, then:

$$F_r = \phi_b \left(B_c - \frac{D_c L_b}{1.2 r_y} \right) \leq \phi_s F_{cy} \quad (7.11.2.1-1)$$

- If $\frac{L_b}{r_y} \geq S_2$, then:

$$F_r = \frac{\phi_b \pi^2 E}{\left(\frac{L_b}{1.2 r_y} \right)^2} \quad (7.11.2.1-2)$$

in which:

$$S_2 = 1.2 C_c \quad (7.11.2.1-3)$$

where:

C_c, D_c, B_c = parameters specified in Table 7.10.1-3

r_y = radius of gyration of the beam about axis parallel to the web (in.)

ϕ_b, ϕ_s = resistance factors specified in Table 7.5.4-1

L_b = length of beam between points at which the compression flange is supported against lateral movement, or length of cantilever beam from free end to point at

concentrations.

C7.11.1.4

As in the case of round tubes, theory and tests have shown that aluminum alloy members of these shapes can undergo bending moments that are considerably higher than those predicted on the basis of triangular stress distribution.

C7.11.2.1

The compressive stresses in single-web structural shapes and built-up sections bent about the strong axis are based on the lateral torsional buckling strength of beams. The first formula for resistance in the inelastic stress range for beams is based on the straight line approximation to the tangent modulus buckling curve that is also used for columns. In deriving the resistance in terms of stress for beams, it was assumed that the beam is held in an upright position at the supported ends. The strengthening effect of any restraint against rotation of the flanges at the supports was neglected. The second formula is based on a conservative approximation to the elastic buckling strength of beams, with L_b/r_y replacing a more complicated function of the length and cross-section properties.

Because of the approximation, the formulas give very conservative results for certain conditions, namely for values of L_b/r_y exceeding about 50; for load distributions such that the bending moment near the center of the beam is appreciably less than the maximum bending moment in the beam; and for beams with transverse loads applied to a flange and acting away from the shear center. To compute more precise values of factored compressive resistance in terms of stress for these cases, the value of r_y may be replaced by r_{ye} given by one of the following formulas:

- For beam spans subjected to end moment only or to transverse loads applied at the neutral axis of the beam:

$$r_{ye} = \frac{k_b}{1.7} \sqrt{\frac{I_y d}{S_c}} \sqrt{1 + 0.152 \frac{J}{I_y} \left(\frac{L_b}{d} \right)^2} \quad (C7.11.2.1-1)$$

which the compression flange is supported against lateral movement (in.)

E = compressive modulus of elasticity specified in Article 7.4.2 (ksi)

The factored resistance of elastically supported flanges, including the compression flange of a hat-shaped beam loaded with the two flanges in compression, shall be determined with the following effective value of L_b/r_y substituted into Eqs. 7.11.2.1-1 and 7.11.2.1-2:

$$\left(\frac{L_b}{r_y}\right)_{\text{effective}} = 2.74 \sqrt{\frac{EA_c^2}{\beta I_{yc}}} \quad (7.11.2.1-4)$$

where:

A_c = area of compression element taken as that of the compression flange plus one-third of the area of web between compression flange and neutral axis (in.²)

β = spring constant taken as the magnitude of a transverse force applied at the compression flange to a 1.0-in. long strip of the member to cause a 1.0-in. deflection of the flange (kip/in./in.); the strip shall be supported to be stable but not cause additional restraint or distortion

I_{yc} = moment of inertia of compression element about axis parallel to vertical web (in.⁴)

E = compressive modulus of elasticity specified in Article 7.4.2 (ksi)

- For beams subjected to transverse loads applied on the top or bottom flange, where the load is free to move laterally with the beam if the beam should buckle:

$$r_{ye} = \frac{k_b}{1.7} \sqrt{\frac{I_y d}{S_c} \left[\pm 0.5 + \sqrt{1.25 + 0.152 \frac{J}{I_y} \left(\frac{L_b}{d}\right)^2} \right]} \quad (C7.11.2.1-2)$$

where:

I_y = moment of inertia of beam about axis parallel to web (in.⁴)

S_c = section modulus of beam, compression side (in.³)

J = torsional inertia of beam; an approximate value of J may be calculated by assuming the section to be composed of rectangles and letting J equal the sum of the terms $bt^3/3$ for each rectangle (in.⁴)

L_b = length of beam between points at which the compression flange is supported against lateral movement or length of cantilever beam from free end to point at which the compression flange is supported against lateral movement (in.)

d = depth of beam (in.)

The plus sign in front of the term “0.5” applies if the load is on the tension flange; the minus sign applies if the load is on the compression flange.

Values of the coefficient k_b are tabulated below:

- For beams restrained against lateral displacement at both ends of span.

(1) uniform bending moment, uniform transverse load, or two equal concentrated loads equidistant from the center of the span 1.00

(2) bending moment varying uniformly from a value of M_1 at one end to M_2 at the other end

$M_1/M_2 = 0.5$	1.14
$M_1/M_2 = 0$	1.33
$M_1/M_2 = -0.5$	1.53
$M_1/M_2 = -1.0$	1.60
Concentrated load at center of span	1.16

- For cantilever beams

(1) concentrated load at end of span 1.13

(2) uniform transverse load 1.43

For beams that are unsymmetrical about the horizontal axis, r_y , I_y , S_{cy} , and J should be determined as though both flanges were the same as the compression flange.

7.11.2.2—Compression in Beams, Extreme Fiber, Gross Section, Round or Oval Tubes

The factored resistance in terms of stress shall be taken as:

If $\frac{R_b}{t} \leq S_2$, then:

$$F_r = \phi_b \left[B_{ib} - D_{ib} \sqrt{\frac{R_b}{t}} \right] \leq 1.17 \phi_s F_{cy} \quad (7.11.2.2-1)$$

where:

R_b = midthickness radius of curvature of plates (in.)

S_2 = C_{ib}

C_{ib} , B_{ib} ,
 D_{ib} = parameters specified in Table 7.10.1-3

ϕ_b , ϕ_s = resistance factor specified in Table 7.5.4-1

t = thickness (in.)

For R_b/t values greater than S_2 , the allowable bending stress shall be determined from the relevant formula for tubes in compression as specified in Article 7.10.5.

7.11.2.3—Compression in Beams, Extreme Fiber, Gross Section, Solid Rectangular Beams

The factored resistance in terms of stress shall be taken as:

- If $\frac{d}{t} \sqrt{\frac{L_b}{d}} \leq S_2$, then:

$$F_r = \phi_b \left[B_b - 2.3 D_b \frac{d}{t} \sqrt{\frac{L_b}{d}} \right] \leq 1.3 \phi_s F_{cy} \quad (7.11.2.3-1)$$

- If $\frac{d}{t} \sqrt{\frac{L_b}{d}} > S_2$, then:

C7.11.2.3

The formulas for rectangular beams are based on the lateral, torsional buckling strength of the beams.

$$F_r = \frac{\phi_b \pi^2 E}{5.29 \left(\frac{d}{t}\right)^2 \left(\frac{L_b}{d}\right)} \quad (7.11.2.3-2)$$

in which:

$$S_2 = \frac{C_b}{2.3} \quad (7.11.2.3-3)$$

where:

$B_b, D_b,$
 C_b = parameters specified in Tables 7.10.1-2 and 7.10.1-3 (ksi)

ϕ_b, ϕ_s = resistance factors specified in Table 7.5.4-1

E = compressive modulus of elasticity specified in Article 7.4.2 (ksi)

7.11.2.4—Compression in Beams, Extreme Fiber, Gross Section, Rectangular Tubes, and Box Sections

C7.11.2.4

The factored resistance in terms of stress shall be taken as:

- If $\frac{L_b S_c}{I_y} \leq S_2$, then:

$$F_r = \phi_b \left(B_c - 1.6 D_c \sqrt{\frac{L_b S_c}{I_y}} \right) \leq \phi_s F_{cy} \quad (7.11.2.4-1)$$

- If $\frac{L_b S_c}{I_y} \geq S_2$, then:

$$F_r = \frac{\phi_b \pi^2 E}{2.56 \left(\frac{L_b S_c}{I_y}\right)} \quad (7.11.2.4-2)$$

in which:

$$S_2 = \left(\frac{C_c}{1.6}\right)^2 \quad (7.11.2.4-3)$$

where:

$B_c, D_c,$
 C_c = parameters specified in Table 7.10.1-3

The formulas for box beams are based on the lateral, torsional buckling strength of the beams. In deriving these formulas, it was recognized that lateral buckling will govern the design only for relatively deep, narrow box beams and for these members the torsion constant J is roughly proportional to I_y .

ϕ_s, ϕ_b = resistance factors specified in Table 7.5.4-1

E = compressive modulus of elasticity specified in Article 7.4.2 (ksi)

7.11.3—Compressive Resistance of Flexural Members Limited by Plate Slenderness

7.11.3.1—General

C7.11.3.1

Where the factored resistance in terms of stress for individual elements are determined from Articles 7.11.3.2 through 7.11.3.7, the process of determining the weighted average resistance for the beam flanges may be applied. The beam flange may be considered to consist of the flange proper plus one-sixth of the area of the web or webs.

The weighted average compressive resistance in terms of stress, F_{ba} , for a trapezoidally formed sheet beam, determined according to Article 7.10.1, may be taken as:

$$F_{ba} = \frac{F_{bf} + F_{bh} \left(\frac{h}{3b} \right)}{1 + \frac{h}{3b}} \quad (7.11.3.1-1)$$

where:

F_{bf} = factored resistance in terms of stress for the flange proper; taken as F_r as specified in Article 7.10.4 (ksi)

F_{bh} = factored resistance in terms of stress for webs; taken as F_r as specified in Article 7.11.3.6 or Article 7.11.3.7 (ksi)

h = height of shear web as specified in Article 7.11.3.6 (in.)

b = width of compression flange (in.)

Eq. 7.11.3.1-1 may also be applied to the factored resistance in terms of tensile stress in trapezoidally formed sheet beams. In regions of positive moments with load applied to concave side of the deformed beam, F_{ba} shall be taken as the weighted average factored resistance in terms of tensile stress, F_{bf} shall be taken as F_r as specified in Article 7.9.2, and F_{bh} shall be taken as F_r as specified in Article 7.11.1.4.

In regions of negative moments with load applied to convex side of the deformed beam, the factored resistance in terms of tensile stress on the tension flange of a formed sheet beam shall not exceed the compressive stress that would be allowed on the same flange if it were in compression.

This provision is required to take account of the effects of flange curling, the tendency of the tension flange to bend toward the neutral axis. It governs design only where the tension flange is wider than the compression flange.

7.11.3.2—Compression in Components of Beams with Component under Uniform Compression, Gross Section, Outstanding Flanges

7.11.3.2.1—General

The factored resistance in terms of stress shall be taken as:

- If $\frac{b}{t} \leq S_2$, then:

$$F_r = \phi_c \left[B_p - 5.1D_p \left(\frac{b}{t} \right) \right] \leq \phi_s F_{cy} \quad (7.11.3.2.1-1)$$

- If $\frac{b}{t} \geq S_2$, but is less than $0.16 \frac{L_b}{r_y}$, then:

$$F_r = \frac{\phi_c k_2 \sqrt{B_p E}}{\left(5.1 \frac{b}{t} \right)} \quad (7.11.3.2.1-2)$$

in which:

$$S_2 = \frac{k_1 B_p}{5.1D_p} \quad (7.11.3.2.1-3)$$

where:

F_r = factored resistance in terms of compressive bending stress in beam flange (ksi)

L_b/r_y = slenderness ratio for beam

b/t = width to thickness ratio for beam flange

E = compressive modulus of elasticity specified in Article 7.4.2 (ksi)

B_p, D_p = parameters specified in Table 7.10.1-3 (ksi)

k_1, k_2 = constants specified in Table 7.10.1-1

ϕ_s, ϕ_c = resistance factors specified in Table 7.5.4-1

C7.11.3.2.1

Eqs. 7.11.3.2.1-1 and 7.11.3.2.1-2 are based on the crippling strength of an outstanding flange simply supported on one edge.

7.11.3.2.2—Effect of Local Buckling of Elements on Resistance

C7.11.3.2.2

If the value of b/t for outstanding flanges is greater than the value of S_2 and also greater than 0.16 (L_b/r_y), the factored resistance in terms of stress shall be taken as:

$$F_{rb} = \frac{\phi_c \pi^2 E}{\left(\frac{L_b}{1.2r_y} \right)^2 \left(\frac{5.1b}{t} \right)^4} \quad (7.11.3.2.2-1)$$

These provisions take advantage of the postbuckling strength of thin elements. They take account of the effect that the reduced stiffness due to local buckling may have on the lateral buckling strength of single-web beams. Any such effects on multiweb beams are considered to be negligible because of their high torsional stiffness.

7.11.3.3—Compression in Components of Beams with Component under Uniform Compression, Gross Section, Flat Plates with Both Edges Supported

C7.11.3.3

The factored resistance in terms of stress shall be taken as:

Formulae are based on the crippling strength of a plate simply supported on both edges.

- If $\frac{b}{t} \leq S_2$, then:

$$F_r = \phi_c \left[B_p - 1.6D_p \left(\frac{b}{t} \right) \right] \leq \phi_s F_{cy} \quad (7.11.3.3-1)$$

- If $\frac{b}{t} > S_2$, then:

$$F_r = \frac{\phi_c k_2 \sqrt{B_p E}}{1.6 \frac{b}{t}} \quad (7.11.3.3-2)$$

in which:

$$S_2 = \frac{k_1 B_p}{1.6D_p} \quad (7.11.3.3-3)$$

where:

B_p, D_p = parameters specified in Table 7.10.1-3 (ksi)

k_1, k_2 = constants specified in Table 7.10.1-1

ϕ_s, ϕ_c = resistance factors specified in Table 7.5.4-1

E = compressive modulus of elasticity specified in Article 7.4.2 (ksi)

7.11.3.4—Compression in Components of Beams—Curved Sections

The factored resistance in terms of stress shall be taken as:

- If $\frac{R_b}{t} \leq S_2$, then:

$$F_r = \phi_c \left[B_t - D_t \sqrt{\frac{R_b}{t}} \right] \leq 1.17 \phi_s F_{cy} \quad (7.11.3.4-1)$$

- If $\frac{R_b}{t} > S_2$, then:

$$F_r = \frac{\phi_c \pi^2 E}{16 \left(\frac{R_b}{t} \right) \left(1 + \sqrt{\frac{R_b}{1225t}} \right)^2} \quad (7.11.3.4-2)$$

in which:

$$S_2 = C_t \quad (7.11.3.4-3)$$

where:

B_t, D_t = parameters specified in Table 7.10.1-3 (ksi)

ϕ_c, ϕ_s = resistance factors specified in Table 7.5.4-1

E = compressive modulus of elasticity specified in Article 7.4.2 (ksi)

t = thickness (in.)

R_b = midthickness radius (in.)

7.11.3.5—Compression in Components of Beams with Component under Bending in Own Plane, Gross Section, Flat Plates with Compression Edge Free, Tension Edge Supported

The factored resistance in terms of stress shall be taken as:

- If $\frac{b}{t} \leq S_2$, then:

$$F_r = \phi_c \left[B_b - 3.5 D_b \left(\frac{b}{t} \right) \right] \leq 1.3 \phi_s F_{cy} \quad (7.11.3.5-1)$$

- If $\frac{b}{t} \geq S_2$, then:

C7.11.3.4

The expressions for curved sections are taken from ASCE Structural Division Paper 6744 *Guide for the Design of Aluminum Formed Sheet Building Sheathing* (1969). They apply to curved components of beams other than tubes, the latter being covered by Article 7.11.2.2.

C7.11.3.5

The coefficients in the first formula for inelastic buckling strength were assumed to be the same as for rectangular beams because calculations and tests have shown that the apparent stress (Mc/I) at which the yield strength is reached in the outer fiber of sections such as tees, angles, and channels is even higher than for rectangular beams. The equivalent slenderness ratio was assumed to be $3.5b/t$, which implies partial restraint against rotation at the supported edge.

The second formula is based on elastic buckling strength. This type of component is assumed to have negligible postbuckling strength.

$$F_r = \frac{\phi_c \pi^2 E}{\left(3.5 \frac{b}{t}\right)^2} \quad (7.11.3.5-2)$$

in which:

$$S_2 = \frac{C_b}{3.5} \quad (7.11.3.5-3)$$

where:

B_b, D_b, C_b = parameters specified in Tables 7.10.1-2 and 7.10.1-3 (ksi)

ϕ_c, ϕ_s = resistance factors specified in Table 7.5.4-1

E = compressive modulus of elasticity specified in Article 7.4.2 (ksi)

t = thickness (in.)

b = width (in.)

7.11.3.6—Webs of Beams, Gross Section, Flat Plates with Both Edges Supported

The factored resistance in terms of stress shall be taken as:

- If $\frac{h}{t} \leq S_2$, then:

$$F_r = \phi_c \left[B_b - 0.67 D_b \left(\frac{h}{t} \right) \right] \leq 1.3 \phi_s F_{cy} \quad (7.11.3.6-1)$$

- If $\frac{h}{t} \geq S_2$, then:

$$F_r = \frac{\phi_c k_2 \sqrt{B_b E}}{0.67 \left(\frac{h}{t} \right)} \quad (7.11.3.6-2)$$

in which:

$$S_2 = \frac{k_1 B_b}{0.67 D_b} \quad (7.11.3.6-3)$$

where:

h = depth of the web (in.)

t = thickness of web (in.)

B_b, D_b = parameters specified in Tables 7.10.1-2 and 7.10.1-3 (ksi)

C7.11.3.6

The equivalent slenderness ratio used is $0.67h/t$, which applies to a plate in bending, which is simply supported on both edges.

The second formula is based on crippling strength.

ϕ_c, ϕ_s = resistance factors specified in Table 7.5.4-1

E = compressive modulus of elasticity specified in Article 7.4.2 (ksi)

7.11.3.7—Webs of Beams with Longitudinal Stiffener, Both Edges Supported

The factored resistance in terms of stress shall be taken as:

- If $\frac{h}{t} \leq S_2$, then:

$$F_r = \phi_c \left[B_b - 0.29 D_b \left(\frac{h}{t} \right) \right] \leq 1.3 \phi_s F_{cy} \quad (7.11.3.7-1)$$

- If $\frac{h}{t} \geq S_2$, then:

$$F_r = \frac{\phi_c k_2 \sqrt{B_b E}}{0.29 \left(\frac{h}{t} \right)} \quad (7.11.3.7-2)$$

in which:

$$S_2 = \frac{k_1 B_b}{0.29 D_b} \quad (7.11.3.7-3)$$

where:

B_b, D_b = parameters specified in Table 7.10.1-3 (ksi)

k_1, k_2 = constants specified in Table 7.10.1-1

ϕ_c, ϕ_s = resistance factors specified in Table 7.5.4-1

E = compressive modulus of elasticity specified in Article 7.4.2 (ksi)

t = thickness (in.)

h = depth of web (in.)

7.11.4—Shear Resistance

7.11.4.1—Shear—Unstiffened Flat Webs

The factored resistance in terms of stress shall be taken as:

C7.11.3.7

The equivalent slenderness ratio is $0.29h/t$, based on simple support at the edges and at the stiffener.

The second formula is based on crippling strength.

C7.11.4.1

Resistance shear stresses in unstiffened flat webs are determined by the calculated buckling strength for a web with partial restraint against rotation at the attachment to the flanges. The corresponding value of

- If $\frac{h}{t} \leq S_2$, then:

$$F_r = \phi_s \left[B_s - 1.25 D_s \left(\frac{h}{t} \right) \right] \leq \phi_s F_{sy} \quad (7.11.4.1-1)$$

- If $\frac{h}{t} \geq S_2$, then:

$$F_r = \frac{\phi_c \pi^2 E}{\left(1.25 \frac{h}{t} \right)^2} \quad (7.11.4.1-2)$$

where:

S_2 = for 6061-T6, 6061-T651, and 6063-T6, $S_2 = C_s/1.36$; for 5083-H321, 5086-H116, and 5456-H116, $S_2 = C_s/1.58$

B_s, D_s = parameters specified in Table 7.10.1-3 (ksi)

ϕ_s, ϕ_c = resistance factors specified in Table 7.5.4-1

E = compressive modulus of elasticity specified in Article 7.4.2 (ksi)

t = thickness (in.)

h = depth of web (in.)

F_{sy} = parameter specified in Table 7.4.2.1-1 (ksi)

7.11.4.2—Shear in Webs—Stiffened Flat Webs

The factored resistance in terms of stress shall be taken as:

- If $\frac{a_e}{t} \leq S_2$, then:

$$F_r = 1.375 \phi_s \left[B_s - 1.25 D_s \left(\frac{a_e}{t} \right) \right] \leq \phi_s F_{sy} \quad (7.11.4.2-1)$$

- If $\frac{a_e}{t} \geq S_2$, then:

$$F_r = \frac{1.375 \phi_c \pi^2 E}{\left(1.25 \frac{a_e}{t} \right)^2} \quad (7.11.4.2-2)$$

in which:

the equivalent slenderness ratio is $1.25h/t$.

C7.11.4.2

Resistance stresses for stiffened flat webs are determined on the basis of assumptions similar to those used for unstiffened webs except that a factor of 1.375 is applied to the buckling strength of stiffened beam webs. Tests have demonstrated that shear stresses in such webs can considerably exceed the calculated buckling strength without appreciably affecting the behavior of the beam.

$$a_e = \frac{a_1}{\sqrt{1 + 0.7 \left(\frac{a_1}{a_2} \right)^2}} \quad (\text{in.}) \quad (7.11.4.2-3)$$

where:

S_2 = for 6061-T6, 6061-T651, and 6063-T6, $S_2 = C_s/1.36$; for 5083-H321, 5086-H116, and 5456-H116, $S_2 = C_s/1.58$

B_s, D_s = parameters specified in Table 7.10.1-3 (ksi)

a_e = equivalent width of rectangular panel (in.)

a_1 = shorter dimension of rectangular panel (in.)

a_2 = longer dimension of rectangular panel (in.)

ϕ_c, ϕ_s = resistance factors specified in Table 7.5.4-1

E = compressive modulus of elasticity specified in Article 7.4.2 (ksi)

F_{sy} = parameter specified in Table 7.4.2.1-1 (ksi)

t = thickness (in.)

7.11.5—Design of Stiffeners

7.11.5.1—Longitudinal Stiffeners for Webs

If a longitudinal stiffener is used on a beam web, it shall be located so that the distance from the toe of the compression flange to the centroid of the stiffener is 0.4 times the distance from the toe of the compression flange to the neutral axis of the beam.

The moment of inertia of a longitudinal stiffener, I_ℓ , shall satisfy:

$$I_\ell \geq \frac{0.02 f \alpha t h^3}{E} \left[\left(1 + \frac{6A_\ell}{ht} \right) \left(\frac{s}{h} \right)^2 + 0.4 \right] \quad (7.11.5.1-1)$$

where:

I_ℓ = moment of inertia of the longitudinal stiffener about the web of the beam (in.⁴)

α = 1.0 for stiffener consisting of equal members on both sides of the web

α = 3.5 for stiffener consisting of member on only one side of web

h = depth of web between flanges (in.)

- t = thickness of web (in.)
- f = unfactored compressive stress at toe of flange (ksi)
- s = distance between transverse stiffeners (in.)
- A_t = gross area of cross-section of longitudinal stiffener (in.²)
- E = compressive modulus of elasticity specified in Article 7.4.2 (ksi)

For a stiffener consisting of equal elements on both sides of the web, the moment of inertia shall be the sum of the moments of inertia about the centerline of the web.

For a stiffener consisting of a member on one side only, the moment of inertia shall be taken about the face of the web in contact with the stiffener.

7.11.5.2—Transverse Stiffeners for Shear in Webs

C7.11.5.2

The moment of inertia of transverse web stiffeners, I_s , shall not be less than the value specified by either Eq. 7.11.5.2-1 or 7.11.5.2-2:

- If $\frac{s}{h} \leq 0.4$, then:

$$I_s = \frac{Vh^2}{3.07\phi E} \frac{s}{h} \quad (7.11.5.2-1)$$

- If $\frac{s}{h} > 0.4$, then:

$$I_s = \frac{Vh^2}{19.2\phi E} \frac{h}{s} \quad (7.11.5.2-2)$$

where:

- I_s = moment of inertia of transverse stiffener (in.⁴)
- V = factored shear force on the web at location of stiffener (kip)
- h = depth of web (in.)
- s = stiffener spacing (in.)
- ϕ = resistance factor specified in Table 7.5.4-1

Where a transverse stiffener is composed of a pair of elements, one on each side of the web, the stiffener spacing shall be taken as the clear distance between the

pairs of stiffeners. When a transverse stiffener is composed of an element on only one side of the web, the stiffener spacing shall be taken as the distance between lines of connection to the web.

For a transverse stiffener composed of elements of equal size on each side of the web, the moment of inertia of the stiffener shall be taken about the centerline of the web. For a transverse stiffener composed of an element on one side only of the web, the moment of inertia of the stiffener shall be taken about the face of the web in contact with the stiffener.

In determining the moment of inertia, the depth of web shall be taken as the full depth of the web, regardless of whether a longitudinal stiffener is present.

Transverse stiffeners shall extend from flange-to-flange but need not be connected to either flange, unless the stiffener is functioning as a connection plate, in which case the provisions of Article 7.6.1.3.1 shall apply.

Unless the outer edge of a stiffener leg is continuously stiffened, its thickness shall not be less than one-twelfth the width of the leg.

If the transverse stiffener is not connected to either flange, the contract documents should require support to prevent distortion of the beam during transportation.

7.11.5.3—Stiffeners for Outstanding Flanges

Outstanding flanges stiffened at the free edge shall be considered as being supported on both edges if:

- The radius of gyration of the lip or bulb satisfies:

$$r_L \geq b/5, \text{ or} \quad (7.11.5.3-1)$$

- A simple rectangular lip, having the same thickness as the flange, satisfies:

$$b_L \geq b/3 \quad (7.11.5.3-2)$$

where:

r_L = radius of gyration of lip or bulb about the midthickness of the flange from which it projects (in.)

b = clear width of flange (in.)

b_L = clear width of lip (in.)

The factored resistance of flanges meeting the foregoing requirements shall be determined in accordance with the provisions of Article 7.10.4 or Article 7.11.3.3. The factored resistance of stiffeners in terms of stress shall be determined in accordance with Article 7.10.3 or Article 7.11.3.2. The area of stiffening lips or bulbs may be included with the area of the rest of the section in determining stresses caused by the loads.

7.11.5.4—Bearing Stiffeners

Where possible, vertical stiffeners shall be placed in pairs at bearings and other points of concentrated load. The stiffeners shall be connected to the web to distribute the reaction force into the web and shall be fitted to form a tight and uniform bearing against the loaded flanges, unless welds designed to transmit the full reaction or load are provided between flange and stiffener.

Only that part of a stiffener cross-section that lies outside the fillet of the flange angle shall be considered as effective in bearing. Bearing stiffeners shall not be crimped.

The moment of inertia of the bearing stiffener, I_b , shall satisfy:

$$I_b \geq I_s + \frac{Ph^2}{\phi\pi^2 E} \quad (7.11.5.4-1)$$

where:

I_b = required moment of inertia of bearing stiffener (in.⁴)

I_s = moment of inertia required to resist shear buckling (in.⁴)

P = factored reaction force (kip)

h = depth of web between flanges (in.)

ϕ = resistance factor specified in Table 7.5.4-1

E = compressive modulus of elasticity (ksi)

7.12—TORSION**7.12.1—General**

Structural members shall be braced against lateral deflection and twisting in order to prevent lateral-torsional buckling prior to reaching their full in-plane capacity.

7.12.2—Compression Members Subjected to Torsion

Compression members shall be braced in such a way that the equivalent radius of gyration, r_e , shall be at least equal to the radius of gyration used in the column strength formula in Article 7.10.2.

C7.11.5.4

In the terminology of the aluminum industry, crimping is often referred to as “joggling.”

C7.12.1

Torsion may be categorized as:

- Pure torsion, or St. Venant's torsion, and
- Warping torsion.

Pure torsion produces only shear stress, but warping torsion produces both shear stress and bending stress.

7.12.2.1—Members with Double-Axis Symmetry

The equivalent radius of gyration, r_e , shall be taken as:

$$r_e = \left[\frac{C}{I_p} + \frac{GJ}{EI_p} \frac{L^2}{\pi^2} \right]^{\frac{1}{2}} \quad (7.12.2.1-1)$$

where:

G = shear modulus of elasticity (ksi)

J = St. Venant torsional inertia specified in Articles 7.12.3.1 and 7.12.3.2 (in.⁴)

C = warping torsion constant specified in Article 7.12.4

I_p = polar moment of inertia referred to the shear center (in.⁴)

L = distance between bracing points (in.)

7.12.2.2—Members with Single-Axis Symmetry

The equivalent radius of gyration, r_e , shall be taken as:

$$\frac{1}{r_e^2} = \frac{1}{2} \left(\frac{1}{r_\beta^2} + \frac{1}{r_y^2} \right) + \left[\frac{1}{4} \left(\frac{1}{r_\beta^2} - \frac{1}{r_y^2} \right)^2 + \left(\frac{y_o}{r_\beta r_y r_p} \right)^2 \right]^{\frac{1}{2}} \quad (7.12.2.2-1)$$

where:

r_y = radius of gyration for axis of symmetry (in.)

r_p = polar radius of gyration about the shear center (in.)

y_o = distance from the shear center of section to the center of gravity (in.)

r_β = r_e specified in Article 7.12.2.1

7.12.3—St. Venant Torsion

7.12.3.1—Open Section

The torsional inertia, J , for an open section may be taken as:

- If $\frac{b}{t} \geq 2$, then:

$$J = \sum \left(\frac{1}{3} \right) b t^3 \left(1 - 0.63 \frac{t}{b} \right) \quad (7.12.3.1-1)$$

- If $1 \leq \left(\frac{b}{t} \right) < 2$, then:

$$J = \sum \left[-0.044 + 0.235 \left(\frac{b}{t} \right) - 0.05 \left(\frac{b}{t} \right)^2 \right] b t^3 \quad (7.12.3.1-2)$$

where:

b = width of the rectangular plate element (in.)

t = thickness of the plate (in.)

7.12.3.2—Box Section

The torsional inertia, J , for a box section may be taken as:

$$J = 4 \frac{A^2}{\sum \frac{b}{t}} \quad (7.12.3.2-1)$$

where:

A = area enclosed by the plate of the box section (in.²)

b = width of rectangular plate element (in.)

t = thickness of plate (in.)

7.12.4—Warping Torsion

7.12.4.1—Open Sections

The warping constant, C , for an open section with double-axis symmetry may be taken as:

$$C = \left(\frac{1}{4} \right) I_y h^2 \quad (7.12.4.1-1)$$

The warping constant, C , for an open section with single-axis symmetry may be taken as:

$$C = \frac{h^2 I_1 I_2}{(I_1 + I_2)} \quad (7.12.4.1-2)$$

where:

I_y = moment of inertia about minor axis (in.⁴)

$I_1, I_2 =$ moment of inertial of the upper and lower flange, respectively, about the y-axis taken as the axis of symmetry (in.⁴)

$h =$ depth of section taken between mid thickness of flanges (in.)

7.12.4.2—Box Section

The warping constant, C , for a closed box section shall be taken to be equal to 0.0.

C7.12.4.2

Box sections are torsionally stiff.

7.13—COMBINED FORCE EFFECTS

7.13.1—Combined Compression and Flexure

A component subjected to axial compression and flexure due to lateral and/or eccentric loads shall satisfy Eqs. 7.13.1-1 and 7.13.1-2:

$$\frac{f_a}{F_a} + \frac{f_{2b}\delta_b + f_{2s}\delta_s}{F_b} \leq 1.0 \quad (7.13.1-1)$$

$$\frac{f_a}{F_a} + \frac{f_b}{F_b} \leq 1.0 \quad (7.13.1-2)$$

where:

$f_a =$ factored average compressive stress on cross-section (ksi)

$f_b =$ factored maximum compressive bending stress (ksi)

$F_a =$ factored resistance in terms of stress, F_r , for components subjected to compression only (ksi)

$F_b =$ factored flexural resistance in terms of stress, F_r , for components subjected to flexure only (ksi)

$\delta_b, \delta_s =$ moment magnification factors specified in Article 4.5.3.2.2b

$f_{2b}, f_{2s} =$ factored end stresses specified in Article 4.5.3.2.2b (ksi)

7.13.2—Combined Shear, Compression, and Flexure

Combinations of shear, compression, and flexure in the web of a beam column or in the wall of a tube shall satisfy:

$$\frac{f_a}{F_a} + \left(\frac{f_b}{F_b}\right)^n + \left(\frac{f_s}{F_s}\right)^2 \leq 1.0 \quad (7.13.2-1)$$

where:

f_a = factored average compressive stress (ksi)

F_a = factored resistance in terms of stress, F_r , for components subjected to compression only (ksi)

f_b = maximum factored compressive bending stress (ksi)

F_b = factored flexural resistance in terms of stress, F_r , for components subjected to flexure only (ksi)

f_s = factored shear stress due to torsion and shear (ksi)

F_s = factored resistance in terms of stress, F_r , for component subjected only to torsion or shear (ksi)

n = 1.0 for curved walls or round tubular members or 2.0 for webs of rectilinear shapes and plates of built-up beams

7.13.3—Torsion and Shear in Tubes

Factored resistance of round or oval tubes due to torsion and/or shear shall be determined in accordance with the provisions of Article 7.11.4.1, with the ratio h/t replaced by an equivalent h/t taken as:

$$\left(\frac{h}{t}\right)_{\text{equiv.}} = 2.9 \left(\frac{R}{t}\right)^{\frac{5}{8}} \left(\frac{L_t}{R}\right)^{\frac{1}{4}} \quad (7.13.3-1)$$

where:

R = outside radius of round tube or maximum outside radius of oval tube (in.)

t = thickness of tube (in.)

L_t = length of tube between circumferential stiffeners (in.)

7.13.4—Combined Compression and Flexure—Webs

Combinations of compression and flexure in the web of a beam shall satisfy:

$$\left(\frac{f_b}{F_b}\right)^{1.5} + \left(\frac{f_a}{F_a}\right)^{1.5} \leq 1 \quad (7.13.4-1)$$

where:

f_b = factored maximum compressive flexural stress (ksi)

F_b = factored flexural resistance in terms of stress, F_r , for components subjected to flexure only (ksi)

f_u = factored axial stress (ksi)

F_a = factored axial resistance in terms of stress per web for component subjected only to axial forces (ksi)

7.14—CONNECTIONS AND SPLICES

7.14.1—General

Bolted joints in aluminum shall be designed as bearing-type connections.

In proportioning aluminum fasteners, the effective diameter of rivets shall be taken as the lesser of the hole diameter or 104 percent of the nominal rivet diameter, and the effective diameter of bolts shall be taken as the nominal diameter.

All bolts shall have single self-locking nuts or double nuts and hardened washers placed under the turned elements.

Bolt threads shall be excluded from the shear planes of the contact surfaces between the connected parts. In determining whether the bolt threads are excluded from the shear planes, the thread length of bolts shall be calculated as two thread lengths greater than the specified thread length.

Rivets and bolts subjected to calculated stress and having a grip in excess of 4.5 diameters shall be increased in number by a factor of $[1/2 + G/(9d)]$, where G is the grip and d the nominal diameter of the rivet or bolt.

7.14.2—Bolted Connections

7.14.2.1—Bolts and Nuts

Bolt assemblies shall be galvanized according to requirements of AASHTO M 164 (ASTM A325) or cadmium coated. The nuts shall be heavy hexagonal nuts. The grade and finish of the nuts for each type of galvanized bolt shall be as specified in Table 7.14.2.1-1:

Table 7.14.2.1-1—Grade and Finish of Nuts

Bolt Type	Nut, Specification Grade, and Finish
M 164	M 291
1 and 2 Galvanized	Hot-Dipped Galvanized

C7.14.1

Aluminum fasteners are proportioned by using an “effective” diameter equal to the hole diameter, i.e., nominal diameter, plus four percent maximum, for rivets or the nominal diameter for bolts. This differentiation for aluminum rivets is based upon the need for the rivet to completely fill the hole in order to be effective in bearing.

The two thread lengths are specified as an allowance for thread run out.

7.14.2.2—Holes

Hole diameter shall not exceed the nominal bolt diameter by more than 0.0625 in.

The factored resistance of slotted holes shall be taken as two-thirds of the factored bearing resistance.

Oversize holes, short-slotted holes, long-slotted holes, and enlarged holes should be avoided. If slotted holes for bolts are necessary, approval of the Engineer shall be required. Oversize or slotted holes for riveted construction shall not be permitted.

7.14.2.3—Size of Fasteners

Fasteners less than 0.1875 in. diameter shall not be used.

7.14.2.4—Spacing of Fasteners*7.14.2.4.1—Minimum Pitch and Clear Distance**C7.14.2.4.1*

The distance between centers of fasteners shall not be less than 2.5 times the diameter of the fastener. The clear distance between holes shall not be less than the bolt diameter.

The minimum distance for rivet centers is 3 times the nominal rivet diameter versus 3.5 times for steel bolts, but the minimum distance for bolt centers is 2.5 times the nominal bolt diameter (*Aluminum Association, 1994*).

*7.14.2.4.2—Maximum Pitch for Sealing Fasteners**C7.14.2.4.2*

For sealing bolts, the pitch on a single line adjacent to a free edge of an outside plate or shape shall satisfy:

Pitch values for aluminum are approximately 70 percent of those for steel.

$$p \leq 3.0 + 3.0t \leq 5.0 \quad (7.14.2.4.2-1)$$

If there is a second line of fasteners uniformly staggered with those in the line adjacent to the free edge, at a gage less than $(1.0 + 3.0t)$ there from, the staggered pitch, p , in two such lines, considered together shall satisfy:

$$p \leq 3.0 + 3.0t - 0.75g \leq 5.0 \quad (7.14.2.4.2-2)$$

The staggered pitch need not be less than one-half the requirement for a single line.

where:

t = thickness of the thinner outside plate or shape (in.)

g = gage between fasteners (in.)

7.14.2.4.3—Maximum Pitch for Stitch Fasteners

In compression members, the pitch of stitch fasteners on any single line in the direction of stress shall not exceed $8.5t$ in. except that, if the fasteners on adjacent lines are staggered and the gage, g , between the line under consideration and the farther adjacent line is less than $17t$ in., the staggered pitch in the two lines, considered together, shall satisfy:

$$p \leq 10.0t - 0.375g \leq 8.5t \quad (7.14.2.4.3-1)$$

The gage between adjacent lines of fasteners shall not exceed $17t$ in.

In tension members, the pitch shall not exceed twice that specified for compression members, and the gage shall not exceed that specified for compression members.

7.14.2.4.4—Stitch Fasteners at the End of Compression Members

In built-up members, the factored compressive resistance in the direction of stress shall not be greater than the resistance determined by treating outside sheets and shapes as columns having a length equal to the pitch of the fasteners.

7.14.2.4.5—End and Edge Distances

The distance from the center of any fastener to a sheared, sawed, or extruded end shall not be less than 2.0 times the hole diameter. The distance from any edge shall not exceed either 5.5 times the thickness of the thinnest outside plate or 3.5 in. The distance from the center of any fastener to a sheared, sawed, or extruded edge shall not be less than 1.5 times the hole diameter.

7.14.2.5—Shear Resistance of Fasteners

The shear strength of aluminum fasteners shall be determined in the same manner as specified in Article 6.13.2.7 for steel fasteners, but the value of tensile strength, F_{tu} shall be taken as specified in Table 7.14.2.5-1:

Table 7.14.2.5-1—Values of Bolt Tensile Strength

Alloy	F_{tu} (ksi)
6061-T6	42.0
7075-T73	68.0

The shear strength of stainless steel fasteners shall be determined in the same manner as for steel fasteners, but the value of F_{tu} shall be equal to that stated for F_m in the *ASCE Standard Specification for the Design of Cold-Formed Stainless Steel Structural Members*.

C7.14.2.4.3

In built-up members where two or more plates or shapes are in contact, stitch fasteners should be used to ensure uniform action and, in compression members, to prevent buckling.

7.14.2.6—Slip-Critical Connections

Slip-critical connections shall not be used in aluminum components.

7.14.2.7—Bearing Resistance at Fastener Holes*7.14.2.7.1—General*

The effective bearing area of a fastener shall be its effective diameter multiplied by the thickness of the metal on which it bears. In elements less than 0.375 in. thick, countersunk rivets or turned and fitted bolts shall not be assumed to carry stress. In elements 0.375 in. thick and greater, one-half the depth of countersink shall be omitted in determining the bearing area.

7.14.2.7.2—Bearing Resistance at Rivet and Bolt Holes

When the ratio of edge distance to fastener diameter is not less than 2.0, the factored resistance in terms of bearing stress shall be taken as the lesser of the values given by either Eq. 7.14.2.7.2-1 or Eq. 7.14.2.7.2-2.

$$F_r = \phi_y F_{by} \quad (7.14.2.7.2-1)$$

$$F_r = \phi_u \frac{F_{bu}}{1.2} \quad (7.14.2.7.2-2)$$

where:

F_{bu} = bearing strength specified in Table 7.4.2.1-1 (ksi)

F_{by} = bearing yield stress specified in Table 7.4.2.1-1 (ksi)

ϕ_y, ϕ_u = resistance factor specified in Table 7.5.4-1

For edge distance to diameter ratios smaller than 2.0, the resistance stress calculated on the basis of Eqs. 7.14.2.7.2-1 and 7.14.2.7.2-2 shall be multiplied by the ratio of the edge distance to twice the fastener diameter.

7.14.2.7.3—Bearing on Flat Surfaces and Pins

The factored resistance in bearing of flat surfaces and pins shall be taken as two-thirds of that for fasteners as specified in Article 7.14.2.7.2.

7.14.2.8—Tension

The resistance of high-strength bolts in direct tension shall be determined on the basis of nominal bolt area and shall be taken as independent of any initial tightening force. Any tension resulting from prying action produced by deformation of the connected parts shall be added to the direct tensile force.

The factored resistance of the bolts shall be taken as:

$$P_r = \phi_u 0.75 A_b F_u \quad (7.14.2.8-1)$$

where:

P_r = factored tensile resistance (kip)

ϕ_u = resistance factor taken from Table 7.5.4-1

A_b = nominal bolt area (in.²)

F_u = nominal tensile strength of a fastener as specified in Table 7.14.2.5-1 (ksi)

7.14.3—Block Shear or End Rupture

The provisions of Article 6.13.4 shall apply, except that the net section that includes staggered holes in the cut shall be computed in accordance with the provisions of Article 7.9.4. In Eq. 6.13.4-1, all occurrences of F_y and F_u shall be replaced with F_{ty} and F_{tu} , respectively.

7.14.4—Splices

7.14.4.1—General

The resistance of members connected by high-strength bolts shall be determined using:

- The gross cross-section for compression members, and
- The net section specified in Articles 7.11.1.1 and 7.9.4 for tension components, flexural components, and splice material.

Bolted flange angle splices shall include two angles, one on each side of the flexural component. The provisions of Article 6.13.1 shall apply.

7.14.4.2—Tension Members

For determining the net cross-section and the resistance, the provisions of Article 7.9.4 shall apply.

7.14.4.3—Compression Members

The provisions of Article 6.13.6.1.3 shall apply.

7.14.4.4—Flexural Members

The provisions of Articles 6.13.6.1.4b and 6.13.6.1.4c shall apply.

7.14.4.5—Welding

Welded splice design and details shall conform to the requirements of the latest edition of the *ANSI/AWS Structural Welding Code—Aluminum D1.2* and the following provisions:

- Tension and compression members may be spliced by full penetration butt welds. Splice plates should be used.
- Welded field splices should be arranged to minimize overhead welding.
- In welded splices, any filler plate not less than 0.25 in. in thickness shall extend beyond the edges of the splice plate and shall be welded to the part on which it is fitted, with weld to transmit the splice plate force effects applied at the surface of the filler as an eccentric load.
- Filler plates less than 0.25 in. in thickness shall not be considered to transfer force effects. These plates shall be kept flush with the welded edges of the load-carrying part.

7.15—PROVISIONS FOR STRUCTURE TYPES

7.15.1—Floor System

The provisions of this Article shall apply to components of aluminum superstructures other than orthotropic deck systems. The provisions of Article 9.8.4 shall apply to aluminum orthotropic deck systems.

7.15.2—Lateral Bracing

Floorbeam connections shall be located so that the lateral bracing system will engage both the floorbeam and the main supporting members. Where the lateral bracing system intersects a joint formed by a floorbeam and a main longitudinal member, the lateral shall be rigidly connected to both members.

7.15.3—Beam and Girder Framing

For skew bridges, end cross-frames or diaphragms shall be placed along the skew line. Where the skew angle exceeds 20°, all interior cross-frames or diaphragms shall be placed at the right angle to beams or girders.

7.15.4—Trusses

7.15.4.1—General

The following Articles of Section 6 shall apply:

- Article 6.14.2.1—General

C7.15.4.1

Chord and web truss members can be extruded in a variety of shapes due to the versatility of the extrusion process. Such shapes can take the place of shapes built up from plate and sheet.

- Article 6.14.2.2—Truss Members
- Article 6.14.2.3—Secondary Stresses
- Article 6.14.2.4—Diaphragms
- Article 6.14.2.5—Camber
- Article 6.14.2.6—Working Lines and Gravity Axes
- Article 6.14.2.8—Gusset Plates, except that if the length of the unsupported edge of a gusset plate exceeds the value of $2.06 (E/F_{cy})^{0.5}$ times its thickness, the edge shall be stiffened.

Elements of individual truss members may be connected by welds, rivets, or bolts.

7.15.4.2—Portal and Sway Bracing

The provisions of Article 6.14.2.7 shall apply with the following additions:

- Through-truss spans shall have sway bracing of not less than 5.0 ft deep at each intermediate panel point;
- Top lateral struts shall be at least as deep as the top chord;
- Deck truss spans shall have sway bracing in the plane of the end posts and at all intermediate panel points;
- The point of support shall be the inner line of fasteners or fillet welds connecting the perforated plate to the flanges;
- For plate butt welded to the flange edge of segments, the point of support may be taken as the weld wherever the ratio of the outstanding flange width to flange thickness of the extruded segment is less than 7.0;
- Unless otherwise specified, the point of support shall be the root of the flange of the segment; and
- The periphery of the perforation at all points shall have a minimum radius of 1.5 in.

7.15.5—Arches

Provisions of Article 6.14.4 for steel arch structures shall apply for design of aluminum arch structures, except that plate slenderness shall comply with the provisions of Articles 7.10 and 7.11, as applicable.

7.16—REFERENCES

AA. 1993. *Aluminum Standards and Data*. The Aluminum Association, Inc., Washington, DC, p. 214.

AA. 1994. *Specifications for Aluminum Structures*, 6th Edition. The Aluminum Association, Inc., Washington, DC, December 1994.

ASCE. 1969. "Guide for the Design of Aluminum Formed Sheet Building Sheathing." *Journal of the Structural Division*, American Society of Civil Engineers, New York, NY, Vol. 95, No. ST8, August 1969, pp. 1727–1742.

ASCE. 1990. *Standard Specification for the Design of Cold-Formed Stainless Steel Structural Members*. American Society of Civil Engineers, New York, NY.

AWS. 2003. *Structural Welding Code: Aluminum*, ANSI/AWS D1.2/D1.2M:2003. American Welding Society, Miami, FL.

Kosteas, D and U. Graf. 1984. *Estimation and Statistical Evaluation of da/dN Data in Aluminum Weldments*, Report DFGKO 583-21. Technical University of Munich.

SECTION 8: WOOD STRUCTURES

TABLE OF CONTENTS

8.1—SCOPE 8-1

8.2—DEFINITIONS 8-1

8.3—NOTATION 8-4

8.4—MATERIALS 8-5

 8.4.1—Wood Products 8-5

 8.4.1.1—Sawn Lumber 8-5

 8.4.1.1.1—General 8-5

 8.4.1.1.2—Dimensions 8-6

 8.4.1.1.3—Moisture Content 8-6

 8.4.1.1.4—Reference Design Values 8-6

 8.4.1.2—Structural Glued Laminated Timber (Glulam) 8-12

 8.4.1.2.1—General 8-12

 8.4.1.2.2—Dimensions 8-13

 8.4.1.2.3—Reference Design Values 8-14

 8.4.1.3—Tension-Reinforced Glulams 8-18

 8.4.1.3.1—General 8-18

 8.4.1.3.2—Dimensions 8-18

 8.4.1.3.3—Fatigue 8-19

 8.4.1.3.4—Reference Design Values for Tension-Reinforced Glulams 8-19

 8.4.1.3.5—Volume Effect 8-20

 8.4.1.3.6—Preservative Treatment 8-21

 8.4.1.4—Piles 8-21

 8.4.2—Metal Fasteners and Hardware 8-21

 8.4.2.1—General 8-21

 8.4.2.2—Minimum Requirements 8-21

 8.4.2.2.1—Fasteners 8-21

 8.4.2.2.2—Prestressing Bars 8-21

 8.4.2.2.3—Split Ring Connectors 8-22

 8.4.2.2.4—Shear Plate Connectors 8-22

 8.4.2.2.5—Nails and Spikes 8-22

 8.4.2.2.6—Drift Pins and Bolts 8-22

 8.4.2.2.7—Spike Grids 8-22

 8.4.2.2.8—Toothed Metal Plate Connectors 8-22

 8.4.2.3—Corrosion Protection 8-23

 8.4.2.3.1—Metallic Coating 8-23

 8.4.2.3.2—Alternative Coating 8-23

 8.4.3—Preservative Treatment 8-23

 8.4.3.1—Requirement for Treatment 8-23

 8.4.3.2—Treatment Chemicals 8-23

 8.4.3.3—Inspection and Marking 8-24

 8.4.3.4—Fire Retardant Treatment 8-24

 8.4.4—Adjustment Factors for Reference Design Values 8-24

8.4.4.1—General.....	8-24
8.4.4.2—Format Conversion Factor, C_{KF}	8-25
8.4.4.3—Wet Service Factor, C_M	8-26
8.4.4.4—Size Factor, C_F , for Sawn Lumber	8-26
8.4.4.5—Volume Factor, C_V , (Glulam).....	8-27
8.4.4.6—Flat-Use Factor, C_{fu}	8-28
8.4.4.7—Incising Factor, C_i	8-29
8.4.4.8—Deck Factor, C_d	8-29
8.4.4.9—Time Effect Factor, C_λ	8-30
8.5—LIMIT STATES	8-30
8.5.1—Service Limit State	8-30
8.5.2—Strength Limit State	8-30
8.5.2.1—General.....	8-30
8.5.2.2—Resistance Factors.....	8-31
8.5.2.3—Stability	8-31
8.5.3—Extreme Event Limit State	8-31
8.6—COMPONENTS IN FLEXURE.....	8-31
8.6.1—General.....	8-31
8.6.2—Rectangular Section.....	8-31
8.6.3—Circular Section.....	8-33
8.7—COMPONENTS UNDER SHEAR	8-33
8.8—COMPONENTS IN COMPRESSION	8-33
8.8.1—General.....	8-33
8.8.2—Compression Parallel to Grain.....	8-33
8.8.3—Compression Perpendicular to Grain.....	8-34
8.9—COMPONENTS IN TENSION PARALLEL TO GRAIN	8-35
8.10—COMPONENTS IN COMBINED FLEXURE AND AXIAL LOADING	8-35
8.10.1—Components in Combined Flexure and Tension.....	8-35
8.10.2—Components in Combined Flexure and Compression Parallel to Grain	8-36
8.11—BRACING REQUIREMENTS	8-36
8.11.1—General.....	8-36
8.11.2—Sawn Wood Beams	8-36
8.11.3—Glued Laminated Timber Girders.....	8-37
8.11.4—Bracing of Trusses.....	8-37
8.12—CAMBER REQUIREMENTS	8-37
8.12.1—Glued Laminated Timber Girders.....	8-37
8.12.2—Trusses	8-37
8.12.3—Stress Laminated Timber Deck Bridge.....	8-37

8.13—CONNECTION DESIGN	8-37
8.14—REFERENCES.....	8-37

SECTION 8

WOOD STRUCTURES

8.1—SCOPE

This Section specifies design requirements for structural components made of sawn lumber products, stressed wood, glued laminated timber, wood piles, and mechanical connections.

8.2—DEFINITIONS

Adjusted Design Value—Reference design value multiplied by applicable adjustment factors.

Beams and Stringers (B&S)—Beams and stringers are rectangular pieces that are 5.0 or more in. thick (nominal), with a depth more than 2.0 in. (nominal) greater than the thickness. B&S are graded primarily for use as beams, with loads applied to the narrow face.

Bent—A type of pier consisting of two or more columns or column-like components connected at their top ends by a cap, strut, or other component holding them in their correct positions.

Bonded Reinforcement—A reinforcing material that is continuously attached to a glulam beam through adhesive bonding.

Bumper Lamination—A sacrificial wood lamination continuously bonded to the outer face of reinforcement to protect the reinforcement from damage, fire, or for visual appearance. The bumper lam is an option, not a requirement.

Cap—A sawn lumber or glulam component placed horizontally on an abutment or pier to distribute the live load and dead load of the superstructure. Also, a metal, wood, or mastic cover to protect exposed wood end grain from wetting.

Combination Symbol—A product designation used by the structural glued laminated timber industry; see AITC 117-2004.

Conventional Lamstock—Solid sawn wood laminations with a net thickness of 2.0 in. or less, graded either visually or through mechanical means, finger-jointed and face-bonded to form a glulam per ASTM D7199.

Crib—A structure consisting of a foundation grillage and a framework providing compartments that are filled with gravel, stones, or other material satisfactory for supporting the structure to be placed thereon.

Decking—A subcategory of dimension lumber, graded primarily for use with the wide face placed flatwise.

Delamination—Adhesive failure causing the separation of laminations.

Development Length—The length of the bond line along the axis of the beam required to develop the design tensile strength of the reinforcement.

Diaphragm—Blocking between two main longitudinal beams consisting of solid lumber, glued laminated timber, or steel cross bracing.

Dimension Lumber—Lumber with a nominal thickness of from 2.0 up to but not including 5.0 in. and having a nominal width of 2.0 in. or more.

Dowel—A relatively short length of round metal bar used to interconnect or attach two wood components in a manner to minimize movement and displacement.

Dressed Lumber—Lumber that has been surfaced by a planing machine on one or more sides or edges.

Dry—The condition of having a relatively low moisture content, i.e., not more than 19 percent for sawn lumber and 16 percent for glued laminated timber.

E-Glass—A low alkali (borosilicate glass) electrical grade glass fiber commonly used by the composite industry for the manufacture of FRP composites.

Fiber-Reinforced Polymer (FRP)—Any material consisting of at least two distinct components: reinforcing fibers and a binder matrix (a polymer). The reinforcing fibers are permitted to be either synthetic (e.g. glass), metallic, or natural (e.g. bamboo), and are permitted to be long and continuously-oriented or short and randomly oriented. The binder matrix is permitted to be either thermoplastic (e.g. polypropylene or nylon) or thermosetting (e.g. epoxy or vinyl-ester).

Frame Bent—A type of framed timber substructure.

Grade—The designation of the material quality of a manufactured piece of wood.

Grade Mark—The identification of lumber with symbols or lettering to certify its quality or grade.

Grain—The direction, size, arrangement, appearance, or quality of the fibers in wood or lumber.

Green Wood—A freshly sawn or undried wood. Wood that has become completely wet after immersion in water would not be considered green but may be said to be in the green condition.

Hardwood—Generally one of the botanical groups of trees that have broad leaves or the wood produced by such trees. The term has no reference to the actual hardness of the wood.

Horizontally Laminated Timber—Laminated wood in which the laminations are arranged with their wider dimension approximately perpendicular to the direction of applied transverse loads.

Laminate—A product made by bonding together two or more layers (laminations) of material or materials.

Laminated Wood—An assembly made by bonding layers of veneer or lumber with an adhesive, nails, or stressing to provide a structural continuum so that the grain of all laminations is essentially parallel.

Laminating—The process of bonding laminations together with adhesive, including the preparation of the laminations, preparation and spreading of adhesive, assembly of laminations in packages, application of pressure, and curing.

Lamination—A full width and full length layer contained in a component bonded together with adhesive. The layer itself may be composed of one or several wood pieces in width or length.

Machine Evaluated Lumber (MEL)—Mechanically graded lumber certified as meeting the criteria of a specific commercial grading system.

Machine Stress Rated (MSR) Lumber—Mechanically graded lumber certified as meeting the criteria of a specific commercial grading system.

Mechanically Graded Lumber—Solid sawn lumber graded by mechanical evaluation in addition to visual examination.

Modulus of Rupture (MOR)—The maximum stress at the extreme fiber in bending, calculated from the maximum bending moment on the basis of an assumed stress distribution.

Moisture Content—An indication of the amount of water contained in the wood, usually expressed as a percentage of the weight of the oven dry wood.

NDS[®]—*National Design Specification*[®] for Wood Construction by the American Forest and Paper Association.

NELMA—Grading rules by Northeastern Lumber Manufacturers Association.

NLGA—Grading rules by National Lumber Grades Authority.

Net Size—The size used in design to calculate the resistance of a component. Net size is close to the actual dry size.

Nominal Size—As applied to timber or lumber, the size by which it is specified and sold; often differs from the actual size.

NSLB—Grading rules by Northern Softwood Lumber Bureau.

Oil-Borne Preservative—A preservative that is introduced into wood in the form of an oil-based solution.

Plank—A broad board, usually more than 1.0 in. thick, laid with its wide dimension horizontal and used as a bearing surface or riding surface.

Posts and Timber (P&T)—Posts and timbers pieces with a square or nearly square cross-section, 5.0 by 5.0 in. (nominal) and larger, with the width not more than 2.0 in. (nominal) greater than the thickness. Lumber in the P&T size classification is graded primarily for resisting axial loads.

Preservative—Any substance that is effective in preventing the development and action of wood-decaying fungi, borers of various kinds, and harmful insects.

Reinforcement (for Glulam)—Any material that is not a conventional lamstock lumber whose mean (ultimate) longitudinal unit strength exceeds 20 ksi for tension and compression, and whose mean tension and compression modulus of elasticity exceeds 3,000 ksi. Acceptable reinforcing materials include but are not restricted to: Fiber-Reinforced Polymer (FRP) plates and bars, and metallic plates and bars.

Reference Design Value—The allowable stress value or modulus of elasticity specified in the *NDS*[®].

Rough Sawn Lumber—Lumber that has not been dressed but that has been sawn, edged, and trimmed.

Sawn Lumber—The product of a sawmill not further manufactured other than by sawing, resawing, passing lengthwise through a standard planing mill, drying, and cross-cutting to length.

Sawn Timbers—Lumber that is nominally 5.0 in. or more in least dimension.

Softwood—Generally, one of the conifers or the wood produced by such trees. The term has no reference to the actual hardness of the wood.

SPIB—Grading rules by Southern Pine Inspection Bureau.

Stress Grades—Lumber grades having assigned working stress and modulus of elasticity in accordance with accepted principles of resistance grading.

Structural Glued Laminated Timber (glulam)—An engineered, stress-rated product of a timber laminating plant comprised of assemblies of specially selected and prepared wood laminations securely bonded together with adhesives. The grain of all laminations is approximately parallel longitudinally. Glued laminated timber is permitted to be comprised of pieces end joined to form any length, of pieces placed or bonded edge to edge to make any width, or of pieces bent to curved form during bonding.

Structural Lumber—Lumber that has been graded and assigned design values based on standardized procedures to ensure acceptable reliability.

Tension Reinforcement—Reinforcement placed on the tension side of a flexural member on the first glue-line or on the face of the beam.

Vertically Laminated Timber—Laminated wood in which the laminations are arranged with their wider dimension approximately parallel to the direction of load.

Visually Graded Lumber—Structural lumber graded solely by visual examination.

Waterborne Preservative—A preservative that is introduced into wood in the form of a water-based solution.

WCLIB—Grading rules by West Coast Lumber Inspection Bureau.

Wet-Use—Use conditions where the moisture content of the wood in service exceeds 16 percent for glulam and 19 percent for sawn lumber.

WWPA—Grading rules by Western Wood Products Association.

8.3—NOTATION

A	=	parameter for beam stability (8.6.2)
A_b	=	bearing area (in. ²) (8.8.3)
A_g	=	gross cross-sectional area of the component (in. ²) (8.8.2)
A_n	=	net cross-sectional area of the component (in. ²) (8.9)
a	=	coefficient (8.4.4.5)
B	=	parameter for compression (8.8.2)
b	=	width of the glued laminated timber component; thickness of lumber component (see Figure 8.3-1) (in.) (8.4.4.5)
C_b	=	bearing factor (8.8.3)
C_c	=	curvature factor (8.4.1.2)
C_d	=	deck factor (8.4.4.8)
C_F	=	size factor (8.4.4.4)
C_{fu}	=	flat use factor (8.4.4.6)
C_i	=	incising factor (8.4.4.7)
C_{KF}	=	format conversion factor (8.4.4.2)
C_L	=	beam stability factor (8.6.2)
C_M	=	wet service factor (8.4.4.3)
C_P	=	column stability factor (8.8.2)
C_V	=	volume factor (8.4.4.5)
C_λ	=	time effect factor (8.4.4.9)
d	=	depth of the beams or stringers or width of the dimension lumber component (8.4.4.4) or glulam depth (8.4.4.5) as shown in Figure 8.3-1 (in.)
E	=	adjusted modulus of elasticity (ksi) (8.4.4.1)
E_o	=	reference modulus of elasticity (ksi) (8.4.1.1.4)
F	=	adjusted design value (ksi) (8.4.4.1)
F_b	=	adjusted design value in flexure (ksi) (8.4.4.1)
F_{bo}	=	reference design value of wood in flexure (ksi) (8.4.1.1.4)
F_c	=	adjusted design value of wood in compression parallel to grain (ksi) (8.4.4.1)
F_{co}	=	reference design value of wood in compression parallel to grain (ksi) (8.4.1.1.4)
F_{cp}	=	adjusted design value of wood in compression perpendicular to grain (ksi) (8.4.4.1)
F_{cpo}	=	reference design value of wood in compression perpendicular to grain (ksi) (8.4.1.1.4)
F_o	=	reference design value (ksi) (8.4.4.1)
F_t	=	adjusted design value of wood in tension (ksi) (8.4.4.1)
F_{to}	=	reference design value of wood in tension (ksi) (8.4.1.1.4)
F_v	=	adjusted design value of wood in shear (ksi) (8.4.4.1)
F_{vo}	=	reference design value of wood in shear (ksi) (8.4.1.1.4)
G	=	specific gravity (8.4.1.1.4)
K	=	effective buckling length factor (8.8.2)
L	=	length (ft) (8.4.4.5)
L_e	=	effective length (in.) (8.6.2)
L_u	=	laterally unsupported length of the component (in.) (8.6.2)
M_n	=	nominal flexural resistance (kip-in.) (8.6)
M_r	=	factored flexural resistance, ϕM_n (kip-in.) (8.6)
M_u	=	factored moment (kip-in.) (8.10)
P_n	=	nominal compression or tension resistance (kips) (8.8) (8.9)
P_r	=	factored axial resistance (kips) (8.8) (8.9)
P_u	=	factored axial load (kips) (8.10)
S	=	section modulus (in. ³) (8.6.2)
V_n	=	nominal shear resistance (kips) (8.7)
V_r	=	factored shear resistance, ϕV_n (kips) (8.7)
ϕ	=	resistance factor (8.5.2.2)

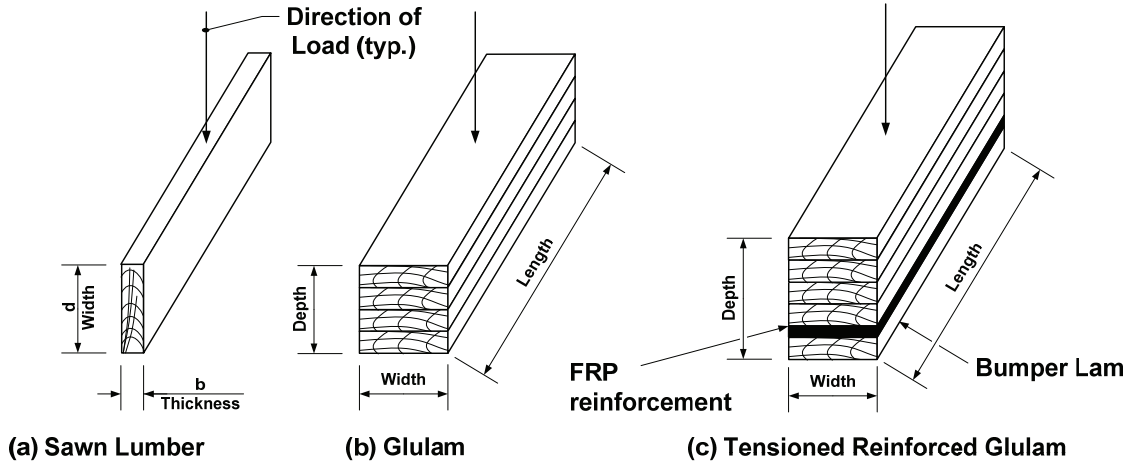

Figure 8.3-1—Dimensions as Defined for Various Types of Wood Products

8.4—MATERIALS

8.4.1—Wood Products

Nominal resistance for wood products shall be based on specified size and conditions of use with respect to moisture content and time effect. To obtain nominal resistance and stiffness values for design, the reference design values specified in Tables 8.4.1.1.4-1, 8.4.1.1.4-2, 8.4.1.1.4-3, 8.4.1.2.3-1, 8.4.1.2.3-2, 8.4.1.3.4-1, and 8.4.1.4-1 shall be adjusted for actual conditions of use in accordance with Article 8.4.4.

8.4.1.1—Sawn Lumber

8.4.1.1.1—General

Sawn lumber shall comply with the requirements of AASHTO M 168.

When solid sawn beams and stringers are used as continuous or cantilevered beams, the grading provisions applicable to the middle third of the length shall be applied to at least the middle two-thirds of the length of pieces to be used as two-span continuous beams and to the entire length of pieces to be used over three or more spans or as cantilevered beams.

C8.4.1

Reference design values are based on dry-use conditions, with the wood moisture content not exceeding 19 percent for sawn lumber and 16 percent for structural glued laminated timber. Reference design values are applied to material preservatively treated in accordance with AASHTO M 133.

Reference design values have been taken from the *National Design Specification® (NDS®) for Wood Construction*. The *NDS®* publishes reference values for allowable stress design (ASD) and provides format conversion factors for use of these values with the load and resistance factor design (LRFD) methodology. To facilitate the direct use of the values developed by the wood products industry and included in the *NDS®*, the same format has been adopted for AASHTO LRFD design.

Reference design values for tension-reinforced glulams have been developed following procedures in ASTM D7199 and AC 280 (ICC-ES).

8.4.1.1.2—Dimensions

Structural calculations shall be based on the actual net dimensions for the anticipated use conditions.

Dimensions stated for dressed lumber shall be the nominal dimensions. Net dimensions for dressed lumber shall be taken as 0.5 in. less than nominal, except that the net width of dimension lumber exceeding 6.0 in. shall be taken as 0.75 in. less than nominal.

For rough-sawn, full-sawn, or special sizes, the actual dimensions and moisture content used in design shall be indicated in the contract documents.

8.4.1.1.3—Moisture Content

The moisture content of dimension lumber shall not be greater than 19 percent at the time of installation.

8.4.1.1.4—Reference Design Values

Reference design values for visually graded sawn lumber shall be as specified in Table 8.1.1.4-1.

Reference design values for mechanically graded dimension lumber shall be as specified in Table 8.1.1.4-2.

Unless otherwise indicated, reference design value in flexure for dimension lumber and posts and timbers shall apply to material where the load is applied to either the narrow or wide face. Reference design value in flexure for decking grades shall apply only with the load applied to the wide face.

Values for specific gravity, G , shear parallel to grain, F_v , and compression perpendicular to grain, F_{cpo} , for mechanically graded dimension lumber shall be taken as specified in Table 8.1.1.4-3. For species or species groups not given in Table 8.1.1.4-3, the G , F_v , and F_{cpo} values for visually graded lumber may be used.

Reference design values for lumber grades not given in Table 8.1.1.4-1 and Table 8.1.1.4-2 shall be obtained from the *National Design Specification*[®] (*NDS*[®]) for *Wood Construction*.

Where the E_o or F_{to} values shown on a grade stamp differ from Table 8.1.1.4-2 values associated with the F_{bo} on the grade stamp, the values on the stamp shall be used in design, and the F_{co} value associated with the F_{bo} value in Table 8.1.1.4-2 shall be used.

For machine evaluated lumber (MEL) commercial grades M-17, M-20 and M-27, F_{co} , requires qualification and quality control shall be required.

C8.4.1.1.2

These net dimensions depend on the type of surfacing, whether dressed, rough-sawn, or full-sawn.

The designer should specify surface requirements on the plans. Rough-sawn lumber is typically 0.125 in. larger than standard dry dressed sizes, associated with the F_{bo} value in Table 8.4.1.1.4-2 and full-sawn lumber, which is not widely used, is cut to the same dimensions as the nominal size. In both of the latter cases, thickness and width dimensions are variable, depending on the sawmill equipment. Therefore, it is impractical to use rough-sawn or full-sawn lumber in a structure that requires close dimensional tolerances.

For more accurate dimensions, surfacing can be specified on one side (S1S), two sides (S2S), one edge (S1E), two edge (S2E), combinations of sides and edges (S1S1E, S2S1E, S1S2E) or all sides (S4S).

C8.4.1.1.4

In calculating design values in Table 8.1.1.4-2, the natural gain in strength and stiffness that occurs as lumber dries has been taken into consideration as well as the reduction in size that occurs when unseasoned lumber shrinks. The gain in load carrying capacity due to increased strength and stiffness resulting from drying more than offsets the design effect of size reductions due to shrinkage.

Reference design values specified in Table 8.1.1.4-2 shall be taken as applicable to lumber that will be used under dry conditions. For 2.0-in. to 4.0-in. thick lumber, the dry dressed sizes shall be used regardless of the moisture content at the time of manufacture or use.

For any given bending design value, F_{bo} , the modulus of elasticity, E_o , and tension parallel to grain, F_{to} , design value may vary depending upon species, timber source or other variables. The E_o and F_{to} values included in the F_{bo} - E_o grade designations in Table 8.1.1.4-2 are those usually associated with each F_{bo} level. Grade stamps may show higher or lower values if machine rating indicates the assignment is appropriate.

Higher G values may be claimed when (a) specifically assigned by the rules writing agency or (b) when qualified by test, quality controlled for G and provided for on the grade stamp. When a different G value is provided on the grade stamp, higher F_{vo} and F_{cpa} design values may be calculated in accordance with the grading rule requirements.

Table 8.4.1.1.4-1—Reference Design Values for Visually Graded Sawn Lumber

Species and Commercial Grade	Size Classification	Design Values (ksi)						Grading Rules Agency	
		Bending	Tension parallel to grain	Shear parallel to grain	Compression perpendicular to grain	Compression parallel to grain	Modulus of Elasticity		
		F_{bo}	F_{to}	F_{vo}	F_{cpo}	F_{co}	E_o		
Douglas Fir-Larch									
Select Structural	Dimension ≥ 2 in. Wide	1.50	1.00	0.18	0.625	1.70	1,900	WCLIB WWPA	
No. 1 & Btr		1.20	0.80	0.18	0.625	1.55	1,800		
No. 1		1.00	0.675	0.18	0.625	1.50	1,700		
No. 2		0.90	0.575	0.18	0.625	1.35	1,600		
Dense Select Structural	Beams and Stringers	1.90	1.10	0.17	0.73	1.30	1,700	WCLIB	
Select Structural		1.60	0.95	0.17	0.625	1.10	1,600		
Dense No. 1		1.55	0.775	0.17	0.73	1.10	1,700		
No. 1		1.35	0.675	0.17	0.625	0.92	1,600		
No. 2	0.875	0.425	0.17	0.625	0.60	1,300			
Dense Select Structural	Posts and Timbers	1.75	1.15	0.17	0.73	1.35	1,700		
Select Structural		1.50	1.00	0.17	0.625	1.15	1,600		
Dense No. 1		1.40	0.95	0.17	0.73	1.20	1,700		
No. 1		1.20	0.825	0.17	0.625	1.00	1,600		
No. 2	0.75	0.475	0.17	0.625	0.70	1,300			
Dense Select Structural	Beams and Stringers	1.90	1.10	0.17	0.73	1.30	1,700		WWPA
Select Structural		1.60	0.95	0.17	0.625	1.10	1,600		
Dense No. 1		1.55	0.775	0.17	0.73	1.10	1,700		
No. 1		1.35	0.675	0.17	0.625	0.925	1,600		
No. 2 Dense	1.00	0.50	0.17	0.73	0.70	1,400			
No. 2	0.875	0.425	0.17	0.625	0.60	1,300			
Dense Select Structural	Posts and Timbers	1.75	1.15	0.17	0.73	1.35	1,700		
Select Structural		1.50	1.00	0.17	0.625	1.15	1,600		
Dense No. 1		1.40	0.95	0.17	0.73	1.20	1,700		
No. 1		1.20	0.825	0.17	0.625	1.00	1,600		
No. 2 Dense	0.85	0.55	0.17	0.73	0.825	1,400			
No. 2	0.75	0.475	0.17	0.625	0.70	1,300			
Eastern Softwoods									
Select Structural	Dimension ≥ 2 in. Wide	1.25	0.575	0.14	0.335	1.20	1,200	NELMA NSLB	
No. 1		0.775	0.35	0.14	0.335	1.00	1,100		
No. 2		0.575	0.275	0.14	0.335	0.825	1,100		
Hem-Fir									
Select Structural	Dimension ≥ 2 in. Wide	1.40	0.925	0.15	0.405	1.50	1,600	WCLIB WWPA	
No. 1 & Btr		1.10	0.725	0.15	0.405	1.35	1,500		
No. 1		0.975	0.625	0.15	0.405	1.35	1,500		
No. 2		0.85	0.525	0.15	0.405	1.30	1,300		
Select Structural	Beams and Stringers	1.30	0.75	0.14	0.405	0.925	1,300		
No.1		1.05	0.525	0.14	0.405	0.75	1,300		
No.2		0.675	0.35	0.14	0.405	0.50	1,100		
Select Structural	Posts and Timbers	1.20	0.80	0.14	0.405	0.975	1,300		
No.1		0.975	0.65	0.14	0.405	0.85	1,300		
No.2		0.575	0.375	0.14	0.405	0.575	1,100		
Mixed Southern Pine									
Select Structural	Dimension 2 in.–4 in. Wide	2.05	1.20	0.175	0.565	1.80	1,600		SPIB
No.1		1.45	0.875	0.175	0.565	1.65	1,500		
No.2		1.30	0.775	0.175	0.565	1.65	1,400		
Select Structural	Dimension 5 in.–6 in. Wide	1.85	1.10	0.175	0.565	1.70	1,600		
No.1		1.30	0.75	0.175	0.565	1.55	1,500		
No.2		1.15	0.675	0.175	0.565	1.55	1,400		
Select Structural	Dimension 8 in. Wide	1.75	1.00	0.175	0.565	1.60	1,600		
No.1		1.20	0.70	0.175	0.565	1.45	1,500		
No.2		1.05	0.625	0.175	0.565	1.45	1,400		

Table 8.4.1.1.4-1 (continued)—Reference Design Values for Visually Graded Sawn Lumber

Species and Commercial Grade	Size Classification	Design Values (ksi)						Grading Rules Agency	
		Bending	Tension parallel to grain	Shear parallel to grain	Compression perpendicular to grain	Compression parallel to grain	Modulus of Elasticity		
		F_{bo}	F_{to}	F_{vo}	F_{cpo}	F_{co}	E_o		
Mixed Southern Pine (continued)									
No.2		1.05	0.625	0.175	0.565	1.45	1,400	SPIB	
Select Structural	Dimension 10 in. Wide	1.50	0.875	0.175	0.565	1.60	1,600		
No.1		1.05	0.60	0.175	0.565	1.45	1,500		
No.2		0.925	0.55	0.175	0.565	1.45	1,400		
Select Structural	Dimension 12 in. Wide	1.40	0.825	0.175	0.565	1.55	1,600		
No.1		0.975	0.575	0.175	0.565	1.40	1,500		
No.2		0.875	0.525	0.175	0.565	1.40	1,400		
Select Structural	5 in. × 5 in. and Larger	1.50	1.00	0.165	0.375	0.90	1,300		
No.1		1.35	0.90	0.165	0.375	0.80	1,300		
No.2		0.85	0.55	0.165	0.375	0.525	1,000		
Northern Red Oak									
Select Structural	Dimension ≥2 in. Wide	1.40	0.80	0.22	0.885	1.15	1,400		NELMA
No. 1		1.00	0.575	0.22	0.885	0.925	1,400		
No. 2		0.975	0.575	0.22	0.885	0.725	1,300		
Select Structural	Beams and Stringers	1.60	0.95	0.205	0.885	0.95	1,300		
No.1		1.35	0.675	0.205	0.885	0.80	1,300		
No.2		0.875	0.425	0.205	0.885	0.50	1,000		
Select Structural	Posts and Timbers	1.50	1.00	0.205	0.885	1.00	1,300		
No.1		1.20	0.80	0.205	0.885	0.875	1,300		
No.2		0.70	0.475	0.205	0.885	0.40	1,000		
Red Maple									
Select Structural	Dimension ≥2 in. Wide	1.30	0.75	0.21	0.615	1.10	1,700	NELMA	
No. 1		0.925	0.55	0.21	0.615	0.90	1,600		
No. 2		0.90	0.525	0.21	0.615	0.70	1,500		
Select Structural	Beams and Stringers	1.50	0.875	0.195	0.615	0.90	1,500		
No.1		1.25	0.625	0.195	0.615	0.75	1,500		
No.2		0.80	0.40	0.195	0.615	0.475	1,200		
Select Structural	Posts and Timbers	1.40	0.925	0.195	0.615	0.95	1,500		
No.1		1.15	0.75	0.195	0.615	0.825	1,500		
No.2		0.65	0.425	0.195	0.615	0.375	1,200		
Red Oak									
Select Structural	Dimension ≥2 in. Wide	1.15	0.675	0.17	0.82	1.00	1,400		NELMA
No. 1		0.825	0.50	0.17	0.82	0.825	1,300		
No. 2		0.80	0.475	0.17	0.82	0.625	1,200		
Select Structural	Beams and Stringers	1.35	0.80	0.155	0.82	0.825	1,200		
No.1		1.15	0.55	0.155	0.82	0.70	1,200		
No.2		0.725	0.375	0.155	0.82	0.45	1,000		
Select Structural	Posts and Timbers	1.25	0.85	0.155	0.82	0.875	1,200		
No.1		1.00	0.675	0.155	0.82	0.775	1,200		
No.2		0.575	0.40	0.155	0.82	0.35	1,000		

Table 8.4.1.1.4-1 (continued)—Reference Design Values for Visually Graded Sawn Lumber

Species and Commercial Grade	Size Classification	Design Values (ksi)						Grading Rules Agency
		Bending	Tension Parallel to Grain	Shear Parallel to Grain	Compression Perpendicular to Grain	Compression Parallel to Grain	Modulus of Elasticity	
		F_{bo}	F_{t0}	F_{v0}	F_{cp0}	F_{c0}	E_o	
Southern Pine								
Select Structural	Dimension 2 in.–4 in. Wide	2.85	1.60	0.175	0.565	2.10	1,800	SPIB
No.1		1.85	1.05	0.175	0.565	1.85	1,700	
No.2		1.50	0.825	0.175	0.565	1.65	1,600	
Select Structural	Dimension 5 in.–6 in. Wide	2.55	1.40	0.175	0.565	2.00	1,800	
No.1		1.65	0.90	0.175	0.565	1.75	1,700	
No.2		1.25	0.725	0.175	0.565	1.60	1,600	
Select Structural	Dimension 8 in. wide	2.30	1.30	0.175	0.565	1.90	1,800	
No.1		1.50	0.825	0.175	0.565	1.65	1,700	
No.2		1.20	0.65	0.175	0.565	1.55	1,600	
Select Structural	Dimension 10 in. Wide	2.05	1.10	0.175	0.565	1.85	1,800	
No.1		1.30	0.725	0.175	0.565	1.60	1,700	
No.2		1.05	0.575	0.175	0.565	1.50	1,600	
Select Structural	Dimension 12 in. Wide	1.90	1.05	0.175	0.565	1.80	1,800	
No.1		1.25	0.675	0.175	0.565	1.60	1,700	
No.2		0.975	0.55	0.175	0.565	1.45	1,600	
Select Structural	5 in. × 5 in. and Larger	1.50	1.00	0.165	0.375	0.95	1,500	
No. 1		1.35	0.90	0.165	0.375	0.825	1,500	
No. 2		0.85	0.55	0.165	0.375	0.525	1,200	
Spruce-Pine-Fir								
Select Structural	Dimension ≥2 in. Wide	1.25	0.70	0.135	0.425	1.40	1,500	NLGA
No. 1/ No. 2		0.875	0.45	0.135	0.425	1.15	1,400	
Select Structural	Beams and Stringers	1.10	0.65	0.125	0.425	0.775	1,300	
No.1		0.90	0.45	0.125	0.425	0.625	1,300	
No.2		0.60	0.30	0.125	0.425	0.425	1,000	
Select Structural	Posts and Timbers	1.05	0.70	0.125	0.425	0.80	1,300	
No.1		0.85	0.55	0.125	0.425	0.70	1,300	
No.2		0.50	0.325	0.125	0.425	0.50	1,000	
Spruce-Pine-Fir (South)								
Select Structural	Dimension ≥2 in. Wide	1.30	0.575	0.135	0.335	1.20	1,300	NELMA NSLB WCLIB WWPA
No. 1		0.875	0.40	0.135	0.335	1.05	1,200	
No. 2		0.775	0.35	0.135	0.335	1.00	1,100	
Select Structural	Beams and Stringers	1.05	0.625	0.125	0.335	0.675	1,200	
No.1		0.90	0.45	0.125	0.335	0.55	1,200	
No.2		0.575	0.30	0.125	0.335	0.375	1,000	
Select Structural	Posts and Timbers	1.00	0.675	0.125	0.335	0.70	1,200	
No.1		0.80	0.55	0.125	0.335	0.625	1,200	
No.2		0.475	0.325	0.125	0.335	0.425	1,000	
Yellow Poplar								
Select Structural	Dimension ≥2 in. Wide	1.00	0.575	0.145	0.42	0.90	1,500	NSLB
No. 1		0.725	0.425	0.145	0.42	0.725	1,400	
No. 2		0.70	0.40	0.145	0.42	0.575	1,300	

Table 8.4.1.1.4-2—Reference Design Values for Mechanically Graded Dimension Lumber

Commercial Grade	Size Classification	Design Values (ksi)				Grading Rules Agency
		Bending	Tension Parallel to Grain	Compression Parallel to Grain	Modulus of Elasticity	
		F_{bo}	F_{to}	F_{co}	E_o	
Machine Stress Rated (MSR) Lumber						
900f-1.0E	≤2 in. Thick ≥2 in. Wide	0.90	0.35	1.05	1,000	WCLIB, WWPA, NELMA, NSLB
1200f-1.2E		1.20	0.60	1.40	1,200	NLGA, WCLIB, WWPA, NELMA, NSLB
1250f-1.4E		1.25	0.80	1.475	1,400	WCLIB, WWPA
1350f-1.3E		1.35	0.75	1.60	1,300	NLGA, WCLIB, WWPA, NELMA, NSLB
1400f-1.2E		1.40	0.80	1.60	1,200	NLGA, WWPA
1450f-1.3E		1.45	0.80	1.625	1,300	NLGA, WCLIB, WWPA, NELMA, NSLB
1450f-1.5E		1.45	0.875	1.625	1,500	WCLIB, WWPA
1500f-1.4E		1.50	0.90	1.65	1,400	NLGA, WCLIB, WWPA, NELMA, NSLB
1600f-1.4E		1.60	0.95	1.675	1,400	NLGA, WWPA
1650f-1.3E		1.65	1.02	1.70	1,300	NLGA, WWPA
1650f-1.5E		1.65	1.02	1.70	1,500	NLGA, SPIB, WCLIB, WWPA, NELMA, NSLB
1650f-1.6E-1075 ft		1.65	1.075	1.70	1,600	WCLIB, WWPA
1650f-1.6E		1.65	1.175	1.70	1,600	WCLIB, WWPA
1650f-1.8E		1.65	1.02	1.75	1,800	WCLIB, WWPA
1700f-1.6E		1.70	1.175	1.725	1,600	WCLIB, WWPA
1750f-2.0E		1.75	1.125	1.725	2,000	WCLIB, WWPA
1800f-1.5E		1.80	1.30	1.75	1,500	NLGA, WWPA
1800f-1.6E		1.80	1.175	1.75	1,600	NLGA, SPIB, WCLIB, WWPA, NELMA, NSLB
1800f-1.8E		1.80	1.20	1.75	1,800	WCLIB, WWPA
1950f-1.5E		1.95	1.375	1.80	1,500	SPIB, WWPA
1950f-1.7E	1.95	1.375	1.80	1,700	NLGA, SPIB, WCLIB, WWPA, NELMA, NSLB	
2000f-1.6E	2.00	1.30	1.825	1,600	NLGA, WWPA	
2100f-1.8E	2.10	1.575	1.875	1,800	NLGA, SPIB, WCLIB, WWPA, NELMA, NSLB	
2250f-1.7E	2.25	1.75	1.925	1,700	NLGA, WWPA	
2250f-1.8E	2.25	1.75	1.925	1,800	NLGA, WCLIB, WWPA	
2250f-1.9E	2.25	1.75	1.925	1,900	NLGA, SPIB, WCLIB, WWPA, NELMA, NSLB	
2250f-2.0E-1600ft	2.25	1.60	1.925	2,000	WCLIB, WWPA	
2250f-2.0E	2.25	1.75	1.925	2,000	WCLIB, WWPA	
2400f-1.8E	2.40	1.925	1.975	1,800	NLGA, WWPA	
2400f-2.0E	2.40	1.925	1.975	2,000	NLGA, SPIB, WCLIB, WWPA, NELMA, NSLB	
2500f-2.2E	2.50	1.75	2.00	2,200	WCLIB, WWPA	
2500f-2.2E-1925ft	2.50	1.925	2.00	2,200	WCLIB, WWPA	
2550f-2.1E	2.55	2.05	2.025	2,100	NLGA, SPIB, WCLIB, WWPA, NELMA, NSLB	
2700f-2.0E	2.70	1.80	2.10	2,000	WCLIB, WWPA	
2700f-2.2E	2.70	2.15	2.10	2,200	NLGA, SPIB, WCLIB, WWPA, NELMA, NSLB	
2850f-2.3E	2.85	2.30	2.150	2,300	NLGA, SPIB, WCLIB, WWPA, NELMA, NSLB	
3000f-2.4E	3.00	2.40	2.20	2,400	NLGA, SPIB	
Machine Evaluated Lumber (MEL)						
M-5	≤2 in. Thick	0.90	0.500	1.05	1.100	SPIB
M-6	≤2 in. Thick	1.10	0.600	1.30	1.000	SPIB
M-7	≥2 in. Wide	1.20	0.650	1.40	1.100	SPIB

Table 8.4.1.1.4-3—Reference Design Values of Specific Gravity, G , Shear, F_{vo} , and Compression Perpendicular to Grain, F_{cpo} , for Mechanically Graded Dimension Lumber

Species	Modulus of Elasticity E (ksi)	Specific Gravity G	Design Values (ksi)		Grading Rules Agency
			Shear Parallel to Grain F_{vo}	Compression Perpendicular to Grain F_{cpo}	
Douglas Fir-Larch	$\geq 1,000$	0.50	0.180	0.625	WCLIB, WWPA
	2,000	0.51	0.180	0.670	WCLIB, WWPA
	2,100	0.52	0.180	0.690	
	2,200	0.53	0.180	0.715	
	2,300	0.54	0.185	0.735	
	2,400	0.55	0.185	0.760	
Hem-Fir	$\geq 1,000$	0.43	0.150	0.405	WCLIB, WWPA
	1,600	0.44	0.155	0.510	WCLIB, WWPA
	1,700	0.45	0.160	0.535	
	1,800	0.46	0.160	0.555	
	1,900	0.47	0.165	0.580	
	2,000	0.48	0.170	0.600	
	2,100	0.49	0.170	0.625	
	2,200	0.50	0.175	0.645	
	2,300	0.51	0.190	0.670	
	2,400	0.52	0.190	0.690	
Southern Pine	$\geq 1,000$	0.55	0.175	0.565	SPIB
	$\geq 1,800$	0.57	0.190	0.805	SPIB
	$\geq 1,200$	0.42	0.135	0.425	NLGA
Spruce-Pine-Fir	1,800–1,900	0.46	0.160	0.525	NLGA
	$\geq 2,000$	0.50	0.170	0.615	
	$\geq 1,000$	0.36	0.135	0.335	NELMA, NSLB, WCLIB, WWPA
	1,200–1,900	0.42	0.150	0.465	NELMA, NSLB
Spruce-Pine-Fir (S)	1,200–1,700	0.42	0.150	0.465	WWPA
	1,800–1,900	0.46	0.160	0.555	NELMA, NSLB, WWPA
	$\geq 2,000$	0.50	0.175	0.645	

8.4.1.2—Structural Glued Laminated Timber (Glulam)

8.4.1.2.1—General

Structural glued laminated timber shall be manufactured using wet-use adhesives and shall comply with the requirements of ANSI/AITC A190.1-2002. Glued laminated timber may be manufactured from any lumber species, provided that it meets the requirements of ANSI/AITC A190.1 and is treatable with wood preservatives in accordance with the requirements of Article 8.4.3.

The contract documents shall require that each piece of glued laminated timber be distinctively marked and provided with a Certificate of Conformance by an accredited inspection and testing agency, indicating that the requirements of ANSI/AITC A190.1 have been met and that straight or slightly cambered bending members have been stamped TOP on the top at both ends so that the natural camber, if any, shall be positioned opposite to the direction of applied loads.

C8.4.1.2.1

When wet-use adhesives are used, the bond between the laminations, which is stronger than the wood, will be maintained under all exposure conditions. Dry-use adhesives will deteriorate under wet conditions. For bridge applications, it is not possible to ensure that all areas of the components will remain dry. ANSI/AITC A190.1-2002 requires the use of wet-use adhesives for the manufacture of structural glued laminated timber.

Industrial appearance grade, as defined in AITC 110-2001, *Standard Appearance Grades for Structural Glued Laminated Timber*, shall be used, unless otherwise specified.

Structural glued laminated timber is available in four standard appearance grades: framing, industrial, architectural, and premium. Architectural and premium grades are typically planed or sanded, and exposed irregularities are filled with a wood filler that may crack and dislodge under exterior exposure conditions. Framing grade is surfaced hit-or-miss to produce a timber with the same net width as standard lumber for concealed applications where matching the width of framing lumber is important. Framing grade is not typically used for bridge applications. In addition to the four standard appearance grades, certain manufacturers will use special surfacing techniques to achieve a desired look, such as a rough sawn look. Individual manufacturers should be contacted for details.

8.4.1.2.2—Dimensions

Dimensions stated for glued laminated timber shall be taken as the actual net dimensions.

In design, structural calculations shall be based on the actual net dimensions. Net width of structural glued laminated timber shall be as specified in Table 8.4.1.2.2-1 or other dimensions as agreed upon by buyer and seller.

C8.4.1.2.2

Structural glued laminated timber can be manufactured to virtually any shape or size. The most efficient and economical design generally results when standard sizes are used. Acceptable manufacturing tolerances are given in ANSI/AITC A190.1-2002.

The use of standard sizes constitutes good practice and is recommended whenever possible. Nonstandard sizes should only be specified after consultation with the laminator.

Southern Pine timbers are typically manufactured from 1.375-in. thick laminations, while timbers made from Western Species and Hardwoods are commonly manufactured from 1.5-in. thick laminations. Curved members may be manufactured from thinner laminations depending on the radius of curvature. Radii of curvature of less than 27.0 ft, 6.0 in. normally require the use of thinner laminations.

Table 8.4.1.2.2-1—Net Dimensions of Glued Laminated Timber

Nominal Width of Laminations (in.)	Western Species Net Finished Dimension (in.)	Southern Pine Net Finished Dimension (in.)
3	2 1/8 or 2 1/2	2 1/8 or 2 1/2
4	3 1/8	3.0 or 3 1/8
6	5 1/8	5.0 or 5 1/8
8	6 3/4	6 3/4
10	8 3/4	8 1/2
12	10 3/4	10 1/2
14	12 1/4	12.0
16	14 1/4	14.0

The total glulam net depth shall be taken as the product of the thickness of the laminations and the number of laminations.

8.4.1.2.3—Reference Design Values

Grade combinations for structural glued laminated timber shall be as provided in AITC 117-2004, *Standard Specifications for Structural Glued Laminated Timber of Softwood Species*, or AITC 119-96, *Standard Specifications for Structural Glued Laminated Timber of Hardwood Species*.

Reference Design Values for structural glued laminated timber shall be as specified in Tables 8.4.1.2.3-1 and 8.4.1.2.3-2:

- Table 8.4.1.2.3-1 contains design values for timbers with layups optimized to resist bending loads applied perpendicular to the wide face of the laminations (bending about the x - x axis). Design values are also included, however, for axial loads and bending loads applied parallel to the wide faces of the laminations. The design values in Table 8.4.1.2.3-1 are applicable to timbers with four or more laminations.
- Table 8.4.1.2.3-2 contains design values for timbers with uniform-grade layups. These layups are intended primarily for timbers loaded axially or in bending due to loads applied parallel to the wide faces of the laminations (bending about the y - y axis). Design values are also included, however, for bending due to loads applied perpendicular to the wide faces of the laminations. The design values in Table 8.4.1.2.3-2 are applicable to timbers with two or more laminations.

In Table 8.4.1.2.3-1, the tabulated design values, F_{bx} , for bending about the x - x axis (F_{bx}), require the use of special tension laminations. If these special tension laminations are omitted, value shall be multiplied by 0.75 for members greater than or equal to 15 in. in depth or by 0.85 for members less than 15 in. in depth.

In Table 8.4.1.2.3-1, the design value for shear, F_{vx} , shall be decreased by multiplying by a factor of 0.72 for nonprismatic members, notched members, and for all members subject to impact or cyclic loading. The reduced design value shall be used for design of members at connections that transfer shear by mechanical fasteners. The reduced design value shall also be used for determination of design values for radial tension and torsion. Design values, F_{vy} , shall be used for timbers with laminations made from a single piece of lumber across the width or multiple pieces that have been edge bonded. For timber manufactured from multiple-piece laminations (across width) that are not edge-bonded, in addition to other reduction, design value shall be multiplied by 0.4 for members with five, seven, or nine laminations or by 0.5 for all other members. If combination 24F-V4 contain lumber with wane, then, in addition, the design value for shear parallel to grain, F_{vx} , shall be multiplied by 0.67 if wane is allowed on both sides. If wane is limited to one side, F_{vx} , shall be multiplied by 0.83.

C8.4.1.2.3

The combinations in Table 8.4.1.2.3-1 are applicable to members consisting of four or more laminations and are intended primarily for members stressed in bending due to loads applied perpendicular to the wide faces of the laminations. However, design values are tabulated for loading both perpendicular and parallel to the wide faces of the laminations. The combinations and design values applicable to members loaded primarily axially or parallel to the wide faces of the laminations, are specified in Table 8.4.1.2.3-2. Design values for members of two or three laminations, are specified in Table 8.4.1.2.3-2.

In Table 8.4.1.2.3-2, for members with two or three laminations, the shear design value for transverse loads parallel to the wide faces of the laminations, F_{vy} , shall be reduced by multiplying by a factor of 0.84 or 0.95, respectively. For members with five, seven, or nine laminations, in addition, F_{vy} , shall be multiplied by 0.4 for members manufactured from multiple-piece laminations (across width) that are not edge bonded. The shear design value, F_{vy} , shall be multiplied by 0.5 for all other members manufactured from multiple-piece laminations with unbonded edge joints.

In Table 8.4.1.2.3-2, the design value for shear, F_{vx} , shall be decreased by multiplying by a factor of 0.72 for nonprismatic members, notched members, and for all members subject to impact or cyclic loading. The reduced design value shall be used for design of members at connections that transfer shear by mechanical fasteners. The reduced design value shall also be used for determination of design values for radial tension and torsion.

In Table 8.4.1.2.3-2, the tabulated design values shall apply to timbers without special tension laminations. If special tension laminations are used, for members to 15 in. deep the design value for bending, F_{bx} , may be increased by multiplying by 1.18. For members greater than 15 in. deep and without special tension laminations, the bending design value, F_{bx} , shall be reduced by multiplying by a factor of 0.88.

Reference design values for combinations not given in Table 8.4.1.2.3-1 or Table 8.4.1.2.3-2 shall be obtained from AITC 117-2004.

Table 8.4.1.2.3-1—Reference Design Values, ksi, for Structural Glued Laminated Softwood Timber Combinations (Members stressed primarily in bending)

Combination Symbol	Species Outer/ Core	Bending About X-X Axis (Loaded Perpendicular to Wide Faces of Laminations)						Bending About Y-Y Axis (Loaded Parallel to Wide Faces of Laminations)				Axially Loaded			Fasteners	
		Extreme Fiber in Bending		Compression Perpendicular to Grain		Shear Parallel to Grain (Horizontal)	Modulus of Elasticity	Extreme Fiber in Bending	Compression Perpendicular to Grain	Shear Parallel to Grain (Horizontal)	Modulus of Elasticity	Tension Parallel to Grain	Compression Parallel to Grain	Modulus of Elasticity	Specific Gravity for Fastener Design	
		Tension Zone Stressed in Tension F_{bxo}^+	Compression Zone Stressed in Tension F_{bxo}^-	Tension Face	Compression Face										Top or Bottom Face	Side Face
				F_{cpo}		F_{vxo}	E_{xo} (10^3)	F_{byo}	F_{cpo}	F_{vyo}	E_{yo} (10^3)	F_{to}	F_{co}	$E_{o\ axial}$ (10^3)		
20F-1.5E		2	1.1	0.425		0.21	1.5	0.8	0.315	0.185	1.2	0.725	0.925	1.3	0.42	
20F-V3	DF/DF	2.000	1.450	0.650	0.560	0.265	1.6	1.45	0.56	0.23	1.5	0.975	1.550	1.6	0.5	0.5
20F-V7	DF/DF	2.000	2.000	0.650	0.650	0.265	1.6	1.45	0.56	0.23	1.6	1.000	1.600	1.6	0.5	0.5
20F-V9	HF/HF	2.000	2.000	0.500	0.500	0.215	1.5	1.35	0.38	0.19	1.4	0.975	1.400	1.5	0.43	0.43
20F-V12	AC/AC	2.000	1.400	0.560	0.560	0.265	1.5	1.25	0.47	0.23	1.4	0.900	1.500	1.4	0.46	0.46
20F-V13	AC/AC	2.000	2.000	0.560	0.560	0.265	1.5	1.25	0.47	0.23	1.4	0.925	1.550	1.5	0.46	0.46
20F-V2	SP/SP	2.000	1.550	0.740	0.650	0.300	1.5	1.45	0.65	0.26	1.4	0.975	1.350	1.5	0.55	0.55
20F-V3	SP/SP	2.000	1.450	0.650	0.650	0.300	1.5	1.75	0.65	0.26	1.4	1.050	1.400	1.5	0.55	0.55
20F-V5	SP/SP	2.000	2.000	0.740	0.740	0.300	1.6	1.45	0.65	0.26	1.4	1.050	1.500	1.5	0.55	0.55
24F-1.7E		2.4	1.45	0.5		0.21	1.7	1.05	0.315	0.185	1.2	0.775	1	1.4	0.42	
24F-V5	DF/HF	2.400	1.600	0.650	0.650	0.215	1.7	1.20	0.38	0.19	1.5	1.150	1.450	1.6	0.5	0.43
24F-V10	DF/HF	2.400	2.400	0.650	0.650	0.215	1.8	1.45	0.38	0.19	1.5	1.100	1.550	1.6	0.5	0.43
24F-V1	SP/SP	2.400	1.750	0.740	0.650	0.300	1.7	1.45	0.65	0.26	1.5	1.100	1.550	1.6	0.55	0.55
24F-V4	SP/SP	2.400	1.450	0.740	0.650	0.210	1.7	1.05	0.47	0.19	1.3	0.875	1.000	1.5	0.55	0.43
24F-V5	SP/SP	2.400	2.400	0.740	0.740	0.300	1.7	1.75	0.65	0.26	1.5	1.150	1.650	1.6	0.55	0.55
24F-1.8E		2.4	1.45	0.65		0.265	1.8	1.45	0.56	0.23	1.6	1.1	1.6	1.7	0.5	
24F-V4	DF/DF	2.400	1.850	0.650	0.650	0.265	1.8	1.45	0.56	0.23	1.6	1.100	1.650	1.7	0.5	0.5
24F-V8	DF/DF	2.400	2.400	0.650	0.650	0.265	1.8	1.45	0.56	0.23	1.6	1.100	1.650	1.7	0.5	0.5
24F-V3	SP/SP	2.400	1.950	0.740	0.740	0.300	1.8	1.75	0.65	0.26	1.6	1.150	1.650	1.7	0.55	0.55
26F-1.9E		2.6	1.95	0.65		0.265	1.9	1.6	0.56	0.23	1.6	1.15	1.6	1.7	0.5	
26F-V1	DF/DF	2.600	1.950	0.650	0.650	0.265	2.0	1.750	0.560	0.230	1.8	1.300	1.850	1.9	0.5	0.5
26F-V2	DF/DF	2.600	2.600	0.650	0.650	0.265	2.0	1.750	0.560	0.230	1.8	1.300	1.850	1.9	0.5	0.5
26F-V2	SP/SP	2.600	2.100	0.740	0.740	0.300	1.9	2.200	0.740	0.260	1.8	1.250	1.650	1.9	0.55	0.55
26F-V4	SP/SP	2.600	2.600	0.740	0.740	0.300	1.9	2.100	0.650	0.260	1.8	1.200	1.600	1.9	0.55	0.55

Table 8.4.1.2.3-2—Reference Design Values, ksi, for Structural Glued Laminated Softwood Timber (Members stressed primarily in axial tension and compression)

Identification Number	Species	Grade	All Loading		Axially Loaded			Bending about Y-Y Axis				Bending About X-X Axis	
			Modulus of Elasticity E_o (10^3)	Compression Perpendicular to Grain F_{cpo}	Tension Parallel to Grain	Compression Parallel to Grain		Loaded Parallel to Wide Faces of Laminations			Loaded Perpendicular to Wide Faces of Laminations		
					2 or More Laminations F_{to}	4 or More Laminations F_{cpo}	2 or 3 Laminations F_{cpo}	Bending			Shear Parallel to Grain F_{vyo}	Bending	Shear Parallel to Grain
								4 or More Laminations F_{byo}	3 Laminations F_{byo}	2 Laminations F_{byo}			
Visually Graded Western Species													
1	DF	L3	1.5	0.560	0.900	1.550	1.200	1.450	1.250	1.000	0.230	1.250	0.265
2	DF	L2	1.6	0.560	1.250	1.950	1.600	1.800	1.600	1.300	0.230	1.700	0.265
3	DF	L2D	1.9	0.650	1.450	2.300	1.850	2.100	1.850	1.550	0.230	2.000	0.265
5	DF	L1	2.0	0.650	1.600	2.400	2.100	2.400	2.100	1.800	0.230	2.200	0.265
14	HF	L3	1.3	0.375	0.800	1.100	0.975	1.200	1.050	0.850	0.190	1.100	0.215
15	HF	L2	1.4	0.375	1.050	1.350	1.300	1.500	1.350	1.100	0.190	1.450	0.215
16	HF	L1	1.6	0.375	1.200	1.500	1.450	1.750	1.550	1.300	0.190	1.600	0.215
17	HF	L1D	1.7	0.500	1.400	1.750	1.700	2.000	1.850	1.550	0.190	1.900	0.215
69	AC	L3	1.2	0.470	0.725	1.150	1.100	1.100	0.975	0.775	0.230	1.000	0.265
70	AC	L2	1.3	0.470	0.975	1.450	1.450	1.400	1.250	1.000	0.230	1.350	0.265
71	AC	L1D	1.6	0.560	1.250	1.900	1.900	1.850	1.650	1.400	0.230	1.700	0.265
Visually Graded Southern Pine													
47	SP	N2M14	1.4	0.650	1.200	1.900	1.150	1.750	1.550	1.300	0.260	1.400	0.300
48	SP	N2D14	1.7	0.740	1.400	2.200	1.350	2.000	1.800	1.500	0.260	1.600	0.300
49	SP	N1M16	1.7	0.650	1.350	2.100	1.450	1.950	1.750	1.500	0.260	1.800	0.300
50	SP	N1D14	1.9	0.740	1.550	2.300	1.700	2.300	2.100	1.750	0.260	2.100	0.300

8.4.1.3—Tension-Reinforced Glulams

8.4.1.3.1—General

Tension-reinforced glulams shall incorporate a continuous reinforcement material placed on the tension side of a flexural member to increase its flexural bending strength and stiffness. Reinforcement may be any material that is not a conventional lamstock whose mean longitudinal unit strength exceeds 20 ksi for tension and compression mean ultimate strength, and whose mean tension and compression modulus of elasticity exceeds 3,000 ksi, when placed into a glulam timber. Acceptable reinforcing materials include but are not restricted to: Fiber-Reinforced Polymer (FRP) plates and bars using E-glass fibers (GFRP) or carbon fibers (CFRP), and metallic plates and bars.

The reinforced ratio, ρ , shall be determined as the cross-sectional area of tension reinforcement divided by cross-sectional area of beam above the center of gravity of tension reinforcement, expressed in percent. Typical reinforcement ratios and modulus of elasticity values for various types of reinforcement given in Table 8.4.1.3.1-1 shall apply.

Table 8.4.1.3.1-1—Typical Reinforcement Ratios

	Reinforcement Material			
	E-Glass FRP	Aramid FRP	Carbon FRP	Steel Plate
MOE (ksi)	6,000	10,000	20,000	30,000
Min. ρ %	1	0.6	0.3	0.2
Typical ρ %	2	1.2	0.6	0.4
Max. ρ %	3	1.8	0.9	0.6

Tension-reinforced glued laminated timber shall be manufactured using wet-use adhesives in accordance with applicable provisions of ANSI/AITC 190.1, and shall comply with the requirements listed in Article 8.4.1.2, except as described in detail in ASTM D7199. The additional requirements cited in ASTM D7199 to be investigated shall include bond strength and durability requirements for the tension reinforcement, preservative treatment, volume factor, and fatigue considerations.

8.4.1.3.2—Dimensions

Dimensions stated for tension-reinforced glued laminated timber shall be taken as the actual net dimensions.

In design, structural calculations shall be based on the actual net dimensions. Net width of tension-reinforced structural glued laminated timber shall be as specified in Table 8.4.1.2.2-1 or other dimensions as agreed upon by buyer and seller. The total reinforced glulam net depth shall be the sum of the thicknesses of all laminations including the thickness of the tension reinforcement lamination(s). The gross section properties shall be calculated using the net depth and the net width.

C8.4.1.3.1

The determination of reinforcement ratio, ρ , is analogous to that used for reinforced concrete.

The scope of ASTM D7199 pertains to the analysis of FRP-glulams in bending. The addition of FRP reinforcement in the tension region of the glulam does not require new test or analytical methods to determine the secondary design properties (shear, compression perpendicular to grain, tension parallel to grain, compression parallel to grain, etc.). These properties are determined for glulam layups following ASTM D3737.

Tension-reinforced glulam beams subject to axial compression loads are outside the scope of this Specification. This Specification does not cover unbonded reinforcement (i.e. material not continuously bonded to the beam), prestressed reinforcement (i.e. material pretensioned before being bonded or anchored to the beam), nor shear reinforcement (i.e. material intended to increase the shear strength of the beam).

ASTM D7199 also provides a mechanics-based approach for predicting the mechanical properties of tension-reinforced glulams, and may be used by engineers who have applications with unique reinforcement requirements. ASTM D7199 addresses methods to obtain bending properties parallel to grain about the x - x axis ($MOR_{5\%}$ and MOE) for horizontally-laminated reinforced glulam beams. Secondary properties such as bending about the y - y axis ($F_{b,y-y}$), shear parallel to grain (F_v), tension parallel to grain (F_t), compression parallel to grain (F_c), and compression perpendicular to grain ($F_{c\perp}$) are determined following methods described in ASTM D3737 or testing according to other applicable methods such as ASTM D198 or ASTM D143.

8.4.1.3.3—Fatigue

Except as noted herein, tension reinforcement shall extend the full length of the beam or girder and be confined by the supports.

For E-glass FRP reinforcement produced using the pultrusion process, beams which satisfy the requirements for design for static loads specified herein may be considered to have adequate fatigue design capacity. For reinforcements other than pultruded E-glass reinforcements, coupon level fatigue testing of the reinforcing material per ASTM D3479 or a similar procedure shall be required to develop the strength-load cycle relationship for the reinforcing material. A minimum of three representative FRP samples shall be tested to establish the strength-load cycle relationship. This strength-load cycle relationship shall be the basis for checking fatigue capacity of the FRP under specific end-use environment.

Full-scale fatigue testing shall be required where partial-length reinforcement is used to evaluate the effectiveness of reinforcement end-confinement detail. The reinforcement termination for partial-length FRP reinforcement shall be confined over the length at least equal to the width of the reinforcing material. Unconfined, partial-length reinforcement shall not be permitted in bridge applications where fatigue loading exists.

Full-scale fatigue testing shall be required on FRP-glulam beams where the allowable stress is more than 75 percent greater than conventional glulam ($F_b > 4000$ psi).

Where fatigue is a design consideration, the reinforcement used shall not increase the $MOR_{5\%}$ of the beam by more than 75 percent relative to the strength of the unreinforced beam.

8.4.1.3.4—Reference Design Values for Tension-Reinforced Glulams

Reference design values for tension-reinforced glulams shall be taken as specified in Table 8.4.1.3.4-1 for beams with no bumper-lams. For the beam lay-ups given in Table 8.4.1.3.4-1, the volume factor shall be taken equal to one. The values are for dry use, with adjustment factors given in Article 8.4.4.3 and shall be used in the same manner as conventional glulam design values except as specified in Article 8.4.1.3. These design values shall be used with the overall gross section properties of the beam, including the reinforcement.

C8.4.1.3.3

The research that was performed utilized confinement achieved by end-bearing support. Confinement proposed by alternative methods may require full-scale testing.

Under the specified conditions, testing has shown that the fatigue resistance of tension-reinforced glulam beams is similar to that of conventional glulam beams. These tests have included both fatigue and hygrothermal cyclic tests (Davids et al., 2005 and 2008).

For pultruded E-glass FRP reinforcement, full-scale tension-reinforced glulam beam flexural fatigue tests, where the reinforcement extends the full-length of the beam, have shown that the reinforced beams properly designed for static loads will have fatigue design capacity in excess of two million constant-amplitude sinusoidal cycles. Each of these cycles applied an extreme fiber stress range starting from the dead load bending stress to a bending stress equivalent to the full allowable design stress. Under these conditions, no degradation in bending strength or stiffness has been observed.

Full-scale fatigue testing has been performed on FRP-reinforced glulam beams, considering both full-length and partial-length reinforced glulams. These tests were conducted for tension-reinforced beams where the allowable design stresses were up to 75 percent greater than the conventional unreinforced glulam. This testing has shown that premature failure due to fatigue in FRP-glulams is not a concern if (1) the FRP reinforcement has been fatigue-tested at the coupon level and (2) the FRP tension reinforcement runs for the full length of the glulam over the supports. For partial-length reinforcement (where the FRP is terminated before the supports) and for FRP-glulams where the allowable stress is more than 75 percent greater than conventional glulam ($F_b > 4000$ psi), full-scale fatigue testing is required. Guidance on performing such tests can be found in Davids et al. (2005 and 2008). Fatigue tests where $MOR_{5\%}$ has been increased by more than 75 percent, flexural compression and shear failures have been observed in addition to flexural tension failures.

FRP coupon fatigue design data should be available from reinforced beam manufacturers or FRP suppliers. The vast majority of applications will not require full-scale fatigue testing of beams.

C8.4.1.3.4

Axial compression is outside the scope of this Specification. For tension-reinforced glulam subjected to axial compression, ASTM D3737 provides a method to account for the Neutral Axis (NA) change in unbalanced layups. FRP stiffness and shift in the neutral axis shall be accounted for when developing axial compression design values. Bending properties about the y - y axis may be conservatively taken as those of the wood-portion of the beam, neglecting the reinforcement.

Analysis has shown that with the level of FRP extreme fiber tension reinforcement typically envisioned (up to three percent GFRP or one percent CFRP), the maximum shear stress at the reinforced beam neutral axis is very similar to that of an unreinforced rectangular section. In addition, under the same conditions, the shear stress at the FRP-wood interface is always significantly smaller than the shear stress at the reinforced beam neutral axis.

Table 8.4.1.3.4-1—Reference Design Values for Tension-Reinforced Structural Glued Laminated Douglas Fir Combinations (ksi)¹

Combination Symbol	Species (Outer/Core)	Bending about x - x Axis					
		Extreme Fiber in Bending		Compression Perpendicular to Grain		Shear	Modulus of Elasticity $E_{xo} \times 10^3$
		Tension Zone Stressed in Tension F_{bxo+}	Compression Zone Stressed in Tension F_{bxo-}	Tension Face F_{cpo}	Compression Face F_{cpo}		
30F-1.9E							
30F-V1R	DF/DF	3.000	1.900	0.56	0.56	0.265	1.9
30F-2.0E							
30F-V4R	DF/DF	3.000	1.900	0.56	0.56	0.265	2.0
30F-2.1E							
30F-V7R	DF/DF	3.000	2.100	0.56	0.56	0.265	2.1
32F-2.1E							
32F-V1R	DF/DF	3.200	2.100	0.56	0.56	0.265	2.2
34F-2.2E							
34F-V1R	DF/DF	3.400	2.100	0.56	0.56	0.265	2.2

¹ Species other than Douglas Fir may be used if evaluated in accordance with ASTM D7199.

8.4.1.3.5—Volume Effect

Volume factors for the tension-reinforced glulams listed in Table 8.4.1.3.4-1 shall be taken equal to one except where the unreinforced compression zone is stressed in tension. In this latter case, the volume factor used in conventional glulams shall apply for the determination of this value.

C8.4.1.3.5

The addition of tension reinforcement diminishes the volume effect in glulams, and with enough reinforcement in tension, the volume effect disappears (Lindyberg, 2000). The tension reinforcement that is necessary to eliminate the volume effect varies with the wood species and grade, as well as the type of reinforcement used (e.g. E-glass, carbon, or Aramid FRP). For example, western species glulam reinforced with E-glass FRP in tension, approximately 1.5–3 percent FRP by volume will eliminate the volume effect (Lindyberg, 2000). For the particular glulams listed in Table 8.4.1.3.4-1, the E-glass tension reinforcement ratio is over three percent, and the corresponding volume factor is equal to one. If the tension reinforcement ratio is reduced the actual volume factor is a function of the reinforcement ratio and the reinforcement longitudinal stiffness. A numerical model that predicts the volume factor for reinforced glulams for any layup and type of reinforcement is available (Lindyberg, 2000).

8.4.1.3.6—Preservative Treatment

Designers shall specify that the effect of preservative treatment on the properties of the FRP reinforcement and on the strength and durability of the FRP-wood bond shall be evaluated as described in ASTM D7199. Preservative treatment shall be applied after bonding of the reinforcement. GFRP reinforced beams shall not be post-treated with CCA preservatives.

8.4.1.4—Piles

Wood piles shall comply with the requirements of AASHTO M 168.

Reference design values for round wood piles shall be as specified in Table 8.4.1.4-1.

Table 8.4.1.4-1—Reference Design Values for Piles, ksi

Species	F_{co}	F_{bo}	F_{cpo}	F_{vo}	E_o
Pacific Coast Douglas-Fir ¹	1.25	2.45	0.23	0.115	1500
Red Oak ²	1.10	2.45	0.35	0.135	1250
Red Pine ³	0.90	1.90	1.55	0.085	1280
Southern Pine ⁴	1.20	2.40	0.25	0.11	1500

¹ For connection design, use Douglas Fir-Larch reference design values.

² Red Oak reference strengths apply to Northern and Southern Red Oak.

³ Red Pine reference strengths apply to Red Pine grown in the U.S. For connection design, use Northern Pine reference design values.

⁴ Southern Pine reference strengths apply to Loblolly, Longleaf, Shortleaf, and Slash Pine.

C8.4.1.3.6

CCA preservative has been shown to cause severe cracking in the E-glass reinforcement.

C8.4.1.4

The reference design values for wood piles are based on wet-use conditions.

8.4.2—Metal Fasteners and Hardware**8.4.2.1—General**

Structural metal, including shapes, plates, bars, and welded assemblies, shall comply with the applicable material requirements of Section 6.

8.4.2.2—Minimum Requirements*8.4.2.2.1—Fasteners*

Bolts and lag screws shall comply with the dimensional and material quality requirements of ANSI/ASME B18.2.1, *Square and Hex Bolts and Screws—Inch Series*. Strengths for low-carbon steel bolts, Grade 1 through Grade 8, shall be as specified in Society of Automotive Engineers Specification SAE-429, *Mechanical and Material Requirements for Externally Threaded Fasteners*. Bolt and lag screw grades not given in SAE-429 shall have a minimum tensile yield strength of 33.0 ksi.

8.4.2.2.2—Prestressing Bars

Prestressing bars shall comply with the requirements of AASHTO M 275M/M 275 (ASTM A722/A722M) and the applicable provisions of Section 5.

8.4.2.2.3—Split Ring Connectors

Split ring connectors shall be manufactured from hot-rolled carbon steel complying with the requirements of Society of Automotive Engineers Specification SAE-1010. Each circular ring shall be cut through in one place in its circumference to form a tongue and slot.

8.4.2.2.4—Shear Plate Connectors

Shear plate connectors shall be manufactured from pressed steel, light gage steel, or malleable iron. Pressed steel connectors shall be manufactured from hot-rolled carbon steel meeting Society of Automotive Engineers Specification SAE-1010. Malleable iron connectors shall be manufactured in accordance with ASTM A47, Grade 32510.

Each shear plate shall be a circle with a flange around the edge, extending at right angles to the plate face from one face only.

8.4.2.2.5—Nails and Spikes

Nails and spikes shall be manufactured from common steel wire or high-carbon steel wire that is heat-treated and tempered. When used in withdrawal-type connections, the shank of the nail or spike shall be annularly or helically threaded.

8.4.2.2.6—Drift Pins and Bolts

Drift pins and drift bolts shall have a minimum flexural yield strength of 30.0 ksi.

8.4.2.2.7—Spike Grids

Spike grids shall conform to the requirements of ASTM A47, Grade 32510, for malleable iron casting.

8.4.2.2.8—Toothed Metal Plate Connectors

Metal plate connectors shall be manufactured from galvanized sheet steel that complies with the requirements of ASTM A653, Grade A, or better, with the following minimum mechanical properties:

Yield Point	33.0 ksi
Ultimate Strength	45.0 ksi
Elongation in 2.0 in.	20 percent

8.4.2.3—Corrosion Protection

8.4.2.3.1—Metallic Coating

Except as permitted by this Section, all steel hardware for wood components shall be galvanized in accordance with AASHTO M 232M/M 232 (ASTM A153/A153M) or cadmium plated in accordance with AASHTO M 299 (ASTM B696).

Except as otherwise permitted, all steel components, timber connectors, and castings other than malleable iron shall be galvanized in accordance with AASHTO M 111M/M 111 (ASTM A123/A123M).

8.4.2.3.2—Alternative Coating

Alternative corrosion protection coatings may be used when the demonstrated performance of the coating is sufficient to provide adequate protection for the intended exposure condition during the design life of the bridge. When epoxy coatings are used, minimum coating requirements shall comply with AASHTO M 284M/M 284.

Heat-treated alloy components and fastenings shall be protected by an approved alternative protective treatment that does not adversely affect the mechanical properties of the material.

8.4.3—Preservative Treatment

8.4.3.1—Requirement for Treatment

All wood used for permanent applications shall be pressure impregnated with wood preservative in accordance with the requirements of AASHTO M 133.

Insofar as is practicable, all wood components should be designed and detailed to be cut, drilled, and otherwise fabricated prior to pressure treatment with wood preservatives. When cutting, boring, or other fabrication is necessary after preservative treatment, exposed, untreated wood shall be specified to be treated in accordance with the requirements of AASHTO M 133.

8.4.3.2—Treatment Chemicals

Unless otherwise approved, all structural components that are not subject to direct pedestrian contact shall be treated with oil-borne preservatives. Pedestrian railings and nonstructural components that are subject to direct pedestrian contact shall be treated with water-borne preservatives or oil-borne preservatives in light petroleum solvent.

C8.4.2.3.1

Galvanized nuts should be retapped to allow for the increased diameter of the bolt due to galvanizing.

Protection for the high-strength bars used in stress-laminated decks should be clearly specified. Standard hot-dip galvanizing can adversely affect the properties of high-strength post-tensioning materials. A lower temperature galvanizing is possible with some high-strength bars. The manufacturer of the bars should be consulted on this issue.

C8.4.3.2

The oil-borne preservative treatments have proven to provide adequate protection against wood attacking organisms. In addition, the oil provides a water repellent coating that reduces surface effects caused by cyclic moisture conditions. Water-borne preservative treatments do not provide the water repellency of the oil-borne treatment, and components frequently split and check, leading to poor field performance and reduced service life.

Direct pedestrian contact is considered to be contact that can be made while the pedestrian is situated anywhere in the access route provided for pedestrian traffic.

Treating of glued laminated timbers with water-borne preservatives after gluing is not recommended. Use of water-borne treatments for glued laminated timber after gluing may result in excessive warping, checking, or splitting of the components due to post-treatment re-drying.

8.4.3.3—Inspection and Marking

Preservative treated wood shall be tested and inspected in accordance with the requirements of AASHTO M 133. Where size permits, each piece of treated wood that meets treatment requirements shall be legibly stamped, branded, or tagged to indicate the name of the treater and the specification symbol or specification requirements to which the treatment conforms.

When requested, a certification indicating test results and the identification of the inspection agency shall be provided.

8.4.3.4—Fire Retardant Treatment

Fire retardant treatments shall not be applied unless it is demonstrated that they are compatible with the preservative treatment used, and the usable resistance and stiffness are reduced as recommended by the product manufacturer and applicator.

C8.4.3.4

Use of fire retardant treatments is not recommended because the large sizes of timber components typically used in bridge construction have inherent fire resistance characteristics. The pressure impregnation of wood products with fire retardant chemicals is known to cause certain resistance and stiffness losses in the wood. These resistance and stiffness losses vary with specific resistance characteristic, i.e., bending resistance, tension parallel to grain resistance, etc., treatment process, wood species and type of wood product, i.e., solid sawn, glued laminated, or other.

8.4.4—Adjustment Factors for Reference Design Values

8.4.4.1—General

Adjusted design values shall be obtained by adjusting reference design values by applicable adjustment factors in accordance with the following equations:

$$F_b = F_{bo} C_{KF} C_M (C_F \text{ or } C_v) C_{fu} C_i C_d C_\lambda \quad (8.4.4.1-1)$$

$$F_v = F_{vo} C_{KF} C_M C_i C_\lambda \quad (8.4.4.1-2)$$

$$F_t = F_{to} C_{KF} C_M C_F C_i C_\lambda \quad (8.4.4.1-3)$$

$$F_c = F_{co} C_{KF} C_M C_F C_i C_\lambda \quad (8.4.4.1-4)$$

$$F_{cp} = F_{cpo} C_{KF} C_M C_i C_\lambda \quad (8.4.4.1-5)$$

$$E = E_o C_M C_i \quad (8.4.4.1-6)$$

where:

F = applicable adjusted design values F_b , F_v , F_t , F_c , or F_{cp} (ksi)

F_o = reference design values F_{bo} , F_{vo} , F_{to} , F_{co} , or F_{cpo} specified in Article 8.4 (ksi)

- E = adjusted modulus of elasticity (ksi)
- E_o = reference modulus of elasticity specified in Article 8.4. (ksi)
- C_{KF} = format conversion factor specified in Article 8.4.4.2
- C_M = wet service factor specified in Article 8.4.4.3
- C_F = size factor for visually-graded dimension lumber and sawn timbers specified in Article 8.4.4.4
- C_V = volume factor for structural glued laminated timber specified in Article 8.4.4.5
- C_{fu} = flat-use factor specified in Article 8.4.4.6
- C_i = incising factor specified in Article 8.4.4.7
- C_d = deck factor specified in Article 8.4.4.8
- C_λ = time effect factor specified in Article 8.4.4.9

8.4.4.2—Format Conversion Factor, C_{KF}

The reference design values in Tables 8.4.1.1.4-1, 8.4.1.1.4-2, 8.4.1.1.4-3, 8.4.1.2.3-1, 8.4.1.2.3-2, 8.4.1.3.4-1, and 8.4.1.4-1 and reference design values specified in the $NDS^{\text{®}}$ shall be multiplied by a format conversion factor, C_{KF} , for use with load and resistance factor design (LRFD). $C_{KF} = 2.5/\phi$, except for compression perpendicular to grain which shall be obtained by multiplying the allowable stress by a format conversion factor of $C_{KF} = 2.1/\phi$.

C8.4.4.2

The conversion factors were derived so that LRFD design will result in same size member as the allowable stress design (ASD) specified in $NDS^{\text{®}}$. For example, a rectangular component in flexure has to satisfy:

$$1.25 M_{DL} + 1.75 M_{LL} \leq \phi S F_{bo} C_{KF} C_M (C_F \text{ or } C_V) C_{fu} C_i C_d C_\lambda C_L \quad (\text{C8.4.4.2-1})$$

or:

$$(1.25 M_{DL} + 1.75 M_{LL}) / (\phi C_{KF} C_\lambda) \leq S F_{bo} C_M (C_F \text{ or } C_V) C_{fu} C_i C_d C_L \quad (\text{C8.4.4.2-2})$$

where:

M_{DL} = moment due to dead load

M_{LL} = moment due to live load

On the other hand, the allowable stress design (ASD) has to satisfy:

$$M_{DL} + M_{LL} \leq S F_{bo} C_M (C_F \text{ or } C_V) C_{fu} C_i C_d C_D C_L \text{ or } (M_{DL} + M_{LL}) / (C_D) \leq S F_{bo} C_M (C_F \text{ or } C_V) C_{fu} C_i C_d C_L \quad (\text{C8.4.4.2-3})$$

Therefore:

$$(1.25 M_{DL} + 1.75 M_{LL}) / (\phi C_{KF} C_\lambda) = (M_{DL} + M_{LL}) / (C_D) \quad (\text{C8.4.4.2-4})$$

$$C_{KF} = [(1.25 M_{DL} + 1.75 M_{LL})(C_D)] / [(M_{DL} + M_{LL})(\phi C_\lambda)] \quad (\text{C8.4.4.2-5})$$

The format conversion factor is calculated assuming the ratio of M_{DL} and M_{LL} is 1:10, $\phi = 0.85$, $C_\lambda = 0.8$, and $C_D = 1.15$.

8.4.4.3—Wet Service Factor, C_M

The reference design values specified in Tables 8.4.1.1.4-1, 8.4.1.1.4-2, 8.4.1.1.4-3, 8.4.1.2.3-1, 8.4.1.2.3-2, 8.4.1.3.4-1, and 8.4.1.4-1 are for dry use conditions and shall be adjusted for moisture content using the wet service factor, C_M , specified below:

- For sawn lumber with an in-service moisture content of 19 percent or less, C_M shall be taken as 1.0.
- For glued laminated and tension-reinforced glued laminated (reinforced and unreinforced) timber with an in-service moisture content of 16 percent or less, C_M shall be taken as 1.0.
- Otherwise, C_M shall be taken as specified in Tables 8.4.4.3-1 for sawn lumber and Table 8.4.4.3-2 for reinforced and unreinforced glued laminated timber, respectively.

Reference design values for Southern Pine and Mixed Southern Pine sawn timbers 5 in. \times 5 in. and larger shall be taken to apply to wet or dry use.

The wet service factors for reinforced and unreinforced glued laminated timber shall be the same.

C8.4.4.3

An analysis of in-service moisture content should be based on regional, geographic, and climatological conditions. In the absence of such analysis, wet-use conditions should be assumed.

Reduction for wet-use is not required for Southern Pine and Mixed Southern Pine sawn timbers 5 in. \times 5 in. and larger.

Table 8.4.4.3-1—Wet Service Factor for Sawn Lumber, C_M

Nominal Thickness	$F_{bo}C_F \leq 1.15$ ksi	$F_{bo}C_F > 1.15$ ksi	F_{to}	$F_{co}C_F \leq 0.75$ ksi	$F_{co}C_F > 0.75$ ksi	F_{vo}	F_{cpo}	E_o
≤ 4 in.	1.00	0.85	1.00	1.00	0.80	0.97	0.67	0.90
> 4.0 in.	1.00	1.00	1.00	0.91	0.91	1.00	0.67	1.00

Table 8.4.4.3-2—Wet Service Factor for Glued Laminated Timber and Tension-Reinforced Glued Laminated Timber, C_M

F_{bo}	F_{vo}	F_{to}	F_{co}	F_{cpo}	E_o
0.80	0.875	0.80	0.73	0.53	0.833

8.4.4.4—Size Factor, C_F , for Sawn Lumber

The size factor, C_F , shall be 1.0 unless specified otherwise herein.

For visually-graded dimension lumber of all species except Southern Pine and Mixed Southern Pine, C_F shall be as specified in Table 8.4.4.4-1.

Reference design values for Southern Pine and Mixed Southern Pine dimension lumber have been size-adjusted; no further adjustment for size shall be applied.

For Southern Pine and Mixed Southern Pine dimension lumber wider than 12.0 in., the tabulated bending, compression, and tension parallel to grain design values, for the 12.0 in. depth, shall be multiplied by the size factor, $C_F = 0.9$.

C8.4.4.4

C_F does not apply to mechanically-graded lumber (MSR, MEL) or to structural glued laminated timber.

Tabulated design values for visually-graded lumber of Southern Pine and Mixed Southern Pine species groups have already been adjusted for size. Further adjustment by the size factor is not permitted.

Table 8.4.4.4-1—Size Effect Factor, C_F , for Sawn Dimension Lumber

Grade	Width (in.)	F_{bo}		F_{to}	F_{co}	All Other Properties	
		Thickness					
		2.0 in. and 3.0 in.	4.0 in.	All	All		All
		Structural Light Framing: 2.0 in. × 2.0 in. through 4.0 in. × 4.0 in. Structural Joists and Planks: 2.0 in. × 5.0 in. through 4.0 in. × 16.0 in.					
	≤4	1.5	1.54	1.5	1.15		
Sel. Str.	5	1.4	1.4	1.4	1.1		
No. 1	6	1.3	1.3	1.3	1.1		
No. 2	8	1.2	1.3	1.2	1.05	1.00	
	10	1.1	1.2	1.1	1.0		
	12	1.0	1.1	1.0	1.0		
	≥14	0.9	1.0	0.9	0.9		

For sawn beams and stringers with loads applied to the narrow face and posts and timbers with loads applied to either face, F_{bo} shall be adjusted by C_F determined as:

- If $d \leq 12.0$ in., then

$$C_F = 1.0 \quad (8.4.4.4-1)$$

- If $d > 12.0$ in., then

$$C_F = \left(\frac{12}{d} \right)^{\frac{1}{9}} \quad (8.4.4.4-2)$$

where:

d = net width as shown in Figure 8.3-1

For beams and stringers with loads applied to the wide face, F_{bo} shall be adjusted by C_F as specified in Table 8.4.4.4-2.

Table 8.4.4.4-2—Size Factor, C_F , for Beams and Stringers with Loads Applied to the Wide Face

Grade	F_{bo}	E_o	Other Properties
SS	0.86	1.00	1.00
No. 1	0.74	0.90	1.00
No. 2	1.00	1.00	1.00

8.4.4.5—Volume Factor, C_V , (Glulam)

For horizontally laminated glulam, with loads applied perpendicular to the wide face of the laminations, F_{bo} shall be reduced by C_V , given below, when the depth, width, or length of a glued laminated timber exceeds 12.0 in., 5.125 in., or 21.0 ft, respectively:

$$C_v = \left[\left(\frac{12.0}{d} \right) \left(\frac{5.125}{b} \right) \left(\frac{21}{L} \right) \right]^a \leq 1.0 \quad (8.4.4.5-1)$$

where:

- d = depth of the component (in.)
- b = width of the component (in.) For layups with multiple piece laminations (across the width) b = width of widest piece. Therefore: $b \leq 10.75$ in.
- L = length of the component measured between points of contraflexure (ft)
- a = 0.05 for Southern Pine and 0.10 for all other species.

The volume factor, C_v , shall not be applied simultaneously with the beam stability factor, C_L , therefore, the lesser of these factors shall apply.

The conventional glulam volume factor shall not be applied to tension-reinforced glulams except when unreinforced compression zone is stressed in tension (see Article C8.4.1.3.5). For tension-reinforced glulam beams where unreinforced compression zone is stressed in tension the volume factor, C_v , the same as for conventional glulam, shall be used.

8.4.4.6—Flat-Use Factor, C_{fu}

When dimension lumber graded as *Structural Light Framing* or *Structural Joists and Planks* is used flatwise (load applied to the wide face), the bending reference design value shall be multiplied by the flat use factor specified in Table 8.4.4.6-1.

The flat-use factor shall not apply to dimension lumber graded as *Decking*.

Table 8.4.4.6-1—Flat-Use Factor, C_{fu} , for Dimension Lumber

Width (in.)	Thickness (in.)	
	2 and 3	4
2 and 3	1.0	—
4	1.1	1.0
5	1.1	1.05
6	1.15	1.05
8	1.15	1.05
≥10	1.2	1.1

Reference design values for flexure of vertically laminated glulam (loads applied parallel to wide faces of laminations) shall be multiplied by the flat use factors specified in Table 8.4.4.6-2 when the member dimension parallel to wide faces of laminations is less than 12.0 in.

C8.4.4.6

Design values for flexure of dimension lumber adjusted by the size factor, C_F , are based on edgewise use (load applied to the narrow face). When dimension lumber is used flatwise (load applied to the wide face), the bending reference design value should also be multiplied by the flat use factor specified in Table 8.4.4.6-1.

Design values for dimension lumber graded as *Decking* are based on flatwise use. Further adjustment by the flat-use factor is not permitted.

Table 8.4.4.6-2—Flat-Use Factor, C_{fu} , for Glulam

Member dimension parallel to wide faces of laminations (in.)	C_{fu}
10 3/4 or 10 1/2	1.01
8 3/4 or 8 1/2	1.04
6 3/4	1.07
5 1/8 or 5	1.10
3 1/8 or 3	1.16
2 1/2 or 2 1/8	1.19

8.4.4.7—Incising Factor, C_i

Reference design values for dimension lumber shall be multiplied by the incising factor specified in Table 8.4.4.7-1 when members are incised parallel to grain a maximum depth of 0.4 in., a maximum length of 3/8 in., and a density of incisions up to 1100/ft². Incising factors shall be determined by test or by calculation using reduced section properties for incising patterns exceeding these limits.

Table 8.4.4.7-1—Incising Factor for Dimension Lumber

Design Value	C_i
E_o	0.95
F_{bo} , F_{to} , F_{co} , F_{vo}	0.80
F_{cpo}	1.00

8.4.4.8—Deck Factor, C_d

Unless specified otherwise in this Article, the deck factor, C_d , shall be equal to 1.0.

For stressed wood, nail-laminated, and spike-laminated decks constructed of solid sawn lumber 2.0 in. to 4.0 in. thick, F_{bo} may be adjusted by C_d as specified in Table 8.4.4.8-1.

Table 8.4.4.8-1—Deck Factor for Stressed Wood and Laminated Decks

Deck Type	Lumber Grade	
Stressed Wood	Select Structural	1.30
	No. 1 or No. 2	1.50
Spike-Laminated or Nail-Laminated	All	1.15

C8.4.4.8

Mechanically laminated decks made of stressed wood, spike laminated, or nail-laminated solid sawn lumber exhibit an increased resistance in bending. The resistance of mechanically laminated solid sawn lumber decks is calculated by multiplying F_{bo} in Table 8.4.1.1.4-1 by the deck factor.

Deck factor is used instead of the repetitive member factor that is used in $NDS^{\text{®}}$.

For planks 4 × 6 in., 4 × 8 in., 4 × 10 in. and 4 × 12 in., used in plank decks with the load applied to the wide face of planks, F_{bo} may be adjusted by C_d as specified in Table 8.4.4.8-2.

Table 8.4.4.8-2—Deck Factor for Plank Decks

Size (in.)	C_d
4 × 6	1.10
4 × 8	1.15
4 × 10	1.25
4 × 12	1.50

The deck factors for planks in plank decks shall not be applied cumulatively with the flat use factor, C_{fu} , specified in Article 8.4.4.6.

8.4.4.9—Time Effect Factor, C_λ

The time effect factor, C_λ shall be chosen to correspond to the appropriate strength limit state as specified in Table 8.4.4.9-1.

Table 8.4.4.9-1—Time Effect Factor

Limit State	C_λ
Strength I	0.8
Strength II	1.0
Strength III	1.0
Strength IV	0.6
Extreme Event I	1.0

8.5—LIMIT STATES

8.5.1—Service Limit State

The provisions of Article 2.5.2.6.2 should be considered.

8.5.2—Strength Limit State

8.5.2.1—General

Factored resistance shall be the product of nominal resistance determined in accordance with Article 8.6, 8.7, 8.8, and 8.9 and the resistance factor as specified in Article 8.5.2.2.

The specified deck factors for planks in plank decks are based test results comparing the modulus of rupture (MOR) for plank specimens with load applied in narrow face and wide face (*Stankiewicz and Nowak, 1997*). These deck factors can be applied cumulatively with the size factor, C_F , specified in Article 8.4.4.4.

C8.4.4.9

NDS[®] and AITC 117-2004 reference design values (based on 10-yr loading) multiplied by the format conversion factors specified in Article 8.4.4.2, transform allowable stress values to strength level stress values based on 10-min. loading. It is assumed that a cumulative duration of bridge live load is two months and the corresponding time effect factor for Strength I is 0.8. A cumulative duration of live load in Strength II is shorter and the corresponding time effect factor for Strength II is 1.0. Resistance of wood subjected to long-duration loads is reduced. Load combination IV consists of permanent loads, including dead load and earth pressure.

8.5.2.2—Resistance Factors

Resistance factors, ϕ , shall be as given below:

Flexure	$\phi = 0.85$
Shear	$\phi = 0.75$
Compression Parallel to Grain	$\phi = 0.90$
Compression Perpendicular to Grain	$\phi = 0.90$
Tension Parallel to Grain	$\phi = 0.80$
Resistance During Pile Driving.....	$\phi = 1.15$
Connections	$\phi = 0.65$

8.5.2.3—Stability

The structure as a whole or its components shall be proportioned to resist sliding, overturning, uplift, and buckling.

8.5.3—Extreme Event Limit State

For extreme event limit state, the resistance factor shall be taken as 1.0.

8.6—COMPONENTS IN FLEXURE**8.6.1—General**

The factored resistance, M_r , shall be taken as:

$$M_r = \phi M_n \quad (8.6.1-1)$$

where:

M_n = nominal resistance specified herein (kip-in.)

ϕ = resistance factor specified in Article 8.5.2

8.6.2—Rectangular Section

The nominal resistance, M_n , of a rectangular component in flexure shall be determined from:

$$M_n = F_b S C_L \quad (8.6.2-1)$$

in which:

$$C_L = \frac{1+A}{1.9} - \sqrt{\frac{(1+A)^2}{3.61} - \frac{A}{0.95}} \quad (8.6.2-2)$$

$$A = \frac{F_{bE}}{F_b} \quad (8.6.2-3)$$

C8.5.2.2

In the case of timber pile foundations, the resistance factor may be raised to 1.0 when, in the judgment of the Engineer, a sufficient number of piles is used in a foundation element to consider it to be highly redundant. This is indicated to be a judgment issue because there are no generally accepted quantitative guidelines at this writing.

For timber piles, the resistance factor to be applied when determining the maximum allowable driving resistance accounts for the short duration of the load induced by the pile driving hammer.

C8.6.2

If lateral support is provided to prevent rotation at the points of bearing, but no other lateral support is provided throughout the bending component length, the unsupported length, L_u , is the distance between such points of intermediate lateral support.

The volume factor for the tension-reinforced glulams listed in Table 8.4.1.3.4-1 is equal to one; therefore, for these beams, C_L will always be less or equal to C_V , and C_L will control the modification factor for the allowable bending strength F_b .

$$F_{bE} = \frac{K_{bE} E}{R_B^2} \quad (8.6.2-4)$$

$$R_b = \sqrt{\frac{L_e d}{b^2}} \leq 50 \quad (8.6.2-5)$$

where:

K_{bE} = 0.76 for visually graded lumber

K_{bE} = 0.98 for MEL lumber

K_{bE} = 1.06 for MSR lumber

K_{bE} = 1.10 for glulam and tension-reinforced glulam

F_b = adjusted design value in flexure specified in Article 8.4.4 (ksi)

E = adjusted modulus of elasticity specified in Article 8.4.4 (ksi)

C_L = beam stability factor for both conventional glulam and tension-reinforced glulam

d = net depth specified in Article 8.4.1.1.2 (in.)

b = net width, as specified in Article 8.4.1.1.2 (in.)

L_e = effective unbraced length (in.)

S = section modulus (in.³)

Where the depth of a flexural component does not exceed its width, or where lateral movement of the compression zone is prevented by continuous support and where points of bearing have lateral support to prevent rotation, the stability factor, $C_L = 1.0$. For other conditions, the beam stability factor shall be determined in accordance with the provisions specified herein.

The beam stability factor shall not be applied simultaneous with the volume factor for structural glued laminated timber, therefore, the lesser of these factors shall apply.

The effective unbraced length, L_e , may be determined as:

- If $L_u/d < 7$, then $L_e = 2.06 L_u$
- If $7 \leq L_u/d \leq 14.3$, then $L_e = 1.63 L_u + 3d$
- If $L_u/d > 14.3$, then $L_e = 1.84 L_u$

where:

L_u = distance between point of lateral and rotational support (in.)

d = net depth specified in Article 8.4.1.1.2 (in.)

8.6.3—Circular Section

The nominal resistance, M_n , of a circular component in flexure shall be taken as:

$$M_n = F_b S \quad (8.6.3-1)$$

8.7—COMPONENTS UNDER SHEAR

Shear shall be investigated at a distance away from the face of support equal to the depth of the component. When calculating the maximum design shear, the live load shall be placed so as to produce the maximum shear at a distance from the support equal to the lesser of either three times the depth, d , of the component or one-quarter of the span L .

The factored shear resistance, V_r , of a component of rectangular cross-section shall be calculated from:

$$V_r = \phi V_n \quad (8.7-1)$$

in which:

$$V_n = \frac{F_v b d}{1.5} \quad (8.7-2)$$

where:

ϕ = resistance factor specified in Article 8.5.2

F_v = adjusted design value of wood in shear, specified in Article 8.4.1 (ksi)

8.8—COMPONENTS IN COMPRESSION

8.8.1—General

The factored resistance in compression, P_r , shall be taken as:

$$P_r = \phi P_n \quad (8.8.1-1)$$

where:

P_n = nominal resistance as specified in Article 8.8.2 and 8.8.3 (kips)

ϕ = resistance factor specified in Article 8.5.2

8.8.2—Compression Parallel to Grain

Where components are not adequately braced, the nominal stress shall be modified by the column stability factor, C_p . If the component is adequately braced, C_p shall be taken as 1.0.

The nominal resistance, P_n , of a component in the compression parallel to grain shall be taken as:

C8.7

The critical section is between one and three depths from the support.

The critical shear in flexural components is horizontal shear acting parallel to the grain of the component. The resistance of bending components in shear perpendicular to grain need not be investigated.

Note that Eq. 4.6.2.2.2a-1 requires a special distribution factor in the calculation of the live load force effect when investigating shear parallel to the grain.

C8.8.2

The coefficient of variation of the bending Modulus of Rupture (MOR) of tension-reinforced glulams has been shown through extensive testing to be less than or equal to that of conventional unreinforced glulams. Therefore, it is conservative to use $K_{cE} = 0.76$ for tension-reinforced glulams.

$$P_n = F_c A_g C_p \quad (8.8.2-1)$$

in which:

$$C_p = \frac{1+B}{2c} - \sqrt{\left(\frac{1+B}{2c}\right)^2 - \frac{B}{c}} \leq 1.0 \quad (8.8.2-2)$$

$$B = \frac{F_{cE}}{F_c} \leq 1.0 \quad (8.8.2-3)$$

$$F_{cE} = \frac{K_{cE} E d^2}{L_e^2} \quad (8.8.2-4)$$

where:

c = 0.8 for sawn lumber

c = 0.85 for round timber piles

c = 0.9 for glulam

K_{cE} = 0.52 for visually graded lumber

K_{cE} = 0.67 for MEL lumber

K_{cE} = 0.73 for MSR lumber

K_{cE} = 0.76 for glulam, tension-reinforced glulam, and round piles

F_c = adjusted design value in compression parallel to the grain specified in Article 8.4.4 (ksi)

L_e = effective length taken as KL (in.)

A_g = gross cross-sectional area of the component (in.²)

8.8.3—Compression Perpendicular to Grain

The nominal resistance, P_n , of a component in compression perpendicular to the grain shall be taken as:

$$P_n = F_{cp} A_b C_b \quad (8.8.3-1)$$

where:

F_{cp} = adjusted design value in compression perpendicular to grain, as specified in Article 8.4.4 (ksi)

A_b = bearing area (in.²)

C_b = bearing adjustment factor specified in Table 8.8.3-1

When the bearing area is in a location of high flexural stress or is closer than 3.0 in. from the end of the component, C_b shall be taken as 1.0. In all other cases, C_b shall be as specified in Table 8.8.3-1.

Table 8.8.3-1—Adjustment Factors for Bearing

Length of bearing measured along the grain, in.							
C_b	0.5	1.0	1.5	2.0	3.0	4.0	≥ 6.0
	1.75	1.38	1.25	1.19	1.13	1.10	1.00

8.9—COMPONENTS IN TENSION PARALLEL TO GRAIN

The factored resistance, P_r , of a component in tension shall be taken as:

$$P_r = \phi P_n \quad (8.9-1)$$

in which:

$$P_n = F_t A_n \quad (8.9-2)$$

where:

F_t = adjusted design value of wood in tension specified in Article 8.4.4 (ksi)

A_n = smallest net cross-sectional area of the component (in.²)

ϕ = resistance factor specified in Article 8.5.2

8.10—COMPONENTS IN COMBINED FLEXURE AND AXIAL LOADING

8.10.1—Components in Combined Flexure and Tension

Components subjected to flexure and tension shall satisfy:

$$\frac{P_u}{P_r} + \frac{M_u}{M_r^*} \leq 1.0 \quad (8.10.1-1)$$

and

$$\frac{M_u - \frac{d}{6} P_u}{M_r^{**}} \leq 1.0 \quad (8.10.1-2)$$

where:

P_u = factored tensile load (kips)

P_r = factored tensile resistance calculated as specified in Article 8.9 (kips)

M_u = factored flexural moment (kip-in.)

M_r^* = $F_b S$

M_r^{**} = factored flexural resistance adjusted by all applicable adjustment factors except C_V

C8.10.1

Satisfying Eq. 8.10.1-1 ensures that stress interaction on the tension face of the bending member does not cause beam rupture. M_r^* in this formula does not include modification by the beam stability factor, C_L .

Eq. 8.10.1-2 is applied to ensure that the bending/tension member does not fail due to lateral buckling of the compression face.

8.10.2—Components in Combined Flexure and Compression Parallel to Grain

Components subjected to flexure and compression parallel to grain shall satisfy:

$$\left(\frac{P_u}{P_r}\right)^2 + \frac{M_u}{M_r \left(1 - \frac{P_u}{F_{cE} A_g}\right)} \leq 1.0 \quad (8.10.2-1)$$

where:

P_u = factored compression load (kips)

P_r = factored compressive resistance calculated as specified in Article 8.8 (kips)

M_u = factored flexural moment (kip-in.)

M_r = factored flexural resistance calculated as specified in Article 8.6 (kip-in.)

F_{cE} = Euler buckling stress as defined in Eq. 8.8.2-4

A_g = gross cross-sectional area

8.11—BRACING REQUIREMENTS

8.11.1—General

Where bracing is required, it shall prevent both lateral and rotational deformation.

8.11.2—Sawn Wood Beams

Beams shall be transversely braced to prevent lateral displacement and rotation of the beams and to transmit lateral forces to the bearings. Transverse bracing shall be provided at the supports for all span lengths and at intermediate locations for spans longer than 20.0 ft. The spacing of intermediate bracing shall be based on lateral stability and load transfer requirements but shall not exceed 25.0 ft. The depth of transverse bracing shall not be less than three-fourths the depth of the stringers or girders.

Transverse bracing should consist of solid wood blocking or fabricated steel shapes. Wood blocking shall be bolted to stringers with steel angles or suspended in steel saddles that are nailed to the blocks and stringer sides. Blocking shall be positively connected to the beams.

Transverse bracing at supports may be placed within a distance from the center of bearing equal to the stringer or girder depth.

C8.11.1

In detailing of the diaphragms, the potential for shrinkage and expansion of the beam and the diaphragm should be considered. Rigidly connected steel angle framing may cause splitting of the beam and diaphragm as the wood attempts to swell and shrink under the effects of cyclic moisture.

C8.11.2

The effectiveness of the transverse bracing directly affects the long-term durability of the system. The bracing facilitates erection, improves load distribution, and reduces relative movements of the stringers and girders, thereby reducing deck deformations. Excessive deformation can lead to mechanical deterioration of the system.

Bracing should be accurately framed to provide full bearing against stringer sides. Wood cross-frames or blocking that are toe-nailed to stringers have been found to be ineffective and should not be used.

8.11.3—Glued Laminated Timber Girders

Transverse bracing should consist of fabricated steel shapes or solid wood diaphragms.

Girders shall be attached to supports with steel shoes or angles that are bolted through the girder and into or through the support.

8.11.4—Bracing of Trusses

Wood trusses shall be provided with a rigid system of lateral bracing in the plane of the loaded chord. Lateral bracing in the plane of the unloaded chord and rigid portal and sway bracing shall be provided in all trusses having sufficient headroom. Outrigger bracing connected to extensions of the floorbeams shall be used for bracing through-trusses having insufficient headroom for a top chord lateral bracing system.

8.12—CAMBER REQUIREMENTS**8.12.1—Glued Laminated Timber Girders**

Glued laminated timber girders shall be cambered a minimum of two times the dead load deflection at the service limit state.

8.12.2—Trusses

Trusses shall be cambered to sufficiently offset the deflection due to dead load, shrinkage, and creep.

8.12.3—Stress Laminated Timber Deck Bridge

Deck bridges shall be cambered for three times the dead load deflection at the service limit state.

8.13—CONNECTION DESIGN

The design of timber connections using mechanical fasteners including, wood screws, nails, bolts, lag screws, drift bolts, drift pins, shear plates, split rings, and timber rivets shall be in accordance with the 2005 *NDS*[®].

8.14—REFERENCES

AF&PA. 2005. *National Design Specification*[®] (*NDS*[®]) *for Wood Construction*. American Forest and Paper Association, Washington, DC.

AITC. 1996. *Standard Specifications for Structural Glued Laminated Timber of Hardwood Species*, AITC 119-96. American Institute of Timber Construction, Centennial, CO.

AITC. 2001. *Standard Appearance Grades for Structural Glued Laminated Timber*, AITC 110-2001. American Institute of Timber Construction, Centennial, CO.

C8.11.3

Bracing should be placed tight against the girders and perpendicular to the longitudinal girder axis.

C8.11.4

Bracing is used to provide resistance to lateral forces, to hold the trusses plumb and true, and to hold compression elements in line.

C8.12.1

The initial camber offsets the effects of dead load deflection and long-term creep deflection.

C8.12.2

Camber should be determined by considering both elastic deformations due to applied loads and inelastic deformations such as those caused by joint slippage, creep of the timber components, or shrinkage due to moisture changes in the wood components.

AITC. 2002. *Structural Glued Laminated Timber*, ANSI/AITC A190.1. American Institute of Timber Construction, Centennial, CO.

AITC. 2004. *Standard Specifications for Structural Glued Laminated Timber of Softwood Species*, AITC 117-2004. American Institute of Timber Construction, Centennial, CO.

Davids, W. G., M. Richie, and C. Gamache. 2005. "Fatigue of Glulam Beams with Fiber-Reinforced Polymer Tension Reinforcing," *Forest Products Journal*. Forest Products Society, Madison, WI, Vol. 55, No. 1.

Davids, W. G., E. Nagy, and M. Richie. 2008. "Fatigue Behavior of Composite-Reinforced Glulam Bridge Girders," *Journal of Bridge Engineering*. American Society of Civil Engineers, Reston, VA, March/April 2008.

ICC-ES. 2005. *Acceptance Criteria for Fiber-Reinforced-Polymer Glue-Laminated Timber Using Mechanics Based Models*, AC280. ICC Evaluation Service, Inc., Whittier, CA.

Lindyberg, R. L. 2000. *ReLAM: A Nonlinear Probabilistic Model for the Analysis of Reinforced Glulam Beams in Bending*, Document ID CIE2000-001. Dissertation. University of Maine, Orono, ME.

Nowak, A. S. 1997. *Load Distribution for Plank Decks*, UMCEE 97-11. Report submitted to U.S. Forest Service, U.S. Department of Agriculture, Washington, DC, April 1997.

Nowak, A. S. 1999. *Calibration of LRFD Bridge Design Code*, NCHRP Report 368. Transportation Research Board, National Research Council, Washington, DC.

Nowak, A. S., C. Eamon, M. A. Ritter, and J. Murphy. 2001. *LRFD Calibration for Wood Bridges*, UMCEE 01-01. Report submitted to U.S. Forest Service, U.S. Department of Agriculture, Washington, DC, April 2001.

Nowak, A. S., P. R. Stankiewicz, and M. A. Ritter. 1999. "Bending Tests of Bridge Deck Planks." *Construction and Building Materials Journal*, Vol. 13, No. 4, pp. 221–228.

Ritter, M. A. 1990. *Timber Bridges, Design, Construction, Inspection, and Maintenance*, EM7700-B. U.S. Forest Service, U.S. Department of Agriculture, Washington, DC.

Stankiewicz, P. R., and A. S. Nowak. 1997. *Material Testing for Wood Plank Decks*, UMCEE 97-10. Report submitted to U.S. Forest Service, U.S. Department of Agriculture, Washington, DC, April 1997.

SECTION 9: DECKS AND DECK SYSTEMS

TABLE OF CONTENTS

9.1—SCOPE 9-1

9.2—DEFINITIONS 9-1

9.3—NOTATION 9-4

9.4—GENERAL DESIGN REQUIREMENTS 9-4

 9.4.1—Interface Action 9-4

 9.4.2—Deck Drainage 9-4

 9.4.3—Concrete Appurtenances 9-5

 9.4.4—Edge Supports 9-5

 9.4.5—Stay-in-Place Formwork for Overhangs 9-5

9.5—LIMIT STATES 9-5

 9.5.1—General 9-5

 9.5.2—Service Limit States 9-5

 9.5.3—Fatigue and Fracture Limit State 9-6

 9.5.4—Strength Limit States 9-6

 9.5.5—Extreme Event Limit States 9-6

9.6—ANALYSIS 9-6

 9.6.1—Methods of Analysis 9-6

 9.6.2—Loading 9-6

9.7—CONCRETE DECK SLABS 9-7

 9.7.1—General 9-7

 9.7.1.1—Minimum Depth and Cover 9-7

 9.7.1.2—Composite Action 9-7

 9.7.1.3—Skewed Decks 9-7

 9.7.1.4—Edge Support 9-8

 9.7.1.5—Design of Cantilever Slabs 9-8

 9.7.2—Empirical Design 9-8

 9.7.2.1—General 9-8

 9.7.2.2—Application 9-9

 9.7.2.3—Effective Length 9-9

 9.7.2.4—Design Conditions 9-10

 9.7.2.5—Reinforcement Requirements 9-11

 9.7.2.6—Deck with Stay-in-Place Formwork 9-12

 9.7.3—Traditional Design 9-12

 9.7.3.1—General 9-12

 9.7.3.2—Distribution Reinforcement 9-12

 9.7.4—Stay-in-Place Formwork 9-13

 9.7.4.1—General 9-13

 9.7.4.2—Steel Formwork 9-13

 9.7.4.3—Concrete Formwork 9-13

 9.7.4.3.1—Depth 9-13

9.7.4.3.2—Reinforcement	9-13
9.7.4.3.3—Creep and Shrinkage Control	9-14
9.7.4.3.4—Bedding of Panels	9-14
9.7.5—Precast Deck Slabs on Girders	9-14
9.7.5.1—General	9-14
9.7.5.2—Transversely Joined Precast Decks	9-14
9.7.5.3—Longitudinally Post-Tensioned Precast Decks	9-15
9.7.6—Deck Slabs in Segmental Construction	9-15
9.7.6.1—General	9-15
9.7.6.2—Joints in Decks	9-15
9.8—METAL DECKS	9-15
9.8.1—General	9-15
9.8.2—Metal Grid Decks	9-16
9.8.2.1—General	9-16
9.8.2.2—Open Grid Floors	9-16
9.8.2.3—Filled and Partially Filled Grid Decks	9-17
9.8.2.3.1—General	9-17
9.8.2.3.2—Design Requirements	9-17
9.8.2.3.3—Fatigue and Fracture Limit State	9-18
9.8.2.4—Unfilled Grid Decks Composite with Reinforced Concrete Slabs	9-18
9.8.2.4.1—General	9-18
9.8.2.4.2—Design	9-19
9.8.2.4.3—Fatigue Limit State	9-19
9.8.3—Orthotropic Steel Decks	9-20
9.8.3.1—General	9-20
9.8.3.2—Wheel Load Distribution	9-20
9.8.3.3—Wearing Surface	9-20
9.8.3.4—Analysis of Orthotropic Decks	9-21
9.8.3.4.1—General	9-21
9.8.3.4.2—Level 1 Design	9-23
9.8.3.4.3—Level 2 Design	9-23
9.8.3.4.3a—General	9-23
9.8.3.4.3b—Decks with Open Ribs	9-24
9.8.3.4.3c—Decks with Closed Ribs	9-24
9.8.3.4.4—Level 3 Design	9-24
9.8.3.5—Design	9-25
9.8.3.5.1—Superposition of Local and Global Effects	9-25
9.8.3.5.2—Limit States	9-25
9.8.3.5.2a—General	9-25
9.8.3.5.2b—Service Limit State	9-26
9.8.3.5.2c—Strength Limit State	9-26
9.8.3.5.2d—Fatigue Limit State	9-26
9.8.3.6—Detailing Requirements	9-26
9.8.3.6.1—Minimum Plate Thickness	9-26
9.8.3.6.2—Limit States	9-27
9.8.3.6.2a—General	9-27

9.8.3.6.2b—Service Limit State	9-27
9.8.3.6.2c—Strength Limit State	9-27
9.8.3.6.2d—Fatigue Limit State	9-27
9.8.3.6.3—Welding to Orthotropic Decks	9-28
9.8.3.6.4—Deck and Rib Details	9-28
9.8.3.7—Detailing Requirements	9-29
9.8.3.7.1—Minimum Plate Thickness	9-29
9.8.3.7.2—Closed Ribs	9-29
9.8.3.7.3—Welding to Orthotropic Decks	9-30
9.8.3.7.4—Deck and Rib Details	9-30
9.8.4—Orthotropic Aluminum Decks	9-31
9.8.4.1—General	9-31
9.8.4.2—Approximate Analysis	9-31
9.8.4.3—Limit States	9-31
9.8.5—Corrugated Metal Decks	9-32
9.8.5.1—General	9-32
9.8.5.2—Distribution of Wheel Loads	9-32
9.8.5.3—Composite Action	9-32
9.9—WOOD DECKS AND DECK SYSTEMS	9-32
9.9.1—Scope	9-32
9.9.2—General	9-32
9.9.3—Design Requirements	9-32
9.9.3.1—Load Distribution	9-32
9.9.3.2—Shear Design	9-33
9.9.3.3—Deformation	9-33
9.9.3.4—Thermal Expansion	9-33
9.9.3.5—Wearing Surfaces	9-33
9.9.3.6—Skewed Decks	9-33
9.9.4—Glued Laminated Decks	9-34
9.9.4.1—General	9-34
9.9.4.2—Deck Tie-Downs	9-34
9.9.4.3—Interconnected Decks	9-34
9.9.4.3.1—Panels Parallel to Traffic	9-34
9.9.4.3.2—Panels Perpendicular to Traffic	9-34
9.9.4.4—Noninterconnected Decks	9-35
9.9.5—Stress Laminated Decks	9-35
9.9.5.1—General	9-35
9.9.5.2—Nailing	9-35
9.9.5.3—Staggered Butt Joints	9-36
9.9.5.4—Holes in Laminations	9-36
9.9.5.5—Deck Tie-Downs	9-36
9.9.5.6—Stressing	9-36
9.9.5.6.1—Prestressing System	9-36
9.9.5.6.2—Prestressing Materials	9-38
9.9.5.6.3—Design Requirements	9-39
9.9.5.6.4—Corrosion Protection	9-40

9.9.5.6.5—Railings	9-40
9.9.6—Spike Laminated Decks	9-40
9.9.6.1—General	9-40
9.9.6.2—Deck Tie-Downs	9-41
9.9.6.3—Panel Decks	9-41
9.9.7—Plank Decks	9-42
9.9.7.1—General	9-42
9.9.7.2—Deck Tie-Downs	9-42
9.9.8—Wearing Surfaces for Wood Decks	9-42
9.9.8.1—General	9-42
9.9.8.2—Plant Mix Asphalt	9-42
9.9.8.3—Chip Seal	9-43
9.10—REFERENCES	9-43

SECTION 9

DECKS AND DECK SYSTEMS

9.1—SCOPE

This Section contains provisions for the analysis and design of bridge decks and deck systems of concrete, metal, and wood or combinations thereof subjected to gravity loads.

For monolithic concrete bridge decks satisfying specific conditions, an empirical design, requiring no analysis, is permitted.

Continuity in the deck and its supporting components is encouraged.

Composite action between the deck and its supporting components is required where technically feasible.

9.2—DEFINITIONS

Appurtenance—Curbs, parapets, railings, barriers, dividers, and sign and lighting posts attached to the deck.

Arching Action—A structural phenomenon in which wheel loads are transmitted primarily by compressive struts formed in the slab.

Band—A strip of laminated wood deck within which the pattern of butt joints is not repeated.

Bolster—A spacer between a metal deck and a beam.

Bulkhead—A steel element attached to the side of stress laminated timber decks to distribute the prestressing force and reduce the tendency to crush the wood.

Cellular Deck—A concrete deck with void-ratio in excess of 40 percent.

Clear Span—The face-to-face distance between supporting components.

Closed Rib—A rib in an orthotropic deck consisting of a plate forming a trough, welded to the deck plate along both sides of the rib.

Closure Joint—A cast-in-place concrete fill between precast components to provide continuity.

Compatibility—The equality of deformation at the interface of elements and/or components joined together.

Component—A structural element or combination of elements requiring individual design consideration.

Composite Action—A condition in which two or more elements or components are made to act together by preventing relative movement at their interface.

Continuity—In decks, both structural continuity and the ability to prevent water penetration without the assistance of nonstructural elements.

Core Depth—The distance between the top of top reinforcement and the bottom of bottom reinforcement in a concrete slab.

Deck—A component, with or without wearing surface, that supports wheel loads directly and is supported by other components.

Deck Joint—A complete or partial interruption of the deck to accommodate relative movement between portions of a structure.

C9.1

Implicit in this Section is a design philosophy that prefers jointless, continuous bridge decks and deck systems to improve the weather and corrosion-resisting effects of the whole bridge, reduce inspection efforts and maintenance costs, and increase structural effectiveness and redundancy.

Deck System—A superstructure, in which the deck is integral with its supporting components, or in which the effects or deformation of supporting components on the behavior of the deck is significant.

Design Span—For decks, the center-to-center distance between the adjacent supporting components, taken in the primary direction.

Effective Length—The span length used in the empirical design of concrete slabs defined in Article 9.7.2.3.

Elastic—A structural response in which stress is directly proportional to strain and no deformation remains upon removal of loading.

Equilibrium—A state where the sum of forces parallel to any axis and the sum of moments about any axis in space are 0.0.

Equivalent Strip—An artificial linear element, isolated from a deck for the purpose of analysis, in which extreme force effects calculated for a line of wheel loads, transverse or longitudinal, will approximate those actually taking place in the deck.

Extreme—Maximum or minimum.

Flexural Continuity—The ability to transmit moment and rotation between components or within a component.

Floorbeam—The traditional name for a cross-beam.

Footprint—The specified contact area between wheel and roadway surface.

Frame Action—Transverse continuity between the deck and the webs of cellular cross-section or between the deck and primary components in large bridges.

Glued Laminated Deck Panel—A deck panel made from wood laminations connected by adhesives.

Governing Position—The location and orientation of a transient load to cause extreme force effects.

Inelastic—The structural response in which stress is not directly proportional to strain and deformation may remain upon removal of loading.

Interface—The location where two elements and/or components are in contact.

Internal Composite Action—The interaction between a deck and a structural overlay.

Isotropic Plate—A plate having essentially identical structural properties in the two principal directions.

Isotropic Reinforcement—Two identical layers of reinforcement, perpendicular to and in touch with each other.

Lateral—Any horizontal or close to horizontal direction.

Laminated Deck—A deck consisting of a series of laminated wood elements that are tightly abutted along their edges to form a continuous surface.

Local Analysis—An in-depth study of strains and stresses in or among components using force effects obtained from global analysis.

Net Depth—The depth of concrete, excluding the concrete placed in the corrugations of a metal formwork.

Open Grid Floor—A metal grid floor not filled or covered with concrete.

Open Rib—A rib in an orthotropic deck consisting of a single plate or rolled section welded to the deck plate.

Orthotropic—A plate having significantly different structural properties in the two principal directions.

Overfill—The concrete above the top of the steel grid of filled or partially filled steel grid deck systems.

Partial Composite Action—A condition in which two or more elements or components are made to act together by decreasing, but not eliminating, relative movement at their interface, or where the connecting elements are too flexible to fully develop the deck in composite action.

Primary Direction—In isotropic decks: direction of the shorter span; in orthotropic decks: direction of the main load-carrying elements.

Secondary Direction—The direction normal to the primary direction.

Segmental Construction—A method of building a bridge utilizing match-cast, prefabricated, or cast-in-place concrete segments joined together by longitudinal post-tensioning.

Shear Connector—A mechanical device that prevents relative movements both normal and parallel to an interface.

Shear Continuity—A condition where shear and displacement are transmitted between components or within a component.

Shear Key—A preformed hollow in the side of a precast component filled with grout or a system of match-cast depressions and protrusions in the face of segments that is intended to provide shear continuity between components.

Skew Angle—The angle between the axis of support relative to a line normal to the longitudinal axis of the bridge, i.e., a zero-degree skew denotes a rectangular bridge.

Spacing—Center-to-center distance of elements or components, such as reinforcing bars, girders, bearings, etc.

Stay-in-Place Formwork—Permanent metal or precast concrete forms that remain in place after construction is finished.

Stiffener Beam—An unsupported beam attached to the underside of a wood deck to enhance lateral continuity.

Stress Range—The algebraic difference between extreme stresses.

Structural Overlay—An overlay bonded to the deck that consists of concretes other than asphaltic concretes.

Tandem—Two closely spaced and mechanically interconnected axles of equal weight.

Tie-Down—A mechanical device that prevents relative movement normal to an interface.

Void—An internal discontinuity of the deck by which its self-weight is reduced.

Voided Deck—Concrete deck in which the area of the voids does not constitute more than 40 percent of the gross area.

Wheel—One tire or a pair of tires at one end of an axle.

Wheel Load—One-half of a specified design axle load.

Wearing Surface—An overlay or sacrificial layer of the structural deck to protect the structural deck against wear, road salts, and environmental effects. The overlay may include waterproofing.

Yield Line—A plastic hinge line.

Yield Line Analysis—A method of determining the load-carrying capacity of a component on the basis of the formation of a mechanism.

Yield Line Method—A method of analysis in which a number of possible yield line patterns of concrete slabs are examined in order to determine minimum load-carrying capacity.

9.3—NOTATION

A_B	=	effective bearing area of anchorage bulkhead (in. ²) (9.9.5.6.3)
A_s	=	area of steel bar or strand (in. ²) (9.9.5.6.3)
a	=	larger of the spacing of the rib webs (in.) (9.8.3.6.2)
c	=	depth of the bottom cutout to accommodate a rib in an orthotropic deck (in.) (9.8.3.6.4)
d	=	effective depth: distance between the outside compressive fiber and the center of gravity of the tensile reinforcement (in.) (C9.7.2.5)
e	=	clear spacing between closed ribs in orthotropic steel decks (in.) (9.8.3.6.4)
F	=	nominal bearing resistance of wood across the grain (ksi) (9.9.5.6.3)
f_r	=	the out-of-plane flexural stresses in rib webs (ksi) (C9.8.3.6.2)
h	=	depth of deck (in.) (9.9.5.6.3)
h'	=	length of the inclined portion of the rib web (in.) (9.8.3.6.2)
k	=	factor representing a distribution of bending moment along a rib (C9.8.3.6.2)
L	=	span length from center-to-center of supports (9.5.2)
P_{BU}	=	factored compressive resistance of the wood under the bulkhead (kip) (9.9.5.6.3)
P_{pt}	=	prestressing force per prestressing element (kip) (9.9.5.6.3)
q	=	load intensity (ksi) (C9.8.3.6.2)
R_{sw}	=	steel-wood ratio (9.9.5.6.3)
S	=	effective span length (ft) (9.7.3.2)
s	=	spacing of prestressing bars (in.) (9.9.5.6.3)
t	=	thickness of slab or plate (in.) (9.8.3.6.1)
$t_{d, eff}$	=	effective depth of deck plate, including the stiffening effect of surfacing (in.) (9.8.3.6.2)
t_r	=	thickness of rib web (in.) (9.8.3.6.2)
ϕ	=	resistance factor (9.9.5.6.3)

9.4—GENERAL DESIGN REQUIREMENTS

9.4.1—Interface Action

Decks other than wood and open grid floors shall be made composite with their supporting components, unless there are compelling reasons to the contrary. Noncomposite decks shall be connected to their supporting components to prevent vertical separation.

Shear connectors and other connections between decks, other than open grid floors and wood decks, and their supporting members shall be designed for force effects calculated on the basis of full composite action, whether or not that composite action is considered in proportioning the primary members. The details for transmitting shear across the interface to metal supporting components shall satisfy the applicable provisions of Article 6.6 or Article 7.6.

Force effects between the deck and appurtenances or other components shall be accommodated.

9.4.2—Deck Drainage

With the exception of unfilled steel grid decks, cross and longitudinal slopes of the deck surface shall be provided as specified in Article 2.6.6.

Structural effects of drainage openings shall be considered in the design of decks.

C9.4.1

Composite action is recommended to enhance the stiffness and economy of structures.

Some decks without shear connectors have historically demonstrated a degree of composite action due to chemical bond and/or friction that cannot be accounted for in structural design.

It is difficult to design and detail a tie-down device that does not attract shear forces due to transient loads, temperature changes, and fluctuation in moisture content. These forces may loosen and/or break such devices, and cause fatigue damage in other parts of the floor system and its connections to main members, and to floorbeams in particular.

9.4.3—Concrete Appurtenances

Unless otherwise specified by the Owner, concrete curbs, parapets, barriers, and dividers should be made structurally continuous. Consideration of their structural contribution to the deck should be limited in accordance with the provisions of Article 9.5.1.

9.4.4—Edge Supports

Unless the deck is designed to support wheel loads in extreme positions with respect to its edges, edge supports shall be provided. Nonintegral edge beams shall conform to the provisions of Article 9.7.1.4.

9.4.5—Stay-in-Place Formwork for Overhangs

Stay-in-place formwork, other than that in filled steel decks, shall not be used in the overhang of concrete decks.

9.5—LIMIT STATES**9.5.1—General**

The structural contribution of a concrete appurtenance to the deck may be considered for service and fatigue but not for strength or extreme event limit states.

For other than the deck overhang, where the conditions specified in Article 9.7.2 are met, a concrete deck may be assumed to satisfy service, fatigue, and fracture and strength limit state requirements and need not meet the other provisions of Article 9.5.

9.5.2—Service Limit States

At service limit states, decks and deck systems shall be analyzed as fully elastic structures and shall be designed and detailed to satisfy the provisions of Sections 5, 6, 7, and 8.

The effects of excessive deck deformation, including deflection, shall be considered for metal grid decks and other lightweight metal and concrete bridge decks. For these deck systems, the deflection caused by live load plus dynamic load allowance shall not exceed the following criteria:

- $L/800$ for decks with no pedestrian traffic,
- $L/1000$ for decks with limited pedestrian traffic, and
- $L/1200$ for decks with significant pedestrian traffic

where:

L = span length from center-to-center of supports.

C9.4.3

Experience indicates that the interruption of concrete appurtenances at locations other than deck joints does not serve the intended purpose of stress relief. Large cracks, only a foot or so away from open joints, have been observed in concrete parapets. The structural participation of these components is usually but not always beneficial. One possible negative aspect of continuity is increased cracking in the appurtenance.

C9.4.4

If the deck joint hardware is integrated with the deck, it may be utilized as a structural element of the edge beam.

C9.5.1

Exclusion of contribution of an appurtenance at strength limit state is a safety measure in that advantage is not taken of a component that may be damaged, disconnected, or destroyed by a collision.

Article 9.7.2.2 states that the empirical design method does not apply to overhangs.

C9.5.2

Deck deformation refers to local dishing at wheel loads, not to overall superstructure deformation.

The primary objective of curtailing excessive deck deformation is to prevent breakup and loss of the wearing surface. No overall limit can be specified because such limit is a function of the composition of the wearing surface and the adhesion between the deck and the wearing surface. The limits should be established by testing.

Substantial work has been done relating accelerations to user comfort. Acceleration is a function of the fundamental frequency of vibration of the deck on a particular span, and the magnitude of dynamic deflection due to live load. Dynamic deflections are typically 15 percent to 20 percent of static deflections. Analysis shows that static deflections serve well as a proxy for acceleration levels for deck systems.

9.5.3—Fatigue and Fracture Limit State

Fatigue need not be investigated for:

- Concrete decks, and
- Wood decks as listed in Article 9.9.

Open grid, filled grid, partially filled grid, and unfilled grid decks composite with reinforced concrete slabs shall comply with the provisions of Articles 4.6.2.1, 6.5.3, and 9.8.2.

Steel orthotropic decks shall comply with the provisions of Article 6.5.3. Aluminum decks shall comply with the provisions of Article 7.6.

Concrete decks, other than those in multigirder application, shall be investigated for the fatigue limit states as specified in Article 5.5.3.

9.5.4—Strength Limit States

At strength limit states, decks and deck systems may be analyzed as either elastic or inelastic structures and shall be designed and detailed to satisfy the provisions of Sections 5, 6, 7, and 8.

9.5.5—Extreme Event Limit States

Decks shall be designed for force effects transmitted by traffic and combination railings using loads, analysis procedures, and limit states specified in Section 13. Acceptance testing, complying with Section 13, may be used to satisfy this requirement.

9.6—ANALYSIS**9.6.1—Methods of Analysis**

Approximate elastic methods of analysis specified in Article 4.6.2.1, refined methods specified in Article 4.6.3.2, or the empirical design of concrete slabs specified in Article 9.7 may be used for various limit states as permitted in Article 9.5.

9.6.2—Loading

Loads, load positions, tire contact area, and load combinations shall be in accordance with the provisions of Section 3.

C9.5.3

The provisions that do not require fatigue investigation of certain types of decks are based exclusively on observed performance and laboratory testing.

A series of 35 pulsating load fatigue tests of model slabs indicate that the fatigue limit for the slabs designed by the conventional AASHTO moment methods was approximately three times the service level. Decks based on the isotropic reinforcement method specified in Article 9.7.2 had fatigue limits of approximately twice the service level (deV Batchelor et al., 1978).

C9.5.4

These Specifications do not permit an unlimited application of inelastic methods of analysis due to the lack of adequate background research. There are, however, well-established inelastic plate analyses whose use is allowed.

C9.6.1

Analytical methods presented herein should not be construed as excluding other analytical approaches, provided that they are approved by the Owner.

9.7—CONCRETE DECK SLABS

9.7.1—General

9.7.1.1—Minimum Depth and Cover

Unless approved by the Owner, the depth of a concrete deck, excluding any provision for grinding, grooving, and sacrificial surface, should not be less than 7.0 in.

Minimum cover shall be in accordance with the provisions of Article 5.12.3.

9.7.1.2—Composite Action

Shear connectors shall be designed in accordance with the provisions of Section 5 for concrete beams and Sections 6 and 7 for metal beams.

9.7.1.3—Skewed Decks

If the skew angle of the deck does not exceed 25 degrees, the primary reinforcement may be placed in the direction of the skew; otherwise, it shall be placed perpendicular to the main supporting components.

C9.7.1.1

For slabs of depth less than 1/20 of the design span, consideration should be given to prestressing in the direction of that span in order to control cracking.

Construction tolerances become a concern for thin decks.

Minimum cover requirements are based on traditional concrete mixes and on the absence of protective coating on either the concrete or the steel inside. A combination of special mix design, protective coatings, dry or moderate climate, and the absence of corrosion chemicals may justify a reduction of these requirements provided that the Owner approves.

C9.7.1.2

Some research efforts have dealt with wood beams composite with concrete decks and steel beams with stressed wood decks, but progress is not advanced to a point which permits codification.

C9.7.1.3

The intent of this provision is to prevent extensive cracking of the deck, which may result from the absence of appreciable reinforcement acting in the direction of principal flexural stresses due to a heavily skewed reinforcement, as shown in Figure C9.7.1.3-1. The somewhat arbitrary 25-degree limit could affect the area of steel as much as ten percent. This was not taken into account because the analysis procedure and the use of bending moment as a basis of design were not believed to be sufficiently accurate to warrant such an adjustment. Owners interested in making this refinement should also consider one of the refined methods of analysis identified in Article 4.6.3.2.

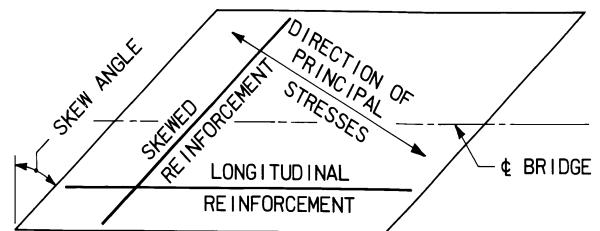

Figure C9.7.1.3-1—Reinforcement Layout

9.7.1.4—Edge Support

Unless otherwise specified, at lines of discontinuity, the edge of the deck shall either be strengthened or be supported by a beam or other line component. The beam or component shall be integrated in or made composite with the deck. The edge beams may be designed as beams whose width may be taken as the effective width of the deck specified in Article 4.6.2.1.4.

Where the primary direction of the deck is transverse, and/or the deck is composite with a structurally continuous concrete barrier, no additional edge beam need be provided.

9.7.1.5—Design of Cantilever Slabs

The overhanging portion of the deck shall be designed for railing impact loads and in accordance with the provisions of Article 3.6.1.3.4.

Punching shear effects at the outside toe of a railing post or barrier due to vehicle collision loads shall be investigated.

9.7.2—Empirical Design

9.7.2.1—General

The provisions of Article 9.7.2 relate exclusively to the empirical design process for concrete deck slabs supported by longitudinal components and shall not be applied to any other Article in this Section, unless specifically permitted.

C9.7.1.5

An acceptable method of analyzing deck overhangs for railing impact loads is presented in the appendix to Section 13.

Any combination of increasing the depth of the slab, employing special reinforcement extending the slab width beyond the railing, and enlarging base plates under railing posts may be utilized to prevent failure due to punching shear.

C9.7.2.1

Extensive research into the behavior of concrete deck slabs discovered that the primary structural action by which these slabs resist concentrated wheel loads is not flexure, as traditionally believed, but a complex internal membrane stress state referred to as internal arching. This action is made possible by the cracking of the concrete in the positive moment region of the design slab and the resulting upward shift of the neutral axis in that portion of the slab. The action is sustained by in-plane membrane forces that develop as a result of lateral confinement provided by the surrounding concrete slab, rigid appurtenances, and supporting components acting compositely with the slab.

The arching creates what can best be described as an internal compressive dome, the failure of which usually occurs as a result of overstraining around the perimeter of the wheel footprint. The resulting failure mode is that of punching shear, although the inclination of the fracture surface is much less than 45 degrees due to the presence of large in-plane compressive forces associated with arching. The arching action, however, cannot resist the full wheel load. There remains a small flexural component for which the specified minimum amount of isotropic reinforcement is more than adequate. The steel has a dual purpose: it provides for both local flexural resistance and global confinement required to develop arching effects (Fang, 1985; Holowka et al., 1980).

The longitudinal bars of the isotropic reinforcement may participate in resisting negative moments at an internal support in continuous structures.

9.7.2.2—Application

Empirical design of reinforced concrete decks may be used if the conditions set forth in Article 9.7.2.4 are satisfied.

The provisions of this Article shall not be applied to overhangs.

The overhang should be designed for:

- Wheel loads for decks with discontinuous railings and barriers using the equivalent strip method,
- Equivalent line load for decks with continuous barriers specified in Article 3.6.1.3.4, and
- Collision loads using a failure mechanism as specified in Article A13.2.

9.7.2.3—Effective Length

For the purpose of the empirical design method, the effective length of slab shall be taken as:

- For slabs monolithic with walls or beams: the face-to-face distance, and
- For slabs supported on steel or concrete girders: the distance between flange tips, plus the flange overhang, taken as the distance from the extreme flange tip to the face of the web, disregarding any fillets.

All available test data indicate that the factor of safety of a deck designed by the flexural method specified in the 16th edition of the AASHTO Standard Specifications, working stress design, is at least 10.0. Tests indicate a comparable factor of safety of about 8.0 for an empirical design. Therefore, even the empirical design possesses an extraordinary reserve strength.

The design of reinforced concrete decks using the concept of internal arching action within the limits specified herein has been verified by extensive nonlinear finite element analysis (Hewitt and deV Batchelor, 1975; Fang et al. 1990). These analyses are accepted in lieu of project-specific design calculation as a preapproved basis of design.

Slabs with the minimum specified reinforcement have demonstrated nearly complete insensitivity to differential displacement among their supports.

The additional longitudinal reinforcement provided for the slab in the negative moment region of continuous beams and girder-type bridges beyond that required for isotropic reinforcement according to the provisions of Article 9.7.2.5 need not be matched in the perpendicular direction. Theoretically, this portion of the deck will be orthotropically reinforced, but this does not weaken the deck.

C9.7.2.2

Although current tests indicated that arching action may exist in the cantilevered overhang of the slab, the available evidence is not sufficient to formulate code provisions for it (Hays et al., 1989).

As indicated in Article 9.5.5, acceptance testing complying with Section 13 may be used to satisfy design requirements for deck overhangs.

C9.7.2.3

Physical tests and analytical investigations indicate that the most important parameter concerning the resistance of concrete slabs to wheel loads is the ratio between the effective length and the depth of the slab.

In case of nonuniform spacing of supporting components, the effective length, $S_{effective}$, shall be taken as the larger of the deck lengths at the two locations shown in Figure 9.7.2.3-1.

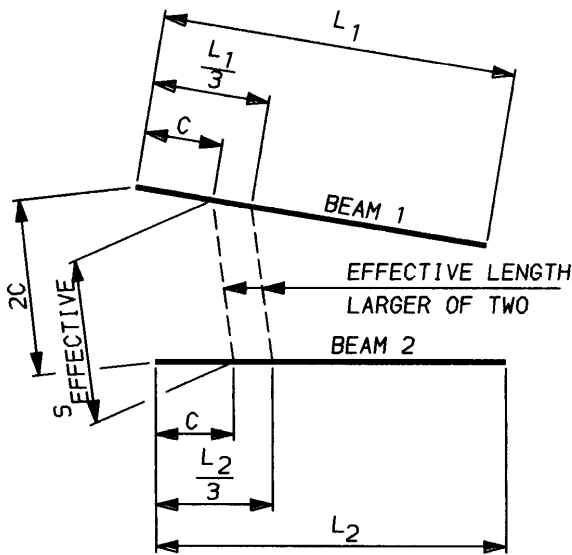

Figure 9.7.2.3-1—Effective Length for Nonuniform Spacing of Beams

9.7.2.4—Design Conditions

For the purpose of this Article, the design depth of the slab shall exclude the loss that is expected to occur as a result of grinding, grooving, or wear.

The empirical design may be used only if the following conditions are satisfied:

- Cross-frames or diaphragms are used throughout the cross-section at lines of support;
- For cross-section involving torsionally stiff units, such as individual separated box beams, either intermediate diaphragms between the boxes are provided at a spacing not to exceed 25.0 ft, or the need for supplemental reinforcement over the webs to accommodate transverse bending between the box units is investigated and reinforcement is provided if necessary;
- The supporting components are made of steel and/or concrete;
- The deck is fully cast-in-place and water cured;
- The deck is of uniform depth, except for haunches at girder flanges and other local thickening;
- The ratio of effective length to design depth does not exceed 18.0 and is not less than 6.0;

C9.7.2.4

Intermediate cross-frames are not needed in order to use the empirical deck design method for cross-sections involving torsionally weak open shapes, such as T- or I-shaped girders.

Use of separated, torsionally stiff beams without intermediate diaphragms can give rise to the situation, shown in Figure C9.7.2.4-1, in which there is a relative displacement between beams and in which the beams do not rotate sufficiently to relieve the moment over the webs. This moment may or may not require more reinforcing than is provided by the empirical deck design.

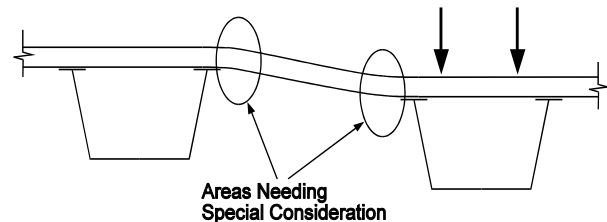

Figure C9.7.2.4-1—Schematic of Effect of Relative Displacements in Torsionally Stiff Cross-Section

All the tests carried out so far were restricted to specimens of uniform depth. Slabs supported by wood beams are not qualified for the empirical design due to the lack of experimental evidence regarding adequate lateral shear transfer between the slab and the relatively soft timber beams.

- Core depth of the slab is not less than 4.0 in.;
- The effective length, as specified in Article 9.7.2.3, does not exceed 13.5 ft;
- The minimum depth of the slab is not less than 7.0 in., excluding a sacrificial wearing surface where applicable;
- There is an overhang beyond the centerline of the outside girder of at least 5.0 times the depth of the slab; this condition is satisfied if the overhang is at least 3.0 times the depth of the slab and a structurally continuous concrete barrier is made composite with the overhang;

- The specified 28-day strength of the deck concrete is not less than 4.0 ksi; and
- The deck is made composite with the supporting structural components.

For the purpose of this Article, a minimum of two shear connectors at 24.0-in. centers shall be provided in the negative moment region of continuous steel superstructures. The provisions of Article 6.10.1.1 shall also be satisfied. For concrete girders, the use of stirrups extending into the deck shall be taken as sufficient to satisfy this requirement.

9.7.2.5—Reinforcement Requirements

Four layers of isotropic reinforcement shall be provided in empirically designed slabs. Reinforcement shall be located as close to the outside surfaces as permitted by cover requirements. Reinforcement shall be provided in each face of the slab with the outermost layers placed in the direction of the effective length. The minimum amount of reinforcement shall be 0.27 in.²/ft of steel for each bottom layer and 0.18 in.²/ft of steel for each top layer. Spacing of steel shall not exceed 18.0 in. Reinforcing steel shall be Grade 60 or better. All reinforcement shall be straight bars, except that hooks may be provided where required.

Both lap splices and mechanical splices shall be allowed. Mechanical splices shall be tested and approved to conform to the limits for slip in Article 5.11.5.2.2, Mechanical Couplers, and for fatigue in Article 5.5.3.4, Welded or Mechanical Splices of Reinforcement. Sleeve wedge-type couplers shall not be permitted on coated reinforcing.

No experience exists for effective lengths exceeding 13.5 ft. The 7.0-in. depth is considered an absolute minimum with 2.0-in. cover on top and 1.0-in. cover on the bottom, providing for a reinforced core of 4.0 in., as indicated in Figure C9.7.2.4-2.

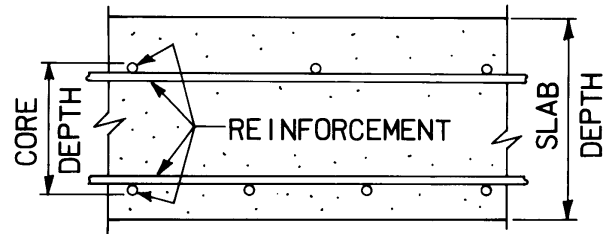

Figure C9.7.2.4-2—Core of a Concrete Slab

The provisions of the *Ontario Highway Bridge Design Code* (1991), based on model test results, do not permit length-to-depth ratios in excess of 15.0. The larger value of 18.0 is based on recent experiments (Hays et al., 1989).

The intention of the overhang provision is to ensure confinement of the slab between the first and the second beam.

The 4.0-ksi limit is based on the fact that none of the tests included concrete with less than 4.0-ksi strength at 28 days. Many jurisdictions specify 4.5-ksi concrete for ensuring reduced permeability of the deck. On the other hand, tests indicate that resistance is not sensitive to the compressive strength, and 3.5 ksi may be accepted with the approval of the Owner.

C9.7.2.5

Prototype tests indicated that 0.2 percent reinforcement in each of four layers based on the effective depth d satisfies strength requirements. However, the conservative value of 0.3 percent of the gross area, which corresponds to about 0.27 in.²/ft in a 7.5-in. slab, is specified for better crack control in the positive moment area. Field measurements show very low stresses in negative moment steel; this is reflected by the 0.18-in.²/ft requirement, which is about 0.2 percent reinforcement steel. The additional intent of this low amount of steel is to prevent spalling of the deck due to corrosion of the bars or wires.

Welded splices are not permitted due to fatigue considerations. Tested and preapproved mechanical splices may be permitted when lapping of reinforcing is not possible or desirable, as often occurs in staged construction and widenings. Sleeve wedge-type couplers will not be permitted on coated reinforcing due to stripping of the coating.

If the skew exceeds 25 degrees, the specified reinforcement in both directions shall be doubled in the end zones of the deck. Each end zone shall be taken as a longitudinal distance equal to the effective length of the slab specified in Article 9.7.2.3.

9.7.2.6—Deck with Stay-in-Place Formwork

For decks made with corrugated metal formwork, the design depth of the slab shall be assumed to be the minimum concrete depth.

Stay-in-place concrete formwork shall not be permitted in conjunction with empirical design of concrete slabs.

9.7.3—Traditional Design

9.7.3.1—General

The provisions of this Article shall apply to concrete slabs that have four layers of reinforcement, two in each direction, and that comply with Article 9.7.1.1.

9.7.3.2—Distribution Reinforcement

Reinforcement shall be placed in the secondary direction in the bottom of slabs as a percentage of the primary reinforcement for positive moment as follows:

- For primary reinforcement parallel to traffic:

$$100/\sqrt{S} \leq 50 \text{ percent}$$

- For primary reinforcement perpendicular to traffic:

$$220/\sqrt{S} \leq 67 \text{ percent}$$

where:

S = the effective span length taken as equal to the effective length specified in Article 9.7.2.3 (ft)

The intent of this provision is crack control. Beam slab bridges with a skew exceeding 25 degrees have shown a tendency to develop torsional cracks due to differential deflections in the end zone (OHBD, 1991). The extent of cracking is usually limited to a width that approximates the effective length.

C9.7.2.6

Concrete in the troughs of the corrugated metal deck is ignored due to lack of evidence that it consistently contributes to the strength of the deck. Reinforcement should not be placed directly on corrugated metal formwork.

The empirical design is based on a radial confinement around the wheel load, which may be weakened by the inherent discontinuity of the bottom reinforcement at the boundaries between formwork panels. Limited tests carried out on flexurally designed slabs with stay-in-place concrete formwork indicate a punching shear failure mode, but somewhat less resistance than that provided by fully cast-in-place slabs. The reason for this decrease is that the discontinuity between the panels intercepts, and thus prevents, the undisturbed formation of the frustum of a cone where punching shear occurs (Buth et al., 1992).

C9.7.3.1

The traditional design is based on flexure. The live load force effect in the slab may be determined using the approximate methods of Article 4.6.2.1 or the refined methods of Article 4.6.3.2.

9.7.4—Stay-in-Place Formwork**9.7.4.1—General**

Stay-in-place formwork shall be designed to be elastic under construction loads. The construction load shall not be taken to be less than the weight of the form and the concrete slab plus 0.050 ksf.

Flexural stresses due to unfactored construction loads shall not exceed:

- 75 percent of the yield strength of steel, or
- 65 percent of the 28-day compressive strength for concrete in compression or the modulus of rupture in tension for prestressed concrete form panels.

The elastic deformation caused by the dead load of the forms, plastic concrete, and reinforcement shall not exceed:

- For form span lengths of 10.0 ft or less, the form span length divided by 180 but not exceeding 0.50 in.; or
- For form span lengths greater than 10.0 ft, the form span length divided by 240 but not exceeding 0.75 in.

9.7.4.2—Steel Formwork

Panels shall be specified to be tied together mechanically at their common edges and fastened to their support. No welding of the steel formwork to the supporting components shall be permitted, unless otherwise shown in the contract documents.

Steel formwork shall not be considered to be composite with a concrete slab.

9.7.4.3—Concrete Formwork*9.7.4.3.1—Depth*

The depth of stay-in-place concrete should neither exceed 55 percent of the depth of the finished deck slab nor be less than 3.5 in.

9.7.4.3.2—Reinforcement

Concrete formwork panels may be prestressed in the direction of the design span.

If the precast formwork is prestressed, the strands may be considered as primary reinforcement in the deck slab.

Transfer and development lengths of the strands shall be investigated for conditions during construction and in service.

C9.7.4.1

The intent of this Article is to prevent excessive sagging of the formwork during construction, which would result in an unanticipated increase in the weight of the concrete slab.

Deflection limits are specified to ensure adequate cover for reinforcing steel and to account for all dead load in the design.

C9.7.4.2

For steel stay-in-place formwork, it has been common to provide an allowance for the weight of the form and additional concrete, with the provision added to the contract documents that if the allowance is exceeded by the Contractor's choice, the Contractor is responsible for showing that the effects on the rest of the bridge are acceptable or providing additional strengthening as needed at no cost to the Owner. The customary allowance has been 0.015 ksf, but this should be reviewed if form spans exceed about 10.0 ft.

C9.7.4.3.1

Thousands of bridges have successfully been built with a depth ratio of 43 percent or somewhat higher; 55 percent is believed to be a practical limit, beyond which cracking of the cast-in-place concrete at the panel interface may be expected.

C9.7.4.3.2

The transfer and development lengths for epoxy-coated strands with alkali-resistant hard particles embedded in the coating may be less than that for uncoated strands. Where epoxy-coated strands are used, this value should be determined by testing.

Prestressing strands and/or reinforcing bars in the precast panel need not be extended into the cast-in-place concrete above the beams.

If used, bottom distribution reinforcement may be placed directly on the top of the panels. Splices in the top primary reinforcement in deck slab shall not be located over the panel joints.

The concrete cover below the strands should not be less than 0.75 in.

9.7.4.3.3—Creep and Shrinkage Control

The age of the panel concrete at the time of placing the cast-in-place concrete shall be such that the difference between the combined shrinkage and creep of the precast panel and the shrinkage of the cast-in-place concrete is minimized.

The upper surface of the panels shall be specified to be roughened in such a manner as to ensure composite action with the cast-in-place concrete.

9.7.4.3.4—Bedding of Panels

The ends of the formwork panels shall be supported on a continuous mortar bed or shall be supported during construction in such a manner that the cast-in-place concrete flows into the space between the panel and the supporting component to form a concrete bedding.

9.7.5—Precast Deck Slabs on Girders

9.7.5.1—General

Both reinforced and prestressed precast concrete slab panels may be used. The depth of the slab, excluding any provision for grinding, grooving, and sacrificial surface, shall not be less than 7.0 in.

9.7.5.2—Transversely Joined Precast Decks

Flexurally discontinuous decks made from precast panels and joined together by shear keys may be used. The design of the shear key and the grout used in the key shall be approved by the Owner. The provisions of Article 9.7.4.3.4 may be applicable for the design of bedding.

Tests indicate no difference between constructions with and without reinforcement extended into the cast-in-place concrete over the beams (Bieschke and Klingner, 1982). The absence of extended reinforcement, however, may affect transverse load distribution due to a lack of positive moment continuity over the beams or may result in reflective cracking at the ends of the panel. In addition to transverse cracking, which usually occurs at the panel joints due to creep and shrinkage, the latter may appear unseemly and/or make the construction of this type of deck questionable where deicing salts are used.

C9.7.4.3.3

The objective of this Article is to minimize interface shear stresses between the precast panel and the cast-in-place concrete and to promote good bond. Normally, no bonding agents and/or mechanical connectors are needed for composite action.

C9.7.4.3.4

Setting screws, bituminous fiber boards, neoprene glands, etc., may be appropriate as temporary supports. In the past, some jurisdictions have had bad experience where prestressed concrete panels were supported only by flexible materials. Creep due to prestress had apparently pulled the panel ends away from cast-in-place concrete. Load was transferred to the flexible panel supports, which compressed, resulting in excessive reflective cracking in the cast-in-place concrete.

C9.7.5.2

The shear keys tend to crack due to wheel loads, warping, and environmental effects, leading to leaking of the keys and decreased shear transfer. The relative movement between adjacent panels tends to crack the overlay, if present. Therefore, this construction is not recommended for the regions where the deck may be exposed to salts.

9.7.5.3—Longitudinally Post-Tensioned Precast Decks

The precast components may be placed on beams and joined together by longitudinal post-tensioning. The minimum average effective prestress shall not be less than 0.25 ksi.

The transverse joint between the components and the block-outs at the coupling of post-tensioning ducts shall be specified to be filled with a nonshrink grout having a minimum compressive strength of 5.0 ksi at 24 hours.

Block-outs shall be provided in the slab around the shear connectors and shall be filled with the same grout upon completion of post-tensioning.

C9.7.5.3

Decks made flexurally continuous by longitudinal post-tensioning are the more preferred solution because they behave monolithically and are expected to require less maintenance on the long-term basis.

The post-tensioning ducts should be located at the center of the slab cross-section. Block-outs should be provided in the joints to permit the splicing of post-tensioning ducts.

Panels should be placed on the girders without mortar or adhesives to permit their movement relative to the girders during prestressing. Panels can be placed directly on the girders or located with the help of shims of inorganic material or other leveling devices. If the panels are not laid directly on the beams, the space therein should be grouted at the same time as the shear connector block-outs.

A variety of shear key formations has been used in the past. Recent prototype tests indicate that a “V” joint may be the easiest to form and to fill.

9.7.6—Deck Slabs in Segmental Construction

9.7.6.1—General

The provisions of this Article shall apply to the top slabs of post-tensioned girders whose cross-sections consist of single or multicell boxes. The slab shall be analyzed in accordance with the provisions of Article 4.6.2.1.6.

9.7.6.2—Joints in Decks

Joints in the decks of precast segmental bridges may be dry joints, epoxied match-cast surfaces, or cast-in-place concrete.

Dry joints should be used only in regions where deicing salts are not applied.

The strength of cast-in-place concrete joints shall not be less than that of the precast concrete. The width of the concrete joint shall permit the development of reinforcement in the joint or coupling of ducts if used, but in no case shall it be less than 12.0 in.

C9.7.6.2

Dry joints in the deck, with or without a nonstructural sealant, have been observed to permit percolation of water due to shrinkage as well as creep and temperature-induced warping of segments. Both epoxied match-cast and cast-in-place concrete joints permitted herein should produce water-tight joints. The 12.0-in. cast-in-place closure joint is believed to provide a better riding profile if the deck is not overlaid.

A combination joint in which only the deck part of a match-cast joint is epoxied should be avoided.

9.8—METAL DECKS

9.8.1—General

Metal decks shall be designed to satisfy the requirements of Sections 6 and 7. The tire contact area shall be determined as specified in Article 3.6.1.2.5.

9.8.2—Metal Grid Decks

9.8.2.1—General

Grid deck shall be composed of main elements that span between beams, stringers, or cross-beams and secondary members that interconnect and span between the main elements. The main and secondary elements may form a rectangular or diagonal pattern and shall be securely joined together. All intersections of elements in open grid floors, partially filled grid decks, and unfilled grid decks composite with reinforced concrete slabs shall be welded.

Force effects may be determined using one of the following methods:

- The approximate methods specified in Article 4.6.2.1, as applicable;
- Orthotropic plate theory;
- Equivalent grillage; or
- Design aids provided by the manufacturers, if the performance of the deck is documented and supported by sufficient technical evidence.

One of the accepted approximate methods is based on transformed cross-section area. Mechanical shear transfer devices, including indentations, embossment, sand coating of surface, and other appropriate means may be used to enhance the composite action between elements of the grid and the concrete fill.

If a filled or partially filled grid deck, or an unfilled grid deck composite with reinforced concrete slab is considered to be composite with its supporting members for the purpose of designing those members, the effective width of slab in composite section shall be as specified in Article 4.6.2.6.1.

9.8.2.2—Open Grid Floors

Open grid floors shall be connected to the supporting components by welding or by mechanically fastening at each main element. Where welding is used to make this connection, a single-sided 3.0-in. long weld or a 1.5-in. weld on each side of the main element may be used.

C9.8.2.1

Research has shown that welds between elements in partially filled grids “may be very important to the survival of the cross bar” (Gangarao et al., 1992).

Laboratory tests have shown that section properties of filled and partially filled grids, computed by the transformed area method, are conservative (Gangarao et al., 1992). Tests have also demonstrated that a monolithic concrete overpour may be considered fully effective in determining section properties.

Filled and partially filled grid decks and unfilled grid decks composite with reinforced concrete slabs have better potential for composite action with the supporting components due to their considerable in-plane rigidity.

In computing section properties, omit any effect of concrete in tension (i.e., below the neutral axis in positive bending, and above the neutral axis in negative bending).

The modular ratios may be applied to the composite action of concrete fill with grid deck in flexure and to the composite action between the deck and its supporting beams.

Field tests of systems consisting of unfilled grid decks composite with reinforced concrete slabs and stringers or floorbeams demonstrate significant levels of composite action, with the effective width being at least 12.0 times the overall thickness of the deck, including the grid portion and the structural reinforced concrete slab.

C9.8.2.2

Long-term experience indicates that even where there is an apparently insignificant degree of composite action between the deck and its supporting components, high stresses may develop at their interface, resulting in local failures and separation of the deck. Therefore, the

Unless evidence is provided to the contrary, welding within open grid floors should be considered as a Category E detail, and the provisions of Article 6.6 shall apply.

Ends and edges of open grid floors that may be exposed to vehicular traffic shall be supported by closure bars or other effective means.

9.8.2.3—Filled and Partially Filled Grid Decks

9.8.2.3.1—General

These decks shall consist of a metal grid or other metal structural system filled either completely or partially with concrete.

The provisions of Article 9.8.2.1 shall apply to filled and partially filled grid decks.

Where possible, a 1.75-in. thick structural overfill should be provided.

Filled and partially filled grids shall be attached to supporting components by welding or shear studs to transfer shear between the two surfaces.

requirement to connect at each intersection of a main bar, as indicated, applies even to open grid floors.

C9.8.2.3.1

Full-scale tests on systems consisting of partially filled grid decks and stringers demonstrated significant levels of composite action, with the effective width being at least 12.0 times the depth of the deck. Under load, the deck strain readings across the width of the deck were nearly uniform, with extremely small slip recorded at the deck-stringer interface.

In order to activate the deck in composite action, large shear forces need be resisted at the interface. A preferred method of shear transfer is by welded studs encased in a concrete haunch, similar to that illustrated in Figure C9.8.2.3.1-1.

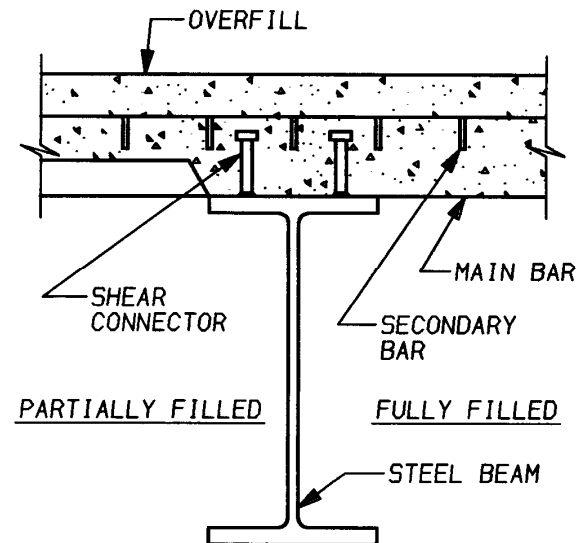

Figure C9.8.2.3.1-1—An Acceptable Shear Connection of Partially and Fully Filled Grid Decks to Beams

9.8.2.3.2—Design Requirements

Design of filled and partially filled grid decks shall be in accordance with the provisions of Article 9.8.2.1 and Article 4.6.2.1.8.

C9.8.2.3.2

The presence of a composite structural overlay improves both the structural performance and riding quality of the deck.

The concrete portion of filled and partially filled grid decks shall be in accordance with the general provisions of Section 5 relating to long-term durability and integrity.

For cast-in-place applications, weight of concrete fill shall be assumed to be carried solely by the metal portion of the deck. The transient loads and superimposed permanent loads may be assumed to be supported by the grid bars and concrete fill acting compositely. A structural overfill may be considered as part of the composite structural deck. Where a structural overfill is provided, the design depth of the deck shall be reduced by a provision for loss that is expected as a result of grinding, grooving, or wear of the concrete.

9.8.2.3.3—Fatigue and Fracture Limit State

All connections among the elements of the steel grid in a fully filled grid deck or the connections within the concrete fill of a partially filled grid deck need not be investigated for fatigue in the local negative moment region of the deck (e.g., negative moment in the deck over a longitudinal stringer or floorbeam) when the deck is designed with a continuity factor of 1.0.

C9.8.2.3.3

Fully filled and partially filled steel grid decks must be checked for fatigue only in the positive moment region (mid span of the deck). However, the deck fatigue moment should be calculated for a simple span configuration ($C = 1.0$) regardless of the actual span configuration.

The fatigue category to be used for fatigue investigation should be determined by appropriate laboratory testing in positive and negative bending. The fatigue category for welds and punchouts shall not be taken as better than Category C, which has been shown by testing to be appropriate for most details of grid decks constructed with concrete.

The small fillet welds used in the fabrication of grid decks are generally less than 1.5 in. long, but are not considered “tack welds.” In grid decks, “tack welds” refers only to small welds used to attach sheet metal pans that serve only as forms for concrete poured onto or into the grid.

Where possible, form pans should be attached by means other than tack welding.

9.8.2.4—Unfilled Grid Decks Composite with Reinforced Concrete Slabs

9.8.2.4.1—General

An unfilled grid deck composite with reinforced concrete slab consists of a reinforced concrete slab that is cast on top of and is composite with an unfilled steel grid. Composite action between the concrete slab and the grid deck shall be ensured by providing shear connectors or other means capable of resisting horizontal and vertical components of interface shears.

Composite action between the grid deck and the supporting components should be ensured by mechanical shear connectors.

Unless otherwise specified, provisions of Article 9.8.2.1 shall apply.

Discontinuities and cold joints in such decks should be kept to a minimum.

C9.8.2.4.1

This bridge deck combines the attributes of a concrete deck and a steel grid deck.

An acceptable way of providing composite action between the deck and the supporting components is shown in Figure C9.8.2.4.1-1.

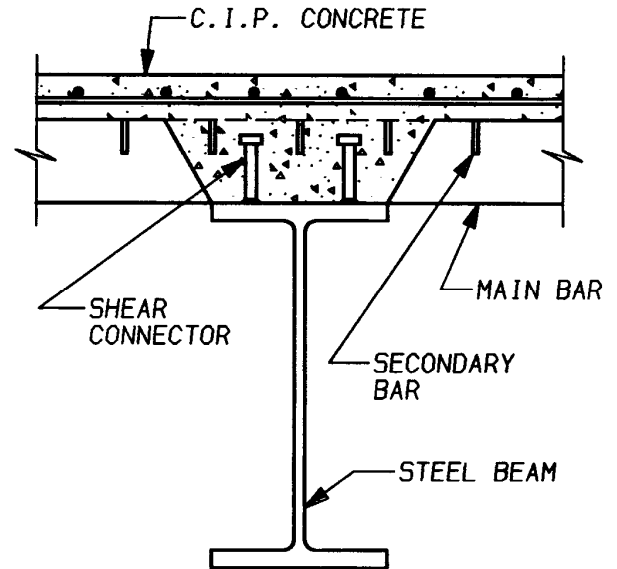

Figure C9.8.2.4.1-1—An Acceptable Shear Connection of Unfilled Grid Decks Composite with Reinforced Concrete Slabs to Beams

9.8.2.4.2—Design

Design of unfilled grid decks composite with reinforced concrete slabs shall be in accordance with the provisions of Article 9.8.2.1 and Article 4.6.2.1.8. The design depth of the deck shall be reduced by a provision for loss that is expected as a result of grinding, grooving, or wear of the concrete.

The reinforced concrete portion of unfilled grid decks composite with reinforced concrete slabs shall be in accordance with the general provisions of Section 5 relating to long-term durability and integrity.

In the concrete slab, one layer of reinforcement in each principal direction may be used.

For cast-in-place applications, weight of concrete slab shall be assumed to be carried solely by the grid portion of the deck. The transient loads and superimposed permanent loads may be assumed to be supported by the composite section.

The interface between the concrete slab and the metal system shall satisfy the provisions of Article 6.10.10. Acceptable methods of shear connection shall include tertiary bars to which 0.5-in. diameter rebar or round studs have been welded, or the punching of holes at least 0.75 in. in size in the top portion of the main bars of the grid which are embedded in the reinforced concrete slab by a minimum of 1.0 in.

9.8.2.4.3—Fatigue Limit State

The internal connection between the elements of the steel grid in unfilled grid decks composite with reinforced concrete slabs shall be investigated for fatigue.

C9.8.2.4.2

For the purpose of design, the deck can be subdivided into intersecting sets of composite concrete/steel beams.

C9.8.2.4.3

The fatigue category to be used for fatigue investigation should be determined by appropriate laboratory testing in positive and negative bending. The fatigue category for welds and punchouts shall not be

Unless evidence is provided to the contrary, tack welds attaching horizontal form pans to metal grids shall be considered Category E' details.

The composite reinforced concrete slab shall be included in the calculation of stress range.

better than Category C, which has been shown by testing to be appropriate for most details of grid decks constructed with concrete.

The small fillet welds used in the fabrication of grid decks are generally less than 1.5 in. long, but are not considered "tack welds." In grid decks, "tack welds" refers only to small welds used to attach sheet metal pans that serve only as forms for concrete poured onto or into the grid.

Where possible, form pans should be attached by means other than tack welding.

9.8.3—Orthotropic Steel Decks

9.8.3.1—General

Orthotropic steel decks shall consist of a deck plate stiffened and supported by longitudinal ribs and transverse floorbeams. The deck plate shall act as a common flange of the ribs, the floorbeams, and the main longitudinal components of the bridge.

In rehabilitation, if the orthotropic deck is supported by existing floorbeams, the connection between the deck and the floorbeam should be designed for full composite action, even if the effect of composite action is neglected in the design of floorbeams. Where practical, connections suitable to develop composite action between the deck and the main longitudinal components should be provided.

9.8.3.2—Wheel Load Distribution

A 45-degree distribution of the tire pressure may be assumed to occur in all directions from the surface contact area to the middle of the deck plate. The tire footprint shall be as specified in Article 3.6.1.2.5.

9.8.3.3—Wearing Surface

The wearing surface should be regarded as an integral part of the total orthotropic deck system and shall be specified to be bonded to the top of the deck plate.

The contribution of a wearing surface to the stiffness of the members of an orthotropic deck may be considered if structural and bonding properties are satisfactorily demonstrated over the temperature range of -20° to $+120^{\circ}$ F. If the contribution of the wearing surface to stiffness is considered in the design, the required engineering properties of the wearing surface shall be indicated in the contract documents.

Force effects in the wearing surface and at the interface with the deck plate shall be investigated with consideration of engineering properties of the wearing surface at anticipated extreme service temperatures.

The long-term composite action between deck plate and wearing surface shall be documented by both static and cyclic load tests.

C9.8.3.1

The intent of this Article is to ensure the structural integrity of the deck and its structural participation with the cross-beams and the primary longitudinal components, as appropriate. Any structural arrangement in which the orthotropic deck is made to act independently from the main components is undesirable.

C9.8.3.2

The 45-degree distribution is the traditional, conservative assumption.

C9.8.3.3

Wearing surfaces acting compositely with the deck plate may reduce deformations and stresses in orthotropic decks.

The deck stiffening effect of the wearing surface is dependent upon its thickness, the elastic modulus which is dependent on temperature and the load application, i.e., static or dynamic, and bond characteristics.

The combination of temperature and live load effects has resulted in debonding of some wearing surfaces in the field, which should be regarded as failure of the wearing surface. The Designer should consider past experience in selection of a wearing surface and in determination of its long-term contribution to the structural system.

Wearing surface cracking is related to stresses exceeding tensile strength of surfacing material. Flexural stresses in surfacing may be reduced by limiting local deflexibility, as indicated in Article 2.5.2.6.2. Safety against surfacing cracking may be best assured by using surfacing materials with semiplastic properties or with low elastic modulus not subject to much variation with temperature.

For the purpose of designing the wearing surface and its adhesion to the deck plate, the wearing surface shall be assumed to be composite with the deck plate, regardless of whether the deck plate is designed on that basis.

The wearing surface plays an important role in improving skid resistance, distributing wheel loads, and protecting the deck against corrosion and abuse.

Selection or design of a wearing surface should include evaluation of the following functional requirements:

- Sufficient ductility and strength to accommodate expansion, contraction, and imposed deformation without cracking or debonding;
- Sufficient fatigue strength to withstand flexural stresses due to composite action of the wearing surface with the deck plate resulting from local flexure;
- Sufficient durability to resist rutting, shoving, and wearing;
- Imperviousness to water and motor vehicle fuels and oils;
- Resistance to deterioration from deicing salts; and
- Resistance to aging and deterioration due to solar radiation.

9.8.3.4—Analysis of Orthotropic Decks

9.8.3.4.1—General

Design of orthotropic decks shall be based on appropriate use of the three levels of analysis specified herein. The fatigue limit state shall be investigated using at least one of the three levels of design specified in Articles 9.8.3.4.2 through 9.8.3.4.4. Strength service and extreme event limit states, as appropriate, and constructability criteria shall be investigated using Level 2 design.

C9.8.3.4.1

The updated design approach for orthotropic deck bridges is based on the following considerations:

- Simplified methods do not currently exist which can evaluate the fatigue limit state at all fatigue-sensitive details,
- Design cannot be accomplished by detailing requirements alone due to a lack of tested and established standard deck panel details,
- Refined analysis for new designs will add engineering cost and potentially limit use for routine span arrangements, and
- Verification testing of every design adds unnecessary cost and has the potential to delay construction.

Hence, design verification of orthotropic steel bridge decks requires a new approach. Since many of the controlling aspects of orthotropic deck panel design are local rather than global demands, a well-designed and detailed panel has the potential to be reused in future applications and become a standardized modular component. Therefore, the required effort for design can vary depending on the application and available test data. These different levels of required effort for design or design levels are summarized as follows:

- Level 1 design is based on little or no structural analysis but is done by selection of details that are verified to have adequate resistance by experimental testing (new or previous). When appropriate laboratory tests have been conducted for previous projects or on specimens similar in design and details to those proposed for a new project, the previous tests may be used as the basis for the design on the new project. All details must provide a level of safety consistent with the AASHTO specifications.
- Level 2 design is based on simplified one-dimensional or two-dimensional analysis of certain panel details where such analysis is sufficiently accurate or for certain details that are similar to previous tested details as described in Level 1. Calculations consider only nominal stresses and not local stress concentrations. This is primarily intended to allow incremental improvement of previously tested details as verified by Level 1. Approximate analysis of both open rib and closed rib decks may be based on the Pelikan-Esslinger method presented by Wolchuck (1963) and Troitsky (1987). This method gives conservative values of global force effects in the orthotropic deck supported on longitudinal edge girders. Load distribution of adjacent transversely located wheel loads on decks with closed ribs is discussed in Wolchuck (1963).
- Level 3 design is based on refined three-dimensional analysis of the panel to quantify the local stresses to the most accurate extent reasonably expected from a qualified design engineer experienced in refined analysis. Level 3 designs will be dictated by the requirements to provide safety against fatigue failure. If no test data is available for a panel, design Level 3 is required unless it can be proven that the local distortional mechanisms (floorbeam distortion and rib distortion) will not lead to fatigue cracking. For design of panels for bridge redecking applications, design Level 3 should always be used unless an exception is approved by the Owner.

Level 3 design is an extension of current AASHTO methodology for fatigue evaluation by nominal stresses. The proposed Level 3 design method is also a similar methodology applied by the American Petroleum Institute (API) and American Welding Society (AWS, 2004) and is well documented by the International Institute of Welding (IIW, 2007). It is used extensively for the fatigue evaluation of tubular structures and plate-type structures with complex geometries by various industries, where there is no clearly defined nominal stress due to complicated geometric effects, conditions very similar to orthotropic deck details. This approach recognizes that fatigue damage is caused by stress raisers that exist at details and attempts to quantify them by

refined analysis rather than accounting for the stresses risers using classification into general categories.

Research has demonstrated that evaluating the local structural stress and evaluating the stress range with AASHTO Category C provides a reliably conservative assessment of the weld toe cracks at orthotropic deck panel welded joints subjected to distortional stresses. The AASHTO Category C curve is similar to the curves provided in the Eurocode (ECS, 1992) and IIW (2007) for evaluation of welded details. Furthermore, research by Dexter et al. (1994) found that the AASHTO Category C curve provides the 97.5 percent survival lower bound for welded details on flexible plates subjected to combined in-plane and out-of-plane stresses in all cases where local stress measured 5 mm from weld toe was used for the fatigue life stress range. The work by Connor and Fisher (2006) also found similar results. This approach is predicated on the modeling and stress analysis being conducted by the method prescribed by Level 3 design.

The procedures for calculating local structural stress for welded connections are representative of a mesh sizing where the length and width of each individual shell or solid element is equivalent to the thickness (t) of the connected component. For modeling with other mesh spacing, different procedures are required for extrapolation of the local structural stress and are presented in more detail in *Recommendations for Fatigue Design of Welded Joints and Components* (IIW, 2007) and *Manual for Design, Construction, and Maintenance of Orthotropic Steel Bridges* (in development).

9.8.3.4.2—Level 1 Design

Orthotropic deck panels and details verified by appropriate full-scale laboratory testing may be used without consideration of design Levels 2 and 3 provided the testing protocol envelopes the structural design loads and stresses for the new application. Test loading should be equivalent to the maximum truck load; stress ranges at details should accurately simulate expected in service demands and should have accurate boundary conditions. For finite fatigue life design, the resistance shall provide 97.5 percent confidence of survival. For infinite fatigue life design, the constant amplitude fatigue limit (CAFL) should be exceeded no more than one in 10,000 cycles (0.01 percent). Full-scale test should include a minimum of two rib-spans with three floorbeams.

Previously verified Level 1 designs that have been verified by laboratory testing may be used as the basis for design on new projects without additional testing, subject to approval by the Owner.

9.8.3.4.3—Level 2 Design

9.8.3.4.3a—General

Details not subjected to local distortional mechanisms similar to those previously proven by appropriate

laboratory testing or those that have been proven effective by Level 3 designs and long term observation while subjected to the appropriate loads may be verified considering only nominal stresses determined from simplified analysis.

9.8.3.4.3b—Decks with Open Ribs

The rib may be analyzed as a continuous beam supported by the floorbeams.

For rib spans not exceeding 15.0 ft, the load on the one rib due to wheel loads may be determined as the reaction of transversely continuous deck plate supported by rigid ribs. For rib spans with greater than 15.0 ft, the effect of rib flexibility on the lateral distribution of wheel loads may be determined by elastic analysis.

For rib spans less than 10.0 ft or for decks with shallow floorbeams, the flexibility of the floorbeams shall be considered in calculating force effects in the ribs.

9.8.3.4.3c—Decks with Closed Ribs

For the global analysis of decks with closed ribs, the semi-empirical Pelikan-Esslinger method may be used. The load effects on a closed rib with a span not greater than 20.0 ft may be calculated from wheel loads placed over one rib only, without regard for the effects of adjacent transversely located wheel loads.

For longer rib spans, appropriate corrections of load effects on ribs shall be calculated.

9.8.3.4.4—Level 3 Design

New orthotropic details may be designed using refined three-dimensional analysis as defined in Article 4.6.3.2.3 and as specified below. For fatigue analysis, the structural modeling techniques shall include:

- Use of shell or solid elements with acceptable formulation to accommodate steep stress gradients,
- Mesh density of $t \times t$, where t is the thickness of the plate component, and
- Local structural stresses shall be determined as specified below

For fatigue design, the local structural stress shall be used for comparison to the nominal fatigue resistance. Local structural stress at welded connections shall be measured perpendicular to the weld toe and is determined using reference points in the finite element model and extrapolation as shown in Figure 9.8.3.4.4-1. The reference points shall be located at the surface of elements at a distance of $0.5 t$ and $1.5 t$ measured perpendicular from the weld toe, respectively, with the local structural stress f_{lss} determined as:

$$f_{lss} = 1.5f_{0.5} - 0.50f_{1.5} \quad (9.8.3.4.4-1)$$

where:

$f_{0.5}$ = the surface stress at a distance of 0.5t from the weld toe (ksi)

$f_{1.5}$ = the surface stress at a distance of 1.5t from the weld toe (ksi)

Design Level 3 shall be required for all bridge redecking applications unless the redecking procedure can be demonstrated as meeting the requirements of Article 9.8.3.4.1 and is approved by the Owner.

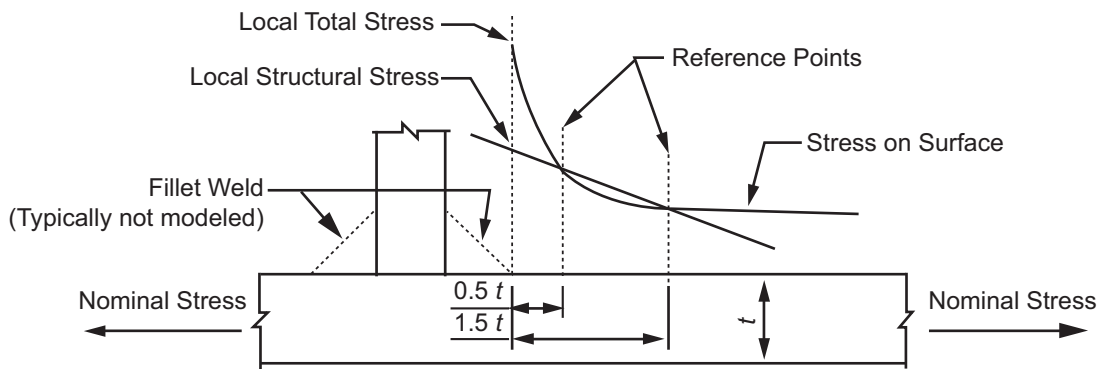

Figure 9.8.3.4.4-1—Local Structural Stress

9.8.3.5—Design

9.8.3.5.1—Superposition of Local and Global Effects

In calculating extreme force effects in the deck, the combination of local and global effects should be determined as specified in Article 6.14.3.

C9.8.3.5.1

The orthotropic deck is part of the global structural system, and, therefore, participates in distributing global stresses. These stresses may be additive to those generated in the deck locally. The axles of the design truck or the design tandem is used for the design of decks, whereas the rest of the bridge is proportioned for combinations of the design truck, the design tandem, and the design lane load. The governing positions of the same load for local and global effects could be quite different. Therefore, the Designer should analyze the bridge for both load regimes separately, apply the appropriate dynamic load allowance factor, and use the one that governs.

9.8.3.5.2—Limit States

9.8.3.5.2a—General

Orthotropic decks shall be designed to meet the requirements of Section 6 at all applicable limit states unless otherwise specified herein.

C9.8.3.5.2a

Tests indicate a large degree of redundancy and load redistribution between first yield and failure of the deck. The large reduction in combined force effects is a reflection of this performance.

9.8.3.5.2b—Service Limit State

At the service limit state, the deck shall satisfy the requirements as specified in Article 2.5.2.6.

9.8.3.5.2c—Strength Limit State

At the strength limit state for the combination of local and global force effects, the provisions of Article 6.14.3 shall apply.

The effects of compressive instability shall be investigated at the strength limit state. If instability does not control, the resistance of orthotropic plate deck shall be based on the attainment of yield strength at any point in the cross-section.

9.8.3.5.2d—Fatigue Limit State

Structural components shall be checked for fatigue in accordance with the appropriate design level as specified in Article 9.8.3.4. The provisions of Article 6.6.1.2 shall apply for load-induced fatigue.

With the Owner's approval, application of less stringent fatigue design rules for interior traffic lanes of multilane decks subjected to infrequent traffic may be considered.

9.8.3.6—Detailing Requirements*9.8.3.6.1—Minimum Plate Thickness*

Minimum plate thickness shall be determined as specified in Article 6.7.3.

C9.8.3.5.2b

Service Limit State I must be satisfied of overall deflection limits and is intended to prevent premature deterioration of the wearing surface.

Service Limit State II is for the design of bolted connections against slip for overload and should be considered for the design of the rib and floorbeam splices. The remaining limit states are for tensile stresses in concrete structures and can be ignored.

C9.8.3.5.2c

The deck, because it acts as part of the global structural system, is exposed to in-plane axial tension or compression. Consequently, buckling should be investigated.

Strength design must consider the following demands: rib flexure and shear, floorbeam flexure and shear, and panel buckling. The rib, including the effective portion of deck plate, must be evaluated for flexural and shear strength for its span between the floorbeams. The floorbeam, including the effective portion of the deck plate, must be evaluated for flexural and shear strength for its span between primary girders or webs. The reduction in floorbeam cross-section due to rib cutouts must be considered. When the panel is part of a primary girder flange, the panel must be evaluated for axial strength based on stability considerations.

Strength Limit IV condition is only expected to control where the orthotropic deck is integral with a long-span bridge superstructure.

C9.8.3.5.2d

Experience has shown that fatigue damage on orthotropic decks occurs mainly at the ribs under the truck wheel paths in the exterior lanes.

For Level 1 design, test loads should be representative of the fatigue truck factored for the Fatigue I load combination and the critical details of the test specimen(s) should simulate both the expected service conditions and the appropriate boundary conditions; verification of these details is sufficient in lieu of a detailed refined fatigue analysis.

9.8.3.6.2—Closed Ribs

The one-sided weld between the web of a closed rib and the deck plate shall have a target penetration of 80 percent, with 70 percent minimum and no blow-through, and shall be placed with a tight fit of less than 0.02 in. gap prior to welding.

C9.8.3.6.2

Historically, the rib-to-deck plate weld has been specified as a one-sided partial penetration weld with minimum 80 percent penetration. Achieving a minimum of 80 percent penetration without blow-through is very difficult and fabricators have often failed to consistently satisfy this requirement. A review of the literature suggests that it is the maximum penetration that could be achieved without regularly resulting in weld blow-through. It has been suggested that the weld throat should, at a minimum, be of the same size as the rib wall and that the penetration be between 50 and 80 percent (Kolstein, 2007). However, a lower penetration limit of only 50 percent results in a rather large lack of fusion plane and increases the risk of cracks initiating from the root. Levels between 75 and 95 percent, with a target of 80 percent, are achievable and the lower bound of 70 percent is supported by research (Xiao, 2008).

The root gap is also a parameter that may influence performance. Research has shown that fatigue resistance of the weld is clearly improved when the root gap is closed in the final condition. When there is full contact, it appears that the root is protected and cracking is prevented. Shop experience indicates that using a tight fit prior to welding will also help prevent weld blow-through. Kolstein (2007) suggests the limit of 0.02 in. and this is adopted in these Specifications.

Additionally, melt-through of the weld is a quality issue that must be controlled. Fatigue tests on a limited number of samples (Sim and Uang, 2007) indicate that the performance of locations of melt-through is greater than or equal to those created by the notch condition of the 80 percent penetration. However, there are legitimate concerns that excessive melt-through may provide potential fatigue initiation sites and as such it should be avoided if possible. As such, the proposed detailing criteria is that the rib to deck shall be one-sided nominal 80 percent penetration, with 70 percent minimum and no blow-through, and with a tight fit less than 0.02 in. prior to welding. Additional details of the weld joint should be left for the fabricator to develop.

9.8.3.6.3—Welding to Orthotropic Decks

Welding of attachments, utility supports, lifting lugs, or shear connectors to the deck plate or ribs shall require approval by an Engineer.

9.8.3.6.4—Deck and Rib Details

Deck and rib splices shall either be welded or mechanically fastened by high-strength bolts. Ribs shall be run continuously through cutouts in the webs of floorbeams, as shown in Figure 9.8.3.6.4-1. The following fabrication details shall be required by the contract documents as identified in Figure 9.8.3.6.4-1:

C9.8.3.6.4

Closed ribs may be trapezoidal, U-shaped, or V-shaped; the latter two are most efficient.

The floorbeam web cutouts at the intersections with the ribs may be with or without an additional free cutout at the bottom of the ribs. The former detail is generally preferable since it minimizes the rib restraint against

- a) No snipes (cutouts) in floorbeam web
- b) Welds to be wrapped around
- c) Grind smooth
- d) Combined fillet-groove welds may have to be used 1) in cases where the required size of fillet welds to satisfy the fatigue resistance requirements would be excessive if used alone or 2) to accomplish a ground termination.

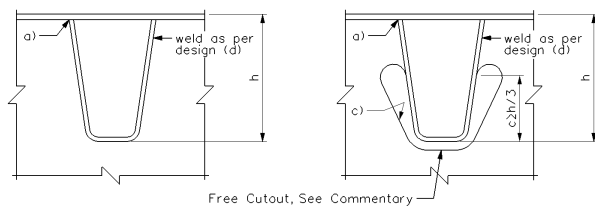

a) Intersections of closed ribs with floorbeams.

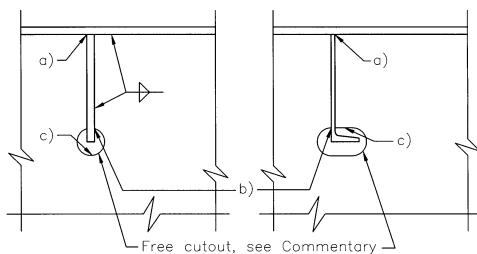

b) Intersections of open ribs with floorbeams.

Figure 9.8.3.6.4-1—Detailing Requirements for Orthotropic Decks

rotation in its plane and associated stresses in the welds and in the floorbeam web.

If the bottom cutout depth c is small enough, the rotation of the rib is restrained and considerable out-of-plane stresses are introduced in the floorbeam web when the floorbeam is shallow. Local secondary stresses are also introduced in the rib walls by the interaction forces between the floorbeam webs and the rib walls and by secondary effects due to the small depth of cutout c (Wolchuk and Ostapenko, 1992).

If the floorbeam web is deep and flexible, or where additional depth of the cutout would unduly reduce the shear strength of the floorbeam, welding all around the rib periphery may be appropriate (*ECSC Report on Fatigue*, 1995, Wolchuk, 1999).

Fatigue test suggested that open snipes in the floorbeam webs at the junctions of the rib walls with the deck plate may cause cracks in the rib walls. Therefore, a tight-fitting snipe and a continuous weld between the floorbeam web and the deck and rib wall plates appear to be preferable.

Open ribs may be flat bars, angles, tees or bulb bars. Open-rib decks are less efficient and require more welding but are generally considered less risky to fabricate.

[This page is intentionally left blank. —ed.]

[This page is intentionally left blank. —ed.]

9.8.4—Orthotropic Aluminum Decks

9.8.4.1—General

Orthotropic aluminum decks shall consist of a deck plate stiffened and supported by rib extrusions. The ribs may be parallel or perpendicular to the direction of traffic.

The provisions of Article 9.8.3.2 through Article 9.8.3.3 shall apply, except that the wearing surface shall not be regarded as an integral part of the orthotropic deck for analysis and design of the deck or rib.

When an aluminum orthotropic deck is supported by components of another material, the differences in thermal expansion of the two materials and the potential for accelerated corrosion due to dissimilar metals shall be considered.

The structural interaction of an aluminum orthotropic deck with the existing structure shall be investigated.

9.8.4.2—Approximate Analysis

In lieu of more precise information, the effective width of deck plate acting with a rib shall not exceed the rib spacing or one-third of the span.

The flexibility of the supports shall be considered in determining the longitudinal moments in continuous decks.

In determining the transverse moments, the effects of the torsional rigidity of the ribs shall be included when the ribs are torsionally stiff and may be disregarded if the ribs are torsionally flexible.

For the analysis of decks with closed ribs, the provisions of Article 9.8.3.4.3c may be applied.

9.8.4.3—Limit States

Orthotropic decks shall be designed to meet the requirements of Section 7 at all applicable limit states.

At the service limit state, the deck shall satisfy the requirement of Article 2.5.2.6.

The longitudinal ribs, including an effective width of deck plate, shall be investigated for stability as individual beam-columns assumed as simply supported at transverse beams.

At the fatigue limit state, the deck shall satisfy the provisions of Article 7.6.

Regardless of whether the stress range is tensile, compressive, or reversal, maximum stress range shall be investigated for:

- Transverse direction at the rib-to-plate connection;
- Longitudinal direction;
- All bolted, welded end, and edge details; and
- Transverse direction at the rib-to-plate connection when the adjacent rib is loaded.

C9.8.4.1

Only one application of ribs placed perpendicular to traffic was known as of 1997. Therefore, little or no experience of in-service fatigue behavior exists, and complete investigation of load-induced and distortion-induced fatigue should be required for this application.

C9.8.4.2

The transverse moments should be calculated in two stages: those due to the direct loading of the deck plate, assuming nondeflecting ribs, and those due to the transverse shear transfer resulting from the rib displacements. Stresses from these moments are then combined.

C9.8.4.3

This condition has been shown to control the design under certain geometrical conditions.

The maximum stress range is used for design because significant tensile residual stresses exist adjacent to most weldments, and gross compressive stresses may result in a net tensile stress range.

See Menzemer et al. (1987) for additional discussion.

9.8.5—Corrugated Metal Decks

9.8.5.1—General

Corrugated metal decks should be used only on secondary and rural roads.

Corrugated metal decks shall consist of corrugated metal pans filled with bituminous asphalt or another approved surfacing material. The metal pans shall be positively fastened to the supporting components.

9.8.5.2—Distribution of Wheel Loads

A 45-degree distribution of the tire load from the contact area to the neutral axis of the corrugated metal pans may be assumed.

9.8.5.3—Composite Action

For contribution of the fill to composite action with the deck plate, the provisions of Article 9.8.3.3 shall apply.

Composite action of the corrugated metal deck pan with the supporting components may be considered only if the interface connections are designed for full composite action, and the deck is shown to resist the compressive forces associated with the composite action.

9.9—WOOD DECKS AND DECK SYSTEMS

9.9.1—Scope

This Article shall apply to the design of wood decks supported by beams, stringers, or floorbeams or used as a deck system.

9.9.2—General

The provisions of Section 8 shall apply.

Materials used in wood decks and their preservative treatment shall meet the requirements of Sections 2, 5, 6, and 8.

The nominal thickness of plank decks shall not be less than 4.0 in. for roadways and 2.0 in. for sidewalks. The nominal thickness of wood decks other than plank decks shall not be less than 6.0 in.

9.9.3—Design Requirements

9.9.3.1—Load Distribution

Force effects may be determined by using one of the following methods:

C9.8.5.1

The intent of fastening the corrugated metal pans to the supporting components is to ensure the stability of both under transient loads.

C9.8.5.2

The 45-degree distribution is a traditional approach for most nonmetallic structural materials.

C9.8.5.3

Due to the sensitivity of the plate to temperature, corrosion, and structural instability, composite action should be utilized only if physical evidence is sufficient to prove that its functionality can be counted on for the specified design life.

C9.9.1

This Article applies to wood decks and deck systems that are currently being designed and built in the United States and that have demonstrated acceptable performance. The supporting components may be metal, concrete, or wood.

C9.9.2

In laminated decks, large deviations in the thickness or extensive warping of the laminations may be detrimental regarding both strength and long-term performance. Although rough or full sawn material can be more economical than planed, the variations in dimensions can be quite large. If appropriate dimensional tolerances are not likely to be obtained, dressing of the components should be recommended.

C9.9.3.1

- The approximate method specified in Article 4.6.2.1,
- Orthotropic plate theory, or
- Equivalent grillage model.

If the spacing of the supporting components is less than either 36.0 in. or 6.0 times the nominal depth of the deck, the deck system, including the supporting components, shall be modeled as an orthotropic plate or an equivalent grid.

In stress laminated decks, satisfying the butt stagger requirements specified in Article 9.9.5.3, rigidity may be determined without deduction for the butt joints.

9.9.3.2—Shear Design

Shear effects may be neglected in the design of stress laminated decks.

In longitudinal decks, maximum shear shall be computed in accordance with the provisions of Article 8.7.

In transverse decks, maximum shear shall be computed at a distance from the support equal to the depth of the deck.

For both longitudinal and transverse decks, the tire footprint shall be located adjacent to, and on the span side of, the point of the span where maximum force effect is sought.

9.9.3.3—Deformation

At the service limit state, wood decks shall satisfy the requirements as specified in Article 2.5.2.6.

9.9.3.4—Thermal Expansion

The coefficient of thermal expansion of wood parallel to its fibers shall be taken as 0.000002 per °F.

Thermal effects may be neglected in plank decks and spike laminated decks.

For stress laminated and glued laminated panel decks made continuous over more than 400 ft, relative movements due to thermal expansion with respect to substructures and abutments shall be investigated.

9.9.3.5—Wearing Surfaces

Wood decks shall be provided with a wearing surface conforming to the provisions of Article 9.9.8.

9.9.3.6—Skewed Decks

Where the skew of the deck is less than 25 degrees, transverse laminations may be placed on the skew angle. Otherwise, the transverse laminations shall be placed normal to the supporting components, and the free ends of the laminations at the ends of the deck shall be supported by a diagonal beam or other suitable means.

In wood decks with closely spaced supporting components, the assumption of infinitely rigid supports upon which approximate methods of analysis are based, is not valid. Two-dimensional methods of analysis are, therefore, recommended to obtain force effects with reasonable accuracy.

C9.9.3.2

Shear problems in laminated wood decks are rare, as the inherent load sharing benefits of the multiple member system are believed to be quite significant. The probability of simultaneous occurrence of potentially weak shear zones in adjacent laminates is low. Therefore, a multiple member shear failure, which would be necessary to propagate shear splits in any one lamination, would be difficult to achieve.

With little test data available, no changes to the shear design for spike laminated decks is being introduced.

C9.9.3.4

Generally, thermal expansion has not presented problems in wood deck systems. Except for the stress laminated deck and tightly placed glued laminated panels, most wood decks inherently contain gaps at the butt joints that can absorb thermal movements.

C9.9.3.5

Experience has shown that unprotected wood deck surfaces are vulnerable to wear and abrasion and/or may become slippery when wet.

C9.9.3.6

With transverse decks, placement of the laminations on the skew is the easiest and most practical method for small skew angles, and cutting the ends of the laminations on the skew provides a continuous straight edge.

In longitudinal decks, except for stress laminated wood, any skew angle can generally be accommodated by offsetting each adjacent lamination on the skew.

9.9.4—Glued Laminated Decks

9.9.4.1—General

Glued laminated timber panel decks shall consist of a series of panels, prefabricated with water-resistant adhesives, that are tightly abutted along their edges.

Transverse deck panels shall be continuous across the bridge width.

If the span in the primary direction exceeds 8.0 ft, the panels shall be interconnected with stiffener beams as specified in Article 9.9.4.3.

9.9.4.2—Deck Tie-Downs

Where panels are attached to wood supports, the tie-downs shall consist of metal brackets that are bolted through the deck and attached to the sides of the supporting component. Lag screws or deformed shank spikes may be used to tie panels down to wood support.

Where panels are attached to steel beams, they shall be tied down with metal clips that extend over the beam flange and that are bolted through the deck.

9.9.4.3—Interconnected Decks

9.9.4.3.1—Panels Parallel to Traffic

Interconnection of panels shall be made with transverse stiffener beams attached to the underside of the deck. The distance between stiffener beams shall not exceed 8.0 ft, and the rigidity, EI , of each stiffener beam shall not be less than 80,000 kip-in.². The beams shall be attached to each deck panel near the panel edges and at intervals not exceeding 15.0 in.

9.9.4.3.2—Panels Perpendicular to Traffic

Interconnection of panels may be made with mechanical fasteners, splines, dowels, or stiffener beams. Where used, the stiffener beams should be continuous over the full length of the span and should be secured through the deck within 6.0 in. of the edges of each panel and as required between edges.

When panels are interconnected with stiffener beams, the beams shall be placed longitudinally along the centerspan of each deck span. Provisions of Article 9.9.4.3.1 shall apply for the design of the stiffener beams.

The live load bending moment per unit width shall be determined in accordance with the provisions of Article 4.6.2.1.3.

C9.9.4.1

In glued laminated decks built to date, transverse deck panels have been 3.0 to 6.0 ft wide, and longitudinal deck panels have been 3.5 to 4.5 ft wide. The design provisions are considered applicable only to the range of panel sizes given herein.

These design provisions are based upon development work carried out at the USDA Forest Products Laboratory in the late 1970s.

This form of deck is appropriate only for roads having low to medium volumes of commercial vehicles.

C9.9.4.2

The methods of tie-down specified herein are based upon current practices that have proven to be adequate. Use of other methods require approval by Owner.

C9.9.4.3.1

Although the transverse stiffener beam ensures interpanel shear transfer of loads, some relative deflection will take place. Under frequent heavy loads, this relative deflection will cause reflective cracking of bituminous wearing surfaces.

C9.9.4.3.2

The doweling of the deck system is intended to prevent relative displacement of the glued laminated deck panels. A design procedure for dowels can be found in Ritter (1990). With proper prefabrication and construction, this doweled system has proven to be effective in preventing relative displacement between panels. However, in practice, problems with hole alignment and the necessity for field modifications may reduce their efficiency.

Using one longitudinal stiffener beam in each space between girders has proven to be both a practical and effective method of reducing relative displacements between transverse panels.

9.9.4.4—Noninterconnected Decks

Decks not interconnected at their edges shall only be employed on secondary, rural roads. No transfer of force effects at the panel edges shall be assumed in the analysis.

9.9.5—Stress Laminated Decks

9.9.5.1—General

Stress laminated decks shall consist of a series of wood laminations that are placed edgewise and post-tensioned together, normal to the direction of the lamination.

Stress laminated decks shall not be used where the skew exceeds 45 degrees.

The contract documents shall require that the material be subjected to expansion baths to remove excess oils.

9.9.5.2—Nailing

Each lamination shall be specified to be fastened to the preceding one by common or spiral nails at intervals not exceeding 4.0 ft. The nails shall be driven alternately near the top and bottom edges of the laminations. One nail shall be located near both the top and bottom at butt joints. The nails should be of sufficient length to pass through two laminations.

C9.9.4.4

The noninterconnected panel deck will likely cause reflective cracking in the wearing surface at the butt joints, even under relatively low levels of loading. It is appropriate only for roads having low volumes of commercial vehicles in order to avoid the extensive maintenance that the wearing surface may require.

C9.9.5.1

The majority of decks of this type include laminations which are 2.0 to 3.0 in. in thickness.

The increased load distribution and load sharing qualities of this deck, coupled with its improved durability under the effects of repeated heavy vehicles, make it the best choice among the several wood decks for high volume road application (Csagoly and Taylor, 1979; Sexsmith et al., 1979).

The structural performance of these decks relies on friction, due to transverse prestress, between the surfaces of the laminations to transfer force effects. Unlike spiked or bolted connections in wood, the friction-based performance of stress laminated decks does not deteriorate with time under the action of repeated heavy loads.

Experience seems to indicate that the use of waterborne preservatives can negatively affect the performance of stress laminated decks. Wood treated with waterborne preservatives responds rapidly to the short-term changes in moisture conditions to which bridges are subjected frequently in most areas of North America. The attendant dimensional changes in the wood can result in substantial changes in the prestressing forces. Wood treated with oil-borne preservatives does not respond so readily to short-term changes in moisture conditions.

The preservative treatment for wood to be used in stress laminated decks should be kept to the minimum specified in the standards given in Article 8.4.3. Excessive oils in the wood may be expelled after the deck is stressed and can contribute to higher prestress losses over a short period after construction.

C9.9.5.2

Nailing is only a temporary construction convenience in stress laminated decks, and it should be kept as close to minimum requirements as possible. Excessive nailing may inhibit the build up of elastic strains during transverse stressing, which could subsequently contribute to decreasing its effectiveness.

9.9.5.3—Staggered Butt Joints

Where butt joints are used, not more than one butt joint shall occur in any four adjacent laminations within a 4.0 ft distance, as shown in Figure 9.9.5.3-1.

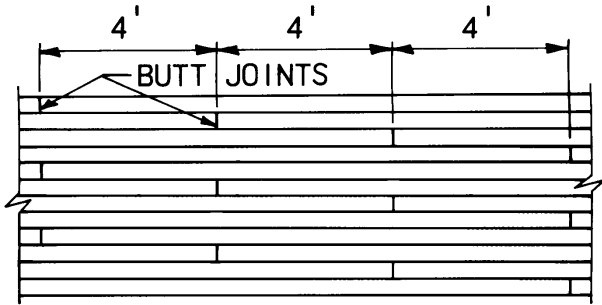

Figure 9.9.5.3-1—Minimum Spacing of Lines of Butt Joints

9.9.5.4—Holes in Laminations

The diameter of holes in laminations for the prestressing unit shall not be greater than 20 percent of the lamination depth. Spacing of the holes along the laminations shall be neither less than 15.0 times the hole diameter nor less than 2.5 times the depth of the laminate.

Only drilled holes shall be permitted.

9.9.5.5—Deck Tie-Downs

Decks shall be tied down at every support, and the spacing of the tie-downs along each support shall not exceed 3.0 ft. Each tie-down shall consist of a minimum of two 0.75-in. diameter bolts for decks up to and including 12.0 in. deep and two 1.0-in. diameter bolts for decks more than 12.0 in. deep.

9.9.5.6—Stressing

9.9.5.6.1—Prestressing System

New stressed wood decks shall be designed using internal prestressing. External prestressing may be used to rehabilitate existing nail laminated decks and shall utilize continuous steel bulkheads.

In stress laminated decks, with skew angles less than 25 degrees, stressing bars may be parallel to the skew. For skew angles between 25 degrees and 45 degrees, the bars should be placed perpendicular to the laminations, and in the end zones, the transverse prestressing bars should be fanned in plan as shown in Figure 9.9.5.6.1-1 or arranged in a step pattern as shown in Figure 9.9.5.6.1-2.

Dimensional changes in the deck due to prestressing shall be considered in the design.

Anchorage hardware for the prestressing rods should be arranged in one of the three ways shown in Figure 9.9.5.6.1-3.

C9.9.5.3

Butt joint requirements are extreme values and are intended to allow for lamination lengths that are less than the deck length. Uniformly reducing or eliminating the occurrence of butt joints and/or distributing butt joints will improve performance.

The implication of this provision is that laminations shorter than 16.0 ft cannot be used. If laminations longer than 16.0 ft are used, the spacing of butt joint is one-quarter of the length.

C9.9.5.4

These empirical limitations are intended to minimize the negative effects of hole size and spacing on the performance of the deck.

Punched holes can seriously affect the performance of the laminates by breaking the wood fibers in the vicinity of the holes.

C9.9.5.5

The stress laminated deck requires a more effective tie-down than toe-nailing or drift pins. It has a tendency to develop curvature perpendicular to the laminates when transversely stressed. Tie-downs using bolts or lag screws ensure proper contact of the deck with the supporting members.

C9.9.5.6.1

External and internal prestressing systems are shown in Figure 9.9.5.6.1-3. The internal system provides better protection to the prestressing element and lessens restriction to the application of wearing surfaces.

Generally, it is not necessary to secure timber decks to the supports until all the transverse stressing has been completed. There is the potential for extensive deformation when a deck is stressed over a very long length due to unintentional eccentricity of prestressing. It is recommended that restraints during stressing be provided when the width of the deck, perpendicular to the laminations, exceeds 50.0 times the depth of the deck for longitudinal decks and 40.0 times the depth of the deck for transverse decks. These restraints should not inhibit the lateral movement of the deck over its width during the stressing procedure.

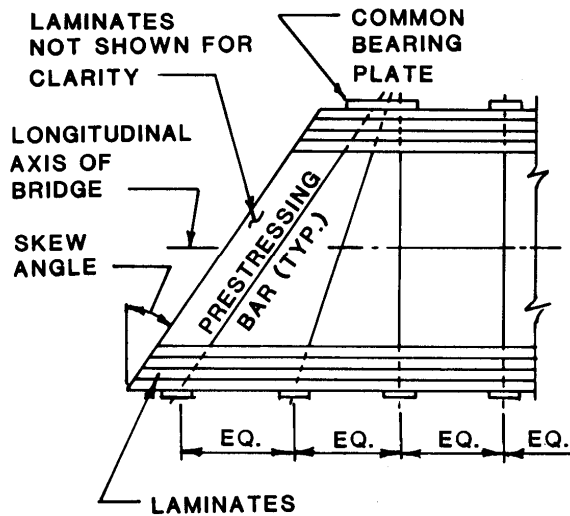

Potential concentration of bearing stresses and sliding of the common bearing plate should be considered in conjunction with the fanned arrangement of prestressing elements shown in Figure 9.9.5.6.1-1.

Figure 9.9.5.6.1-1—Fanned Layout of Prestressing Bars in End Zones of Skewed Decks—Illustrative Only

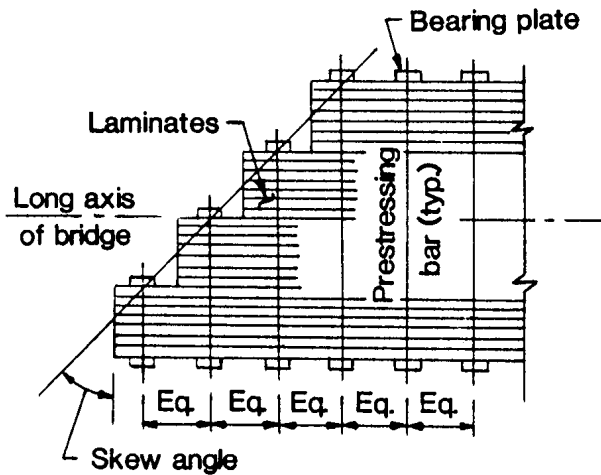
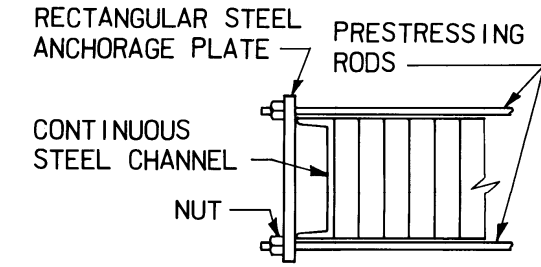
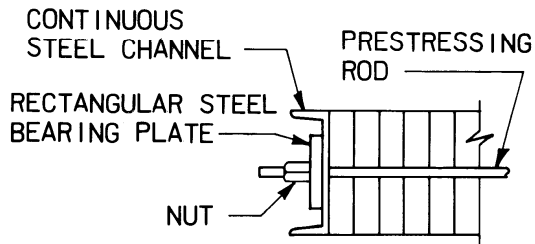

Figure 9.9.5.6.1-2—Staggered Layout of Prestressing Bars in End Zone of Skewed Decks—Illustrative Only



A. EXTERNAL CHANNEL BULKHEAD ANCHORAGE CONFIGURATION.



B. CHANNEL BULKHEAD ANCHORAGE CONFIGURATION.

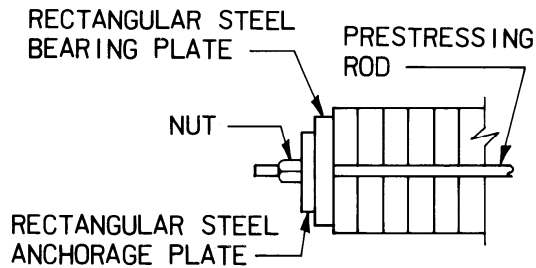

C. BEARING PLATE ANCHORAGE CONFIGURATION.

Figure 9.9.5.6.1-3—Types of Prestressing Configurations

The isolated steel bearing plates should be used only on hardwood decks, or, where a minimum of two hardwood laminations are provided, on the outside edges of the deck.

Continuous steel bulkheads or hardwood laminations are required because they improve field performance. Isolated steel bearing plates on softwood decks have caused crushing of the wood, substantially increased stress losses and resulted in poor aesthetics.

9.9.5.6.2—Prestressing Materials

C9.9.5.6.2

Prestressing materials shall comply with the provisions of Article 5.4.

All prestressed wood decks built to date have utilized high-strength bars as the stressing elements. Theoretically, any prestressing system that can be adequately protected against corrosion is acceptable.

9.9.5.6.3—Design Requirements

The steel-wood ratio, R_{sw} , shall satisfy:

$$R_{sw} = \frac{A_s}{sh} \leq 0.0016 \quad (9.9.5.6.3-1)$$

where:

s = spacing of the prestressing elements (in.)

h = depth of deck (in.)

A_s = area of steel bar or strand (in.²)

The prestressing force per prestressing element (kip) shall be determined as:

$$P_{pt} = 0.1hs \quad (9.9.5.6.3-2)$$

The effective bearing area, A_B , on the wood directly under the anchorage bulkhead due to prestress shall be determined by considering the relative stiffness of the wood deck and the steel bulkhead. The bulkhead shall satisfy:

$$P_{BU} = \phi F A_B \geq P_{pt} \quad (9.9.5.6.3-3)$$

where:

P_{BU} = factored compressive resistance of the wood under the bulkhead (kip)

ϕ = resistance factor for compression perpendicular to grain as specified in Article 8.5.2.2

F = as specified in Table 9.9.5.6.3-1

C9.9.5.6.3

The limitation on the steel-wood area ratio is intended to decrease prestress losses due to relaxation caused by wood and steel creep as well as deck dimensional changes due to variations in wood moisture content. Prestress losses are very sensitive to this ratio, and most existing structures have values less than 0.0016. A small area ratio of 0.0012 to 0.0014, coupled with an initial moisture content of less than 19 percent and proper preservative treatment, will ensure the highest long-term prestress levels in the deck.

The average compressive design stress represents the uniform pressure that is achieved away from the anchorage bulkhead. Limitation on compressive stress at maximum prestress minimizes permanent deformation in the wood. Increasing the initial compressive stress beyond these levels does not significantly increase the final compressive stress after all losses have occurred.

Eq. 9.9.5.6.3-2 is based on a uniform compressive stress of 0.1 ksi between the laminations due to prestressing. For structural analysis, a net compressive stress of 0.04 ksi, after losses, may be assumed.

Relaxation of the prestressing system is time-dependent, and the extensive research work, along with the experience obtained on the numerous field structures, have shown that it is necessary to restress the system after the initial stressing to offset long-term relaxation effects. The optimum stressing sequence is as follows:

- Stress to full design level at time of construction,
- Restress to full design level not less than one week after the initial stressing, and
- Restress to full design level not less than four weeks after the second stressing.

After the first restressing, increasing the time period to the second restressing improves long-term stress retention. Subsequent restressings will further decrease the effects of long-term creep losses and improve stress retention.

Table 9.9.5.6.3-1— F Values for Prestressed Wood Decks

Species	F (ksi)
Douglas Fir Larch	0.425
Hemlock Fir	0.275
Spruce-Pine Fir	0.275
Eastern Softwoods	0.225
Mixed Southern Pine	0.375
Southern Pine	0.375
Spruce-Pine Fir-South	0.225
Northern Red Oak	0.600
Red Maple	0.400
Red Oak	0.550
Yellow Poplar	0.275

9.9.5.6.4—Corrosion Protection

Elements of the prestressing system shall be protected by encapsulation and/or surface coatings. The protective tubing shall be capable of adjusting at least ten percent of its length during stressing without damage.

C9.9.5.6.4

Elements of a suitable protection system are shown in Figure C9.9.5.6.4-1.

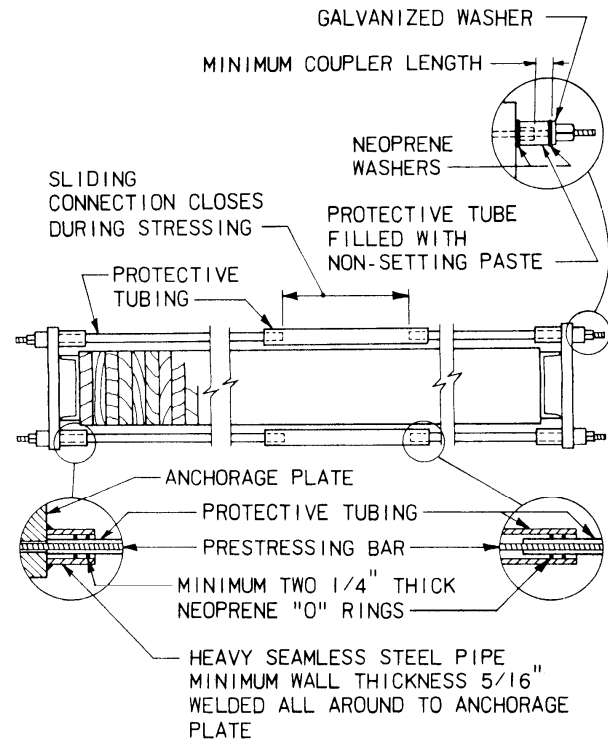

Figure C9.9.5.6.4-1—Elements of Corrosion Protection

9.9.5.6.5—Railings

Railings shall not be attached directly either to any prestressing element or to bulkhead systems. The deck shall not be penetrated within 6.0 in. of a prestressing element.

C9.9.5.6.5

Curb and rail attachment directly to any component of the stressing system increases the risk of failure in the event of vehicle impact.

9.9.6—Spike Laminated Decks

9.9.6.1—General

Spike laminated decks shall consist of a series of lumber laminations that are placed edgewise between supports and spiked together on their wide face with deformed spikes of sufficient length to fully penetrate four laminations. The spikes shall be placed in lead holes that are bored through pairs of laminations at each end and at intervals not greater than 12.0 in. in an alternating pattern near the top and bottom of the laminations, as shown in Figure 9.9.6.1-1.

Laminations shall not be butt spliced within their unsupported length.

C9.9.6.1

The use of spike laminated decks should be limited to secondary roads with low truck volumes, i.e., *ADTT* significantly less than 100 trucks per day.

The majority of decks of this type have used laminations of 3.0 to 4.0 in. in thickness. The laminates are either assembled on site or are prefabricated into panels in preparation for such assembly.

The specified design details for lamination arrangement and spiking are based upon current practice. It is important that the spike lead holes provide a tight fit to ensure proper load transfer between laminations and to minimize mechanical movements.

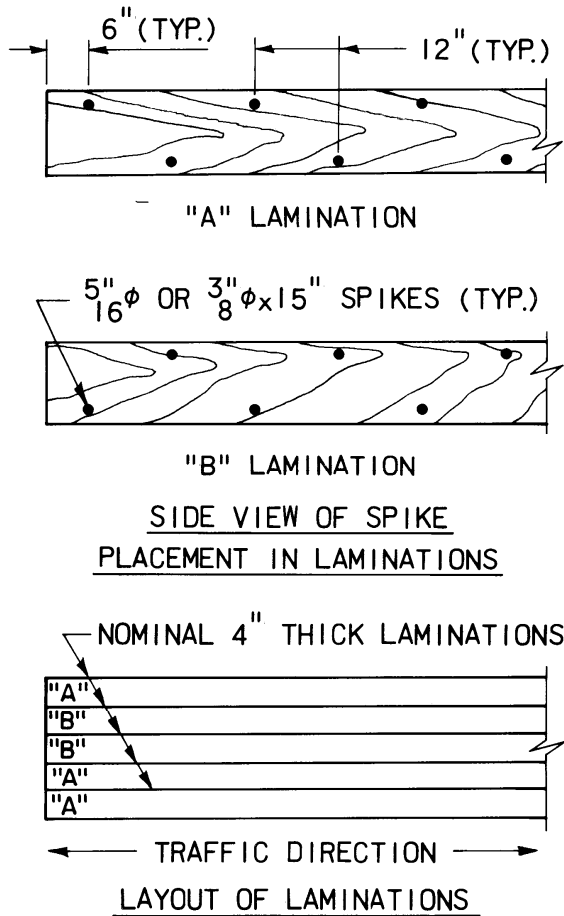

Figure 9.9.6.1-1—Spike Layout for Spike Laminated Decks

9.9.6.2—Deck Tie-Downs

Deck tie-downs shall be as specified in Article 9.9.4.2.

9.9.6.3—Panel Decks

The distribution widths for interconnected spike laminated panels may be assumed to be the same as those for continuous decks, as specified in Section 4.

The panels may be interconnected with mechanical fasteners, splines, dowels, or stiffener beams to transfer shear between the panels. If stiffener beams are used, the provisions of Article 9.9.4.3 shall apply.

C9.9.6.3

The use of noninterconnected decks should be limited to secondary and rural roads.

It is important to provide an effective interconnection between panels to ensure proper load transfer. Stiffener beams, comparable to those specified for glued laminated timber panels, are recommended. Use of an adequate stiffener beam enables the spike laminated deck to approach the serviceability of glue laminated panel construction.

With time, the deck may begin to delaminate in the vicinity of the edge-to-edge panel joints. The load distribution provisions given for the noninterconnected panels are intended for use in the evaluation of existing noninterconnected panel decks and interconnected panel decks in which the interconnection is no longer effective.

9.9.7—Plank Decks

9.9.7.1—General

Wood plank decks shall consist of a series of lumber planks placed flatwise on supports. Butt joints shall be placed over supports and shall be staggered a minimum of 3.0 ft for adjacent planks.

9.9.7.2—Deck Tie-Downs

On wood beams, each plank shall be nailed to each support with two nails of minimum length equal to twice the plank thickness.

On steel beams, planks shall be bolted to the beams or nailed to wood nailing strips. The strips should be at least 4.0 in. thick, and their width should exceed that of the beam flange. The strips should be secured with A 307 bolts at least 0.625 in. in diameter and placed through the flanges, spaced not more than 4.0 ft apart and no more than 1.5 ft from the ends of the strips.

9.9.8—Wearing Surfaces for Wood Decks

9.9.8.1—General

Wearing surfaces shall be of continuous nature and no nails, except in wood planks, shall be used to fasten them to the deck.

9.9.8.2—Plant Mix Asphalt

An approved tack coat shall be applied to wood decks prior to the application of an asphalt wearing surface. The tack coat may be omitted when a geotextile fabric is used, subject to the recommendations of the manufacturer.

When possible, a positive connection between the wood deck and the wearing surface shall be provided. This connection may be provided mechanically or with a geotextile fabric.

The asphalt should have a minimum compacted depth of 2.0 in. Where cross slope is not provided by the wood deck, a minimum of one percent shall be provided by the wearing surface.

C9.9.7.1

This type of deck has been used on low volume roads with little or no heavy vehicles, and it is usually economical. However, these decks provide no protection against moisture to the supporting members; they will not readily accept and/or retain a bituminous wearing surface and usually require continuous maintenance if used by heavy vehicles.

These decks should be limited to roads that carry little or no heavy vehicles or where the running surface is constantly monitored and maintained.

C9.9.8.1

Bituminous wearing surfaces are recommended for wood decks.

The surface of wood deck should be free of surface oils to encourage adhesion and prevent bleeding of the preservative treatment through the wearing surface. Excessive bleeding of the treatment can seriously reduce the adhesion. The plans and specifications should clearly state that the deck material be treated using the empty cell process, followed by an expansion bath or steaming.

C9.9.8.2

The application of a tack coat greatly improves the adhesion of asphalt wearing surfaces.

Due to the smooth surface of individual laminations and glued laminated decks, it is beneficial to provide a positive connection in order to ensure proper performance. The use of asphalt impregnated geotextile fabric, when installed properly, has proven to be effective.

Asphalt wearing surfaces on stress laminated wood decks have proven to perform well with only a tack coat and no reinforcement between the deck and the asphalt.

9.9.8.3—Chip Seal

When a chip seal wearing surface is used on wood decks, a minimum of two layers should be provided.

C9.9.8.3

Laminated decks may have offset laminations creating irregularities on the surface, and it is necessary to provide an adequate depth of wearing surface to provide proper protection to the wood deck. Chip seal wearing surfaces have a good record as applied to stress laminated decks due to their behavior approaching that of solid slabs.

9.10—REFERENCES

Ahlskog, J. 2000. "Vibration and Deflection Criteria for Lightweight Decks Designed Using the LRFD Code." Being submitted for publication.

AISC. 1963. *Design Manual for Orthotropic Steel Plate Deck Bridges*. American Institute of Steel Construction, Chicago, IL.

Baker, T. H. 1991. *Volume I, Plate Stiffness Constants for Concrete Filled Steel Grid Decks, Static and Fatigue Strength Determination of Design Properties for Grid Bridge Decks*, Research Report ST-9, Department of Civil Engineering, University of Pittsburgh, Pittsburgh, PA.

Bieschke, L. A., and R. E. Klingner. 1982. *The Effect of Transverse Strand Extensions on the Behavior of Precast Prestressed Panel Bridges*, FHWA/TX-82/18-303-1F. Federal Highway Administration, Washington, DC, University of Texas, Austin, TX.

Buth, E., H. L. Furr, and H. L. Jones. 1992. *Evaluation of a Prestressed Panel, Cast-in-Place Bridge*, TTI-2-5-70-145-3. Texas Transportation Institute, College Station, TX.

Connor, R. J. 2002. "A Comparison of the In-service Response of an Orthotropic Steel Deck with Laboratory Studies and Design Assumptions." Ph.D. dissertation, Department of Civil Engineering, Lehigh University, Bethlehem, PA, May 2002.

Connor, R. J. and J. W. Fisher. 2004. *Results of Field Measurements Made on the Prototype Orthotropic Deck on the Bronx-Whitestone Bridge—Final Report*, ATLSS Report No. 04-03. Center for Advanced Technology for Large Structural Systems, Lehigh University, Bethlehem PA.

Connor, R. J., and J. W. Fisher. 2006. "Consistent Approach to Calculating Stresses for Fatigue Design of Welded Rib-to-Web Connections in Steel Orthotropic Bridge Decks," *Journal of Bridge Engineering*. American Society of Civil Engineers, Reston, VA, Vol. 11, No. 5, September/October 2006, pp. 517–525.

Csagoly, P. F. 1979. *Design of Thin Concrete Deck Slabs by the Ontario Highway Bridge Design Code*. Ministry of Transportation of Ontario, Downsview, Ontario, Canada.

Csagoly, P. F., and J. M. Lybas. 1989. "Advanced Design Method for Concrete Bridge Deck Slabs," *Concrete International*. American Concrete Institute, Farmington Hills, MI, Vol. 11, No. 5, May 1989, pp. 53–64.

Csagoly, P. F., and W. N. Nickas. 1987. "Florida Bulb-Tee and Double-Tee Beams," *Concrete International*. American Concrete Institute, Farmington Hills, MI, Vol. 9, No. 11, November 1987, pp. 18–23.

Csagoly, P. F., and R. J. Taylor. 1979. *A Development Program for Wood Highway Bridges*. Ministry of Transportation of Ontario, Downsview, Ontario, Canada.

CEN (European Committee for Standardization). 1992. *Eurocode 3 Design of Steel Structures*. European Committee for Standardization, Brussels, Belgium, Section 9, Fatigue.

Connor, R. J. and J. W. Fisher. 2004. *Results of Field Measurements Made on the Prototype Orthotropic Deck on the Bronx-Whitestone Bridge—Final Report*, ATLSS Report No. 04-03. Center for Advanced Technology for Large Structural Systems, Lehigh University, Bethlehem PA.

Daniels, J., and R. Slutter. 1985. *Behavior of Modular Unfilled Composite Steel Grid Bridge Deck Panels*, Report No. 200.84.795.1, Lehigh University, Bethlehem, PA, January 1985.

Darlow, M., and N. Bettigole. 1989. "Instrumentation and Testing of Bridge Rehabilitated with Exodermic Deck," *Journal of Structural Engineering*. American Society of Civil Engineers, New York, NY, Vol. 115, No. 10, October 1989, pp. 2461–2480.

deV Batchelor, B., K. V. Dalen, T. Morrison, and R. J. Taylor. 1981. *Structural Characteristics of Red-Pine and Hem-Fir in Prestressed Laminated Wood Bridge Decks*. Queens University, Ontario, Canada.

deV Batchelor, B., B. E. Hewitt, and P. F. Csagoly. 1978. "Investigation of the Fatigue Strength of Deck Slabs of Composite Steel/Concrete Bridges." In *Transportation Research Record 664*. Transportation Research Board, National Research Council, Washington, DC.

Dexter, R. T., J. E. Tarquinio, and J. W. Fisher. 1994. Application of Hot Spot Stress Fatigue Analysis to Attachments on Flexible Plate. In *Proc., 13th International Conference on Offshore Mechanics and Arctic Engineering*, ASME, Vol. III, Material Engineering, pp. 85–92.

DiCesare, A., and J. Pensiero. 1992. *Bridge Analysis Report: High Street Bridge over Metro-North Railroad, Dobbs Ferry*. BIN 2265160, M.G. McLaren, P.C., West Nyack, NY, July 1992.

ECSC. 1995. "Measurements and Interpretations of Dynamic Loads and Bridges." In *Phase 4: Fatigue Strength of Steel Bridges*. Common Synthesis Report, edited by A. Bruls. Brussels, Belgium, September 1995, Annex F.

Fang, K. I. 1985. "Behavior of Ontario-Type Bridge Deck on Steel Girders." Ph.D. diss. University of Texas, Austin, TX, December 1985.

Fang, K. I., J. Worley, N. H. Burns, and R. E. Klingner. 1990. "Behavior of Isotropic Reinforced Concrete Bridge Decks on Steel Girders," *Journal of Structural Engineering*, American Society of Civil Engineers, New York, NY, Vol. 116, No. 3, March 1990, pp. 659–678.

FHWA. 2012. *Manual for Design, Construction, and Maintenance of Orthotropic Steel Deck Bridges, Federal Highway Administration*, U.S. Department of Transportation, Washington, DC.

Gangarao, H. V. S., P. R. Raju, and R. Kannekanti. 1993. *Final Report: Static and Fatigue Behavior of Filled and Unfilled Composite Steel Grid Bridge Decks*, Report CFC92-150. West Virginia University, Constructed Facilities Center, Morgantown, WV, December 1993, Volume III.

Gangarao, H. V. S., P. R. Raju, and N. R. Koppula. 1992. "Behavior of Concrete-Filled Steel Grid Decks." In *Transportation Research Record 1371*. Transportation Research Board, National Research Council, Washington, DC.

Hays, C. O., J. M. Lybas, and J. O. Guevara. 1989. *Test of Punching Shear Strength of Lightly Reinforced Orthotropic Bridge Decks*. University of Florida, Gainesville, FL.

Hewitt, B. E., and B. deV Batchelor. 1975. "Punching Shear Strength of Restraint Slabs," *Journal of the Structural Division*. American Society of Civil Engineers, New York, NY, Vol. 101, No. ST9, pp. 1837–1853.

Higgins, C. 2003. "LRFD Orthotropic Plate Model for Determining Live Load Moments in Concrete Filled Grid Bridge Decks," *Journal of Bridge Engineering*. American Society of Civil Engineers, Reston, VA, January/February 2003, pp. 20–28.

Higgins, C. "LRFD Compatible Orthotropic Plate Model for Estimating Deflections in Concrete Filled Grid Bridge Decks." Being submitted for publication.

Higgins, C., and H. Mitchell. 1997. *Tests of a Revised Exodermic Bridge Deck Design*, Report No. 97-16. Clarkson University, Potsdam, NY.

- Higgins, C., and H. Mitchell. 1998. *Fatigue Tests of a Revised Exodermic Bridge Deck Design*, Report No. 98-12. Clarkson University, Potsdam, NY.
- Higgins, C., and H. Mitchell. 2001. "Behavior of Composite Bridge Decks with Alternative Shear Connectors," *Journal of Bridge Engineering*. American Society of Civil Engineers, New York, NY, Vol. 6, No. 1, January/February 2001, pp. 17–22.
- Highway Engineering Division. 1991. *Ontario Highway Bridge Design Code*. Highway Engineering Division, Ministry of Transportation and Communications, Toronto, Canada.
- Holowka, M., R. A. Dorton, and P. F. Csagoly. 1980. *Punching Shear Strength of Restrained Circular Slabs*. Ministry of Transportation and Communication, Downsview, Ontario, Canada.
- IIW. 2007. *Recommendations for Fatigue Design of Welded Joints and Components*, doc. XII-1965-03/XV-1127-03. International Institute of Welding, Paris, France.
- Kim, K. H., J. M. Domingues, R. E. Klingner, and N. H. Burns. 1988. *Behavior of Ontario-Type Bridge Decks on Steel Girders*. University of Texas, Austin, TX.
- Klippstein, Karl H. 1993. *Fatigue Tests and Stain Measurements on Grid Decks*. University of Pittsburgh and Western Pennsylvania Advanced Technology Center and IKG Industries, Volume III.
- Kolstein, M. H. 2007. *Fatigue Classification of Welded Joints in Orthotropic Steel Bridge Decks*, Ph.D. Dissertation. Delft University of Technology, The Netherlands.
- Mangelsdorf, C. P. 1991. *Plate Stiffness Summary and Strain Measurements on Grid Decks, Static and Fatigue Strength Determination of Design Properties for Grid Bridge Decks*, Research Report ST-10. Department of Civil Engineering, University of Pittsburgh, Pittsburgh, PA, December 1991, Volume II.
- Mangelsdorf, C. P. 1996. *Summary and Final Report, Static and Fatigue Strength Determination of Design Properties for Grid Bridge Decks*. Department of Civil and Environmental Engineering, University of Pittsburgh, Pittsburgh, PA, January 1996, Volume IV.
- McLean, D. and M. Marsh. 1988. "Dynamic Impact Factors for Bridges," *National Cooperative Highway Research Program Synthesis of Highway Practice* 266. Transportation Research Board, National Research Council, Washington, DC.
- Menzemer, C., A. Hinkle, and G. Nordmark. 1987. "Aluminum Orthotropic Bridge Deck Verifications." Presented at Materials and Member Behavior, American Society of Civil Engineers, Structures Congress, Orlando, FL, August 17–20, 1987, pp. 298–305.
- Ritter, M. A. 1990. *Timber Bridges, Design, Construction, Inspection and Maintenance*, EM7700-B. U.S. Forest Service, U.S. Department of Agriculture, Washington, DC.
- Sexsmith, R. G., P. D. Boyle, B. Rovner, and R. A. Abbott. 1979. *Load Sharing in Vertically Laminated, Post-Tensioned Bridge Decks*. Forintek Canada Corporation, Vancouver, British Columbia, Canada, April 1979.
- Sim, H. and C. Uang. 2007. *Effects of Fabrication Procedures and Weld Melt-Through on Fatigue Resistance of Orthotropic Steel Deck Welds*, Report No. SSRP-07/13. University of California, San Diego, CA.
- Troitsky, M. S. 1987. *Orthotropic Bridges: Theory and Design*, Second Edition. Lincoln Arc Welding Foundation, Cleveland, OH.
- Wolchuk, R. 1964. *Steel Deck Bridges with Long Rib Spans*. American Society of Civil Engineers, New York, NY, February 1964.
- Wolchuk, R. 1990. "Lessons from Weld Cracks in Orthotropic Decks on Three European Bridges," *Journal of Structural Engineering*. American Society of Civil Engineers, New York, NY, Vol. 117, No. 1, January 1990, pp. 75–84.

Wolchuk, R. 1999. "Steel Orthotropic Decks—Developments in the 1990's." In *Transportation Research Record 1688*. Transportation Research Board, National Research Council, Washington, DC.

Wolchuk, R. and A. Ostapenko. 1992. "Secondary Stresses in Closed Orthotropic Deck Ribs at Floor Beams," *Journal of Structural Engineering*. American Society of Civil Engineers, New York, NY, Vol. 118, No. 2, February 1992, pp. 582–595.

Xiao. 2008. *Effect of Fabrication Procedures and Weld Melt-Through on Fatigue Resistance of Orthotropic Steel Deck Welds, Final Report*, No. CA08-0607. Department of Structural Engineering, University of California, San Diego, CA.

SECTION 10: FOUNDATIONS

TABLE OF CONTENTS

10.1—SCOPE 10-1

10.2—DEFINITIONS..... 10-1

10.3—NOTATION..... 10-3

10.4—SOIL AND ROCK PROPERTIES..... 10-7

 10.4.1—Informational Needs 10-7

 10.4.2—Subsurface Exploration..... 10-8

 10.4.3—Laboratory Tests 10-11

 10.4.3.1—Soil Tests 10-11

 10.4.3.2—Rock Tests 10-11

 10.4.4—In-Situ Tests..... 10-11

 10.4.5—Geophysical Tests..... 10-12

 10.4.6—Selection of Design Properties..... 10-13

 10.4.6.1—General..... 10-13

 10.4.6.2—Soil Strength 10-15

 10.4.6.2.1—General 10-15

 10.4.6.2.2—Undrained Strength of Cohesive Soils..... 10-15

 10.4.6.2.3—Drained Strength of Cohesive Soils..... 10-16

 10.4.6.2.4—Drained Strength of Granular Soils 10-16

 10.4.6.3—Soil Deformation 10-18

 10.4.6.4—Rock Mass Strength..... 10-21

 10.4.6.5—Rock Mass Deformation 10-25

 10.4.6.6—Erodibility of Rock 10-27

10.5—LIMIT STATES AND RESISTANCE FACTORS 10-27

 10.5.1—General..... 10-27

 10.5.2—Service Limit States..... 10-27

 10.5.2.1—General..... 10-27

 10.5.2.2—Tolerable Movements and Movement Criteria 10-28

 10.5.2.3—Overall Stability..... 10-28

 10.5.2.4—Abutment Transitions 10-29

 10.5.3—Strength Limit States 10-29

 10.5.3.1—General..... 10-29

 10.5.3.2—Spread Footings 10-29

 10.5.3.3—Driven Piles 10-30

 10.5.3.4—Drilled Shafts..... 10-30

 10.5.3.5—Micropiles..... 10-30

 10.5.4—Extreme Events Limit States..... 10-31

 10.5.4.1—Extreme Events Design..... 10-31

 10.5.4.2—Liquefaction Design Requirements..... 10-31

 10.5.5—Resistance Factors..... 10-38

 10.5.5.1—Service Limit States 10-38

 10.5.5.2—Strength Limit States 10-38

10.5.5.2.1—General.....	10-38
10.5.5.2.2—Spread Footings	10-39
10.5.5.2.3—Driven Piles.....	10-40
10.5.5.2.4—Drilled Shafts	10-47
10.5.5.2.5—Micropiles	10-49
10.5.5.3—Extreme Limit States.....	10-50
10.5.5.3.1—General.....	10-50
10.5.5.3.2—Scour	10-50
10.5.5.3.3—Other Extreme Limit States	10-51
10.6—SPREAD FOOTINGS.....	10-51
10.6.1—General Considerations	10-51
10.6.1.1—General.....	10-51
10.6.1.2—Bearing Depth	10-51
10.6.1.3—Effective Footing Dimensions.....	10-52
10.6.1.4—Bearing Stress Distributions.....	10-52
10.6.1.5—Anchorage of Inclined Footings.....	10-53
10.6.1.6—Groundwater	10-53
10.6.1.7—Uplift.....	10-53
10.6.1.8—Nearby Structures.....	10-53
10.6.2—Service Limit State Design.....	10-53
10.6.2.1—General.....	10-53
10.6.2.2—Tolerable Movements	10-53
10.6.2.3—Loads.....	10-54
10.6.2.4—Settlement Analyses	10-54
10.6.2.4.1—General.....	10-54
10.6.2.4.2—Settlement of Footings on Cohesionless Soils	10-55
10.6.2.4.3—Settlement of Footings on Cohesive Soils	10-58
10.6.2.4.4—Settlement of Footings on Rock.....	10-63
10.6.2.5—Overall Stability	10-64
10.6.2.6—Bearing Resistance at the Service Limit State.....	10-64
10.6.2.6.1—Presumptive Values for Bearing Resistance	10-64
10.6.2.6.2—Semiempirical Procedures for Bearing Resistance	10-65
10.6.3—Strength Limit State Design	10-66
10.6.3.1—Bearing Resistance of Soil	10-66
10.6.3.1.1—General.....	10-66
10.6.3.1.2—Theoretical Estimation	10-67
10.6.3.1.2a—Basic Formulation.....	10-67
10.6.3.1.2b—Considerations for Punching Shear.....	10-70
10.6.3.1.2c—Considerations for Footings on Slopes.....	10-71
10.6.3.1.2d—Considerations for Two-Layer Soil Systems—Critical Depth.....	10-73
10.6.3.1.2e—Two-Layered Soil System in Undrained Loading.....	10-74
10.6.3.1.2f—Two-Layered Soil System in Drained Loading	10-76
10.6.3.1.3—Semiempirical Procedures	10-76
10.6.3.1.4—Plate Load Tests.....	10-77
10.6.3.2—Bearing Resistance of Rock	10-77

10.6.3.2.1—General	10-77
10.6.3.2.2—Semiempirical Procedures	10-78
10.6.3.2.3—Analytic Method	10-78
10.6.3.2.4—Load Test	10-78
10.6.3.3—Eccentric Load Limitations	10-78
10.6.3.4—Failure by Sliding	10-79
10.6.4—Extreme Event Limit State Design	10-80
10.6.4.1—General	10-80
10.6.4.2—Eccentric Load Limitations	10-81
10.6.5—Structural Design	10-81
10.7—DRIVEN PILES	10-81
10.7.1—General	10-81
10.7.1.1—Application	10-81
10.7.1.2—Minimum Pile Spacing, Clearance, and Embedment into Cap	10-81
10.7.1.3—Piles through Embankment Fill	10-82
10.7.1.4—Batter Piles	10-82
10.7.1.5—Pile Design Requirements	10-82
10.7.1.6—Determination of Pile Loads	10-83
10.7.1.6.1—General	10-83
10.7.1.6.2—Downdrag	10-83
10.7.1.6.3—Uplift Due to Expansive Soils	10-83
10.7.1.6.4—Nearby Structures	10-84
10.7.2—Service Limit State Design	10-84
10.7.2.1—General	10-84
10.7.2.2—Tolerable Movements	10-84
10.7.2.3—Settlement	10-84
10.7.2.3.1—Equivalent Footing Analogy	10-84
10.7.2.3.2—Pile Groups in Cohesive Soil	10-86
10.7.2.4—Horizontal Pile Foundation Movement	10-87
10.7.2.5—Settlement Due to Downdrag	10-89
10.7.2.6—Lateral Squeeze	10-89
10.7.3—Strength Limit State Design	10-89
10.7.3.1—General	10-89
10.7.3.2—Point Bearing Piles on Rock	10-90
10.7.3.2.1—General	10-90
10.7.3.2.2—Piles Driven to Soft Rock	10-90
10.7.3.2.3—Piles Driven to Hard Rock	10-90
10.7.3.3—Pile Length Estimates for Contract Documents	10-91
10.7.3.4—Nominal Axial Resistance Change after Pile Driving	10-93
10.7.3.4.1—General	10-93
10.7.3.4.2—Relaxation	10-93
10.7.3.4.3—Setup	10-93
10.7.3.5—Groundwater Effects and Buoyancy	10-94
10.7.3.6—Scour	10-94
10.7.3.7—Downdrag	10-95

10.7.3.8—Determination of Nominal Bearing Resistance for Piles	10-96
10.7.3.8.1—General	10-96
10.7.3.8.2—Static Load Test	10-97
10.7.3.8.3—Dynamic Testing	10-97
10.7.3.8.4—Wave Equation Analysis	10-98
10.7.3.8.5—Dynamic Formula	10-99
10.7.3.8.6—Static Analysis	10-100
10.7.3.8.6a—General	10-100
10.7.3.8.6b— α -Method	10-101
10.7.3.8.6c— β -Method	10-102
10.7.3.8.6d— λ -Method	10-102
10.7.3.8.6e—Tip Resistance in Cohesive Soils	10-103
10.7.3.8.6f—Nordlund/Thurman Method in Cohesionless Soils	10-103
10.7.3.8.6g—Using SPT or CPT in Cohesionless Soils	10-108
10.7.3.9—Resistance of Pile Groups in Compression	10-112
10.7.3.10—Uplift Resistance of Single Piles	10-114
10.7.3.11—Uplift Resistance of Pile Groups	10-114
10.7.3.12—Nominal Lateral Resistance of Pile Foundations	10-116
10.7.3.13—Pile Structural Resistance	10-117
10.7.3.13.1—Steel Piles	10-117
10.7.3.13.2—Concrete Piles	10-117
10.7.3.13.3—Timber Piles	10-118
10.7.3.13.4—Buckling and Lateral Stability	10-118
10.7.4—Extreme Event Limit State	10-118
10.7.5—Corrosion and Deterioration	10-119
10.7.6—Determination of Minimum Pile Penetration	10-120
10.7.7—Determination of R_{ndr} Used to Establish Contract Driving Criteria for Nominal Bearing Resistance	10-121
10.7.8—Drivability Analysis	10-121
10.7.9—Probe Piles	10-123
10.8—DRILLED SHAFTS	10-123
10.8.1—General	10-123
10.8.1.1—Scope	10-123
10.8.1.2—Shaft Spacing, Clearance, and Embedment into Cap	10-124
10.8.1.3—Shaft Diameter and Enlarged Bases	10-124
10.8.1.4—Battered Shafts	10-124
10.8.1.5—Drilled Shaft Resistance	10-125
10.8.1.6—Determination of Shaft Loads	10-126
10.8.1.6.1—General	10-126
10.8.1.6.2—Downdrag	10-126
10.8.1.6.3—Uplift	10-126
10.8.2—Service Limit State Design	10-126
10.8.2.1—Tolerable Movements	10-126
10.8.2.2—Settlement	10-126
10.8.2.2.1—General	10-126

10.8.2.2.2—Settlement of Single-Drilled Shaft.....	10-127
10.8.2.2.3—Intermediate Geo Materials (IGMs)	10-129
10.8.2.2.4—Group Settlement.....	10-130
10.8.2.3—Horizontal Movement of Shafts and Shaft Groups.....	10-130
10.8.2.4—Settlement Due to Downdrag.....	10-130
10.8.2.5—Lateral Squeeze.....	10-130
10.8.3—Strength Limit State Design.....	10-130
10.8.3.1—General.....	10-130
10.8.3.2—Groundwater Table and Buoyancy	10-130
10.8.3.3—Scour.....	10-130
10.8.3.4—Downdrag	10-130
10.8.3.5—Nominal Axial Compression Resistance of Single Drilled Shafts.....	10-131
10.8.3.5.1—Estimation of Drilled Shaft Resistance in Cohesive Soils.....	10-131
10.8.3.5.1a—General.....	10-131
10.8.3.5.1b—Side Resistance.....	10-132
10.8.3.5.1c—Tip Resistance.....	10-133
10.8.3.5.2—Estimation of Drilled Shaft Resistance in Cohesionless Soils.....	10-134
10.8.3.5.2a—General.....	10-134
10.8.3.5.2b—Side Resistance.....	10-134
10.8.3.5.2c—Tip Resistance.....	10-135
10.8.3.5.3—Shafts in Strong Soil Overlying Weaker Compressible Soil	10-136
10.8.3.5.4—Estimation of Drilled Shaft Resistance in Rock	10-136
10.8.3.5.4a—General.....	10-136
10.8.3.5.4b—Side Resistance.....	10-137
10.8.3.5.4c—Tip Resistance.....	10-138
10.8.3.5.4d—Combined Side and Tip Resistance	10-138
10.8.3.5.5—Estimation of Drilled Shaft Resistance in Intermediate Geo Materials (IGMs)	10-139
10.8.3.5.6—Shaft Load Test.....	10-139
10.8.3.6—Shaft Group Resistance.....	10-140
10.8.3.6.1—General	10-140
10.8.3.6.2—Cohesive Soil.....	10-140
10.8.3.6.3—Cohesionless Soil.....	10-141
10.8.3.6.4—Shaft Groups in Strong Soil Overlying Weak Soil	10-141
10.8.3.7—Uplift Resistance.....	10-142
10.8.3.7.1—General	10-142
10.8.3.7.2—Uplift Resistance of Single Drilled Shaft	10-142
10.8.3.7.3—Group Uplift Resistance	10-143
10.8.3.7.4—Uplift Load Test.....	10-143
10.8.3.8—Nominal Horizontal Resistance of Shaft and Shaft Groups.....	10-143
10.8.3.9—Shaft Structural Resistance	10-143
10.8.3.9.1—General	10-143
10.8.3.9.2—Buckling and Lateral Stability.....	10-143
10.8.3.9.3—Reinforcement	10-143
10.8.3.9.4—Transverse Reinforcement.....	10-144
10.8.3.9.5—Concrete.....	10-144
10.8.3.9.6—Reinforcement into Superstructure.....	10-144

10.8.3.9.7—Enlarged Bases.....	10-144
10.8.4—Extreme Event Limit State	10-144
10.9—MICROPILES	10-145
10.9.1—General.....	10-145
10.9.1.1—Scope.....	10-146
10.9.1.2—Minimum Micropile Spacing, Clearance, and Embedment into Cap.....	10-146
10.9.1.3—Micropiles through Embankment Fill	10-146
10.9.1.4—Battered Micropiles.....	10-146
10.9.1.5—Micropile Design Requirements	10-146
10.9.1.6—Determination of Micropile Loads.....	10-147
10.9.1.6.1—Downdrag	10-147
10.9.1.6.2—Uplift Due to Expansive Soils.....	10-147
10.9.1.6.3—Nearby Structures	10-147
10.9.2—Service Limit State Design.....	10-147
10.9.2.1—General	10-147
10.9.2.2—Tolerable Movements	10-147
10.9.2.3—Settlement	10-147
10.9.2.3.1—Micropile Groups in Cohesive Soil.....	10-147
10.9.2.3.2—Micropile Groups in Cohesionless Soil.....	10-147
10.9.2.4—Horizontal Micropile Foundation Movement	10-147
10.9.2.5—Settlement Due to Downdrag.....	10-147
10.9.2.6—Lateral Squeeze	10-147
10.9.3—Strength Limit State Design.....	10-148
10.9.3.1—General.....	10-148
10.9.3.2—Ground Water Table and Bouyancy.....	10-148
10.9.3.3—Scour	10-148
10.9.3.4—Downdrag.....	10-148
10.9.3.5—Nominal Axial Compression Resistance of a Single Micropile.....	10-148
10.9.3.5.1—General.....	10-148
10.9.3.5.2—Estimation of Grout-to-Ground Bond Resistance	10-149
10.9.3.5.3—Estimation of Micropile Tip Resistance in Rock	10-150
10.9.3.5.4—Micropile Load Test.....	10-151
10.9.3.6—Resistance of Micropile Groups in Compression.....	10-151
10.9.3.7—Nominal Uplift Resistance of a Single Micropile	10-151
10.9.3.8—Nominal Uplift Resistance of Micropile Groups	10-151
10.9.3.9—Nominal Horizontal Resistance of Micropiles and Micropile Groups	10-152
10.9.3.10—Structural Resistance.....	10-152
10.9.3.10.1—General.....	10-152
10.9.3.10.2—Axial Compressive Resistance.....	10-152
10.9.3.10.2a—Cased Length	10-153
10.9.3.10.2b—Uncased Length	10-153
10.9.3.10.3—Axial Tension Resistance.....	10-154
10.9.3.10.3a—Cased Length	10-154
10.9.3.10.3b—Uncased Length	10-155
10.9.3.10.4—Plunge Length Transfer Load	10-155

10.9.3.10.5—Grout-to-Steel Bond	10-156
10.9.3.10.6—Buckling and Lateral Stability	10-156
10.9.3.10.7—Reinforcement into Superstructure	10-156
10.9.4—Extreme Event Limit State	10-156
10.9.5—Corrosion and Deterioration	10-156
10.10—REFERENCES	10-156
APPENDIX A10—SEISMIC ANALYSIS AND DESIGN OF FOUNDATIONS	10-163
A10.1—INVESTIGATION	10-163
A10.2—FOUNDATION DESIGN	10-163
A10.3—SPECIAL PILE REQUIREMENTS	10-167

SECTION 10
FOUNDATIONS

10.1—SCOPE

Provisions of this Section shall apply for the design of spread footings, driven piles, drilled shaft, and micropile foundations.

The probabilistic LRFD basis of these Specifications, which produces an interrelated combination of load, load factor resistance, resistance factor, and statistical reliability, shall be considered when selecting procedures for calculating resistance other than that specified herein. Other methods, especially when locally recognized and considered suitable for regional conditions, may be used if resistance factors are developed in a manner that is consistent with the development of the resistance factors for the method(s) provided in these Specifications, and are approved by the Owner.

10.2—DEFINITIONS

Battered Pile—A pile or micropile installed at an angle inclined to the vertical to provide higher resistance to lateral loads.

Bearing Pile—A pile or micropile whose purpose is to carry axial load through friction or point bearing.

Bent—A type of pier comprised of multiple columns or piles supporting a single cap and in some cases connected with bracing.

Bent Cap—A flexural substructure element supported by columns or piles that receives loads from the superstructure.

Bond Length—The length of a micropile that is bonded to the ground and which is conceptually used to transfer the applied axial loads to the surrounding soil or rock. Also known as the load transfer length.

Casing—Steel pipe introduced during the drilling process to temporarily stabilize the drill hole. Depending on the details of micropile construction and composition, this casing may be fully extracted during or after grouting, or may remain partially or completely in place as part of the final micropile pile configuration.

Centralizer—A device to centrally locate the core steel within a borehole.

Column Bent—A type of bent that uses two or more columns to support a cap. Columns may be drilled shafts or other independent units supported by individual footings or a combined footing; and may employ bracing or struts for lateral support above ground level.

Combination Point Bearing and Friction Pile—Pile that derives its capacity from contributions of both point bearing developed at the pile tip and resistance mobilized along the embedded shaft.

Combined Footing—A footing that supports more than one column.

Core Steel—Reinforcing bars or pipes used to strengthen or stiffen a micropile, excluding any left-in casing.

CPT—Cone Penetration Test.

CU—Consolidated Undrained.

Deep Foundation—A foundation that derives its support by transferring loads to soil or rock at some depth below the structure by end bearing, adhesion or friction, or both.

DMT—Flat Plate Dilatometer Test.

C10.1

The development of the resistance factors provided in this Section are summarized in Allen (2005), with additional details provided in Appendix A of Barker et al. (1991), in Paikowsky et al. (2004), in Allen (2005), and in D'Appolonia (2006).

The specification of methods of analysis and calculation of resistance for foundations herein is not intended to imply that field verification and/or reaction to conditions actually encountered in the field are no longer needed. These traditional features of foundation design and construction are still practical considerations when designing in accordance with these Specifications.

Drilled Shaft—A deep foundation unit, wholly or partly embedded in the ground, constructed by placing fresh concrete in a drilled hole with or without steel reinforcement. Drilled shafts derive their capacity from the surrounding soil and/or from the soil or rock strata below its tip. Drilled shafts are also commonly referred to as caissons, drilled caissons, bored piles, or drilled piers.

Effective Stress—The net stress across points of contact of soil particles, generally considered as equivalent to the total stress minus the pore water pressure.

ER—Hammer efficiency expressed as percent of theoretical free fall energy delivered by the hammer system actually used in a Standard Penetration Test.

Free (Unbonded) Length—The designed length of a micropile that is not bonded to the surrounding ground or grout.

Friction Pile—A pile whose support capacity is derived principally from soil resistance mobilized along the side of the embedded pile.

Geomechanics Rock Mass Rating System—Rating system developed to characterize the engineering behavior of rock masses (Bieniawski, 1984).

Geotechnical Bond Strength—The nominal grout-to-ground bond strength.

IGM—Intermediate Geomaterial, a material that is transitional between soil and rock in terms of strength and compressibility, such as residual soils, glacial tills, or very weak rock.

Isolated Footing—Individual support for the various parts of a substructure unit; the foundation is called a footing foundation.

Length of Foundation—Maximum plan dimension of a foundation element.

Load Test—Incremental loading of a foundation element, recording the total movement at each increment.

Micropile—A small-diameter drilled and grouted non-displacement pile (normally less than 12 in.) that is typically reinforced.

OCR—Over Consolidation Ratio, the ratio of the preconsolidation pressure to the current vertical effective stress.

Pile—A slender deep foundation unit, wholly or partly embedded in the ground, that is installed by driving, drilling, auguring, jetting, or otherwise and that derives its capacity from the surrounding soil and/or from the soil or rock strata below its tip.

Pile Bent—A type of bent using pile units, driven or placed, as the column members supporting a cap.

Pile Cap—A flexural substructure element located above or below the finished ground line that receives loads from substructure columns and is supported by shafts or piles.

Pile Shoe—A metal piece fixed to the penetration end of a pile to protect it from damage during driving and to facilitate penetration through very dense material.

Piping—Progressive erosion of soil by seeping water that produces an open pipe through the soil through which water flows in an uncontrolled and dangerous manner.

Plunge Length—The length of casing inserted into the bond zone to effect a transition between the upper cased portion to the lower uncased portion of a micropile.

Plunging—A mode of behavior observed in some pile load tests, wherein the settlement of the pile continues to increase with no increase in load.

PMT—Pressuremeter Test.

Point-Bearing Pile—A pile whose support capacity is derived principally from the resistance of the foundation material on which the pile tip bears.

Post Grouting—The injection of additional grout into the load bond length of a micropile after the primary grout has set. Also known as regrouting or secondary grouting.

Primary Grout—Portland cement-based grout that is injected into a micropile hole, prior to or after the installation of the reinforcement to provide the load transfer to the surrounding ground along the micropile and afford a degree of corrosion protection for a micropile loaded in compression.

Reinforcement—The steel component of a micropile which accepts and/or resists applied loadings.

RMR—Rock Mass Rating.

RQD—Rock Quality Designation.

Shallow Foundation—A foundation that derives its support by transferring load directly to the soil or rock at shallow depth.

Slickensides—Polished and grooved surfaces in clayey soils or rocks resulting from shearing displacements along planes.

SPT—Standard Penetration Test.

Total Stress—Total pressure exerted in any direction by both soil and water.

UU—Unconsolidated Undrained.

VST—Vane Shear Test (performed in the field).

Width of Foundation—Minimum plan dimension of a foundation element.

10.3—NOTATION

A	=	steel pile cross-sectional area (ft ²) (10.7.3.8.2)
A_b	=	cross-sectional area of steel reinforcing bar (in. ²) (10.9.3.10.2a)
A_c	=	cross-sectional area of steel casing (in. ²) (10.9.3.10.2a)
A_{ct}	=	cross-sectional area of steel casing considering reduction for threads (in. ²) (10.9.3.10.3a)
A_g	=	cross-sectional area of grout within micropile (in. ²) (10.9.3.10.3a)
A_p	=	area of pile or micropile tip or base of drilled shaft (ft ²) (10.7.3.8.6a) (10.8.3.5) (10.9.3.5.1)
A_s	=	surface area of pile shaft; area of grout to ground bond surface of micropile through bond length (ft ²) (10.7.3.8.6a) (10.9.3.5.1)
A_u	=	uplift area of a belled drilled shaft (ft ²) (10.8.3.7.2)
A'	=	effective footing area for determination of elastic settlement of footing subjected to eccentric loads (ft ²) (10.6.2.4.2)
a_{si}	=	pile perimeter at the point considered (ft) (10.7.3.8.6g)
B	=	footing width; pile group width; pile diameter (ft) (10.6.1.3) (10.7.2.3.2) (10.7.2.4)
B'	=	effective footing width (ft) (10.6.1.3)
C_α	=	secondary compression index, void ratio definition (dim) (10.4.6.3)
$C_{\alpha\varepsilon}$	=	secondary compression index, strain definition (dim) (10.6.2.4.3)
C_c	=	compression index, void ratio definition (dim) (10.4.6.3)
$C_{c\varepsilon}$	=	compression index, strain definition (dim) (10.6.2.4.3)
C_F	=	correction factor for K_δ when δ is not equal to ϕ_f (dim) (10.7.3.8.6f)
C_N	=	overburden stress correction factor for N (dim) (10.4.6.2.4)
C_r	=	recompression index, void ratio definition (dim) (10.4.6.3)
$C_{r\varepsilon}$	=	recompression index, strain definition (dim) (10.6.2.4.3)
$C_{wq}, C_{w\gamma}$	=	correction factors for groundwater effect (dim) (10.6.3.1.2a)
C'	=	bearing capacity index (dim) (10.6.2.4.2)
c	=	cohesion of soil taken as undrained shear strength (ksf) (10.6.3.1.2a)
c_v	=	coefficient of consolidation (ft ² /yr) (10.4.6.3)
c_1	=	undrained shear strength of the top layer of soil as depicted in Figure 10.6.3.1.2e-1 (ksf) (10.6.3.1.2e)
c_2	=	undrained shear strength of the lower layer of soil as depicted in Figure 10.6.3.1.2e-1 (ksf) (10.6.3.1.2e)
c'_1	=	drained shear strength of the top layer of soil (ksf) (10.6.3.1.2f)
c^*	=	reduced effective stress soil cohesion for punching shear (ksf) (10.6.3.1.2b)

c'	=	effective stress cohesion intercept (ksf) (10.4.6.2.3)
c'_i	=	instantaneous cohesion at a discrete value of normal stress (ksf) (C10.4.6.4)
D	=	depth of pile embedment; pile width or diameter; diameter of drilled shaft (ft) (10.7.2.3) (10.7.3.8.6g) (10.8.3.5.1c)
DD	=	downdrag load per pile (kips) (C10.7.3.7)
D'	=	effective depth of pile or micropile group (ft) (10.7.2.3.2) (10.9.2.3.2)
D_b	=	depth of embedment of pile into a bearing stratum (ft) (10.7.2.3.2)
D_{est}	=	estimated pile length needed to obtain desired nominal resistance per pile (ft) (C10.7.3.7)
D_f	=	foundation embedment depth taken from ground surface to bottom of footing (ft) (10.6.3.1.2a)
D_i	=	pile width or diameter at the point considered (ft) (10.7.3.8.6g)
D_p	=	diameter of the bell on a belled drilled shaft (ft) (10.8.3.7.2)
D_r	=	relative density (percent) (C10.6.3.1.2b)
D_w	=	depth to water surface taken from the ground surface (ft) (10.6.3.1.2a)
d_b	=	grouted bond zone diameter (ft) (10.9.3.5.2)
d_q	=	correction factor to account for the shearing resistance along the failure surface passing through cohesionless material above the bearing elevation (dim) (10.6.3.1.2a)
E	=	modulus of elasticity of pile material (ksi) (10.7.3.8.2)
E_d	=	developed hammer energy (ft-lb) (10.7.3.8.5)
E_i	=	modulus of elasticity of intact rock (ksi) (10.4.6.5)
E_m	=	rock mass modulus (ksi) (10.4.6.5)
E_p	=	modulus of elasticity of pile (ksi) (10.7.3.13.4)
ER	=	hammer efficiency expressed as percent of theoretical free fall energy delivered by the hammer system actually used (dim) (10.4.6.2.4)
E_s	=	soil (Young's) modulus (ksi) (C10.4.6.3)
e	=	void ratio (dim) (10.6.2.4.3)
e_B	=	eccentricity of load parallel to the width of the footing (ft) (10.6.1.3)
e_L	=	eccentricity of load parallel to the length of the footing (ft) (10.6.1.3)
e_o	=	void ratio at initial vertical effective stress (dim) (10.6.2.4.3)
F_{CO}	=	base resistance of wood in compression parallel to the grain (ksi) (10.7.8)
f'_c	=	28-day compressive strength of concrete or grout, unless another age is specified (ksi) (10.6.2.6.2) (10.9.3.10.2a)
f_{pe}	=	effective stress in the prestressing steel after losses (ksi) (10.7.8)
f_s	=	approximate constant sleeve friction resistance measured from a <i>CPT</i> at depths below $8D$ (ksf) (C10.7.3.8.6g)
f_{si}	=	unit local sleeve friction resistance from <i>CPT</i> at the point considered (ksf) (10.7.3.8.6g)
f_y	=	specified minimum yield strength of steel (ksi) (10.7.8) (10.9.3.10.2a)
H	=	horizontal component of inclined loads (kips) (10.6.3.1.2a)
H_c	=	height of compressible soil layer (ft) (10.6.2.4.2)
H_{crit}	=	minimum distance below a spread footing to a second separate layer of soil with different properties that will affect shear strength of the foundation (ft) (10.6.3.1.2d)
H_d	=	length of longest drainage path in compressible soil layer (ft) (10.6.2.4.3)
H_s	=	height of sloping ground mass (ft) (10.6.3.1.2c)
H_{s2}	=	distance from bottom of footing to top of the second soil layer (ft) (10.6.3.1.2e)
h_i	=	length interval at the point considered (ft) (10.7.3.8.6g)
I	=	influence factor of the effective group embedment (dim) (10.7.2.3.2)
I_p	=	influence coefficient to account for rigidity and dimensions of footing (dim) (10.6.2.4.4)
I_w	=	weak axis moment of inertia for a pile (ft ⁴) (10.7.3.13.4)
i_c, i_q, i_γ	=	load inclination factors (dim) (10.6.3.1.2a)
j	=	damping constant (dim) (10.7.3.8.3)
K_c	=	correction factor for side friction in clay (dim) (10.7.3.8.6g)
K_s	=	correction factor for side friction in sand (dim) (10.7.3.8.6g)
K_δ	=	coefficient of lateral earth pressure at midpoint of soil layer under consideration (dim) (10.7.3.8.6f)
L	=	length of foundation; pile length (ft) (10.6.1.3) (10.7.3.8.2)
L_b	=	micropile bonded length (ft) (10.9.3.5.2)
L_i	=	depth to middle of length interval at the point considered (ft) (10.7.3.8.6g)
L_p	=	micropile casing plunge length (ft) (10.9.3.10.4)
L'	=	effective footing length (ft) (10.6.1.3)
LL	=	liquid limit of soil (percent) (10.4.6.3)
N	=	uncorrected Standard Penetration Test (<i>SPT</i>) blow count (blows/ft) (10.4.6.2.4)

\bar{N}_{160}	=	average corrected <i>SPT</i> blow count along pile side (blows/ft) (10.7.3.8.6g)
N_1	=	<i>SPT</i> blow count corrected for overburden pressure σ' , (blows/ft) (10.4.6.2.4)
N_{160}	=	<i>SPT</i> blow count corrected for both overburden and hammer efficiency effects (blows/ft) (10.4.6.2.4) (10.7.2.3.2)
N_b	=	number of hammer blows for 1 in. of pile permanent set (blows/in.) (10.7.3.8.5)
N_c	=	cohesion term (undrained loading) bearing capacity factor (dim) (10.6.3.1.2a)
N_{cm}, N_{qm}		
$N_{\gamma m}$	=	modified bearing capacity factors (dim) (10.6.3.1.2a)
N_{cq}	=	modified bearing capacity factor (dim) (10.6.3.1.2e)
N_m	=	modified bearing capacity factor (dim) (10.6.3.1.2e)
N_s	=	slope stability factor (dim) (10.6.3.1.2c)
N_q	=	surcharge (embedment) term (drained or undrained loading) bearing capacity factor (dim) (10.6.3.1.2a)
N_u	=	uplift adhesion factor for bell (dim) (10.8.3.7.2)
N'	=	alternate notation for N_1 (blows/ft) (10.6.2.4.2)
N'_q	=	pile bearing capacity factor from Figure 10.7.3.8.6f-8 (dim) (10.7.3.8.6f)
N_γ	=	unit weight (footing width) term (drained loading) bearing capacity factor (dim) (10.6.3.1.2a)
N_1	=	number of intervals between the ground surface and a point $8D$ below the ground surface (dim) (10.7.3.8.6g)
N_2	=	number of intervals between $8D$ below the ground surface and the tip of the pile (dim) (10.7.3.8.6g)
N_{60}	=	<i>SPT</i> blow count corrected for hammer efficiency (blows/ft) (10.4.6.2.4)
n	=	porosity (dim); number of soil layers within zone of stress influence of the footing (dim) (10.4.6.2.4) (10.6.2.4.2)
n_h	=	rate of increase of soil modulus with depth (ksi/ft) (10.4.6.3)
PL	=	plastic limit of soil (percent) (10.4.6.3)
P_f	=	probability of failure (dim) (C10.5.5.2.1)
P_m	=	p -multiplier from Table 10.7.2.4-1 (dim) (10.7.2.4)
P_t	=	factored axial load transferred to ground along micropile plunge length (kips) (10.9.3.10.4)
P_u	=	factored axial load on uncased micropile segment adjusted for plunge length load transfer (10.9.3.10.4)
p_a	=	atmospheric pressure (ksf) (Sea level value equivalent to 2.12 ksf or 1 atm or 14.7 psi) (10.8.3.5.1b)
Q	=	load applied to top of footing, shaft, or micropile (kips); load test load (kips) (C10.6.3.1.2b) (10.7.3.8.2) (10.9.3.10.4)
Q_f	=	load at failure during load test (kips) (10.7.3.8.2)
Q_g	=	bearing capacity for block failure (kips) (C10.7.3.9)
Q_p	=	factored load per pile, excluding downdrag load (kips) (C10.7.3.7)
Q_{T1}	=	total load acting at the head of the drilled shaft (kips) (C10.8.3.5.4d)
q	=	net foundation pressure applied at $2D_b/3$; this pressure is equal to applied load at top of the group divided by the area of the equivalent footing and does not include the weight of the piles or the soil between the piles (ksf) (10.7.2.3.2)
q_c	=	static cone tip resistance (ksf) (C10.4.6.3)
\bar{q}_c	=	average static cone tip resistance over a depth B below the equivalent footing (ksf) (10.6.3.1.3)
q_{c1}	=	average q_c over a distance of yD below the pile tip (path a-b-c) (ksf) (10.7.3.8.6g)
q_{c2}	=	average q_c over a distance of $8D$ above the pile tip (path c-e) (ksf) (10.7.3.8.6g)
q_L	=	limiting unit tip resistance of a single pile from Figure 10.7.3.8.6f-9 (ksf) (10.7.3.8.6f)
q_ℓ	=	limiting tip resistance of a single pile (ksf) (10.7.3.8.6g)
q_n	=	nominal bearing resistance (ksf) (10.6.3.1.1)
q_o	=	applied vertical stress at base of loaded area (ksf) (10.6.2.4.2)
q_p	=	nominal unit tip resistance of pile or micropile (ksf) (10.7.3.8.6a) (10.9.3.5.1)
q_R	=	factored bearing resistance (ksf) (10.6.3.1.1)
q_s	=	unit shear resistance (ksf); unit side resistance of pile or micropile (ksf) (10.6.3.4) (10.7.3.8.6a) (10.9.3.5.1)
q_{sbell}	=	nominal unit uplift resistance of a belled drilled shaft (ksf) (10.8.3.7.2)
q_u	=	uniaxial compression strength of rock (ksf) (10.4.6.4)
q_{ult}	=	nominal bearing resistance (ksf) (10.6.3.1.2e)
q_1	=	nominal bearing resistance of footing supported in the upper layer of a two-layer system, assuming the upper layer is infinitely thick (ksf) (10.6.3.1.2d)
q_2	=	nominal bearing resistance of a fictitious footing of the same size and shape as the actual footing but supported on surface of the second (lower) layer of a two-layer system (ksf) (10.6.3.1.2d)

R_C	=	factored micropile structural axial compression resistance (kips) (10.9.3.10.2)
R_{CC}	=	factored structural axial compression resistance of cased micropile segments (kips) (10.9.3.10.2a)
R_{CU}	=	factored structural axial compression resistance of uncased micropile segments (kips) (10.9.3.10.2b)
R_{ep}	=	nominal passive resistance of soil available throughout the design life of the structure (kips) (10.6.3.4)
R_n	=	nominal resistance of footing, pile, shaft, or micropile (kips) (10.6.3.4)
R_{ndr}	=	nominal pile driving resistance including downdrag (kips) (C10.7.3.3)
R_{nstat}	=	nominal resistance of pile from static analysis method (kips) (C10.7.3.3)
R_p	=	nominal pile or micropile tip resistance (kips) (10.7.3.8.6a) (10.9.3.5.1)
R_R	=	factored nominal resistance of a footing, pile, micropile, or shaft (kips) (10.6.3.4) (10.9.3.5.1)
R_s	=	pile side resistance (kips); nominal uplift resistance due to side resistance (kips); nominal micropile grout-to-ground bond resistance (kips) (10.7.3.8.6a) (10.7.3.10) (C10.9.3.5.1)
R_{sbell}	=	nominal uplift resistance of a belled drilled shaft (kips) (10.8.3.5.2)
R_{sdd}	=	skin friction which must be overcome during driving (kips) (C10.7.3.7)
R_T	=	factored structural axial tension resistance (kips) (10.9.3.10.3)
R_{TC}	=	factored structural axial tension resistance of cased micropile segments (kips) (10.9.3.10.3a)
R_{TU}	=	factored structural axial tension resistance of uncased micropile segments (kips) (10.9.3.10.3b)
R_{ug}	=	nominal uplift resistance of a pile group (kips) (10.7.3.11)
R_τ	=	nominal sliding resistance between the footing and the soil (kips) (10.6.3.4)
r	=	radius of circular footing or $B/2$ for square footing (ft) (10.6.2.4.4)
S_c	=	primary consolidation settlement (ft) (10.6.2.4.1)
$S_{c(1-D)}$	=	single dimensional consolidation settlement (ft) (10.6.2.4.3)
S_e	=	elastic settlement (ft) (10.6.2.4.1)
S_s	=	secondary settlement (ft) (10.6.2.4.1)
S_t	=	total settlement (ft) (10.6.2.4.1)
S_u	=	undrained shear strength (ksf) (10.4.6.2.2)
\bar{S}_u	=	average undrained shear strength along pile side (ksf) (10.7.3.9)
s	=	pile permanent set (in.) (10.7.3.8.5)
s, m	=	fractured rock mass parameters (10.4.6.4)
s_c, s_q, s_γ	=	shape factors (dim) (10.6.3.1.2a)
s_f	=	pile top movement during load test (in.) (10.7.3.8.2)
T	=	time factor (dim) (10.6.2.4.3)
t	=	time for a given percentage of one-dimensional consolidation settlement to occur (yr) (10.6.2.4.3)
t_1, t_2	=	arbitrary time intervals for determination of secondary settlement, S_s (yr) (10.6.2.4.3)
U	=	percentage of consolidation (10.6.2.4.3)
V	=	total vertical force applied by a footing (kips); pile displacement volume (ft ³ /ft) (10.6.3.1.2a) (10.7.3.8.6f)
W_g	=	weight of block of soil, piles and pile cap (kips) (10.7.3.11)
W_{T1}	=	vertical movement at the head of the drilled shaft (in.) (C10.8.3.5.4d)
X	=	width or smallest dimension of pile group (ft) (10.7.3.9)
Y	=	length of pile group (ft) (10.7.3.9)
Z	=	total embedded pile length; penetration of shaft (ft) (10.7.3.8.6g)
z	=	depth below ground surface (ft) (C10.4.6.3)
α	=	adhesion factor applied to s_u (dim) (10.7.3.8.6b)
α_b	=	nominal micropile grout-to-ground bond stress (ksf) (10.9.3.5.2)
α_E	=	reduction factor to account for jointing in rock (dim) (10.8.3.5.4b)
α_t	=	coefficient from Figure 10.7.3.8.6f-7 (dim) (10.7.3.8.6f)
β	=	reliability index; coefficient relating the vertical effective stress and the unit skin friction of a pile or drilled shaft (dim) (C10.5.5.2.1) (10.7.3.8.6c)
β_m	=	punching index (dim) (10.6.3.1.2e)
β_z	=	factor to account for footing shape and rigidity (dim) (10.6.2.4.2)
γ	=	unit density of soil (kcf) (10.6.3.1.2a)
γ_p	=	load factor for downdrag (C10.7.3.7)
ΔH_i	=	elastic settlement of layer i (ft) (10.6.2.4.2)
δ	=	elastic deformation of pile (in.); friction angle between foundation and soil (degrees) (C10.7.3.8.2) (10.7.3.8.6f)
ϵ_v	=	vertical strain of over consolidated soil (in./in.) (10.6.2.4.3)

η	=	shaft efficiency reduction factor for axial resistance of a drilled shaft or micropile group (dim) (10.7.3.9)
λ	=	empirical coefficient relating the passive lateral earth pressure and the unit skin friction of a pile (dim) (10.7.3.8.6d)
μ_c	=	reduction factor for consolidation settlements to account for three-dimensional effects (dim) (10.6.2.4.3)
ϕ_f	=	angle of internal friction of drained soil (degrees) (10.4.6.2.4)
ϕ'_f	=	drained (long term) effective angle of internal friction of clays (degrees) (10.4.6.2.3)
ϕ'_i	=	instantaneous friction angle of the rock mass (degrees) (10.4.6.4)
ϕ'_1	=	effective stress angle of internal friction of the top layer of soil (degrees) (10.6.3.1.2f)
ϕ'_s	=	secant friction angle (degrees) (10.4.6.2.4)
ϕ^*	=	reduced effective stress soil friction angle for punching shear (degrees) (10.6.3.1.2b)
ϕ	=	resistance factor (dim) (10.5.5.2.3)
ϕ_b	=	resistance factor for bearing of shallow foundations (dim) (10.5.5.2.2)
ϕ_{bl}	=	resistance factor for driven piles or shafts, block failure in clay (dim) (10.5.5.2.3)
ϕ_C	=	structural resistance factor for micropiles in axial compression (dim) (10.9.3.10.2)
ϕ_{CC}	=	structural resistance factor for cased micropiles segments in axial compression (dim) (10.9.3.10.2a)
ϕ_{CU}	=	structural resistance factor for uncased micropiles segments in axial compression (dim) (10.9.3.10.2b)
ϕ_{da}	=	resistance factor for driven piles, drivability analysis (dim) (10.5.5.2.3)
ϕ_{dyn}	=	resistance factor for driven piles, dynamic analysis and static load test methods (dim) (10.5.5.2.3)
ϕ_{ep}	=	resistance factor for passive soil resistance (dim) (10.5.5.2.2)
ϕ_{load}	=	resistance factor for shafts, static load test (dim) (10.5.5.2.4)
ϕ_{qp}	=	resistance factor for tip resistance (dim) (10.8.3.5) (10.9.3.5.1)
ϕ_{qs}	=	resistance factor for shaft side resistance (dim) (10.8.3.5)
ϕ_{stat}	=	resistance factor for driven piles or shafts, static analysis methods (dim) (10.5.5.2.3)
ϕ_T	=	structural resistance factor for micropiles in axial tension (dim) (10.9.3.10.3)
ϕ_{TC}	=	structural resistance factor for cased micropiles segments in axial tension (dim) (10.9.3.10.3a)
ϕ_{TU}	=	structural resistance factor for uncased micropiles segments in axial tension (dim) (10.9.3.10.3b)
ϕ_{ug}	=	resistance factor for group uplift (dim) (10.5.5.2.3)
ϕ_{up}	=	resistance factor for uplift resistance of a single pile or drilled shaft (dim) (10.5.5.2.3)
ϕ_{upload}	=	resistance factor for shafts, static uplift load test (dim) (10.5.5.2.4) (10.9.3.5.1)
ϕ_τ	=	resistance factor for sliding resistance between soil and footing (dim) (10.5.5.2.2)

10.4—SOIL AND ROCK PROPERTIES

10.4.1—Informational Needs

The expected project requirements shall be analyzed to determine the type and quantity of information to be developed during the geotechnical exploration. This analysis should consist of the following:

- Identify design and constructability requirements, e.g., provide grade separation, support loads from bridge superstructure, provide for dry excavation, and their effect on the geotechnical information needed.
- Identify performance criteria, e.g., limiting settlements, right of way restrictions, proximity of adjacent structures, and schedule constraints.
- Identify areas of geologic concern on the site and potential variability of local geology.
- Identify areas of hydrologic concern on the site, e.g., potential erosion or scour locations.

C10.4.1

The first phase of an exploration and testing program requires that the Engineer understand the project requirements and the site conditions and/or restrictions. The ultimate goal of this phase is to identify geotechnical data needs for the project and potential methods available to assess these needs.

Geotechnical Engineering Circular #5—Evaluation of Soil and Rock Properties (Sabatini et al., 2002) provides a summary of information needs and testing considerations for various geotechnical applications.

- Develop likely sequence and phases of construction and their effect on the geotechnical information needed.
- Identify engineering analyses to be performed, e.g., bearing capacity, settlement, global stability.
- Identify engineering properties and parameters required for these analyses.
- Determine methods to obtain parameters and assess the validity of such methods for the material type and construction methods.
- Determine the number of tests/samples needed and appropriate locations for them.

10.4.2—Subsurface Exploration

Subsurface explorations shall be performed to provide the information needed for the design and construction of foundations. The extent of exploration shall be based on variability in the subsurface conditions, structure type, and any project requirements that may affect the foundation design or construction. The exploration program should be extensive enough to reveal the nature and types of soil deposits and/or rock formations encountered, the engineering properties of the soils and/or rocks, the potential for liquefaction, and the groundwater conditions. The exploration program should be sufficient to identify and delineate problematic subsurface conditions such as karstic formations, mined out areas, swelling/collapsing soils, existing fill or waste areas, etc.

Borings should be sufficient in number and depth to establish a reliable longitudinal and transverse substrata profile at areas of concern such as at structure foundation locations and adjacent earthwork locations, and to investigate any adjacent geologic hazards that could affect the structure performance.

As a minimum, the subsurface exploration and testing program shall obtain information adequate to analyze foundation stability and settlement with respect to:

- Geological formation(s) present,
- Location and thickness of soil and rock units,
- Engineering properties of soil and rock units, such as unit weight, shear strength and compressibility,
- Groundwater conditions,
- Ground surface topography, and
- Local considerations, e.g., liquefiable, expansive or dispersive soil deposits, underground voids from solution weathering or mining activity, or slope instability potential.

C10.4.2

The performance of a subsurface exploration program is part of the process of obtaining information relevant for the design and construction of substructure elements. The elements of the process that should precede the actual exploration program include a search and review of published and unpublished information at and near the site, a visual site inspection, and design of the subsurface exploration program. Refer to Mayne et al. (2001) and Sabatini et al. (2002) for guidance regarding the planning and conduct of subsurface exploration programs.

The suggested minimum number and depth of borings are provided in Table 10.4.2-1. While engineering judgment will need to be applied by a licensed and experienced geotechnical professional to adapt the exploration program to the foundation types and depths needed and to the variability in the subsurface conditions observed, the intent of Table 10.4.2-1 regarding the minimum level of exploration needed should be carried out. The depth of borings indicated in Table 10.4.2-1 performed before or during design should take into account the potential for changes in the type, size and depth of the planned foundation elements.

This Table should be used only as a first step in estimating the number of borings for a particular design, as actual boring spacings will depend upon the project type and geologic environment. In areas underlain by heterogeneous soil deposits and/or rock formations, it will probably be necessary to drill more frequently and/or deeper than the minimum guidelines in Table 10.4.2-1 to capture variations in soil and/or rock type and to assess consistency across the site area. For situations where large diameter rock socketed shafts will be used or where drilled shafts are being installed in formations known to have large boulders, or voids such as in karstic or mined areas, it may be necessary to advance a boring at the location of each shaft. Even the best and most detailed subsurface exploration programs may not identify every important subsurface problem condition if conditions are highly variable. The goal of the subsurface exploration program, however, is to reduce the risk of such problems to an acceptable minimum.

Table 10.4.2-1 shall be used as a starting point for determining the locations of borings. The final exploration program should be adjusted based on the variability of the anticipated subsurface conditions as well as the variability observed during the exploration program. If conditions are determined to be variable, the exploration program should be increased relative to the requirements in Table 10.4.2-1 such that the objective of establishing a reliable longitudinal and transverse substrata profile is achieved. If conditions are observed to be homogeneous or otherwise are likely to have minimal impact on the foundation performance, and previous local geotechnical and construction experience has indicated that subsurface conditions are homogeneous or otherwise are likely to have minimal impact on the foundation performance, a reduced exploration program relative to what is specified in Table 10.4.2-1 may be considered.

If requested by the Owner or as required by law, boring and penetration test holes shall be plugged.

Laboratory and/or in-situ tests shall be performed to determine the strength, deformation, and permeability characteristics of soils and/or rocks and their suitability for the foundation proposed.

In a laterally homogeneous area, drilling or advancing a large number of borings may be redundant, since each sample tested would exhibit similar engineering properties. Furthermore, in areas where soil or rock conditions are known to be very favorable to the construction and performance of the foundation type likely to be used, e.g., footings on very dense soil, and groundwater is deep enough to not be a factor, obtaining fewer borings than provided in Table 10.4.2-1 may be justified. In all cases, it is necessary to understand how the design and construction of the geotechnical feature will be affected by the soil and/or rock mass conditions in order to optimize the exploration.

Borings may need to be plugged due to requirements by regulatory agencies having jurisdiction and/or to prevent water contamination and/or surface hazards.

Parameters derived from field tests, e.g., driven pile resistance based on cone penetrometer testing, may also be used directly in design calculations based on empirical relationships. These are sometimes found to be more reliable than analytical calculations, especially in familiar ground conditions for which the empirical relationships are well established.

Table 10.4.2-1—Minimum Number of Exploration Points and Depth of Exploration (modified after Sabatini et al., 2002)

Application	Minimum Number of Exploration Points and Location of Exploration Points	Minimum Depth of Exploration
Retaining Walls	A minimum of one exploration point for each retaining wall. For retaining walls more than 100 ft in length, exploration points spaced every 100 to 200 ft with locations alternating from in front of the wall to behind the wall. For anchored walls, additional exploration points in the anchorage zone spaced at 100 to 200 ft. For soil-nailed walls, additional exploration points at a distance of 1.0 to 1.5 times the height of the wall behind the wall spaced at 100 to 200 ft.	Investigate to a depth below bottom of wall at least to a depth where stress increase due to estimated foundation load is less than ten percent of the existing effective overburden stress at that depth and between one and two times the wall height. Exploration depth should be great enough to fully penetrate soft highly compressible soils, e.g., peat, organic silt, or soft fine grained soils, into competent material of suitable bearing capacity, e.g., stiff to hard cohesive soil, compact dense cohesionless soil, or bedrock.
Shallow Foundations	For substructure, e.g., piers or abutments, widths less than or equal to 100 ft, a minimum of one exploration point per substructure. For substructure widths greater than 100 ft, a minimum of two exploration points per substructure. Additional exploration points should be provided if erratic subsurface conditions are encountered.	<p>Depth of exploration should be:</p> <ul style="list-style-type: none"> • great enough to fully penetrate unsuitable foundation soils, e.g., peat, organic silt, or soft fine grained soils, into competent material of suitable bearing resistance, e.g., stiff to hard cohesive soil, or compact to dense cohesionless soil or bedrock ; • at least to a depth where stress increase due to estimated foundation load is less than ten percent of the existing effective overburden stress at that depth; and • if bedrock is encountered before the depth required by the second criterion above is achieved, exploration depth should be great enough to penetrate a minimum of 10 ft into the bedrock, but rock exploration should be sufficient to characterize compressibility of infill material of near-horizontal to horizontal discontinuities. <p>Note that for highly variable bedrock conditions, or in areas where very large boulders are likely, more than 10 ft or rock core may be required to verify that adequate quality bedrock is present.</p>
Deep Foundations	For substructure, e.g., bridge piers or abutments, widths less than or equal to 100 ft, a minimum of one exploration point per substructure. For substructure widths greater than 100 ft, a minimum of two exploration points per substructure. Additional exploration points should be provided if erratic subsurface conditions are encountered, especially for the case of shafts socketed into bedrock.	<p>In soil, depth of exploration should extend below the anticipated pile or shaft tip elevation a minimum of 20 ft, or a minimum of two times the maximum pile group dimension, whichever is deeper. All borings should extend through unsuitable strata such as unconsolidated fill, peat, highly organic materials, soft fine-grained soils, and loose coarse-grained soils to reach hard or dense materials.</p> <p>For piles bearing on rock, a minimum of 10 ft of rock core shall be obtained at each exploration point location to verify that the boring has not terminated on a boulder.</p> <p>For shafts supported on or extending into rock, a minimum of 10 ft of rock core, or a length of rock core equal to at least three times the shaft diameter for isolated shafts or two times the maximum shaft group dimension, whichever is greater, shall be extended below the anticipated shaft tip elevation to determine the physical characteristics of rock within the zone of foundation influence.</p> <p>Note that for highly variable bedrock conditions, or in areas where very large boulders are likely, more than 10 ft or rock core may be required to verify that adequate quality bedrock is present.</p>

10.4.3—Laboratory Tests

10.4.3.1—Soil Tests

Laboratory testing should be conducted to provide the basic data with which to classify soils and to measure their engineering properties.

When performed, laboratory tests shall be conducted in accordance with the AASHTO, ASTM, or Owner-supplied procedures applicable to the design properties needed.

10.4.3.2—Rock Tests

If laboratory strength tests are conducted on intact rock samples for classification purposes, they should be considered as upper bound values. If laboratory compressibility tests are conducted, they should be considered as lower bound values. Additionally, laboratory tests should be used in conjunction with field tests and field characterization of the rock mass to give estimates of rock mass behavioral characteristics. When performed, laboratory tests shall be conducted in accordance with the ASTM or Owner-supplied procedures applicable to the design properties needed.

10.4.4—In-Situ Tests

In-situ tests may be performed to obtain deformation and strength parameters of foundation soils or rock for the purposes of design and/or analysis. In-situ tests should be conducted in soils that do not lend themselves to undisturbed sampling as a means to estimate soil design parameters. When performed, in-situ tests shall be conducted in accordance with the appropriate ASTM or AASHTO standards.

Where in-situ test results are used to estimate design properties through correlations, such correlations should be well established through long-term widespread use or through detailed measurements that illustrate the accuracy of the correlation.

C10.4.3.1

Laboratory tests of soils may be grouped broadly into two general classes:

- Classification or index tests. These may be performed on either disturbed or undisturbed samples.
- Quantitative or performance tests for permeability, compressibility and shear strength. These tests are generally performed on undisturbed samples, except for materials to be placed as controlled fill or materials that do not have a stable soil-structure, e.g., cohesionless materials. In these cases, tests should be performed on specimens prepared in the laboratory.

Detailed information regarding the types of tests needed for foundation design is provided in Geotechnical Engineering Circular #5—Evaluation of Soil and Rock Properties (Sabatini et al., 2002).

C10.4.3.2

Rock samples small enough to be tested in the laboratory are usually not representative of the entire rock mass. Laboratory testing of rock is used primarily for classification of intact rock samples, and, if performed properly, serves a useful function in this regard.

Detailed information regarding the types of tests needed and their use for foundation design is provided in Geotechnical Engineering Circular #5—Evaluation of Soil and Rock Properties, April 2002 (Sabatini et al., 2002).

C10.4.4

Detailed information on in-situ testing of soils and rock and their application to geotechnical design can be found in Sabatini et al. (2002) and Wyllie (1999).

Correlations are in some cases specific to a geological formation. While this fact does not preclude the correlation from being useful in other geologic formations, the applicability of the correlation to those other formations should be evaluated.

For further discussion, see Article 10.4.6.

10.4.5—Geophysical Tests

Geophysical testing should be used only in combination with information from direct methods of exploration, such as *SPT*, *CPT*, etc. to establish stratification of the subsurface materials, the profile of the top of bedrock and bedrock quality, depth to groundwater, limits of types of soil deposits, the presence of voids, anomalous deposits, buried pipes, and depths of existing foundations. Geophysical tests shall be selected and conducted in accordance with available ASTM standards. For those cases where ASTM standards are not available, other widely accepted detailed guidelines, such as Sabatini et al. (2002), AASHTO *Manual on Subsurface Investigations* (1988), Arman et al. (1997) and Campanella (1994), should be used.

C10.4.5

Geophysical testing offers some notable advantages and some disadvantages that should be considered before the technique is recommended for a specific application. The advantages are summarized as follows:

- Many geophysical tests are noninvasive and thus, offer, significant benefits in cases where conventional drilling, testing and sampling are difficult, e.g., deposits of gravel, talus deposits, or where potentially contaminated subsurface soils may occur.
- In general, geophysical testing covers a relatively large area, thus providing the opportunity to generally characterize large areas in order to optimize the locations and types of in-situ testing and sampling. Geophysical methods are particularly well suited to projects that have large longitudinal extent compared to lateral extent, e.g., new highway construction.
- Geophysical measurement assesses the characteristics of soil and rock at very small strains, typically on the order of 0.001 percent, thus providing information on truly elastic properties, which are used to evaluate service limit states.
- For the purpose of obtaining subsurface information, geophysical methods are relatively inexpensive when considering cost relative to the large areas over which information can be obtained.

Some of the disadvantages of geophysical methods include:

- Most methods work best for situations in which there is a large difference in stiffness or conductivity between adjacent subsurface units.
- It is difficult to develop good stratigraphic profiling if the general stratigraphy consists of hard material over soft material or resistive material over conductive material.
- Results are generally interpreted qualitatively and, therefore, only an experienced engineer or geologist familiar with the particular testing method can obtain useful results.
- Specialized equipment is required (compared to more conventional subsurface exploration tools).
- Since evaluation is performed at very low strains, or no strain at all, information regarding ultimate strength for evaluation of strength limit states is only obtained by correlation.

There are a number of different geophysical in-situ tests that can be used for stratigraphic information and determination of engineering properties. These methods can be combined with each other and/or combined with the in-situ tests presented in Article 10.4.4 to provide additional resolution and accuracy. ASTM D6429, Standard Guide for Selecting Surface Geophysical Methods, provides additional guidance on selection of suitable methods.

10.4.6—Selection of Design Properties

10.4.6.1—General

Subsurface soil or rock properties shall be determined using one or more of the following methods:

- In-situ testing during the field exploration program, including consideration of any geophysical testing conducted,
- Laboratory testing, and
- Back analysis of design parameters based on site performance data.

Local experience, local geologic formation specific property correlations, and knowledge of local geology, in addition to broader based experience and relevant published data, should also be considered in the final selection of design parameters. If published correlations are used in combination with one of the methods listed above, the applicability of the correlation to the specific geologic formation shall be considered through the use of local experience, local test results, and/or long-term experience.

The focus of geotechnical design property assessment and final selection shall be on the individual geologic strata identified at the project site.

The design values selected for the parameters should be appropriate to the particular limit state and its correspondent calculation model under consideration.

The determination of design parameters for rock shall take into consideration that rock mass properties are generally controlled by the discontinuities within the rock mass and not the properties of the intact material. Therefore, engineering properties for rock should account for the properties of the intact pieces and for the properties of the rock mass as a whole, specifically considering the discontinuities within the rock mass. A combination of laboratory testing of small samples, empirical analysis, and field observations should be employed to determine the engineering properties of rock masses, with greater emphasis placed on visual observations and quantitative descriptions of the rock mass.

C10.4.6.1

A geologic stratum is characterized as having the same geologic depositional history and stress history, and generally has similarities throughout the stratum in terms of density, source material, stress history, and hydrogeology. The properties of a given geologic stratum at a project site are likely to vary significantly from point to point within the stratum. In some cases, a measured property value may be closer in magnitude to the measured property value in an adjacent geologic stratum than to the measured properties at another point within the same stratum. However, soil and rock properties for design should not be averaged across multiple strata.

It should also be recognized that some properties, e.g., undrained shear strength in normally consolidated clays, may vary as a predictable function of a stratum dimension, e.g., depth below the top of the stratum. Where the property within the stratum varies in this manner, the design parameters should be developed taking this variation into account, which may result in multiple values of the property within the stratum as a function of a stratum dimension such as depth.

The observational method, or use of back analysis, to determine engineering properties of soil or rock is often used with slope failures, embankment settlement or excessive settlement of existing structures. With landslides or slope failures, the process generally starts with determining the geometry of the failure and then determining the soil/rock parameters or subsurface conditions that result from a combination of load and resistance factors that approach 1.0. Often the determination of the properties is aided by correlations with index tests or experience on other projects. For embankment settlement, a range of soil properties is generally determined based on laboratory performance testing on undisturbed samples. Monitoring of fill settlement and pore pressure in the soil during construction allows the soil properties and prediction of the rate of future settlement to be refined. For structures such as bridges that experience unacceptable settlement or retaining walls that have excessive deflection, the engineering properties of the soils can sometimes be determined if the magnitudes of the loads are known. As with slope stability analysis, the subsurface stratigraphy must be adequately known, including the history of the groundwater level at the site.

Local geologic formation-specific correlations may be used if well established by data comparing the prediction from the correlation to measured high quality laboratory performance data, or back-analysis from full scale performance of geotechnical elements affected by the geologic formation in question.

The Engineer should assess the variability of relevant data to determine if the observed variability is a result of inherent variability of subsurface materials and testing methods or if the variability is a result of significant variations across the site. Methods to compare soil parameter variability for a particular project to published values of variability based on database information of common soil parameters are presented in Sabatini (2002) and Duncan (2000). Where the variability is deemed to exceed the inherent variability of the material and testing methods, or where sufficient relevant data is not available to determine an average value and variability, the Engineer may perform a sensitivity analysis using average parameters and a parameter reduced by one standard deviation, i.e., “mean minus 1 sigma,” or a lower bound value. By conducting analyses at these two potential values, an assessment is made of the sensitivity of the analysis results to a range of potential design values. If these analyses indicate that acceptable results are provided and that the analyses are not particularly sensitive to the selected parameters, the Engineer may be comfortable with concluding the analyses. If, on the other hand, the Engineer determines that the calculation results are marginal or that the results are sensitive to the selected parameter, additional data collection/review and parameter selection are warranted.

When evaluating service limit states, it is often appropriate to determine both upper and lower bound values from the relevant data, since the difference in displacement of substructure units is often more critical to overall performance than the actual value of the displacement for the individual substructure unit.

For strength limit states, average measured values of relevant laboratory test data and/or in-situ test data were used to calibrate the resistance factors provided in Article 10.5, at least for those resistance factors developed using reliability theory, rather than a lower bound value. It should be recognized that to be consistent with how the resistance factors presented in Article 10.5.5.2 were calibrated, i.e., to average property values, accounting for the typical variability in the property, average property values for a given geologic unit should be selected. However, depending on the availability of soil or rock property data and the variability of the geologic strata under consideration, it may not be possible to reliably estimate the average value of the properties needed for design. In such cases, the Engineer may have no choice but to use a more conservative selection of design parameters to mitigate the additional risks created by potential variability or the paucity of relevant data.

Note that for those resistance factors that were determined based on calibration by fitting to allowable stress design, this property selection issue is not relevant, and property selection should be based on past practice.

10.4.6.2—Soil Strength

10.4.6.2.1—General

The selection of soil shear strength for design should consider, at a minimum, the following:

- the rate of construction loading relative to the hydraulic conductivity of the soil, i.e., drained or undrained strengths;
- the effect of applied load direction on the measured shear strengths during testing;
- the effect of expected levels of deformation for the geotechnical structure; and
- the effect of the construction sequence.

10.4.6.2.2—Undrained Strength of Cohesive Soils

Where possible, laboratory consolidated undrained (CU) and unconsolidated undrained (UU) testing should be used to estimate the undrained shear strength, S_u , supplemented as needed with values determined from in-situ testing. Where collection of undisturbed samples for laboratory testing is difficult, values obtained from in-situ testing methods may be used. For relatively thick deposits of cohesive soil, profiles of S_u as a function of depth should be obtained so that the deposit stress history and properties can be ascertained.

C10.4.6.2.1

Refer to Sabatini et al. (2002) for additional guidance on determining which soil strength parameters are appropriate for evaluating a particular soil type and loading condition. In general, where loading is rapid enough and/or the hydraulic conductivity of the soil is low enough such that excess pore pressure induced by the loading does not dissipate, undrained (total) stress parameters should be used. Where loading is slow enough and/or the hydraulic conductivity of the soil is great enough such that excess pore pressures induced by the applied load dissipate as the load is applied, drained (effective) soil parameters should be used. Drained (effective) soil parameters should also be used to evaluate long term conditions where excess pore pressures have been allowed to dissipate or where the designer has explicit knowledge of the expected magnitude and distribution of the excess pore pressure.

C10.4.6.2.2

For design analyses of short-term conditions in normally to lightly overconsolidated cohesive soils, the undrained shear strength, S_u , is commonly evaluated. Since undrained strength is not a unique property, profiles of undrained strength developed using different testing methods will vary. Typical transportation project practice entails determination of S_u based on laboratory CU and UU testing and, for cases where undisturbed sampling is very difficult, field vane testing. Other in-situ methods can also be used to estimate the value of S_u .

Specific issues that should be considered when estimating the undrained shear strength are described below:

- Strength measurements from hand torvanes, pocket penetrometers, or unconfined compression tests should not be solely used to evaluate undrained shear strength for design analyses. Consolidated undrained (CU) triaxial tests and in-situ tests should be used.

- For relatively deep deposits of cohesive soil, e.g., approximately 20 ft depth or more, all available undrained strength data should be plotted with depth. The type of test used to evaluate each undrained strength value should be clearly identified. Known soil layering should be used so that trends in undrained strength data can be developed for each soil layer.
- Review data summaries for each laboratory strength test method. Moisture contents of specimens for strength testing should be compared to moisture contents of other samples at similar depths. Significant changes in moisture content will affect measured undrained strengths. Review boring logs, Atterberg limits, grain size, and unit weight measurements to confirm soil layering.
- CU tests on normally to slightly over consolidated samples that exhibit disturbance should contain at least one specimen consolidated to at least $4\sigma_p'$ to permit extrapolation of the undrained shear strength at σ_p' .
- Undrained strengths from CU tests correspond to the effective consolidation pressure used in the test. This effective stress needs to be converted to the equivalent depth in the ground.
- A profile of σ_p' (or OCR) should be developed and used in evaluating undrained shear strength.
- Correlations for S_u based on in-situ test measurements should not be used for final design unless they have been calibrated to the specific soil profile under consideration. Correlations for S_u based on *SPT* tests should be avoided.

10.4.6.2.3—Drained Strength of Cohesive Soils

Long-term effective stress strength parameters, c' and ϕ'_f , of clays should be evaluated by slow consolidated drained direct shear box tests, consolidated drained (CD) triaxial tests, or consolidated undrained (CU) triaxial tests with pore pressure measurements. In laboratory tests, the rate of shearing should be sufficiently slow to ensure substantially complete dissipation of excess pore pressure in the drained tests or, in undrained tests, complete equalization of pore pressure throughout the specimen.

10.4.6.2.4—Drained Strength of Granular Soils

The drained friction angle of granular deposits should be evaluated by correlation to the results of *SPT* testing, *CPT* testing, or other relevant in-situ tests. Laboratory shear strength tests on undisturbed samples, if feasible to obtain, or reconstituted disturbed samples, may also be used to determine the shear strength of granular soils.

C10.4.6.2.3

The selection of peak, fully softened, or residual strength for design analyses should be based on a review of the expected or tolerable displacements of the soil mass.

The use of a nonzero cohesion intercept (c') for long-term analyses in natural materials must be carefully assessed. With continuing displacements, it is likely that the cohesion intercept value will decrease to zero for long-term conditions, especially for highly plastic clays.

C10.4.6.2.4

Because obtaining undisturbed samples of granular deposits for laboratory testing is extremely difficult, the results of in-situ tests are commonly used to develop estimates of the drained friction angle, ϕ_f . If reconstituted disturbed soil samples and laboratory tests are used to estimate the drained friction angle, the reconstituted samples should be compacted to the same

If *SPT N* values are used, unless otherwise specified for the design method or correlation being used, they shall be corrected for the effects of overburden pressure determined as:

$$N_1 = C_N N \quad (10.4.6.2.4-1)$$

N_1 = *SPT* blow count corrected for overburden pressure, σ'_v (blows/ft)

$$C_N = [0.77 \log_{10}(40/\sigma'_v)], \text{ and } C_N < 2.0$$

σ'_v = vertical effective stress (ksf)

N = uncorrected *SPT* blow count (blows/ft)

SPT N values should also be corrected for hammer efficiency, if applicable to the design method or correlation being used, determined as:

$$N_{60} = (ER / 60\%) N \quad (10.4.6.2.4-2)$$

where:

N_{60} = *SPT* blow count corrected for hammer efficiency (blows/ft)

ER = hammer efficiency expressed as percent of theoretical free fall energy delivered by the hammer system actually used

N = uncorrected *SPT* blow count (blows/ft)

When *SPT* blow counts have been corrected for both overburden effects and hammer efficiency effects, the resulting corrected blow count shall be denoted as N_{160} , determined as:

$$N_{160} = C_N N_{60} \quad (10.4.6.2.4-3)$$

The drained friction angle of granular deposits should be determined based on the following correlation.

Table 10.4.6.2.4-1—Correlation of *SPT N*₆₀ Values to Drained Friction Angle of Granular Soils (modified after Bowles, 1977)

N_{160}	ϕ_f
<4	25–30
4	27–32
10	30–35
30	35–40
50	38–43

relative density estimated from the available in-situ data. The test specimen should be large enough to allow the full grain size range of the soil to be included in the specimen. This may not always be possible, and if not possible, it should be recognized that the shear strength measured would likely be conservative.

A method using the results of *SPT* testing is presented. Other in-situ tests such as *CPT* and *DMT* may be used. For details on determination of ϕ_f from these tests, refer to Sabatini et al. (2002).

The use of automatic trip hammers is increasing. In order to use correlations based on standard rope and cathead hammers, the *SPT N* values must be corrected to reflect the greater energy delivered to the sampler by these systems.

Hammer efficiency (ER) for specific hammer systems used in local practice may be used in lieu of the values provided. If used, specific hammer system efficiencies shall be developed in general accordance with ASTM D4945 for dynamic analysis of driven piles or other accepted procedure.

The following values for ER may be assumed if hammer specific data are not available, e.g., from older boring logs:

ER = 60 percent for conventional drop hammer using rope and cathead

ER = 80 percent for automatic trip hammer

Corrections for rod length, hole size, and use of a liner may also be made if appropriate. In general, these are only significant in unusual cases or where there is significant variation from standard procedures. These corrections may be significant for evaluation of liquefaction. Information on these additional corrections may be found in Youd and Idriss (1997).

The N_{160} - ϕ_f correlation used is modified after Bowles (1977). The correlation of Peck, Hanson, and Thornburn (1974) falls within the ranges specified. Experience should be used to select specific values within the ranges. In general, finer materials or materials with significant silt-sized material will fall in the lower portion of the range. Coarser materials with less than five percent fines will fall in the upper portion of the ranges. The geologic history and angularity of the particles may also need to be considered when selecting a value for ϕ_f .

Care should be exercised when using other correlations of *SPT* results to soil parameters. Some published correlations are based on corrected values

For gravels and rock fill materials where *SPT* testing is not reliable, Figure 10.4.6.2.4-1 should be used to estimate the drained friction angle.

Rock Fill Grade	Particle Unconfined Compressive Strength (ksf)
A	>4610
B	3460– 4610
C	2590– 3460
D	1730– 2590
E	≤1730

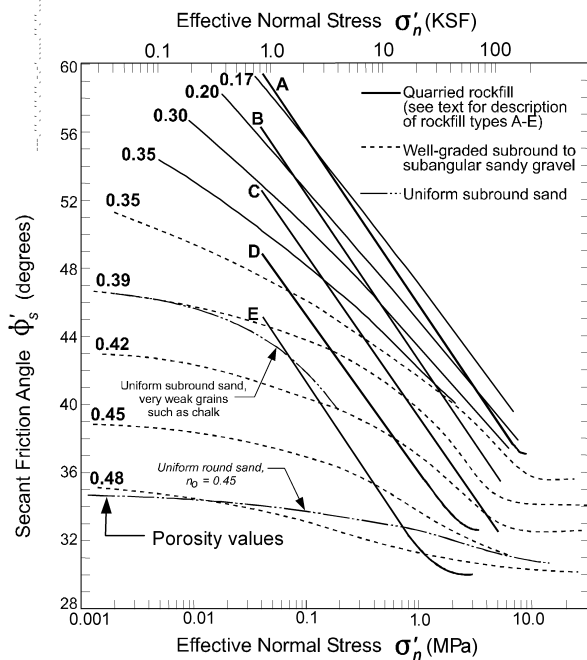

Figure 10.4.6.2.4-1—Estimation of Drained Friction Angle of Gravels and Rock Fills (modified after Terzaghi, Peck, and Mesri, 1996)

10.4.6.3—Soil Deformation

Consolidation parameters C_c , C_r , C_a should be determined from the results of one-dimensional consolidation tests. To assess the potential variability in the settlement estimate, the average, upper and lower bound values obtained from testing should be considered.

(M_{60}) and some are based on uncorrected values (N). The designer should ascertain the basis of the correlation and use either M_{60} or N as appropriate.

Care should also be exercised when using *SPT* blow counts to estimate soil shear strength if in soils with coarse gravel, cobbles, or boulders. Large gravels, cobbles, or boulders could cause the *SPT* blow counts to be unrealistically high.

The secant friction angle derived from the procedure to estimate the drained friction angle of gravels and rock fill materials depicted in Figure 10.4.6.2.4-1 is based on a straight line from the origin of a Mohr diagram to the intersection with the strength envelope at the effective normal stress. Thus the angle derived is applicable only to analysis of field conditions subject to similar normal stresses. See Terzaghi, Peck, and Mesri (1996) for additional details regarding this procedure.

C10.4.6.3

It is important to understand whether the values obtained are computed based on a void ratio definition or a strain definition. Computational methods vary for each definition.

For preliminary analyses or where accurate prediction of settlement is not critical, values obtained

Preconsolidation stress may be determined from one-dimensional consolidation tests and in-situ tests. Knowledge of the stress history of the soil should be used to supplement data from laboratory and/or in-situ tests, if available.

The coefficient of consolidation, c_v , should be determined from the results of one-dimensional consolidation tests. The variability in laboratory determination of c_v results should be considered in the final selection of the value of c_v to be used for design.

Where evaluation of elastic settlement is critical to the design of the foundation or selection of the foundation type, in-situ methods such as PMT or DMT for evaluating the modulus of the stratum should be used.

from correlations to index properties may be used. Refer to Sabatini et al. (2002) for discussion of the various correlations available. If correlations for prediction of settlement are used, their applicability to the specific geologic formation under consideration should be evaluated.

A profile of σ_p' , or $OCR = \sigma_p'/\sigma_o'$, with depth should be developed for the site for design applications where the stress history could have a significant impact on the design properties selected and the performance of the foundation. As with consolidation properties, an upper and lower bound profile should be developed based on laboratory tests and plotted with a profile based on particular in-situ test(s), if used. It is particularly important to accurately compute preconsolidation stress values for relatively shallow depths where in-situ effective stresses are low. An underestimation of the preconsolidation stress at shallow depths will result in overly conservative estimates of settlement for shallow soil layers.

Due to the numerous simplifying assumptions associated with conventional consolidation theory, on which the coefficient of consolidation is based, it is unlikely that even the best estimates of c_v from high-quality laboratory tests will result in predictions of time rate of settlement in the field that are significantly better than a prediction within one order of magnitude. In general, the in-situ value of c_v is larger than the value measured in the laboratory test. Therefore, a rational approach is to select average, upper, and lower bound values for the appropriate stress range of concern for the design application. These values should be compared to values obtained from previous work performed in the same soil deposit. Under the best-case conditions, these values should be compared to values computed from measurements of excess pore pressures or settlement rates during construction of other structures.

CPTu tests in which the pore pressure dissipation rate is measured may be used to estimate the field coefficient of consolidation.

For preliminary analyses or where accurate prediction of settlement is not critical, values obtained from correlations to index properties presented in Sabatini et al. (2002) may be used.

For preliminary design or for final design where the prediction of deformation is not critical to structure performance, i.e., the structure design can tolerate the potential inaccuracies inherent in the correlations. The elastic properties (E_s , ν) of a soil may be estimated from empirical relationships presented in Table C10.4.6.3-1.

The specific definition of E_s is not always consistent for the various correlations and methods of in-situ measurement. See Sabatini et al. (2002) for additional details regarding the definition and determination of E_s .

An alternative method of evaluating the equivalent elastic modulus using measured shear wave velocities is presented in Sabatini et al. (2002).

Table C10.4.6.3-1—Elastic Constants of Various Soils (modified after U.S. Department of the Navy, 1982; Bowles, 1988)

Soil Type	Typical Range of Young's Modulus Values, E_s (ksi)	Poisson's Ratio, ν (dim)
Clay: Soft sensitive Medium stiff to stiff Very stiff	0.347–2.08 2.08–6.94 6.94–13.89	0.4–0.5 (undrained)
Loess	2.08–8.33	0.1–0.3
Silt	0.278–2.78	0.3–0.35
Fine Sand: Loose Medium dense Dense	1.11–1.67 1.67–2.78 2.78–4.17	0.25
Sand: Loose Medium dense Dense	1.39–4.17 4.17–6.94 6.94–11.11	0.20–0.36 0.30–0.40
Gravel: Loose Medium dense Dense	4.17–11.11 11.11–13.89 13.89–27.78	0.20–0.35 0.30–0.40
Estimating E_s from $SPT N$ Value		
Soil Type	E_s (ksi)	
Silts, sandy silts, slightly cohesive mixtures	$0.056 N_{160}$	
Clean fine to medium sands and slightly silty sands	$0.097 N_{160}$	
Coarse sands and sands with little gravel	$0.139 N_{160}$	
Sandy gravel and gravels	$0.167 N_{160}$	
Estimating E_s from q_c (static cone resistance)		
Sandy soils	$0.028q_c$	

The modulus of elasticity for normally consolidated granular soils tends to increase with depth. An alternative method of defining the soil modulus for granular soils is to assume that it increases linearly with depth starting at zero at the ground surface in accordance with the following equation:

$$E_s = n_h \times z \quad (\text{C10.4.6.3-1})$$

where:

- E_s = the soil modulus at depth z (ksi)
 n_h = rate of increase of soil modulus with depth as defined in Table C10.4.6.3-2 (ksi/ft)
 z = depth below the ground surface (ft)

Table C10.4.6.3-2—Rate of Increase of Soil Modulus with Depth n_h (ksi/ft) for Sand

Consistency	Dry or Moist	Submerged
Loose	0.417	0.208
Medium	1.11	0.556
Dense	2.78	1.39

The potential for soil swell that may result in uplift on deep foundations or heave of shallow foundations should be evaluated based on Table 10.4.6.3-1.

Table 10.4.6.3-1—Method for Identifying Potentially Expansive Soils (Reese and O'Neill, 1988)

Liquid Limit <i>LL</i> (%)	Plastic Limit <i>PL</i> (%)	Soil Suction (ksf)	Potential Swell (%)	Potential Swell Classifi- cation
>60	>35	>8	>1.5	High
50–60	25–35	3–8	0.5–1.5	Marginal
<50	<25	<3	<0.5	Low

10.4.6.4—Rock Mass Strength

The strength of intact rock material should be determined using the results of unconfined compression tests on intact rock cores, splitting tensile tests on intact rock cores, or point load strength tests on intact specimens of rock.

The rock should be classified using the rock mass rating system (RMR) as described in Table 10.4.6.4-1. For each of the five parameters in the Table, the relative rating based on the ranges of values provided should be evaluated. The rock mass rating (RMR) should be determined as the sum of all five relative ratings. The RMR should be adjusted in accordance with the criteria in Table 10.4.6.4-2. The rock classification should be determined in accordance with Table 10.4.6.4-3.

C10.4.6.4

Because of the importance of the discontinuities in rock, and the fact that most rock is much more discontinuous than soil, emphasis is placed on visual assessment of the rock and the rock mass.

Other methods for assessing rock mass strength, including in-situ tests or other visual systems that have proven to yield accurate results may be used in lieu of the specified method.

Table 10.4.6.4-1—Geomechanics Classification of Rock Masses

Parameter		Ranges of Values							
1	Strength of intact rock material	Point load strength index	>175 ksf	85–175 ksf	45–85 ksf	20–45 ksf	For this low range, uniaxial compressive test is preferred		
		Uniaxial compressive strength	>4320 ksf	2160–4320 ksf	1080–2160 ksf	520–1080 ksf	215–520 ksf	70–215 ksf	20–70 ksf
	Relative Rating	15	12	7	4	2	1	0	
2	Drill core quality RQD	90% to 100%	75% to 90%	50% to 75%	25% to 50%	<25%			
	Relative Rating	20	17	13	8	3			
3	Spacing of joints	>10 ft	3–10 ft	1–3 ft	2 in.–1 ft	<2 in.			
	Relative Rating	30	25	20	10	5			
4	Condition of joints	<ul style="list-style-type: none"> • Very rough surfaces • Not continuous • No separation • Hard joint wall rock 	<ul style="list-style-type: none"> • Slightly rough surfaces • Separation <0.05 in. • Hard joint wall rock 	<ul style="list-style-type: none"> • Slightly rough surfaces • Separation <0.05 in. • Soft joint wall rock 	<ul style="list-style-type: none"> • Slicken-sided surfaces or • Gouge <0.2 in. thick or • Joints open 0.05–0.2 in. • Continuous joints 	<ul style="list-style-type: none"> • Soft gouge >0.2 in. thick or • Joints open >0.2 in. • Continuous joints 			
	Relative Rating	25	20	12	6	0			
5	Groundwater conditions (use one of the three evaluation criteria as appropriate to the method of exploration)	Inflow per 30 ft tunnel length	None	<400 gal./hr.	400–2000 gal./hr.	>2000 gal./hr.			
		Ratio = joint water pressure/major principal stress	0	0.0–0.2	0.2–0.5	>0.5			
	General Conditions	Completely Dry	Moist only (interstitial water)	Water under moderate pressure	Severe water problems				
	Relative Rating	10	7	4	0				

Table 10.4.6.4-2—Geomechanics Rating Adjustment for Joint Orientations

Strike and Dip Orientations of Joints		Very Favorable	Favorable	Fair	Unfavorable	Very Unfavorable
Ratings	Tunnels	0	-2	-5	-10	-12
	Foundations	0	-2	-7	-15	-25
	Slopes	0	-5	-25	-50	-60

Table 10.4.6.4-3—Geomechanics Rock Mass Classes Determined from Total Ratings

RMR Rating	100–81	80–61	60–41	40–21	<20
Class No.	I	II	III	IV	V
Description	Very good rock	Good rock	Fair rock	Poor rock	Very poor rock

The shear strength of fractured rock masses should be evaluated using the Hoek and Brown criteria, in which the shear strength is represented as a curved envelope that is a function of the uniaxial compressive strength of the intact rock, q_u , and two dimensionless constants m and s . The values of m and s as defined in Table 10.4.6.4-4 should be used.

The shear strength of the rock mass should be determined as:

$$\tau = (\cot \phi'_i - \cos \phi'_i) m \frac{q_u}{8} \quad (10.4.6.4-1)$$

in which:

$$\phi'_i = \tan^{-1} \left\{ 4h \cos^2 \left[30 + 0.33 \sin^{-1} \left(\frac{-3}{h^2} \right) \right] - 1 \right\}^{-1/2}$$

$$h = 1 + \frac{16(m\sigma'_n + sq_u)}{(3m^2 q_u)}$$

where:

- τ = the shear strength of the rock mass (ksf)
- ϕ'_i = the instantaneous friction angle of the rock mass (degrees)
- q_u = average unconfined compressive strength of rock core (ksf)
- σ'_n = effective normal stress (ksf)
- m, s = constants from Table 10.4.6.4-4 (dim)

This method was developed by Hoek (1983) and Hoek and Brown (1988, 1997). Note that the instantaneous cohesion at a discrete value of normal stress can be taken as:

$$c_i = \tau - \sigma'_n \tan \phi'_i \quad (C10.4.6.4-1)$$

The instantaneous cohesion and instantaneous friction angle define a conventional linear Mohr envelope at the normal stress under consideration. For normal stresses significantly different than that used to compute the instantaneous values, the resulting shear strength will be unconservative. If there is considerable variation in the effective normal stress in the zone of concern, consideration should be given to subdividing the zone into areas where the normal stress is relative constant and assigning separate strength parameters to each zone. Alternatively, the methods of Hoek (1983) may be used to compute average values for the range of normal stresses expected.

Table 10.4.6.4-4—Approximate Relationship between Rock-Mass Quality and Material Constants Used in Defining Nonlinear Strength (Hoek and Brown, 1988)

Rock Quality	Constants	Rock Type				
		A = Carbonate rocks with well developed crystal cleavage— <i>dolomite, limestone and marble</i> B = Lithified argillaceous rocks— <i>mudstone, siltstone, shale and slate (normal to cleavage)</i> C = Arenaceous rocks with strong crystals and poorly developed crystal cleavage— <i>sandstone and quartzite</i> D = Fine grained polyminerallic igneous crystalline rocks— <i>andesite, dolerite, diabase and rhyolite</i> E = Coarse grained polyminerallic igneous & metamorphic crystalline rocks— <i>amphibolite, gabbro gneiss, granite, norite, quartz-diorite</i>				
		A	B	C	D	E
INTACT ROCK SAMPLES Laboratory size specimens free from discontinuities. CSIR rating: <i>RMR</i> = 100	<i>m</i>	7.00	10.00	15.00	17.00	25.00
	<i>s</i>	1.00	1.00	1.00	1.00	1.00
VERY GOOD QUALITY ROCK MASS Tightly interlocking undisturbed rock with unweathered joints at 3–10 ft CSIR rating: <i>RMR</i> = 85	<i>m</i>	2.40	3.43	5.14	5.82	8.567
	<i>s</i>	0.082	0.082	0.082	0.082	0.082
GOOD QUALITY ROCK MASS Fresh to slightly weathered rock, slightly disturbed with joints at 3–10 ft CSIR rating: <i>RMR</i> = 65	<i>m</i>	0.575	0.821	1.231	1.395	2.052
	<i>s</i>	0.00293	0.00293	0.00293	0.00293	0.00293
FAIR QUALITY ROCK MASS Several sets of moderately weathered joints spaced at 1–3 ft CSIR rating: <i>RMR</i> = 44	<i>m</i>	0.128	0.183	0.275	0.311	0.458
	<i>s</i>	0.00009	0.00009	0.00009	0.00009	0.00009
POOR QUALITY ROCK MASS Numerous weathered joints at 2 to 12 in.; some gouge. Clean compacted waste rock. CSIR rating: <i>RMR</i> = 23	<i>m</i>	0.029	0.041	0.061	0.069	0.102
	<i>s</i>	3×10^{-6}	3×10^{-6}	3×10^{-6}	3×10^{-6}	3×10^{-6}
VERY POOR QUALITY ROCK MASS Numerous heavily weathered joints spaced <2 in. with gouge. Waste rock with fines. CSIR rating: <i>RMR</i> = 3	<i>m</i>	0.007	0.010	0.015	0.017	0.025
	<i>s</i>	1×10^{-7}	1×10^{-7}	1×10^{-7}	1×10^{-7}	1×10^{-7}

Where it is necessary to evaluate the strength of a single discontinuity or set of discontinuities, the strength along the discontinuity should be determined as follows:

- For smooth discontinuities, the shear strength is represented by a friction angle of the parent rock material. To evaluate the friction angle of this type of discontinuity surface for design, direct shear tests on samples should be performed. Samples should be formed in the laboratory by cutting samples of intact core.
- For rough discontinuities the nonlinear criterion of Barton (1976) should be applied.

The range of typical friction angles provided in Table C10.4.6.4-1 may be used in evaluating measured values of friction angles for smooth joints.

Table C10.4.6.4-1—Typical Ranges of Friction Angles for Smooth Joints in a Variety of Rock Types (modified after Barton, 1976; Jaeger and Cook, 1976)

Rock Class	Friction Angle Range	Typical Rock Types
Low Friction	20–27°	Schists (high mica content), shale, marl
Medium Friction	27–34°	Sandstone, siltstone, chalk, gneiss, slate
High Friction	34–40°	Basalt, granite, limestone, conglomerate

Note: Values assume no infilling and little relative movement between joint faces.

When a major discontinuity with a significant thickness of infilling is to be investigated, the shear strength will be governed by the strength of the infilling material and the past and expected future displacement of the discontinuity. Refer to Sabatini et al. (2002) for detailed procedures to evaluate infilled discontinuities.

10.4.6.5—Rock Mass Deformation

The elastic modulus of a rock mass (E_m) shall be taken as the lesser of the intact modulus of a sample of rock core (E_i) or the modulus determined from one of the following equations:

$$E_m = 145 \left(10^{\frac{RMR-10}{40}} \right) \quad (10.4.6.5-1)$$

where:

E_m = Elastic modulus of the rock mass (ksi)

$E_m \leq E_i$

E_i = Elastic modulus of intact rock (ksi)

RMR = Rock mass rating specified in Article 10.4.6.4.

or

$$E_m = \left(\frac{E_m}{E_i} \right) E_i \quad (10.4.6.5-2)$$

C10.4.6.5

Table 10.4.6.5-1 was developed by O'Neill and Reese (1999) based on a reanalysis of the data presented by Carter and Kulhawy (1988) for the purposes of estimating side resistance of shafts in rock.

Preliminary estimates of the elastic modulus of intact rock may be made from Table C10.4.6.5-1. Note that some of the rock types identified in the Table are not present in the U.S.

It is extremely important to use the elastic modulus of the rock mass for computation of displacements of rock materials under applied loads. Use of the intact modulus will result in unrealistic and unconservative estimates.

where:

E_m = Elastic modulus of the rock mass (ksi)

E_m/E_i = Reduction factor determined from Table 10.4.6.5-1 (dim)

E_i = Elastic modulus of intact rock from tests (ksi)

For critical or large structures, determination of rock mass modulus (E_m) using in-situ tests may be warranted. Refer to Sabatini et al. (2002) for descriptions of suitable in-situ tests.

Table 10.4.6.5-1—Estimation of E_m Based on RQD (after O'Neill and Reese, 1999)

RQD (percent)	E_m/E_i	
	Closed Joints	Open Joints
100	1.00	0.60
70	0.70	0.10
50	0.15	0.10
20	0.05	0.05

Table C10.4.6.5-1—Summary of Elastic Moduli for Intact Rock (modified after Kulhawy, 1978)

Rock Type	No. of Values	No. of Rock Types	Elastic Modulus, E_i (ksi $\times 10^3$)			Standard Deviation (ksi $\times 10^3$)
			Maximum	Minimum	Mean	
Granite	26	26	14.5	0.93	7.64	3.55
Diorite	3	3	16.2	2.48	7.45	6.19
Gabbro	3	3	12.2	9.8	11.0	0.97
Diabase	7	7	15.1	10.0	12.8	1.78
Basalt	12	12	12.2	4.20	8.14	2.60
Quartzite	7	7	12.8	5.29	9.59	2.32
Marble	14	13	10.7	0.58	6.18	2.49
Gneiss	13	13	11.9	4.13	8.86	2.31
Slate	11	2	3.79	0.35	1.39	0.96
Schist	13	12	10.0	0.86	4.97	3.18
Phyllite	3	3	2.51	1.25	1.71	0.57
Sandstone	27	19	5.68	0.09	2.13	1.19
Siltstone	5	5	4.76	0.38	2.39	1.65
Shale	30	14	5.60	0.001	1.42	1.45
Limestone	30	30	13.0	0.65	5.7	3.73
Dolostone	17	16	11.4	0.83	4.22	3.44

Poisson's ratio for rock should be determined from tests on intact rock core.

Where tests on rock core are not practical, Poisson's ratio may be estimated from Table C10.4.6.5-2.

Table C10.4.6.5-2—Summary of Poisson's Ratio for Intact Rock (modified after Kulhawy, 1978)

Rock Type	No. of Values	No. of Rock Types	Poisson's Ratio, ν			Standard Deviation
			Maximum	Minimum	Mean	
Granite	22	22	0.39	0.09	0.20	0.08
Gabbro	3	3	0.20	0.16	0.18	0.02
Diabase	6	6	0.38	0.20	0.29	0.06
Basalt	11	11	0.32	0.16	0.23	0.05
Quartzite	6	6	0.22	0.08	0.14	0.05
Marble	5	5	0.40	0.17	0.28	0.08
Gneiss	11	11	0.40	0.09	0.22	0.09
Schist	12	11	0.31	0.02	0.12	0.08
Sandstone	12	9	0.46	0.08	0.20	0.11
Siltstone	3	3	0.23	0.09	0.18	0.06
Shale	3	3	0.18	0.03	0.09	0.06
Limestone	19	19	0.33	0.12	0.23	0.06
Dolostone	5	5	0.35	0.14	0.29	0.08

10.4.6.6—Erodibility of Rock

Consideration should be given to the physical characteristics of the rock and the condition of the rock mass when determining a rock's susceptibility to erosion in the vicinity of bridge foundations. Physical characteristics that should be considered in the assessment of erodibility include cementing agents, mineralogy, joint spacing, and weathering.

C10.4.6.6

There is no consensus on how to determine erodibility of rock masses near bridge foundations. Refer to Richardson and Davis (2001) "Evaluating Scour at Bridges—Fourth Edition", Mayne et al. (2001), Appendix M for guidance on two proposed methods. The first method was proposed in an FHWA memorandum of July 1991 and consists of evaluating various rock index properties. The second method is documented in Smith (1994) "Preliminary Procedure to Evaluate Scour in Bedrock" which uses the erodibility index proposed by G. W. Annandale. The Engineer should consider the appropriateness of these two methods when determining the potential for a rock mass to scour.

10.5—LIMIT STATES AND RESISTANCE FACTORS**10.5.1—General**

The limit states shall be as specified in Article 1.3.2; foundation-specific provisions are contained in this Section.

Foundations shall be proportioned so that the factored resistance is not less than the effects of the factored loads specified in Section 3.

10.5.2—Service Limit States**10.5.2.1—General**

Foundation design at the service limit state shall include:

- Settlements,

C10.5.2.1

In bridges where the superstructure and substructure are not integrated, settlement corrections can be made by jacking and shimming bearings. Article 2.5.2.3 requires jacking provisions for these bridges.

- Horizontal movements,
- Overall stability, and
- Scour at the design flood.

Consideration of foundation movements shall be based upon structure tolerance to total and differential movements, rideability and economy. Foundation movements shall include all movement from settlement, horizontal movement, and rotation.

Bearing resistance estimated using the presumptive allowable bearing pressure for spread footings, if used, shall be applied only to address the service limit state.

10.5.2.2—Tolerable Movements and Movement Criteria

Foundation movement criteria shall be consistent with the function and type of structure, anticipated service life, and consequences of unacceptable movements on structure performance. Foundation movement shall include vertical, horizontal, and rotational movements. The tolerable movement criteria shall be established by either empirical procedures or structural analyses, or by consideration of both.

Foundation settlement shall be investigated using all applicable loads in the Service I Load Combination specified in Table 3.4.1-1. Transient loads may be omitted from settlement analyses for foundations bearing on or in cohesive soil deposits that are subject to time-dependant consolidation settlements.

All applicable service limit state load combinations in Table 3.4.1-1 shall be used for evaluating horizontal movement and rotation of foundations.

Horizontal movement criteria should be established at the top of the foundation based on the tolerance of the structure to lateral movement, with consideration of the column length and stiffness.

10.5.2.3—Overall Stability

The evaluation of overall stability of earth slopes with or without a foundation unit shall be investigated at the service limit state as specified in Article 11.6.2.3.

The cost of limiting foundation movements should be compared with the cost of designing the superstructure so that it can tolerate larger movements or of correcting the consequences of movements through maintenance to determine minimum lifetime cost. The Owner may establish more stringent criteria.

The design flood for scour is defined in Article 2.6.4.4.2, and is specified in Article 3.7.5 as applicable at the service limit state.

Presumptive bearing pressures were developed for use with working stress design. These values may be used for preliminary sizing of foundations, but should generally not be used for final design. If used for final design, presumptive values are only applicable at service limit states.

C10.5.2.2

Experience has shown that bridges can and often do accommodate more movement and/or rotation than traditionally allowed or anticipated in design. Creep, relaxation, and redistribution of force effects accommodate these movements. Some studies have been made to synthesize apparent response. These studies indicate that angular distortions between adjacent foundations greater than 0.008 rad. in simple spans and 0.004 rad. in continuous spans should not be permitted in settlement criteria (Moulton et al., 1985; DiMillio, 1982; Barker et al., 1991). Other angular distortion limits may be appropriate after consideration of:

- cost of mitigation through larger foundations, realignment or surcharge,
- rideability,
- aesthetics, and
- safety.

Rotation movements should be evaluated at the top of the substructure unit in plan location and at the deck elevation.

Tolerance of the superstructure to lateral movement will depend on bridge seat or joint widths, bearing type(s), structure type, and load distribution effects.

10.5.2.4—Abutment Transitions

Vertical and horizontal movements caused by embankment loads behind bridge abutments shall be investigated.

C10.5.2.4

Settlement of foundation soils induced by embankment loads can result in excessive movements of substructure elements. Both short and long term settlement potential should be considered.

Settlement of improperly placed or compacted backfill behind abutments can cause poor rideability and a possibly dangerous bump at the end of the bridge. Guidance for proper detailing and material requirements for abutment backfill is provided in Cheney and Chassie (2000).

Lateral earth pressure behind and/or lateral squeeze below abutments can also contribute to lateral movement of abutments and should be investigated, if applicable.

10.5.3—Strength Limit States**10.5.3.1—General**

Design of foundations at strength limit states shall include consideration of the nominal geotechnical and structural resistances of the foundation elements. Design at strength limit states shall not consider the deformations required to mobilize the nominal resistance, unless a definition of failure based on deformation is specified.

The design of all foundations at the strength limit state shall consider:

- Structural resistance and
- Loss of lateral and vertical support due to scour at the design flood event.

C10.5.3.1

For the purpose of design at strength limit states, the nominal resistance is considered synonymous with the ultimate capacity of an element as previously defined under allowable stress design, i.e., AASHTO (2002).

For design of foundations such as piles or drilled shafts that may be based directly on static load tests, or correlation to static load tests, the definition of failure may include a deflection-limited criteria.

Structural resistance includes checks for axial, lateral and flexural resistance.

The design event for scour is defined in Section 2 and is specified in Article 3.7.5 as applicable at the strength limit state.

10.5.3.2—Spread Footings

The design of spread footings at the strength limit state shall also consider:

- Nominal bearing resistance,
- Overturning or excessive loss of contact,
- Sliding at the base of footing, and
- constructability.

C10.5.3.2

The designer should consider whether special construction methods are required to bear a spread footing at the design depth. Consideration should be given to the potential need for shoring, cofferdams, seals, and/or dewatering. Basal stability of excavations should be evaluated, particularly if dewatering or cofferdams are required.

Effort should be made to identify the presence of expansive/collapsible soils in the vicinity of the footing. If present, the structural design of the footing should be modified to accommodate the potential impact to the performance of the structure, or the expansive/collapsible soils should be removed or otherwise remediated. Special conditions such as the presence of karstic formations or mines should also be evaluated, if present.

10.5.3.3—Driven Piles

The design of pile foundations at the strength limit state shall also consider:

- Axial compression resistance for single piles,
- Pile group compression resistance,
- Uplift resistance for single piles,
- Uplift resistance for pile groups,
- Pile punching failure into a weaker stratum below the bearing stratum,
- Single pile and pile group lateral resistance, and
- Constructability, including pile drivability.

10.5.3.4—Drilled Shafts

The design of drilled shaft foundations at the strength limit state shall also consider:

- Axial compression resistance for single drilled shafts,
- Shaft group compression resistance,
- Uplift resistance for single shafts,
- Uplift resistance for shaft groups,
- Single shaft and shaft group lateral resistance,
- Shaft punching failure into a weaker stratum below the bearing stratum, and
- Constructability, including method(s) of shaft construction.

10.5.3.5—Micropiles

The design of micropile foundations at the strength limit state shall also consider:

- Axial compression resistance for single micropile,
- Micropile group compression resistance,
- Uplift resistance for single micropile,
- Uplift resistance for micropile groups,
- Micropile group punching failure into a weaker stratum below the bearing stratum, and single micropile punching failure where tip resistance is considered,
- Single micropile and micropile group lateral resistance, and
- Constructability, including method(s) of micropile construction.

C10.5.3.3

The commentary in Article C10.5.3.2 is applicable if a pile cap is needed.

For pile foundations, as part of the evaluation for the strength limit states identified herein, the effects of downdrag, soil setup or relaxation, and buoyancy due to groundwater should be evaluated.

C10.5.3.4

See commentary in Articles C10.5.3.2 and C10.5.3.3.

The design of drilled shafts for each of these limit states should include the effects of the method of construction, including construction sequencing, whether the shaft will be excavated in the dry or if wet methods must be used, as well as the need for temporary or permanent casing to control caving ground conditions. The design assumptions regarding construction methods must carry through to the contract documents to provide assurance that the geotechnical and structural resistance used for design will be provided by the constructed product.

C10.5.3.5

The commentary in Article C10.5.3.2 is applicable if a pile cap is needed.

The design of micropiles for each of these limit states should include the effects of the method of construction for the micropile type to be constructed. The design assumptions regarding construction methods must carry through to the contract documents to provide assurance that the geotechnical and structural resistance used for design will be provided by the constructed product.

10.5.4—Extreme Events Limit States

10.5.4.1—Extreme Events Design

Foundations shall be designed for extreme events as applicable.

10.5.4.2—Liquefaction Design Requirements

A liquefaction assessment shall be conducted for Seismic Zones 3 and 4 if both of the following conditions are present:

- *Ground Water Level*—The groundwater level anticipated at the site is within 50 ft of the existing ground surface or the final ground surface, whichever is lower.
- *Soil Characteristics*—Low plasticity silts and sands within the upper 75 ft are characterized by one of the following conditions: (1) the corrected standard penetration test (*SPT*) blow count, $(N_1)_{60}$, is less than or equal to 25 blows/ft in sand and nonplastic silt layers, (2) the corrected cone penetration test (*CPT*) tip resistance, $q_{c1\%}$, is less than or equal to 150 in sand, and nonplastic silt layers, (3) the normalized shear wave velocity, V_{s1} , is less than 660 fps, or (4) a geologic unit is present at the site that has been observed to liquefy in past earthquakes.

Where loose to very loose saturated sands are within the subsurface soil profile such that liquefaction of these soils could impact the stability of the structure, the potential for liquefaction in Seismic Zone 2 should also be considered.

For sites that require an assessment of liquefaction, the potential effects of liquefaction on soils and foundations shall be evaluated. The assessment shall consider the following effects of liquefaction:

- Loss in strength in the liquefied layer or layers,
- Liquefaction-induced ground settlement,
- Flow failures, lateral spreading, and slope instability.

For sites where liquefaction occurs around bridge foundations, bridges should be analyzed and designed in two configurations as follows:

- *Nonliquefied Configuration*—The structure should be analyzed and designed, assuming no liquefaction occurs, using the ground response spectrum appropriate for the site soil conditions in a nonliquefied state.

C10.5.4.1

Extreme events include the check flood for scour, vessel and vehicle collision, seismic loading, and other site-specific situations that the Engineer determines should be included. Appendix A10 gives additional guidance regarding seismic analysis and design.

C10.5.4.2

All of the following general conditions are necessary for liquefaction to occur:

- A sustained ground acceleration that is large enough and acting over a long enough period of time to develop excess pore-water pressure, thereby reducing effective stress and soil strength.
- Predominantly cohesionless soil that has the right gradation and composition. Liquefaction has occurred in soils ranging from low plasticity silts to gravels. Clean or silty sands and nonplastic silts are most susceptible to liquefaction.
- The state of the soil is characterized by a density that is low enough for the soil to exhibit contractive behavior when sheared undrained under the initial effective overburden stress.
- The presence of groundwater, resulting in a saturated or nearly saturated soil.

Methods used to assess the potential for liquefaction range from empirically-based design methods to complex numerical, effective stress methods that can model the time-dependent generation of pore-water pressure and its effect on soil strength and deformation. Furthermore, dynamic performance soil tests such as cyclic simple shear or cyclic triaxial tests can be used to assess liquefaction susceptibility and behavior to be used as input for liquefaction analysis and design.

The most common method of assessing liquefaction involves the use of empirical methods (e.g., Youd et al., 2001). These methods provide an estimate of liquefaction potential based on *SPT* blowcounts, *CPT* cone tip resistance, or shear wave velocity. This type of analysis should be conducted as a baseline evaluation, even when more rigorous methods are used.

Youd et al. (2001) summarizes the consensus of the profession up to year 2000 regarding the use of the simplified methods. Since the publication of this consensus paper, various other modifications to the consensus approach have been introduced, including those by Cetin et al. (2004), Moss et al. (2006), and Boulanger and Idriss (2006). These more recent methods account for additions to the database on liquefaction, as

- *Liquefied Configuration*—The structure as designed in nonliquefied configuration above should be reanalyzed assuming that the layer has liquefied and the liquefied soil provides the appropriate residual resistance for lateral and axial deep foundation response analyses consistent with liquefied soil conditions (i.e., modified P - y curves, modulus of subgrade reaction, or t - z curves). The design spectrum should be the same as that used in the nonliquefied configuration.

With the Owner's approval, or as required by the Owner, a site-specific response spectrum that accounts for the modifications in spectral content from the liquefying soil may be developed. Unless approved otherwise by the Owner, the reduced response spectrum resulting from the site-specific analyses shall not be less than two-thirds of the spectrum developed at the ground surface using the general procedure described in Article 3.10.4.1 modified by the site factors in Article 3.10.3.2.

The Designer should provide explicit detailing of plastic hinging zones for both cases mentioned above since it is likely that locations of plastic hinges for the liquefied configuration are different than locations of plastic hinges for the nonliquefied configuration. Design requirements including shear reinforcement should be met for the liquefied and nonliquefied configuration. Where liquefaction is identified, plastic hinging in the foundation may be permitted with the Owner's approval.

For those sites where liquefaction-related permanent lateral ground displacements (e.g., flow, lateral spreading, or slope instability) are determined to occur, the effects of lateral displacements on the bridge and retaining structures should be evaluated. These effects can include increased lateral pressure on bridge foundations and retaining walls.

The effects of liquefaction-related, permanent lateral ground displacements on bridge and retaining wall performance should be considered separate from the inertial evaluation of the bridge structures. However, if large magnitude earthquakes dominate the seismic hazards, the bridge response evaluation should consider the potential simultaneous occurrence of:

- Inertial response of the bridge, and loss in ground response from liquefaction around the bridge foundations, and
- Predicted amounts of permanent lateral displacement of the soil.

well as refinements in the interpretation of case history data. The newer methods potentially offer improved estimates of liquefaction potential and can be considered for use.

The simplified empirical methods are suited for use to a maximum depth of approximately 75 ft. This depth limit relates to the database upon which the original empirical method was developed. Most of the database was from observations of liquefaction at depths less than 50 to 60 ft. Extrapolation of the simplified method beyond 75 ft is therefore of uncertain validity. This limitation should not be interpreted as meaning liquefaction does not occur beyond 75 ft. Rather, different methods should be used for greater depths, including the use of site-specific ground motion response modeling in combination with liquefaction testing in the laboratory.

The magnitude for the design earthquake must be determined when conducting liquefaction assessments using the simplified empirical procedures. The earthquake magnitude used to assess liquefaction can be determined from earthquake deaggregation data for the site, available through the USGS national seismic hazard website <http://earthquake.usgs.gov/research/hazmaps/> based on the 975-yr return period (i.e., five percent in 50 yr within the USGS website). If a single or a few larger magnitude earthquakes dominate the deaggregation, the magnitude of the single dominant earthquake or the mean of the few dominant earthquakes in the deaggregation should be used.

Liquefaction is generally limited to granular soils, such as sands and non-plastic silts. Loose gravels also can liquefy if drainage is prevented such as might occur if a layer of clay or frozen soil is located over the gravel. Methods for eliminating sites based on soil type have been developed, as discussed by Youd et al., (2001), Bray and Sancio (2006), and Boulanger and Idriss (2006). These methods can be used to screen the potential for liquefaction in certain soil types. In the past soil screening with regard to silts was done using the Chinese criteria (Kramer, 1996). Recent studies (Bray and Sancio, 2006; Boulanger and Idriss, 2006) indicate that the Chinese criteria are unconservative, and therefore their use should be discontinued.

Two criteria for assessing liquefaction susceptibility of soils have been recently proposed as replacements to the Chinese criteria:

- Boulanger and Idriss (2006) recommend considering a soil to have clay-like behavior (i.e., not susceptible to liquefaction) if the plasticity index (PI) ≥ 7 .
- Bray and Sancio (2006) suggest that a soil with a $PI < 12$ and a ratio of water content to liquid limit (wc/LL) > 0.85 will be susceptible to liquefaction.

There is no current consensus on the preferred of the two criteria, and, therefore, either method may be used, unless the Owner has a specific preference.

If inelastic deformations are expected in the foundation due to liquefaction-induced effects, a quantitative assessment of such effects should be considered. Such assessment may follow the approach outlined for SDC D in the *AASHTO Guide Specifications for LRFD Seismic Bridge Design*.

To determine the location of soils that are adequately saturated for liquefaction to occur, the seasonally averaged groundwater elevation should be used. Groundwater fluctuations caused by tidal action or seasonal variations will cause the soil to be saturated only during a limited period of time, significantly reducing the risk that liquefaction could occur within the zone of fluctuation.

Liquefaction evaluation is required only for sites meeting requirements for Seismic Zones 3 and 4, provided that the soil is saturated and of a type that is susceptible to liquefaction. For loose to very loose sand sites (e.g., $(N_1)_{60} < 10$ bpf or $q_{c1N} < 75$), a potential exists for liquefaction in Seismic Zone 2, if the acceleration coefficient, A_s , is 0.15 or higher. The potential for and consequences of liquefaction for these sites will depend on the dominant magnitude for the seismic hazard. As the magnitude decreases, the liquefaction resistance of the soil increases due to the limited number of earthquake loading cycles. Generally, if the magnitude is 6 or less, even in these very loose soils, either the potential for liquefaction is very low or the extent of liquefaction is very limited. Nevertheless, a liquefaction assessment should be made if loose to very loose sands are present to a sufficient extent to impact bridge stability and A_s is greater than or equal to 0.15. These loose to very loose sands are likely to be present in hydraulically placed fills and alluvial or estuarine deposits near rivers and waterfronts.

During liquefaction, pore-water pressure build-up occurs, resulting in loss of strength and then settlement as the excess pore-water pressures dissipate after the earthquake. The potential effects of strength loss and settlement include:

- *Slope Failure, Flow Failure, or Lateral Spreading*—The strength loss associated with pore-water pressure build-up can lead to slope instability. Generally, if the factor of safety against liquefaction is less than approximately 1.2 to 1.3, a potential for pore-water pressure build-up will occur, and the effects of this build-up should be assessed. If the soil liquefies, the stability is determined by the residual strength of the soil. The residual strength of liquefied soils can be determined using empirical methods developed by Seed and Harder (1990), Olson and Stark (2002), and others. Loss of lateral resistance can allow abutment soils to move laterally, resulting in bridge substructure distortion and unacceptable deformations and moments in the superstructure.
- *Reduced Foundation Bearing Resistance*—Liquefied strength is often a fraction of nonliquefied strength. This loss in strength can result in large displacements or bearing failure. For this reason, spread footing foundations are not recommended where liquefiable soils occur unless the spread footing is located below the maximum depth of liquefaction or soil improvement techniques are used to mitigate the effects of liquefaction.

- *Reduced Soil Stiffness and Loss of Lateral Support for Deep Foundations*—This loss in strength can change the lateral response characteristics of piles and shafts under lateral load.
- *Vertical Ground Settlement as Excess Pore-Water Pressures Induced by Liquefaction Dissipate, Resulting in Downdrag Loads on Deep Foundations*—If liquefaction-induced downdrag loads can occur, the downdrag loads should be assessed as specified in Article 3.11.8.

Most liquefaction-related damage to bridges during past earthquakes has been the result of lateral movement of the soil, causing severe column distortion and potential structure collapse. Therefore, a thorough analysis of the effects of lateral soil movement due to liquefaction on the structure is necessary. If there is potential for significant soil movement, the structure design should meet the requirements of Seismic Zone 4.

The effects of liquefaction will depend in large part on the amount of soil that liquefies and the location of the liquefied soil with respect to the foundation. On sloping ground, lateral flow, spreading, and slope instability can occur on relatively thin layers of liquefiable soils, whereas the effects of thin liquefied layer on the lateral response of piles or shafts (without lateral ground movement) may be negligible. Likewise, a thin liquefied layer at the ground surface results in essentially no downdrag loads, whereas the same liquefied layer deeper in the soil profile could result in large downdrag loads. Given these potential variations, site investigation plays a fundamental part of the liquefaction assessment. Article 10.4 identifies requirements for site investigations.

When assessing the effects of liquefaction on bridge response, the recommendations herein require that structure be designed for two cases, one in which the full seismic acceleration is applied to the structure assuming the soil does not liquefy, and one in which the full seismic acceleration is applied to the structure assuming the soil does liquefy but the spectrum is unchanged by liquefaction. This approach should produce conservative results for bridges with periods less than 1 sec. However, Youd and Carter (2005) suggest that at periods greater than 1 second, it is possible for liquefaction to result in higher spectral accelerations than occur for equivalent nonliquefied cases, all other conditions being equal. For Site Class C or D and bridges with periods greater than 1 sec., the Designer may consider using a response spectrum constructed using Site Class E for the liquefied condition. Alternately, site-specific ground motion response evaluations may be used to evaluate this potential.

There is currently no consensus on how to address this issue of timing of seismic acceleration and the development of full liquefaction and its combined impact on the structure without resorting to more rigorous analyses, such as by using nonlinear, effective stress methods. In general, the larger the earthquake magnitude (e.g., $M > 8$), the longer the period of time over which strong shaking acts, and the more likely the strong shaking and liquefaction effects will be acting concurrently. The smaller the earthquake magnitude, the more likely that these two effects will not be concurrent, in which case the peak inertial response of the bridge may occur before much, if any, reduction in soil support from liquefaction occurs.

Site-specific dynamic ground motion response analyses offers one method of evaluating the effects of pore-water pressure increases and timing on the development of the response spectrum. These analyses can be conducted using a nonlinear, effective stress method that accounts for the build-up in pore-water pressure and stiffness degradation in liquefiable layers. Use of this approach requires considerable skill in terms of selecting model parameters, particularly the pore pressure model. The complexity of this approach is such that Owner's approval is mandatory, and it is highly advisable that an independent peer review panel with expertise in nonlinear, effective stress modeling be used to review the methods and the resulting spectrum.

The limit of two-thirds for reduction of the liquefied response spectrum below the nonliquefied spectrum is meant to apply to any ordinate of the response spectrum. Generally, liquefied conditions may produce significant reductions in the shorter period range, but the reductions will be smaller or could be increased over nonliquefied conditions in the longer period range over about 1–2 sec. The developer of the site response analysis should capture accurate estimates of response for all periods that could be of importance in both nonliquefied and liquefied conditions. This consideration is particularly important if the conventional spectral shapes of Article 3.10.4.1 are being used.

The timing of liquefaction relative to the development of strong shaking also can be an important consideration for sites where lateral ground movement occurs. Both the development of liquefaction and the ground movement are dependent on the size and magnitude of the earthquake, but they do not necessarily occur at the same time. This issue is especially important when determining how to combine the inertial response of the structure and the response to lateral movement of the soil against the foundations and other substructure elements due to lateral spreading, slope instability, and flow failure. Current practice is to consider these two mechanisms to be independent, and therefore, the analyses are decoupled; i.e., the analysis is first performed to evaluate inertial effects during liquefaction following the same guidance as for level-

ground sites, and then the foundation is evaluated for the moving ground, but without the inertial effects of the bridge superimposed. For critical bridges or in areas where very large magnitude earthquakes could occur, detailed studies addressing the two mechanisms acting concurrently may be warranted. This timing issue also affects liquefaction-induced downdrag, in that settlement and downdrag generally does not occur until the pore pressures induced by ground shaking begin to dissipate after shaking ceases.

For assessment of existing structures, the Designer should consider using Seismic Zone 4 regardless of the magnitude of A_s , even when significant lateral soil movement is not expected, if the structure is particularly weak with regard to its ability to resist the forces and displacements that could be caused by liquefaction. Examples of weaknesses that could exacerbate the impact of liquefaction to the structure include presence of shallow foundations, deep foundations tipped in liquefiable soil, very limited bridge support lengths that have little tolerance of lateral movement of the substructure, deterioration of superstructure or substructure components due to advanced age of the structure or severe environmental conditions, and the absence of substructure redundancy.

The intent of these Specifications is to limit inelastic deformations under seismic loading to above-ground locations that can be inspected. However, if liquefaction occurs, it may be difficult or impossible to restrict inelastic action solely to above-ground locations without site improvement. If inelastic deformations are expected in the foundation, then the Owner may consider installation of devices that permit post-earthquake assessment; for example, installation of inclinometer tubes in drilled shafts permits limited evaluation of the deformations of the foundation, which would otherwise be impossible to inspect at any significant depth. Permitting inelastic behavior below the ground implies that the shaft or piles will be damaged, possibly along with other parts of the bridge, and may need to be replaced.

Design options range from (a) an acceptance of the movements with significant damage to the piles and columns if the movements are large (possibly requiring demolition but still preserving the no-collapse philosophy) to (b) designing the piles to resist the forces generated by lateral spreading. Between these options are a range of mitigation measures to limit the amount of movement to tolerable levels for the desired performance objective. However, tolerable structural movements should be evaluated quantitatively.

Quantitative assessments of liquefaction-induced deformations on foundations may be accomplished using the nonlinear static “push over” methodology. However, such analysis is complicated by the need to model nonlinear P - y behavior of the liquefied soil along with the nonlinear behavior of the structure. Analyses where the liquefied soil is represented by appropriate

residual resistance (P - y curves or modulus of subgrade reaction values) will generally provide conservative results for the actual inelastic behavior of the foundation structural elements. The approach for such analyses should be developed on a case-by-case basis due to the varied conditions found in liquefiable sites. Careful coordination between the geotechnical and structural engineers is essential to estimating the expected response and to evaluating whether the structure can tolerate the response. Often mitigation strategies may be required to reduce structural movements.

Mitigation of the effects of liquefaction-induced settlement or lateral soil movement may include ground stabilization to either prevent liquefaction or add strength to keep soil deformation from occurring, foundation or superstructure modifications to resist the forces and accommodate the deformations that may occur, or both.

It is often cost prohibitive to design the bridge foundation system to resist the loads imposed by liquefaction-induced lateral loads, especially if the depth of liquefaction extends more than about 20 ft below the ground surface and if a nonliquefied crust is part of the failure surface. Ground improvement to mitigate the liquefaction hazard is the likely alternative if it is not practical to design the foundation system to accommodate the lateral loads.

The primary ground improvement techniques to mitigate liquefaction fall into five general categories, namely removal and replacement, densification, reinforcement, altering the soil composition, and enhanced drainage. Any one or a combination of methods can be used. However, drainage improvement is not currently considered adequately reliable to prevent liquefaction-induced, excess pore-water pressure build-up due to (1) the time required for excess pore-water pressures to dissipate through the drainage paths, and (2) the potential for drainage materials to become clogged during installation and in service. In addition, with drainage enhancements some settlement is still likely. Therefore, drainage enhancements should not be used as a means to fully mitigate liquefaction. For further discussion of ground improvement methods, see FHWA-SA-98-086, *Ground Improvement Technical Summaries* (Elias, et al., 2000); FHWA-SA-95-037; Geotechnical Engineering Circular No. 1, *Dynamic Compaction* (Lukas, 1995); and FHWA/RD-83/O2C, *Design and Construction of Stone Columns* (Barkdale and Bachus, 1983).

The use of large diameter shafts in lieu of the conventional pile cap foundation type may be considered in order to achieve the lateral strength and stiffness required to sustain the column demand while minimizing the foundation exposed surface area normal to the lateral flow direction.

10.5.5—Resistance Factors

10.5.5.1—Service Limit States

Resistance factors for the service limit states shall be taken as 1.0, except as provided for overall stability in Article 11.6.2.3.

A resistance factor of 1.0 shall be used to assess the ability of the foundation to meet the specified deflection criteria after scour due to the design flood.

10.5.5.2—Strength Limit States

10.5.5.2.1—General

Resistance factors for different types of foundation systems at the strength limit state shall be taken as specified in Articles 10.5.5.2.2, 10.5.5.2.3, 10.5.5.2.4, and 10.5.5.2.5, unless regionally specific values or substantial successful experience is available to justify higher values.

C10.5.5.2.1

Regionally specific values should be determined based on substantial statistical data combined with calibration or substantial successful experience to justify higher values. Smaller resistance factors should be used if site or material variability is anticipated to be unusually high or if design assumptions are required that increase design uncertainty that have not been mitigated through conservative selection of design parameters.

Certain resistance factors in Articles 10.5.5.2.2, 10.5.5.2.3, 10.5.5.2.4, and 10.5.5.2.5 are presented as a function of soil type, e.g., sand or clay. Naturally occurring soils do not fall neatly into these two classifications. In general, the terms “sand” and “cohesionless soil” may be connoted to mean drained conditions during loading, while “clay” or “cohesive soil” implies undrained conditions. For other or intermediate soil classifications, such as silts or gravels, the designer should choose, depending on the load case under consideration, whether the resistance provided by the soil will be a drained or undrained strength, and select the method of computing resistance and associated resistance factor accordingly.

In general, resistance factors for bridge and other structure design have been derived to achieve a reliability index, β , of 3.5, an approximate probability of failure, P_f , of 1 in 5,000. However, past geotechnical design practice has resulted in an effective reliability index, β , of 3.0, or an approximate probability of a failure of 1 in 1,000, for foundations in general, and for highly redundant systems, such as pile groups, an approximate reliability index, β , of 2.3, an approximate probability of failure of 1 in 100 (Zhang et al., 2001; Paikowsky et al., 2004; Allen, 2005). If the resistance factors provided in this Article are adjusted to account for regional practices using statistical data and calibration, they should be developed using the β values provided above, with consideration given to the redundancy in the foundation system.

For bearing resistance, lateral resistance, and uplift calculations, the focus of the calculation is on the individual foundation element, e.g., a single pile or drilled shaft. Since these foundation elements are usually part of a foundation unit that contains multiple

elements, failure of one of these foundation elements usually does not cause the entire foundation unit to reach failure, i.e., due to load sharing and overall redundancy. Therefore, the reliability of the foundation unit is usually more, and in many cases considerably more, than the reliability of the individual foundation element. Hence, a lower reliability can be successfully used for redundant foundations than is typically the case for the superstructure.

Note that not all of the resistance factors provided in this Article have been derived using statistical data from which a specific β value can be estimated, since such data were not always available. In those cases, where data were not available, resistance factors were estimated through calibration by fitting to past allowable stress design safety factors, e.g., the AASHTO *Standard Specifications for Highway Bridges* (2002).

Additional discussion regarding the basis for the resistance factors for each foundation type and limit state is provided in Articles 10.5.5.2.2, 10.5.5.2.3, 10.5.5.2.4, and 10.5.5.2.5. Additional, more detailed information on the development of the resistance factors for foundations provided in this Article, and a comparison of those resistance factors to previous Allowable Stress Design practice, e.g., AASHTO (2002), is provided in Allen (2005).

Scour design for the design flood must satisfy the requirement that the factored foundation resistance after scour is greater than the factored load determined with the scoured soil removed. The resistance factors will be those used in the Strength Limit State, without scour.

The foundation resistance after scour due to the design flood shall provide adequate foundation resistance using the resistance factors given in this Article.

10.5.5.2.2—Spread Footings

C10.5.5.2.2

The resistance factors provided in Table 10.5.5.2.2-1 shall be used for strength limit state design of spread footings, with the exception of the deviations allowed for local practices and site specific considerations in Article 10.5.5.2.

Table 10.5.5.2.2-1—Resistance Factors for Geotechnical Resistance of Shallow Foundations at the Strength Limit State

		Method/Soil/Condition	Resistance Factor
Bearing Resistance	ϕ_b	Theoretical method (Munfakh et al., 2001), in clay	0.50
		Theoretical method (Munfakh et al., 2001), in sand, using <i>CPT</i>	0.50
		Theoretical method (Munfakh et al., 2001), in sand, using <i>SPT</i>	0.45
		Semi-empirical methods (Meyerhof, 1957), all soils	0.45
		Footings on rock	0.45
		Plate Load Test	0.55
Sliding	ϕ_τ	Precast concrete placed on sand	0.90
		Cast-in-Place Concrete on sand	0.80
		Cast-in-Place or precast Concrete on Clay	0.85
		Soil on soil	0.90
	ϕ_{ep}	Passive earth pressure component of sliding resistance	0.50

The resistance factors in Table 10.5.5.2.2-1 were developed using both reliability theory and calibration by fitting to Allowable Stress Design (ASD). In general, ASD safety factors for footing bearing capacity range from 2.5 to 3.0, corresponding to a resistance factor of approximately 0.55 to 0.45, respectively, and for sliding, an ASD safety factor of 1.5, corresponding to a resistance factor of approximately 0.9. Calibration by fitting to ASD controlled the selection of the resistance factor in cases where statistical data were limited in quality or quantity. The resistance factor for sliding of cast-in-place concrete on sand is slightly lower than the other sliding resistance factors based on reliability theory analysis (Barker et al., 1991). The higher interface friction coefficient used for sliding of cast-in-place concrete on sand relative to that used for precast concrete on sand causes the cast-in-place concrete sliding analysis to be less conservative, resulting in the need for the lower resistance factor. A more detailed explanation of the development of the resistance factors provided in Table 10.5.5.2.2-1 is provided in Allen (2005).

The resistance factors for plate load tests and passive resistance were based on engineering judgment and past ASD practice.

10.5.5.2.3—Driven Piles

Resistance factors shall be selected from Table 10.5.5.2.3-1 based on the method used for determining the driving criterion necessary to achieve the required nominal pile bearing resistance.

Regarding load tests, and dynamic tests with signal matching, the number of tests to be conducted to justify the design resistance factors selected should be based on the variability in the properties and geologic stratification of the site to which the test results are to be applied. A site shall be defined as a project site, or a portion of it, where the subsurface conditions can be characterized as geologically similar in terms of subsurface stratification, i.e., sequence, thickness, and geologic history of strata, the engineering properties of the strata, and groundwater conditions.

C10.5.5.2.3

Where nominal pile bearing resistance is determined by static load test, dynamic testing, wave equation, or dynamic formulas, the uncertainty in the nominal resistance is strictly due to the reliability of the resistance determination method used in the field during pile installation.

In most cases, the nominal bearing resistance of each production pile is field-verified based on compliance with a driving criterion developed using a dynamic method (see Articles 10.7.3.8.2, 10.7.3.8.3, 10.7.3.8.4, or 10.7.3.8.5). The actual penetration depth where the pile is stopped using the driving criterion (e.g., a blow count measured during pile driving) will likely not be the same as the estimated depth from the static analysis. Hence, the reliability of the nominal pile bearing resistance is dependent on the reliability of the method used to verify the nominal resistance during pile installation (see Allen, 2005, for additional discussion on this issue). Therefore, the resistance factor for the field verification method should be used to determine the number of piles of a given nominal resistance needed to resist the factored loads in the strength limit state.

If the resistance factors provided in Table 10.5.5.2.3-1 are to be applied to small pile groups, the resistance factor values in the table should be reduced by 20 percent to reflect the reduced ability for overstressing of an individual foundation element to be carried by adjacent foundation elements. The minimum size of a pile group necessary to provide significant opportunity for load sharing ranges from 2 or 3 (Isenhower and Long, 1997) to 5 (Paikowsky, et al., 2004).

The ability to share load between structural elements should an overstress occur is addressed in Article 1.3.4 through the use of η_R . The values for η_R provided in that Article have been developed in general for the superstructure, and no specific guidance on the application of η_R to foundations is provided. The η_R factor values recommended in Article 1.3.4 are not adequate to address this ability to shed load to other foundation elements when some of the foundation elements become overstressed, based on the results provided by Paikowsky et al. (2004) and others (see also Allen, 2005). Therefore, the resistance factors specified in Table 10.5.5.2.3-1 should be reduced based on the guidance provided in this Article to account for the lack of load sharing opportunities due to the small pile group size.

Dynamic methods may underpredict the nominal axial resistance of piles driven in soft silts or clays where a large amount of setup is anticipated and it is not feasible to perform static load or dynamic tests over a sufficient length of time to assess soil setup.

See Allen (2005) for an explanation on the development of the resistance factors for pile foundation design.

For all axial resistance calculation methods, the resistance factors were, in general, developed from load test results obtained on piles with diameters of 24 in. or less. Very little data were available for larger diameter piles. Therefore, these resistance factors should be used with caution for design of significantly larger diameter piles. In general, experience has shown that the static analysis methods identified in Table 10.5.5.2.3-1 tend to significantly overestimate the available nominal resistance for larger diameter piles. A static or dynamic load test should be considered if piles larger than 24 in. in diameter are anticipated.

Where driving criteria are established based on a static load test, the potential for site variability should be considered. The number of load tests required should be established based on the characterization of site subsurface conditions by the field and laboratory exploration and testing program.

One of the following alternative approaches may be used to address site variability when extrapolating pile load test results, and the application of driving criteria from those load test results, to piles not load tested:

Note that a site as defined herein may be only a portion of the area in which the structure (or structures) is located. For sites where conditions are highly variable, a site could even be limited to a single pier.

1. Divide up the site into zones where subsurface conditions are relatively uniform using engineering judgment, conducting one static pile load test in each zone, and dynamic testing with signal matching on a minimum of two percent of the production piles, but no less than two production piles. A resistance factor of 0.80 is recommended if this approach is used. If production pile dynamic testing is not conducted, then a resistance factor of 0.75 should be used.
2. Characterize the site variability and select resistance factors using the approach described by Paikowsky et al. (2004).

The dynamic testing with signal matching should be evenly distributed within a pier and across the entire structure. However, within a particular footing, an increase in safety is realized where the most heavily loaded piles are tested.

The resistance factors in Table 10.5.5.2.3-1 for the case where dynamic testing is conducted without static load testing were developed using reliability theory for beginning of redrive (BOR) conditions. These resistance factors may be used for end of driving (EOD) conditions, but it should be recognized that dynamic testing with signal matching at EOD will likely produce conservative results because soil set up, which causes nominal pile bearing resistance to increase, is not taken into account. If, instead, relaxation is anticipated to occur, these resistance factors for dynamic testing should only be used at BOR.

The 0.50 resistance factor in Table 10.5.5.2.3-1 for use of the wave equation without dynamic measurements to estimate nominal pile bearing resistance is based on calibration by fitting to past allowable stress design practice. Using default wave equation hammer and soil input values, reliability theory calibrations performed by Paikowsky et al. (2004) suggest that a resistance factor of 0.40 should be used if the wave equation is used to estimate nominal pile bearing resistance. Their recommendation is more conservative than the resistance factor implied by past allowable stress design practice. Their recommendation should be considered representative of the reliability of the wave equation to estimate nominal pile bearing resistance by designers who lack experience with the wave equation and its application to local or regional subsurface conditions. Application of default wave equation input parameters without consideration to local site conditions and observed hammer performance in combination with this lower resistance factor is not recommended.

Local experience or site-specific test results should be used to refine the wave equation soil input values, or to at least use the input values selected with greater confidence, and field verification of the hammer performance should be conducted to justify the use of the resistance factor of 0.50 provided in Table 10.5.5.2.3-1. Field verification of hammer performance is considered to be a direct measurement of either stroke or kinetic energy.

See Articles 10.7.3.8.2, 10.7.3.8.3, 10.7.3.8.4, and 10.7.3.8.5 for additional guidance regarding static pile load testing, dynamic testing and signal matching, wave equation analysis, and dynamic formulas, respectively, as they apply to the resistance factors provided in Table 10.5.5.2.3-1.

The dynamic pile formulas, i.e., FHWA modified Gates and Engineering News, identified in Table 10.5.5.2.3-1 require the pile hammer energy as an input parameter. The developed hammer energy should be used for this purpose, defined as the product of actual stroke developed during the driving of the pile (or equivalent stroke as determined from the bounce chamber pressure for double acting hammers) and the hammer ram weight.

The resistance factors provided in Table 10.5.5.2.3-1 are specifically applicable to the dynamic pile formula as provided in Article 10.7.3.8.5. Note that for the Engineering News (EN) formula, the built-in safety factor of 6 has been removed so that it predicts nominal resistance. Therefore, the resistance factor shown in Table 10.5.5.2.3-1 for EN formula should not be applied to the traditional “allowable stress” form of the equation.

The resistance factors for the dynamic pile formulas, i.e., FHWA modified Gates and EN, in Table 10.5.5.2.3-1 have been specifically developed for EOD conditions. Since static pile load test data, which include the effects of soil setup or relaxation (for the database used, primarily soil setup), were used to develop the resistance factors for these formulas, the resistance factors reflect soil setup occurring after the pile installation. At BOR, the blow count obtained already includes the soil setup. Therefore, a lower resistance factor for the driving formulas should be used for BOR conditions than the ones shown in Table 10.5.5.2.3-1 for EOD conditions. In general, dynamic testing should be conducted to verify nominal pile resistance at BOR in lieu of the use of driving formulas.

Paikowsky et al. (2004) indicate that the resistance factors for static pile resistance analysis methods can vary significantly for different pile types. The resistance factors presented are average values for the method. See Paikowsky et al. (2004) and Allen (2005) for additional information regarding this issue.

The resistance factor for the Nordlund/Thurman method was derived primarily using the Peck et al. (1974) correlation between $SPT N_{160}$ and the soil friction angle, using a maximum design soil friction angle of 36 degrees, assuming the contributing zone for the bearing resistance is from the tip to two pile diameters below the tip. These assumptions should be considered when using the resistance factor specified in Table 10.5.5.2.3-1 for this static analysis method.

For the clay static pile analysis methods, if the soil cohesion was not measured in the laboratory, the correlation between $SPT N$ and S_u by Hara et al. (1974)

was used for the calibration. Use of other methods to estimate S_u may require the development of resistance factors based on those methods.

The resistance factors provided for uplift of single piles are generally less than the resistance factors for axial side resistance under compressive loading. This is consistent with past practice that recognizes the side resistance in uplift is generally less than the side resistance under compressive loading, and is also consistent with the statistical calibrations performed in Paikowsky et al. (2004). Since the reduction in uplift resistance that occurs in tension relative to the side resistance in compression is taken into account through the resistance factor, the calculation of side resistance using a static pile resistance analysis method should not be reduced from what is calculated from the methods provided in Article 10.7.3.8.6.

For uplift, the number of pile load tests required to justify a specific resistance factor are the same as that required for determining compression resistance. Extrapolating the pile load test results to other untested piles as specified in Article 10.7.3.10 does create some uncertainty, since there is not a way to directly verify that the desired uplift resistance has been obtained for each production pile. This uncertainty has not been quantified. Therefore, it is recommended that a resistance factor of not greater than 0.60 be used if an uplift load test is conducted.

Regarding pile drivability analysis, the only source of load is from the pile driving hammer. Therefore, the load factors provided in Section 3 do not apply. In past practice, e.g., AASHTO (2002), no load factors were applied to the stresses imparted to the pile top by the pile hammer. Therefore, a load factor of 1.0 should be used for this type of analysis. Generally, either a wave equation analysis or dynamic testing, or both, are used to determine the stresses in the pile resulting from hammer impact forces. See Article 10.7.8 for the specific calculation of the pile structural resistance available for analysis of pile drivability. The structural resistance available during driving determined as specified in Article 10.7.8 considers the ability of the pile to handle the transient stresses resulting from hammer impact, considering variations in the materials, pile/hammer misalignment, and variations in the pile straightness and uniformity of the pile head impact surface.

Table 10.5.5.2.3-1—Resistance Factors for Driven Piles

Condition/Resistance Determination Method		Resistance Factor
Nominal Bearing Resistance of Single Pile—Dynamic Analysis and Static Load Test Methods, ϕ_{dyn}	Driving criteria established by successful static load test of at least one pile per site condition and dynamic testing* of at least two piles per site condition, but no less than 2% of the production piles	0.80
	Driving criteria established by successful static load test of at least one pile per site condition without dynamic testing	0.75
	Driving criteria established by dynamic testing* conducted on 100% of production piles	0.75
	Driving criteria established by dynamic testing,* quality control by dynamic testing* of at least two piles per site condition, but no less than 2% of the production piles	0.65
	Wave equation analysis, without pile dynamic measurements or load test but with field confirmation of hammer performance	0.50
	FHWA-modified Gates dynamic pile formula (End of Drive condition only)	0.40
	Engineering News (as defined in Article 10.7.3.8.5) dynamic pile formula (End of Drive condition only)	0.10

* Dynamic testing requires signal matching, and best estimates of nominal resistance are made from a restrrike. Dynamic tests are calibrated to the static load test, when available.

Table 10.5.5.2.3-1—Resistance Factors for Driven Piles (continued)

Condition/Resistance Determination Method		Resistance Factor
Nominal Bearing Resistance of Single Pile—Static Analysis Methods, Φ_{stat}	Side Resistance and End Bearing: Clay and Mixed Soils	
	α -method (Tomlinson, 1987; Skempton, 1951)	0.35
	β -method (Esrig & Kirby, 1979; Skempton, 1951)	0.25
	λ -method (Vijayvergiya & Focht, 1972; Skempton, 1951)	0.40
	Side Resistance and End Bearing: Sand	
	Nordlund/Thurman Method (Hannigan et al., 2005)	0.45
	<i>SPT</i> -method (Meyerhof)	0.30
	<i>CPT</i> -method (Schmertmann)	0.50
	End bearing in rock (Canadian Geotech. Society, 1985)	0.45
Block Failure, Φ_{b1}	Clay	0.60
Uplift Resistance of Single Piles, Φ_{up}	Nordlund Method	0.35
	α -method	0.25
	β -method	0.20
	λ -method	0.30
	<i>SPT</i> -method	0.25
	<i>CPT</i> -method	0.40
	Static load test	0.60
Dynamic test with signal matching	0.50	
Group Uplift Resistance, Φ_{ug}	All soils	0.50
Lateral Geotechnical Resistance of Single Pile or Pile Group	All soils and rock	1.0
Structural Limit State	Steel piles	See the provisions of Article 6.5.4.2
	Concrete piles	See the provisions of Article 5.5.4.2.1
	Timber piles	See the provisions of Article 8.5.2.2 and 8.5.2.3
Pile Drivability Analysis, Φ_{da}	Steel piles	See the provisions of Article 6.5.4.2
	Concrete piles	See the provisions of Article 5.5.4.2.1
	Timber piles	See the provisions of Article 8.5.2.2
	In all three Articles identified above, use ϕ identified as “resistance during pile driving”	

10.5.5.2.4—Drilled Shafts

Resistance factors shall be selected based on the method used for determining the nominal shaft resistance. When selecting a resistance factor for shafts in clays or other easily disturbed formations, local experience with the geologic formations and with typical shaft construction practices shall be considered.

Where the resistance factors provided in Table 10.5.5.2.4-1 are to be applied to a single shaft supporting a bridge pier, the resistance factor values in the Table should be reduced by 20 percent. Where the resistance factor is decreased in this manner, the η_R factor provided in Article 1.3.4 shall not be increased to address the lack of foundation redundancy.

The number of static load tests to be conducted to justify the resistance factors provided in Table 10.5.5.2.4-1 shall be based on the variability in the properties and geologic stratification of the site to which the test results are to be applied. A site, for the purpose of assessing variability, shall be defined in accordance with Article 10.5.5.2.3.

C10.5.5.2.4

The resistance factors in Table 10.5.5.2.4-1 were developed using either statistical analysis of shaft load tests combined with reliability theory (Paikowsky et al., 2004), fitting to allowable stress design (ASD), or both. Where the two approaches resulted in a significantly different resistance factor, engineering judgment was used to establish the final resistance factor, considering the quality and quantity of the available data used in the calibration. The available reliability theory calibrations were conducted for the Reese and O'Neill (1988) method, with the exception of shafts in intermediate geo-materials (IGMs), in which case the O'Neill and Reese (1999) method was used. In Article 10.8, the O'Neill and Reese (1999) method is recommended. See Allen (2005) for a more detailed explanation on the development of the resistance factors for shaft foundation design, and the implications of the differences in these two shaft design methods on the selection of resistance factors.

The information in the commentary to Article 10.5.5.2.3 regarding the number of load tests to conduct considering site variability applies to drilled shafts as well.

For single shafts, lower resistance factors are specified to address the lack of redundancy. See Article C10.5.5.2.3 regarding the use of η_R .

Where installation criteria are established based on one or more static load tests, the potential for site variability should be considered. The number of load tests required should be established based on the characterization of site subsurface conditions by the field and laboratory exploration and testing program. One or more static load tests should be performed per site to justify the resistance factor selection as discussed in Article C10.5.5.2.3, applied to drilled shafts installed within the site. See Article C10.5.5.2.3 for details on assessing site variability as applied to selection and use of load tests.

For the specific case of shafts in clay, the resistance factor recommended by Paikowsky et al. (2004) is much lower than the recommendation from Barker et al. (1991). Since the shaft design method for clay is nearly the same for both the 1988 and 1999 methods, a resistance factor that represents the average of the two resistance factor recommendations is provided in Table 10.5.5.2.4-1. This difference may point to the differences in local geologic formations and local construction practices, pointing to the importance of taking such issues into consideration when selecting resistance factors, especially for shafts in clay.

IGMs are materials that are transitional between soil and rock in terms of their strength and compressibility, such as residual soils, glacial tills, or very weak rock. See Article C10.8.2.2.3 for a more detailed definition of an IGM.

Since the mobilization of shaft base resistance is less certain than side resistance due to the greater deformation required to mobilize the base resistance, a lower resistance factor relative to the side resistance is provided for the base resistance in Table 10.5.5.2.4-1. O'Neill and Reese (1999) make further comment that the recommended resistance factor for tip resistance in sand is applicable for conditions of high quality control on the properties of drilling slurries and base cleanout procedures. If high quality control procedures are not used, the resistance factor for the O'Neill and Reese (1999) method for tip resistance in sand should be also be reduced. The amount of reduction should be based on engineering judgment.

Shaft compression load test data should be extrapolated to production shafts that are not load tested as specified in Article 10.8.3.5.6. There is no way to verify shaft resistance for the untested production shafts, other than through good construction inspection and visual observation of the soil or rock encountered in each shaft. Because of this, extrapolation of the shaft load test results to the untested production shafts may introduce some uncertainty. Statistical data are not available to quantify this at this time. Historically, resistance factors higher than 0.70, or their equivalent safety factor in previous practice, have not been used for shaft foundations. If the recommendations in Paikowsky, et al. (2004) are used to establish a resistance factor when shaft static load tests are conducted, in consideration of site variability, the resistance factors recommended by Paikowsky, et al. for this case should be reduced by 0.05, and should be less than or equal to 0.70 as specified in Table 10.5.5.2.4-1.

This issue of uncertainty in how the load test is applied to shafts not load tested is even more acute for shafts subjected to uplift load tests, as failure in uplift can be more abrupt than failure in compression. Hence, a resistance factor of 0.60 for the use of uplift load test results is recommended.

Table 10.5.5.2.4-1—Resistance Factors for Geotechnical Resistance of Drilled Shafts

Method/Soil/Condition		Resistance Factor	
Nominal Axial Compressive Resistance of Single-Drilled Shafts, ϕ_{stat}	Side resistance in clay	α -method (O'Neill and Reese, 1999)	0.45
	Tip resistance in clay	Total Stress (O'Neill and Reese, 1999)	0.40
	Side resistance in sand	β -method (O'Neill and Reese, 1999)	0.55
	Tip resistance in sand	O'Neill and Reese (1999)	0.50
	Side resistance in IGMs	O'Neill and Reese (1999)	0.60
	Tip resistance in IGMs	O'Neill and Reese (1999)	0.55
	Side resistance in rock	Horvath and Kenney (1979) O'Neill and Reese (1999)	0.55
	Side resistance in rock	Carter and Kulhawy (1988)	0.50
	Tip resistance in rock	Canadian Geotechnical Society (1985) Pressuremeter Method (Canadian Geotechnical Society, 1985) O'Neill and Reese (1999)	0.50
Block Failure, ϕ_{b1}	Clay	0.55	
Uplift Resistance of Single-Drilled Shafts, ϕ_{up}	Clay	α -method (O'Neill and Reese, 1999)	0.35
	Sand	β -method (O'Neill and Reese, 1999)	0.45
	Rock	Horvath and Kenney (1979) Carter and Kulhawy (1988)	0.40
Group Uplift Resistance, ϕ_{ug}	Sand and clay	0.45	
Horizontal Geotechnical Resistance of Single Shaft or Shaft Group	All materials	1.0	
Static Load Test (compression), ϕ_{load}	All Materials	0.70	
Static Load Test (uplift), ϕ_{upload}	All Materials	0.60	

10.5.5.2.5—Micropiles

Resistance factors shall be selected from Table 10.5.5.2.5-1 based on the method used for determining the nominal axial pile resistance. If the resistance factors provided in Table 10.5.5.2.5-1 are to be applied to piles in potentially creeping soils, highly plastic soils, weak rock, or other marginal ground type, the resistance factor values in the Table should be reduced by 20 percent to reflect greater design uncertainty.

C10.5.5.2.5

The resistance factors in Table 10.5.5.2.5-1 were calibrated by fitting to ASD procedures tempered with engineering judgment. The resistance factors in Table 10.5.5.2.5.-2 for structural resistance were calibrated by fitting to ASD procedures and are equal to or slightly more conservative than corresponding resistance factors from Section 5 of the AASHTO LRFD Specifications for reinforced concrete column design.

Table 10.5.5.2.5-1—Resistance Factors for Geotechnical Resistance of Axially Loaded Micropiles

Limit State	Method/ Ground Condition	Resistance Factor
Compression Resistance of Single Micropile, ϕ_{stat}	Side Resistance (Bond Resistance): Presumptive Values	0.55 ⁽¹⁾
	Tip Resistance on Rock O'Neill and Reese (1999)	0.50
	Side Resistance and Tip Resistance Load Test	Values in Table 10.5.5.2.3-1, but no greater than 0.70
Block Failure, ϕ_{bl}	Clay	0.60
Uplift Resistance of Single Micropile, ϕ_{up}	Presumptive Values	0.55 ⁽¹⁾
	Tension Load Test	Values in Table 10.5.5.2.3-1, but no greater than 0.70
Group Uplift Resistance, ϕ_{ug}	Sand & Clay	0.50

⁽¹⁾ Apply to presumptive grout-to-ground bond values for preliminary design only in Article C10.9.3.5.2.

Table 10.5.5.2.5-2—Resistance Factors for Structural Resistance of Axially Loaded Micropiles

Section / Loading Condition		Resistance Factor
Pile Cased Length	Tension, ϕ_{TC}	0.80
	Compression, ϕ_{CC}	0.75
Pile Uncased Length	Tension, ϕ_{TU}	0.80
	Compression, ϕ_{CU}	0.75

10.5.5.3—Extreme Limit States

10.5.5.3.1—General

Design of foundations at extreme limit states shall be consistent with the expectation that structure collapse is prevented and that life safety is protected.

10.5.5.3.2—Scour

The provisions of Articles 2.6.4.4.2 and 3.7.5 shall apply to the changed foundation conditions resulting from scour. Resistance factors at the strength limit state shall be taken as specified herein. Resistance factors at the extreme event shall be taken as 1.0 except that for uplift resistance of piles and shafts, the resistance factor shall be taken as 0.80 or less.

The foundation shall resist not only the loads applied from the structure but also any debris loads occurring during the flood event.

C10.5.5.3.2

The specified resistance factors should be used provided that the method used to compute the nominal resistance does not exhibit bias that is unconservative. See Paikowsky et al. (2004) regarding bias values for pile resistance prediction methods.

Design for scour is discussed in Hannigan et al. (2005).

10.5.5.3.3—Other Extreme Limit States

Resistance factors for extreme limit state, including the design of foundations to resist earthquake, ice, vehicle or vessel impact loads, shall be taken as 1.0. For uplift resistance of piles and shafts, the resistance factor shall be taken as 0.80 or less.

C10.5.5.3.3

The difference between compression skin friction and tension skin friction should be taken into account through the resistance factor, to be consistent with how this is done for the strength limit state (see Article 10.5.5.2.3).

10.6—SPREAD FOOTINGS**10.6.1—General Considerations****10.6.1.1—General**

Provisions of this Article shall apply to design of isolated, continuous strip and combined footings for use in support of columns, walls and other substructure and superstructure elements. Special attention shall be given to footings on fill, to make sure that the quality of the fill placed below the footing is well controlled and of adequate quality in terms of shear strength and compressibility to support the footing loads.

Spread footings shall be proportioned and designed such that the supporting soil or rock provides adequate nominal resistance, considering both the potential for adequate bearing strength and the potential for settlement, under all applicable limit states in accordance with the provisions of this Section.

Spread footings shall be proportioned and located to maintain stability under all applicable limit states, considering the potential for, but not necessarily limited to, overturning (eccentricity), sliding, uplift, overall stability and loss of lateral support.

10.6.1.2—Bearing Depth

Where the potential for scour, erosion or undermining exists, spread footings shall be located to bear below the maximum anticipated depth of scour, erosion, or undermining as specified in Article 2.6.4.4.

C10.6.1.1

Problems with insufficient bearing and/or excessive settlements in fill can be significant, particularly if poor, e.g., soft, wet, frozen, or nondurable, material is used, or if the material is not properly compacted.

Spread footings should not be used on soil or rock conditions that are determined to be too soft or weak to support the design loads without excessive movement or loss of stability. Alternatively, the unsuitable material can be removed and replaced with suitable and properly compacted engineered fill material, or improved in place, at reasonable cost as compared to other foundation support alternatives.

Footings should be proportioned so that the stress under the footing is as nearly uniform as practicable at the service limit state. The distribution of soil stress should be consistent with properties of the soil or rock and the structure and with established principles of soil and rock mechanics.

C10.6.1.2

Consideration should be given to the use of either a geotextile or graded granular filter material to reduce the susceptibility of fine grained material piping into rip rap or open-graded granular foundation material.

For spread footings founded on excavated or blasted rock, attention should be paid to the effect of excavation and/or blasting. Blasting of highly resistant competent rock formations may result in overbreak and fracturing of the rock to some depth below the bearing elevation. Blasting may reduce the resistance to scour within the zone of overbreak or fracturing.

Evaluation of seepage forces and hydraulic gradients should be performed as part of the design of foundations that will extend below the groundwater table. Upward seepage forces in the bottom of excavations can result in piping loss of soil and/or heaving and loss of stability in the base of foundation excavations. Dewatering with wells or wellpoints can control these problems. Dewatering can result in settlement of adjacent ground or structures. If adjacent structures may be damaged by settlement induced by dewatering, seepage cut-off methods such as sheet piling or slurry walls may be necessary.

Spread footings shall be located below the depth of frost potential. Depth of frost potential shall be determined on the basis of local or regional frost penetration data.

10.6.1.3—Effective Footing Dimensions

For eccentrically loaded footings, a reduced effective area, $B' \times L'$, within the confines of the physical footing shall be used in geotechnical design for settlement or bearing resistance. The point of load application shall be at the centroid of the reduced effective area.

The reduced dimensions for an eccentrically loaded rectangular footing shall be taken as:

$$B' = B - 2e_B \quad (10.6.1.3-1)$$

$$L' = L - 2e_L$$

where:

e_B = eccentricity parallel to dimension B (ft)

e_L = eccentricity parallel to dimension L (ft)

Footings under eccentric loads shall be designed to ensure that the factored bearing resistance is not less than the effects of factored loads at all applicable limit states.

For footings that are not rectangular, similar procedures should be used based upon the principles specified above.

10.6.1.4—Bearing Stress Distributions

When proportioning footing dimensions to meet settlement and bearing resistance requirements at all applicable limit states, the distribution of bearing stress on the effective area shall be assumed to be:

- Uniform for footings on soils, or
- Linearly varying, i.e., triangular or trapezoidal as applicable, for footings on rock

The distribution of bearing stress shall be determined as specified in Article 11.6.3.2.

Bearing stress distributions for structural design of the footing shall be as specified in Article 10.6.5.

Consideration may be given to over-excavation of frost susceptible material to below the frost depth and replacement with material that is not frost susceptible.

C10.6.1.3

The reduced dimensions for a rectangular footing are shown in Figure C10.6.1.3-1.

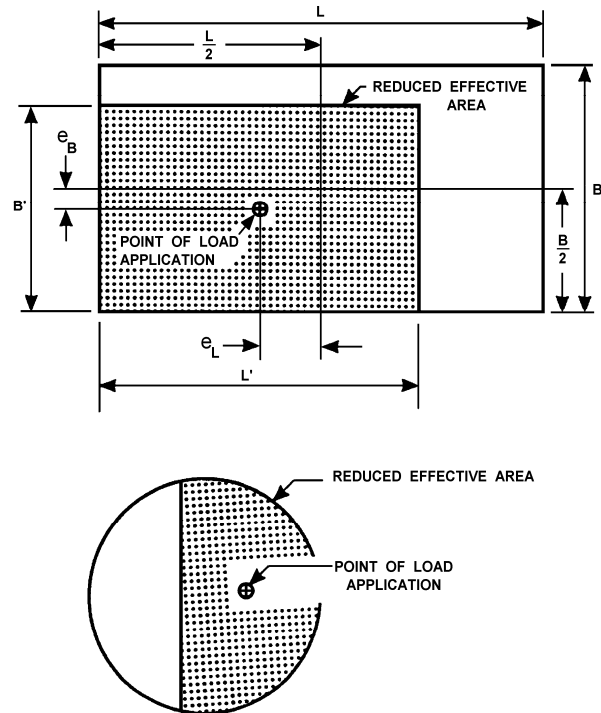

Figure C10.6.1.3-1—Reduced Footing Dimensions

For footings that are not rectangular, such as the circular footing shown in Figure C10.6.1.3-1, the reduced effective area is always concentrically loaded and can be estimated by approximation and judgment. Such an approximation could be made, assuming a reduced rectangular footing size having the same area and centroid as the shaded area of the circular footing shown in Figure C10.6.1.3-1.

10.6.1.5—Anchorage of Inclined Footings

Footings that are founded on inclined smooth solid rock surfaces and that are not restrained by an overburden of resistant material shall be effectively anchored by means of rock anchors, rock bolts, dowels, keys or other suitable means. Shallow keying of large footings shall be avoided where blasting is required for rock removal.

10.6.1.6—Groundwater

Spread footings shall be designed in consideration of the highest anticipated groundwater table.

The influences of groundwater table on the bearing resistance of soils or rock and on the settlement of the structure shall be considered. In cases where seepage forces are present, they should also be included in the analyses.

10.6.1.7—Uplift

Where spread footings are subjected to uplift forces, they shall be investigated both for resistance to uplift and for structural strength.

10.6.1.8—Nearby Structures

Where foundations are placed adjacent to existing structures, the influence of the existing structure on the behavior of the foundation and the effect of the foundation on the existing structures shall be investigated.

10.6.2—Service Limit State Design**10.6.2.1—General**

Service limit state design of spread footings shall include evaluation of total and differential settlement and overall stability. Overall stability of a footing shall be evaluated where one or more of the following conditions exist:

- Horizontal or inclined loads are present,
- The foundation is placed on embankment,
- The footing is located on, near or within a slope,
- The possibility of loss of foundation support through erosion or scour exists, or
- Bearing strata are significantly inclined.

10.6.2.2—Tolerable Movements

The requirements of Article 10.5.2.1 shall apply.

C10.6.1.5

Design of anchorages should include consideration of corrosion potential and protection.

C10.6.2.1

The design of spread footings is frequently controlled by movement at the service limit state. It is therefore usually advantageous to proportion spread footings at the service limit state and check for adequate design at the strength and extreme limit states.

10.6.2.3—Loads

Immediate settlement shall be determined using load combination Service I, as specified in Table 3.4.1-1. Time-dependent settlements in cohesive soils should be determined using only the permanent loads, i.e., transient loads should not be considered.

10.6.2.4—Settlement Analyses*10.6.2.4.1—General*

Foundation settlements should be estimated using computational methods based on the results of laboratory or insitu testing, or both. The soil parameters used in the computations should be chosen to reflect the loading history of the ground, the construction sequence, and the effects of soil layering.

Both total and differential settlements, including time dependant effects, shall be considered.

Total settlement, including elastic, consolidation, and secondary components may be taken as:

$$S_t = S_e + S_c + S_s \quad (10.6.2.4.1-1)$$

where:

S_e = elastic settlement (ft)

S_c = primary consolidation settlement (ft)

S_s = secondary settlement (ft)

C10.6.2.3

The type of load or the load characteristics may have a significant effect on spread footing deformation. The following factors should be considered in the estimation of footing deformation:

- The ratio of sustained load to total load,
- The duration of sustained loads, and
- The time interval over which settlement or lateral displacement occurs.

The consolidation settlements in cohesive soils are time-dependent; consequently, transient loads have negligible effect. However, in cohesionless soils where the permeability is sufficiently high, elastic deformation of the supporting soil due to transient load can take place. Because deformation in cohesionless soils often takes place during construction while the loads are being applied, it can be accommodated by the structure to an extent, depending on the type of structure and construction method.

Deformation in cohesionless, or granular, soils often occurs as soon as loads are applied. As a consequence, settlements due to transient loads may be significant in cohesionless soils, and they should be included in settlement analyses.

C10.6.2.4.1

Elastic, or immediate, settlement is the instantaneous deformation of the soil mass that occurs as the soil is loaded. The magnitude of elastic settlement is estimated as a function of the applied stress beneath a footing or embankment. Elastic settlement is usually small and neglected in design, but where settlement is critical, it is the most important deformation consideration in cohesionless soil deposits and for footings bearing on rock. For footings located on over-consolidated clays, the magnitude of elastic settlement is not necessarily small and should be checked.

In a nearly saturated or saturated cohesive soil, the pore water pressure initially carries the applied stress. As pore water is forced from the voids in the soil by the applied load, the load is transferred to the soil skeleton. Consolidation settlement is the gradual compression of the soil skeleton as the pore water is forced from the voids in the soil. Consolidation settlement is the most important deformation consideration in cohesive soil deposits that possess sufficient strength to safely support a spread footing. While consolidation settlement can occur in saturated cohesionless soils, the consolidation occurs quickly and is normally not distinguishable from the elastic settlement.

Secondary settlement, or creep, occurs as a result of the plastic deformation of the soil skeleton under a constant effective stress. Secondary settlement is of principal concern in highly plastic or organic soil deposits. Such deposits are normally so obviously weak and soft as to preclude consideration of bearing a spread footing on such materials.

The principal deformation component for footings on rock is elastic settlement, unless the rock or included discontinuities exhibit noticeable time-dependent behavior.

For guidance on vertical stress distribution for complex footing geometries, see Poulos and Davis (1974) or Lambe and Whitman (1969).

Some methods used for estimating settlement of footings on sand include an integral method to account for the effects of vertical stress increase variations. For guidance regarding application of these procedures, see Gifford et al. (1987).

The effects of the zone of stress influence, or vertical stress distribution, beneath a footing shall be considered in estimating the settlement of the footing.

Spread footings bearing on a layered profile consisting of a combination of cohesive soil, cohesionless soil and/or rock shall be evaluated using an appropriate settlement estimation procedure for each layer within the zone of influence of induced stress beneath the footing.

The distribution of vertical stress increase below circular or square and long rectangular footings, i.e., where $L > 5B$, may be estimated using Figure 10.6.2.4.1-1.

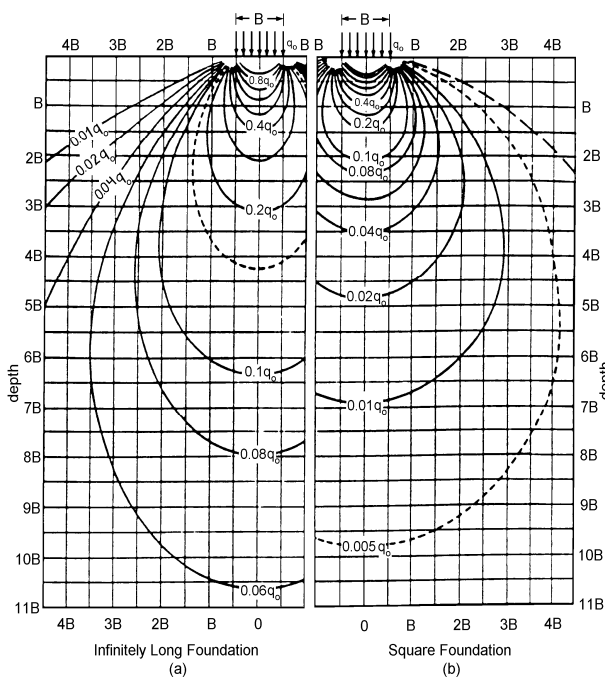

Figure 10.6.2.4.1-1—Boussinesq Vertical Stress Contours for Continuous and Square Footings Modified after Sowers (1979)

10.6.2.4.2—Settlement of Footings on Cohesionless Soils

The settlement of spread footings bearing on cohesionless soil deposits shall be estimated as a function of effective footing width and shall consider the effects of footing geometry and soil and rock layering with depth.

C10.6.2.4.2

Although methods are recommended for the determination of settlement of cohesionless soils, experience has indicated that settlements can vary considerably in a construction site, and this variation may not be predicted by conventional calculations.

Settlements of footings on cohesionless soils shall be estimated using elastic theory or empirical procedures.

Settlements of cohesionless soils occur rapidly, essentially as soon as the foundation is loaded. Therefore, the total settlement under the service loads may not be as important as the incremental settlement between intermediate load stages. For example, the total and differential settlement due to loads applied by columns and cross beams is generally less important than the total and differential settlements due to girder placement and casting of continuous concrete decks.

Generally conservative settlement estimates may be obtained using the elastic half-space procedure or the empirical method by Hough. Additional information regarding the accuracy of the methods described herein is provided in Gifford et al. (1987) and Kimmerling (2002). This information, in combination with local experience and engineering judgment, should be used when determining the estimated settlement for a structure foundation, as there may be cases, such as attempting to build a structure grade high to account for the estimated settlement, when overestimating the settlement magnitude could be problematic.

Details of other procedures can be found in textbooks and engineering manuals, including:

- Terzaghi and Peck (1967)
- Sowers (1979)
- U.S. Department of the Navy (1982)
- D'Appolonia (Gifford et al., 1987)—This method includes consideration for over-consolidated sands.
- Tomlinson (1986)
- Gifford et al. (1987)

The elastic half-space method assumes the footing is flexible and is supported on a homogeneous soil of infinite depth. The elastic settlement of spread footings, in feet, by the elastic half-space method shall be estimated as:

$$S_e = \frac{\left[q_o (1 - \nu^2) \sqrt{A'} \right]}{144 E_s \beta_z} \quad (10.6.2.4.2-1)$$

where:

q_o = applied vertical stress (ksf)

A' = effective area of footing (ft²)

E_s = Young's modulus of soil taken as specified in Article 10.4.6.3 if direct measurements of E_s are not available from the results of in situ or laboratory tests (ksi)

For general guidance regarding the estimation of elastic settlement of footings on sand, see Gifford et al. (1987) and Kimmerling (2002).

The stress distributions used to calculate elastic settlement assume the footing is flexible and supported on a homogeneous soil of infinite depth. The settlement below a flexible footing varies from a maximum near the center to a minimum at the edge equal to about 50 percent and 64 percent of the maximum for rectangular and circular footings, respectively. The settlement profile for rigid footings is assumed to be uniform across the width of the footing.

Spread footings of the dimensions normally used for bridges are generally assumed to be rigid, although the actual performance will be somewhere between perfectly rigid and perfectly flexible, even for relatively thick concrete footings, due to stress redistribution and concrete creep.

The accuracy of settlement estimates using elastic theory are strongly affected by the selection of soil modulus and the inherent assumptions of infinite elastic half space. Accurate estimates of soil moduli are difficult to obtain because the analyses are based on

β_z = shape factor taken as specified in Table 10.6.2.4.2-1 (dim)

ν = Poisson's Ratio, taken as specified in Article 10.4.6.3 if direct measurements of ν are not available from the results of in situ or laboratory tests (dim)

Unless E_s varies significantly with depth, E_s should be determined at a depth of about 1/2 to 2/3 of B below the footing, where B is the footing width. If the soil modulus varies significantly with depth, a weighted average value of E_s should be used.

Table 10.6.2.4.2-1—Elastic Shape and Rigidity Factors, EPRI (1983)

L/B	Flexible, β_z (average)	β_z Rigid
Circular	1.04	1.13
1	1.06	1.08
2	1.09	1.10
3	1.13	1.15
5	1.22	1.24
10	1.41	1.41

Estimation of spread footing settlement on cohesionless soils by the empirical Hough method shall be determined using Eqs. 10.6.2.4.2-2 and 10.6.2.4.2-3. *SPT* blow counts shall be corrected as specified in Article 10.4.6.2.4 for depth, i.e. overburden stress, before correlating the *SPT* blow counts to the bearing capacity index, C' .

$$S_e = \sum_{i=1}^n \Delta H_i \quad (10.6.2.4.2-2)$$

in which:

$$\Delta H_i = H_c \frac{1}{C'} \log \left(\frac{\sigma'_o + \Delta \sigma_v}{\sigma'_o} \right) \quad (10.6.2.4.2-3)$$

where:

n = number of soil layers within zone of stress influence of the footing

ΔH_i = elastic settlement of layer i (ft)

H_c = initial height of layer i (ft)

C' = bearing capacity index from Figure 10.6.2.4.2-1 (dim)

In Figure 10.5.2.4.2-1, N' shall be taken as N_{I60} , Standard Penetration Resistance, N (blows/ft), corrected for overburden pressure as specified in Article 10.4.6.2.4.

only a single value of soil modulus, and Young's modulus varies with depth as a function of overburden stress. Therefore, in selecting an appropriate value for soil modulus, consideration should be given to the influence of soil layering, bedrock at a shallow depth, and adjacent footings.

For footings with eccentric loads, the area, A' , should be computed based on reduced footing dimensions as specified in Article 10.6.1.3.

The Hough method was developed for normally consolidated cohesionless soils.

The Hough method has several advantages over other methods used to estimate settlement in cohesionless soil deposits, including express consideration of soil layering and the zone of stress influence beneath a footing of finite size.

The subsurface soil profile should be subdivided into layers based on stratigraphy to a depth of about three times the footing width. The maximum layer thickness should be about 10 ft.

While Cheney and Chassie (2000), and Hough (1959), did not specifically state that the *SPT* N values should be corrected for hammer energy in addition to overburden pressure, due to the vintage of the original work, hammers that typically have an efficiency of approximately 60 percent were in general used to develop the empirical correlations contained in the method. If using *SPT* hammers with efficiencies that differ significantly from this 60 percent value, the N values should also be corrected for hammer energy, in effect requiring that N_{I60} be used.

σ'_o = initial vertical effective stress at the midpoint of layer i (ksf)

$\Delta\sigma_v$ = increase in vertical stress at the midpoint of layer i (ksf)

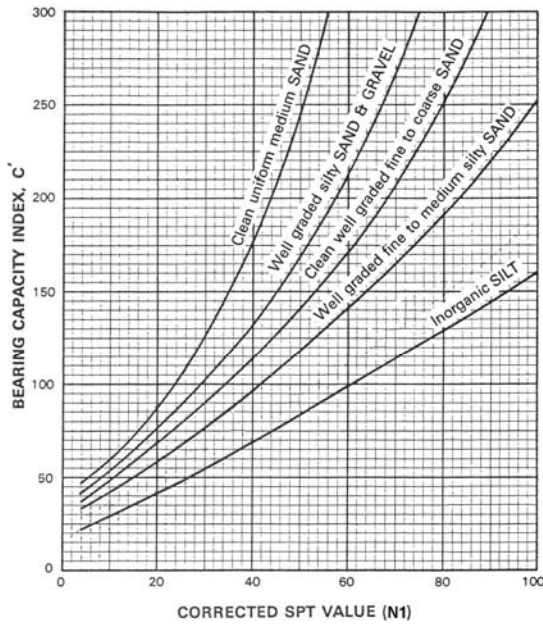

Reference: Hough, "Compressibility as a Basis for Soil Bearing Value" ASCE 1959

Figure 10.6.2.4.2-1—Bearing Capacity Index versus Corrected SPT (modified from Cheney and Chassie, 2000, after Hough, 1959)

10.6.2.4.3—Settlement of Footings on Cohesive Soils

Spread footings in which cohesive soils are located within the zone of stress influence shall be investigated for consolidation settlement. Elastic and secondary settlement shall also be investigated in consideration of the timing and sequence of construction loading and the tolerance of the structure to total and differential movements.

Where laboratory test results are expressed in terms of void ratio, e , the consolidation settlement of footings shall be taken as:

- For overconsolidated soils where $\sigma'_p > \sigma'_o$, see Figure 10.6.2.4.3-1:

$$S_c = \left[\frac{H_c}{1 + e_o} \right] \left[C_r \log \left(\frac{\sigma'_p}{\sigma'_o} \right) + C_c \log \left(\frac{\sigma'_f}{\sigma'_p} \right) \right] \tag{10.6.2.4.3-1}$$

- For normally consolidated soils where $\sigma'_p = \sigma'_o$:

The Hough method is applicable to cohesionless soil deposits. The “Inorganic Silt” curve should generally not be applied to soils that exhibit plasticity. The settlement characteristics of cohesive soils that exhibit plasticity should be investigated using undisturbed samples and laboratory consolidation tests as prescribed in Article 10.6.2.4.3.

C10.6.2.4.3

In practice, footings on cohesive soils are most likely founded on overconsolidated clays, and settlements can be estimated using elastic theory (Baguelin et al., 1978), or the tangent modulus method (Janbu, 1963, 1967). Settlements of footings on overconsolidated clay usually occur at approximately one order of magnitude faster than soils without preconsolidation, and it is reasonable to assume that they take place as rapidly as the loads are applied. Infrequently, a layer of cohesive soil may exhibit a preconsolidation stress less than the calculated existing overburden stress. The soil is then said to be underconsolidated because a state of equilibrium has not yet been reached under the applied overburden stress. Such a condition may have been caused by a recent lowering of the groundwater table. In this case, consolidation settlement will occur due to the additional load of the structure and the settlement that is occurring to reach a state of equilibrium. The total consolidation settlement due to these two components can be estimated by Eq. 10.6.2.4.3-3 or Eq. 10.6.2.4.3-6.

$$S_c = \left[\frac{H_c}{1 + e_o} \right] \left[\left(C_c \log \frac{\sigma'_f}{\sigma'_p} \right) \right] \quad (10.6.2.4.3-2)$$

- For underconsolidated soils where $\sigma'_p < \sigma'_o$:

$$S_c = \left[\frac{H_c}{1 + e_o} \right] \left[C_c \log \left(\frac{\sigma'_f}{\sigma'_{pc}} \right) \right] \quad (10.6.2.4.3-3)$$

Where laboratory test results are expressed in terms of vertical strain, ϵ_v , the consolidation settlement of footings shall be taken as:

- For overconsolidated soils where $\sigma'_p > \sigma'_o$, see Figure 10.6.2.4.3-2:

$$S_c = H_c \left[C_{re} \log \left(\frac{\sigma'_p}{\sigma'_o} \right) + C_{ce} \log \left(\frac{\sigma'_f}{\sigma'_p} \right) \right] \quad (10.6.2.4.3-4)$$

- For normally consolidated soils where $\sigma'_p = \sigma'_o$:

$$S_c = H_c C_{ce} \log \left(\frac{\sigma'_f}{\sigma'_p} \right) \quad (10.6.2.4.3-5)$$

- For underconsolidated soils where $\sigma'_p < \sigma'_o$:

$$S_c = H_c C_{ce} \log \left(\frac{\sigma'_f}{\sigma'_{pc}} \right) \quad (10.6.2.4.3-6)$$

where:

H_c = initial height of compressible soil layer (ft)

e_o = void ratio at initial vertical effective stress (dim)

C_r = recompression index (dim)

C_c = compression index (dim)

C_{re} = recompression ratio (dim)

C_{ce} = compression ratio (dim)

σ'_p = maximum past vertical effective stress in soil at midpoint of soil layer under consideration (ksf)

σ'_o = initial vertical effective stress in soil at midpoint of soil layer under consideration (ksf)

Normally consolidated and underconsolidated soils should be considered unsuitable for direct support of spread footings due to the magnitude of potential settlement, the time required for settlement, for low shear strength concerns, or any combination of these design considerations. Preloading or vertical drains may be considered to mitigate these concerns.

To account for the decreasing stress with increased depth below a footing and variations in soil compressibility with depth, the compressible layer should be divided into vertical increments, i.e., typically 5.0 to 10.0 ft for most normal width footings for highway applications, and the consolidation settlement of each increment analyzed separately. The total value of S_c is the summation of S_c for each increment.

The magnitude of consolidation settlement depends on the consolidation properties of the soil. These properties include the compression and recompression constants, C_c and C_r , or C_{ce} and C_{re} ; the preconsolidation stress, σ'_p ; the current, initial vertical effective stress, σ'_o ; and the final vertical effective stress after application of additional loading, σ'_f . An overconsolidated soil has been subjected to larger stresses in the past than at present. This could be a result of preloading by previously overlying strata, desiccation, groundwater lowering, glacial overriding or an engineered preload. If $\sigma'_o = \sigma'_p$, the soil is normally consolidated. Because the recompression constant is typically about an order of magnitude smaller than the compression constant, an accurate determination of the preconsolidation stress, σ'_p , is needed to make reliable estimates of consolidation settlement.

The reliability of consolidation settlement estimates is also affected by the quality of the consolidation test sample and by the accuracy with which changes in σ'_p with depth are known or estimated. As shown in Figure C10.6.2.4.3-1, the slope of the e or ϵ_v versus $\log \sigma'_v$ curve and the location of σ'_p can be strongly affected by the quality of samples used for the laboratory consolidation tests. In general, the use of poor quality samples will result in an overestimate of consolidation settlement. Typically, the value of σ'_p will vary with depth as shown in Figure C10.6.2.4.3-2. If the variation of σ'_p with depth is unknown, e.g., only one consolidation test was conducted in the soil profile, actual settlements could be higher or lower than the computed value based on a single value of σ'_p .

The cone penetrometer test may be used to improve understanding of both soil layering and variation of σ'_p with depth by correlation to laboratory tests from discrete locations.

σ'_f = final vertical effective stress in soil at midpoint of soil layer under consideration (ksf)

σ'_{pc} = current vertical effective stress in soil, not including the additional stress due to the footing loads, at midpoint of soil layer under consideration (ksf)

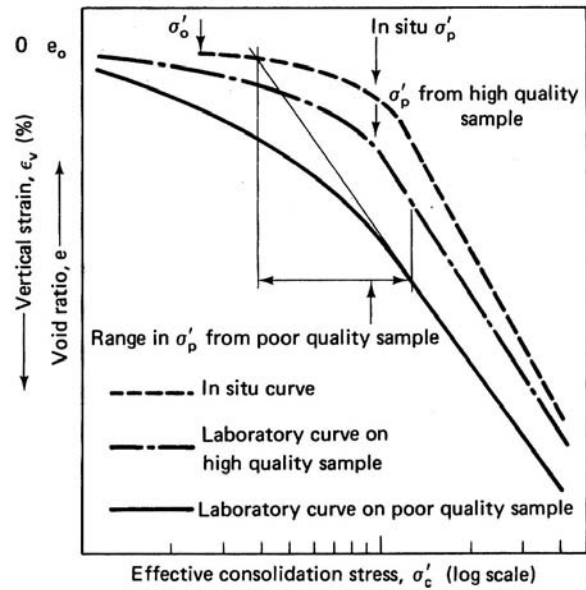

Figure C10.6.2.4.3-1—Effects of Sample Quality on Consolidation Test Results, Holtz and Kovacs (1981)

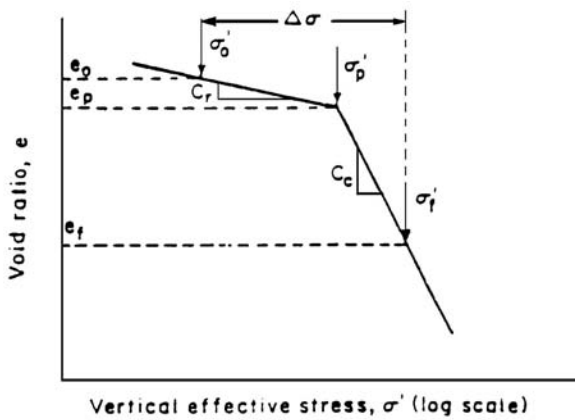

Figure 10.6.2.4.3-1—Typical Consolidation Compression Curve for Overconsolidated Soil: Void Ratio versus Vertical Effective Stress, EPRI (1983)

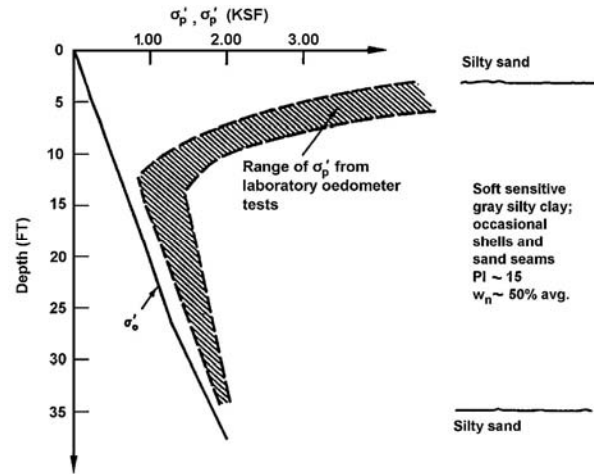

Figure C10.6.2.4.3-2—Typical Variation of Preconsolidation Stress with Depth, Holtz and Kovacs (1981)

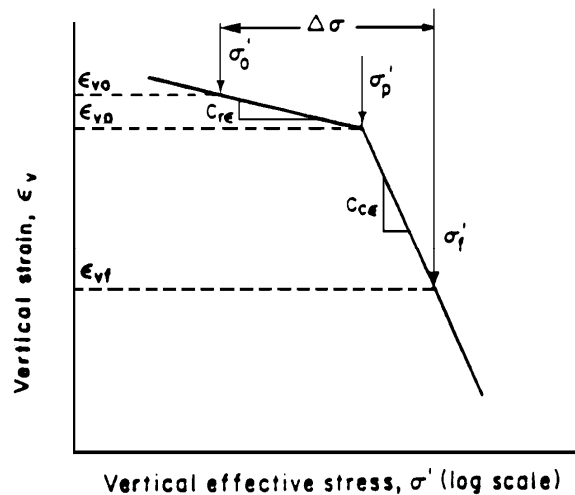

Figure 10.6.2.4.3-2—Typical Consolidation Compression Curve for Overconsolidated Soil: Vertical Strain versus Vertical Effective Stress, EPRI (1983)

If the footing width, B , is small relative to the thickness of the compressible soil, H_c , the effect of three-dimensional loading shall be considered and shall be taken as:

$$S_{c(3-D)} = \mu_c S_{c(1-D)} \quad (10.6.2.4.3-7)$$

where:

μ_c = reduction factor taken as specified in Figure 10.6.2.4.3-3 (dim)

$S_{c(1-D)}$ = single dimensional consolidation settlement (ft)

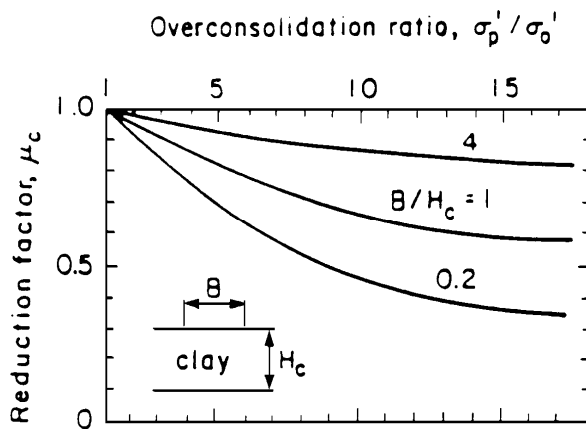

Figure 10.6.2.4.3-3—Reduction Factor to Account for Effects of Three-Dimensional Consolidation Settlement (EPRI, 1983)

The time, t , to achieve a given percentage of the total estimated one-dimensional consolidation settlement shall be taken as:

$$t = \frac{TH_d^2}{c_v} \quad (10.6.2.4.3-8)$$

where:

T = time factor taken as specified in Figure 10.6.2.4.3-4 for the excess pore pressure distributions shown in the Figure (dim)

H_d = length of longest drainage path in compressible layer under consideration (ft)

c_v = coefficient of consolidation (ft^2/yr)

Consolidation occurs when a saturated compressible layer of soil is loaded and water is squeezed out of the layer. The time required for the (primary) consolidation process to end will depend on the permeability of the soil. Because the time factor, T , is defined as logarithmic, the consolidation process theoretically never ends. The practical assumption is usually made that the additional consolidation past 90 percent or 95 percent consolidation is negligible, or is taken into consideration as part of the total long term settlement.

Refer to Winterkorn and Fang (1975) for values of T for excess pore pressure distributions other than indicated in Figure 10.6.2.4.3-4.

The length of the drainage path is the longest distance from any point in a compressible layer to a drainage boundary at the top or bottom of the compressible soil unit. Where a compressible layer is located between two drainage boundaries, H_d equals one-half the actual height of the layer. Where a compressible layer is adjacent to an impermeable boundary (usually below), H_d equals the full height of the layer.

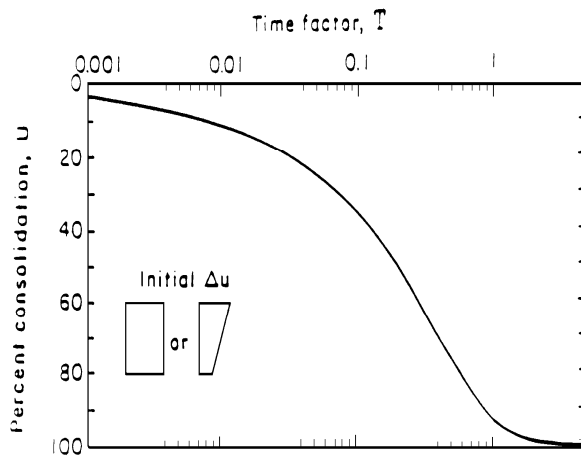

Figure 10.6.2.4.3-4 Percentage of Consolidation as a Function of Time Factor, T (EPRI, 1983)

Where laboratory test results are expressed in terms of void ratio, e , the secondary settlement of footings on cohesive soil shall be taken as:

$$S_s = \frac{C_a}{1 + e_o} H_c \log \left(\frac{t_2}{t_1} \right) \quad (10.6.2.4.3-9)$$

Where laboratory test results are expressed in terms of vertical strain, ϵ_v , the secondary settlement of footings on cohesive soils shall be taken as:

$$S_s = C_{ae} H_c \log \left(\frac{t_2}{t_1} \right) \quad (10.6.2.4.3-10)$$

where:

H_c = initial height of compressible soil layer (ft)

e_o = void ratio at initial vertical effective stress (dim)

t_1 = time when secondary settlement begins, i.e., typically at a time equivalent to 90 percent average degree of primary consolidation (yr)

t_2 = arbitrary time that could represent the service life of the structure (yr)

Computations to predict the time rate of consolidation based on the result of laboratory tests generally tend to over-estimate the actual time required for consolidation in the field. This over-estimation is principally due to:

- The presence of thin drainage layers within the compressible layer that are not observed from the subsurface exploration nor considered in the settlement computations,
- The effects of three-dimensional dissipation of pore water pressures in the field, rather than the one-dimensional dissipation that is imposed by laboratory odometer tests and assumed in the computations, and
- The effects of sample disturbance, which tend to reduce the permeability of the laboratory tested samples.

If the total consolidation settlement is within the serviceability limits for the structure, the time rate of consolidation is usually of lesser concern for spread footings. If the total consolidation settlement exceeds the serviceability limitations, superstructure damage will occur unless provisions are made for timing of closure pours as a function of settlement, simple support of spans and/or periodic jacking of bearing supports.

Secondary compression component if settlement results from compression of bonds between individual clay particles and domains, as well as other effects on the microscale that are not yet clearly understood (Holtz and Kovacs, 1981). Secondary settlement is most important for highly plastic clays and organic and micaceous soils. Accordingly, secondary settlement predictions should be considered as approximate estimates only.

If secondary compression is estimated to exceed serviceability limitations, either deep foundations or ground improvement should be considered to mitigate the effects of secondary compression. Experience indicates preloading and surcharging may not be effective in eliminating secondary compression.

C_α = secondary compression index estimated from the results of laboratory consolidation testing of undisturbed soil samples (dim)

$C_{\alpha e}$ = modified secondary compression index estimated from the results of laboratory consolidation testing of undisturbed soil samples (dim)

10.6.2.4.4—Settlement of Footings on Rock

For footings bearing on fair to very good rock, according to the Geomechanics Classification system, as defined in Article 10.4.6.4, and designed in accordance with the provisions of this Section, elastic settlements may generally be assumed to be less than 0.5 in. When elastic settlements of this magnitude are unacceptable or when the rock is not competent, an analysis of settlement based on rock mass characteristics shall be made.

Where rock is broken or jointed (relative rating of ten or less for RQD and joint spacing), the rock joint condition is poor (relative rating of ten or less) or the criteria for fair to very good rock are not met, a settlement analysis should be conducted, and the influence of rock type, condition of discontinuities, and degree of weathering shall be considered in the settlement analysis.

The elastic settlement of footings on broken or jointed rock, in feet, should be taken as:

- For circular (or square) footings:

$$\rho = q_o (1 - \nu^2) \frac{r I_p}{144 E_m} \quad (10.6.2.4.4-1)$$

in which:

$$I_p = \frac{(\sqrt{\pi})}{\beta_z} \quad (10.6.2.4.4-2)$$

- For rectangular footings:

$$\rho = q_o (1 - \nu^2) \frac{B I_p}{144 E_m} \quad (10.6.2.4.4-3)$$

in which:

$$I_p = \frac{(L/B)^{1/2}}{\beta_z} \quad (10.6.2.4.4-4)$$

C10.6.2.4.4

In most cases, it is sufficient to determine settlement using the average bearing stress under the footing.

Where the foundations are subjected to a very large load or where settlement tolerance may be small, settlements of footings on rock may be estimated using elastic theory. The stiffness of the rock mass should be used in such analyses.

The accuracy with which settlements can be estimated by using elastic theory is dependent on the accuracy of the estimated rock mass modulus, E_m . In some cases, the value of E_m can be estimated through empirical correlation with the value of the modulus of elasticity for the intact rock between joints. For unusual or poor rock mass conditions, it may be necessary to determine the modulus from in-situ tests, such as plate loading and pressuremeter tests.

where:

q_o = applied vertical stress at base of loaded area (ksf)

ν = Poisson's Ratio (dim)

r = radius of circular footing or $B/2$ for square footing (ft)

I_p = influence coefficient to account for rigidity and dimensions of footing (dim)

E_m = rock mass modulus (ksi)

β_z = factor to account for footing shape and rigidity (dim)

Values of I_p should be computed using the β_z values presented in Table 10.6.2.4.2-1 for rigid footings. Where the results of laboratory testing are not available, values of Poisson's ratio, ν , for typical rock types may be taken as specified in Table C10.4.6.5-2. Determination of the rock mass modulus, E_m , should be based on the methods described in Article 10.4.6.5.

The magnitude of consolidation and secondary settlements in rock masses containing soft seams or other material with time-dependent settlement characteristics should be estimated by applying procedures specified in Article 10.6.2.4.3.

10.6.2.5—Overall Stability

Overall stability of spread footings shall be investigated using Service I Load Combination and the provisions of Articles 3.4.1, 10.5.2.3, and 11.6.3.4.

10.6.2.6—Bearing Resistance at the Service Limit State

10.6.2.6.1—Presumptive Values for Bearing Resistance

C10.6.2.6.1

The use of presumptive values shall be based on knowledge of geological conditions at or near the structure site.

Unless more appropriate regional data are available, the presumptive values given in Table C10.6.2.6.1-1 may be used. These bearing resistances are settlement limited, e.g., 1.0 in., and apply only at the service limit state.

Table C10.6.2.6.1-1—Presumptive Bearing Resistance for Spread Footing Foundations at the Service Limit State Modified after U.S. Department of the Navy (1982)

Type of Bearing Material	Consistency in Place	Bearing Resistance (ksf)	
		Ordinary Range	Recommended Value of Use
Massive crystalline igneous and metamorphic rock: granite, diorite, basalt, gneiss, thoroughly cemented conglomerate (sound condition allows minor cracks)	Very hard, sound rock	120–200	160
Foliated metamorphic rock: slate, schist (sound condition allows minor cracks)	Hard sound rock	60–80	70
Sedimentary rock: hard cemented shales, siltstone, sandstone, limestone without cavities	Hard sound rock	30–50	40
Weathered or broken bedrock of any kind, except highly argillaceous rock (shale)	Medium hard rock	16–24	20
Compaction shale or other highly argillaceous rock in sound condition	Medium hard rock	16–24	20
Well-graded mixture of fine- and coarse-grained soil: glacial till, hardpan, boulder clay (GW-GC, GC, SC)	Very dense	16–24	20
Gravel, gravel-sand mixture, boulder-gravel mixtures (GW, GP, SW, SP)	Very dense	12–20	14
	Medium dense to dense	8–14	10
	Loose	4–12	6
Coarse to medium sand, and with little gravel (SW, SP)	Very dense	8–12	8
	Medium dense to dense	4–8	6
	Loose	2–6	3
Fine to medium sand, silty or clayey medium to coarse sand (SW, SM, SC)	Very dense	6–10	6
	Medium dense to dense	4–8	5
	Loose	2–4	3
Fine sand, silty or clayey medium to fine sand (SP, SM, SC)	Very dense	6–10	6
	Medium dense to dense	4–8	5
	Loose	2–4	3
Homogeneous inorganic clay, sandy or silty clay (CL, CH)	Very dense	6–12	8
	Medium dense to dense	2–6	4
	Loose	1–2	1
Inorganic silt, sandy or clayey silt, varved silt-clay-fine sand (ML, MH)	Very stiff to hard	4–8	6
	Medium stiff to stiff	2–6	3
	Soft	1–2	1

10.6.2.6.2—Semiempirical Procedures for Bearing Resistance

Bearing resistance on rock shall be determined using empirical correlation to the Geomechanic Rock Mass Rating System, RMR, as specified in Article 10.4.6.4. Local experience should be considered in the use of these semi-empirical procedures.

If the recommended value of presumptive bearing resistance exceeds either the unconfined compressive strength of the rock or the nominal resistance of the concrete, the presumptive bearing resistance shall be taken as the lesser of the unconfined compressive strength of the rock or the nominal resistance of the concrete. The nominal resistance of concrete shall be taken as $0.3 f'_c$.

10.6.3—Strength Limit State Design

10.6.3.1—Bearing Resistance of Soil

10.6.3.1.1—General

Bearing resistance of spread footings shall be determined based on the highest anticipated position of groundwater level at the footing location.

The factored resistance, q_R , at the strength limit state shall be taken as:

$$q_R = \Phi_b q_n \quad (10.6.3.1.1-1)$$

where:

Φ_b = resistance factor specified in Article 10.5.5.2.2

q_n = nominal bearing resistance (ksf)

Where loads are eccentric, the effective footing dimensions, L' and B' , as specified in Article 10.6.1.3, shall be used instead of the overall dimensions L and B in all equations, tables, and figures pertaining to bearing resistance.

C10.6.3.1.1

The bearing resistance of footings on soil should be evaluated using soil shear strength parameters that are representative of the soil shear strength under the loading conditions being analyzed. The bearing resistance of footings supported on granular soils should be evaluated for both permanent dead loading conditions and short-duration live loading conditions using effective stress methods of analysis and drained soil shear strength parameters. The bearing resistance of footings supported on cohesive soils should be evaluated for short-duration live loading conditions using total stress methods of analysis and undrained soil shear strength parameters. In addition, the bearing resistance of footings supported on cohesive soils, which could soften and lose strength with time, should be evaluated for permanent dead loading conditions using effective stress methods of analysis and drained soil shear strength parameters.

The position of the groundwater table can significantly influence the bearing resistance of soils through its effect on shear strength and unit weight of the foundation soils. In general, the submergence of soils will reduce the effective shear strength of cohesionless (or granular) materials, as well as the long-term (or drained) shear strength of cohesive (clayey) soils. Moreover, the effective unit weights of submerged soils are about half of those for the same soils under dry conditions. Thus, submergence may lead to a significant reduction in the bearing resistance provided by the foundation soils, and it is essential that the bearing resistance analyses be carried out under the assumption of the highest groundwater table expected within the service life of the structure.

Footings with inclined bases should be avoided wherever possible. Where use of an inclined footing base cannot be avoided, the nominal bearing resistance determined in accordance with the provisions herein should be further reduced using accepted corrections for inclined footing bases in Munfakh, et al. (2001).

Because the effective dimensions will vary slightly for each limit state under consideration, strict adherence to this provision will require re-computation of the nominal bearing resistance at each limit state.

Further, some of the equations for the bearing resistance modification factors based on L and B were not necessarily or specifically developed with the intention that effective dimensions be used. The designer should ensure that appropriate values of L and B are used, and that effective footing dimensions L' and B' are used appropriately.

Consideration should be given to the relative change in the computed nominal resistance based on effective versus gross footing dimensions for the size of footings typically used for bridges. Judgment should be used in deciding whether the use of gross footing dimensions for computing nominal bearing resistance at the strength limit state would result in a conservative design.

10.6.3.1.2—Theoretical Estimation

10.6.3.1.2a—Basic Formulation

C10.6.3.1.2a

The nominal bearing resistance shall be estimated using accepted soil mechanics theories and should be based on measured soil parameters. The soil parameters used in the analyses shall be representative of the soil shear strength under the considered loading and subsurface conditions.

The nominal bearing resistance of spread footings on cohesionless soils shall be evaluated using effective stress analyses and drained soil strength parameters.

The nominal bearing resistance of spread footings on cohesive soils shall be evaluated for total stress analyses and undrained soil strength parameters. In cases where the cohesive soils may soften and lose strength with time, the bearing resistance of these soils shall also be evaluated for permanent loading conditions using effective stress analyses and drained soil strength parameters.

For spread footings bearing on compacted soils, the nominal bearing resistance shall be evaluated using the more critical of either total or effective stress analyses.

Except as noted below, the nominal bearing resistance of a soil layer, in ksf, should be taken as:

$$q_n = cN_{cm} + \gamma D_f N_{qm} C_{wq} + 0.5\gamma B N_{\gamma m} C_{w\gamma} \quad (10.6.3.1.2a-1)$$

in which:

$$N_{cm} = N_c s_c i_c \quad (10.6.3.1.2a-2)$$

$$N_{qm} = N_q s_q d_q i_q \quad (10.6.3.1.2a-3)$$

$$N_{\gamma m} = N_\gamma s_\gamma i_\gamma \quad (10.6.3.1.2a-4)$$

where:

c = cohesion, taken as undrained shear strength (ksf)

N_c = cohesion term (undrained loading) bearing capacity factor as specified in Table 10.6.3.1.2a-1 (dim)

The bearing resistance formulation provided in Eqs. 10.6.3.1.2a-1 through 10.6.3.1.2a-4 is the complete formulation as described in the Munfakh, et al. (2001). However, in practice, not all of the factors included in these equations have been routinely used.

- N_q = surcharge (embedment) term (drained or undrained loading) bearing capacity factor as specified in Table 10.6.3.1.2a-1 (dim)
- N_γ = unit weight (footing width) term (drained loading) bearing capacity factor as specified in Table 10.6.3.1.2a-1 (dim)
- γ = total (moist) unit weight of soil above or below the bearing depth of the footing (kef)
- D_f = footing embedment depth (ft)
- B = footing width (ft)
- $C_{wq}, C_{w\gamma}$ = correction factors to account for the location of the groundwater table as specified in Table 10.6.3.1.2a-2 (dim)
- s_c, s_γ, s_q = footing shape correction factors as specified in Table 10.6.3.1.2a-3 (dim)
- d_q = correction factor to account for the shearing resistance along the failure surface passing through cohesionless material above the bearing elevation as specified in Table 10.6.3.1.2a-4 (dim)
- i_c, i_γ, i_q = load inclination factors determined from Eqs. 10.6.3.1.2a-5 or 10.6.3.1.2a-6, and 10.6.3.1.2a-7 and 10.6.3.1.2a-8 (dim)

For $\phi_f = 0$:

$$i_c = 1 - (mH/cBLN_c) \quad (10.6.3.1.2a-5)$$

For $\phi_f > 0$:

$$i_c = i_q - [(1 - i_q)/(N_q - 1)] \quad (10.6.3.1.2a-6)$$

in which:

$$i_q = \left[1 - \frac{H}{(V + cBL \cot \phi_f)} \right]^n \quad (10.6.3.1.2a-7)$$

$$i_\gamma = \left[1 - \frac{H}{V + cBL \cot \phi_f} \right]^{(n+1)} \quad (10.6.3.1.2a-8)$$

$$n = [(2 + L/B)/(1 + L/B)] \cos^2 \theta + [(2 + B/L)/(1 + B/L)] \sin^2 \theta \quad (10.6.3.1.2a-9)$$

Most geotechnical engineers nationwide have not used the load inclination factors. This is due, in part, to the lack of knowledge of the vertical and horizontal loads at the time of geotechnical explorations and preparation of bearing resistance recommendations.

Furthermore, the basis of the load inclination factors computed by Eqs. 10.6.3.1.2a-5 to 10.6.3.1.2a-8 is a combination of bearing resistance theory and small scale load tests on 1 in. wide plates on London Clay and Ham River Sand (Meyerhof, 1953). Therefore, the factors do not take into consideration the effects of depth of embedment. Meyerhof further showed that for footings with a depth of embedment ratio of $D_f/B = 1$, the effects of load inclination on bearing resistance are relatively small. The theoretical formulation of load inclination factors were further examined by Brinch-Hansen (1970), with additional modification by Vesic (1973) into the form provided in Eqs. 10.6.3.1.2a-5 to 10.6.3.1.2a-8.

It should further be noted that the resistance factors provided in Article 10.5.5.2.2 were derived for vertical loads. The applicability of these resistance factors to design of footings resisting inclined load combinations is not currently known. The combination of the resistance factors and the load inclination factors may be overly conservative for footings with an embedment of approximately $D_f/B = 1$ or deeper because the load inclination factors were derived for footings without embedment.

where:

B = footing width (ft)

L = footing length (ft)

H = unfactored horizontal load (kips)

V = unfactored vertical load (kips)

θ = projected direction of load in the plane of the footing, measured from the side of length L (degrees)

In practice, therefore, for footings with modest embedment, consideration may be given to omission of the load inclination factors.

Figure C10.6.3.1.2a-1 shows the convention for determining the θ angle in Eq. 10.6.3.1.2a-9.

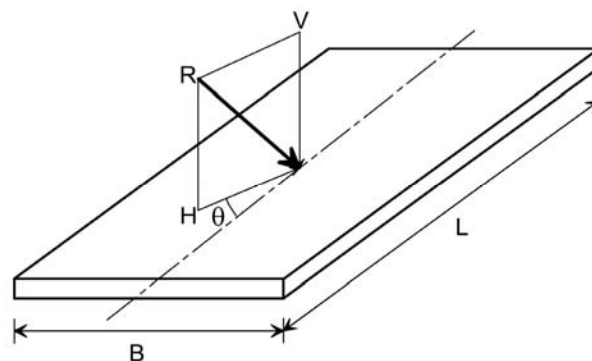

Figure C10.6.3.1.2a-1—Inclined Loading Conventions

Table 10.6.3.1.2a-1—Bearing Capacity Factors N_c (Prandtl, 1921), N_q (Reissner, 1924), and N_γ (Vesic, 1975)

ϕ_f	N_c	N_q	N_γ	ϕ_f	N_c	N_q	N_γ
0	5.14	1.0	0.0	23	18.1	8.7	8.2
1	5.4	1.1	0.1	24	19.3	9.6	9.4
2	5.6	1.2	0.2	25	20.7	10.7	10.9
3	5.9	1.3	0.2	26	22.3	11.9	12.5
4	6.2	1.4	0.3	27	23.9	13.2	14.5
5	6.5	1.6	0.5	28	25.8	14.7	16.7
6	6.8	1.7	0.6	29	27.9	16.4	19.3
7	7.2	1.9	0.7	30	30.1	18.4	22.4
8	7.5	2.1	0.9	31	32.7	20.6	26.0
9	7.9	2.3	1.0	32	35.5	23.2	30.2
10	8.4	2.5	1.2	33	38.6	26.1	35.2
11	8.8	2.7	1.4	34	42.2	29.4	41.1
12	9.3	3.0	1.7	35	46.1	33.3	48.0
13	9.8	3.3	2.0	36	50.6	37.8	56.3
14	10.4	3.6	2.3	37	55.6	42.9	66.2
15	11.0	3.9	2.7	38	61.4	48.9	78.0
16	11.6	4.3	3.1	39	67.9	56.0	92.3
17	12.3	4.8	3.5	40	75.3	64.2	109.4
18	13.1	5.3	4.1	41	83.9	73.9	130.2
19	13.9	5.8	4.7	42	93.7	85.4	155.6
20	14.8	6.4	5.4	43	105.1	99.0	186.5
21	15.8	7.1	6.2	44	118.4	115.3	224.6
22	16.9	7.8	7.1	45	133.9	134.9	271.8

Table 10.6.3.1.2a-2—Coefficients C_{wq} and C_{wy} for Various Groundwater Depths

D_w	C_{wq}	C_{wy}
0.0	0.5	0.5
D_f	1.0	0.5
$>1.5B + D_f$	1.0	1.0

Where the position of groundwater is at a depth less than 1.5 times the footing width below the footing base, the bearing resistance is affected. The highest anticipated groundwater level should be used in design.

Table 10.6.3.1.2a-3—Shape Correction Factors s_c, s_γ, s_q

Factor	Friction Angle	Cohesion Term (s_c)	Unit Weight Term (s_γ)	Surcharge Term (s_q)
Shape Factors s_c, s_γ, s_q	$\phi_f = 0$	$1 + \left(\frac{B}{5L}\right)$	1.0	1.0
	$\phi_f > 0$	$1 + \left(\frac{B}{L}\right)\left(\frac{N_q}{N_c}\right)$	$1 - 0.4\left(\frac{B}{L}\right)$	$1 + \left(\frac{B}{L} \tan \phi_f\right)$

Table 10.6.3.1.2a-4—Depth Correction Factor d_q

Friction Angle, ϕ_f (degrees)	D_f/B	d_q
32	1	1.20
	2	1.30
	4	1.35
	8	1.40
37	1	1.20
	2	1.25
	4	1.30
	8	1.35
42	1	1.15
	2	1.20
	4	1.25
	8	1.30

The parent information from which Table 10.6.3.1.2a-4 was developed covered the indicated range of friction angle, ϕ_f . Information beyond the range indicated is not available at this time.

The depth correction factor should be used only when the soils above the footing bearing elevation are as competent as the soils beneath the footing level; otherwise, the depth correction factor should be taken as 1.0.

Linear interpolations may be made for friction angles in between those values shown in Table 10.6.3.1.2a-4.

10.6.3.1.2b—Considerations for Punching Shear

If local or punching shear failure is possible, the nominal bearing resistance shall be estimated using reduced shear strength parameters c^* and ϕ^* in Eqs. 10.6.3.1.2b-1 and 10.6.3.1.2b-2. The reduced shear parameters may be taken as:

$$c^* = 0.67c \quad (10.6.3.1.2b-1)$$

C10.6.3.1.2b

Local shear failure is characterized by a failure surface that is similar to that of a general shear failure but that does not extend to the ground surface, ending somewhere in the soil below the footing. Local shear failure is accompanied by vertical compression of soil below the footing and visible bulging of soil adjacent to the footing but not by sudden rotation or tilting of the

$$\phi^* = \tan^{-1}(0.67 \tan \phi_f) \quad (10.6.3.1.2b-2)$$

where:

c^* = reduced effective stress soil cohesion for punching shear (ksf)

ϕ^* = reduced effective stress soil friction angle for punching shear (degrees)

footing. Local shear failure is a transitional condition between general and punching shear failure. Punching shear failure is characterized by vertical shear around the perimeter of the footing and is accompanied by a vertical movement of the footing and compression of the soil immediately below the footing but does not affect the soil outside the loaded area. Punching shear failure occurs in loose or compressible soils, in weak soils under slow (drained) loading, and in dense sands for deep footings subjected to high loads.

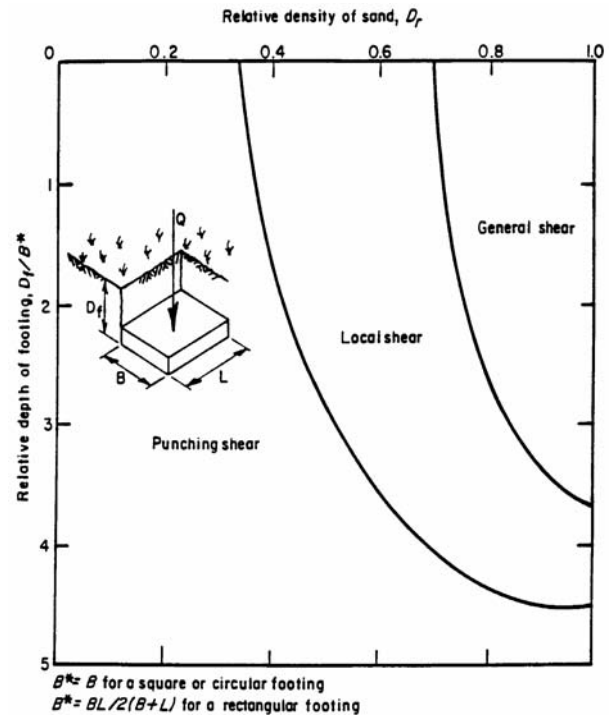

Figure C10.6.3.1.2b-1—Modes of Bearing Capacity Failure for Footings in Sand

10.6.3.1.2c—Considerations for Footings on Slopes

C10.6.3.1.2c

For footings bearing on or near slopes:

$$N_q = 0.0 \quad (10.6.3.1.2c-1)$$

In Eq. 10.6.3.1.2a-1, N_c and N_γ shall be replaced with N_{cq} and $N_{\gamma q}$, respectively, from Figures 10.6.3.1.2c-1 and 10.6.3.1.2c-2 for footings bearing on or near slopes. In Figure 10.6.3.1.2c-1, the slope stability factor, N_s , shall be taken as:

- For $B < H_s$:

$$N_s = 0 \quad (10.6.3.1.2c-2)$$

- For $B \geq H_s$:

A rational numerical approach for determining a modified bearing capacity factor, N_{cq} , for footings on or near a slope is given in Bowles (1988).

$$N_s = \frac{\gamma H_s}{c} \quad (10.6.3.1.2c-3)$$

where:

B = footing width (ft)

H_s = height of sloping ground mass (ft)

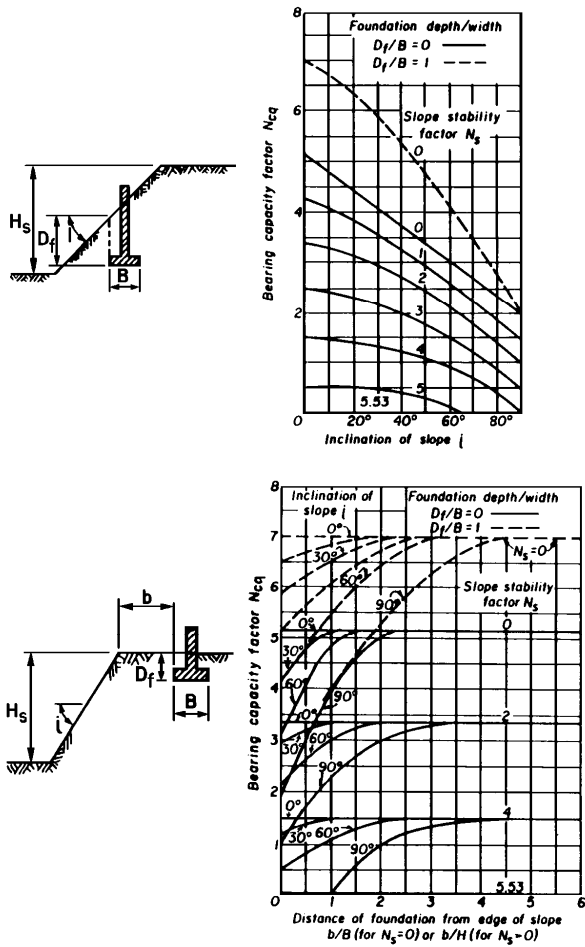

Figure 10.6.3.1.2c-1—Modified Bearing Capacity Factors for Footing in Cohesive Soils and on or adjacent to Sloping Ground after Meyerhof (1957)

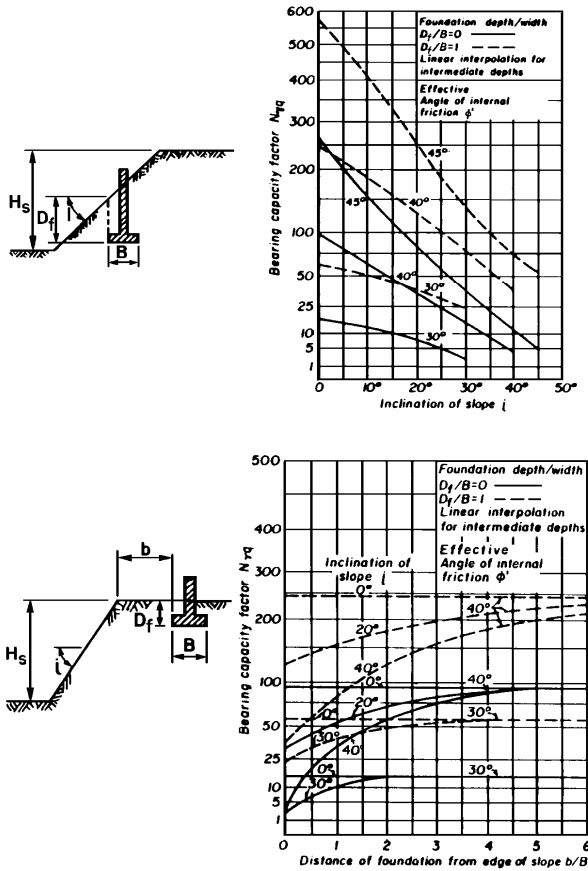

Figure 10.6.3.1.2c-2—Modified Bearing Capacity Factors for Footing in Cohesionless Soils and on or adjacent to Sloping Ground after Meyerhof (1957)

10.6.3.1.2d—Considerations for Two-Layer Soil Systems—Critical Depth

Where the soil profile contains a second layer of soil with different properties affecting shear strength within a distance below the footing less than H_{crit} , the bearing resistance of the layered soil profile shall be determined using the provisions for two-layered soil systems herein. The distance H_{crit} , in feet, may be taken as:

$$H_{crit} = \frac{(3B) \ln\left(\frac{q_1}{q_2}\right)}{2\left(1 + \frac{B}{L}\right)} \quad (10.6.3.1.2d-1)$$

where:

q_1 = nominal bearing resistance of footing supported in the upper layer of a two-layer system, assuming the upper layer is infinitely thick (ksf)

q_2 = nominal bearing resistance of a fictitious footing of the same size and shape as the actual footing but supported on surface of the second (lower) layer of a two-layer system (ksf)

B = footing width (ft)

L = footing length (ft)

10.6.3.1.2e—Two-Layered Soil System in Undrained Loading

Where a footing is supported on a two-layered soil system subjected to undrained loading, the nominal bearing resistance may be determined using Eq. 10.6.3.1.2a-1 with the following modifications:

c_1 = undrained shear strength of the top layer of soil as depicted in Figure 10.6.3.1.2e-1 (ksf)

N_{cm} = N_m , a bearing capacity factor as specified below (dim)

N_{qm} = 1.0 (dim)

Where the bearing stratum overlies a stiffer cohesive soil, N_m , may be taken as specified in Figure 10.6.3.1.2e-2.

Where the bearing stratum overlies a softer cohesive soil, N_m may be taken as:

$$N_m = \left(\frac{1}{\beta_m} + \kappa s_c N_c \right) \leq s_c N_c \quad (10.6.3.1.2e-1)$$

in which:

$$\beta_m = \frac{BL}{2(B+L)H_{s2}} \quad (10.6.3.1.2e-2)$$

$$\kappa = \frac{c_2}{c_1} \quad (10.6.3.1.2e-3)$$

where:

β_m = the punching index (dim)

c_1 = undrained shear strength of upper soil layer (ksf)

c_2 = undrained shear strength of lower soil layer (ksf)

H_{s2} = distance from bottom of footing to top of the second soil layer (ft)

C10.6.3.1.2e

Vesic' (1970) developed a rigorous solution for the modified bearing capacity factor, N_m , for the weak undrained layer over strong undrained layer situation. This solution is given by the following equation:

$$N_m = \frac{\kappa N_c^* (N_c^* + \beta_m - 1) A}{B C - (\kappa N_c^* + \beta_m - 1)(N_c^* + 1)} \quad (C10.6.3.1.2e-1)$$

in which:

$$A = [(\kappa + 1)N_c^{*2} + (1 + \kappa\beta_m)N_c^* + \beta_m - 1] \quad (C10.6.3.1.2e-2)$$

$$B = [\kappa(\kappa + 1)N_c^* + \kappa + \beta_m - 1] \quad (C10.6.3.1.2e-3)$$

$$C = [(N_c^* + \beta_m)N_c^* + \beta_m - 1] \quad (C10.6.3.1.2e-4)$$

- For circular or square footings:

$$\beta_m = \frac{B}{4H} \quad (C10.6.3.1.2e-5)$$

$$N_c^* = 6.17$$

- For strip footings:

$$\beta_m = \frac{B}{2H} \quad (C10.6.3.1.2e-6)$$

$$N_c^* = 5.14$$

s_c = shape correction factor determined from Table 10.6.3.1.2a-3

N_c = bearing capacity factor determined herein (dim)

N_{qm} = bearing capacity factor determined herein (dim)

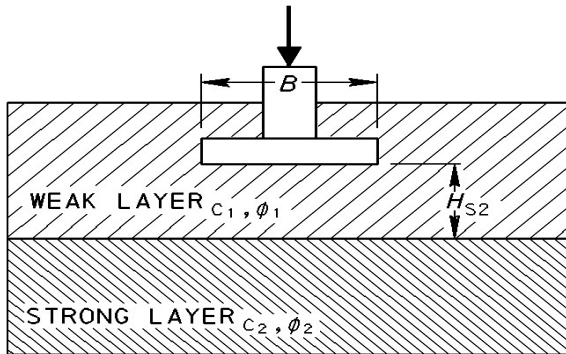

(a)

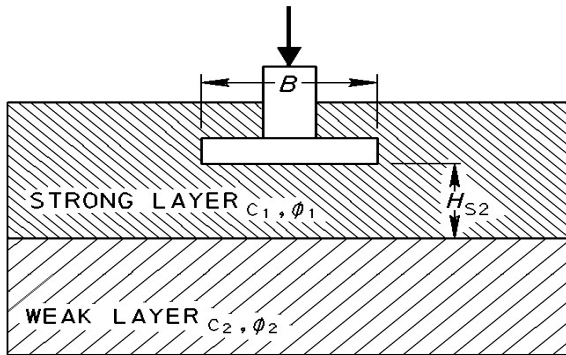

(b)

Figure 10.6.3.1.2e-1—Two-Layer Soil Profiles

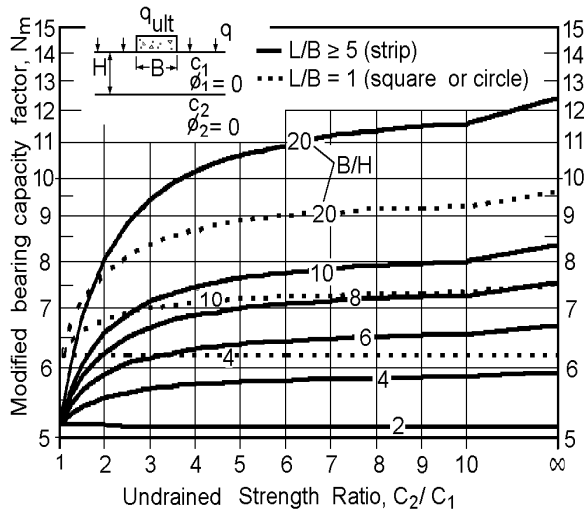

Figure 10.6.3.1.2e-2—Modified Bearing Factor for Two-Layer Cohesive Soil with Weaker Soil Overlying Stronger Soil (EPRI, 1983)

10.6.3.1.2f—Two-Layered Soil System in
Drained Loading

Where a footing supported on a two-layered soil system is subjected to a drained loading, the nominal bearing resistance, in ksf, may be taken as:

$$q_n = \left[q_2 + \left(\frac{1}{K} \right) c'_1 \cot \phi'_1 \right] e^{2 \left[1 + \left(\frac{B}{L} \right) \right] K \tan \phi'_1 \left(\frac{H}{B} \right)} - \left(\frac{1}{K} \right) c'_1 \cot \phi'_1 \quad (10.6.3.1.2f-1)$$

in which:

$$K = \frac{1 - \sin^2 \phi'_1}{1 + \sin^2 \phi'_1} \quad (10.6.3.1.2f-2)$$

where:

- c'_1 = drained shear strength of the top layer of soil as depicted in Figure 10.6.3.1.2e-1 (ksf)
- q_2 = nominal bearing resistance of a fictitious footing of the same size and shape as the actual footing but supported on surface of the second (lower) layer of a two-layer system (ksf)
- ϕ'_1 = effective stress angle of internal friction of the top layer of soil (degrees)

10.6.3.1.3—Semiempirical Procedures

The nominal bearing resistance of foundation soils may be estimated from the results of in-situ tests or by observed resistance of similar soils. The use of a particular in-situ test and the interpretation of test results should take local experience into consideration. The following in-situ tests may be used:

- Standard Penetration Test
- Cone Penetration Test

The nominal bearing resistance in sand, in ksf, based on SPT results may be taken as:

$$q_n = \frac{\bar{N}1_{60} B}{5} \left(C_{wq} \frac{D_f}{B} + C_{w\gamma} \right) \quad (10.6.3.1.3-1)$$

where:

- $\bar{N}1_{60}$ = average *SPT* blow count corrected for both overburden and hammer efficiency effects (blows/ft) as specified in Article 10.4.6.2.4. Average the blow count over a depth range from the bottom of the footing to $1.5B$ below the bottom of the footing.
- B = footing width (ft)

C10.6.3.1.2f

If the upper layer is a cohesionless soil and ϕ' equals 25–50 degrees, Eq. 10.6.3.1.2f-1 reduces to:

$$q_n = q_2 e^{0.67 \left[1 + \left(\frac{B}{L} \right) \right] \frac{H}{B}} \quad (C10.6.3.1.2f-1)$$

C10.6.3.1.3

In application of these empirical methods, the use of average *SPT* blow counts and *CPT* tip resistances is specified. The resistance factors recommended for bearing resistance included in Table 10.5.5.2.2-1 assume the use of average values for these parameters. The use of lower bound values may result in an overly conservative design. However, depending on the availability of soil property data and the variability of the geologic strata under consideration, it may not be possible to reliably estimate the average value of the properties needed for design. In such cases, the Engineer may have no choice but to use a more conservative selection of design input parameters to mitigate the additional risks created by potential variability or the paucity of relevant data.

The original derivation of Eqs. 10.6.3.1.3-1 and 10.6.3.1.3-2 did not include inclination factors (Meyerhof, 1956).

C_{wq}, C_{wy} = correction factors to account for the location of the groundwater table as specified in Table 10.6.3.1.2a-2 (dim)

D_f = footing embedment depth taken to the bottom of the footing (ft)

The nominal bearing resistance, in ksf, for footings on cohesionless soils based on *CPT* results may be taken as:

$$q_n = \frac{\bar{q}_c B}{40} \left(C_{wq} \frac{D_f}{B} + C_{wy} \right) \quad (10.6.3.1.3-2)$$

where:

\bar{q}_c = average cone tip resistance within a depth range B below the bottom of the footing (ksf)

B = footing width (ft)

C_{wq}, C_{wy} = correction factors to account for the location of the groundwater table as specified in Table 10.6.3.1.2a-2 (dim)

D_f = footing embedment depth taken to the bottom of the footing (ft)

10.6.3.1.4—Plate Load Tests

The nominal bearing resistance may be determined by plate load tests, provided that adequate subsurface explorations have been made to determine the soil profile below the foundation. Where plate load tests are conducted, they should be conducted in accordance with AASHTO T 235 and ASTM D1194.

The nominal bearing resistance determined from a plate load test may be extrapolated to adjacent footings where the subsurface profile is confirmed by subsurface exploration to be similar.

10.6.3.2—Bearing Resistance of Rock

10.6.3.2.1—General

The methods used for design of footings on rock shall consider the presence, orientation, and condition of discontinuities, weathering profiles, and other similar profiles as they apply at a particular site.

For footings on competent rock, reliance on simple and direct analyses based on uniaxial compressive rock strengths and *RQD* may be applicable. For footings on less competent rock, more detailed investigations and

C10.6.3.1.4

Plate load tests have a limited depth of influence and furthermore may not disclose the potential for long-term consolidation of foundation soils.

Scale effects should be addressed when extrapolating the results to performance of full scale footings. Extrapolation of the plate load test data to a full scale footing should be based on the design procedures provided herein for settlement (service limit state) and bearing resistance (strength and extreme event limit state), with consideration to the effect of the stratification, i.e., layer thicknesses, depths, and properties. Plate load test results should be applied only within a sub-area of the project site for which the subsurface conditions, i.e., stratification, geologic history, and properties, are relatively uniform.

C10.6.3.2.1

The design of spread footings bearing on rock is frequently controlled by either overall stability, i.e., the orientation and conditions of discontinuities, or load eccentricity considerations. The designer should verify adequate overall stability at the service limit state and size the footing based on eccentricity requirements at the strength limit state before checking nominal bearing resistance at both the service and strength limit states.

analyses shall be performed to account for the effects of weathering and the presence and condition of discontinuities.

The designer shall judge the competency of a rock mass by taking into consideration both the nature of the intact rock and the orientation and condition of discontinuities of the overall rock mass. Where engineering judgment does not verify the presence of competent rock, the competency of the rock mass should be verified using the procedures for *RMR* rating in Article 10.4.6.4.

10.6.3.2.2—Semiempirical Procedures

The nominal bearing resistance of rock should be determined using empirical correlation with the Geomechanics Rock Mass Rating system. Local experience shall be considered in the use of these semi-empirical procedures.

The factored bearing stress of the foundation shall not be taken to be greater than the factored compressive resistance of the footing concrete.

10.6.3.2.3—Analytic Method

The nominal bearing resistance of foundations on rock shall be determined using established rock mechanics principles based on the rock mass strength parameters. The influence of discontinuities on the failure mode shall also be considered.

10.6.3.2.4—Load Test

Where appropriate, load tests may be performed to determine the nominal bearing resistance of foundations on rock.

10.6.3.3—Eccentric Load Limitations

The eccentricity of loading at the strength limit state, evaluated based on factored loads shall not exceed:

- One-third of the corresponding footing dimension, B or L , for footings on soils, or 0.45 of the corresponding footing dimensions B or L , for footings on rock.

C10.6.3.2.2

The bearing resistance of jointed or broken rock may be estimated using the semi-empirical procedure developed by Carter and Kulhawy (1988). This procedure is based on the unconfined compressive strength of the intact rock core sample. Depending on rock mass quality measured in terms of *RMR* system, the nominal bearing resistance of a rock mass varies from a small fraction to six times the unconfined compressive strength of intact rock core samples.

C10.6.3.2.3

Depending upon the relative spacing of joints and rock layering, bearing capacity failures for foundations on rock may take several forms. Except for the case of a rock mass with closed joints, the failure modes are different from those in soil. Procedures for estimating bearing resistance for each of the failure modes can be found in Kulhawy and Goodman (1987), Goodman (1989), and Sowers (1979).

C10.6.3.3

A comprehensive parametric study was conducted for cantilevered retaining walls of various heights and soil conditions. The base widths obtained using the LRFD load factors and eccentricity of $B/3$ were comparable to those of ASD with an eccentricity of $B/6$. For foundations on rock, to obtain equivalence with ASD specifications, a maximum eccentricity of $B/2$ would be needed for LRFD. However, a slightly smaller maximum eccentricity has been specified to account for the potential unknown future loading that could push the resultant outside the footing dimensions.

10.6.3.4—Failure by Sliding

Failure by sliding shall be investigated for footings that support horizontal or inclined load and/or are founded on slopes.

For foundations on clay soils, the possible presence of a shrinkage gap between the soil and the foundation shall be considered. If passive resistance is included as part of the shear resistance required for resisting sliding, consideration shall also be given to possible future removal of the soil in front of the foundation.

The factored resistance against failure by sliding, in kips, shall be taken as:

$$R_R = \phi R_n = \phi_\tau R_\tau + \phi_{ep} R_{ep} \quad (10.6.3.4-1)$$

where:

R_n = nominal sliding resistance against failure by sliding (kips)

ϕ_τ = resistance factor for shear resistance between soil and foundation specified in Table 10.5.5.2.2-1

R_τ = nominal sliding resistance between soil and foundation (kips)

ϕ_{ep} = resistance factor for passive resistance specified in Table 10.5.5.2.2-1

R_{ep} = nominal passive resistance of soil available throughout the design life of the structure (kips)

If the soil beneath the footing is cohesionless, the nominal sliding resistance between soil and foundation shall be taken as:

$$R_\tau = V \tan \delta \quad (10.6.3.4-2)$$

for which:

$\tan \delta$ = $\tan \phi_f$ for concrete cast against soil
 = $0.8 \tan \phi_f$ for precast concrete footing

where:

ϕ_f = internal friction angle of drained soil (degrees)

V = total vertical force (kips)

For footings that rest on clay, the sliding resistance may be taken as the lesser of:

- The cohesion of the clay, or

C10.6.3.4

Sliding failure occurs if the force effects due to the horizontal component of loads exceed the more critical of either the factored shear resistance of the soils or the factored shear resistance at the interface between the soil and the foundation.

For footings on cohesionless soils, sliding resistance depends on the roughness of the interface between the foundation and the soil.

The magnitudes of active earth load and passive resistance depend on the type of backfill material, the wall movement, and the compactive effort. Their magnitude can be estimated using procedures described in Sections 3 and 11.

In most cases, the movement of the structure and its foundation will be small. Consequently, if passive resistance is included in the resistance, its magnitude is commonly taken as 50 percent of the maximum passive resistance. This is the basis for the resistance factor, ϕ_{ep} , in Table 10.5.5.2.2-1.

The units for R_R , R_n , and R_{ep} are shown in kips. For elements designed on a unit length basis, these quantities will have the units of kips per unit length.

Rough footing bases usually occur where footings are cast in-situ. Precast concrete footings may have smooth bases.

- Where footings are supported on at least 6.0 in. of compacted granular material, one-half the normal stress on the interface between the footing and soil, as shown in Figure 10.6.3.4-1 for retaining walls.

The following notation shall be taken to apply to Figure 10.6.3.4-1:

q_s = unit shear resistance, equal to S_u or $0.5 \sigma'_v$, whichever is less

R_τ = nominal sliding resistance between soil and foundation (kips) expressed as the shaded area under the q_s diagram

S_u = undrained shear strength (ksf)

σ'_v = vertical effective stress (ksf)

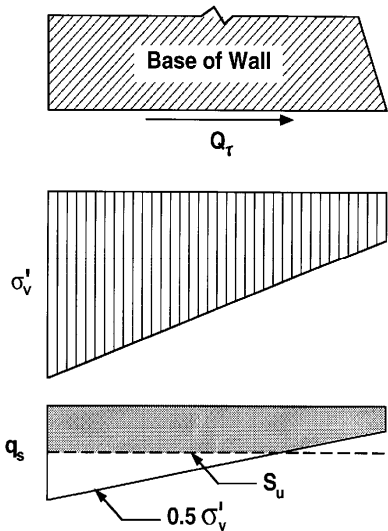

Figure 10.6.3.4-1—Procedure for Estimating Nominal Sliding Resistance for Walls on Clay

10.6.4—Extreme Event Limit State Design

10.6.4.1—General

Extreme limit state design checks for spread footings shall include, but not necessarily be limited to:

- Bearing resistance,
- Eccentric load limitations (overturning),
- Sliding, and
- Overall stability.

Resistance factors shall be as specified in Article 10.5.5.3.

10.6.4.2—Eccentric Load Limitations

For footings, whether on soil or on rock, the eccentricity of loading for extreme limit states shall not exceed the limits provided in Article 11.6.5.

If live loads act to reduce the eccentricity for the Extreme I limit state, γ_{EQ} shall be taken as 0.0.

10.6.5—Structural Design

The structural design of footings shall comply with the requirements given in Section 5.

For structural design of an eccentrically loaded foundation, a triangular or trapezoidal contact stress distribution based on factored loads shall be used for footings bearing on all soil and rock conditions.

For purposes of structural design, it is usually assumed that the bearing stress varies linearly across the bottom of the footing. This assumption results in the slightly conservative triangular or trapezoidal contact stress distribution.

10.7—DRIVEN PILES

10.7.1—General

10.7.1.1—Application

Driven piling should be considered in the following situations:

- When spread footings cannot be founded on rock, or on competent soils at a reasonable cost,
- At locations where soil conditions would normally permit the use of spread footings but the potential exists for scour, liquefaction or lateral spreading, in which case driven piles bearing on suitable materials below susceptible soils should be considered for use as a protection against these problems,
- Where right-of-way or other space limitations would not allow the use spread footings,
- Where existing soil, contaminated by hazardous materials, must be removed for the construction of spread footings, or
- Where an unacceptable amount of settlement of spread footings may occur.

10.7.1.2—Minimum Pile Spacing, Clearance, and Embedment into Cap

Center-to-center pile spacing should not be less than 30.0 in. or 2.5 pile diameters. The distance from the side of any pile to the nearest edge of the pile cap shall not be less than 9.0 in.

The tops of piles shall project at least 12.0 in. into the pile cap after all damaged material has been removed. If the pile is attached to the cap by embedded bars or strands, the pile shall extend no less than 6.0 in. into the cap.

Where a reinforced concrete beam is cast-in-place and used as a bent cap supported by piles, the concrete cover on the sides of the piles shall not be less than 6.0 in., plus an allowance for permissible pile misalignment. Where pile reinforcement is anchored in the cap satisfying the requirements of Article 5.13.4.1, the projection may be less than 6.0 in.

10.7.1.3—Piles through Embankment Fill

Piles to be driven through embankments should penetrate a minimum of 10 ft through original ground unless refusal on bedrock or competent bearing strata occurs at a lesser penetration.

Fill used for embankment construction should be a select material, which does not obstruct pile penetration to the required depth.

10.7.1.4—Batter Piles

When the lateral resistance of the soil surrounding the piles is inadequate to counteract the horizontal forces transmitted to the foundation, or when increased rigidity of the entire structure is required, batter piles should be considered for use. Where negative side resistance (downdrag) loads are expected, batter piles should be avoided. If batter piles are used in areas of significant seismic loading, the design of the pile foundation shall recognize the increased foundation stiffness that results.

10.7.1.5—Pile Design Requirements

Pile design shall address the following issues as appropriate:

- Nominal bearing resistance to be specified in the contract, type of pile, and size of pile group required to provide adequate support, with consideration of how nominal bearing pile resistance will be determined in the field.
- Group interaction.
- Pile quantity estimation and estimated pile penetration required to meet nominal axial resistance and other design requirements.
- Minimum pile penetration necessary to satisfy the requirements caused by uplift, scour, downdrag, settlement, liquefaction, lateral loads, and seismic conditions.

C10.7.1.3

If refusal occurs at a depth of less than 10 ft, other foundation types, e.g., footings or shafts, may be more effective.

To minimize the potential for obstruction of the piles, the maximum size of any rock particles in the fill should not exceed 6.0 in. Pre-drilling or spudding pile locations should be considered in situations where obstructions in the embankment fill cannot be avoided, particularly for displacement piles. Note that predrilling or spudding may reduce the pile side resistance and lateral resistance, depending on how the predrilling or spudding is conducted. The diameter of the predrilled or spudded hole, and the potential for caving of the hole before the pile is installed will need to be considered to assess the effect this will have on side and lateral resistance.

If compressible soils are located beneath the embankment, piles should be driven after embankment settlement is complete, if possible, to minimize or eliminate downdrag forces.

C10.7.1.4

In some cases, it may be desirable to use batter piles. From a general viewpoint, batter piles provide a much stiffer resistance to lateral loads than would be possible with vertical piles. They can be very effective in resisting static lateral loads.

Due to increased foundation stiffness, batter piles may not be desirable in resisting lateral dynamic loads if the structure is located in an area where seismic loads are potentially high.

C10.7.1.5

The driven pile design process is discussed in detail in Hannigan et al. (2006).

- Foundation deflection to meet the established movement and associated structure performance criteria.
- Pile foundation nominal structural resistance.
- Pile drivability to confirm that acceptable driving stresses and blow counts can be achieved at the nominal bearing resistance, and at the estimated resistance to reach the minimum tip elevation, if a minimum tip elevation is required, with an available driving system.
- Long-term durability of the pile in service, i.e. corrosion and deterioration.

10.7.1.6—Determination of Pile Loads

10.7.1.6.1—General

The loads and load factors to be used in pile foundation design shall be as specified in Section 3. Computational assumptions that shall be used in determining individual pile loads are described in Section 4.

10.7.1.6.2—Downdrag

The provisions of Article 3.11.8 shall apply for determination of load due to negative side resistance.

Where piles are driven to end bearing on a dense stratum or rock and the design of the pile is structurally controlled, downdrag shall be considered at the strength and extreme limit states.

For friction piles that can experience settlement at the pile tip, downdrag shall be considered at the service, strength and extreme limit states. Estimate pile and pile group settlement according to Article 10.7.2.

The nominal pile resistance available to support structure loads plus downdrag shall be estimated by considering only the positive side and tip resistance below the lowest layer contributing to downdrag computed as specified in Article 3.11.8.

10.7.1.6.3—Uplift Due to Expansive Soils

Piles penetrating expansive soil shall extend to a depth into moisture-stable soils sufficient to provide adequate anchorage to resist uplift. Sufficient clearance should be provided between the ground surface and underside of caps or beams connecting piles to preclude the application of uplift loads at the pile/cap connection due to swelling ground conditions.

C10.7.1.6.1

The specification and determination of top of cap loads is discussed in Section 3. The Engineer should select different levels of analysis, detail and accuracy as appropriate for the structure under consideration. Details are discussed in Section 4.

C10.7.1.6.2

Downdrag occurs when settlement of soils along the side of the piles results in downward movement of the soil relative to the pile. See commentary to Article C3.11.8.

In the case of friction piles with limited tip resistance, the downdrag load can exceed the geotechnical resistance of the pile, causing the pile to move downward enough to allow service limit state criteria for the structure to be exceeded. Where pile settlement is not limited by nominal bearing resistance below the downdrag zone, service limit state tolerances will govern the geotechnical design.

This design situation is not desirable and the preferred practice is to mitigate the downdrag induced foundation settlement through a properly designed surcharge and/or preloading program, or by extending the piles deeper for higher resistance.

Instrumented static load tests, dynamic tests with signal matching, or static analysis procedures in Article 10.7.3.8.6 may be used to estimate the available nominal resistance to withstand the downdrag plus structure loads.

C10.7.1.6.3

Evaluation of potential uplift loads on piles extending through expansive soils requires evaluation of the swell potential of the soil and the extent of the soil strata that may affect the pile. One reasonably reliable method for identifying swell potential is presented in Table 10.4.6.3-1. Alternatively, ASTM D4829 may be used to evaluate swell potential. The thickness of the potentially expansive stratum must be identified by:

- Examination of soil samples from borings for the presence of jointing, slickensiding, or a blocky structure and for changes in color, and
- Laboratory testing for determination of soil moisture content profiles.

10.7.1.6.4—Nearby Structures

Where pile foundations are placed adjacent to existing structures, the influence of the existing structure on the behavior of the foundation, and the effect of the new foundation on the existing structures, including vibration effects due to pile installation, shall be investigated.

C10.7.1.6.4

Vibration due to pile driving can cause settlement of existing foundations as well as structural damage to the adjacent facility, especially in loose cohesionless soils. The combination of taking measures to mitigate the vibration levels through use of nondisplacement piles, predrilling, proper hammer choice, etc., and a good vibration monitoring program should be considered.

10.7.2—Service Limit State Design

10.7.2.1—General

Service limit state design of driven pile foundations includes the evaluation of settlement due to static loads, and downdrag loads if present, overall stability, lateral squeeze, and lateral deformation. Overall stability of a pile supported foundation shall be evaluated where:

- The foundation is placed through an embankment,
- The pile foundation is located on, near or within a slope,
- The possibility of loss of foundation support through erosion or scour exists, or
- Bearing strata are significantly inclined.

Unbalanced lateral forces caused by lack of overall stability or lateral squeeze should be mitigated through stabilization measures, if possible.

10.7.2.2—Tolerable Movements

The provisions of Article 10.5.2.1 shall apply.

10.7.2.3—Settlement

10.7.2.3.1—Equivalent Footing Analogy

For purposes of calculating the settlements of pile groups, loads should be assumed to act on an equivalent footing based on the depth of embedment of the piles into the layer that provides support as shown in Figures 10.7.2.3.1-1 and 10.7.2.3.1-2.

Pile group settlement shall be evaluated for pile foundations in cohesive soils, soils that include cohesive layers, and piles in loose granular soils. The load used in calculating settlement shall be the permanently applied load on the foundation.

In applying the equivalent footing analogy for pile foundation, the reduction to equivalent dimensions B' and L' as used for spread footing design does not apply.

C10.7.2.1

Lateral analysis of pile foundations is conducted to establish the load distribution between the superstructure and foundations for all limit states, and to estimate the deformation in the foundation that will occur due to those loads. This Article only addresses the evaluation of the lateral deformation of the foundation resulting from the distributed loads.

In general, it is not desirable to subject the pile foundation to unbalanced lateral loading caused by lack of overall stability or caused by lateral squeeze.

C10.7.2.2

See Article C10.5.2.1.

C10.7.2.3.1

Pile design should ensure that strength limit state considerations are satisfied before checking service limit state considerations.

For piles embedded adequately into dense granular soils such that the equivalent footing is located on or within the dense granular soil, and furthermore are not subjected to downdrag loads, a detailed assessment of the pile group settlement may be waived.

Methods for calculating settlement are discussed in Hannigan et al., (2006).

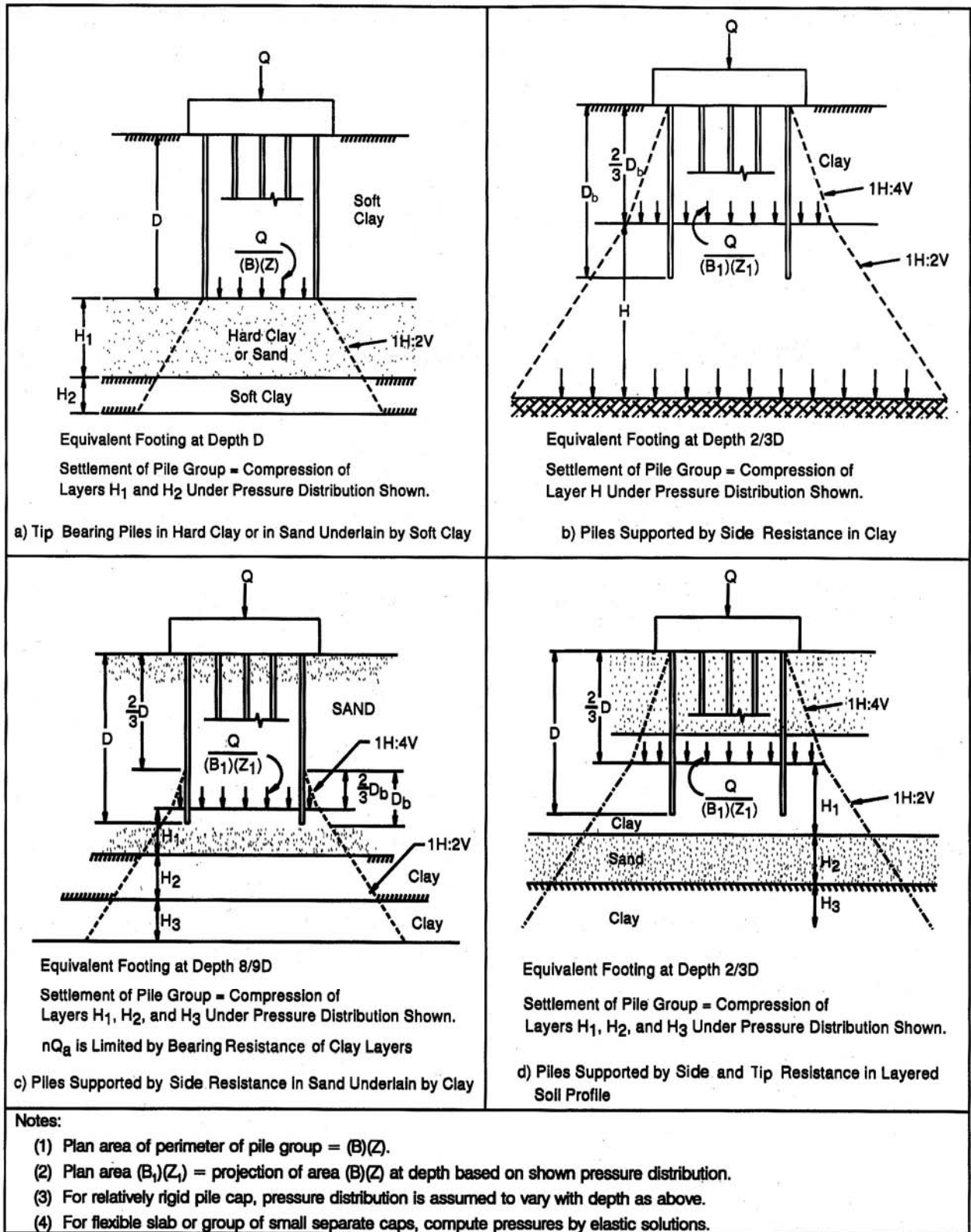

Figure 10.7.2.3.1-1—Stress Distribution below Equivalent Footing for Pile Group after Hannigan et al. (2006)

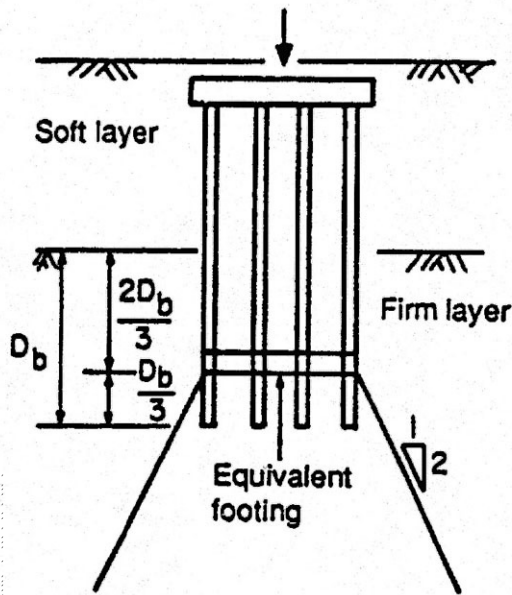

Figure 10.7.2.3.1-2—Location of Equivalent Footing (after Duncan and Buchignani, 1976)

10.7.2.3.2—Pile Groups in Cohesive Soil

C10.7.2.3.2

Shallow foundation settlement estimation procedures shall be used to estimate the settlement of a pile group, using the equivalent footing location specified in Figure 10.7.2.3-1.1 or Figure 10.7.2.3.1-2.

The settlement of pile groups in cohesionless soils may be taken as:

$$\text{Using } SPT: \rho = \frac{qI\sqrt{B}}{N_{160}} \quad (10.7.2.3.2-1)$$

$$\text{Using } CPT: \rho = \frac{qBI}{2q_c} \quad (10.7.2.3.2-2)$$

in which:

$$I = 1 - 0.125 \frac{D'}{B} \geq 0.5 \quad (10.7.2.3.2-3)$$

where:

- ρ = settlement of pile group (in.)
- q = net foundation pressure applied at $2D_b/3$, as shown in Figure 10.7.2.3.1-1; this pressure is equal to the applied load at the top of the group divided by the area of the equivalent footing and does not include the weight of the piles or the soil between the piles (ksf)
- B = width or smallest dimension of pile group (ft)

The provisions are based upon the use of empirical correlations proposed by Meyerhof (1976). These are empirical correlations and the units of measure must match those specified for correct computations. This method may tend to over-predict settlements.

- I = influence factor of the effective group embedment (dim)
- D' = effective depth taken as $2D_b/3$ (ft)
- D_b = depth of embedment of piles in layer that provides support, as specified in Figure 10.7.2.3.1-1 (ft)
- N_{160} = *SPT* blow count corrected for both overburden and hammer efficiency effects (blows/ft) as specified in Article 10.4.6.2.4.
- q_c = static cone tip resistance (ksf)

Alternatively, other methods for computing settlement in cohesionless soil, such as the Hough method as specified in Article 10.6.2.4.2 may also be used in connection with the equivalent footing approach.

The corrected *SPT* blow count or the static cone tip resistance should be averaged over a depth equal to the pile group width B below the equivalent footing. The *SPT* and *CPT* methods (Eqs. 10.7.2.3.2-1 and 10.7.2.3.2-2) shall only be considered applicable to the distributions shown in Figure 10.7.2.3.1-1b and Figure 10.7.2.3.1-2.

10.7.2.4—Horizontal Pile Foundation Movement

Horizontal movement induced by lateral loads shall be evaluated. The provisions of Article 10.5.2.1 shall apply regarding horizontal movement criteria.

The horizontal movement of pile foundations shall be estimated using procedures that consider soil-structure interaction. Tolerable horizontal movements of piles shall be established on the basis of confirming compatible movements of structural components, e.g., pile to column connections, for the loading condition under consideration.

The effects of the lateral resistance provided by an embedded cap may be considered in the evaluation of horizontal movement.

The orientation of nonsymmetrical pile cross-sections shall be considered when computing the pile lateral stiffness.

Lateral resistance of single piles may be determined by static load test. If a static lateral load test is to be performed, it shall follow the procedures specified in ASTM D3966.

The effects of group interaction shall be taken into account when evaluating pile group horizontal movement. When the P - y method of analysis is used, the values of P shall be multiplied by P -multiplier values, P_m , to account for group effects. The values of P_m provided in Table 10.7.2.4-1 should be used.

C10.7.2.4

Pile foundations are subjected to lateral loads due to wind, traffic loads, bridge curvature, vessel or traffic impact and earthquake. Batter piles are sometimes used but they are somewhat more expensive than vertical piles, and vertical piles are more effective against dynamic loads.

Methods of analysis that use manual computation were developed by Broms (1964a and 1964b). They are discussed in detail by Hannigan et al. (2006). Reese developed analysis methods that model the horizontal soil resistance using P - y curves. This analysis has been well developed and software is available for analyzing single piles and pile groups (Reese, 1986; Williams et al., 2003; and Hannigan et al., 2006).

Deep foundation horizontal movement at the foundation design stage may be analyzed using computer applications that consider soil-structure interaction. Application formulations are available that consider the total structure including pile cap, pier and superstructure (Williams et al., 2003).

If a lateral static load test is used to assess the site specific lateral resistance of a pile, information on the methods of analysis and interpretation of lateral load tests presented in the *Handbook on Design of Piles and Drilled Shafts Under Lateral Load*, Reese (1984) and *Static Testing of Deep Foundations*, Kyfor et al. (1992) should be used.

Table 10.7.2.4-1—Pile P-Multipliers, P_m , for Multiple Row Shading (averaged from Hannigan et al., 2006)

Pile CTC spacing (in the direction of loading)	P -Multipliers, P_m		
	Row 1	Row 2	Row 3 and higher
$3B$	0.8	0.4	0.3
$5B$	1.0	0.85	0.7

Loading direction and spacing shall be taken as defined in Figure 10.7.2.4-1. If the loading direction for a single row of piles is perpendicular to the row (bottom detail in the Figure), a group reduction factor of less than 1.0 should only be used if the pile spacing is $5B$ or less, i.e., a P_m of 0.8 for a spacing of $3B$, as shown in Figure 10.7.2.4-1.

Since many piles are installed in groups, the horizontal resistance of the group has been studied and it has been found that multiple rows of piles will have less resistance than the sum of the single pile resistance. The front piles “shade” rows that are further back.

The P -multipliers, P_m , in Table 10.7.2.4-1 are a function of the center-to-center (CTC) spacing of piles in the group in the direction of loading expressed in multiples of the pile diameter, B . The values of P_m in Table 10.7.2.4-1 were developed for vertical piles only.

Lateral load tests have been performed on pile groups, and multipliers have been determined that can be used in the analysis for the various rows. Those multipliers have been found to depend on the pile spacing and the row number in the direction of loading. To establish values of P_m for other pile spacing values, interpolation between values should be conducted.

The multipliers are a topic of current research and may change in the future. Values from recent research have been tabulated by Hannigan et al. (2006).

Note that these P -y methods generally apply to foundation elements that have some ability to bend and deflect. For large diameter, relatively short foundation elements, e.g., drilled shafts or relatively short stiff piles, the foundation element rotates rather than bends, in which case strain wedge theory (Norris, 1986; Ashour et al., 1998) may be more applicable. When strain wedge theory is used to assess the lateral load response of groups of short, large diameter piles or shaft groups, group effects should be addressed through evaluation of the overlap between shear zones formed due to the passive wedge that develops in front of each shaft in the group as lateral deflection increases. Note that P_m in Table 10.7.2.4-1 is not applicable if strain wedge theory is used.

Batter piles provide a much stiffer lateral response than vertical piles when loaded in the direction of the batter.

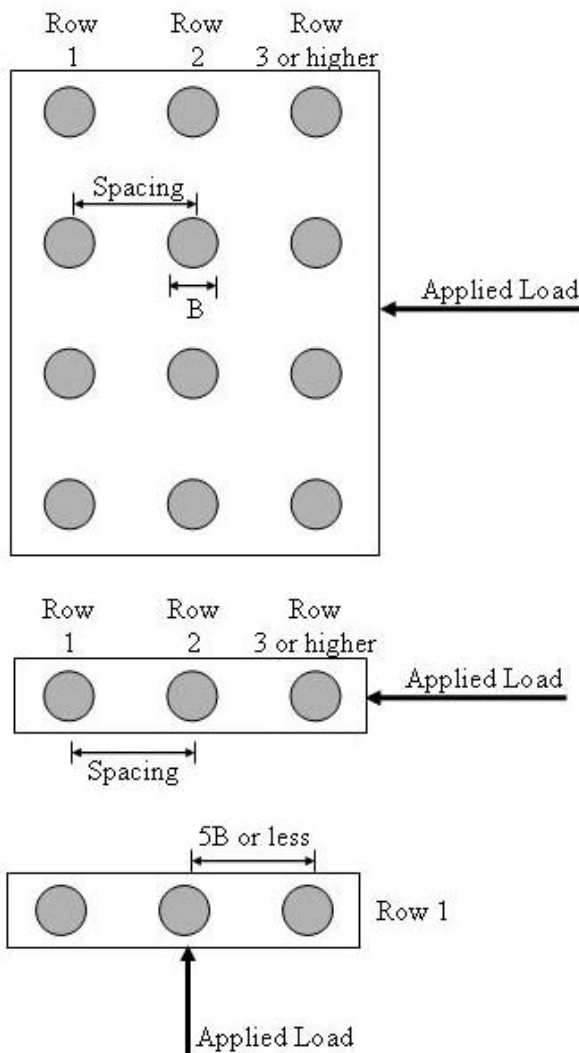

Figure 10.7.2.4-1—Definition of Loading Direction and Spacing for Group Effects

10.7.2.5—Settlement Due to Downdrag

The nominal pile resistance available to support structure loads plus downdrag shall be estimated by considering only the positive side and tip resistance below the lowest layer contributing to the downdrag. In general, the available factored geotechnical resistance should be greater than the factored loads applied to the pile, including the downdrag, at the service limit state. In the case where it is not possible to obtain adequate geotechnical resistance below the lowest layer contributing to downdrag, e.g., piles supported by side resistance, to fully resist the downdrag, the structure should be designed to tolerate the full amount of settlement resulting from the downdrag and the other applied loads.

If adequate geotechnical resistance is available to resist the downdrag plus structure loads in the service limit state, the amount of deformation needed to fully mobilize the geotechnical resistance should be estimated, and the structure designed to tolerate the anticipated movement.

10.7.2.6—Lateral Squeeze

Bridge abutments supported on pile foundations driven through soft soils that are subject to unbalanced embankment fill loading shall be evaluated for lateral squeeze.

10.7.3—Strength Limit State Design**10.7.3.1—General**

For strength limit state design, the following shall be determined:

- Loads and performance requirements;
- Pile type, dimensions, and nominal bearing resistance;
- Size and configuration of the pile group to provide adequate foundation support;
- Estimated pile length to be used in the construction contract documents to provide a basis for bidding;
- A minimum pile penetration, if required, for the particular site conditions and loading, determined based on the maximum (deepest) depth needed to meet all of the applicable requirements identified in Article 10.7.6;

C10.7.2.5

The static analysis procedures in Article 10.7.3.8.6 may be used to estimate the available pile nominal resistance to withstand the downdrag plus structure loads.

Nominal resistance may also be estimated using a dynamic method, e.g., dynamic measurements with signal matching analysis, wave equation, pile driving formula, etc., per Article 10.7.3.8, provided the side resistance within the zone contributing to downdrag is subtracted from the nominal bearing resistance determined from the dynamic method during pile installation. The side resistance within the zone contributing to downdrag may be estimated using the static analysis methods specified in Article 10.7.3.8.6, from signal matching analysis, or from instrumented pile load test results. Note that the static analysis methods may have bias that, on average, over or under predicts the side resistance. The bias of the method selected to estimate the side resistance within the downdrag zone should be taken into account as described in Article 10.7.3.3.

For the establishment of settlement tolerance limits, see Article 10.5.2.1.

C10.7.2.6

Guidance on evaluating the potential for lateral squeeze and potential mitigation methods are included in Hannigan et al., (2006).

C10.7.3.1

A minimum pile penetration should only be specified if needed to ensure that uplift, lateral stability, depth to resist downdrag, depth to satisfy scour concerns, and depth for structural lateral resistance are met for the strength limit state, in addition to similar requirements

- The maximum driving resistance expected in order to reach the minimum pile penetration required, if applicable, including any soil/pile side resistance that will not contribute to the long-term nominal bearing resistance of the pile, e.g., soil contributing to downdrag, or soil that will be removed by scour;
- The drivability of the selected pile to achieve the required nominal axial resistance or minimum penetration with acceptable driving stresses at a satisfactory blow count per unit length of penetration; and
- The nominal structural resistance of the pile and/or pile group.

10.7.3.2—Point Bearing Piles on Rock

10.7.3.2.1—General

As applied to pile compressive resistance, this Article shall be considered applicable to soft rock, hard rock, and very strong soils such as very dense glacial tills that will provide high nominal bearing resistance in compression with little penetration.

10.7.3.2.2—Piles Driven to Soft Rock

Soft rock that can be penetrated by pile driving shall be treated in the same manner as soil for the purpose of design for bearing resistance, in accordance with Article 10.7.3.8.

10.7.3.2.3—Piles Driven to Hard Rock

The nominal resistance of piles driven to point bearing on hard rock where pile penetration into the rock formation is minimal is controlled by the structural limit state. The nominal bearing resistance shall not exceed the values obtained from Article 6.9.4.1 with the resistance factors specified in Article 6.5.4.2 and Article 6.15 for severe driving conditions. A pile-driving acceptance criteria shall be developed that will prevent pile damage. Dynamic pile measurements should be used to monitor for pile damage.

for the service and extreme event limit states. See Article 10.7.6 for additional details. Assuming static load tests, dynamic methods, e.g., dynamic test with signal matching, wave equation, pile formulae, etc., are used during pile installation to establish when the nominal bearing resistance has been met, a minimum pile penetration should not be used to ensure that the required nominal pile bearing, i.e., compression, resistance is obtained.

A nominal resistance measured during driving exceeding the compressive nominal resistance required by the contract may be needed in order to reach a minimum pile penetration specified in the contract.

The drivability analysis is performed to establish whether a hammer and driving system will likely install the pile in a satisfactory manner.

C10.7.3.2.1

If pile penetration into rock is expected to be minimal, the prediction of the required pile length will usually be based on the depth to rock.

A definition of hard rock that relates to measurable rock characteristics has not been widely accepted. Local or regional experience with driving piles to rock provides the most reliable definition.

In general, it is not practical to drive piles into rock to obtain significant uplift or lateral resistance. The ability to obtain sufficient uplift resistance will depend on the softness of the rock formation. Local experience should also be considered. If significant lateral or uplift foundation resistance is required, drilled shaft foundations should be considered. If it is still desired to use piles, a pile drivability study should be performed to verify the feasibility of obtaining the desired penetration into rock.

C10.7.3.2.2

Steel piles driven into soft rock may not require tip protection.

C10.7.3.2.3

Care should be exercised in driving piles to hard rock to avoid tip damage. The tips of steel piles driven to hard rock should be protected by high strength, cast steel tip protection.

If the rock surface is reasonably flat, installation with pile tip protection should be considered. In the case of sloping rock, or when battered piles are driven to rock, greater difficulty can arise and the use of tip protection with teeth should be considered. The designer should perform a wave equation analysis to check anticipated stresses, and also consider the following to minimize the risk of pile damage during installation:

- Use a relatively small hammer. If a hammer with adjustable stroke or energy setting is used, it should be operated with a small stroke to seat the pile. The nominal axial resistance can then be proven with a few larger hammer blows.
- A large hammer should not be used if it cannot be adjusted to a low stroke. It may be impossible to detect possible toe damage if a large hammer with large stroke is used.
- For any hammer size, specify a limited number of hammer blows after the pile tip reaches the rock, and stop immediately. An example of a limiting criteria is five blows per one half inch.
- Extensive dynamic testing can be used to verify bearing resistance on a large percentage of the piles. This approach could be used to justify larger design nominal resistances.

If such measures are taken, and successful local experience is available, it may be acceptable to not conduct the dynamic pile measurements.

10.7.3.3—Pile Length Estimates for Contract Documents

Subsurface geotechnical information combined with static analysis methods (Article 10.7.3.8.6), preconstruction probe pile programs (Article 10.7.9), and/or pile load tests (Article 10.7.3.8.2) shall be used to estimate the depth of penetration required to achieve the desired nominal bearing resistance to establish contract pile quantities. If static analysis methods are used, potential bias in the method selected should be considered when estimating the penetration depth required to achieve the desired nominal bearing resistance. Local pile driving experience shall also be considered when making pile quantity estimates. If the depth of penetration required to obtain the desired nominal bearing, i.e., compressive, resistance is less than the depth required to meet the provisions of Article 10.7.6, the minimum penetration required per Article 10.7.6 should be used as the basis for estimating contract pile quantities.

C10.7.3.3

The estimated pile length necessary to provide the required nominal resistance is determined using a static analysis, local pile driving experience, knowledge of the site subsurface conditions, and/or results from a static pile load test program. The required pile length is often defined by the presence of an obvious bearing layer. Local pile driving experience with such a bearing layer should be strongly considered when developing pile quantity estimates.

In variable soils, a program of probe piles across the site is often used to determine variable pile order lengths. Probe piles are particularly useful when driving concrete piles. The pile penetration depth (i.e., length) used to estimate quantities for the contract should also consider requirements to satisfy other design considerations, including service and extreme event limit states, as well as minimum pile penetration requirements for lateral stability, uplift, downdrag, scour, group settlement, etc.

One solution to the problem of predicting pile length is the use of a preliminary test program at the site. Such a program can range from a very simple operation of driving a few piles to evaluate drivability, to an extensive program where different pile types are driven and static load and dynamic testing is performed. For large projects, such test programs may be very cost effective.

In lieu of local pile driving experience, if a static analysis method is used to estimate the pile length required to achieve the desired nominal resistance for establishment of contract pile quantities, to theoretically account for method bias, the factored resistance used to determine the number of piles required in the pile group may be conservatively equated to the factored resistance estimated using the static analysis method as follows:

$$\phi_{dyn} \times R_n = \phi_{stat} \times R_{nstat} \quad (C10.7.3.3-1)$$

where:

ϕ_{dyn} = the resistance factor for the dynamic method used to verify pile bearing resistance during driving specified in Table 10.5.5.2.3-1

R_n = the nominal pile bearing resistance (kips)

ϕ_{stat} = the resistance factor for the static analysis method used to estimate the pile penetration depth required to achieve the desired bearing resistance specified in Table 10.5.5.2.3-1

R_{nstat} = the predicted nominal resistance from the static analysis method used to estimate the penetration depth required (kips)

Using Eq. C10.7.3.3-1 and solving for R_{nstat} , use the static analysis method to determine the penetration depth required to obtain R_{nstat} .

The resistance factor for the static analysis method inherently accounts for the bias and uncertainty in the static analysis method. However, local experience may dictate that the penetration depth estimated using this approach be adjusted to reflect that experience. Where piles are driven to a well defined firm bearing stratum, the location of the top of bearing stratum will dictate the pile length needed, and Eq. C10.7.3.3-1 is likely not applicable.

Note that R_n is considered to be nominal bearing resistance of the pile needed to resist the applied loads, and is used as the basis for determining the resistance to be achieved during pile driving, R_{ndr} (see Articles 10.7.6 and 10.7.7). R_{nstat} is only used in the static analysis method to estimate the pile penetration depth required.

Note that while there is a theoretical basis to this suggested approach, it can produce apparently erroneous results if attempting to use extremes in static analysis and dynamic methods, e.g., using static load test results and then using the Engineering News formula to control pile driving, or using a very inaccurate static analysis method in combination with dynamic testing and signal matching. Part of the problem is that the available resistance factors have been established in consideration of the risk and consequences of pile foundation failure rather than the risk and consequences of underrunning or overrunning pile quantities. Therefore, the approach provided in Eq. C10.7.3.3-1 should be used cautiously, especially when the difference between the resistance factors for method used to estimate pile penetration depth versus the one used for obtaining the required nominal axial resistance is large.

10.7.3.4—Nominal Axial Resistance Change after Pile Driving

10.7.3.4.1—General

Consideration should be given to the potential for change in the nominal axial pile resistance after the end of pile driving. The effect of soil relaxation or setup should be considered in the determination of nominal axial pile resistance for soils that are likely to be subject to these phenomena.

10.7.3.4.2—Relaxation

If relaxation is possible in the soils at the site the pile shall be tested in re-strike after a sufficient time has elapsed for relaxation to develop.

10.7.3.4.3—Setup

Setup in the nominal axial resistance may be used to support the applied load. Where increase in resistance due to setup is utilized, the existence of setup shall be verified after a specified length of time by re-striking the pile.

C10.7.3.4.1

Soil relaxation is not a common phenomenon but more serious than setup since it represents a reduction in the reliability of the foundation.

Soil setup is a common phenomenon that can provide the opportunity for using larger nominal resistances at no increase in cost. However, it is necessary that the resistance gain be adequately proven. This is usually accomplished by restrike testing with dynamic measurements (Komurka, et. al, 2003).

C10.7.3.4.2

Relaxation is a reduction in axial pile resistance. While relaxation typically occurs at the pile tip, it can also occur along the sides of the pile (Morgano and White, 2004). It can occur in dense sands or sandy silts and in some shales. Relaxation in the sands and silts will usually develop fairly quickly after the end of driving (perhaps in only a few minutes or hours) as a result of the return of the reduced pore pressure induced by dilation of the dense sands during driving. In some shales, relaxation occurs during the driving of adjacent piles and that will be immediate. There are other shales where the pile penetrates the shale and relaxation requires perhaps as much as two weeks to develop. In some cases, the amount of relaxation can be large.

C10.7.3.4.3

Setup is an increase in the nominal axial resistance that develops over time predominantly along the pile shaft. Pore pressures increase during pile driving due to a reduction of the soil volume, reducing the effective stress and the shear strength. Setup may occur rapidly in cohesionless soils and more slowly in finer grained soils as excess pore water pressures dissipate. In some clays, setup may continue to develop over a period of weeks and even months, and in large pile groups it can develop even more slowly.

Setup, sometimes called “pile freeze,” can be used to carry applied load, providing the opportunity for using larger pile nominal axial resistances, if it can be proven. Signal matching analysis of dynamic pile measurements made at the end of driving and later in re-strike can be an effective tool in evaluating and quantifying setup. (Komurka et al., 2003; Bogard and Matlock, 1990).

If a wave equation or dynamic formula is used to determine the nominal pile bearing resistance on re-strike, care should be used as these approaches require accurate blow count measurement which is inherently difficult at the beginning of redrive (BOR). Furthermore, the resistance factors provided in Table 10.5.5.2.3-1 for driving formulas were developed for end of driving conditions and empirically have been developed based on the assumption that soil setup will occur. See Article C10.5.5.2.3 for additional discussion on this issue.

Higher degrees of confidence for the assessment of setup effects are provided by dynamic measurements of pile driving with signal matching analyses or static load tests after a sufficient wait time following pile installation.

The restrike time and frequency should be based on the time dependent strength change characteristics of the soil. The following restrike durations are recommended:

Soil Type	Time Delay until Restrike
Clean Sands	1 day
Silty Sands	2 days
Sandy Silts	3-5 days
Silts and Clays	7-14 days*
Shales	7 days

* Longer times are sometimes required.

Specifying a restrike time for friction piles in fine grained soils which is too short may result in pile length overruns.

10.7.3.5—Groundwater Effects and Buoyancy

Nominal axial resistance shall be determined using the groundwater level consistent with that used to calculate the effective stress along the pile sides and tip. The effect of hydrostatic pressure shall be considered in the design.

C10.7.3.5

Unless the pile is bearing on rock, the bearing resistance is primarily dependent on the effective surcharge that is directly influenced by the groundwater level. For drained loading conditions, the vertical effective stress is related to the groundwater level and thus it affects pile axial resistance. Lateral resistance may also be affected.

Buoyant forces may also act on a hollow pile or unfilled casing if it is sealed so that water does not enter the pile. During pile installation, this may affect the driving resistance (blow count) observed, especially in very soft soils.

For design purposes, anticipated changes in the groundwater level during construction and over the life of the structure should be considered with regard to its effect on pile resistance and constructability.

10.7.3.6—Scour

The effect of scour shall be considered in determining the minimum pile embedment and the required nominal driving resistance, R_{ndr} . The pile foundation shall be designed so that the pile penetration after the design scour event satisfies the required nominal axial and lateral resistance.

C10.7.3.6

The piles will need to be driven to the required nominal bearing resistance plus the side resistance that will be lost due to scour. The nominal resistance of the remaining soil is determined through field verification. The pile is driven to the required nominal bearing resistance plus the magnitude of the side resistance lost as a result of scour, considering the prediction method bias.

Another approach that may be used takes advantage of dynamic measurements. In this case, the static analysis method is used to determine an estimated length. During the driving of test piles, the side resistance component of the bearing resistance of pile in the scourable material may be determined by a signal matching analysis of the restrike dynamic measurements obtained when the pile tip is below the scour elevation. The material below the scour elevation must provide the required nominal resistance after scour occurs.

The resistance factors shall be those used in the design without scour. The side resistance of the material lost due to scour should be determined using a static analysis and it should not be factored, but consideration should be given to the bias of the static analysis method used to predict resistance. Method bias is discussed in Article 10.7.3.3.

In some cases, the flooding stream will carry debris that will induce horizontal loads on the piles.

The pile foundation shall be designed to resist debris loads occurring during the flood event in addition to the loads applied from the structure.

Additional information regarding pile design for scour is provided in Hannigan et al. (2006).

10.7.3.7—Downdrag

The foundation should be designed so that the available factored geotechnical resistance is greater than the factored loads applied to the pile, including the downdrag, at the strength limit state. The nominal pile resistance available to support structure loads plus downdrag shall be estimated by considering only the positive side and tip resistance below the lowest layer contributing to the downdrag. The pile foundation shall be designed to structurally resist the downdrag plus structure loads.

In the instance where it is not possible to obtain adequate geotechnical resistance below the lowest layer contributing to downdrag, e.g., piles supported by side resistance, to fully resist the downdrag, or if it is anticipated that significant deformation will be required to mobilize the geotechnical resistance needed to resist the factored loads including the downdrag load, the structure should be designed to tolerate the settlement resulting from the downdrag and the other applied loads as specified in Article 10.7.2.5.

C10.7.3.7

The static analysis procedures in Article 10.7.3.8.6 may be used to estimate the available pile nominal resistance to withstand the downdrag plus structure loads.

Nominal resistance may also be estimated using an instrumented static load test or dynamic testing during restrike with signal matching, provided the side resistance within the zone contributing to downdrag is subtracted from the resistance determined from the static load or dynamic test. The side resistance within the zone contributing to downdrag may be estimated using the static analysis methods specified in Article 10.7.3.8.6, from restrike signal matching analysis, or from instrumented static pile load test results. Note that the static analysis method may have a bias, on average over or under predicting the side resistance. The bias of the method selected to estimate the skin friction should be taken into account as described in Article C10.7.3.3.

Pile design for downdrag is illustrated in Figure C10.7.3.7-1.

where:

R_{Sdd} = side resistance which must be overcome during driving through downdrag zone (kips)

$Q_p = \sum \gamma_i Q_i$ = factored load per pile, excluding downdrag load (kips)

DD = downdrag load per pile (kips)

$D_{est.}$ = estimated pile length needed to obtain desired nominal resistance per pile (ft)

Φ_{dyn} = resistance factor, assuming that a dynamic method is used to estimate nominal pile resistance during installation of the pile (if a static analysis method is used instead, use Φ_{stat})

γ_p = load factor for downdrag

The summation of the factored loads ($\sum \gamma_i Q_i$) should be less than or equal to the factored resistance ($\Phi_{dyn} R_n$). Therefore, the nominal resistance R_n should be greater than or equal to the sum of the factored loads divided by the resistance factor Φ_{dyn} . The nominal bearing resistance (kips) of the pile needed to resist the factored loads, including downdrag, is therefore taken as:

$$R_n = \frac{(\sum \gamma_i Q_i)}{\Phi_{dyn}} + \frac{\gamma_p DD}{\Phi_{dyn}} \quad (C10.7.3.7-1)$$

The total nominal driving resistance, R_{ndr} (kips), needed to obtain R_n , accounting for the side resistance that must be overcome during pile driving that does not contribute to the nominal resistance of the pile, is taken as:

$$R_{ndr} = R_{Sdd} + R_n \quad (C10.7.3.7-2)$$

where:

R_{ndr} = nominal pile driving resistance required (kips)

Note that R_{Sdd} remains unfactored in this analysis to determine R_{ndr} .

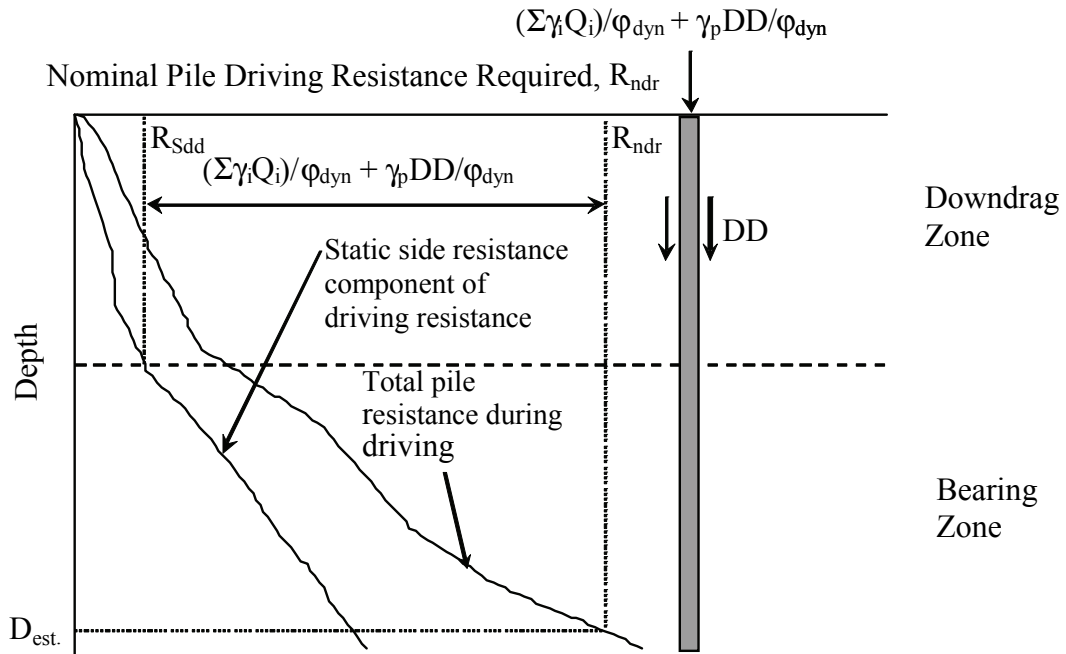

Figure C10.7.3.7-1—Design of Pile Foundations for Downtag

10.7.3.8—Determination of Nominal Bearing Resistance for Piles

10.7.3.8.1—General

Nominal pile bearing resistance should be field verified during pile installation using static load tests, dynamic tests, wave equation analysis, or dynamic formula. The resistance factor selected for design shall be based on the method used to verify pile bearing resistance as specified in Article 10.5.5.2.3. The production piles shall be driven to the minimum blow count determined from the static load test, dynamic test, wave equation, or dynamic formula and, if required, to a minimum penetration needed for uplift, scour, lateral resistance, or other requirements as specified in Article 10.7.6. If it is determined that static load testing is not feasible and dynamic methods are unsuitable for field verification of nominal bearing resistance, the piles shall be driven to the tip elevation determined from the static analysis, and to meet other limit states as required in Article 10.7.6.

C10.7.3.8.1

This Article addresses the determination of the nominal bearing (compression) resistance needed to meet strength limit state requirements, using factored loads and factored resistance values. From this design step, the number of piles and pile nominal resistance needed to resist the factored loads applied to the foundation are determined. Both the loads and resistance values are factored as specified in Articles 3.4.1 and 10.5.5.2.3, respectively, for this determination.

In most cases, the nominal resistance of production piles should be controlled by driving to a required blow count. In a few cases, usually piles driven into cohesive soils with little or no toe resistance and very long wait times to achieve the full pile resistance increase due to soil setup, piles may be driven to depth. However, even in those cases, a pile may be selected for testing after a sufficient waiting period, using either a static load test or a dynamic test.

In cases where the project is small and the time to achieve soil setup is large compared with the production time to install all of the piles, no field testing for the verification of nominal resistance may be acceptable.

10.7.3.8.2—Static Load Test

If a static pile load test is used to determine the pile nominal axial resistance, the test shall not be performed less than 5 days after the test pile was driven unless approved by the Engineer. The load test shall follow the procedures specified in ASTM D1143, and the loading procedure should follow the Quick Load Test Procedure.

Unless specified otherwise by the Engineer, the nominal bearing resistance shall be determined from the test data as follows:

- For piles 24 in. or less in diameter (length of side for square piles), the Davisson Method;
- For piles larger than 36 in. in diameter (length of side for square piles), at a pile top movement, s_f (in.), as determined from Eq. 10.7.3.8.2-1; and
- For piles greater than 24 in. but less than 36 in. in diameter, criteria to determine the nominal bearing resistance that is linearly interpolated between the criteria determined at diameters of 24 and 36 in.

$$s_f = \frac{QL}{12AE} + \frac{B}{2.5} \quad (10.7.3.8.2-1)$$

where:

Q = test load (kips)

L = pile length (ft)

A = pile cross-sectional area (ft²)

E = pile modulus (ksi)

B = pile diameter (length of side for square piles) (ft)

Driving criteria should be established in consideration of the static load test results.

10.7.3.8.3—Dynamic Testing

Dynamic testing shall be performed according to the procedures given in ASTM D4945. If possible, the dynamic test should be performed as a restrike test if the Engineer anticipates significant time dependent strength

C10.7.3.8.2

The Quick Load Test Procedure is preferred because it avoids problems that frequently arise when performing a static load test that cannot be completed within an eight-hour period. Tests that extend over a longer period are difficult to perform due to the limited number of experienced personnel that are usually available. The Quick Load Test has proven to be easily performed in the field and the results usually are satisfactory. Static load tests should be conducted to failure whenever possible and practical to extract the maximum information, particularly when correlating with dynamic tests or static analysis methods. However, if the formation in which the pile is installed may be subject to significant creep settlement, alternative procedures provided in ASTM D1143 should be considered.

The Davisson Method to determine nominal bearing resistance evaluation is performed by constructing a line on the static load test curve that is parallel to the elastic compression line of the pile. The elastic compression line is calculated by assuming equal compressive forces are applied to the pile ends. The elastic compression line is offset by a specified amount of displacement. The Davisson Method is illustrated in Figure C10.7.3.8.2-1 and described in more detail in Hannigan et al. (2006).

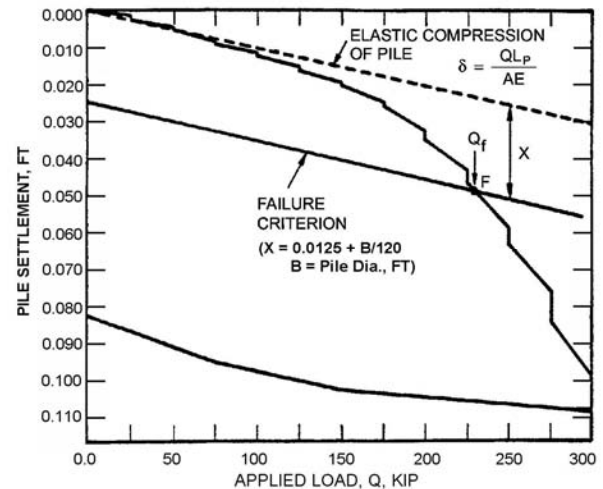

Figure C10.7.3.8.2-1—Alternate Method Load Test Interpretation (Cheney and Chassie, 2000, modified after Davisson, 1972)

For piles with large cross-sections, i.e., diameters greater than 24 in., the Davisson Method will under predict the nominal pile bearing resistance.

Development of driving criteria in consideration of static load test results is described in Hannigan, et al. (2006).

C10.7.3.8.3

The dynamic test may be used to establish the driving criteria at the beginning of production driving. A signal matching analysis (Rausche et al., 1972) of the dynamic test data should always be used

change. The nominal pile bearing resistance shall be determined by a signal matching analysis of the dynamic pile test data if the dynamic test is used to establish the driving criteria.

to determine bearing resistance if a static load test is not performed. See Hannigan et al. (2006) for a description of and procedures to conduct a signal matching analysis. Re-strike testing should be performed if setup or relaxation is anticipated.

For example, note that it may not be possible to adjust the dynamic measurements with signal matching analysis to match the static load test results if the driving resistance at the time the dynamic measurement is taken is too large, i.e., the pile set per hammer blow is too small. In this case, adequate hammer energy is not reaching the pile tip to assess end bearing and produce an accurate match, though in such cases, the prediction will usually be very conservative. In general, a tip movement (pile set) of 0.10 to 0.15 in. is needed to provide an accurate signal matching analysis. See Hannigan, et al. (2006) for additional guidance on this issue.

In cases where a significant amount of soil setup occurs and the set at the beginning of redrive (BOR) is less than 0.10 inch per blow, a more accurate nominal resistance may be obtained by combining the end bearing determined using the signal matching analysis obtained for the end of driving (EOD) with the signal matching analysis for the shaft resistance at the beginning of redrive.

Dynamic testing and interpretation of the test data should only be performed by certified, experienced testers.

10.7.3.8.4—Wave Equation Analysis

If a wave equation analysis is to be used to establish the driving criteria, it shall be performed based on the hammer and pile driving system to be used for pile installation.

If a wave equation analysis is used for the determination of the nominal bearing resistance, then the driving criterion (blow count) may be the value taken either at the end of driving (EOD) or at the beginning of redrive (BOR). The latter should be used where the soils exhibit significant strength changes (setup or relaxation) with time. When restrrike (i.e., BOR) blow counts are taken, the hammer shall be warmed up prior to restrrike testing and the blow count shall be taken as accurately as possible for the first inch of restrrike.

If the wave equation is used to assess the potential for pile damage, driving stresses shall not exceed the values obtained in Article 10.7.8, using the resistance factors specified or referred to in Table 10.5.5.2.3-1. Furthermore, the blow count needed to obtain the maximum driving resistance anticipated shall be less than the maximum value established based on the provisions in Article 10.7.8.

C10.7.3.8.4

Note that without dynamic test results with signal matching analysis and/or pile load test data (see Articles 10.7.3.8.2 and 10.7.3.8.3), some judgment is required to use the wave equation to predict the pile bearing resistance. Unless experience in similar soils exists, the recommendations of the software provider should be used for dynamic resistance input. Key soil input values that affect the predicted nominal resistance include the soil damping and quake values, the skin friction distribution, e.g., such as could be obtained from a static pile bearing analysis, and the anticipated amount of soil setup or relaxation. The actual hammer performance is a variable that can only be accurately assessed through dynamic measurements, though field observations such as hammer stroke or measured ram velocity can and should be used to improve the accuracy of the wave equation prediction.

In general, improved prediction accuracy of nominal bearing resistance is obtained when targeting the driving criteria at BOR conditions, if soil setup or relaxation is anticipated. Using the wave equation to predict nominal bearing resistance from EOD blow counts requires that an accurate estimate of the time-dependent changes in bearing resistance due to soil setup or relaxation be made. This is generally difficult to do unless site-specific, longer-term measurements of bearing resistance from static load tests or dynamic measurements with signal matching are available. Hence, driving criteria based on BOR measurements are recommended when using the wave equation for driving criteria development.

10.7.3.8.5—Dynamic Formula

If a dynamic formula is used to establish the driving criterion, the FHWA Gates Formula (Eq. 10.7.3.8.5-1) should be used. The nominal pile resistance as measured during driving using this method shall be taken as:

$$R_{ndr} = 1.75\sqrt{E_d} \log_{10}(10N_b) - 100 \quad (10.7.3.8.5-1)$$

where:

R_{ndr} = nominal pile driving resistance measured during pile driving (kips)

E_d = developed hammer energy. This is the kinetic energy in the ram at impact for a given blow. If ram velocity is not measured, it may be assumed equal to the potential energy of the ram at the height of the stroke, taken as the ram weight times the actual stroke (ft-lb)

N_b = Number of hammer blows for 1.0 in. of pile permanent set (blows/in.)

The Engineering News formula, modified to predict a nominal bearing resistance, may be used. The nominal pile resistance using this method shall be taken as:

$$R_{ndr} = \frac{12E_d}{(s + 0.1)} \quad (10.7.3.8.5-2)$$

where:

R_{ndr} = nominal pile resistance measured during driving (kips)

E_d = developed hammer energy. This is the kinetic energy in the ram at impact for a given blow. If ram velocity is not measured, it may be assumed equal to the potential energy of the ram at the height of the stroke, taken as the ram weight times the stroke (ft-kips)

s = pile permanent set, (in.)

If a dynamic formula other than those provided herein is used, it shall be calibrated based on measured load test results to obtain an appropriate resistance factor, consistent with Article C10.5.5.2.

If a drivability analysis is not conducted, for steel piles, design stresses shall be limited as specified in Article 6.15.2.

A wave equation analysis should also be used to evaluate pile drivability during design.

C10.7.3.8.5

It is preferred to use more accurate methods such as wave equation or dynamic testing with signal matching to establish driving criteria (i.e., blow count). However, driving formulas have been in use for many years. Therefore, driving formulas are provided as an option for the development of driving criteria.

Two dynamic formulas are provided here for the Engineer. If a dynamic formula is used for either determination of the nominal resistance or the driving criterion, the FHWA Modified Gates formula is preferred over the Engineering News formula. It is discussed further in the Design and Construction of Driven Pile Foundations (Hannigan et al., 2006). Note that the units in the FHWA Gates formula are not consistent. The specified units in Eq. 10.7.3.8.5-1 must be used.

The Engineering News formula in its traditional form contains a factor of safety of 6.0. For LRFD applications, to produce a nominal resistance, the factor of safety has been removed. As is true of the FHWA Gates formula, the units specified in Eq. 10.7.3.8.5-2 must be used for the Engineering News formula. See Allen (2005, 2007) for additional discussion on the development of the Engineering News formula and its modification to produce a nominal resistance.

Driving formula should only be used to determine end of driving blow count criteria. These driving formula are empirically based on pile load test results, and therefore inherently include some degree of soil setup or relaxation (see Allen, 2007).

Dynamic formulas should not be used when the required nominal resistance exceeds 600 kips.

As the required nominal bearing resistance increases, the reliability of dynamic formulas tends to decrease. The FHWA Gates formula tends to underpredict pile nominal resistance at higher resistances. The Engineering News formula tends to become unconservative as the nominal pile resistance increases. If other driving formulas are used, the limitation on the maximum driving resistance to be used should be based upon the limits for which the data is considered reliable, and any tendency of the formula to over or under predict pile nominal resistance.

10.7.3.8.6—Static Analysis

10.7.3.8.6a—General

Where a static analysis prediction method is used to determine pile installation criteria, i.e., for bearing resistance, the nominal pile resistance shall be factored at the strength limit state using the resistance factors in Table 10.5.5.2.3-1 associated with the method used to compute the nominal bearing resistance of the pile. The factored nominal bearing resistance of piles, R_R , may be taken as:

$$R_R = \phi R_n \quad (10.7.3.8.6a-1)$$

or:

$$R_R = \phi R_n = \phi_{stat} R_p + \phi_{stat} R_s \quad (10.7.3.8.6a-2)$$

in which:

$$R_p = q_p A_p \quad (10.7.3.8.6a-3)$$

$$R_s = q_s A_s \quad (10.7.3.8.6a-4)$$

where:

ϕ_{stat} = resistance factor for the bearing resistance of a single pile specified in Article 10.5.5.2.3

R_p = pile tip resistance (kips)

R_s = pile side resistance (kips)

q_p = unit tip resistance of pile (ksf)

q_s = unit side resistance of pile (ksf)

A_s = surface area of pile side (ft²)

A_p = area of pile tip (ft²)

Both total stress and effective stress methods may be used, provided the appropriate soil strength parameters are available. The resistance factors for the side resistance and tip resistance, estimated using these methods, shall be as specified in Table 10.5.5.2.3-1. The limitations of each method as described in Article C10.5.5.2.3 should be applied in the use of these static analysis methods.

C10.7.3.8.6a

While the most common use of static analysis methods is solely for estimating pile quantities, a static analysis may be used to establish pile installation criteria if dynamic methods are determined to be unsuitable for field verification of nominal bearing resistance. This is applicable on projects where pile quantities are relatively small, pile loads are relatively low, and/or where the setup time is long so that re-strike testing would require an impractical wait-period by the Contractor on the site, e.g., soft silts or clays where a large amount of setup is anticipated.

For use of static analysis methods for contract pile quantity estimation, see Article 10.7.3.3.

10.7.3.8.6b— α -Method

C10.7.3.8.6b

The α -method, based on total stress, may be used to relate the adhesion between the pile and clay to the undrained strength of the clay. For this method, the nominal unit side resistance, in ksf, shall be taken as:

$$q_s = \alpha S_u \quad (10.7.3.8.6b-1)$$

where:

S_u = undrained shear strength (ksf)

α = adhesion factor applied to S_u (dim)

The adhesion factor for this method, α , shall be assumed to vary with the value of the undrained strength, S_u , as shown in Figure 10.7.3.8.6b-1.

The α -method has been used for many years and gives reasonable results for both displacement and nondisplacement piles in clay.

In general, this method assumes that a mean value of S_u will be used. It may not always be possible to establish a mean value, as in many cases, data are too limited to reliably establish the mean value. The Engineer should apply engineering judgment and local experience as needed to establish an appropriate value for design (see Article C10.4.6).

For H-piles, the perimeter or “box” area should generally be used to compute the surface area of the pile side.

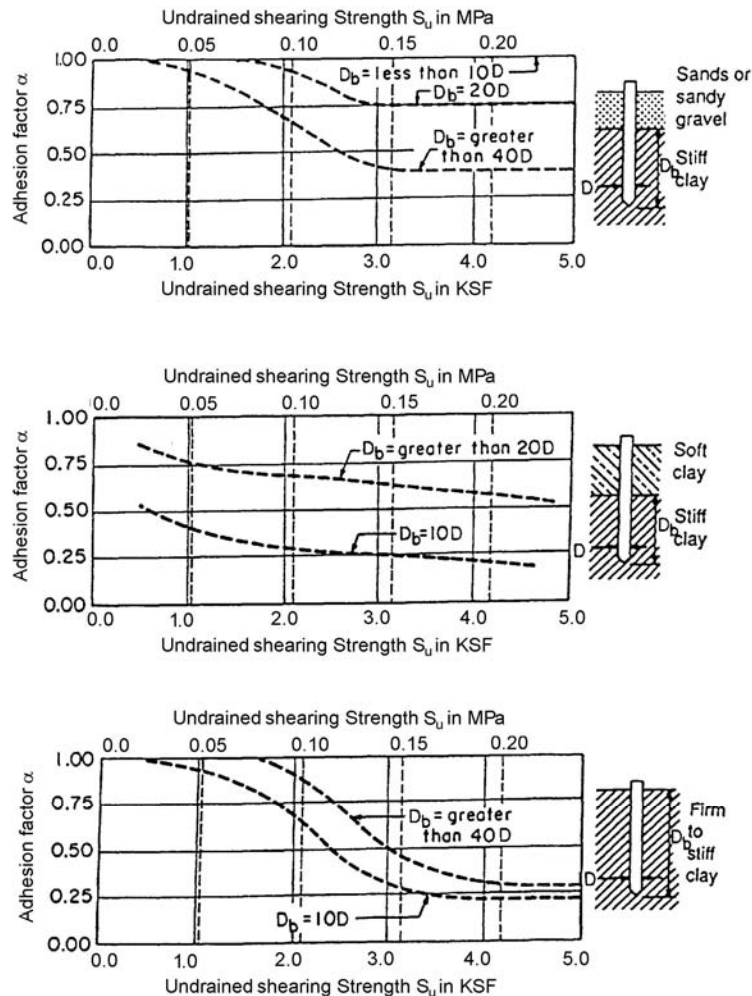

Figure 10.7.3.8.6b-1—Design Curves for Adhesion Factors for Piles Driven into Clay Soils after Tomlinson (1980)

10.7.3.8.6c— β -Method

The β -method, based on effective stress, may be used for predicting side resistance of prismatic piles. The nominal unit skin friction for this method, in ksf, shall be related to the effective stresses in the ground as:

$$q_s = \beta \sigma'_v \tag{10.7.3.8.6c-1}$$

where:

σ'_v = vertical effective stress (ksf)

β = a factor taken from Figure 10.7.3.8.6c-1

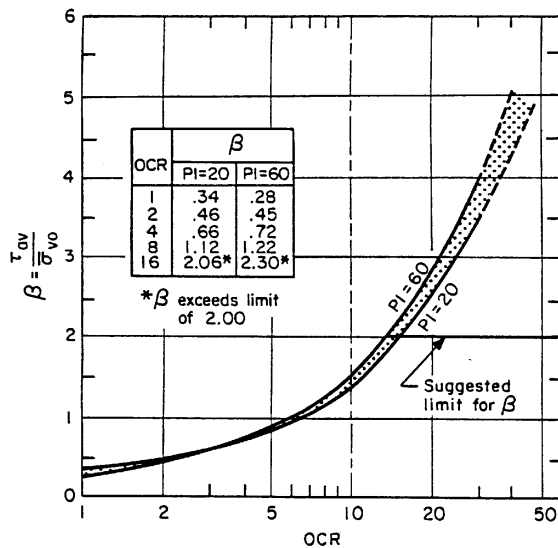

Figure 10.7.3.8.6c-1— β Versus OCR for Displacement Piles after Esrig and Kirby (1979)

10.7.3.8.6d— λ -Method

The λ -method, based on effective stress (though it does contain a total stress parameter), may be used to relate the unit side resistance, in ksf, to passive earth pressure. For this method, the unit skin friction shall be taken as:

$$q_s = \lambda(\sigma'_v + 2S_u) \tag{10.7.3.8.6d-1}$$

where:

$\sigma'_v + 2S_u$ = passive lateral earth pressure (ksf)

σ'_v = the effective vertical stress at midpoint of soil layer under consideration (ksf)

λ = an empirical coefficient taken from Figure 10.7.3.8.6d-1 (dim)

C10.7.3.8.6c

The β -method has been found to work best for piles in normally consolidated and lightly overconsolidated clays. The method tends to overestimate side resistance of piles in heavily overconsolidated soils. Esrig and Kirby (1979) suggested that for heavily overconsolidated clays, the value of β should not exceed two.

C10.7.3.8.6d

The value of λ decreases with pile length and was found empirically by examining the results of load tests on steel pipe piles.

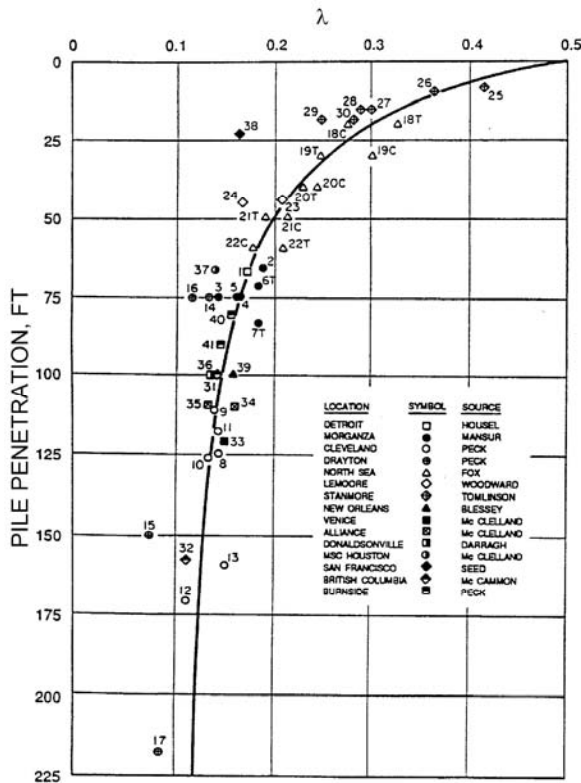

Figure 10.7.3.8.6d-1—λ Coefficient for Driven Pipe Piles after Vijayvergiya and Focht (1972)

10.7.3.8.6e—Tip Resistance in Cohesive Soils

The nominal unit tip resistance of piles in saturated clay, in ksf, shall be taken as:

$$q_p = 9S_u \tag{10.7.3.8.6e-1}$$

where:

S_u = undrained shear strength of the clay near the pile tip (ksf)

10.7.3.8.6f—Nordlund/Thurman Method in Cohesionless Soils

C10.7.3.8.6f

This effective stress method should be applied only to sands and nonplastic silts. The nominal unit side resistance, q_s , for this method, in ksf, shall be taken as:

$$q_s = K_\delta C_F \sigma'_v \frac{\sin(\delta + \omega)}{\cos \omega} \tag{10.7.3.8.6f-1}$$

where:

K_δ = coefficient of lateral earth pressure at mid-point of soil layer under consideration from Figures 10.7.3.8.6f-1 through 10.7.3.8.6f-4 (dim)

Detailed design procedures for the Nordlund/Thurman method are provided in Hammigan et al., (2006). This method was derived based on load test data for piles in sand. In practice, it has been used for gravelly soils as well.

The effective overburden stress is not limited in Eq. 10.7.3.8.6f-1.

For H-piles, the perimeter or “box” area should generally be used to compute the surface area of the pile side.

C_F = correction factor for K_δ when $\delta \neq \phi_f$ from Figure 10.7.3.8.6f-5

σ'_v = effective overburden stress at midpoint of soil layer under consideration (ksf)

δ = friction angle between pile and soil obtained from Figure 10.7.3.8.6f-6 (degrees)

ω = angle of pile taper from vertical (degrees)

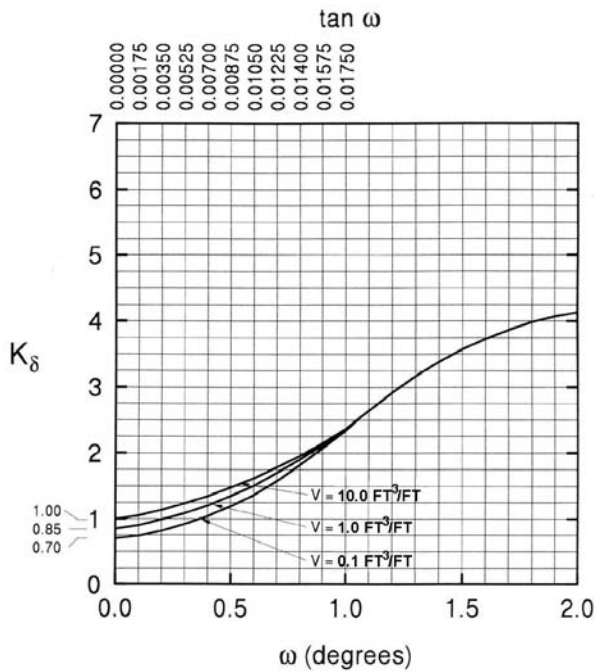

Figure 10.7.3.8.6f-1—Design Curve for Evaluating K_δ for Piles where $\phi_f = 25$ degrees (Hannigan et al., 2006 after Nordlund, 1979)

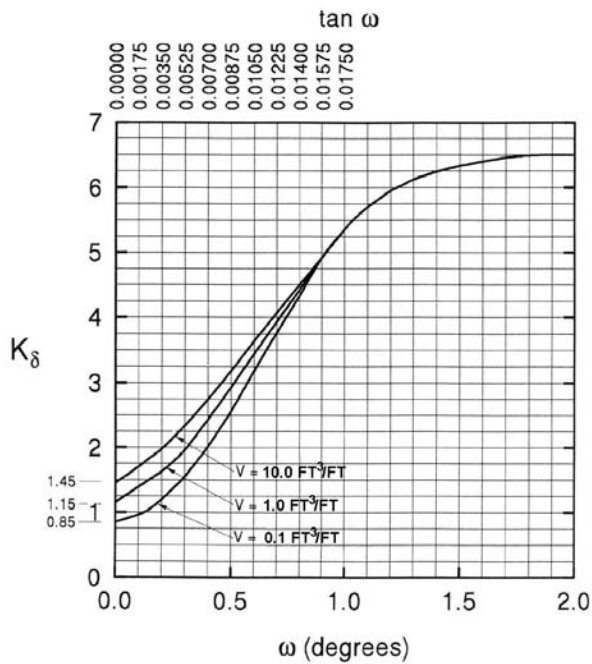

Figure 10.7.3.8.6f-2—Design Curve for Evaluating K_δ for Piles where $\phi_r = 30$ degrees (Hannigan et al., 2006 after Nordlund, 1979)

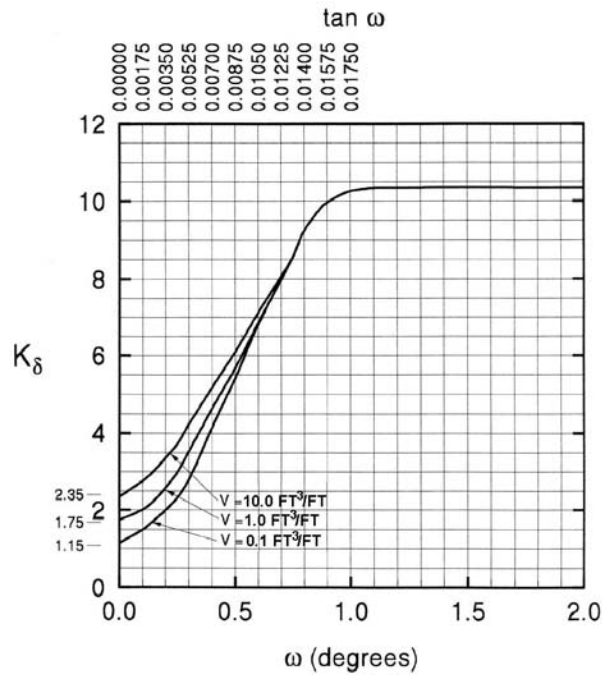

Figure 10.7.3.8.6f-3—Design Curve for Evaluating K_δ for Piles where $\phi_r = 35$ degrees (Hannigan et al., 2006 after Nordlund, 1979)

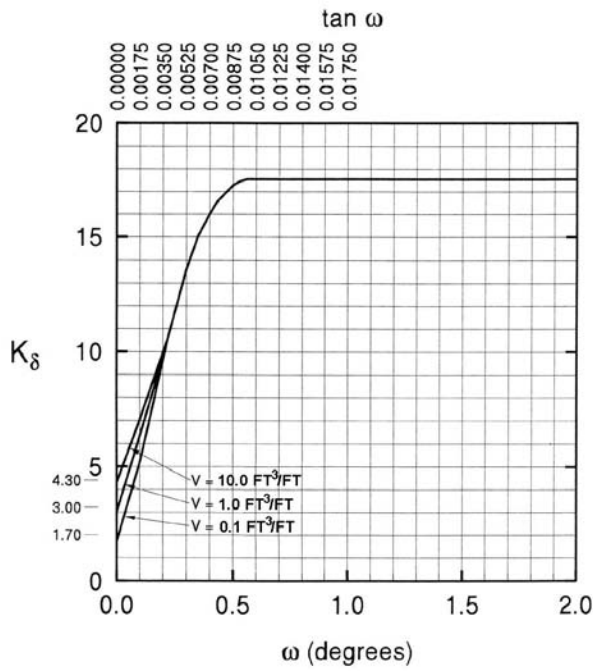

Figure 10.7.3.8.6f-4—Design Curve for Evaluating K_{δ} for Piles where $\phi_r = 40$ degrees (Hannigan et al., 2006 after Nordlund, 1979)

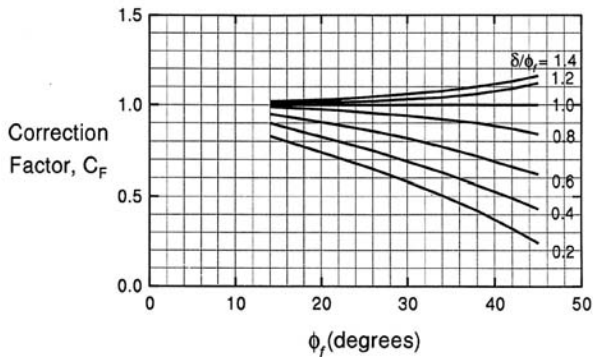

Figure 10.7.3.8.6f-5—Correction Factor for K_{δ} where $\delta \neq \phi_r$ (Hannigan et al., 2006 after Nordlund, 1979)

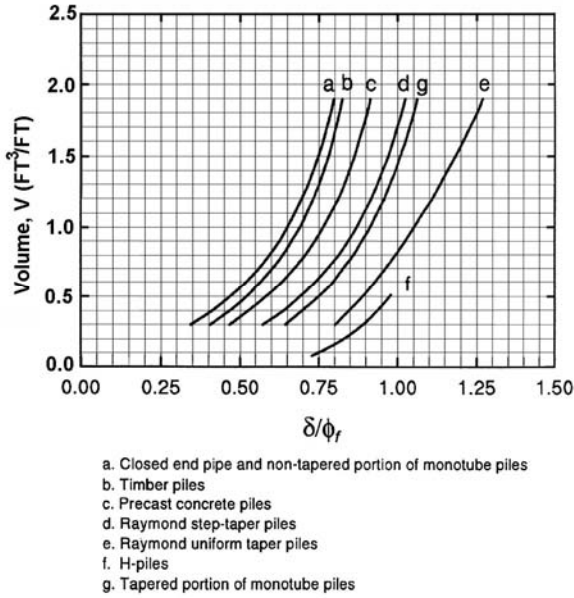

Figure 10.7.3.8.6f-6—Relation of δ/ϕ_f and Pile Displacement, V , for Various Types of Piles (Hannigan et al., 2006 after Nordlund, 1979)

The nominal unit tip resistance, q_p , in ksf by the Nordlund/Thurman method shall be taken as:

$$q_p = \alpha_t N'_q \sigma'_v \leq q_L \quad (10.7.3.8.6f-2)$$

where:

α_t = coefficient from Figure 10.7.3.8.6f-7 (dim)

N'_q = bearing capacity factor from Figure 10.7.3.8.6f-8

σ'_v = effective overburden stress at pile tip (ksf)
 ≤ 3.2 ksf

q_L = limiting unit tip resistance from Figure 10.7.3.8.6f-9

If the friction angle, ϕ_f , is estimated from average, corrected *SPT* blow counts, N_{160} , the N_{160} values should be averaged over the zone from the pile tip to two diameters below the pile tip.

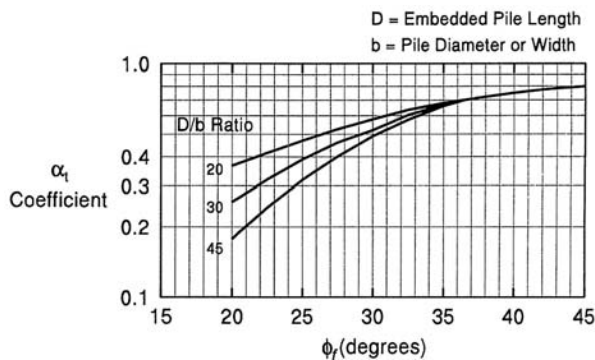

Figure 10.7.3.8.6f-7— α_t Coefficient (Hannigan et al., 2006 modified after Bowles, 1977)

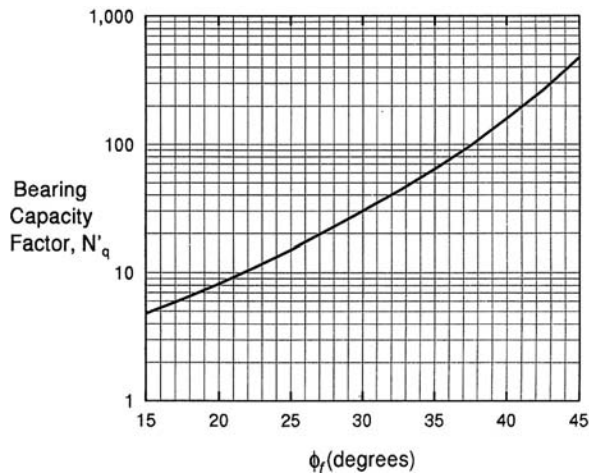

Figure 10.7.3.8.6f-8—Bearing Capacity Factor, N'_q (Hannigan et al., 2006 modified after Bowles, 1977)

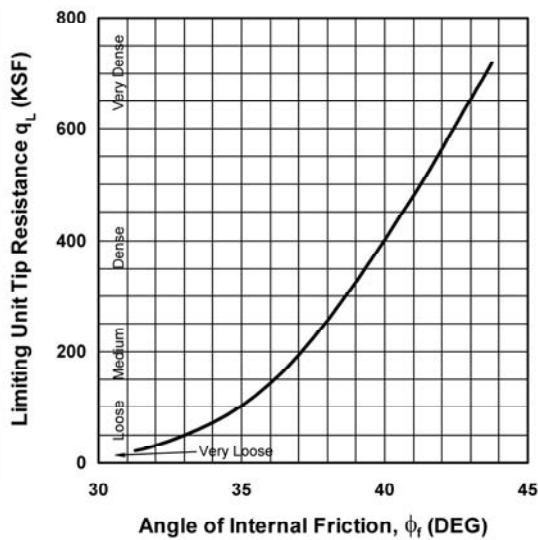

Figure 10.7.3.8.6f-9—Limiting Unit Pile Tip Resistance (Hannigan et al., 2006 after Meyerhof, 1976)

10.7.3.8.6g—Using SPT or CPT in Cohesionless Soils

C10.7.3.8.6g

These methods shall be applied only to sands and nonplastic silts.

The nominal unit tip resistance for the Meyerhof method, in ksf, for piles driven to a depth D_b into a cohesionless soil stratum shall be taken as:

$$q_p = \frac{0.8(N_{160})D_b}{D} \leq q_t \tag{10.7.3.8.6g-1}$$

In-situ tests are widely used in cohesionless soils because obtaining good quality samples of cohesionless soils is very difficult. In-situ test parameters may be used to estimate the tip resistance and side resistance of piles.

Two frequently used in-situ test methods for predicting pile axial resistance are the standard penetration test (SPT) method (Meyerhof, 1976) and the cone penetration test (CPT) method (Nottingham and Schmertmann, 1975).

where:

N_{160} = representative *SPT* blow count near the pile tip corrected for overburden pressure as specified in Article 10.4.6.2.4 (blows/ft)

D = pile width or diameter (ft)

D_b = depth of penetration in bearing strata (ft)

q_ℓ = limiting tip resistance taken as eight times the value of N_{160} for sands and six times the value of N_{160} for nonplastic silt (ksf)

The nominal side resistance of piles in cohesionless soils for the Meyerhof method, in ksf, shall be taken as:

- For driven displacement piles:

$$q_s = \frac{\bar{N}_{160}}{25} \quad (10.7.3.8.6g-2)$$

- For nondisplacement piles, e.g., steel H-piles:

$$q_s = \frac{\bar{N}_{160}}{50} \quad (10.7.3.8.6g-3)$$

where:

q_s = unit side resistance for driven piles (ksf)

\bar{N}_{160} = average corrected *SPT*-blow count along the pile side (blows/ft)

Tip resistance, q_p , for the Nottingham and Schmertmann method, in ksf, shall be determined as shown in Figure 10.7.3.8.6g-1.

In which:

$$q_p = \frac{q_{c1} + q_{c2}}{2} \quad (10.7.3.8.6g-4)$$

where:

q_{c1} = average q_c over a distance of yD below the pile tip (path a-b-c); sum q_c values in both the downward (path a-b) and upward (path b-c) directions; use actual q_c values along path a-b and the minimum path rule along path b-c; compute q_{c1} for y -values from 0.7 to 4.0 and use the minimum q_{c1} value obtained (ksf)

Displacement piles, which have solid sections or hollow sections with a closed end, displace a relatively large volume of soil during penetration. Nondisplacement piles usually have relatively small cross-sectional areas, e.g., steel H-piles and open-ended pipe piles that have not yet plugged. Plugging occurs when the soil between the flanges in a steel H-pile or the soil in the cylinder of an open-ended steel pipe pile adheres fully to the pile and moves down with the pile as it is driven.

CPT may be used to determine:

- The cone penetration resistance, q_c , which may be used to determine the tip resistance of piles, and
- Sleeve friction, f_s , which may be used to determine the side resistance.

q_{c2} = average q_c over a distance of $8D$ above the pile tip (path c-e); use the minimum path rule as for path b-c in the q_{c1} , computations; ignore any minor “x” peak depressions if in sand but include in minimum path if in clay (ksf)

The minimum average cone resistance between 0.7 and four pile diameters below the elevation of the pile tip shall be obtained by a trial and error process, with the use of the minimum-path rule. The minimum-path rule shall also be used to find the value of cone resistance for the soil for a distance of eight pile diameters above the tip. The two results shall be averaged to determine the pile tip resistance.

The nominal side resistance of piles for this method, in kips, shall be taken as:

$$R_s = K_{s,c} \left[\sum_{i=1}^{N_1} \left(\frac{L_i}{8D_i} \right) f_{si} a_{si} h_i + \sum_{i=1}^{N_2} f_{si} a_{si} h_i \right] \quad (10.7.3.8.6g-5)$$

where:

$K_{s,c}$ = correction factors: K_c for clays and K_s for sands from Figure 10.7.3.8.6g-2 (dim)

L_i = depth to middle of length interval at the point considered (ft)

D_i = pile width or diameter at the point considered (ft)

f_{si} = unit local sleeve friction resistance from CPT at the point considered (ksf)

a_{si} = pile perimeter at the point considered (ft)

h_i = length interval at the point considered (ft)

N_1 = number of intervals between the ground surface and a point $8D$ below the ground surface

N_2 = number of intervals between $8D$ below the ground surface and the tip of the pile

This process is described in Nottingham and Schmertmann (1975).

For a pile of constant cross-section (nontapered), Eq. 10.7.3.8.6g-5 can be written as:

$$R_s = K_{s,c} \left[\frac{a_s}{8D} \sum_{i=1}^{N_1} L_i f_{si} h_i + a_s \sum_{i=1}^{N_2} f_{si} h_i \right] \quad (C10.7.3.8.6g-1)$$

If, in addition to the pile being prismatic, f_s is approximately constant at depths below $8D$, Eq. C10.7.3.8.6g-1 can be simplified to:

$$R_s = K_{s,c} [a_s f_s (Z - 4D)] \quad (C10.7.3.8.6g-2)$$

where:

Z = total embedded pile length (ft)

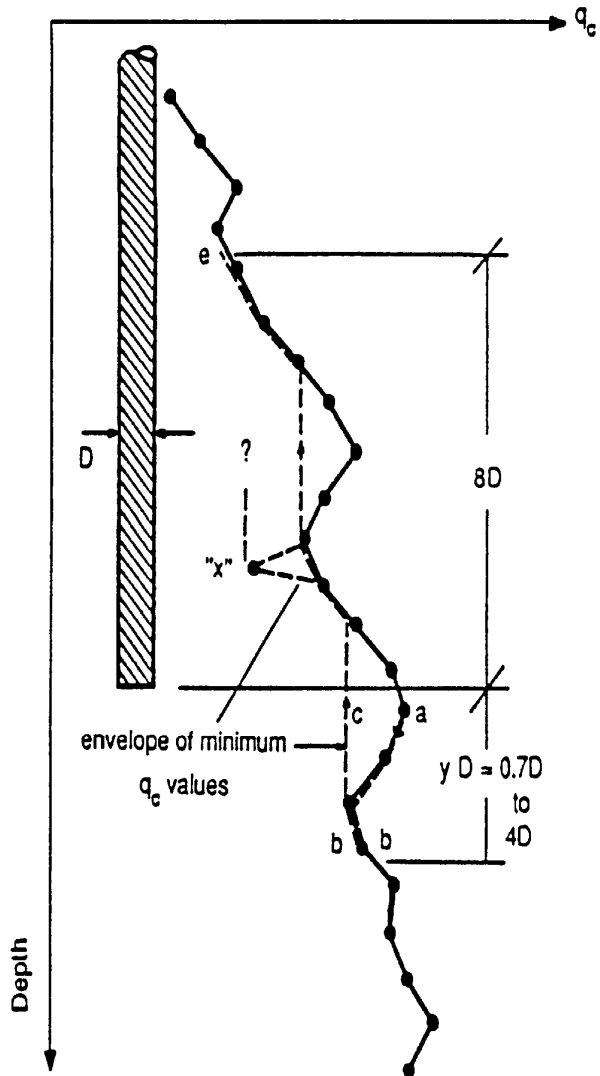

Figure 10.7.3.8.6g-1—Pile End-Bearing Computation Procedure after Nottingham and Schmertmann (1975)

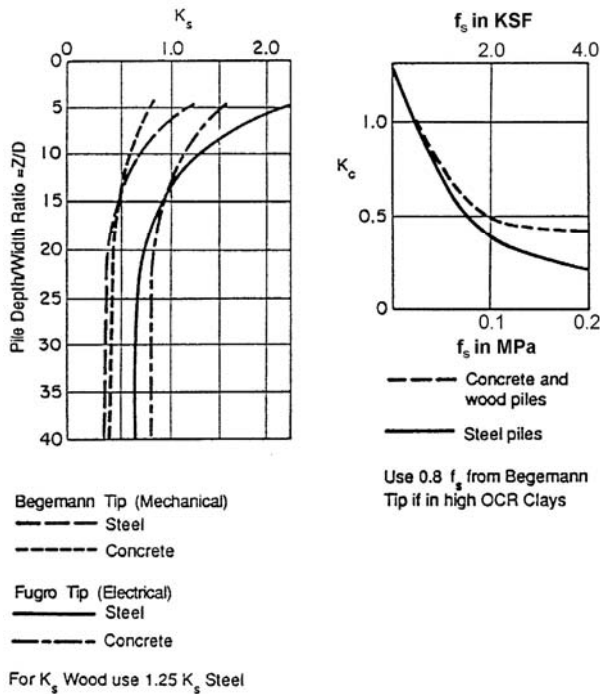

Figure 10.7.3.8.6g-2 —Side Resistance Correction Factors K_s and K_c after Nottingham and Schmertmann (1975)

10.7.3.9—Resistance of Pile Groups in Compression

C10.7.3.9

For pile groups in clay, the nominal bearing resistance of the pile group shall be taken as the lesser of:

- The sum of the individual nominal resistances of each pile in the group, or
- The nominal resistance of an equivalent pier consisting of the piles and the block of soil within the area bounded by the piles.

If the cap is not in firm contact with the ground and if the soil at the surface is soft, the individual nominal resistance of each pile shall be multiplied by an efficiency factor η , taken as:

- $\eta = 0.65$ for a center-to-center spacing of 2.5 diameters,
- $\eta = 1.0$ for a center-to-center spacing of 6.0 diameters.

For intermediate spacings, the value of η should be determined by linear interpolation.

The equivalent pier approach checks for block failure and is generally only applicable for pile groups within cohesive soils. For pile groups in cohesionless soils, the sum of the nominal resistances of the individual piles always controls the group resistance.

When analyzing the equivalent pier, the full shear strength of the soil should be used to determine the friction resistance. The total base area of the equivalent pier should be used to determine the end bearing resistance.

In cohesive soils, the nominal resistance of a pile group depends on whether the cap is in firm contact with the ground beneath. If the cap is in firm contact, the soil between the pile and the pile group behave as a unit.

At small pile spacings, a block type failure mechanism may prevail, whereas individual pile failure may occur at larger pile spacings. It is necessary to check for both failure mechanisms and design for the case that yields the minimum capacity.

For a pile group of width X , length Y , and depth Z , as shown in Figure C10.7.3.9-1, the bearing capacity for block failure, in kips, is given by:

If the cap is in firm contact with the ground, no reduction in efficiency shall be required. If the cap is not in firm contact with the ground and if the soil is stiff, no reduction in efficiency shall be required.

The nominal bearing resistance of pile groups in cohesionless soil shall be the sum of the resistance of all the piles in the group. The efficiency factor, η , shall be 1.0 where the pile cap is or is not in contact with the ground for a center-to-center pile spacing of 2.5 diameters or greater. The resistance factor is the same as that for single piles, as specified in Table 10.5.5.2.3-1.

For pile groups in clay or sand, if a pile group is tipped in a strong soil deposit overlying a weak deposit, the block bearing resistance shall be evaluated with consideration to pile group punching as a group into the underlying weaker layer. The methods in Article 10.6.3.1.2a of determining bearing resistance of a spread footing in a strong layer overlying a weaker layer shall apply, with the notional footing located as shown in Article 10.7.2.3.

$$Q_g = (2X + 2Y)Z\bar{S}_u + XYN_c S_u \quad (\text{C10.7.3.9-1})$$

in which:

$$\text{for } \frac{Z}{X} \leq 2.5:$$

$$N_c = 5 \left(1 + \frac{0.2X}{Y} \right) \left(1 + \frac{0.2Z}{X} \right) \quad (\text{C10.7.3.9-2})$$

$$\text{for } \frac{Z}{X} > 2.5:$$

$$N_c = 7.5 \left(1 + \frac{0.2X}{Y} \right) \quad (\text{C10.7.3.9-3})$$

where:

\bar{S}_u = average undrained shear strength along the depth of penetration of the piles (ksf)

S_u = undrained shear strength at the base of the group (ksf)

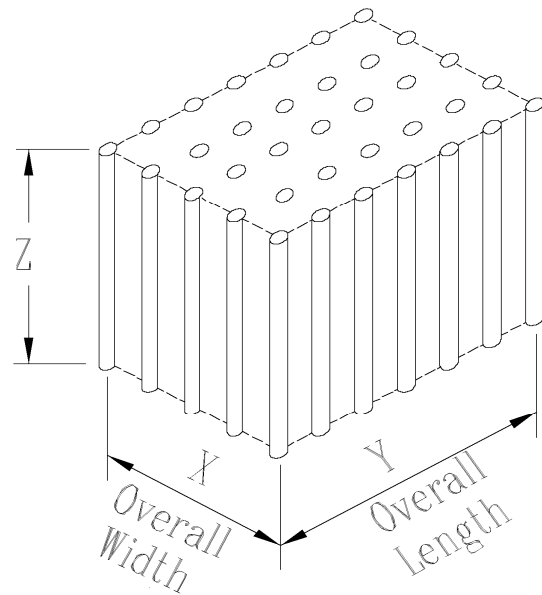

Figure C10.7.3.9-1—Pile Group Acting as a Block Foundation

10.7.3.10—Uplift Resistance of Single Piles

Uplift on single piles shall be evaluated when tensile forces are present. The factored nominal tensile resistance of the pile due to soil failure shall be greater than the factored pile loads.

The nominal uplift resistance of a single pile should be estimated in a manner similar to that for estimating the side resistance of piles in compression specified in Article 10.7.3.8.6.

Factored uplift resistance in kips shall be taken as:

$$R_R = \phi R_n = \phi_{up} R_s \quad (10.7.3.10-1)$$

where:

R_s = nominal uplift resistance due to side resistance (kips)

ϕ_{up} = resistance factor for uplift resistance specified in Table 10.5.5.2.3-1

Nominal uplift resistance of single piles may be determined by static load test or by dynamic test with signal matching. If a static uplift test is to be performed, it shall follow the procedures specified in ASTM D 3689. Dynamic tests with signal matching, if conducted, shall be performed as specified in Article 10.7.3.8.3. If dynamic tests with signal matching are used to determine uplift, a maximum of 80 percent of the uplift determined from the dynamic test should be used.

The static pile uplift load test(s) should be used to calibrate the static analysis method, i.e., back calculate soil properties, to adjust the calculated uplift resistance for variations in the stratigraphy. The minimum penetration criterion to obtain the desired uplift resistance should be based on the calculated uplift resistance using the static pile uplift load test results.

10.7.3.11—Uplift Resistance of Pile Groups

The nominal uplift resistance of pile groups shall be evaluated when the foundation is subjected to uplift loads.

Pile group factored uplift resistance, in kips, shall be taken as:

$$R_R = \phi R_n = \phi_{ug} R_{ug} \quad (10.7.3.11-1)$$

where:

ϕ_{ug} = resistance factor specified in Table 10.5.5.2.3-1

R_{ug} = nominal uplift resistance of the pile group (kips)

C10.7.3.10

The factored load effect acting on any pile in a group may be estimated using the traditional elastic strength of materials procedure for a cross-section under thrust and moment. The cross-sectional properties should be based on the pile as a unit area.

Note that the resistance factor for uplift already is reduced to 80 percent of the resistance factor for static side resistance. Therefore, the side resistance estimated based on Article 10.7.3.8.6 does not need to be reduced to account for uplift effects on side resistance.

Static uplift tests should be evaluated using a modified Davisson Method as described in Hannigan et al. (2006).

If using dynamic tests with signal matching to determine uplift resistance, it may be difficult to separate the measured end bearing resistance from the side resistance acting on the bottom section of the pile, especially if the soil stiffness at the pile tip is not significantly different from the soil stiffness acting on the sides of the pile near the pile tip. If it is not clear what is end bearing and what is side friction near the pile tip, the side resistance acting on the bottom pile element should be ignored when estimating uplift resistance using this method. If the pile length is shorter than 30 ft. in length, caution should be exercised when using dynamic tests with signal matching to estimate uplift.

C10.7.3.11

A net uplift force can act on the foundation. An example of such a load is the construction load induced during the erection of concrete segmental girder bridges.

The nominal uplift resistance, R_{ug} , of a pile group shall be taken as the lesser of:

- The sum of the individual pile uplift resistance, or
- The uplift resistance of the pile group considered as a block.

For pile groups in cohesionless soil, the weight of the block that will be uplifted shall be determined using a spread of load of $1H$ in $4V$ from the base of the pile group taken from Figure 10.7.3.11-1. Buoyant unit weights shall be used for soil below the groundwater level.

In cohesive soils, the block used to resist uplift in undrained shear shall be taken from Figure 10.7.3.11-2. The nominal group uplift resistance may be taken as:

$$R_n = R_{ug} = (2XZ + 2YZ)\bar{S}_u + W_g \quad (10.7.3.11-2)$$

where:

X = width of the group, as shown in Figure 10.7.3.11-2 (ft)

Y = length of the group, as shown in Figure 10.7.3.11-2 (ft)

Z = depth of the block of soil below pile cap taken from Figure 10.7.3.11-2 (ft)

\bar{S}_u = average undrained shear strength along the sides of the pile group (ksf)

W_g = weight of the block of soil, piles, and pile cap (kips)

The resistance factor for the nominal group uplift resistance, R_{ug} , determined as the sum of the individual pile resistances, shall be taken as the same as that for the uplift resistance of single piles as specified in Table 10.5.5.2.3-1.

The resistance factor for the uplift resistance of the pile group considered as a block shall be taken as specified in Table 10.5.5.2.3-1 for pile groups in all soils.

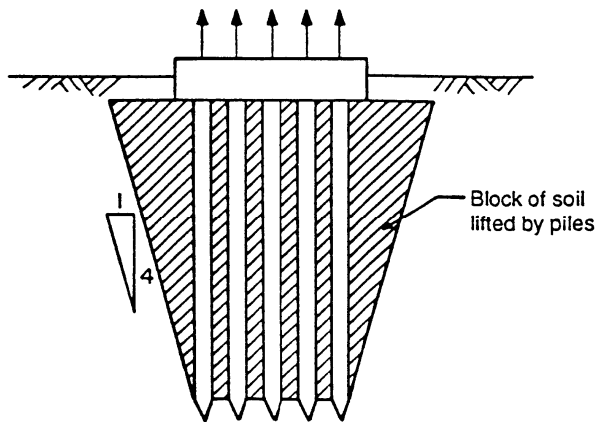

Figure 10.7.3.11-1—Uplift of Group of Closely Spaced Piles in Cohesionless Soils after Tomlinson (1987)

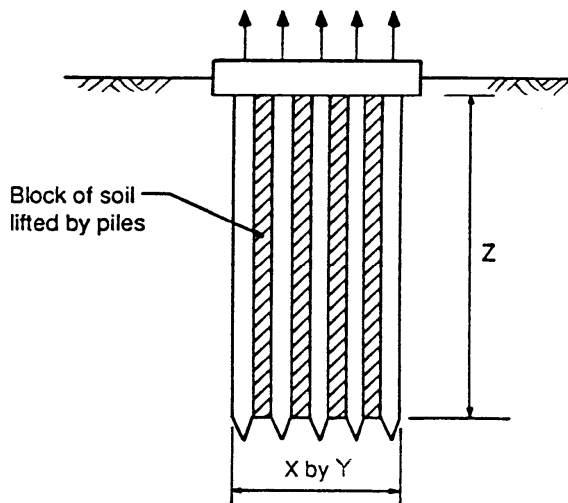

Figure 10.7.3.11-2—Uplift of Group of Piles in Cohesive Soils after Tomlinson (1987)

10.7.3.12—Nominal Lateral Resistance of Pile Foundations

The nominal resistance of pile foundations to lateral loads shall be evaluated based on both geomaterial and structural properties. The lateral soil resistance along the piles should be modeled using P - y curves developed for the soils at the site.

The applied loads shall be factored loads and they must include both lateral and axial loads. The analysis may be performed on a representative single pile with the appropriate pile top boundary condition or on the entire pile group. The P - y curves shall be modified for group effects. The P -multipliers in Table 10.7.2.4-1 should be used to modify the curves. If the pile cap will always be embedded, the P - y lateral resistance of the soil on the cap face may be included in the nominal lateral resistance.

C10.7.3.12

Pile foundations are subjected to lateral loads due to wind, traffic loads, bridge curvature, stream flow, vessel or traffic impact and earthquake. Batter piles are sometimes used but they are somewhat more expensive than vertical piles and vertical piles are more effective against dynamic loads.

Additional details regarding methods of analysis using P - y curves, both for single piles and pile groups, are provided in Article 10.7.2.4. As an alternative to P - y analysis, strain wedge theory may be used (see Article 10.7.2.4).

When this analysis is performed, the loads are factored since the strength limit state is under consideration, but the resistances as represented by the P - y curves are not factored since they already represent the ultimate condition.

The minimum penetration of the piles below ground (see Article 10.7.6) required in the contract should be established such that fixity is obtained. For this determination, the loads applied to the pile are factored as specified in Section 3, and a soil resistance factor of 1.0 shall be used as specified in Table 10.5.5.2.3-1.

If fixity cannot be obtained, additional piles should be added, larger diameter piles used if feasible to drive them to the required depth, or a wider spacing of piles in the group should be considered to provide the necessary lateral resistance. Batter piles may be added to provide the lateral resistance needed, unless downdrag is anticipated. If downdrag is anticipated, batter piles should not be used. The design procedure, if fixity cannot be obtained, should take into consideration the lack of fixity of the pile.

Lateral resistance of single piles may be determined by static load test. If a static lateral load test is to be performed, it shall follow the procedures specified in ASTM D3966.

10.7.3.13—Pile Structural Resistance

10.7.3.13.1—Steel Piles

The nominal axial compression resistance in the structural limit state for piles loaded in compression shall be as specified in Article 6.9.4.1 for noncomposite piles and Article 6.9.5.1 for composite piles. If the pile is fully embedded, λ in Eq. 6.9.5.11 shall be taken as 0.

The nominal axial resistance of horizontally unsupported noncomposite piles that extend above the ground surface in air or water shall be determined from Eqs. 6.9.4.1.1-1 or 6.9.4.1.1-2. The nominal axial resistance of horizontally unsupported composite piles that extend above the ground surface in air or water shall be determined from Eqs. 6.9.5.1-1 or 6.9.5.1-2.

The effective length of laterally unsupported piles should be determined based on the provisions in Article 10.7.3.13.4.

The resistance factors for the compression limit state are specified in Article 6.5.4.2.

10.7.3.13.2—Concrete Piles

The nominal axial compression resistance for concrete piles and prestressed concrete piles shall be as specified in Article 5.7.4.4.

The nominal axial compression resistance for concrete piles that are laterally unsupported in air or water shall be determined using the procedures given in Articles 5.7.4.3 and 4.5.3.2. The effective length of laterally unsupported piles should be determined based on the provisions in Article 10.7.3.13.4.

The resistance factor for the compression limit state for concrete piles shall be that given in Article 5.5.4.2.1 for concrete loaded in axial compression.

The strength limit state for lateral resistance is only structural (see Sections 5 and 6 for structural limit state design requirements), though the determination of pile fixity is the result of soil-structure interaction. A failure of the soil does not occur; the soil will continue to displace at constant or slightly increasing resistance. Failure occurs when the pile reaches the structural limit state, and this limit state is reached, in the general case, when the nominal combined bending and axial resistance is reached.

If the lateral resistance of the soil in front of the pile cap is included in the lateral resistance of the foundation, the effect of soil disturbance resulting from construction of the pile cap should be considered. In such cases, the passive resistance may need to be reduced to account for the effects of disturbance.

For information on analysis and interpretation of load tests, see Article 10.7.2.4.

C10.7.3.13.1

Composite members refer to steel pipe piles that are filled with concrete.

The effective length given in Article C10.7.3.13.4 is an empirical approach to determining effective length. Computer methods are now available that can determine the axial resistance of a laterally unsupported compression member using a P - Δ analysis that includes a numerical representation of the lateral soil resistance (Williams et al., 2003). These methods are preferred over the empirical approach in Article C10.7.3.13.4.

C10.7.3.13.2

Article 5.7.4 includes specified limits on longitudinal reinforcement, spirals and ties. Methods are given for determining nominal axial compression resistance but they do not include the nominal axial compression resistance of prestressed members. Article C5.7.4.1 notes that compression members are usually prestressed only where they are subjected to high levels of flexure. Therefore, a method of determining nominal axial compression resistance is not given.

Article 5.7.4.5 specifically permits an analysis based on equilibrium and strain compatibility. Methods are also available for performing a stability analysis (Williams et al., 2003).

10.7.3.13.3—Timber Piles

The nominal axial compression resistance for timber piles shall be as specified in Article 8.8.2. The methods presented there include both laterally supported and laterally unsupported members.

The effective length of laterally unsupported piles should be determined based on the provisions in Article 10.7.3.13.4.

10.7.3.13.4—Buckling and Lateral Stability

In evaluating stability, the effective length of the pile shall be equal to the laterally unsupported length, plus an embedded depth to fixity.

The potential for buckling of unsupported pile lengths and the determination of stability under lateral loading should be evaluated by methods that consider soil-structure interaction as specified in Article 10.7.3.12.

C10.7.3.13.3

Article 8.5.2.3 requires that a reduction factor for long term loads of 0.75 be multiplied times the resistance factor for Strength Load Combination IV.

C10.7.3.13.4

For preliminary design, the depth to fixity below the ground, in ft, may be taken as:

- For clays:

$$1.4 [E_p l_w / E_s]^{0.25} \quad (\text{C10.7.3.13.4-1})$$

- For sands:

$$1.8 [E_p l_w / n_h]^{0.2} \quad (\text{C10.7.3.13.4-2})$$

where:

E_p = modulus of elasticity of pile (ksi)

l_w = weak axis moment of inertia for pile (ft⁴)

E_s = soil modulus for clays = 0.465 S_u (ksi)

S_u = undrained shear strength of clays (ksf)

n_h = rate of increase of soil modulus with depth for sands as specified in Table C10.4.6.3-2 (ksi/ft)

This procedure is taken from Davisson and Robinson (1965).

In Eqs. C10.7.3.13.4-1 and C10.7.3.13.4-2, the loading condition has been assumed to be axial load only, and the piles are assumed to be fixed at their ends. Because the equations give depth to fixity from the ground line, the Engineer must determine the boundary conditions at the top of the pile to determine the total unbraced length of the pile. If other loading or pile tip conditions exist, see Davisson and Robinson (1965).

The effect of pile spacing on the soil modulus has been studied by Prakash and Sharma (1990), who found that, at pile spacings greater than 8 times the pile width, neighboring piles have no effect on the soil modulus or buckling resistance. However, at a pile spacing of three times the pile width, the effective soil modulus is reduced to 25 percent of the value applicable to a single pile. For intermediate spacings, modulus values may be estimated by interpolation.

10.7.4—Extreme Event Limit State

The provisions of Article 10.5.5.3 shall apply.

For the applicable factored loads, including those specified in Article 10.7.1.6, for each extreme event limit state, the pile foundations shall be designed to have adequate factored axial and lateral resistance. For seismic design, all soil within and above the liquefiable zone, if the soil is liquefiable, shall not be considered to contribute bearing resistance. Downdrag resulting from liquefaction

C10.7.4

See Article C10.5.5.3.3.

induced settlement shall be determined as specified in Article 3.11.8 and included in the loads applied to the foundation. Static downdrag loads should not be combined with seismic downdrag loads due to liquefaction.

The pile foundation shall also be designed to resist the horizontal force resulting from lateral spreading, if applicable, or the liquefiable soil shall be improved to prevent liquefaction and lateral spreading. For lateral soil resistance of the pile foundation, the P - y curve soil parameters should be reduced to account for liquefaction. To determine the amount of reduction, the duration of strong shaking and the ability of the soil to fully develop a liquefied condition during the period of strong shaking should be considered.

When designing for scour, the pile foundation design shall be conducted as described in Article 10.7.3.6, except that the check flood and resistance factors consistent with Article 10.5.5.3.2 shall be used.

10.7.5—Corrosion and Deterioration

The effects of corrosion and deterioration from environmental conditions shall be considered in the selection of the pile type and in the determination of the required pile cross-section.

As a minimum, the following types of deterioration shall be considered:

- Corrosion of steel pile foundations, particularly in fill soils, low pH soils, and marine environments;
- Sulfate, chloride, and acid attack of concrete pile foundations; and
- Decay of timber piles from wetting and drying cycles or from insects or marine borers.

The following soil or site conditions should be considered as indicative of a potential pile deterioration or corrosion situation:

- Resistivity less than 2,000 ohm-cm,
- pH less than 5.5,
- pH between 5.5 and 8.5 in soils with high organic content,
- Sulfate concentrations greater than 1,000 ppm,
- Landfills and cinder fills,
- Soils subject to mine or industrial drainage,

C10.7.5

Resistivity, pH, chloride content, and sulfate concentration values have been adapted from those in Fang (1991) and Tomlinson (1987).

Some states use a coal tar epoxy paint system as a protective coating with good results.

The criterion for determining the potential for deterioration varies widely. An alternative set of recommendations is given by Elias (1990).

A field electrical resistivity survey or resistivity testing and pH testing of soil and groundwater samples may be used to evaluate the corrosion potential.

The deterioration potential of steel piles may be reduced by several methods, including protective coatings, concrete encasement, cathodic protection, use of special steel alloys, or increased steel area. Protective coatings should be resistant to abrasion and have a proven service record in the corrosive environment identified. Protective coatings should extend into noncorrosive soils a few feet because the lower portion of the coating is more susceptible to abrasion loss during installation.

Concrete encasement through the corrosive zone may also be used. The concrete mix should be of low permeability and placed properly. Steel piles protected by concrete encasement should be coated with a dielectric coating near the base of the concrete jacket.

The use of special steel alloys of nickel, copper, and potassium may also be used for increased corrosion resistance in the atmosphere or splash zone of marine piling.

Sacrificial steel area may also be used for corrosion resistance. This technique over sizes the steel section so that the available section after corrosion meets structural requirements.

- Areas with a mixture of high resistivity soils and low resistivity high alkaline soils, and
- Insects (wood piles).

The following water conditions should be considered as indicative of a potential pile deterioration or corrosion situation:

- Chloride content greater than 500 ppm,
- Sulfate concentration greater than 500 ppm,
- Mine or industrial runoff,
- High organic content,
- pH less than 5.5,
- Marine borers, and
- Piles exposed to wet/dry cycles.

When chemical wastes are suspected, a full chemical analysis of soil and groundwater samples shall be considered.

10.7.6—Determination of Minimum Pile Penetration

The minimum pile penetration, if required for the particular site conditions and loading, shall be based on the maximum depth (i.e., tip elevation) needed to meet the following requirements as applicable:

- Single and pile group settlement (service limit state)
- Lateral deflection (service limit state)
- Uplift (strength limit state)
- Penetration into bearing soils needed to get below soil causing downdrag loads on the pile foundation resulting from static consolidation stresses on soft soil or downdrag loads due to liquefaction (strength and extreme event limit state, respectively)
- Penetration into bearing soils needed to get below soil subject to scour
- Penetration into bearing soils necessary to obtain fixity for resisting the applied lateral loads to the foundation (strength limit state)

Deterioration of concrete piles can be reduced by design procedures. These include use of a dense impermeable concrete, sulfate resisting Portland cement, increased steel cover, air-entrainment, reduced chloride content in the concrete mix, cathodic protection, and epoxy-coated reinforcement. Piles that are continuously submerged are less subject to deterioration. ACI 318, Section 4.5.2, provides maximum water-cement ratio requirements for special exposure conditions. ACI 318, Section 4.5.3, lists the appropriate types of cement for various types of sulfate exposure.

For prestressed concrete, ACI 318 recommends a maximum water-soluble chloride ion of 0.06 percent by weight of cement.

Cathodic protection of reinforcing and prestressing steel may be used to protect concrete from corrosion effects. This process induces electric flow from the anode to the cathode of the pile and reduces corrosion. An external DC power source may be required to drive the current. However, cathodic protection requires electrical continuity between all steel and that necessitates bonding the steel for electric connection. This bonding is expensive and usually precludes the use of cathodic protection of concrete piles.

Epoxy coating of pile reinforcement has been found in some cases to be useful in resisting corrosion. It is important to ensure that the coating is continuous and free of holidays.

More detail on design for corrosion or other forms of deterioration is contained in Hannigan et al. (2006).

C10.7.6

A minimum pile penetration should only be specified if necessary to ensure that all of the applicable limit states are met. A minimum pile penetration should not be specified solely to meet axial compression resistance, i.e., bearing, unless field verification of the pile nominal bearing resistance is not performed as described in Article 10.7.3.8.

- Axial uplift, and nominal lateral resistance to resist extreme event limit state loads

The contract documents should indicate the minimum pile penetration, if applicable, as determined above only if one or more of the requirements listed above are applicable to the pile foundation. The contract documents should also include the required nominal axial compressive resistance, R_{ndr} , as specified in Article 10.7.7 and the method by which this resistance will be verified, if applicable, such that the resistance factor(s) used for design are consistent with the construction field verification methods of nominal axial compressive pile resistance.

10.7.7—Determination of R_{ndr} Used to Establish Contract Driving Criteria for Nominal Bearing Resistance

The value of R_{ndr} used for the construction of the pile foundation to establish the driving criteria to obtain the nominal bearing resistance shall be the value that meets or exceeds the following limit states, as applicable:

- Strength limit state nominal bearing resistance specified in Article 10.7.3.8
- Strength limit state nominal bearing resistance, including downdrag specified in Article 10.7.3.7
- Strength limit state nominal bearing resistance, accounting for scour specified in Article 10.7.3.6
- Extreme event limit state nominal bearing resistance for seismic specified in Article 10.7.4
- Extreme event limit state nominal bearing resistance for scour specified in Article 10.7.4

10.7.8—Drivability Analysis

The establishment of the installation criteria for driven piles should include a drivability analysis. Except as specified herein, the drivability analysis shall be performed by the Engineer using a wave equation analysis, and the driving stresses (σ_{dr}) anywhere in the pile determined from the analysis shall be less than the following limits:

Steel Piles, compression and tension:

$$\sigma_{dr} = 0.9\phi_{da}f_y \quad (10.7.8-1)$$

where:

f_y = yield strength of the steel (ksi)

C10.7.8

Wave equation analyses should be conducted during design using a range of likely hammer/pile combinations, considering the soil and installation conditions at the foundation site. See Article 10.7.3.8.4 for additional considerations for conducting wave equation analyses. These analyses should be used to assess feasibility of the proposed foundation system and to establish installation criteria with regard to driving stresses to limit driving stresses to acceptable levels. For routine pile installation applications, e.g., smaller diameter, low nominal resistance piles, the development of installation criteria with regard to the limitation of driving stresses, e.g., minimum or maximum ram weight, hammer size, maximum acceptable driving resistance, etc., may be based on local experience,

ϕ_{da} = resistance factor as specified in Table 10.5.5.2.3-1

Concrete piles:

- In compression:

$$\sigma_{dr} = \phi_{da} 0.85 f'_c \quad (10.7.8-2)$$

- In tension, considering only the steel reinforcement:

$$\sigma_{dr} = 0.7 \phi_{da} f_y \quad (10.7.8-3)$$

where:

f'_c = compressive strength of the concrete (ksi)

f_y = yield strength of the steel reinforcement (ksi)

Prestressed concrete piles, normal environments:

- In compression:

$$\sigma_{dr} = \phi_{da} (0.85 f'_c - f_{pe}) \quad (10.7.8-4)$$

- In tension:

$$\sigma_{dr} = \phi_{da} (0.095 \sqrt{f'_c} + f_{pe}) \quad (10.7.8-5)$$

where:

f_{pe} = effective prestressing stress in concrete (ksi)

Prestressed concrete piles, severe corrosive environments:

- In tension:

$$\sigma_{dr} = \phi_{da} f_{pe} \quad (10.7.8-6)$$

Timber piles, in compression and tension:

$$\sigma_{dr} = \phi_{da} (F_{co}) \quad (10.7.8-7)$$

where:

F_{co} = base resistance of wood in compression parallel to the grain as specified in Article 8.4.1.3 (ksi)

rather than conducting a detailed wave equation analysis that is project specific. Local experience could include previous drivability analysis results and actual pile driving experience that are applicable to the project specific situation at hand. Otherwise, a project specific drivability study should be conducted.

Drivability analyses may also be conducted as part of the project construction phase. When conducted during the construction phase, the drivability analysis shall be conducted using the contractor's proposed driving system. This information should be supplied by the contractor. This drivability analysis should be used to determine if the contractor's proposed driving system is capable of driving the pile to the maximum resistance anticipated without exceeding the factored structural resistance available, i.e., σ_{dr} .

In addition to this drivability analysis, the best approach to controlling driving stresses during pile installation is to conduct dynamic testing with signal matching to verify the accuracy of the wave equation analysis results. Note that if a drivability analysis is conducted using the wave equation for acceptance of the contractor's proposed driving system, but a different method is used to develop driving resistance, i.e., blow count, criterion to obtain the specified nominal pile resistance, e.g., a driving formula, the difference in the methods regarding the predicted driving resistance should be taken into account when evaluating the contractor's driving system. For example, the wave equation analysis could indicate that the contractor's hammer can achieve the desired bearing resistance, but the driving formula could indicate the driving resistance at the required nominal bearing is too high. Such differences should be considered when setting up the driving system acceptance requirements in the contract documents, though it is preferable to be consistent in the method used for acceptance of the contractor's driving system and the one used for developing driving criteria.

The selection of a blow count limit as a definition of refusal is difficult because it can depend on the site soil profile, the pile type, hammer performance, and possibly hammer manufacturer limitations to prevent hammer damage. In general, blow counts greater than 10–15 blows per inch should be used with care, particularly with concrete or timber piles. In cases where the driving is easy until near the end of driving, a higher blow count may sometimes be satisfactory, but if a high blow count is required over a large percentage of the depth, even ten blows per inch may be too large.

This drivability analysis shall be based on the maximum driving resistance needed:

- To obtain minimum penetration requirements specified in Article 10.7.6,
- To overcome resistance of soil that cannot be counted upon to provide axial or lateral resistance throughout the design life of the structure, e.g., material subject to scour, or material subject to downdrag, and
- To obtain the required nominal bearing resistance.

10.7.9—Probe Piles

Probe piles should be driven at several locations on the site to establish order length. If dynamic measurements are not taken, these probe piles should be driven after the driving criteria have been established.

If dynamic measurements during driving are taken, both order lengths and driving criteria should be established after the probe pile(s) are driven.

10.8—DRILLED SHAFTS

10.8.1—General

10.8.1.1—Scope

The provisions of this Section shall apply to the design of drilled shafts. Throughout these provisions, the use of the term “drilled shaft” shall be interpreted to mean a shaft constructed using either drilling (open hole or with drilling slurry) or casing plus excavation equipment and technology.

These provisions shall also apply to shafts that are constructed using casing advancers that twist or rotate casings into the ground concurrent with excavation rather than drilling.

The provisions of this Section shall not be taken as applicable to drilled piles, e.g., augercast piles, installed with continuous flight augers that are concreted as the auger is being extracted.

C10.7.9

Probe piles are sometimes known as test piles or indicator piles. It is common practice to drive probe piles at the beginning of the project (particularly with concrete piles) to establish pile order lengths and/or to evaluate site variability whether or not dynamic measurements are taken.

C10.8.1.1

Drilled shafts may be an economical alternative to spread footing or pile foundations, particularly when spread footings cannot be founded on suitable soil or rock strata within a reasonable depth or when driven piles are not viable. Drilled shafts may be an economical alternative to spread footings where scour depth is large. Drilled shafts may also be considered to resist high lateral or axial loads, or when deformation tolerances are small. For example, a movable bridge is a bridge where it is desirable to keep deformations small.

Drilled shafts are classified according to their primary mechanism for deriving load resistance either as floating (friction) shafts, i.e., shafts transferring load primarily by side resistance, or end-bearing shafts, i.e., shafts transferring load primarily by tip resistance.

It is recommended that the shaft design be reviewed for constructability prior to advertising the project for bids.

10.8.1.2—Shaft Spacing, Clearance, and Embedment into Cap

If the center-to-center spacing of drilled shafts is less than 4.0 diameters, the interaction effects between adjacent shafts shall be evaluated. If the center-to-center spacing of drilled shafts is less than 6.0 diameters, the sequence of construction should be specified in the contract documents.

Shafts used in groups should be located such that the distance from the side of any shaft to the nearest edge of the cap is not less than 12.0 in. Shafts shall be embedded sufficiently into the cap to develop the required structural resistance.

10.8.1.3—Shaft Diameter and Enlarged Bases

If the shaft is to be manually inspected, the shaft diameter should not be less than 30.0 in. The diameter of columns supported by shafts should be smaller than or equal to the diameter of the drilled shaft.

In stiff cohesive soils, an enlarged base (bell, or underream) may be used at the shaft tip to increase the tip bearing area to reduce the unit end bearing pressure or to provide additional resistance to uplift loads.

Where the bottom of the drilled hole is dry, cleaned and inspected prior to concrete placement, the entire base area may be taken as effective in transferring load.

10.8.1.4—Battered Shafts

Battered shafts should be avoided. Where increased lateral resistance is needed, consideration should be given to increasing the shaft diameter or increasing the number of shafts.

C10.8.1.2

Larger spacing may be required to preserve shaft excavation stability or to prevent communication between shafts during excavation and concrete placement.

Shaft spacing may be decreased if casing construction methods are required to maintain excavation stability and to prevent interaction between adjacent shafts.

C10.8.1.3

Nominal shaft diameters used for both geotechnical and structural design of shafts should be selected based on available diameter sizes.

If the shaft and the column are the same diameter, it should be recognized that the placement tolerance of drilled shafts is such that it will likely affect the column location. The shaft and column diameter should be determined based on the shaft placement tolerance, column and shaft reinforcing clearances, and the constructability of placing the column reinforcing in the shaft. A horizontal construction joint in the shaft at the bottom of the column reinforcing will facilitate constructability. Making allowance for the tolerance where the column connects with the superstructure, which could affect column alignment, can also accommodate this shaft construction tolerance.

In drilling rock sockets, it is common to use casing through the soil zone to temporarily support the soil to prevent cave-in, allow inspection and to produce a seal along the soil-rock contact to minimize infiltration of groundwater into the socket. Depending on the method of excavation, the diameter of the rock socket may need to be sized at least 6 in. smaller than the nominal casing size to permit seating of casing and insertion of rock drilling equipment.

Where practical, consideration should be given to extension of the shaft to a greater depth to avoid the difficulty and expense of excavation for enlarged bases.

C10.8.1.4

Due to problems associated with hole stability during excavation, installation, and with removal of casing during installation of the rebar cage and concrete placement, construction of battered shafts is very difficult.

10.8.1.5—Drilled Shaft Resistance

Drilled shafts shall be designed to have adequate axial and structural resistances, tolerable settlements, and tolerable lateral displacements.

The axial resistance of drilled shafts shall be determined through a suitable combination of subsurface investigations, laboratory and/or in-situ tests, analytical methods, and load tests, with reference to the history of past performance. Consideration shall also be given to:

- The difference between the resistance of a single shaft and that of a group of shafts;
- The resistance of the underlying strata to support the load of the shaft group;
- The effects of constructing the shaft(s) on adjacent structures;
- The possibility of scour and its effect;
- The transmission of forces, such as downdrag forces, from consolidating soil;
- Minimum shaft penetration necessary to satisfy the requirements caused by uplift, scour, downdrag, settlement, liquefaction, lateral loads and seismic conditions;
- Satisfactory behavior under service loads;
- Drilled shaft nominal structural resistance; and
- Long-term durability of the shaft in service, i.e., corrosion and deterioration.

Resistance factors for shaft axial resistance for the strength limit state shall be as specified in Table 10.5.5.2.4-1.

The method of construction may affect the shaft axial and lateral resistance. The shaft design parameters shall take into account the likely construction methodologies used to install the shaft.

C10.8.1.5

The drilled shaft design process is discussed in detail in *Drilled Shafts: Construction Procedures and Design Methods* (O'Neill and Reese, 1999).

The performance of drilled shaft foundations can be greatly affected by the method of construction, particularly side resistance. The designer should consider the effects of ground and groundwater conditions on shaft construction operations and delineate, where necessary, the general method of construction to be followed to ensure the expected performance. Because shafts derive their resistance from side and tip resistance, which is a function of the condition of the materials in direct contact with the shaft, it is important that the construction procedures be consistent with the material conditions assumed in the design. Softening, loosening, or other changes in soil and rock conditions caused by the construction method could result in a reduction in shaft resistance and an increase in shaft displacement. Therefore, evaluation of the effects of the shaft construction procedure on resistance should be considered an inherent aspect of the design. Use of slurries, varying shaft diameters, and post grouting can also affect shaft resistance.

Soil parameters should be varied systematically to model the range of anticipated conditions. Both vertical and lateral resistance should be evaluated in this manner.

Procedures that may affect axial or lateral shaft resistance include, but are not limited to, the following:

- Artificial socket roughening, if included in the design nominal axial resistance assumptions.
- Removal of temporary casing where the design is dependent on concrete-to-soil adhesion.
- The use of permanent casing.
- Use of tooling that produces a uniform cross-section where the design of the shaft to resist lateral loads cannot tolerate the change in stiffness if telescoped casing is used.

It should be recognized that the design procedures provided in these Specifications assume compliance to construction specifications that will produce a high quality shaft. Performance criteria should be included in the construction specifications that require:

- Shaft bottom cleanout criteria,
- Appropriate means to prevent side wall movement or failure (caving) such as temporary casing, slurry, or a combination of the two,
- Slurry maintenance requirements including minimum slurry head requirements, slurry testing requirements, and maximum time the shaft may be left open before concrete placement.

If for some reason one or more of these performance criteria are not met, the design should be reevaluated and the shaft repaired or replaced as necessary.

10.8.1.6—Determination of Shaft Loads

10.8.1.6.1—General

The factored loads to be used in shaft foundation design shall be as specified in Section 3. Computational assumptions that shall be used in determining individual shaft loads are also specified in Section 3.

C10.8.1.6.1

The specification and determination of top of cap loads is discussed extensively in Section 3. It should be noted that Article 3.6.2.1 states that dynamic load allowance need not be applied to foundation elements that are below the ground surface. Therefore, if shafts extend above the ground surface to act as columns the dynamic load allowance should be included in evaluating the structural resistance of that part of the shaft above the ground surface. The dynamic load allowance may be ignored in evaluating the geotechnical resistance.

10.8.1.6.2—Downdrag

The provisions of Articles 10.7.1.6.2 and 3.11.8 shall apply.

C10.8.1.6.2

See commentary to Articles 10.7.1.6.2 and 3.11.8.

Downdrag loads may be estimated using the α -method, as specified in Article 10.8.3.5.1b, for calculating negative shaft resistance. As with positive shaft resistance, the top 5.0 ft and a bottom length taken as one shaft diameter should be assumed to not contribute to downdrag loads.

When using the α -method, an allowance should be made for a possible increase in the undrained shear strength as consolidation occurs. Downdrag loads may also come from cohesionless soils above settling cohesive soils, requiring granular soil friction methods be used in such zones to estimate downdrag loads.

10.8.1.6.3—Uplift

The provisions in Article 10.7.1.6.3 shall apply.

C10.8.1.6.3

See commentary to Article C10.7.1.6.3.

10.8.2—Service Limit State Design

10.8.2.1—Tolerable Movements

The requirements of Article 10.5.2.1 shall apply.

C10.8.2.1

See commentary to Article 10.5.2.1.

10.8.2.2—Settlement

10.8.2.2.1—General

The settlement of a drilled shaft foundation involving either single-drilled shafts or groups of drilled shafts shall not exceed the movement criteria selected in accordance with Article 10.5.2.1.

*10.8.2.2.2—Settlement of Single-Drilled Shaft**C10.8.2.2.2*

The settlement of single-drilled shafts shall be estimated in consideration of:

- Short-term settlement,
- Consolidation settlement if constructed in cohesive soils, and
- Axial compression of the shaft.

The normalized load-settlement curves shown in Figures 10.8.2.2.2-1 through 10.8.2.2.2-4 should be used to limit the nominal shaft axial resistance computed as specified for the strength limit state in Article 10.8.3 for service limit state tolerable movements. Consistent values of normalized settlement shall be used for limiting the base and side resistance when using these Figures. Long-term settlement should be computed according to Article 10.7.2 using the equivalent footing method and added to the short-term settlements estimated using Figures 10.8.2.2.2-1 through 10.8.2.2.2-4.

Other methods for evaluating shaft settlements that may be used are found in O'Neill and Reese (1999).

O'Neill and Reese (1999) have summarized load-settlement data for drilled shafts in dimensionless form, as shown in Figures 10.8.2.2.2-1 through 10.8.2.2.2-4. These curves do not include consideration of long-term consolidation settlement for shafts in cohesive soils. Figures 10.8.2.2.2-1 and 10.8.2.2.2-2 show the load-settlement curves in side resistance and in end bearing for shafts in cohesive soils. Figures 10.8.2.2.2-3 and 10.8.2.2.2-4 are similar curves for shafts in cohesionless soils. These curves should be used for estimating short-term settlements of drilled shafts.

The designer should exercise judgment relative to whether the trend line, one of the limits, or some relation in between should be used from Figures 10.8.2.2.2-1 through 10.8.2.2.2-4.

The values of the load-settlement curves in side resistance were obtained at different depths, taking into account elastic shortening of the shaft. Although elastic shortening may be small in relatively short shafts, it may be substantial in longer shafts. The amount of elastic shortening in drilled shafts varies with depth. O'Neill and Reese (1999) have described an approximate procedure for estimating the elastic shortening of long-drilled shafts.

Settlements induced by loads in end bearing are different for shafts in cohesionless soils and in cohesive soils. Although drilled shafts in cohesive soils typically have a well-defined break in a load-displacement curve, shafts in cohesionless soils often have no well-defined failure at any displacement. The resistance of drilled shafts in cohesionless soils continues to increase as the settlement increases beyond five percent of the base diameter. The shaft end bearing R_p is typically fully mobilized at displacements of two to five percent of the base diameter for shafts in cohesive soils. The unit end bearing resistance for the strength limit state (see Article 10.8.3.3) is defined as the bearing pressure required to cause vertical deformation equal to five percent of the shaft diameter, even though this does not correspond to complete failure of the soil beneath the base of the shaft.

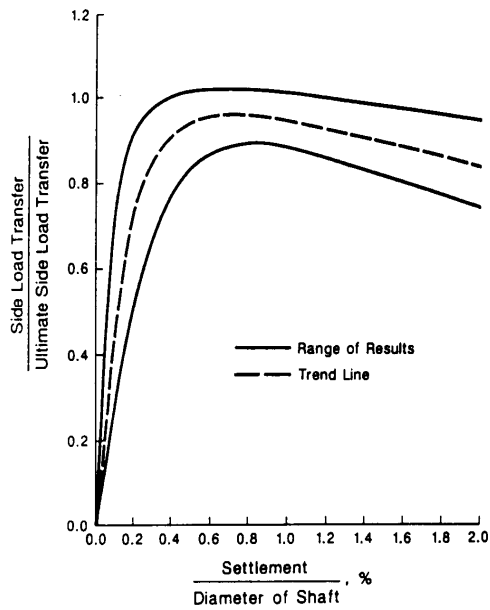

The curves in Figures 10.8.2.2.2-1 and 10.8.2.2.2-3 also show the settlements at which the side resistance is mobilized. The shaft skin friction R_s is typically fully mobilized at displacements of 0.2 percent to 0.8 percent of the shaft diameter for shafts in cohesive soils. For shafts in cohesionless soils, this value is 0.1 percent to 1.0 percent.

Figure 10.8.2.2.2-1 Normalized Load Transfer in Side Resistance versus Settlement in Cohesive Soils (from O'Neill and Reese, 1999)

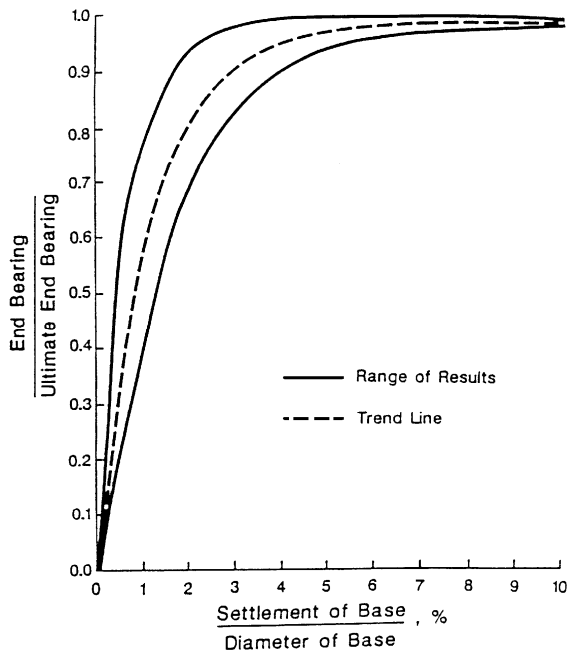

Figure 10.8.2.2.2-2—Normalized Load Transfer in End Bearing versus Settlement in Cohesive Soils (from O'Neill and Reese, 1999)

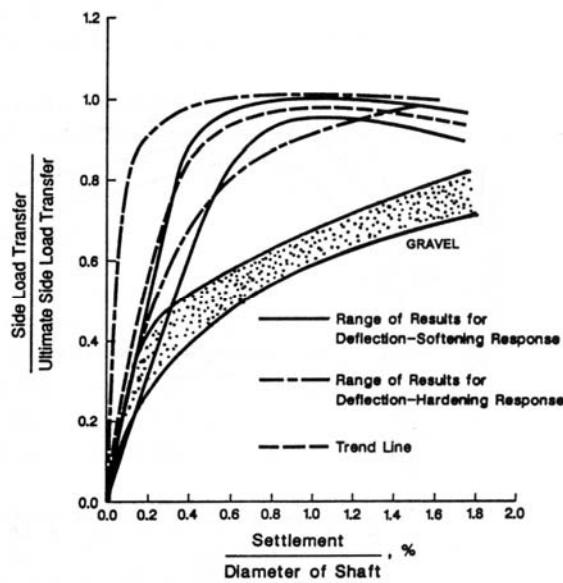

Figure 10.8.2.2.2-3—Normalized Load Transfer in Side Resistance versus Settlement in Cohesionless Soils (from O'Neill and Reese, 1999)

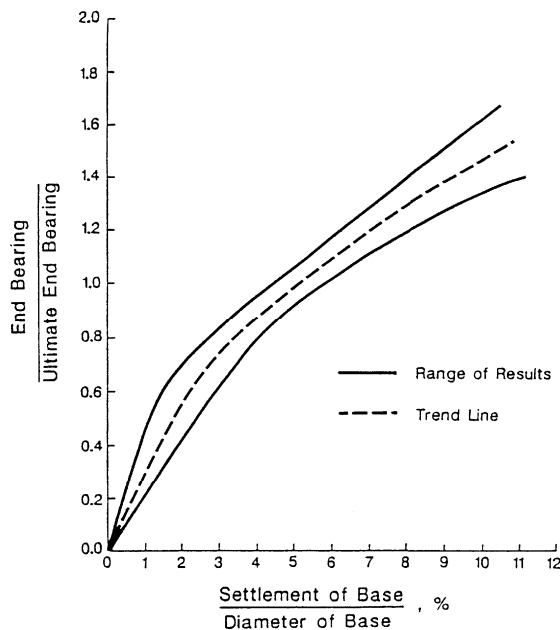

Figure 10.8.2.2.2-4—Normalized Load Transfer in End Bearing versus Settlement in Cohesionless Soils (from O'Neill and Reese, 1999)

10.8.2.2.3—Intermediate Geo Materials (IGMs)

For detailed settlement estimation of shafts in IGMs, the procedures provided by O'Neill and Reese (1999) should be used.

The deflection-softening response typically applies to cemented or partially cemented soils, or other soils that exhibit brittle behavior, having low residual shear strengths at larger deformations. Note that the trend line for sands is a reasonable approximation for either the deflection-softening or deflection-hardening response.

C10.8.2.2.3

IGMs are defined by O'Neill and Reese (1999) as follows:

- *Cohesive IGM*—clay shales or mudstones with an S_u of 5 to 50 ksf, and
- *Cohesionless*—granular tills or granular residual soils with N_{160} greater than 50 blows/ft.

10.8.2.2.4—Group Settlement

The provisions of Article 10.7.2.3 shall apply. Shaft group effect shall be considered for groups of 2 shafts or more.

C10.8.2.2.4

See commentary to Article 10.7.2.3.

O'Neill and Reese (1999) summarize various studies on the effects of shaft group behavior. These studies were for groups that consisted of 1×2 to 3×3 shafts. These studies suggest that group effects are relatively unimportant for shaft center-to-center spacing of $5D$ or greater.

10.8.2.3—Horizontal Movement of Shafts and Shaft Groups

The provisions of Articles 10.5.2.1 and 10.7.2.4 shall apply.

C10.8.2.3

See commentary to Articles 10.5.2.1 and 10.7.2.4.

10.8.2.4—Settlement Due to Downdrag

The provisions of Article 10.7.2.5 shall apply.

C10.8.2.4

See commentary to Article 10.7.2.5.

10.8.2.5—Lateral Squeeze

The provisions of Article 10.7.2.6 shall apply.

C10.8.2.5

See commentary to Article 10.7.2.6.

10.8.3—Strength Limit State Design**10.8.3.1—General**

The nominal shaft resistances that shall be considered at the strength limit state include:

- Axial compression resistance,
- Axial uplift resistance,
- Punching of shafts through strong soil into a weaker layer,
- Lateral geotechnical resistance of soil and rock stratum,
- Resistance when scour occurs,
- Axial resistance when downdrag occurs, and
- Structural resistance of shafts.

10.8.3.2—Groundwater Table and Buoyancy

The provisions of Article 10.7.3.5 shall apply.

C10.8.3.2

See commentary to Article 10.7.3.5.

10.8.3.3—Scour

The provisions of Article 10.7.3.6 shall apply.

C10.8.3.3

See commentary to Article 10.7.3.6.

10.8.3.4—Downdrag

The provisions of Article 10.7.3.7 shall apply.

C10.8.3.4

See commentary to Article 10.7.3.7.

10.8.3.5—Nominal Axial Compression Resistance of Single Drilled Shafts

The factored resistance of drilled shafts, R_R , shall be taken as:

$$R_R = \phi R_n = \phi_{qp} R_p + \phi_{qs} R_s \quad (10.8.3.5-1)$$

in which:

$$R_p = q_p A_p \quad (10.8.3.5-2)$$

$$R_s = q_s A_s \quad (10.8.3.5-3)$$

where:

R_p = nominal shaft tip resistance (kips)

R_s = nominal shaft side resistance (kips)

ϕ_{qp} = resistance factor for tip resistance specified in Table 10.5.5.2.4-1

ϕ_{qs} = resistance factor for shaft side resistance specified in Table 10.5.5.2.4-1

q_p = unit tip resistance (ksf)

q_s = unit side resistance (ksf)

A_p = area of shaft tip (ft²)

A_s = area of shaft side surface (ft²)

The methods for estimating drilled shaft resistance provided in this Article should be used. Shaft strength limit state resistance methods not specifically addressed in this Article for which adequate successful regional or national experience is available may be used, provided adequate information and experience is also available to develop appropriate resistance factors.

10.8.3.5.1—Estimation of Drilled Shaft Resistance in Cohesive Soils

10.8.3.5.1a—General

Drilled shafts in cohesive soils should be designed by total and effective stress methods for undrained and drained loading conditions, respectively.

C10.8.3.5

The nominal axial compression resistance of a shaft is derived from the tip resistance and/or shaft side resistance, i.e., skin friction. Both the tip and shaft resistances develop in response to foundation displacement. The maximum values of each are unlikely to occur at the same displacement, as described in Article 10.8.2.2.2.

For consistency in the interpretation of both static load tests (Article 10.8.3.5.6) and the normalized curves of Article 10.8.2.2.2, it is customary to establish the failure criterion at the strength limit state at a gross deflection equal to five percent of the base diameter for drilled shafts.

O'Neill and Reese (1999) identify several methods for estimating the resistance of drilled shafts in cohesive and granular soils, intermediate geomaterials, and rock. The most commonly used methods are provided in this Article. Methods other than the ones provided in detail in this Article may be used provided that adequate local or national experience with the specific method is available to have confidence that the method can be used successfully and that appropriate resistance factors can be determined. At present, it must be recognized that these resistance factors have been developed using a combination of calibration by fitting to previous allowable stress design (ASD) practice and reliability theory (see Allen, 2005, for additional details on the development of resistance factors for drilled shafts). Such methods may be used as an alternative to the specific methodology provided in this Article, provided that:

- The method selected consistently has been used with success on a regional or national basis.
- Significant experience is available to demonstrate that success.
- As a minimum, calibration by fitting to allowable stress design is conducted to determine the appropriate resistance factor, if inadequate measured data are available to assess the alternative method using reliability theory. A similar approach as described by Allen (2005) should be used to select the resistance factor for the alternative method.

10.8.3.5.1b—Side Resistance

The nominal unit side resistance, q_s , in ksf, for shafts in cohesive soil loaded under undrained loading conditions by the α -Method shall be taken as:

$$q_s = \alpha S_u \quad (10.8.3.5.1b-1)$$

in which:

$$\alpha = 0.55 \text{ for } \frac{S_u}{p_a} \leq 1.5 \quad (10.8.3.5.1b-2)$$

$$\alpha = 0.55 - 0.1(S_u/p_a - 1.5) \text{ for } 1.5 \leq S_u/p_a \leq 2.5 \quad (10.8.3.5.1b-3)$$

where:

S_u = undrained shear strength (ksf)

α = adhesion factor (dim)

p_a = atmospheric pressure (= 2.12 ksf)

The following portions of a drilled shaft, illustrated in Figure 10.8.3.5.1b-1, should not be taken to contribute to the development of resistance through skin friction:

- At least the top 5.0 ft of any shaft;
- For straight shafts, a bottom length of the shaft taken as the shaft diameter;
- Periphery of belled ends, if used; and
- Distance above a belled end taken as equal to the shaft diameter.

When permanent casing is used, the side resistance shall be adjusted with consideration to the type and length of casing to be used, and how it is installed.

Values of α for contributing portions of shafts excavated dry in open or cased holes should be as specified in Eqs. 10.8.3.5.1b-2 and 10.8.3.5.1b-3.

C10.8.3.5.1b

The α -method is based on total stress. For effective stress methods for shafts in clay, see O'Neill and Reese (1999).

The adhesion factor is an empirical factor used to correlate the results of full-scale load tests with the material property or characteristic of the cohesive soil. The adhesion factor is usually related to S_u and is derived from the results of full-scale pile and drilled shaft load tests. Use of this approach presumes that the measured value of S_u is correct and that all shaft behavior resulting from construction and loading can be lumped into a single parameter. Neither presumption is strictly correct, but the approach is used due to its simplicity.

Steel casing will generally reduce the side resistance of a shaft. No specific data is available regarding the reduction in skin friction resulting from the use of permanent casing relative to concrete placed directly against the soil. Side resistance reduction factors for driven steel piles relative to concrete piles can vary from 50 to 75 percent, depending on whether the steel is clean or rusty, respectively (Potyondy, 1961). Greater reduction in the side resistance may be needed if oversized cutting shoes or splicing rings are used.

If open-ended pipe piles are driven full depth with an impact hammer before soil inside the pile is removed, and left as a permanent casing, driven pile static analysis methods may be used to estimate the side resistance as described in Article 10.7.3.8.6.

The upper 5.0 ft of the shaft is ignored in estimating R_n , to account for the effects of seasonal moisture changes, disturbance during construction, cyclic lateral loading, and low lateral stresses from freshly placed concrete. The lower 1.0-diameter length above the shaft tip or top of enlarged base is ignored due to the development of tensile cracks in the soil near these regions of the shaft and a corresponding reduction in lateral stress and side resistance.

Bells or underreams constructed in stiff fissured clay often settle sufficiently to result in the formation of a gap above the bell that will eventually be filled by slumping soil. Slumping will tend to loosen the soil immediately above the bell and decrease the side resistance along the lower portion of the shaft.

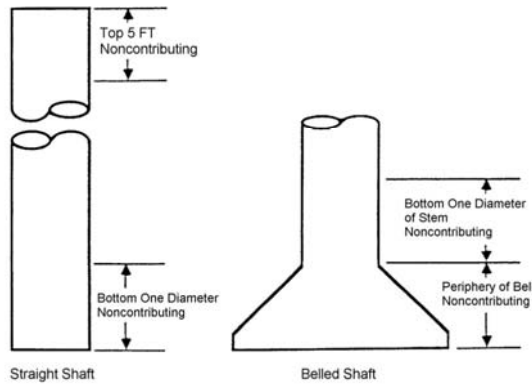

Figure 10.8.3.5.1b-1—Explanation of Portions of Drilled Shafts Not Considered in Computing Side Resistance (O’Neill and Reese, 1999)

The value of α is often considered to vary as a function of S_u . Values of α for drilled shafts are recommended as shown in Eqs. 10.8.3.5.1b-2 and 10.8.3.5.1b-3, based on the results of back-analyzed, full-scale load tests. This recommendation is based on eliminating the upper 5.0 ft and lower 1.0 diameter of the shaft length during back-analysis of load test results. The load tests were conducted in insensitive cohesive soils. Therefore, if shafts are constructed in sensitive clays, values of α may be different than those obtained from Eqs. 10.8.3.5.1b-2 and 10.8.3.5.1b-3. Other values of α may be used if based on the results of load tests.

The depth of 5.0 ft at the top of the shaft may need to be increased if the drilled shaft is installed in expansive clay, if scour deeper than 5.0 ft is anticipated, if there is substantial groundline deflection from lateral loading, or if there are other long-term loads or construction factors that could affect shaft resistance.

A reduction in the effective length of the shaft contributing to side resistance has been attributed to horizontal stress relief in the region of the shaft tip, arising from development of outward radial stresses at the toe during mobilization of tip resistance. The influence of this effect may extend for a distance of $1B$ above the tip (O’Neill and Reese, 1999). The effectiveness of enlarged bases is limited when L/D is greater than 25.0 due to the lack of load transfer to the tip of the shaft.

The values of α obtained from Eqs. 10.8.3.5.1b-2 and 10.8.3.5.1b-3 are considered applicable for both compression and uplift loading.

10.8.3.5.1c—Tip Resistance

For axially loaded shafts in cohesive soil, the nominal unit tip resistance, q_p , by the total stress method as provided in O’Neill and Reese (1999) shall be taken as:

$$q_p = N_c S_u \leq 80.0 \quad (10.8.3.5.1c-1)$$

in which:

$$N_c = 6 \left[1 + 0.2 \left(\frac{Z}{D} \right) \right] \leq 9 \quad (10.8.3.5.1c-2)$$

where:

D = diameter of drilled shaft (ft)

Z = penetration of shaft (ft)

S_u = undrained shear strength (ksf)

C10.8.3.5.1c

These equations are for total stress analysis. For effective stress methods for shafts in clay, see O’Neill and Reese (1999).

The limiting value of 80.0 ksf for q_p is not a theoretical limit but a limit based on the largest measured values. A higher limiting value may be used if based on the results of a load test, or previous successful experience in similar soils.

The value of S_u should be determined from the results of in-situ and/or laboratory testing of undisturbed samples obtained within a depth of 2.0 diameters below the tip of the shaft. If the soil within 2.0 diameters of the tip has $S_u < 0.50$ ksf, the value of N_c should be multiplied by 0.67.

10.8.3.5.2—Estimation of Drilled Shaft Resistance in Cohesionless Soils

10.8.3.5.2a—General

Shafts in cohesionless soils should be designed by effective stress methods for drained loading conditions or by empirical methods based on in-situ test results.

C10.8.3.5.2a

The factored resistance should be determined in consideration of available experience with similar conditions.

Although many field load tests have been performed on drilled shafts in clays, very few have been performed on drilled shafts in sands. The shear strength of cohesionless soils can be characterized by an angle of internal friction, ϕ_f , or empirically related to its *SPT* blow count, N . Methods of estimating shaft resistance and end bearing are presented below. Judgment and experience should always be considered.

10.8.3.5.2b—Side Resistance

The nominal axial resistance of drilled shafts in cohesionless soils by the β -method shall be taken as:

$$q_s = \beta \sigma'_v \leq 4.0 \text{ for } 0.25 \leq \beta \leq 1.2 \quad (10.8.3.5.2b-1)$$

in which, for sandy soils:

- for $N_{60} \geq 15$:

$$\beta = 1.5 - 0.135\sqrt{z} \quad (10.8.3.5.2b-2)$$

- for $N_{60} < 15$:

$$\beta = \frac{N_{60}}{15} (1.5 - 0.135\sqrt{z}) \quad (10.8.3.5.2b-3)$$

where:

σ'_v = vertical effective stress at soil layer mid-depth (ksf)

β = load transfer coefficient (dim)

z = depth below ground, at soil layer mid-depth (ft)

N_{60} = average *SPT* blow count (corrected only for hammer efficiency) in the design zone under consideration (blows/ft)

Higher values may be used if verified by load tests.

C10.8.3.5.2b

O'Neill and Reese (1999) provide additional discussion of computation of shaft side resistance and recommend allowing β to increase to 1.8 in gravels and gravelly sands, however, they recommend limiting the unit side resistance to 4.0 ksf in all soils.

O'Neill and Reese (1999) proposed a method for uncemented soils that uses a different approach in that the shaft resistance is independent of the soil friction angle or the *SPT* blow count. According to their findings, the friction angle approaches a common value due to high shearing strains in the sand caused by stress relief during drilling.

For gravelly sands and gravels, Eq. 10.8.3.5.2b-4 should be used for computing β where $N_{60} \geq 15$. If $N_{60} < 15$, Eq. 10.8.3.5.2b-3 should be used.

$$\beta = 2.0 - 0.06(z)^{0.75} \quad (10.8.3.5.2b-4)$$

When permanent casing is used, the side resistance shall be adjusted with consideration to the type and length of casing to be used, and how it is installed.

The detailed development of Eq. 10.8.3.5.2b-4 is provided in O'Neill and Reese (1999).

Steel casing will generally reduce the side resistance of a shaft. No specific data is available regarding the reduction in skin friction resulting from the use of permanent casing relative to concrete placed directly against the soil. Side resistance reduction factors for driven steel piles relative to concrete piles can vary from 50 to 75 percent, depending on whether the steel is clean or rusty, respectively (Potyondy, 1961). Casing reduction factors of 0.6 to 0.75 are commonly used. Greater reduction in the side resistance may be needed if oversized cutting shoes or splicing rings are used.

If open-ended pipe piles are driven full depth with an impact hammer before soil inside the pile is removed, and left as a permanent casing, driven pile static analysis methods may be used to estimate the side resistance as described in Article 10.7.3.8.6.

10.8.3.5.2c—Tip Resistance

The nominal tip resistance, q_p , in ksf, for drilled shafts in cohesionless soils by the O'Neill and Reese (1999) method shall be taken as:

$$\text{for } N_{60} \leq 50, q_p = 1.2N_{60} \quad (10.8.3.5.2c-1)$$

where:

N_{60} = average *SPT* blow count (corrected only for hammer efficiency) in the design zone under consideration (blows/ft)

The value of q_p in Eq. 10.8.3.5.2c-1 should be limited to 60 ksf, unless greater values can be justified through load test data.

Cohesionless soils with *SPT*- N_{60} blow counts greater than 50 shall be treated as intermediate geomaterial (IGM) and the tip resistance, in ksf, taken as:

$$q_p = 0.59 \left[N_{60} \left(\frac{p_a}{\sigma'_v} \right) \right]^{0.8} \sigma'_v \quad (10.8.3.5.2c-2)$$

where:

p_a = atmospheric pressure (= 2.12 ksf)

σ'_v = vertical effective stress at the tip elevation of the shaft (ksf)

C10.8.3.5.2c

O'Neill and Reese (1999) provide additional discussion regarding the computation of nominal tip resistance.

See O'Neill and Reese (1999) for background on IGMs.

N_{60} should be limited to 100 in Eq. 10.8.3.5.2c-2 if higher values are measured.

10.8.3.5.3—Shafts in Strong Soil Overlying Weaker Compressible Soil

Where a shaft is tipped in a strong soil layer overlying a weaker layer, the base resistance shall be reduced if the shaft base is within a distance of $1.5B$ of the top of the weaker layer. A weighted average should be used that varies linearly from the full base resistance in the overlying strong layer at a distance of $1.5B$ above the top of the weaker layer to the base resistance of the weaker layer at the top of the weaker layer.

10.8.3.5.4—Estimation of Drilled Shaft Resistance in Rock

10.8.3.5.4a—General

Drilled shafts in rock subject to compressive loading shall be designed to support factored loads in:

- Side-wall shear comprising skin friction on the wall of the rock socket; or
- End bearing on the material below the tip of the drilled shaft; or
- A combination of both.

The difference in the deformation required to mobilize skin friction in soil and rock versus what is required to mobilize end bearing shall be considered when estimating axial compressive resistance of shafts embedded in rock. Where end bearing in rock is used as part of the axial compressive resistance in the design, the contribution of skin friction in the rock shall be reduced to account for the loss of skin friction that occurs once the shear deformation along the shaft sides is greater than the peak rock shear deformation, i.e., once the rock shear strength begins to drop to a residual value.

C10.8.3.5.3

The distance of $1.5B$ represents the zone of influence for general bearing capacity failure based on bearing capacity theory for deep foundations.

C10.8.3.5.4a

Methods presented in this Article to calculate drilled shaft axial resistance require an estimate of the uniaxial compressive strength of rock core. Unless the rock is massive, the strength of the rock mass is most frequently controlled by the discontinuities, including orientation, length, and roughness, and the behavior of the material that may be present within the discontinuity, e.g., gouge or infilling. The methods presented are semi-empirical and are based on load test data and site-specific correlations between measured resistance and rock core strength.

Design based on side-wall shear alone should be considered for cases in which the base of the drilled hole cannot be cleaned and inspected or where it is determined that large movements of the shaft would be required to mobilize resistance in end bearing.

Design based on end-bearing alone should be considered where sound bedrock underlies low strength overburden materials, including highly weathered rock. In these cases, however, it may still be necessary to socket the shaft into rock to provide lateral stability.

Where the shaft is drilled some depth into sound rock, a combination of sidewall shear and end bearing can be assumed (*Kulhawy and Goodman, 1980*).

If the rock is degradable, use of special construction procedures, larger socket dimensions, or reduced socket resistance should be considered.

For drilled shafts installed in karstic formations, exploratory borings should be advanced at each drilled shaft location to identify potential cavities. Layers of compressible weak rock along the length of a rock socket and within approximately three socket diameters or more below the base of a drilled shaft may reduce the resistance of the shaft.

For rock that is stronger than concrete, the concrete shear strength will control the available side friction, and the strong rock will have a higher stiffness, allowing significant end bearing to be mobilized before the side wall shear strength reaches its peak value. Note that concrete typically reaches its peak shear strength at about 250 to 400 microstrain (for a 10-ft long rock socket, this is approximately 0.5 in. of deformation at the top of the rock socket). If strains or deformations greater than the value at the peak shear stress are anticipated to mobilize the desired end bearing in the rock, a residual value for the skin friction can still be used. Article 10.8.3.5.4d provides procedures for computing a residual value of the skin friction based on the properties of the rock and shaft.

10.8.3.5.4b—Side Resistance

For drilled shafts socketed into rock, shaft resistance, in ksf, may be taken as (Horvath and Kenney, 1979):

$$q_s = 0.65\alpha_E p_a (q_u/p_a)^{0.5} < 7.8 p_a (f'_c/p_a)^{0.5} \quad (10.8.3.5.4b-1)$$

where:

- q_u = uniaxial compressive strength of rock (ksf)
 p_a = atmospheric pressure (= 2.12 ksf)
 α_E = reduction factor to account for jointing in rock as provided in Table 10.8.3.5.4b-1
 f'_c = concrete compressive strength (ksi)

Table 10.8.3.5.4b-1—Estimation of α_E (O'Neill and Reese, 1999)

E_m/E_i	α_E
1.0	1.0
0.5	0.8
0.3	0.7
0.1	0.55
0.05	0.45

C10.8.3.5.4b

Eq. 10.8.3.5.4b-1 applies to the case where the side of the rock socket is considered to be smooth or where the rock is drilled using a drilling slurry. Significant additional shaft resistance may be achieved if the borehole is specified to be artificially roughened by grooving. Methods to account for increased shaft resistance due to borehole roughness are provided in Section 11 of O'Neill and Reese (1999).

Eq. 10.8.3.5.4b-1 should only be used for intact rock. When the rock is highly jointed, the calculated q_s should be reduced to arrive at a final value for design. The procedure is as follows:

- Step 1. Evaluate the ratio of rock mass modulus to intact rock modulus, i.e., E_m/E_i , using Table C10.4.6.5-1.
- Step 2. Evaluate the reduction factor, α_E , using Table 10.8.3.5.4b-1.
- Step 3. Calculate q_s according to Eq. 10.8.3.5.4b-1.

10.8.3.5.4c—Tip Resistance

End-bearing for drilled shafts in rock may be taken as follows:

- If the rock below the base of the drilled shaft to a depth of $2.0B$ is either intact or tightly jointed, i.e., no compressible material or gouge-filled seams, and the depth of the socket is greater than $1.5B$ (O'Neill and Reese, 1999):

$$q_p = 2.5q_u \quad (10.8.3.5.4c-1)$$

- If the rock below the base of the shaft to a depth of $2.0B$ is jointed, the joints have random orientation, and the condition of the joints can be evaluated as:

$$q_p = \left[\sqrt{s} + \sqrt{(m \sqrt{s} + s)} \right] q_u \quad (10.8.3.5.4c-2)$$

where:

s, m = fractured rock mass parameters and are specified in Table 10.4.6.4-4

q_u = unconfined compressive strength of rock (ksf)

10.8.3.5.4d—Combined Side and Tip Resistance

Design methods that consider the difference in shaft movement required to mobilize skin friction in rock versus what is required to mobilize end bearing, such as the methodology provided by O'Neill and Reese (1999), shall be used to estimate axial compressive resistance of shafts embedded in rock.

C10.8.3.5.4c

If end bearing in the rock is to be relied upon, and wet construction methods are used, bottom clean-out procedures such as airlifts should be specified to ensure removal of loose material before concrete placement.

The use of Eq. 10.8.3.5.4c-1 also requires that there are no solution cavities or voids below the base of the drilled shaft.

For further information see O'Neill and Reese (1999).

Eq. 10.8.3.5.4c-2 is a lower bound solution for bearing resistance for a drilled shaft bearing on or socketed in a fractured rock mass. This method is appropriate for rock with joints that are not necessarily oriented preferentially and the joints may be open, closed, or filled with weathered material. Load testing will likely indicate higher tip resistance than that calculated using Eq. 10.8.3.5.4c-2. Resistance factors for this method have not been developed and must therefore be estimated by the designer.

C10.8.3.5.4d

Typically, the axial compression load on a shaft socketed into rock is carried solely in shaft side resistance until a total shaft movement on the order of 0.4 in. occurs.

Designs which consider combined effects of side friction and end-bearing of a drilled shaft in rock require that side friction resistance and end bearing resistance be evaluated at a common value of axial displacement, since maximum values of side friction and end-bearing are not generally mobilized at the same displacement.

Where combined side friction and end-bearing in rock is considered, the designer needs to evaluate whether a significant reduction in side resistance will occur after the peak side resistance is mobilized. As indicated in Figure C10.8.3.5.4d-1, when the rock is brittle in shear, much shaft resistance will be lost as vertical movement increases to the value required to develop the full value of q_p . If the rock is ductile in shear, i.e., deflection softening does not occur, then the side resistance and end-bearing resistance can be added together directly. If the rock is brittle, however, adding them directly may be unconservative. Load testing or laboratory shear strength testing, e.g., direct shear testing, may be used to evaluate whether the rock is brittle or ductile in shear.

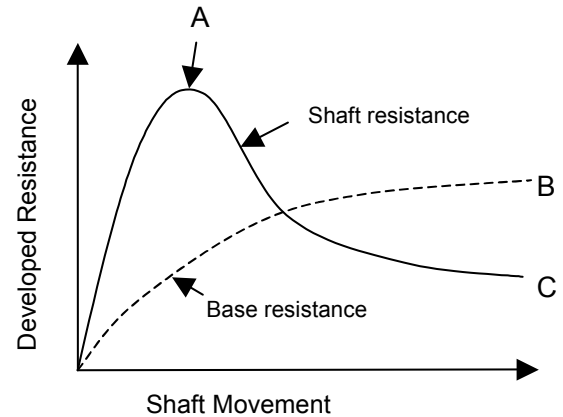

Figure C10.8.3.5.4d-1—Deflection Softening Behavior of Drilled Shafts under Compression Loading (after O’Neill and Reese, 1999).

The method used to evaluate combined side friction and end-bearing at the strength limit state requires the construction of a load-vertical deformation curve. To accomplish this, calculate the total load acting at the head of the drilled shaft, Q_{T1} , and vertical movement, w_{T1} , when the nominal shaft side resistance (Point A on Figure C10.8.3.5.4d-1) is mobilized. At this point, some end bearing is also mobilized. For detailed computational procedures for estimating shaft resistance in rock, considering the combination of side and tip resistance, see O’Neill and Reese (1999).

10.8.3.5.5—Estimation of Drilled Shaft Resistance in Intermediate Geo Materials (IGMs)

For detailed base and side resistance estimation procedures for shafts in IGMs, the procedures provided by O’Neill and Reese (1999) should be used.

10.8.3.5.6—Shaft Load Test

When used, load tests shall be conducted in representative soil conditions using shafts constructed in a manner and of dimensions and materials similar to those planned for the production shafts. The load test shall follow the procedures specified in ASTM D1143. The loading procedure should follow the Quick Load Test Method, unless detailed longer-term load-settlement data is needed, in which case the standard loading procedure should be used.

The nominal resistance shall be determined according to the failure definition of either:

- “Plunging” of the drilled shaft, or
- A gross settlement or uplift of five percent of the diameter of the shaft if plunging does not occur.

C10.8.3.5.5

See Article 10.8.2.2.3 for a definition of an IGM.

For convenience, since a common situation is to tip the shaft in a cohesionless IGM, the equation for tip resistance in a cohesionless IGM is provided in Article C10.8.3.5.2c.

C10.8.3.5.6

For a larger project where many shafts are to be used, it may be cost-effective to perform a full-scale load test on a drilled shaft during the design phase of a project to confirm response to load.

Load tests should be conducted following prescribed written procedures that have been developed from accepted standards and modified, as appropriate, for the conditions at the site. The Quick Test Procedure is desirable because it avoids problems that frequently arise when performing a static test that cannot be started and completed within an eight-hour period. Tests that extend over a longer period are difficult to perform due to the limited number of experienced personnel that are usually available. The Quick Test has proven to be easily

The resistance factors for axial compressive resistance or axial uplift resistance shall be taken as specified in Table 10.5.5.2.4-1.

Regarding the use of shaft load test data to determine shaft resistance, the load test results should be applied to production shafts that are not load tested by matching the static resistance prediction to the load test results. The calibrated static analysis method should then be applied to adjacent locations within the site to determine the shaft tip elevation required, in consideration of variations in the geologic stratigraphy and design properties at each production shaft location. The definition of a site and number of load tests required to account for site variability shall be as specified in Article 10.5.5.2.3.

performed in the field, and the results usually are satisfactory. However, if the formation in which the shaft is installed may be subject to significant creep settlement, alternative procedures provided in ASTM D1143 should be considered.

Load tests are conducted on full-scale drilled shaft foundations to provide data regarding nominal axial resistance, load-displacement response, and shaft performance under the design loads, and to permit assessment of the validity of the design assumptions for the soil conditions at the test shaft(s).

Tests can be conducted for compression, uplift, lateral loading, or for combinations of loading. Full-scale load tests in the field provide data that include the effects of soil, rock, and groundwater conditions at the site; the dimensions of the shaft; and the procedures used to construct the shaft.

The results of full-scale load tests can differ even for apparently similar ground conditions. Therefore, care should be exercised in generalizing and extrapolating the test results to other locations.

For large diameter shafts, where conventional reaction frames become unmanageably large, load testing using Osterberg load cells may be considered. Additional discussion regarding load tests is provided in O'Neill and Reese (1999). Alternatively, smaller diameter shafts may be load tested to represent the larger diameter shafts (but no less than one-half the full scale production shaft diameter), provided that appropriate measures are taken to account for potential scale effects when extrapolating the results to the full scale production shafts.

Plunging occurs when a steady increase in movement results from incrementally small increases in load, e.g., 2.0 kips.

10.8.3.6—Shaft Group Resistance

10.8.3.6.1—General

Reduction in resistance from group effects shall be evaluated.

C10.8.3.6.1

In addition to the overlap effects discussed below, drilling of a hole for a shaft less than three shaft diameters from an existing shaft reduces the effective stresses against both the side and base of the existing shaft. As a result, the capacities of individual drilled shafts within a group tend to be less than the corresponding capacities of isolated shafts.

If casing is advanced in front of the excavation heading, this reduction need not be made.

10.8.3.6.2—Cohesive Soil

C10.8.3.6.2

The provisions of Article 10.7.3.9 shall apply.

The resistance factor for the group resistance of an equivalent pier or block failure provided in Table 10.5.5.2.4-1 shall apply where the cap is, or is not, in contact with the ground.

The efficiency of groups of drilled shafts in cohesive soil may be less than that of the individual shaft due to the overlapping zones of shear deformation in the soil surrounding the shafts.

The resistance factors for the group resistance calculated using the sum of the individual drilled shaft resistances are the same as those for the single-drilled shaft resistances.

10.8.3.6.3—Cohesionless Soil

The individual nominal resistance of each shaft in a group should be reduced by applying an adjustment factor η taken as shown in Table 10.8.3.6.3-1.

For intermediate spacings, the value of η may be determined by linear interpolation.

C10.8.3.6.3

The bearing resistance of drilled shaft groups in sand is less than the sum of the individual shafts due to overlap of shear zones in the soil between adjacent shafts and loosening of the soil during construction. The recommended reduction factors are based in part on theoretical considerations and on limited load test results. See O'Neill and Reese (1999) for additional details and a summary of group load test results. It should be noted that most of the available group load test results were obtained for sands above the water table and for relatively small groups, e.g., groups of 3–9 shafts. For larger shaft groups or for shaft groups of any size below the water table, more conservative values of η should be considered.

These reduction factors presume that good shaft installation practices are used to minimize or eliminate the relaxation of the soil between shafts and caving. If this cannot be adequately controlled due to difficult soil conditions or for other reasons, lower group reduction factors should be considered, or steps should be taken during and after shaft construction to restore the soil to its original condition.

Table 10.8.3.6.3-1—Group Reduction Factors for Bearing Resistance of Shafts in Sand

Shaft Group Configuration	Shaft Center-to-Center Spacing	Special Conditions	Reduction Factor for Group Effects, η
Single Row	2D		0.90
	3D or more		1.0
Multiple Row	2.5D		0.67
	3D		0.80
	4D or more		1.0
Single and Multiple Rows	2D or more	Shaft group cap in intimate contact with ground consisting of medium dense or denser soil, and no scour below the shaft cap is anticipated	1.0
Single and Multiple Rows	2D or more	Pressure grouting is used along the shaft sides to restore lateral stress losses caused by shaft installation, and the shaft tip is pressure grouted	1.0

10.8.3.6.4—Shaft Groups in Strong Soil Overlying Weak Soil

For shaft groups that are collectively tipped within a strong soil layer overlying a soft, cohesive layer, block bearing resistance shall be evaluated in accordance with Article 10.7.3.9.

10.8.3.7—Uplift Resistance

10.8.3.7.1—General

Uplift resistance shall be evaluated when upward loads act on the drilled shafts. Drilled shafts subjected to uplift forces shall be investigated for resistance to pullout, for their structural strength, and for the strength of their connection to supported components.

10.8.3.7.2—Uplift Resistance of Single Drilled Shaft

The uplift resistance of a single straight-sided drilled shaft should be estimated in a manner similar to that for determining side resistance for drilled shafts in compression, as specified in Article 10.8.3.3.

In determining the uplift resistance of a belled shaft, the side resistance above the bell should conservatively be neglected if the resistance of the bell is considered, and it can be assumed that the bell behaves as an anchor.

The factored nominal uplift resistance of a belled drilled shaft in a cohesive soil, R_R , in kips, should be determined as:

$$R_R = \phi R_n = \phi_{up} R_{s\text{bell}} \tag{10.8.3.7.2-1}$$

in which:

$$R_{s\text{bell}} = q_{s\text{bell}} A_u \tag{10.8.3.7.2-2}$$

where:

$$q_{s\text{bell}} = N_u S_u \text{ (ksf)}$$

$$A_u = \pi(D_p^2 - D^2)/4 \text{ (ft}^2\text{)}$$

$$N_u = \text{uplift adhesion factor (dim)}$$

$$D_p = \text{diameter of the bell (ft)}$$

$$D_b = \text{depth of embedment in the founding layer (ft)}$$

$$D = \text{shaft diameter (ft)}$$

$$S_u = \text{undrained shear strength averaged over a distance of } 2.0D_p \text{ above the base (ksf)}$$

$$\phi_{up} = \text{resistance factor specified in Table 10.5.5.2.4-1}$$

If the soil above the founding stratum is expansive, S_u should be averaged over the lesser of either $2.0D_p$ above the bottom of the base or over the depth of penetration of the drilled shaft in the founding stratum.

C10.8.3.7.2

The resistance factors for uplift are lower than those for axial compression. One reason for this is that drilled shafts in tension unload the soil, thus reducing the overburden effective stress and hence the uplift side resistance of the drilled shaft. Empirical justification for uplift resistance factors is provided in Article C10.5.5.2.3, and in Allen (2005).

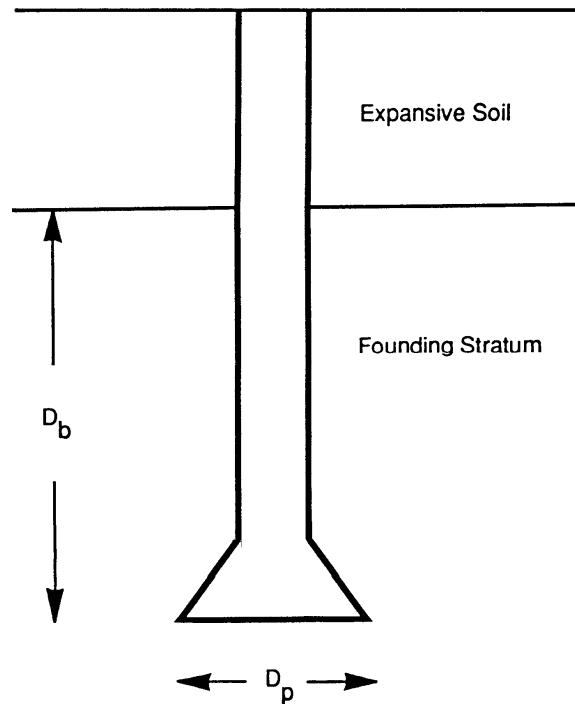

Figure C10.8.3.7.2-1—Uplift of a Belled Drilled Shaft

The value of N_u may be assumed to vary linearly from 0.0 at $D_b/D_p = 0.75$ to a value of 8.0 at $D_b/D_p = 2.5$, where D_b is the depth below the founding stratum. The top of the founding stratum should be taken at the base of zone of seasonal moisture change.

10.8.3.7.3—Group Uplift Resistance

The provisions of Article 10.7.3.11 shall apply.

10.8.3.7.4—Uplift Load Test

The provisions of Article 10.7.3.10 shall apply.

10.8.3.8—Nominal Horizontal Resistance of Shaft and Shaft Groups

The provisions of Article 10.7.3.12 apply.

The design of horizontally loaded drilled shafts shall account for the effects of interaction between the shaft and ground, including the number of shafts in the group.

For shafts used in groups, the drilled shaft head shall be fixed into the cap.

10.8.3.9—Shaft Structural Resistance

10.8.3.9.1—General

The structural design of drilled shafts shall be in accordance with the provisions of Section 5 for the design of reinforced concrete.

10.8.3.9.2—Buckling and Lateral Stability

The provisions of Article 10.7.3.13.4 shall apply.

10.8.3.9.3—Reinforcement

Where the potential for lateral loading is insignificant, drilled shafts may be reinforced for axial loads only. Those portions of drilled shafts that are not supported laterally shall be designed as reinforced concrete columns in accordance with Article 5.7.4. Reinforcing steel shall extend a minimum of 10.0 ft below the plane where the soil provides fixity.

Where the potential for lateral loading is significant, the unsupported portion of the shaft shall be designed in accordance with Articles 5.10.11 and 5.13.4.6.

The minimum spacing between longitudinal bars, as well as between transverse bars or spirals, shall be sufficient to allow free passage of the concrete through the cage and into the annulus between the cage and the borehole wall.

The assumed variation of N_u is based on Yazdanbod et al. (1987).

This method does not include the uplift resistance contribution due to soil suction and the weight of the shaft.

C10.8.3.7.4

See commentary to Article 10.7.3.10.

C10.8.3.8

See commentary to Article 10.7.3.12.

C10.8.3.9.2

See commentary to Article 10.7.3.13.4.

C10.8.3.9.3

Shafts constructed using generally accepted procedures are not normally stressed to levels such that the allowable concrete stress is exceeded. Exceptions include:

- Shafts with sockets in hard rock,
- Shafts subjected to lateral loads,
- Shafts subjected to uplift loads from expansive soils or direct application of uplift loads, and
- Shafts with unreinforced bells.

Maintenance of the spacing of reinforcement and the maximum aggregate size requirements are important to ensure that the high-slump concrete mixes normally used for drilled shafts can flow readily between the steel bars during concrete placement. See Article 5.13.4.5.2 for specifications regarding the minimum clear spacing required between reinforcing cage bars.

A shaft can be considered laterally supported:

- Below the zone of liquefaction or seismic loads,
- In rock, or
- 5.0 ft below the ground surface or the lowest anticipated scour elevation.

Laterally supported does not mean fixed. Fixity would occur somewhat below this location and depends on the stiffness of the supporting soil.

The out-to-out dimension of the assembled reinforcing cage should be sufficiently smaller than the diameter of the drilled hole to ensure free flow of concrete around the reinforcing as the concrete is placed. See Article 5.13.4.

See commentary to Article 10.7.5 regarding assessment of corrosivity. In addition, consideration should be given to the ability of the concrete and steel shell to bond together.

The minimum requirements to consider the steel shell to be load carrying shall be as specified in Article 5.13.4.5.2.

10.8.3.9.4—Transverse Reinforcement

Transverse reinforcement may be constructed as hoops of spiral steel.

Seismic provisions shall be in accordance with Article 5.13.4.6.

10.8.3.9.5—Concrete

The maximum aggregate size, slump, wet or dry placement, and necessary design strength should be considered when specifying shaft concrete. The concrete selected should be capable of being placed and adequately consolidated for the anticipated construction condition, and shaft details should be specified. The maximum size aggregate shall meet the requirements of Article 10.8.3.9.3.

10.8.3.9.6—Reinforcement into Superstructure

Sufficient reinforcement shall be provided at the junction of the shaft with the shaft cap or column to make a suitable connection. The embedment of the reinforcement into the cap shall comply with the provision for cast-in-place piles in Section 5.

10.8.3.9.7—Enlarged Bases

Enlarged bases shall be designed to ensure that the plain concrete is not overstressed. The enlarged base shall slope at a side angle not greater than 30 degrees from the vertical and have a bottom diameter not greater than three times the diameter of the shaft. The thickness of the bottom edge of the enlarged base shall not be less than 6.0 in.

10.8.4—Extreme Event Limit State

The provisions of Article 10.5.5.3 and 10.7.4 shall apply.

C10.8.3.9.5

When concrete is placed in shafts, vibration is often not possible except for the uppermost cross-section. Vibration should not be used for high slump concrete.

C10.8.4

See commentary to Articles 10.5.5.3 and 10.7.4.

10.9—MICROPILES

10.9.1—General

The provisions of Article 10.7.1 shall apply, except as noted herein.

Micropiles shall be classified by type based on their method of installation as follows:

- Type A micropiles are constructed by placing a sand-cement mortar or neat cement grout in the pile under a gravity head only;
- Type B micropiles are constructed by injecting a neat cement grout under pressure (typically 6–21 ksf) into the drilled hole while the temporary drill casing or auger is withdrawn;
- Type C micropiles are grouted as for Type A, followed 15–25 min after primary grouting by injection of additional grout under pressure (typically greater than 21 ksf) via a preplaced sleeved grout pipe.
- Type D micropiles are grouted similar to Type C, but the primary grout is allowed to harden before injecting the secondary grout under pressure (typically 42–170 ksf) with a packer to achieve treatment of specific pile intervals or material horizons; or
- Type E micropiles are constructed by drilling with grout injection through a continuous-thread, hollow-core steel bar. The grout injection serves to flush cuttings, achieve grout penetration into the ground and stabilize the drill hole. Often the initial grout has a high water to cement ratio and is then replaced with a thicker structural grout near the completion of drilling.

Primary grout, where it provides direct load transfer along the micropile to the surrounding ground, shall be Portland cement-based grout injected into the micropile hole before or after reinforcement installation.

Post grouting, also known as regrouting or secondary grouting, shall be taken as the injection of additional Portland cement grout into the bond length of the micropile after set up of primary grout to enhance the grout–ground bond.

C10.9.1

Micropiles should be considered:

- Where footings cannot be founded on rock, stiff cohesive, or granular foundation material at a reasonable expense;
- At locations where soil conditions would normally permit the use of spread footings, but the potential for erosion exists;
- At locations where pile foundations must penetrate rock;
- At locations where difficult subsurface conditions (e.g., cobbles, boulders, debris fill, running sands) would hinder installation of driven piles or drilled shafts;
- At locations where difficult access or limited headroom preclude use of other deep foundation systems;
- At locations where foundations must bridge over or penetrate subsurface voids;
- Where vibration limits preclude conventional pile driving operations or access by drilled shaft rigs; or
- When underpinning or retrofitting existing foundations.

A typical detail for a composite reinforced micropile is illustrated in Figure C10.9.1-1.

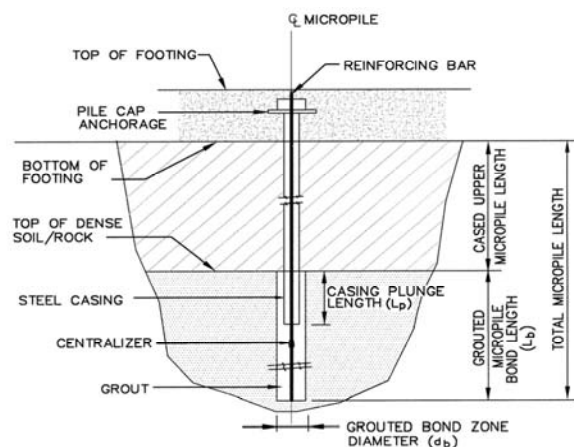

Figure C10.9.1-1—Typical Detail of Composite Reinforced Micropile (after Sabatini, et al., 2005)

10.9.1.1—Scope

The provisions of this Article shall apply to the design of micropiles.

The provisions of this section shall not be taken as applicable to drilled piles, e.g., augercast piles, installed with continuous flight augers that are concreted as the auger is being extracted.

10.9.1.2—Minimum Micropile Spacing, Clearance, and Embedment into Cap

Center-to-center pile spacing should not be less than 30.0 in. or 3.0 pile diameters, whichever is greater. Otherwise, the provisions of Article 10.7.1.2 shall apply.

10.9.1.3—Micropiles through Embankment Fill

Micropiles extending through embankments shall penetrate a minimum of 10.0 ft into original ground, unless the required nominal axial and lateral resistance occurs at a lesser penetration below the embankment within bedrock or other suitable support materials.

10.9.1.4—Battered Micropiles

The provisions of Article 10.7.1.4 shall apply.

10.9.1.5—Micropile Design Requirements

Micropile design shall address the following issues as appropriate:

- Nominal axial resistance to be specified in the contract and size of micropile group required to provide adequate support, with consideration of how nominal axial micropile resistance will be determined in the field;
- Group interaction;
- Pile quantity estimation from estimated pile penetration required to meet nominal axial resistance and other design requirements;
- Minimum pile penetration necessary to satisfy the requirements caused by uplift, scour, downdrag, settlement, liquefaction, lateral loads, and seismic conditions;
- Foundation deflection to meet the established movement and associated structure performance criteria;
- Pile foundation nominal structural resistance; and
- Long-term durability of the micropile in service, i.e. corrosion and deterioration.

C10.9.1.3

If compressible soils are located beneath the embankment, micropiles should be installed after embankment settlement is complete, if possible, to minimize or eliminate downdrag forces.

C10.9.1.4

See Article C10.7.1.4.

C10.9.1.5

The micropile design process is discussed in detail in *Micropile Design and Construction* (Sabatini, et al., 2005).

10.9.1.6—Determination of Micropile Loads	C10.9.1.6
The provisions of Article 10.7.1.6 shall apply.	See Article C10.7.1.6.
<i>10.9.1.6.1—Downdrag</i>	<i>C10.9.1.6.1</i>
The provisions of Articles 10.7.1.6.2 and 3.11.8 shall apply.	See Articles C10.7.1.6.2 and C3.11.8.
<i>10.9.1.6.2—Uplift Due to Expansive Soils</i>	<i>C10.9.1.6.2</i>
The provisions in Article 10.7.1.6.3 shall apply.	See Article C10.7.1.6.3.
<i>10.9.1.6.3—Nearby Structures</i>	
The provisions of Article 10.7.1.6.4 shall apply.	
10.9.2—Service Limit State Design	
10.9.2.1—General	C10.9.2.1
The provisions of Article 10.7.2.1 shall apply.	See Article C10.7.2.1.
10.9.2.2—Tolerable Movements	C10.9.2.2
The provisions of Articles 10.5.2.1 and 10.5.2.2 shall apply.	See Articles C10.5.2.1 and C10.5.2.2.
10.9.2.3—Settlement	C10.9.2.3
The provisions of Article 10.7.2.3 shall apply.	See Article C10.7.2.3. Methods for calculating the settlement of micropiles are discussed in Sabatini, et al. (2005).
<i>10.9.2.3.1—Micropile Groups in Cohesive Soil</i>	<i>C10.9.2.3.1</i>
The provisions of Article 10.7.2.3.1 shall apply.	See Article 10.7.2.3.1.
<i>10.9.2.3.2—Micropile Groups in Cohesionless Soil</i>	<i>C10.9.2.3.2</i>
The provisions of Article 10.7.2.3.2 shall apply.	See Article C10.7.2.3.2.
10.9.2.4—Horizontal Micropile Foundation Movement	C10.9.2.4
The provisions of Articles 10.5.2.1 and 10.7.2.4 shall apply.	See Articles C10.5.2.1 and C10.7.2.4.
10.9.2.5—Settlement Due to Downdrag	C10.9.2.5
The provisions of Article 10.7.2.5 shall apply.	See Article C10.7.2.5.
10.9.2.6—Lateral Squeeze	C10.9.2.6
The provisions of Article 10.7.2.6 shall apply.	See Article C10.7.2.6.

10.9.3—Strength Limit State Design**10.9.3.1—General****C10.9.3.1**

For strength limit state design, the following shall be determined:

- Loads and performance requirements;
- Micropile dimensions and nominal axial micropile resistance;
- Size and configuration of the micropile group to provide adequate foundation support;
- Estimated micropile length to be used in the construction contract documents to provide a basis for bidding;
- A minimum micropile penetration, if required, for the particular site conditions and loading, determined based on the maximum (deepest) penetration needed to meet all of the applicable requirements identified in Article 10.7.6; and
- The nominal structural resistance of the micropile and/or micropile group.

A minimum micropile penetration should only be specified if needed to insure that uplift, lateral stability, depth to resist downdrag, depth to resist scour, and depth for structural lateral resistance are met for the strength limit state, in addition to similar requirements for the service and extreme event limit states. See Article C10.7.6 for additional details.

Punching of micropiles through strong soil into a weaker layer is not likely for micropiles designed for a resistance by bond transfer only.

10.9.3.2—Ground Water Table and Bouyancy**C10.9.3.2**

The provisions of Article 10.7.3.4 shall apply.

See Article C10.7.3.4.

10.9.3.3—Scour**C10.9.3.3**

The provisions of Article 10.7.3.5 shall apply.

See Article C10.7.3.5.

10.9.3.4—Downdrag**C10.9.3.4**

The provisions of Article 10.7.3.6 shall apply.

See Article C10.7.3.6.

10.9.3.5—Nominal Axial Compression Resistance of a Single Micropile*10.9.3.5.1—General**C10.9.3.5.1*

Micropiles shall be designed to resist failure of the bonded length in soil and rock, or for micropiles bearing on rock, failure of the rock at the micropile tip.

The factored resistance of a micropile, R_R , shall be taken as:

$$R_R = \phi R_n = \phi_{qp} R_p + \phi_{qs} R_s \quad (10.9.3.5.1-1)$$

Micropiles are typically designed based on bond into soil and rock neglecting tip resistance due to their relatively small diameter and high grout-to-ground bond resistance. Tip resistance may be considered for micropiles bearing on hard rock although the axial capacity for this case is often controlled by the structural resistance of the micropile.

in which:

$$R_p = q_p A_p \quad (10.9.3.5.1-2)$$

$$R_s = q_s A_s \quad (10.9.3.5.1-3)$$

where:

R_p = nominal tip resistance (kips)

R_s = nominal grout-to-ground bond resistance (kips)

Φ_{qp} = resistance factor for tip resistance specified in Table 10.5.5.2.5-1

Φ_{qs} = resistance factor for grout-to-ground bond resistance specified in Table 10.5.5.2.5-1

q_p = unit tip resistance (ksf)

q_s = unit grout-to-ground bond resistance (ksf)

A_p = area of micropile tip (ft²)

A_s = area of grout-to-ground bond surface (ft²)

For final design, micropile resistance shall be verified through the performance of micropile load tests as described in Article 10.9.3.5.4. The resistance factors for micropiles shall be taken as specified in Table 10.5.5.2.5-1.

10.9.3.5.2—Estimation of Grout-to-Ground Bond Resistance

C10.9.3.5.2

The nominal grout-to-ground bond resistance over the bonded length of a micropile, R_s , in kips shall be taken as:

$$R_s = \pi d_b \alpha_b L_b \quad (10.9.3.5.2-1)$$

where:

d_b = diameter of micropile drill hole through bonded length (ft)

α_b = nominal micropile grout-to-ground bond strength (ksf)

L_b = micropile bonded length (ft)

For final design, micropile capacity shall be verified through the performance of micropile load tests as described in Article 10.9.3.5.4.

Both the tip and bond resistances develop in response to foundation displacement. The maximum values of each are unlikely to occur at the same displacement. The bond resistance is typically fully mobilized at displacements of about 0.1 to 0.4 in. The tip capacity, however, is mobilized after the micropile settles about six percent of its diameter (Jeon and Kulhawy, 2001), and is generally neglected in the design of micropiles in soil.

The methods for estimating micropile axial resistance provided in this article should be used. Micropile strength limit state resistance methods not specifically addressed in this Article for which adequate regional or national experience is available may be used, provided adequate information and experience is also available to develop appropriate resistance factors.

The value of nominal unit grout-to-ground bond strength, either estimated empirically or determined through load testing, is typically taken as the average value over the entire bond length.

Micropile grout-to-ground bond strength is influenced by soil and rock conditions, method of micropile drilling and installation, and grouting pressure. The final micropile geotechnical design should be performed by a specialty contractor qualified to perform micropile design and construction. As a guide, Table C10.9.3.5.2-1 may be used to estimate the nominal (ultimate) unit grout-to-ground bond strength for Types A, B, C, D, and E micropiles bonded into soil and/or rock for preliminary design.

For preliminary design, the grout-to-ground bond resistance of micropiles may be based on the results of micropile load tests; estimated based on a review of geologic and boring data, soil and rock samples, laboratory testing, and previous experience; or estimated using published soil/rock-grout bond guidelines.

Table C10.9.3.5.2-1—Summary of Typical α_b Values (Grout-to-Ground Bond) for Preliminary Micropile Design (modified after Sabatini, et al., 2005)

Soil/Rock Description	Typical Range of Grout-to-Ground Bond Nominal Resistance for Micropile Types ⁽¹⁾ (ksf)				
	Type A	Type B	Type C	Type D	Type E
Silt & Clay (some sand) (soft medium plastic)	0.7–1.4	0.7–2.0	0.7–2.5	0.7–3.0	0.7–2.0
Silt & Clay (some sand) (stiff, dense to very dense)	0.7–2.5	1.4–4.0	2.0–4.0	2.0–4.0	1.4–4.0
Sand (some silt) (fine, loose-medium dense)	1.4–3.0	1.4–4.0	2.0–4.0	2.0–5.0	1.4–5.0
Sand (some silt, gravel) (fine-coarse, medium-very dense)	2.0–4.5	2.5–7.5	3.0–7.5	3.0–8.0	2.5–7.5
Gravel (some sand) (medium-very dense)	2.0–5.5	2.5–7.5	3.0–7.5	3.0–8.0	2.5–7.5
Glacial Till (silt, sand, gravel) (medium-very dense, cemented)	2.0–4.0	2.0–6.5	2.5–6.5	2.5–7.0	2.0–6.5
Soft Shales (fresh-moderate fracturing, little to no weathering)	4.3–11.5	N/A	N/A	N/A	N/A
Slates and Hard Shales (fresh- moderate fracturing, little to no weathering)	10.8–28.8	N/A	N/A	N/A	N/A
Limestone (fresh-moderate fracturing, little to no weathering)	21.6–43.2	N/A	N/A	N/A	N/A
Sandstone (fresh-moderate fracturing, little to no weathering)	10.8–36.0	N/A	N/A	N/A	N/A
Granite and Basalt (fresh-moderate fracturing, little to no weathering)	28.8–87.7	N/A	N/A	N/A	N/A

⁽¹⁾ Refer to Article 10.9.1 for description of micropile types.

10.9.3.5.3—Estimation of Micropile Tip Resistance in Rock

The methods used for design of micropiles bearing on rock shall consider the presence, orientation, and condition of discontinuities, weathering profiles, and other similar profiles as they apply at a particular site. The designer shall judge the competency of a rock mass in accordance with the provisions of Article 10.4.6.4.

For micropiles founded on competent rock, tip resistance may be estimated in accordance with the provisions of Article 10.8.3.5.4c.

C10.9.3.5.3

Micropiles are generally designed based on bond into rock rather than tip resistance. Tip resistance is generally considered only for micropiles bearing on competent rock.

For micropiles founded on competent rock, the rock is usually so sound that the structural capacity will govern the design.

Weak rock includes some shales and mudstones or poor-quality weathered rocks. The term “weak” has no generally accepted, quantitative definition; therefore, judgment and experience are required to make this determination.

10.9.3.5.4—Micropile Load Test

The load test shall follow the procedures specified in ASTM D1143 for compression and ASTM D3689 for tension. The loading procedure should follow the Quick Load Test Method, unless detailed longer-term load-settlement data is needed, in which case the standard loading procedure should be used. Unless specified otherwise by the Engineer, the pile axial resistance shall be determined from the test data using the Davisson Method as presented in Article 10.7.3.8.2.

The number of load tests required to account for site variability shall be as specified in Article 10.5.5.2.2. The number of test micropiles required should be increased in nonuniform subsurface conditions.

In addition, proof tests loaded to the required factored load shall be performed on one pile per substructure unit or five percent of the piles, whichever is greater, unless specified otherwise by the Engineer.

The resistance factors for axial compressive resistance or axial uplift resistance shall be taken as specified in Table 10.5.5.2.5-1.

10.9.3.6—Resistance of Micropile Groups in Compression

Reduction in resistance from group effects shall be evaluated in accordance with the provisions of Article 10.7.3.9.

10.9.3.7—Nominal Uplift Resistance of a Single Micropile

Uplift resistance shall be evaluated when upward loads act on the micropiles. Micropiles subjected to uplift forces shall be investigated for resistance to pullout, for their structural strength, and for the strength of their connection to supported components.

10.9.3.8—Nominal Uplift Resistance of Micropile Groups

The provisions of Article 10.7.3.11 shall apply.

C10.9.3.5.4

See Article C10.8.3.5.6.

Load Tests on micropiles are performed to determine micropile installation characteristics, evaluate micropile capacity with depth, and establish micropile bond lengths.

During the performance of ASTM tests, the Contractor may perform several load cycles on the test micropile for diagnostic purposes.

Test micropiles may not be required where previous experience exists with the same micropile type and ultimate micropile capacity in similar subsurface conditions. However, load tests can differ even for apparently similar ground conditions. Therefore, care should be exercised in generalizing and extrapolating the test results to other locations.

Test micropiles are frequently planned for each substructure.

With approval of the Engineer, the number of load tests and proof tests can be reduced based on:

- Previous micropile load tests in similar ground using similar methods, or
- Site-specific tests showing much higher than required factored resistance or consistent proof test.

C10.9.3.6

See Article C10.7.3.9.

C10.9.3.7

Resistance factors in Article 10.5.5.2.5 assume a tension load test is performed. In the event that tension load tests are not performed, the resistance factor for presumptive values may be used or the tension resistance estimated as 50 percent of the compression resistance.

C10.9.3.8

Group uplift resistance in rock should consider the depth of soil overburden, rock discontinuity spacing and condition, and rock mass shear strength, as well as bond between micropiles and rock.

10.9.3.9—Nominal Horizontal Resistance of Micropiles and Micropile Groups

The provisions of Article 10.7.3.12 apply.

The design of horizontally loaded micropiles shall account for the effects of interaction between the micropiles and ground, including the number and spacing of micropiles in the group.

For micropiles used in groups, the micropile head shall be embedded into the cap and the degree of fixity shall be considered in the design.

10.9.3.10—Structural Resistance

10.9.3.10.1—General

The structural design of micropiles shall be in accordance with the provisions of Section 5 for the design of reinforced concrete and Section 6 for the design of steel.

The cased and uncased length of each micropile shall be designed to resist the forces distributed to the micropile based on the micropile inclination and spacing.

The resistance factors for structural design shall be as specified in Table 10.5.5.2.5-2.

10.9.3.10.2—Axial Compressive Resistance

The upper cased section of a micropile subjected to compression loading shall be designed structurally to support the full factored load on the micropile. The lower uncased section of a micropile subjected to compression loading shall be designed structurally to support the maximum full factored load on the micropile less the load transferred to the surrounding ground from the cased portion of the pile in the plunge length (if used), as described in Article 10.9.3.10.4.

For micropiles extending through a weak upper soil layer, extending above ground, subject to scour, extending through mines/caves, or extending through soil that may liquefy, the effect of any laterally unsupported length shall be considered in the determination of axial compression resistance.

The factored structural resistance of a micropile to axial compression loading, R_C , in kips may be taken as:

$$R_C = \phi_C R_n \quad (10.9.3.10.2-1)$$

where:

ϕ_C = resistance factor specified in Table 10.5.5.2.5-2 for structural resistance of micropiles in axial compression

R_n = nominal axial compression resistance of micropile specified in Articles 10.9.3.10.2a and 10.9.3.10.2b (kips)

C10.9.3.9

See Article C10.7.3.12.

C10.9.3.10.1

Articles 5.6.3.4, 5.7.4, 5.7.6, 5.13.4, and 6.15 provide specific provisions applicable to design of concrete and steel micropiles.

The design of micropiles supporting axial compression load only requires an allowance for unintended eccentricity. This has been accounted for by use of the equations in Article 5.7.4.4 for reinforced concrete columns that already contain an eccentricity allowance.

10.9.3.10.2a—Cased Length

The factored structural resistance of the upper cased length of a micropile having no unsupported length and loaded in compression, R_{CC} , in kips may be taken as:

$$R_{CC} = \phi_{CC} R_n \quad (10.9.3.10.2a-1)$$

for which:

$$R_n = 0.85 \left[0.85 f'_c A_g + f_y (A_b + A_c) \right] \quad (10.9.3.10.2a-2)$$

where:

ϕ_{CC} = resistance factor specified in Table 10.5.5.2.5-2 for structural resistance of the cased section of a micropile subjected to compression loading

f'_c = specified compressive strength of micropile grout at 28 days unless another age is specified (ksi)

A_g = cross-sectional area of grout within micropile (in.²)

f_y = specified minimum yield strength of reinforcement bar or steel casing, or stress in steel reinforcement bar or casing at a strain of 0.003, whichever is less (ksi)

A_b = cross-sectional area of steel reinforcing bar (in.²)

A_c = cross-sectional area of steel casing (in.²)

10.9.3.10.2b—Uncased Length

The factored structural resistance of the lower, uncased length of a micropile having no unsupported length and loaded in compression, R_{CU} , in kips may be taken as:

$$R_{CU} = \phi_{CU} R_n \quad (10.9.3.10.2b-1)$$

for which:

$$R_n = 0.85 \left[0.85 f'_c A_g + f_y A_b \right] \quad (10.9.3.10.2b-2)$$

where:

ϕ_{CU} = resistance factor specified in Table 10.5.5.2.5-2 for structural resistance of the uncased section of a micropile subjected to compression loading

f'_c = specified compressive strength of micropile grout at 28 days unless another age is specified (ksi)

C10.9.3.10.2a

The design compressive stress in the steel is limited to the stress at which the strain equals 0.003 to maintain compatibility with the strain in the grout.

A_g = cross-sectional area of grout within micropile (in.²)

f_y = specified minimum yield strength of reinforcement bar or stress in steel reinforcement bar at a strain of 0.003, whichever is less (ksi)

A_b = cross-sectional area of steel reinforcing bar (in.²)

10.9.3.10.3—Axial Tension Resistance

The upper cased section of a micropile subjected to tension loading shall be designed structurally to support the full factored load on the micropile. The lower uncased section of a micropile subjected to tension loading shall be designed structurally to support the maximum full factored load on the micropile less the load transferred to the surrounding ground from the cased portion of the micropile in the plunge length, as described in Article 10.9.3.10.4.

The factored structural resistance of a micropile subjected to tension, R_T , may be taken as:

$$R_T = \phi_T R_n \quad (10.9.3.10.3-1)$$

where:

ϕ_T = resistance factor specified in Table 10.5.5.2.5-2 for structural resistance of a micropile subjected to tension loading (dim)

R_n = nominal axial tension resistance of micropile specified in Articles 10.9.3.10.3a and 10.9.3.10.3b

10.9.3.10.3a—Cased Length

The factored structural resistance of the upper cased length of a micropile subjected to tension loading, R_{TC} , in kips may be taken as:

$$R_{TC} = \phi_{TC} R_n \quad (10.9.3.10.3a-1)$$

for which:

$$R_n = f_y (A_b + A_{ct}) \quad (10.9.3.10.3a-2)$$

where:

ϕ_{TC} = resistance factor specified in Table 10.5.5.2.5-2 for structural resistance of the cased section of a micropile subjected to tension loading (dim)

f_y = specified minimum yield strength of reinforcement bar or steel casing, whichever is less (ksi)

A_b = cross-sectional area of steel reinforcing bar (in.²)

A_{ct} = cross-sectional area of steel casing considering reduction for threads (in.²)

C10.9.3.10.3a

The design compressive stress in the steel is limited to the stress at which the strain equals 0.003 to maintain compatibility with the strain in the grout.

10.9.3.10.3b—Uncased Length

The factored structural resistance of the lower uncased length of a micropile subjected to tension loading, R_{TU} , in kips may be taken as:

$$R_{TU} = \phi_{TU} R_n \quad (10.9.3.10.3b-1)$$

for which:

$$R_n = f_y A_b \quad (10.9.3.10.3b-2)$$

where:

ϕ_{TU} = resistance factor specified in Table 10.5.5.2.5-2 for structural resistance of the uncased section of a micropile subjected to tension loading (dim)

f_y = specified minimum yield strength of reinforcement bar (kip)

A_b = cross-sectional area of steel reinforcing bar (in.²)

10.9.3.10.4—Plunge Length Transfer Load

C10.9.3.10.4

The factored axial load transferred to the ground through the plunge length of the cased portion of a micropile, P_t , in kips, may be taken as:

$$P_t = \phi [\pi d_b \alpha_b L_p] \quad (10.9.3.10.4-1)$$

where:

ϕ = resistance factor specified in Table 10.5.5.2.5-1 for geotechnical bearing or uplift resistance, as appropriate, of a single micropile

d_b = diameter of micropile drill hole through bonded length (ft)

α_b = nominal micropile grout-to-ground bond strength (ksf)

L_p = micropile casing plunge length (ft)

If load transfer through the plunge length of the cased portion of a micropile is considered to reduce the load on the lower uncased portion of the micropile, the factored axial load on the uncased portion of the micropile in compression or tension, P_u , in kips, may be taken as:

$$P_u = Q - P_t \quad (10.9.3.10.4-2)$$

where:

$Q = \sum \eta_i \gamma_i Q_i$
= total factored axial load on micropile (kips)

An optional procedure for construction of a composite reinforced micropile includes insertion of the pile casing into the top of the grouted bond zone to effect a transition between the upper cased portion to the lower uncased portion of a micropile. The length of casing inserted into the bond zone by the plunge length is shown in Figure C10.9.1-1. As a result, a portion of the factored axial load on a micropile is transferred to the surrounding ground by the cased portion of the pile, reducing the load that must be supported by the weaker uncased portion of the pile. The reduction in load applied to the uncased length is termed the transfer load P_t .

P_t = plunge length transfer load from
Eq. 10.9.3.10.4-1 (kips)

10.9.3.10.5—Grout-to-Steel Bond

Casing-to-grout bond shall be checked and reinforcement bar development length shall be checked in accordance with the provisions of Section 5.

C10.9.3.10.5

Grout-to-steel bond does not typically govern micropile design, except for overlap of reinforcing bars into upper casing.

The bond between the cement grout and the reinforcing steel is the mechanism for transfer of the pile load from the reinforcing steel to the ground. Typical ultimate bond values range from 0.15 to 0.25 ksi for smooth bars and pipe, and 0.30 to 0.50 ksi for deformed bars (Armour, et al., 2000). Refer to Section 5 for bar development requirements.

As is the case with any reinforcement, the surface condition will affect the attainable bond. A film of rust may be beneficial, but the presence of loose debris or lubricant or paint is not desirable. Normal methods for the handling and storage of reinforcing bars apply to micropile construction. For the permanent casing that is also used to drill the hole, cleaning of the casing surface can occur during drilling, particularly in granular soils.

10.9.3.10.6—Buckling and Lateral Stability

The provisions of Article 10.7.3.13.4 shall apply.

10.9.3.10.7—Reinforcement into Superstructure

Sufficient reinforcement shall be provided at the junction of the micropile with the micropile footing or column to make a suitable connection. The embedment of the reinforcement into the cap shall comply with the provision for cast-in-place piles in Section 5.

C10.9.3.10.7

Refer to Sabatini, et al. (2005) for typical micropile to footing connection details.

10.9.4—Extreme Event Limit State

The provisions of Articles 10.5.5.3 and 10.7.4 shall apply.

C10.9.4

See Articles C10.5.5.3 and C10.7.4.

10.9.5—Corrosion and Deterioration

The provisions of Article 10.7.5 shall apply.

C10.9.5

Corrosion protection methods and design presented in Article C10.7.5 apply to micropiles as well. In addition, other micropile specific design options including plastic encapsulation of central reinforcing bars is provided in Sabatini (2005).

10.10—REFERENCES

AASHTO. 1988. *Manual on Subsurface Investigations*, First Edition, MSI-1. American Association of State Highway and Transportation Officials, Washington, DC.

AASHTO. 2002. *Standard Specifications for Highway Bridges*, 17th Edition, HB-17. American Association of State Highway and Transportation Officials, Washington, DC.

AASHTO. 2011. *AASHTO Guide Specifications for LRFD Seismic Design*, Second Edition, LRFDSEIS-2. American Association of State Highway and Transportation Officials, Washington, DC.

- Allen, T. M. 2005. *Development of Geotechnical Resistance Factors and Downdrag Load Factors for LRFD Foundation Strength Limit State Design*, FHWA-NHI-05-052, Federal Highway Administration, U.S. Department of Transportation, Washington, DC.
- Allen, T. M., 2007, "Development of New Pile-Driving Formula and Its Calibration for Load and Resistance Factor Design," *Transportation Research Record: Journal of the Transportation Research Board*, No. 2004, Transportation Research Board of the National Academies, Washington, D.C., pp. 20–27.
- Arman, A., N. Samtani, R. Castelli, and G. Munfakh. 1997. *Subsurface Investigations: Training Course in Geotechnical and Foundation Engineering*, FHWA-HI-97-021. Federal Highway Administration, U.S. Department of Transportation, Washington, DC.
- Ashour, M., G. M. Norris, and P. Pilling. 1998, "Lateral Loading of a Pile in Layered Soil Using the Strain Wedge Model," *ASCE Journal of Geotechnical and Geoenvironmental Engineering*. American Society of Civil Engineers, Reston, VA, Vol. 124, No. 4, pp. 303–315.
- ASTM D6429, *Standard Guide for Selecting Surface Geophysical Methods*
- Baguelin, F., J. F. Jezequel, and D. H. Shields. 1987. *The Pressuremeter and Foundation Engineering*. Trans Tech Publications, Clausthal-Zellerfeld, Germany, p. 617.
- Barkdale, R. D., and R. C. Bachus. 1983. *Design and Construction of Stone Columns—Vol. 1*, FHWA/RD-83/02C. Federal Highway Administration, U.S. Department of Transportation, Washington, DC.
- Barker, R. M., J. M. Duncan, K. B. Rojiani, P. S. K. Ooi, C. K. Tan, and S. G. Kim. 1991. *Manuals for the Design of Bridge Foundations. NCHRP Report 343*. Transportation Research Board, National Research Council, Washington, DC.
- Barton, N. R. 1976. "The Shear Strength of Rock and Rock Joints," *Engineering Geology*. Elsevier Science Publishing Company, Inc., New York, NY, Vol. 7, pp. 287–332.
- Bieniawski, Z. T. 1984. *Rock Mechanics Design in Mining and Tunneling*. A. A. Balkema, Rotterdam/Boston, p. 272.
- Bogard, J. D., and H. Matlock. 1990. "Application of Model Pile Tests to Axial Pile Design." In *Proc., 22nd Annual Offshore Technology Conference*, Houston, TX, Vol. 3, pp. 271–278.
- Boulanger, R. W., and I. M. Idriss. 2006. "Liquefaction Susceptibility Criteria for Silts and Clays," *Journal of Geotechnical and Geoenvironmental Engineering*. American Society of Civil Engineers, Reston, VA, Vol. 132, No. 11, pp. 1413–1426.
- Bowles, J. E. 1977. *Foundation Analysis and Design*, Second Edition. McGraw–Hill Book Company, New York, NY.
- Bowles, J. E. 1988. *Foundation Analysis and Design*, 4th Edition. McGraw–Hill Book Company, New York, NY, p. 1004.
- Bray, J. D., and R. B. Sancio. 2006. "Assessment of the Liquefaction Susceptibility of Fine-Grained Soils," *Journal of Geotechnical and Geoenvironmental Engineering*. American Society of Civil Engineers, Reston, VA, Vol. 132, No. 9, pp. 1165–1176.
- Bray, J. D., R.B. Sancio, M. F. Riemer, and T. Durgunoglu. 2004. "Liquefaction Susceptibility of Fine-Grained Soils." In *Proc., 11th International Conference on Soil Dynamics and Earthquake Engineering and 3rd International Conference On Earthquake Geotechnical Engineering*, Berkeley, CA, January 2004, Doolin, Kammerer, Nogami, Seed and Towhata, Eds., Vol. 1, pp. 655–662.
- Broms, B. B. 1964a. "Lateral Resistance of Piles in Cohesive Soil," *ASCE Journal for Soil Mechanics and Foundation Engineering*. American Society of Civil Engineers, Reston, VA, Vol. 90, SM2, pp. 27–63.
- Broms, B.B. 1964b. "Lateral Resistance of Piles in Cohesionless Soil," *ASCE Journal for Soil Mechanics and Foundation Engineering*. American Society of Civil Engineers, Reston, VA, Vol. 90, SM3, pp. 123–156.

- Campanella, R. G. 1994. "Field Methods for Dynamic Geotechnical Testing: An Overview of Capabilities and Needs." In *Dynamic Geotechnical Testing II*, Special Technical Publication No. 1213, American Society for Testing and Materials, Philadelphia, PA, pp. 3–23.
- Canadian Geotechnical Society. 1985. *Canadian Foundation Engineering Manual*, Second Edition. Bitech Publishers, Ltd., Vancouver, British Columbia, Canada, p. 460.
- Carter, J. P., and F. H. Kulhawy. 1988. *Analysis and Design of Foundations Socketed into Rock*, Report No. EL-5918. Empire State Electric Engineering Research Corporation and Electric Power Research Institute, New York, NY, p. 158.
- Cetin, K. O., R. B. Seed, A. Der Kiureghian, K. Tokimatsu, L. F. Harder, R. E. Kayen, and R. E. S. Moss. 2004. "Standard Penetration Test-Based Probabilistic and Deterministic Assessment of Seismic Soil Liquefaction Potential," *Journal of Geotechnical and Geoenvironmental Engineering*. American Society of Civil Engineers, Reston, VA, Vol. 130, No. 12, pp. 1314–1340.
- Cheney, R. and R. Chassie. 2000. *Soils and Foundations Workshop Reference Manual*, NHI-00-045. National Highway Institute, Federal Highway Administration, U.S. Department of Transportation, Washington, DC.
- Davisson, M. T. 1972. "High Capacity Piles." *Proceedings Lecture Series, Innovations in Foundation Construction*, Illinois Section, American Society of Civil Engineers, Reston, VA.
- Davisson, M. T., and K. E. Robinson. 1965. "Bending and Buckling of Partially Embedded Piles." In *Proc., Sixth International Conference S. M. and F. E.* University of Toronto Press, Montreal, Canada, pp. 243–246.
- DiMillio, A. F. 1982. *Performance of Highway Bridge Abutments Supported by Spread Footings on Compacted Fill*, FHWA/RD-81/184 (NTIS PB83-201822). FHWA Staff Study.
- Duncan, J. M., and A. L. Buchignani. 1976. *An Engineering Manual for Settlement Studies*. Department of Civil Engineering, University of California at Berkeley, Berkeley, CA, p. 94. Geotechnical engineering report.
- Duncan, J. M. 2000. "Factors of Safety and Reliability in Geotechnical Engineering," *Journal of Geotechnical and Geoenvironmental Engineering*. American Society of Civil Engineers, Reston, VA, Vol. 126, No. 4, pp. 307–316.
- Elias, V. 1990. *Durability/Corrosion of Soil Reinforced Structures*, FHWA/R-89/186. Federal Highway Administration, U.S. Department of Transportation, Washington, DC, p. 173.
- Elias, V., J. Welsh, J. Warren, and R. Lukas. 2000. *Ground Improvement Technical Summaries—Vols. 1 and 2*, Demonstration Project 116, FHWA-SA-98-086. Federal Highway Administration, U.S. Department of Transportation, Washington, DC.
- EPRI. 1983. *Transmission Line Structure Foundations for Uplift-Compression Loading*, EL-2870. Electric Power Research Institute, Palo Alto, CA.
- Esrig, M. E., and R. C. Kirby. 1979. "Advances in General Effective Stress Method for the Prediction of Axial Capacity for Driven Piles in Clay." In *Proc., 11th Annual Offshore Technology Conference*, pp. 437–449.
- Fang, H. Y. 1991. *Foundation Engineering Handbook*, Second Edition. Van Nostrand Reinhold, New York, NY.
- Gifford, D. G., J. R. Kraemer, J. R. Wheeler, and A. F. McKown. 1987. *Spread Footings for Highway Bridges*, FHWA/RD-86/185. Federal Highway Administration, U.S. Department of Transportation, Washington, DC, p. 229.
- Goodman, R. E. 1989. "Introduction." In *Rock Mechanics*, Second Edition, John Wiley and Sons, Inc., New York, NY, p. 562.
- Hannigan, P. J., G. G. Goble, G. Thendean, G. E. Likins, and F. Rausche. 2006. *Design and Construction of Driven Pile Foundations*, FHWA-NHI-05-042 and NHI-05-043, Federal Highway Administration, U.S. Department of Transportation, Washington, D.C., Vols. I and II.

- Hansen, B. J. 1970. "A Revised and Extended Formula for Bearing Capacity," *Bulletin*. Danish Geotechnical Institute, Copenhagen, Vol. 28.
- Hara, A., T. Ohta, M. Niwa, S. Tanaka, and T. Banno. 1974. "Shear Modulus and Shear Strength of Cohesive Soils," *Soils and Foundations*. Vol. 14, No. 3, pp. 1–12.
- Hoek, E. 1983. "Strength of Jointed Rock Masses," *Geotechnique*. Thomas Telford Ltd., London, Vol. 33, No. 3, pp. 187–223.
- Hoek, E., and E. T. Brown. 1988. "The Hoek-Brown Failure Criterion—A 1988 Update." In *Proc., 15th Canadian Rock Mechanics Symposium*, Toronto, Canada.
- Hoek, E., and E. T. Brown. 1997. "Practical Estimates of Rock Mass Strength," *International Journal of Rock Mechanics and Mining Sciences*. Available at <http://www.roscience.com/>.
- Holtz, R. D., and W. D. Kovacs. 1981. *An Introduction to Geotechnical Engineering*. Prentice-Hall, Englewood Cliffs, NJ.
- Horvath, R. G., and T. C. Kenney. 1979. "Shaft Resistance of Rock Socketed Drilled Piers." In *Proc., Symposium on Deep Foundations*. American Society of Civil Engineers, Atlanta, GA, pp. 182–214.
- Hough, B. K. 1959. "Compressibility as the Basis for Soil Bearing Value," *Journal of the Soil Mechanics and Foundations Division*. American Society of Civil Engineers, Reston, VA, Vol. 85, Part 2.
- Jaeger, J. C., and N. G. W. Cook. 1976. *Fundamentals of Rock Mechanics*. Chapman & Hall, London.
- Janbu, N. 1963. "Soil Compressibility as Determined By Oedometer and Triaxial Tests." In *Proc, 3rd European Conference of Soil Mechanics and Foundation Engineering*. Wiesbaden, Germany, Vol. 1.
- Janbu, N. 1967. "Settlement Calculations Based on Tangent Modulus Concept," *Bulletin No. 2, Soil Mechanics and Foundation Engineering Series*. The Technical University of Norway, Trondheim, Norway, p. 57.
- Kavazanjian, E., Jr., T. Hadj-Hamou Matasoviæ, and P. J. Sabatini. 1997. *Geotechnical Engineering Circular No. 3, Design Guidance: Geotechnical Earthquake Engineering for Highways*, FHWA-SA-97-076, Federal Highway Administration, U.S. Department of Transportation, Washington, DC.
- Kimmerling, R. E. 2002. *Geotechnical Engineering Circular 6, Shallow Foundations*, FHWA-SA-02-054, Federal Highway Administration, U.S. Department of Transportation, Washington, DC.
- Komurka, V. E., A. B. Wagner, and T. B. Edil. 2003. *Estimating Soil/Pile Set-Up*, Wisconsin Highway Research Program #0092-00-14, Wisconsin Department of Transportation, Madison, WI.
- Kramer, S. L. 1996. *Geotechnical Earthquake Engineering*, Prentice-Hall, Upper Saddle River, NJ.
- Kulhawy, F. H. 1978. "Geomechanical Model for Rock Foundation Settlement," *Journal of the Geotechnical Engineering Division*. American Society of Civil Engineers, New York, NY, Vol. 104, No. GT2, pp. 211–227.
- Kulhawy, F. H., and R. E. Goodman. 1980. "Design of Foundations on Discontinuous Rock." In *Proc., International Conference on Structural Foundations on Rock*, International Society for Rock Mechanics, Vol. I, pp. 209–220.
- Kulhawy, F. H., and R. E. Goodman. 1987. "Foundations in Rock." In *Ground Engineering Reference Manual*, F. G. Bell, ed. Butterworths Publishing Co., London, Chapter 55.
- Kyfor, Z. G., A. R. Schnore, T. A. Carlo, and P. F. Bailey. 1992. *Static Testing of Deep Foundations*, FHWA-SA-91-042, Federal Highway Administration, Office of Technology Applications, U. S. Department of Transportation, Washington D. C., p. 174.

- Lam, I. P., and G. R. Martin. 1986. "Design Procedures and Guidelines." In *Seismic Design of Highway Bridge Foundations*, FHWA/RD-86/102, Federal Highway Administration, U.S. Department of Transportation, Washington, DC, Vol. 2, p. 18.
- Lambe, T.W. and R. V. Whitman. 1969. *Soil Mechanics*. New York, John Wiley and Sons, Inc.
- Lukas, R. G. 1995. *Geotechnical Engineering Circular No. 1—Dynamic Compaction*, FHWA-SA-95-037. Federal Highway Administration, U.S. Department of Transportation, Washington, DC.
- Mayne, P. W., B. R. Christopher, and J. DeJong. 2001. *Manual on Subsurface Investigations*, FHWA NHI-01-031. Federal Highway Administration, U.S. Department of Transportation, Washington, D.C.
- Meyerhof, G. G. 1953. "The Bearing Capacity of Foundations under Eccentric and Inclined Loads." In *Proc., 3rd International Conference on Soil Mechanics and Foundation Engineering*, Switzerland, pp. 440–445.
- Meyerhof, G. G. 1956. "Penetration Tests and Bearing Capacity of Cohesionless Soils," *Journal of the Soil Mechanics and Foundation Division*. American Society of Civil Engineers, Reston, VA, Vol. 82, No. SM1, pp. 866-1–866-19.
- Meyerhof, G. G. 1957. "The Ultimate Bearing Capacity of Foundations on Slopes." In *Proc., 4th International Conference on Soil Mechanics and Foundation Engineering*, London.
- Meyerhof, G.G. 1976. "Bearing Capacity and Settlement of Pile Foundations," *Journal of the Geotechnical Engineering Division*. American Society of Civil Engineers, New York, NY, Vol. 102, No. GT3, pp. 196–228.
- Morgano, C. M. and B. White. 2004. "Identifying Soil Relaxation from Dynamic Testing." In *Proc., 7th International Conference on the Application of Stresswave Theory to Piles 2004*, Petaling Jaya, Selangor, Malaysia.
- Moulton, L. K., H. V. S. GangaRao, and G. T. Halverson. 1985. *Tolerable Movement Criteria for Highway Bridges*, FHWA/RD-85/107. Federal Highway Administration, U.S. Department of Transportation, Washington, DC, p. 118.
- Moss, R. E. S., R. B. Seed, R. E. Kayen, J. P. Stewart, A. Der Kiureghian, and K. O. Cetin. 2006. "CPT-Based Probabilistic and Deterministic Assessment of In Situ Seismic Soil Liquefaction Potential," *Journal of Geotechnical and Geoenvironmental Engineering*. American Society of Civil Engineers, Reston, VA, Vol. 132, No. 8, pp. 1032–1051.
- Munfakh, G., A. Arman, J. G. Collin, J. C.-J. Hung, and R. P. Brouillette. 2001. *Shallow Foundations Reference Manual*, FHWA-NHI-01-023. Federal Highway Administration, U.S. Department of Transportation, Washington, DC.
- Nordlund, R. L. 1979. *Point Bearing and Shaft Friction of Piles in Sand*. Missouri-Rolla 5th Annual Short Course on the Fundamentals of Deep Foundation Design.
- Norris, G. M. 1986. "Theoretically Based BEF Laterally Loaded Pile Analysis." In *Proc., 3rd International Conference on Numerical Methods in Offshore Piling*, Nantes, France, pp. 361–386.
- Nottingham, L., and J. Schmertmann. 1975. *An Investigation of Pile Capacity Design Procedures*. Final Report D629 to Florida Department of Transportation from Department of Civil Engineering, University of Florida, Gainesville, FL, p. 159.
- Olson, S. M., and T. D. Stark. 2002. "Liquefied Strength Ratio from Liquefaction Flow Failure Case Histories," *Canadian Geotechnical Journal*. NRC Research Press, Ottawa, ON, Canada, Vol. 39, pp 629–647.
- O'Neill, M. W. and L. C. Reese. 1999. *Drilled Shafts: Construction Procedures and Design Methods*, FHWA-IF-99-025, Federal Highway Administration, U.S. Department of Transportation, Washington, DC.
- Paikowsky, S. G., C. Kuo, G. Baecher, B. Ayyub, K. Stenersen, K. O'Malley, L. Chernauskas, and M. O'Neill. 2004. *Load and Resistance Factor Design (LRFD) for Deep Foundations*, NCHRP Report 507. Transportation Research Board, National Research Council, Washington, DC.
- Peck, R. B., W. E. Hanson, and T. H. Thornburn. 1974. *Foundation Engineering*, Second Edition. John Wiley and Sons, Inc., New York, NY, p. 514.

- Potyondy, J. G. 1961. "Skin Friction Between Various Soils and Construction Materials," *Géotechnique*. Vol. 11, No. 4, pp. 339–353.
- Poulos, H. G., and E. H. Davis. 1974. *Elastic Solutions for Soil and Rock Mechanics*. John Wiley and Sons, Inc., New York, NY, p. 411.
- Prakash, S., and H. D. Sharma. 1990. *Pile Foundations in Engineering Practice*. John Wiley and Sons, Inc., New York, NY, p. 734.
- Prandtl, L. 1921. "Über die eindingungsfestigkeit (harte) plastischer baustoffe und die festigkeit von schneiden." *Zeitschrift für Angewandte Mathematik und Mechanik*, Vol. 1, No. 1, pp. 15–20.
- Rausche, F., F. Moses, and G. G. Goble. 1972. "Soil Resistance Predictions from Pile Dynamics," *Journal of the Soil Mechanics and Foundation Division*. American Society of Civil Engineers, Reston, VA, Vol. 98, No. SM9, pp. 917–937.
- Rausche, F., G. G. Goble, and G. Likins. 1985. "Dynamic Determination of Pile Capacity," *Journal of Geotechnical Engineering*. American Society of Civil Engineers, Reston, VA, Vol. 111, No. 3, pp. 367–383.
- Reese, L. C. 1984. *Handbook on Design of Piles and Drilled Shafts Under Lateral Load*, FHWA-IP-84/11. Federal Highway Administration, U.S. Department of Transportation, Washington, DC.
- Reese, L. C. 1986. *Behavior of Piles and Pile Groups Under Lateral Load*, FHWA/RD-85/106. Federal Highway Administration, Office of Engineering and Highway Operations Research and Development, U.S. Department of Transportation, Washington DC, p. 311.
- Reese, L. C., and M. W. O'Neill. 1988. *Drilled Shafts: Construction Procedures and Design Methods*, FHWA-HI-88-042 or ADSC-TL-4. Federal Highway Administration, U.S. Department of Transportation, Washington, DC, p. 564.
- Reissner, H. 1924. "Zum erddruckproblem." In *Proc., 1st Intem. Congress of Applied Mechanics*," Delft, Germany, pp. 295–311.
- Richardson, E. V., and S. R. Davis. 2001. *Hydraulic Engineering Circular 18, Evaluating Scour at Bridges*, Fourth Edition, FHWA NHI-01-001. Hydraulic Engineering Circular No. 18, Federal Highway Administration, U.S. Department of Transportation, Washington, DC.
- Sabatini, P. J, R. C Bachus, P. W. Mayne, J. A. Schneider, and T. E. Zettler. 2002. *Geotechnical Engineering Circular 5 (GEC5)—Evaluation of Soil and Rock Properties*, FHWA-IF-02-034. Federal Highway Administration, U.S. Department of Transportation, Washington, DC.
- Seed, R. B., and L. F. Harder. 1990. SPT-Based Analysis of Pore Pressure Generation and Undrained Residual Strength. In *Proc., H. B. Seed Memorial Symposium*, Berkeley, CA, May 1990. BiTech Ltd., Vancouver, BC, Canada, Vol. 2, pp. 351–376.
- Skempton, A. W. 1951. "The Bearing Capacity of Clays." In *Proc., Building Research Congress*, Vol. 1, pp. 180–189.
- Smith, S. P. 1994. "Preliminary Procedure to Predict Scour in Bedrock."
- Sowers, G. F. 1979. *Introductory Soil Mechanics and Foundations: Geotechnical Engineering*. MacMillan Publishing Co., New York, NY, p. 621.
- Terzaghi, K., and R. B. Peck. 1967. *Soil Mechanics in Engineering Practice*, Second Edition. John Wiley and Sons, Inc., New York, NY, p. 729.
- Terzaghi, K., R. G. Peck, and G. Mesri. 1996. *Soil Mechanics in Engineering Practice*. John Wiley and Sons, Inc., New York, NY, pp. 549.
- Tomlinson, M. J. 1980. *Foundation Design and Construction*, Fourth Edition. Pitman Publishing Limited, 128 Long Acre, London WC2E 9AN, UK.

- Tomlinson, M. J. 1986. *Foundation Design and Construction*, Fifth Edition. Longman Scientific and Technical, London, p. 842.
- Tomlinson, M. J. 1987. *Pile Design and Construction Practice*. Viewpoint Publication, p. 415.
- U.S. Department of the Navy. 1982. *Soil Mechanics. Design Manual 7.1*, NAVFAC DM-7.1. Naval Facilities Engineering Command, Alexandria, VA, p. 348.
- Vesic', A. S. 1970. *Research on Bearing Capacity of Soils*.
- Vesic', A. S. 1975. "Bearing Capacity of Shallow Foundations." In *Foundation Engineering Handbook*, H. Winterkorn, and H. Y. Fang, eds. Van Nostrand Reinhold Co., New York, NY, Chapter 3, pp. 121–147.
- Vesic', A. S. 1973. "Analysis of Ultimate Loads of Shallow Foundations," *Journal of the Soil Mechanics and Foundations Division*. American Society of Civil Engineers, Reston, VA, Vol. 99, No. SM1, pp. 45–73.
- Vijayvergiya, V. N., and J. A. Focht, Jr. 1972. "A New Way to Predict the Capacity of Piles in Clay." In *Proc., 4th Annual Offshore Technology Conference*, Vol. 2, pp. 865–874.
- Williams, M. E., M. McVay, and M. I. Hoit. 2003. "LRFD Substructure and Foundation Design Programs." In *Proc., 2003 International Bridge Conference*, June 9–11, Pittsburgh, PA.
- Winterkorn, H. F., and H. Y. Fang. 1975. *Foundation Engineering Handbook*. Van Nostrand Reinhold Company, New York, NY, p. 751.
- Wyllie, D. C. 1999. *Foundations on Rock*. Routledge, New York, NY.
- Yazdanbod, A., S. A. Sheikh, and M. W. O'Neill. 1987. "Uplift of Shallow Underream in Jointed Clay." In *Proc., Foundations for Transmission Line Towers*, J. L. Briaud, ed. American Society of Civil Engineers, Reston, VA, pp. 110–127.
- Youd, T. L., and I. M. Idriss. 1997. *Proc., NCEER Workshop on Evaluation of Liquefaction Resistance of Soils*, MCEER-97-0022.
- Youd, T. L. and B. L. Carter. 2005. "Influence of Soil Softening and Liquefaction on Spectral Acceleration," *Journal of Geotechnical and Geoenvironmental Engineering*. American Society of Civil Engineers, Reston, VA, Vol. 131, No. 7, pp. 811–825.
- Youd, et al. 2001. "Liquefaction Resistance of Soils: Summary Report from the 1996 NCEER and 1998 NCEER/NSF Workshops on Evaluation of Liquefaction Resistance in Soils," *Journal of Geotechnical and Geoenvironmental Engineering*. American Society of Civil Engineers, Reston, VA, Vol. 127, No. 10, pp. 817–833.
- Zhang, L. M., W. H. Tang, and C. W. W. Ng. 2001. "Reliability of Axially Loaded Driven Pile Groups," *Journal of Geotechnical and Geoenvironmental Engineering*. American Society of Civil Engineers, Reston, VA, Vol. 127, No. 12, pp. 1051–1060.

APPENDIX A10—SEISMIC ANALYSIS AND DESIGN OF FOUNDATIONS

A10.1—INVESTIGATION

Slope instability, liquefaction, fill settlement, and increases in lateral earth pressure have often been major factors contributing to bridge damage in earthquakes. These earthquake hazards may be significant design factors for peak earthquake accelerations in excess of 0.1 *g* and should form part of a site-specific investigation if the site conditions and the associated acceleration levels and design concepts suggest that such hazards may be of importance.

A10.2—FOUNDATION DESIGN

The commonly accepted practice for the seismic design of foundations is to utilize a pseudo-static approach, where earthquake-induced foundation loads are determined from the reaction forces and moments necessary for structural equilibrium. Although traditional bearing capacity design approaches are also applied, with appropriate capacity reduction factors if a margin of safety against “failure” is desired, a number of factors associated with the dynamic nature of earthquake loading should always be borne in mind.

Under cyclic loading at earthquake frequencies, the strength capable of being mobilized by many soils is greater than the static strength. For unsaturated cohesionless soils, the increase may be about ten percent, whereas for cohesive soils, a 50 percent increase could occur. However, for softer saturated clays and saturated sands, the potential for strength and stiffness degradation under repeated cycles of loading must also be recognized. For bridges classified as Zone 2, the use of static soil strengths for evaluating ultimate foundation capacity provides a small implicit measure of safety and, in most cases, strength and stiffness degradation under repeated loading will not be a problem because of the smaller magnitudes of seismic events. However, for bridges classified as Zones 3 and 4, some attention should be given to the potential for stiffness and strength degradation of site soils when evaluating ultimate foundation capacity for seismic design.

As earthquake loading is transient in nature, “failure” of soil for a short time during a cycle of loading may not be significant. Of perhaps greater concern is the magnitude of the cyclic foundation displacement or rotation associated with soil yield, as this could have a significant influence on structural displacements or bending moments and shear distributions in columns and other members.

As foundation compliance influences the distribution of forces or moments in a structure and affects computation of the natural period, equivalent stiffness factors for foundation systems are often required. In many cases, use is made of various analytical solutions that are available for footings or piles where it is assumed that soil behaves in an elastic medium. In using these formulae, it should be recognized that equivalent elastic moduli for soils are a function of strain amplitude, and for seismic loads modulus values could be significantly less than those appropriate for low levels of seismic loading. Variation of shear modulus with shearing strain amplitude in the case of sands is shown in Figure A10.2-1. Additional discussion of this topic can be found in the *AASHTO Guide Specifications for LRFD Seismic Design*.

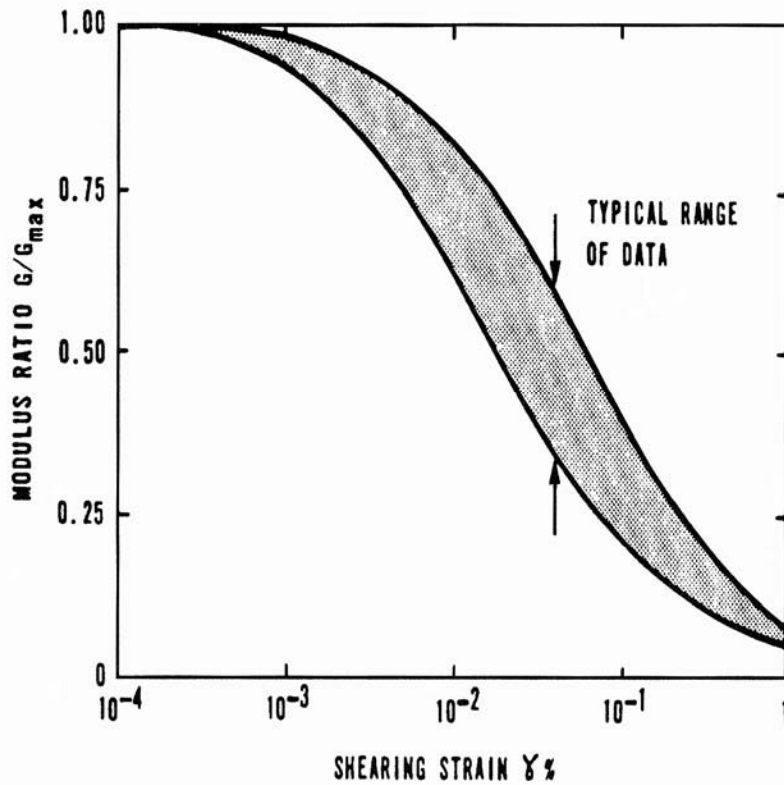

Figure A10.2-1—Variation of Shear Modulus with Shearing Strain for Sands

On the basis of field and experimental observations, it is becoming more widely recognized that transient foundation uplift or rocking during earthquake loading, resulting in separation of the foundation from the subsoil, is acceptable provided that appropriate design precautions are taken (Taylor and Williams, 1979). Experimental studies suggest that rotational yielding beneath rocking foundation can provide a useful form of energy dissipation. However, care must be taken to avoid significant induced vertical deformations accompanying possible soil yield during earthquake rocking as well as excessive pier movement. These could lead to design difficulties with relative displacements.

Lateral Loading of Piles—Most of the well-known solutions for computing the lateral stiffness of vertical piles are based on the assumption of elastic behavior and utilize equivalent cantilever beam concepts (Davisson and Gill, 1960), the beam on an elastic Inkler foundation method (Matlock and Reese, 1960), or elastic continuum solutions (Poulos, 1971). However, the use of methods incorporating nonlinear subgrade reaction behavior that allows for soil failure may be important for high lateral loading of piles in soft clay and sand. Such a procedure is encompassed in the American Petroleum Institute (API) recommendations for offshore platform design. The method utilizes nonlinear subgrade reaction or P - y curves for sands and clays that have been developed experimentally from field loading tests.

The general features of the API analysis in the case of sands are illustrated in Figure A10.2-2. Under large loads, a passive failure zone develops near the pile head. Test data indicate that the ultimate resistance, p_u , for lateral loading is reached for pile deflections, y_u , of about $3d/80$, where d is the pile diameter. Note that most of the lateral resistance is mobilized over a depth of about $5d$. The API method also recognizes degradation in lateral resistance with cyclic loading, although in the case of saturated sands, the degradation postulated does not reflect pore water pressure increases. The degradation in lateral resistance due to earthquake-induced, free-field pore water pressure increases in saturated sands has been described by Finn and Martin (1979). A numerical method that allows the use of API P - y curves to compute pile stiffness characteristics forms the basis of the computer program BMCOL 76 described by Bogard and Matlock (1977).

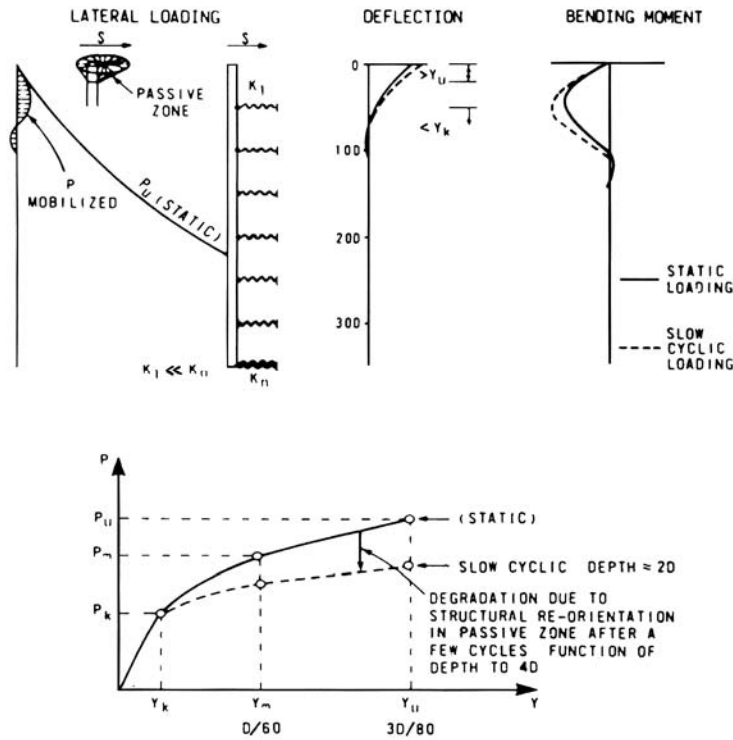

Figure A10.2-2—Lateral Loading of Piles in Sand Using API Criteria

The influence of group action on pile stiffness is a somewhat controversial subject. Solutions based on elastic theory can be misleading where yield near the pile head occurs. Experimental evidence tends to suggest that group action is not significant for pile spacings greater than $4d$ to $6d$.

For batter pile systems, the computation of lateral pile stiffness is complicated by the stiffness of the piles in axial compression and tension. It is also important to recognize that bending deformations in batter pile groups may generate high reaction forces on the pile cap.

It should be noted that although battered piles are economically attractive for resisting horizontal loads, such piles are very rigid in the lateral direction if arranged so that only axial loads are induced. Hence, large relative lateral displacements of the more flexible surrounding soil may occur during the free-field earthquake response of the site (particularly if large changes in soil stiffness occur over the pile length), and these relative displacements may in turn induce high pile bending moments. For this reason, more flexible vertical pipe systems where lateral load is resisted by bending near the pile heads are recommended. However, such pile systems must be designed to be ductile because large lateral displacements may be necessary to resist the lateral load. A compromise design using battered piles spaced some distance apart may provide a system that has the benefits of limited flexibility and the economy of axial load resistance to lateral load.

Soil-Pile Interaction—The use of pile stiffness characteristics to determine earthquake-induced pile bending moments based on a pseudo-static approach assumes that moments are induced only by lateral loads arising from inertial effects on the bridge structure. However, it must be remembered that the inertial loads are generated by interaction of the free-field earthquake ground motion with the piles and that the free-field displacements themselves can influence bending moments. This is illustrated in an idealized manner in Figure A10.2-3. The free-field earthquake displacement time histories provide input into the lateral resistance interface elements, which in turn transfer motion to the pile. Near the pile heads, bending moments will be dominated by the lateral interaction loads generated by inertial effects on the bridge structure. At greater depth (e.g., greater than $10d$), where soil stiffness progressively increases with respect to pile stiffness, the pile will be constrained to deform in a manner similar to that of the free field, and pile bending moments become a function of the curvatures induced by free-field displacements.

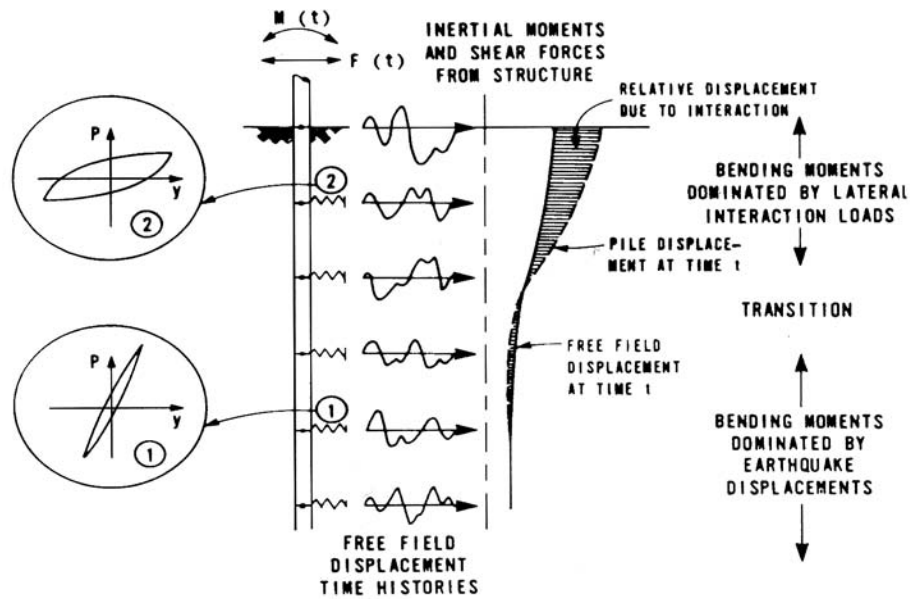

Figure A10.2-3—Mechanism of Soil-Pile Interaction during Seismic Loading

To illustrate the nature of free-field displacements, reference is made to Figure A10.2-4, which represents a 200-ft deep cohesionless soil profile subjected to the El Centro earthquake. The free-field response was determined using a nonlinear, one-dimensional response analysis. From the displacement profiles shown at specific times, curvatures can be computed and pile bending moments calculated if it is assumed that the pile is constrained to displace in phase with the free-field response.

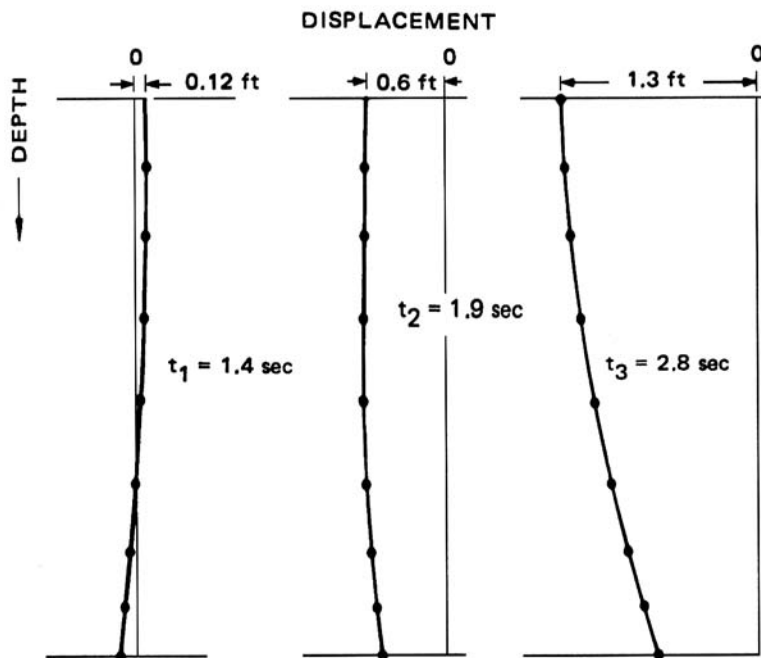

Figure A10.2-4—Typical Earthquake Displacement Profiles

Large curvatures could develop at interfaces between soft and rigid soils and, clearly, in such cases emphasis should be placed on using flexible ductile piles. Margason (1979) suggests that curvatures of up to 6×10^{-4} in.⁻¹ could be induced by strong earthquakes, but these should pose no problem to well-designed steel or prestressed concrete piles.

Studies incorporating the complete soil-pile structure interaction system, as presented in Figure A10.2-3, have been described by Penzien (1970) for a bridge piling system in a deep soft clay. A similar but somewhat simpler soil-pile structure interaction system (SPASM) to that used by Penzien has been described by Matlock et al. (1978). The model used is, in effect, a dynamic version of the previously mentioned BMCOL program.

A10.3—SPECIAL PILE REQUIREMENTS

The uncertainties of ground and bridge response characteristics lead to the desirability of providing tolerant pile and foundation systems. Toughness under induced curvature and shears is required, and hence piles such as steel H-sections and concrete filled steel-cased piles are favored for highly seismic areas. Unreinforced concrete piles are brittle in nature, so nominal longitudinal reinforcing is specified to reduce this hazard. The reinforcing steel should be extended into the footing to tie elements together and to assist in load transfer from the pile to the pile cap.

Experience has shown that reinforced concrete piles tend to hinge or shatter immediately below the pile cap. Hence, tie spacing is reduced in this area so that the concrete is better confined. Driven precast piles should be constructed with considerable spiral confining steel to ensure good shear strength and tolerance of yield curvatures should these be imparted by the soil or structural response. Clearly, it is desirable to ensure that piles do not fail below ground level and that flexural yielding in the columns is forced to occur above ground level. The additional pile design requirements imposed on piles for bridges classified as Zones 3 and 4, for which earthquake loading is more severe, reflect a design philosophy aimed at minimizing below-ground damage that is not easily inspected following a major earthquake.

SECTION 11: WALLS, ABUTMENTS, AND PIERS

TABLE OF CONTENTS

11.1—SCOPE 11-1

11.2—DEFINITIONS..... 11-1

11.3—NOTATION..... 11-2

 11.3.1—General..... 11-2

11.4—SOIL PROPERTIES AND MATERIALS 11-5

 11.4.1—General..... 11-5

 11.4.2—Determination of Soil Properties..... 11-5

11.5—LIMIT STATES AND RESISTANCE FACTORS 11-6

 11.5.1—General..... 11-6

 11.5.2—Service Limit States 11-6

 11.5.3—Strength Limit State 11-7

 11.5.4—Extreme Event Limit State..... 11-7

 11.5.4.1—General Requirements 11-7

 11.5.4.2—Extreme Event I, No Analysis 11-8

 11.5.5—Resistance Requirement..... 11-10

 11.5.6—Load Combinations and Load Factors 11-10

 11.5.7—Resistance Factors—Service and Strength..... 11-13

 11.5.8—Resistance Factors—Extreme Event Limit State 11-16

11.6—ABUTMENTS AND CONVENTIONAL RETAINING WALLS 11-16

 11.6.1—General Considerations 11-16

 11.6.1.1—General..... 11-16

 11.6.1.2—Loading..... 11-17

 11.6.1.3—Integral Abutments 11-18

 11.6.1.4—Wingwalls 11-18

 11.6.1.5—Reinforcement 11-18

 11.6.1.5.1—Conventional Walls and Abutments 11-18

 11.6.1.5.2—Wingwalls..... 11-18

 11.6.1.6—Expansion and Contraction Joints..... 11-18

 11.6.2—Movement and Stability at the Service Limit State..... 11-19

 11.6.2.1—Abutments..... 11-19

 11.6.2.2—Conventional Retaining Walls 11-19

 11.6.2.3—Overall Stability..... 11-19

 11.6.3—Bearing Resistance and Stability at the Strength Limit State..... 11-20

 11.6.3.1—General..... 11-20

 11.6.3.2—Bearing Resistance..... 11-20

 11.6.3.3—Eccentricity Limits..... 11-22

 11.6.3.4—Subsurface Erosion 11-22

 11.6.3.5—Passive Resistance 11-23

 11.6.3.6—Sliding..... 11-23

 11.6.4—Safety against Structural Failure 11-23

 11.6.5—Seismic Design for Abutments and Conventional Retaining Walls..... 11-23

 11.6.5.1—General..... 11-23

 11.6.5.2—Calculation of Seismic Acceleration Coefficients for Wall Design..... 11-26

 11.6.5.2.1—Characterization of Acceleration at Wall Base..... 11-26

 11.6.5.2.2—Estimation of Acceleration Acting on Wall Mass 11-26

11.6.5.3—Calculation of Seismic Active Earth Pressures	11-27
11.6.5.4—Calculation of Seismic Earth Pressure for Nonyielding Abutments and Walls	11-30
11.6.5.5—Calculation of Seismic Passive Earth Pressure	11-31
11.6.5.6—Wall Details for Improved Seismic Performance.....	11-32
11.6.6—Drainage.....	11-33
11.7—PIERS.....	11-33
11.7.1—Load Effects in Piers	11-33
11.7.2—Pier Protection.....	11-34
11.7.2.1—Collision.....	11-34
11.7.2.2—Collision Walls.....	11-34
11.7.2.3—Scour.....	11-34
11.7.2.4—Facing.....	11-34
11.8—NONGRAVITY CANTILEVERED WALLS	11-34
11.8.1—General.....	11-34
11.8.2—Loading.....	11-34
11.8.3—Movement and Stability at the Service Limit State.....	11-34
11.8.3.1—Movement.....	11-34
11.8.3.2—Overall Stability.....	11-35
11.8.4—Safety against Soil Failure at the Strength Limit State.....	11-35
11.8.4.1—Overall Stability.....	11-35
11.8.5—Safety against Structural Failure.....	11-36
11.8.5.1—Vertical Wall Elements.....	11-36
11.8.5.2—Facing.....	11-36
11.8.6—Seismic Design of Nongravity Cantilever Walls.....	11-38
11.8.6.1—General.....	11-38
11.8.6.2—Seismic Active Lateral Earth Pressure.....	11-38
11.8.6.3—Seismic Passive Lateral Earth Pressure.....	11-40
11.8.6.4—Wall Displacement Analyses to Determine Earth Pressures.....	11-41
11.8.7—Corrosion Protection	11-42
11.8.8—Drainage.....	11-43
11.9—ANCHORED WALLS.....	11-43
11.9.1—General.....	11-43
11.9.2—Loading.....	11-44
11.9.3—Movement and Stability at the Service Limit State.....	11-44
11.9.3.1—Movement.....	11-44
11.9.3.2—Overall Stability.....	11-45
11.9.4—Safety against Soil Failure.....	11-45
11.9.4.1—Bearing Resistance.....	11-45
11.9.4.2—Anchor Pullout Capacity.....	11-46
11.9.4.3—Passive Resistance.....	11-49
11.9.5—Safety against Structural Failure.....	11-49
11.9.5.1—Anchors.....	11-49
11.9.5.2—Vertical Wall Elements.....	11-51
11.9.5.3—Facing.....	11-51
11.9.6—Seismic Design.....	11-51
11.9.7—Corrosion Protection	11-52

11.9.8—Construction and Installation	11-53
11.9.8.1—Anchor Stressing and Testing	11-53
11.9.9—Drainage	11-54
11.10—MECHANICALLY STABILIZED EARTH WALLS	11-54
11.10.1—General	11-54
11.10.2—Structure Dimensions	11-56
11.10.2.1—Minimum Length of Soil Reinforcement	11-57
11.10.2.2—Minimum Front Face Embedment	11-58
11.10.2.3—Facing	11-58
11.10.2.3.1—Stiff or Rigid Concrete, Steel, and Timber Facings	11-59
11.10.2.3.2—Flexible Wall Facings	11-59
11.10.2.3.3—Corrosion Issues for MSE Facing	11-60
11.10.3—Loading	11-60
11.10.4—Movement and Stability at the Service Limit State	11-60
11.10.4.1—Settlement	11-60
11.10.4.2—Lateral Displacement	11-61
11.10.4.3—Overall Stability	11-61
11.10.5—Safety against Soil Failure (External Stability)	11-62
11.10.5.1—General	11-62
11.10.5.2—Loading	11-63
11.10.5.3—Sliding	11-64
11.10.5.4—Bearing Resistance	11-64
11.10.5.5—Overturning	11-64
11.10.6—Safety against Structural Failure (Internal Stability)	11-65
11.10.6.1—General	11-65
11.10.6.2—Loading	11-65
11.10.6.2.1—Maximum Reinforcement Loads	11-66
11.10.6.2.2—Reinforcement Loads at Connection to Wall Face	11-70
11.10.6.3—Reinforcement Pullout	11-70
11.10.6.3.1—Boundary between Active and Resistant Zones	11-70
11.10.6.3.2—Reinforcement Pullout Design	11-72
11.10.6.4—Reinforcement Strength	11-74
11.10.6.4.1—General	11-74
11.10.6.4.2—Design Life Considerations	11-76
11.10.6.4.2a—Steel Reinforcements	11-76
11.10.6.4.2b—Geosynthetic Reinforcements	11-78
11.10.6.4.3—Design Tensile Resistance	11-80
11.10.6.4.3a—Steel Reinforcements	11-80
11.10.6.4.3b—Geosynthetic Reinforcements	11-80
11.10.6.4.4—Reinforcement/Facing Connection Design Strength	11-82
11.10.6.4.4a—Steel Reinforcements	11-82
11.10.6.4.4b—Geosynthetic Reinforcements	11-82
11.10.7—Seismic Design of MSE Walls	11-86
11.10.7.1—External Stability	11-86
11.10.7.2—Internal Stability	11-87
11.10.7.3—Facing Reinforcement Connections	11-91
11.10.7.4—Wall Details for Improved Seismic Performance	11-93

11.10.8—Drainage	11-94
11.10.9—Subsurface Erosion.....	11-94
11.10.10—Special Loading Conditions	11-95
11.10.10.1—Concentrated Dead Loads	11-95
11.10.10.2—Traffic Loads and Barriers	11-96
11.10.10.3—Hydrostatic Pressures	11-98
11.10.10.4—Obstructions in the Reinforced Soil Zone	11-98
11.10.11—MSE Abutments	11-99
11.11—PREFABRICATED MODULAR WALLS	11-101
11.11.1—General	11-101
11.11.2—Loading	11-102
11.11.3—Movement at the Service Limit State	11-102
11.11.4—Safety against Soil Failure.....	11-102
11.11.4.1—General	11-102
11.11.4.2—Sliding	11-102
11.11.4.3—Bearing Resistance	11-102
11.11.4.4—Overturning	11-103
11.11.4.5—Subsurface Erosion	11-103
11.11.4.6—Overall Stability	11-103
11.11.4.7—Passive Resistance and Sliding	11-103
11.11.5—Safety against Structural Failure	11-103
11.11.5.1—Module Members	11-103
11.11.6—Seismic Design for Prefabricated Modular Walls	11-104
11.11.7—Abutments	11-105
11.11.8—Drainage	11-105
11.12—REFERENCES	11-105
APPENDIX A11—SEISMIC DESIGN OF RETAINING STRUCTURES	11-109
A11.1—GENERAL	11-109
A11.2—PERFORMANCE OF WALLS IN PAST EARTHQUAKES.....	11-109
A11.3—CALCULATION OF SEISMIC ACTIVE PRESSURE.....	11-110
A11.3.1—Mononobe-Okabe Method	11-110
A11.3.2—Modification of Mononobe-Okabe Method to Consider Cohesion	11-112
A11.3.3—Generalized Limit Equilibrium (GLE) Method.....	11-115
A11.4—SEISMIC PASSIVE PRESSURE	11-115
A11.5—ESTIMATING WALL SEISMIC ACCELERATION CONSIDERING WAVE SCATTERING AND WALL DISPLACEMENT	11-120
A11.5.1—Kavazanjian et al., (1997).....	11-121
A11.5.2—NCHRP Report 611—Anderson et al. (2008).....	11-121
A11.5.3—Bray et al. (2010), and Bray and Travasarou (2009)	11-124
A11.6—APPENDIX REFERENCES	11-124

SECTION 11

WALLS, ABUTMENTS, AND PIERS

11.1—SCOPE

This Section provides requirements for design of abutments and walls. Conventional retaining walls, nongravity cantilevered walls, anchored walls, mechanically stabilized earth (MSE) walls, and prefabricated modular walls are considered.

11.2—DEFINITIONS

Abutment—A structure that supports the end of a bridge span, and provides lateral support for fill material on which the roadway rests immediately adjacent to the bridge. In practice, different types of abutments may be used. These include:

- *Stub Abutment*—Stub abutments are located at or near the top of approach fills, with a backwall depth sufficient to accommodate the structure depth and bearings which sit on the bearing seat.
- *Partial-Depth Abutment*—Partial-depth abutments are located approximately at middepth of the front slope of the approach embankment. The higher backwall and wingwalls may retain fill material, or the embankment slope may continue behind the backwall. In the latter case, a structural approach slab or end span design must bridge the space over the fill slope, and curtain walls are provided to close off the open area. Inspection access should be provided for this situation.
- *Full-Depth Abutment*—Full-depth abutments are located at the approximate front toe of the approach embankment, restricting the opening under the structure.
- *Integral Abutment*—Integral abutments are rigidly attached to the superstructure and are supported on a spread or deep foundations capable of permitting necessary horizontal movements.

Anchored Wall—An earth retaining system typically composed of the same elements as nongravity cantilevered walls, and that derive additional lateral resistance from one or more tiers of anchors.

Mechanically Stabilized Earth Wall—A soil-retaining system, employing either strip or grid-type, metallic, or polymeric tensile reinforcements in the soil mass, and a facing element that is either vertical or nearly vertical.

Nongravity Cantilever Wall—A soil-retaining system that derives lateral resistance through embedment of vertical wall elements and supports retained soil with facing elements. Vertical wall elements may consist of discrete elements, e.g., piles, drilled shafts or auger-cast piles spanned by a structural facing, e.g., lagging, panels or shotcrete. Alternatively, the vertical wall elements and facing may be continuous, e.g., sheet piles, diaphragm wall panels, tangent-piles, or tangent drilled shafts.

Pier—That part of a bridge structure that provides intermediate support to the superstructure. Different types of piers may be used. These include:

- *Solid Wall Piers*—Solid wall piers are designed as columns for forces and moments acting about the weak axis and as piers for those acting about the strong axis. They may be pinned, fixed or free at the top, and are conventionally fixed at the base. Short, stubby types are often pinned at the base to eliminate the high moments which would develop due to fixity. Earlier, more massive designs were considered gravity types.
- *Double Wall Piers*—Double wall piers consist of two separate walls, spaced in the direction of traffic, to provide support at the continuous soffit of concrete box superstructure sections. These walls are integral with the superstructure and must also be designed for the superstructure moments which develop from live loads and erection conditions.

- *Bent Piers*—Bent-type piers consist of two or more transversely spaced columns of various solid cross-sections, and these types are designed for frame action relative to forces acting about the strong axis of the pier. They are usually fixed at the base of the pier and are either integral with the superstructure or with a pier cap at the top. The columns may be supported on a spread- or pile-supported footing, or a solid wall shaft, or they may be extensions of the piles or shaft above the ground line.
- *Single-Column Piers*—Single-column piers, often referred to as “T” or “Hammerhead” piers, are usually supported at the base by a spread-, drilled shaft- or pile-supported footing, and may be either integral with, or provide independent support for, the superstructure. Their cross-section can be of various shapes and the column can be prismatic or flared to form the pier cap or to blend with the sectional configuration of the superstructure cross-section. This type of pier can avoid the complexities of skewed supports if integrally framed into the superstructure and their appearance reduces the massiveness often associated with superstructures.
- *Tubular Piers*—A hollow core section which may be of steel, reinforced concrete or prestressed concrete, of such cross-section to support the forces and moments acting on the elements. Because of their vulnerability to lateral loadings, tubular piers shall be of sufficient wall thickness to sustain the forces and moments for all loading situations as are appropriate. Prismatic configurations may be sectionally precast or prestressed as erected.

Prefabricated Modular Wall—A soil-retaining system employing interlocking soil-filled timber, reinforced concrete, or steel modules or bins to resist earth pressures by acting as gravity retaining walls.

Rigid Gravity and Semi-Gravity (Conventional) Retaining Wall—A structure that provides lateral support for a mass of soil and that owes its stability primarily to its own weight and to the weight of any soil located directly above its base.

In practice, different types of rigid gravity and semi-gravity retaining walls may be used. These include:

- A *gravity* wall depends entirely on the weight of the stone or concrete masonry and of any soil resting on the masonry for its stability. Only a nominal amount of steel is placed near the exposed faces to prevent surface cracking due to temperature changes.
- A *semi-gravity* wall is somewhat more slender than a gravity wall and requires reinforcement consisting of vertical bars along the inner face and dowels continuing into the footing. It is provided with temperature steel near the exposed face.
- A *cantilever* wall consists of a concrete stem and a concrete base slab, both of which are relatively thin and fully reinforced to resist the moments and shears to which they are subjected.
- A *counterfort* wall consists of a thin concrete face slab, usually vertical, supported at intervals on the inner side by vertical slabs or counterforts that meet the face slab at right angles. Both the face slab and the counterforts are connected to a base slab, and the space above the base slab and between the counterforts is backfilled with soil. All the slabs are fully reinforced.

11.3—NOTATION

11.3.1—General

A_c	=	cross-sectional area of reinforcement unit (in. ²) (11.10.6.4.1)
A_S	=	peak seismic ground acceleration coefficient modified by short-period site factor (11.6.5) (C11.8.6) (11.10.7.1)
B	=	wall base width (ft) (11.10.2)
b	=	unit width of reinforcement; width of bin module (ft) (11.10.6.4.1) (11.11.5.1)
b_f	=	width of applied footing load (ft) (11.10.10.2)
C	=	overall reinforcement surface area geometry factor (dim.) (11.10.6.3.2)
CR_{cr}	=	long-term connection strength reduction factor to account for reduced ultimate strength resulting from connection (dim.) (11.10.6.4.4b)

CR_u	=	short-term connection strength reduction factor to account for reduced ultimate strength resulting from the connection (dim.) (11.10.6.4.4b)
C_u	=	coefficient of uniformity defined as ratio of the particle size of soil that is 60 percent finer in size (D_{60}) to the particle size of soil that is ten percent finer in size (D_{10}) (dim.) (11.10.6.3.2)
D	=	design embedment depth of vertical element (ft); diameter of bar or wire (in.) (11.10.6.3.2) (C11.8.4.1)
D^*	=	diameter of bar or wire corrected for corrosion loss (ft) (11.10.6.4.1)
D_o	=	embedment for which net passive pressure is sufficient to provide moment equilibrium (ft) (C11.8.4.1)
d	=	diameter of anchor drill hole (ft); the lateral wall displacement (in.); fill above wall (ft) (C11.6.5) (11.9.4.2) (11.10.8)
E_c	=	thickness of metal reinforcement at end of service life (mil.) (11.10.6.4.1)
E_n	=	nominal thickness of steel reinforcement at construction (mil.) (11.10.6.4.2a)
E_s	=	sacrificial thickness of metal expected to be lost by uniform corrosion during service life (mil.) (11.10.6.4.2a)
e	=	eccentricity of load from centerline of foundation (ft) (11.10.8)
F_p	=	static lateral force due to a concentrated surcharge load (kips/ft) (11.6.5.1)
F_T	=	resultant force of active lateral earth pressure (kips/ft) (11.6.3.2)
F_v	=	site class adjustment factor for the 1-sec. spectral acceleration (dim.) (A11.5)
F_y	=	minimum yield strength of steel (ksi) (11.10.6.4.3a)
F^*	=	reinforcement pullout friction factor (dim.) (11.10.6.3.2)
G_u	=	distance from center of gravity of a horizontal segmental facing block unit, including aggregate fill, measured from the front of the unit (ft) (11.10.6.4.4b)
H	=	height of wall (ft) (11.6.5.1)
H_h	=	hinge height for segmental facing (ft) (11.10.6.4.4b)
H_u	=	segmental facing block unit height (ft) (11.10.6.4.4b)
H_1	=	equivalent wall height (ft) (11.10.6.3.1)
h	=	vertical distance between ground surface and wall base at the back of wall heel (ft) (11.6.3.2) (11.10.7.1)
h_a	=	distance between the base of the wall, or the mudline in front of the wall, and the resultant active seismic earth pressure force (ft) (A11.3.1)
h_i	=	height of reinforced soil zone contributing horizontal load to reinforcement at level i (ft) (11.10.6.2.1)
h_p	=	vertical distance between the wall base and the static surcharge lateral force F_p (ft) (11.6.5.1)
i	=	backfill slope angle (degrees) (A11.3.1)
i_b	=	slope of facing base downward into backfill (degrees) (11.10.6.4.4b)
K	=	seismic passive pressure coefficient (dim.) (A11.3.1)
K_{AE}	=	seismic active pressure coefficient (dim.) (A11.3.1)
k_a	=	active earth pressure coefficient (dim.) (11.8.4.1)
k_{af}	=	active earth pressure coefficient of backfill (dim.) (11.10.5.2)
k_h	=	horizontal seismic acceleration coefficient (dim.) (11.8.6)
k_{h0}	=	horizontal seismic acceleration coefficient at zero displacement (dim.) (11.6.5.2)
k_v	=	vertical seismic acceleration coefficient (dim.) (11.6.5.3)
k_r	=	horizontal earth pressure coefficient of reinforced fill (dim.) (11.10.5.2)
k_y	=	yield acceleration in sliding block analysis that results in sliding of the wall (dim) (A11.5)
L	=	spacing between vertical elements or facing supports (ft); length of reinforcing elements in an MSE wall and correspondingly its foundation (ft) (11.8.5.2) (11.10.2)
L_a	=	length of reinforcement in active zone (ft) (11.10.2)
L_b	=	anchor bond length (ft) (11.9.4.2)
L_e	=	length of reinforcement in resistance zone (ft) (11.10.2)
L_{ei}	=	effective reinforcement length for layer i (ft) (11.10.7.2)
M	=	moment magnitude of design earthquake (dim.) (A11.5)
$MARV$	=	minimum average roll value (11.10.6.4.3b)
M_{max}	=	maximum bending moment in vertical wall element or facing (kip-ft or kip-ft/ft) (11.8.5.2)
N	=	normal component of resultant on base of foundation or standard penetration resistance from SPT (kips/ft or blows/ft, respectively) (11.6.3.2) (A11.5)
n	=	total number of reinforcement layers in the wall (dim) (11.10.7.2)
P_{AE}	=	dynamic active horizontal thrust, including static earth pressure (kips/ft) (11.10.7.1)
P_a	=	resultant active earth pressure force per unit width of wall (kips/ft) (11.8.6.2)
P_b	=	pressure inside bin module (ksf) (11.10.5.1)
PGA	=	peak ground acceleration (dim.) (11.6.5.1)
P_H	=	lateral force due to superstructure or other concentrated loads (kips/ft) (11.10.10.1)

P_i	=	factored horizontal force per mm of wall transferred to soil reinforcement at level i ; internal inertial force, due to the weight of the backfill within the active zone (kips/ft) (11.10.6.2.1) (11.10.7.2)
P_{IR}	=	horizontal inertial force (kips/ft) (11.10.7.1)
P_{ir}	=	horizontal inertial force caused by acceleration of reinforced backfill (kips/ft) (11.10.7.1)
P_{is}	=	internal inertial force caused by acceleration of sloping surcharge (kips/ft) (11.10.7.1)
P_{PE}	=	dynamic passive horizontal thrust, including static earth pressure (kips/ft) (11.8.6.2)
P_r	=	ultimate soil reinforcement pullout resistance per unit of reinforcement width (kips/ft) (11.10.6.3.2)
P_{seis}	=	total lateral force applied to a wall during seismic loading (kips/ft) (11.6.5.1)
P_v	=	load on strip footing (kips/ft) (11.10.10.1)
P'_v	=	load on isolated rectangular footing or point load (kips) (11.10.10.1)
PVG	=	peak ground velocity (in./sec.) (A11.5)
p	=	average lateral pressure, including earth, surcharge and water pressure, acting on the section of wall element being considered (ksf) (11.9.5.2)
Q_n	=	nominal (ultimate) anchor resistance (kips) (11.9.4.2)
Q_R	=	factored anchor resistance (kips) (11.9.4.2)
q_s	=	surcharge pressure (ksf) (11.10.5.2)
q_{max}	=	maximum unit soil pressure on base of foundation (ksf) (11.6.3.2)
R	=	resultant force at base of wall (kips/ft) (11.6.3.2)
R_{BH}	=	basal heave ratio (C11.9.3.1)
R_c	=	reinforcement coverage ratio (dim.) (11.10.6.3.2)
R_n	=	nominal resistance (kips or kips/ft) (11.5.4)
R_R	=	factored resistance (kips or kips/ft) (11.5.4)
RF	=	combined strength reduction factor to account for potential long-term degradation due to installation damage, creep and chemical/biological aging of geosynthetic reinforcements (dim.) (11.10.6.4.2b)
RF_c	=	combined strength reduction factor for long-term degradation of geosynthetic reinforcement facing connection (dim.) (11.10.6.4.4b)
RF_{CR}	=	strength reduction factor to prevent long-term creep rupture of reinforcement (dim.) (11.10.6.4.3b)
RF_D	=	strength reduction factor to prevent rupture of reinforcement due to chemical and biological degradation (dim.) (11.10.6.4.3b)
RF_{ID}	=	strength reduction factor to account for installation damage to reinforcement (dim.) (11.10.6.4.3b)
S_h	=	horizontal reinforcement spacing (ft) (11.10.6.4.1)
S_t	=	spacing between transverse grid elements (in.) (11.10.6.3.2)
S_u	=	undrained shear strength (ksf) (11.9.5.2)
S_v	=	vertical spacing of reinforcements (ft) (11.10.6.2.1)
S_{rs}	=	ultimate reinforcement tensile resistance required to resist static load component (kips/ft) (11.10.7.2)
S_{rt}	=	ultimate reinforcement tensile resistance required to resist transient load component (kips/ft) (11.10.7.2)
S_1	=	1-sec. spectral acceleration coefficient (dim.) (A11.5)
T_{ac}	=	nominal long-term reinforcement/facing connection design strength (kips/ft) (11.10.6.4.1)
T_{at}	=	nominal long-term reinforcement design strength (kips/ft) (11.10.6.4.1)
T_{crc}	=	creep reduced connection strength per unit of reinforcement width determined from the stress rupture envelope at the specified design life as produced from a series of long-term connection creep tests (kips/ft) (11.10.6.4.4b)
T_{lot}	=	ultimate wide width tensile strength per unit of reinforcement width (ASTM D4595 or D6637) for the reinforcement material lot used for the connection strength testing (kips/ft) (11.10.6.4.4b)
T_{md}	=	factored incremental dynamic inertia force (kips/ft) (11.10.7.2)
$T_{ultconn}$	=	ultimate connection strength per unit of reinforcement width (kips/ft) (11.10.6.4.4b)
T_{ult}	=	ultimate tensile strength of reinforcement (kips/ft) (11.10.6.4.3b)
T_{max}	=	applied load to reinforcement (kips/ft) (11.10.6.2.1)
T_o	=	factored tensile load at reinforcement/facing connection (kips/ft) (11.10.6.2.2)
t	=	thickness of transverse elements (in.) (11.10.6.3.2)
T_s	=	fundamental period of wall (sec.) (A11.5)
T_{total}	=	total load on reinforcement layer (static & dynamic) per unit width of wall (kips/ft) (11.10.7.2)
V_s	=	shear wave velocity of soil behind wall (ft/sec.) (A11.5)
V_1	=	weight of soil carried by wall heel, not including weight of soil surcharge (kips/ft) (11.6.3.2)
V_2	=	weight of soil surcharge directly above wall heel (kips/ft) (11.6.3.2)
W_s	=	weight of the soil that is immediately above the wall, including the wall heel (kips/ft) (11.6.5.1)
W_u	=	unit width of segmental facing (ft) (11.10.2.3.2)
W_w	=	weight of the wall (kips/ft) (11.6.5.1)
W_1	=	weight of wall stem (kips/ft) (11.6.3.2)

W_2	=	weight of wall footing or base (kips/ft) (11.6.3.2)
x	=	spacing between vertical element supports (ft) (11.9.5.2)
Z	=	depth below effective top of wall or to reinforcement (ft) (11.10.6.2.1)
Z_p	=	depth of soil at reinforcement layer at beginning of resistance zone for pullout calculation (ft) (11.10.6.2.1)
α	=	scale effect correction factor, or wall height acceleration reduction factor for wave scattering (dim.) (11.10.6.3.2) (A11.5)
β	=	inclination of ground slope behind face of wall (degrees) (11.5.5)
γ_{EQ}	=	load factor for live load applied simultaneously with seismic loads in Article 3.4.1 (dim.) (11.6.5)
γ_P	=	load factor for vertical earth pressure in Article 3.4.1 (dim.) (11.10.6.2.1)
γ_s	=	soil unit weight (kcf)
γ'_s	=	effective soil unit weight (kcf) (C11.8.4.1)
γ_r	=	unit weight of reinforced fill (kcf) (11.10.5.2)
γ_f	=	unit weight of backfill (kcf) (11.10.5.2)
$\Delta\sigma_H$	=	horizontal stress on reinforcement from concentrated horizontal surcharge (ksf); traffic barrier impact stress applied over reinforcement tributary area (ksf) (11.10.6.2.1) (11.10.10.2)
$\Delta\sigma_v$	=	vertical stress due to footing load (ksf) (11.10.8)
δ	=	wall-backfill interface friction angle (degrees) (11.5.5)
δ_{max}	=	maximum displacement (ft) (11.10.4.2)
δ_R	=	relative displacement coefficient (11.10.4.2)
θ	=	wall batter from horizontal (degrees) (11.10.6.2.1)
θ_{MO}	=	arc tan [$k_h/(1-k_v)$] for M-O analysis (degrees) (11.6.5.3)
ρ	=	soil-reinforcement angle of friction (degrees) (11.10.5.3)
ϕ	=	resistance factor (11.5.4)
ϕ_f	=	internal friction angle of foundation or backfill soil (degrees) (11.10.2)
ϕ_r	=	internal friction angle of reinforced fill (degrees) (11.10.5.2)
ϕ'_f	=	effective internal friction angle of soil (degrees) (11.8.4.1)
σ_H	=	factored horizontal stress at reinforcement level (ksf) (11.10.6.2.1)
σ_{Hmax}	=	maximum stress in soil reinforcement in abutment zones (11.10.8)
σ_v	=	vertical stress in soil (ksf) (11.10.6.2.1)
σ_{Vl}	=	vertical soil stress over effective base width (ksf) (11.10.8)
τ_n	=	nominal anchor bond stress (ksf) (11.9.4.2)
ω	=	wall batter due to setback of segmental facing units (degrees) (11.10.6.4.4b)

11.4—SOIL PROPERTIES AND MATERIALS

11.4.1—General

Backfill materials should be granular, free-draining materials. Where walls retain in-situ cohesive soils, drainage shall be provided to reduce hydrostatic water pressure behind the wall.

C11.4.1

Much of the knowledge and experience with MSE structures has been with select, cohesionless backfill as specified in Section 7 of AASHTO LRFD Bridge Construction Specifications. Hence, knowledge about internal stress distribution, pullout resistance and failure surface shape is constrained and influenced by the unique engineering properties of granular soils. While cohesive soils have been successfully used, problems including excessive deformation and complete collapse have also occurred. Most of these problems have been attributed to poor drainage. Drainage requirements for walls constructed with poor draining soils are provided in Berg et al. (2009).

11.4.2—Determination of Soil Properties

The provisions of Articles 2.4 and 10.4 shall apply.

11.5—LIMIT STATES AND RESISTANCE FACTORS

11.5.1—General

Design of abutments, piers and walls shall satisfy the criteria for the service limit state specified in Article 11.5.2, and for the strength limit state specified in Article 11.5.3.

Abutments, piers and retaining walls shall be designed to withstand lateral earth and water pressures, including any live and dead load surcharge, the self weight of the wall, temperature and shrinkage effects, and earthquake loads in accordance with the general principles specified in this Section.

Earth retaining structures shall be designed for a service life based on consideration of the potential long-term effects of material deterioration, seepage, stray currents and other potentially deleterious environmental factors on each of the material components comprising the structure. For most applications, permanent retaining walls should be designed for a minimum service life of 75 years. Retaining wall applications defined as temporary shall be considered to have a service life of 36 months or less.

A greater level of safety and/or longer service life, i.e., 100 years, may be appropriate for walls which support bridge abutments, buildings, critical utilities, or other facilities for which the consequences of poor performance or failure would be severe.

Permanent structures shall be designed to retain an aesthetically pleasing appearance, and be essentially maintenance free throughout their design service life.

11.5.2—Service Limit States

Abutments, piers, and walls shall be investigated for excessive vertical and lateral displacement, and overall stability, at the service limit state. Tolerable vertical and lateral deformation criteria for retaining walls shall be developed based on the function and type of wall, anticipated service life, and consequences of unacceptable movements to the wall and any potentially affected nearby structures, i.e., both structural and aesthetic. Overall stability shall be evaluated using limit equilibrium methods of analysis.

The provisions of Articles 10.6.2.2, 10.7.2.2, and 10.8.2.1 shall apply to the investigation of vertical wall movements. For anchored walls, deflections shall be estimated in accordance with the provisions of Article 11.9.3.1. For MSE walls, deflections shall be estimated in accordance with the provisions of Article 11.10.4.

C11.5.1

Design of walls to be essentially maintenance free does not preclude the need for periodic inspection of the wall to assess its condition throughout its design life.

C11.5.2

Vertical wall movements are primarily the result of soil settlement beneath the wall. For gravity and semigravity walls, lateral movement results from a combination of differential vertical settlement between the heel and the toe of the wall and the rotation necessary to develop active earth pressure conditions (see Article C3.11.1).

Tolerable total and differential vertical deformations for a particular retaining wall are dependent on the ability of the wall to deflect without causing damage to the wall elements or adjacent structures, or without exhibiting unsightly deformations.

Surveys of the performance of bridges indicate that horizontal abutment movements less than 1.5 in. can usually be tolerated by bridge superstructures without significant damage, as reported in Bozozuk (1978); Walkinshaw (1978); Moulton et al. (1985); and Wahls (1990). Earth pressures used in design of abutments should be selected consistent with the requirement that the abutment should not move more than 1.5 in. laterally.

Regarding impact to the wall itself, differential settlement along the length of the wall and to some extent from front to back of wall is the best indicator of the potential for retaining wall structural damage or overstress. Wall facing stiffness and ability to adjust incrementally to movement affect the ability of a given wall system to tolerate differential movements. The total and differential vertical deformation of a retaining wall should be small for rigid gravity and semigravity retaining walls, and for soldier pile walls with a cast-in-place facing. For walls with anchors, any downward movement can cause significant stress relaxation of the anchors.

MSE walls can tolerate larger total and differential vertical deflections than rigid walls. The amount of total and differential vertical deflection that can be tolerated depends on the wall facing material, configuration and timing of facing construction. A cast-in-place facing has the same vertical deformation limitations as the more rigid retaining wall systems. However, an MSE wall with a cast-in-place facing can be specified with a waiting period before the cast-in-place facing is constructed so that vertical (as well as horizontal) deformations have time to occur. An MSE wall with welded wire or geosynthetic facing can tolerate the most deformation. An MSE wall with multiple precast concrete panels cannot tolerate as much vertical deformation as flexible welded wire or geosynthetic facings because of potential damage to the precast panels and unsightly panel separation.

11.5.3—Strength Limit State

Abutments, walls, and piers shall be investigated at the strength limit states using Eq. 1.3.2.1-1 for:

- Bearing resistance failure,
- Lateral sliding,
- Loss of base contact due to eccentric loading,
- Pullout failure of anchors or soil reinforcements, and
- Structural failure.

11.5.4—Extreme Event Limit State

11.5.4.1—General Requirements

Abutments, walls, and piers shall be investigated at the extreme event limit state for:

- Overall stability failure,
- Bearing resistance failure,
- Lateral sliding,
- Loss of base contact due to eccentric loading,

- Pullout failure of anchors or soil reinforcements, and
- Structural failure.

The site-adjusted peak ground acceleration, A_s (i.e., $F_{pga} \times PGA$, as specified in Article 3.10.3.2), used for seismic design of retaining walls shall be determined in accordance with Article 3.10.

11.5.4.2—Extreme Event I, No Analysis

A seismic design shall not be considered mandatory for walls located in Seismic Zones 1 through 3, or for walls at sites where the site adjusted peak ground acceleration, A_s , is less than or equal to 0.4g, unless one or more of the following is true:

- Liquefaction induced lateral spreading or slope failure, or seismically induced slope failure, due to the presence of sensitive clays that lose strength during the seismic shaking, may impact the stability of the wall for the design earthquake.
- The wall supports another structure that is required, based on the applicable design code or specification for the supported structure, to be designed for seismic loading and poor seismic performance of the wall could impact the seismic performance of that structure.

The no-seismic-analysis option should be limited to internal and external seismic stability design of the wall. If the wall is part of a bigger slope, overall seismic stability of the wall and slope combination should still be evaluated.

These no-seismic-analysis provisions shall not be considered applicable to walls functioning as support piers for bridges.

The levels of peak ground acceleration at the ground surface in some areas will be low enough that a check on seismic loading is not required as other limit states will control the design.

C11.5.4.2

Article 11.5.4.2, related to specific seismic zones, may also be considered applicable to the corresponding Seismic design categories (SDC) A, B, and C, if using AASHTO's *Guide Specifications for LRFD Seismic Bridge Design*.

A summary of previous performance of walls in earthquakes, as well as key research findings that provide support to the provisions in Article 11.5.4.2, are provided in Appendix A11. In general, wall performance in past earthquakes has been very good, even in the largest, most damaging earthquakes, and cases where either wall collapse or severe wall displacements have occurred are rare. For those cases where collapse or severe displacement of walls did occur, those cases were mostly limited to situations where significant liquefaction occurred, where soil conditions behind or below the wall were very poor (e.g., soft silts and clays, marginally stable soils, water build up behind the wall) and ground accelerations were high, or where the wall was subjected to direct shear displacement of the fault. Furthermore, most of those failures were limited to walls that were very old. These wall failure situations are all well outside the limits specified in Article 11.5.4.2 where these specifications allow the designer to not conduct a detailed wall seismic design. However, walls meeting the requirements in Article 11.5.4.2 that allow a seismic analysis to not be conducted have demonstrated consistently good performance in past earthquakes.

Based on previous experience, walls that form tunnel portals have tended to exhibit more damage due to earthquakes than free standing walls. It is likely that the presence of the tunnel restricts the ability of the portal wall to move, increasing the seismic forces to which the wall is subjected. Therefore, a more detailed seismic analysis of tunnel portal walls should be considered even if the walls meet all the other no seismic analysis conditions specified in Article 11.5.4.2.

For walls that cross an active fault which could result in significant differential movement within the wall, a detailed seismic analysis should be considered even if the wall is located in Seismic Zones 1, 2, or 3.

Examples of other structures include bridges (e.g., the abutment foundation), buildings, pipelines or major utilities, pipe arches, or dams. If the wall supports another wall, a seismic design is not required for the lower wall, provided that the upper and lower wall can be designed as a single tiered structure and the limitations on the tiered structure for these provisions in Article 11.5.4.2, if in Seismic Zone 3 or lower, are met.

If the wall has abrupt changes in its alignment geometry (e.g., corners and short radius turns at an enclosed angle of 120 degrees or less), a seismic analysis of the wall should be considered for Seismic Zone 2 or higher. Based on past experience in earthquakes, wall corners tend to attract greater loads than free standing walls with generally straight alignments and have therefore suffered greater damage. The seismic details discussed in Articles 11.6.5.6 and 11.10.7.4 and their commentary will help to reduce the potential problems at corners that have occurred in past earthquakes. Note that the corner or abrupt alignment change enclosed angle as defined in Article 11.5.4.2 can either be internal or external to the wall.

A seismic analysis should be considered for Seismic Zone 2 or higher if either of the following is greater than 30 ft:

- The exposed wall height plus the average depth over the width of the wall of any soil surcharge present, or
- For tiered walls the sum of the exposed height of all the tiers plus the average soil surcharge depth, is greater than 30 ft.

A seismic analysis should be considered if in Seismic Zone 2 or higher, and if, for gravity and semigravity walls, the wall backfill does not meet the requirements of Article 7.3.6.3 of the *AASHTO LRFD Bridge Construction Specifications*, due to the possibility that the backfill will not be adequately drained to prevent water build-up in the backfill.

For Seismic Zone 2 or higher, if a seismic design is not conducted, it is still important to use good seismic details as specified in Articles 11.6.5.6 and Article 11.10.7.4.

If the wall is part of a bigger slope that potentially could fail during seismic loading, the overall seismic stability of the wall and slope as defined in Article 11.6.2.3 should be evaluated, as specified in Articles 11.5.4.1 and 11.5.8. If the wall is determined to have only a minor destabilizing effect on the overall stability of the slope during seismic loading, for example, a wall placed within a large slope or existing landslide that is marginally stable during static loading, it may not be practical to design the wall to be stable for overall stability for the Extreme Event I limit state. Addressing the landslide overall stability during seismic loading should be considered a separate effort not specifically addressed by these Specifications.

11.5.5—Resistance Requirement

Abutments, piers and retaining structures and their foundations and other supporting elements shall be proportioned by the appropriate methods specified in Articles 11.6, 11.7, 11.8, 11.9, 11.10, or 11.11 so that their resistance satisfies Article 11.5.6.

The factored resistance, R_R , calculated for each applicable limit state shall be the nominal resistance, R_n , multiplied by an appropriate resistance factor, ϕ , specified in Table 11.5.7-1.

11.5.6—Load Combinations and Load Factors

Abutments, piers and retaining structures and their foundations and other supporting elements shall be proportioned for all applicable load combinations specified in Article 3.4.1.

C11.5.5

Procedures for calculating nominal resistance are provided in Articles 11.6, 11.7, 11.8, 11.9, 11.10, and 11.11 for abutments and retaining walls, piers, nongravity cantilevered walls, anchored walls, mechanically stabilized earth walls, and prefabricated modular walls, respectively.

C11.5.6

Figures C11.5.6-1 and C11.5.6-2 show the typical application of load factors to produce the total extreme factored force effect for external stability of retaining walls for the strength limit state. Where live load surcharge is applicable, the factored surcharge force is generally included over the backfill immediately above the wall only for evaluation of foundation bearing resistance and structure design, as shown in Figure C11.5.6-3. The live load surcharge is not included over the backfill for evaluation of eccentricity, sliding or other failure mechanisms for which such surcharge would represent added resistance to failure. Likewise, the live load on a bridge abutment is included only for evaluation of foundation bearing resistance and structure design. The load factor for live load surcharge is the same for both vertical and horizontal load effects. Figure C11.5.6-3 is also applicable to seismic loading (i.e., Extreme Event I), except that the load factor for live load surcharge is γ_{EQ} instead of LL .

Figure C11.5.6-4 shows the typical application of load factors to produce the total extreme factored force effect for external stability of retaining walls for the Extreme Event I limit state.

The permanent and transient loads and forces shown in the figures include, but are not limited to:

- Permanent Loads

- DC = dead load of structural components and nonstructural attachments
- DW = dead load of wearing surfaces and utilities
- EH = horizontal earth pressure load
- ES = earth surcharge load
- EV = vertical pressure from dead load of earth fill

- Transient Loads

- LS = live load surcharge
- WA = water load and stream pressure

The subscripts V and H in Figure C11.5.6-4 denote vertical and horizontal components, respectively, of each force.

For the Extreme Event I limit state, the peak seismic lateral pressures acting on the wall should not be based on the maximum ground water elevation due to the low probability that the design peak seismic acceleration would be combined with the maximum ground water level. Instead, it is more appropriate to use the time-averaged mean groundwater elevation or a reasonable engineering estimate of this elevation.

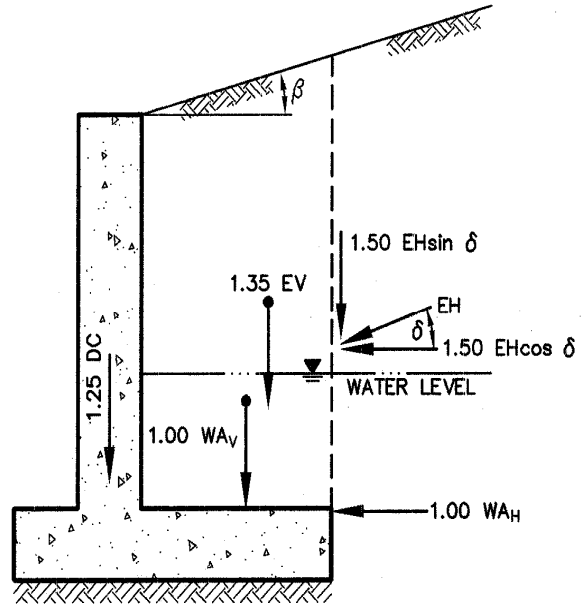

Figure C11.5.6-1—Typical Application of Load Factors for Bearing Resistance

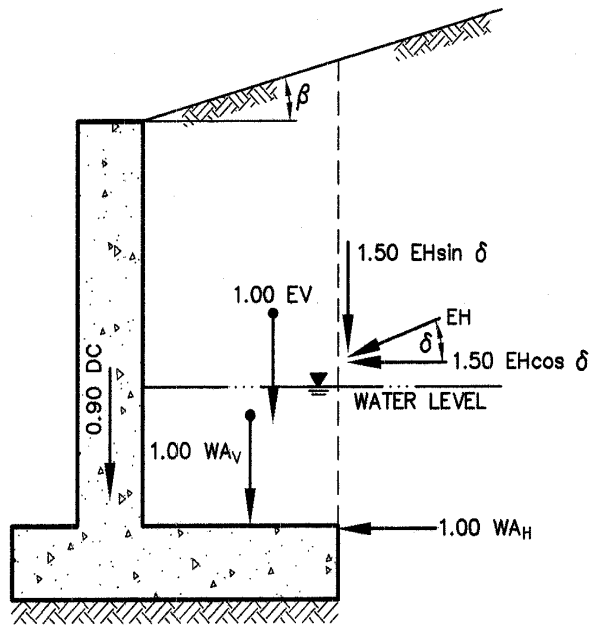
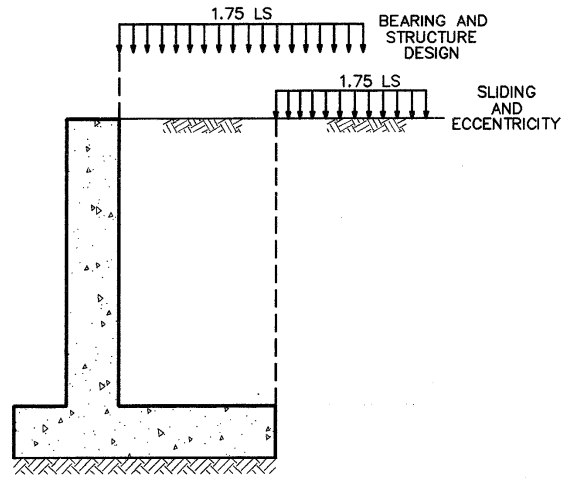
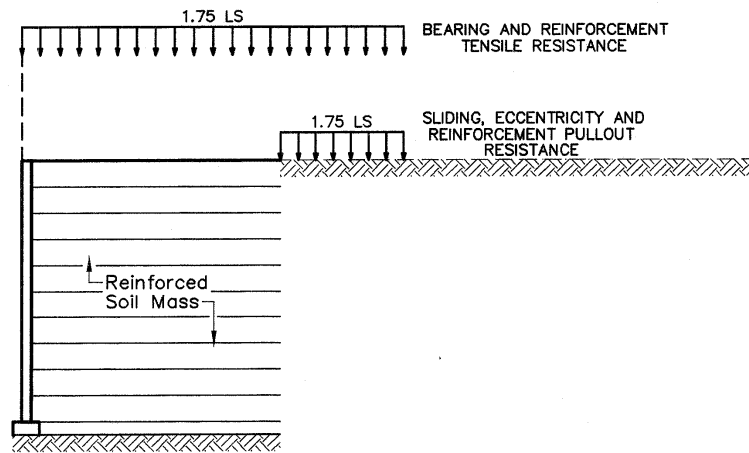

Figure C11.5.6-2—Typical Application of Load Factors for Sliding and Eccentricity



(a) CONVENTIONAL STRUCTURE



(b) MECHANICALLY STABILIZED EARTH STRUCTURE

Figure C11.5.6-3—Typical Application of Live Load Surcharge

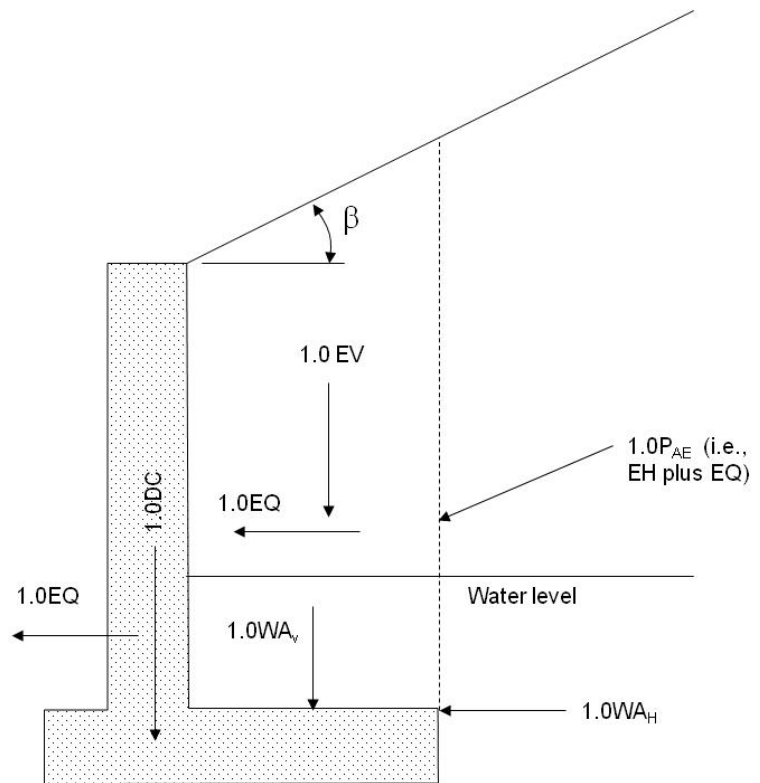

Figure C11.5.6-4—Typical Application of Load Factors for Bearing and Sliding Resistance and for Eccentricity in the Extreme Event I Limit State

For seismic loading effects on lateral earth pressure, the seismic load factor shall be applied to the entire lateral earth pressure load created by the earth mass retained by the wall or abutment. For any surcharge loads acting on the wall (e.g., *ES*) in combination with seismic load, *EQ*, the load factor for seismic loads, shall be applied.

Seismic loading of an earth mass retained by a wall is calculated using an extension of Coulomb theory or by limit equilibrium slope stability methods. The seismic loading causes the active soil wedge to increase, resulting in increased total load. The static loading cannot be separated from the seismic loading in this analysis, other than by artificial means through subtracting the static earth pressure from the total earth pressure calculated for seismic loading. Past allowable stress design practice has been to apply a single reduced safety factor to the entire lateral earth load combination. Therefore, one seismic load factor (typically a load factor of 1.0) is applied to the total earth pressure that occurs during seismic loading.

Regarding other loads acting in combination with the seismic loading and earth pressure, the load combination philosophy described for earth pressure also applies to be consistent with past allowable stress design practice for a no collapse design objective.

11.5.7—Resistance Factors—Service and Strength

Resistance factors for the service limit states shall be taken as 1.0, except as provided for overall stability in Article 11.6.2.3.

For the strength limit state, the resistance factors provided in Table 11.5.7-1 shall be used for wall design, unless region specific values or substantial successful experience is available to justify higher values.

C11.5.7

The resistance factors given in Table 11.5.7-1, other than those referenced back to Section 10, were calculated by direct correlation to allowable stress design rather than reliability theory.

Since the resistance factors in Table 11.5.7-1 were based on direct correlation to allowable stress design, the differences between the resistance factors for tensile

Resistance factors for geotechnical design of foundations that may be needed for wall support, unless specifically identified in Table 11.5.7-1, are as specified in Tables 10.5.5.2.2-1, 10.5.5.2.3-1, and 10.5.5.2.4-1.

If methods other than those prescribed in these Specifications are used to estimate resistance, the resistance factors chosen shall provide the same reliability as those given in Tables 10.5.5.2.2-1, 10.5.5.2.3-1, 10.5.5.2.4-1, and Table 11.5.7-1.

Vertical elements, such as soldier piles, tangent-piles and slurry trench concrete walls shall be treated as either shallow or deep foundations, as appropriate, for purposes of estimating bearing resistance, using procedures described in Articles 10.6, 10.7, and 10.8.

Some increase in the prescribed resistance factors may be appropriate for design of temporary walls consistent with increased allowable stresses for temporary structures in allowable stress design.

resistance of metallic versus geosynthetic reinforcement are based on historical differences in the level of safety applied to reinforcement designs for these two types of reinforcements. See Article C11.10.6.2.1 for additional comments regarding the differences between the resistance factors for metallic versus geosynthetic reinforcement.

Region-specific resistance factor values should be determined based on substantial statistical data combined with calibration or substantial successful experience to justify higher values. Smaller resistance factors should be used if site or material variability is anticipated to be unusually high or if design assumptions are required that increase design uncertainty that has not been mitigated through conservative selection of design parameters. See Allen et al. (2005) for additional guidance on calibration of resistance factors.

The evaluation of overall stability of walls or earth slopes with or without a foundation unit should be investigated at the service limit state based on the Service I Load Combination and an appropriate resistance factor.

Table 11.5.7-1—Resistance Factors for Permanent Retaining Walls

Wall-Type and Condition		Resistance Factor
Nongravity Cantilevered and Anchored Walls		
Axial compressive resistance of vertical elements		Article 10.5 applies
Passive resistance of vertical elements		0.75
Pullout resistance of anchors ⁽¹⁾	<ul style="list-style-type: none"> • Cohesionless (granular) soils • Cohesive soils • Rock 	0.65 ⁽¹⁾ 0.70 ⁽¹⁾ 0.50 ⁽¹⁾
Pullout resistance of anchors ⁽²⁾	<ul style="list-style-type: none"> • Where proof tests are conducted 	1.0 ⁽²⁾
Tensile resistance of anchor tendon	<ul style="list-style-type: none"> • Mild steel (e.g., ASTM A615 bars) • High strength steel (e.g., ASTM A722 bars) 	0.90 ⁽³⁾ 0.80 ⁽³⁾
Flexural capacity of vertical elements		0.90
Mechanically Stabilized Earth Walls, Gravity Walls, and Semigravity Walls		
Bearing resistance	<ul style="list-style-type: none"> • Gravity and semigravity walls • MSE walls 	0.55 0.65
Sliding		1.0
Tensile resistance of metallic reinforcement and connectors	Strip reinforcements ⁽⁴⁾ <ul style="list-style-type: none"> • Static loading Grid reinforcements ⁽⁴⁾⁽⁵⁾ <ul style="list-style-type: none"> • Static loading 	0.75 0.65
Tensile resistance of geosynthetic reinforcement and connectors	<ul style="list-style-type: none"> • Static loading 	0.90
Pullout resistance of tensile reinforcement	<ul style="list-style-type: none"> • Static loading 	0.90
Prefabricated Modular Walls		
Bearing		Article 10.5 applies
Sliding		Article 10.5 applies
Passive resistance		Article 10.5 applies

⁽¹⁾ Apply to presumptive ultimate unit bond stresses for preliminary design only in Article C11.9.4.2.

⁽²⁾ Apply where proof test(s) are conducted on every production anchor to a load of 1.0 or greater times the factored load on the anchor.

⁽³⁾ Apply to maximum proof test load for the anchor. For mild steel apply resistance factor to F_y . For high-strength steel apply the resistance factor to guaranteed ultimate tensile strength.

⁽⁴⁾ Apply to gross cross-section less sacrificial area. For sections with holes, reduce gross area in accordance with Article 6.8.3 and apply to net section less sacrificial area.

⁽⁵⁾ Applies to grid reinforcements connected to a rigid facing element, e.g., a concrete panel or block. For grid reinforcements connected to a flexible facing mat or which are continuous with the facing mat, use the resistance factor for strip reinforcements.

11.5.8—Resistance Factors—Extreme Event Limit State

Unless otherwise specified, all resistance factors shall be taken as 1.0 when investigating the extreme event limit state.

For overall stability of the retaining wall when earthquake loading is included, a resistance factor, ϕ , of 0.9 shall be used. For bearing resistance, a resistance factor of 0.8 shall be used for gravity and semigravity walls and 0.9 for MSE walls.

For tensile resistance of metallic reinforcement and connectors, when earthquake loading is included, the following resistance factors shall be used:

- Strip reinforcements, $\phi = 1.0$
- Grid reinforcement, $\phi = 0.85$

Table 11.5.7-1 Notes 4 and 5 also apply to these resistance factors for metallic reinforcements.

For tensile resistance of geosynthetic reinforcement and connectors, a resistance factor, ϕ , of 1.20 shall be used.

For pullout resistance of metallic and geosynthetic reinforcement, a resistance factor, ϕ , of 1.20 shall be used.

11.6—ABUTMENTS AND CONVENTIONAL RETAINING WALLS

11.6.1—General Considerations

11.6.1.1—General

Rigid gravity and semigravity retaining walls may be used for bridge substructures or grade separation and are generally for permanent applications.

Rigid gravity and semigravity walls shall not be used without deep foundation support where the bearing soil/rock is prone to excessive total or differential settlement.

C11.5.8

A resistance factor of 1.0 is recommended for the extreme event limit state in view of the unlikely occurrence of the loading associated with the design earthquake. The choice of 1.0 is influenced by the following factors:

- For competent soils that are not expected to lose strength during seismic loading (e.g., due to liquefaction of saturated cohesionless soils or strength reduction of sensitive clays), the use of static strengths for seismic loading is usually conservative, as rate-of-loading effects tend to increase soil strength for transient loading.
- Earthquake loads are transient in nature and hence, if soil yield occurs, the net effect is an accumulated small deformation as opposed to foundation failure. This assumes that global stability is adequate.

Using a resistance factor of 1.0 for soil assumes ductile behavior. While this is a correct assumption for many soils, it is inappropriate for brittle soils where there is a significant post-peak strength loss (e.g., stiff over-consolidated clays, sensitive soils). For such conditions, special studies will be required to determine the appropriate combination of resistance factor and soil strength.

For bearing resistance, a slightly lower resistance factor of 0.8 is recommended for gravity and semigravity walls and 0.9 for MSE walls to reduce the possibility that a bearing resistance failure could occur before the wall moves laterally in sliding, reducing the likelihood of excessive wall tilting or collapse, consistent with the design objective of no collapse.

C11.6.1.1

Conventional retaining walls are generally classified as rigid gravity or semigravity walls, examples of which are shown in Figure C11.6.1.1-1. These types of walls can be effective for both cut and fill wall applications.

Excessive differential settlement, as defined in Article C11.6.2.2 can cause cracking, excessive bending or shear stresses in the wall, or rotation of the wall structure.

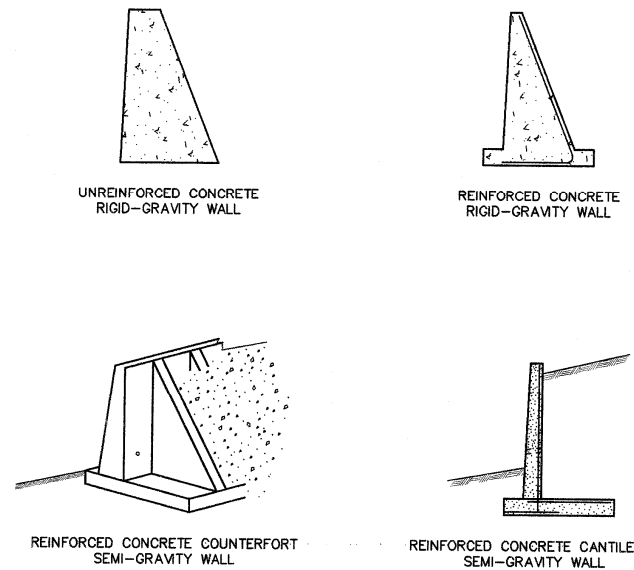

Figure C11.6.1.1-1—Typical Rigid Gravity and Semigravity Walls

11.6.1.2—Loading

Abutments and retaining walls shall be investigated for:

- Lateral earth and water pressures, including any live and dead load surcharge;
- The self weight of the abutment/wall;
- Loads applied from the bridge superstructure;
- Temperature and shrinkage deformation effects; and
- Earthquake loads, as specified herein, in Section 3 and elsewhere in these Specifications.

The provisions of Articles 3.11.5 and 11.5.5 shall apply. For stability computations, the earth loads shall be multiplied by the maximum and/or minimum load factors given in Table 3.4.1-2, as appropriate.

The design shall be investigated for any combination of forces which may produce the most severe condition of loading. The design of abutments on mechanically stabilized earth and prefabricated modular walls shall be in accordance with Articles 11.10.11 and 11.11.6.

For computing load effects in abutments, the weight of filling material directly over an inclined or stepped rear face, or over the base of a reinforced concrete spread footing may be considered as part of the effective weight of the abutment.

Where spread footings are used, the rear projection shall be designed as a cantilever supported at the abutment stem and loaded with the full weight of the superimposed material, unless a more exact method is used.

C11.6.1.2

Cohesive backfills are difficult to compact. Because of the creep of cohesive soils, walls with cohesive backfills designed for active earth pressures will continue to move gradually throughout their lives, especially when the backfill is soaked by rain or rising groundwater levels. Therefore, even if wall movements are tolerable, walls backfilled with cohesive soils should be designed with extreme caution for pressures between the active and at-rest cases assuming the most unfavorable conditions. Consideration must be given for the development of pore water pressure within the soil mass in accordance with Article 3.11.3. Appropriate drainage provisions should be provided to prevent hydrostatic and seepage forces from developing behind the wall. In no case shall highly plastic clay be used for backfill.

11.6.1.3—Integral Abutments

Integral abutments shall be designed to resist and/or absorb creep, shrinkage and thermal deformations of the superstructure.

Movement calculations shall consider temperature, creep, and long-term prestress shortening in determining potential movements of abutments.

Maximum span lengths, design considerations, details should comply with recommendations outlined in FHWA Technical Advisory T 5140.13 (1980), except where substantial local experience indicates otherwise.

To avoid water intrusion behind the abutment, the approach slab should be connected directly to the abutment (not to wingwalls), and appropriate provisions should be made to provide for drainage of any entrapped water.

11.6.1.4—Wingwalls

Wingwalls may either be designed as monolithic with the abutments, or be separated from the abutment wall with an expansion joint and designed to be free standing.

The wingwall lengths shall be computed using the required roadway slopes. Wingwalls shall be of sufficient length to retain the roadway embankment and to furnish protection against erosion.

11.6.1.5—Reinforcement

11.6.1.5.1—Conventional Walls and Abutments

Reinforcement to resist the formation of temperature and shrinkage cracks shall be designed as specified in Article 5.10.8.

11.6.1.5.2—Wingwalls

Reinforcing bars or suitable rolled sections shall be spaced across the junction between wingwalls and abutments to tie them together. Such bars shall extend into the masonry on each side of the joint far enough to develop the strength of the bar as specified for bar reinforcement, and shall vary in length so as to avoid planes of weakness in the concrete at their ends. If bars are not used, an expansion joint shall be provided and the wingwall shall be keyed into the body of the abutment.

11.6.1.6—Expansion and Contraction Joints

Contraction joints shall be provided at intervals not exceeding 30.0 ft and expansion joints at intervals not exceeding 90.0 ft for conventional retaining walls and abutments. All joints shall be filled with approved filling material to ensure the function of the joint. Joints in abutments shall be located approximately midway between the longitudinal members bearing on the abutments.

C11.6.1.3

Deformations are discussed in Article 3.12.

Integral abutments should not be constructed on spread footings founded or keyed into rock unless one end of the span is free to displace longitudinally.

11.6.2—Movement and Stability at the Service Limit State

11.6.2.1—Abutments

The provisions of Articles 10.6.2.4, 10.6.2.5, 10.7.2.3 through 10.7.2.5, 10.8.2.2 through 10.8.2.4, and 11.5.2 shall apply as applicable.

11.6.2.2—Conventional Retaining Walls

The provisions of Articles 10.6.2.4, 10.6.2.5, 10.7.2.3 through 10.7.2.5, 10.8.2.2 through 10.8.2.4, and 11.5.2 apply as applicable.

11.6.2.3—Overall Stability

The overall stability of the retaining wall, retained slope and foundation soil or rock shall be evaluated for all walls using limiting equilibrium methods of analysis. The overall stability of temporary cut slopes to facilitate construction shall also be evaluated. Special exploration, testing and analyses may be required for bridge abutments or retaining walls constructed over soft deposits.

The evaluation of overall stability of earth slopes with or without a foundation unit should be investigated at the Service I Load Combination and an appropriate resistance factor. In lieu of better information, the resistance factor, ϕ , may be taken as:

- Where the geotechnical parameters are well defined, and the slope does not support or contain a structural element..... 0.75
- Where the geotechnical parameters are based on limited information, or the slope contains or supports a structural element 0.65

C11.6.2.2

For a conventional reinforced concrete retaining wall, experience suggests that differential wall settlements on the order of 1 in 500 to 1 in 1,000 may overstress the wall.

C11.6.2.3

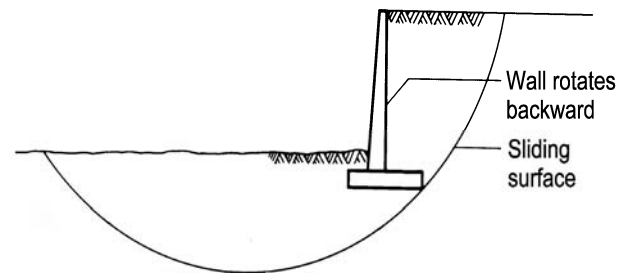

Figure C11.6.2.3-1—Retaining Wall Overall Stability Failure

Figure C11.6.2.3-1 shows a retaining wall overall stability failure. Overall stability is a slope stability issue, and, therefore, is considered a service limit state check.

The Modified Bishop, simplified Janbu or Spencer methods of analysis may be used.

Soft soil deposits may be subject to consolidation and/or lateral flow which could result in unacceptable long-term settlements or horizontal movements.

With regard to selection of a resistance factor for evaluation of overall stability of walls, examples of structural elements supported by a wall that may justify the use of the 0.65 resistance factor include a bridge or pipe arch foundation, a building foundation, a pipeline, a critical utility, or another retaining wall. If the structural element is located beyond the failure surface for external stability behind the wall illustrated conceptually in Figure 11.10.2-1, a resistance factor of 0.75 may be used.

Available slope stability programs produce a single factor of safety, FS . The specified resistance factors are essentially the inverse of the FS that should be targeted in the slope stability program.

11.6.3—Bearing Resistance and Stability at the Strength Limit State

11.6.3.1—General

Abutments and retaining walls shall be proportioned to ensure stability against bearing capacity failure, overturning, and sliding. Safety against deep-seated foundation failure shall also be investigated, in accordance with the provisions of Article 10.6.2.5.

11.6.3.2—Bearing Resistance

Bearing resistance shall be investigated at the strength limit state using factored loads and resistances, assuming the following soil pressure distributions:

- Where the wall is supported by a soil foundation:

the vertical stress shall be calculated assuming a uniformly distributed pressure over an effective base area as shown in Figure 11.6.3.2-1.

The vertical stress shall be calculated as follows:

$$\sigma_v = \frac{\sum V}{B - 2e} \quad (11.6.3.2-1)$$

where:

$\sum V$ = the summation of vertical forces, and the other variables are as defined in Figure 11.6.3.2-1

- Where the wall is supported by a rock foundation:

the vertical stress shall be calculated assuming a linearly distributed pressure over an effective base area as shown in Figure 11.6.3.2-2. If the resultant is within the middle one-third of the base:

$$\sigma_{vmax} = \frac{\sum V}{B} \left(1 + 6 \frac{e}{B} \right) \quad (11.6.3.2-2)$$

$$\sigma_{vmin} = \frac{\sum V}{B} \left(1 - 6 \frac{e}{B} \right) \quad (11.6.3.2-3)$$

where the variables are as defined in Figure 11.6.3.2-2. If the resultant is outside the middle one-third of the base:

$$\sigma_{vmax} = \frac{2 \sum V}{3[(B/2) - e]} \quad (11.6.3.2-4)$$

$$\sigma_{vmin} = 0 \quad (11.6.3.2-5)$$

where the variables are as defined in Figure 11.6.3.2-2.

C11.6.3.2

See Figure 11.10.10.1-1 for an example of how to calculate the vertical bearing stress where the loading is more complex. Though this figure shows the application of superposition principles to mechanically stabilized earth walls, these principles can also be directly applied to conventional walls.

See Article C11.5.5 for application of load factors for bearing resistance and eccentricity.

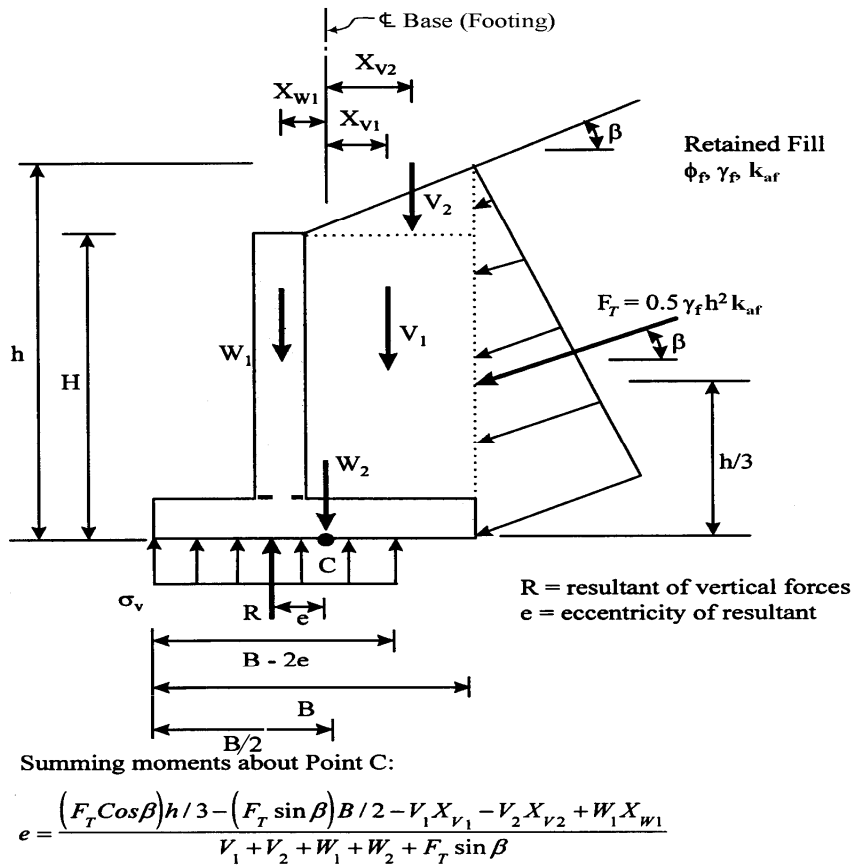
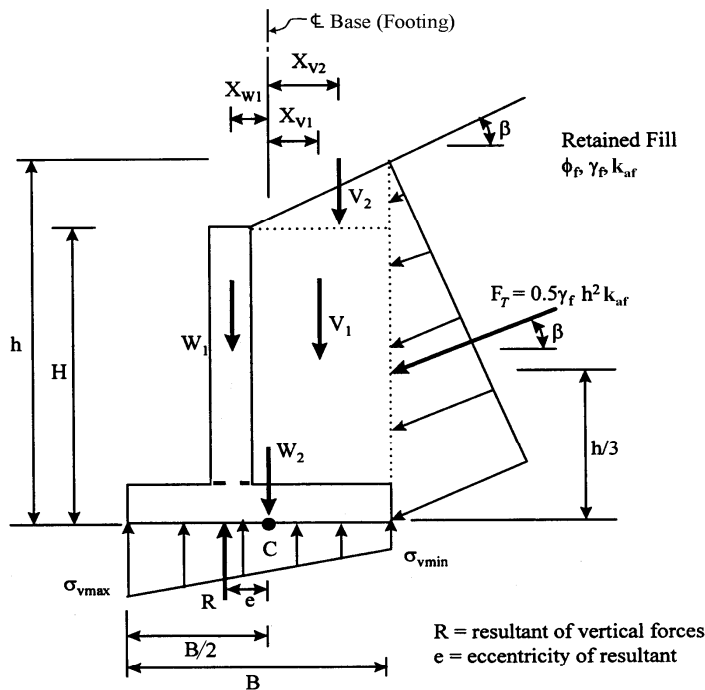

Figure 11.6.3.2-1—Bearing Stress Criteria for Conventional Wall Foundations on Soil



If $e > B/6$, σ_{vmin} will drop to zero, and as “e” increases, the portion of the heel of the footing which has zero vertical stress increases.

Summing moments about Point C:

$$e = \frac{(F_T \cos \beta)h/3 - (F_T \sin \beta)B/2 - V_1 X_{v1} - V_2 X_{v2} + W_1 X_{w1}}{V_1 + V_2 + W_1 + W_2 + F_T \sin \beta}$$

Figure 11.6.3.2—Bearing Stress Criteria for Conventional Wall Foundations on Rock

11.6.3.3—Eccentricity Limits

For foundations on soil, the location of the resultant of the reaction forces shall be within the middle two-thirds of the base width.

For foundations on rock, the location of the resultant of the reaction forces shall be within the middle nine-tenths of the base width.

11.6.3.4—Subsurface Erosion

For walls constructed along rivers and streams, scour of foundation materials shall be evaluated during design, as specified in Article 2.6.4.4.2. Where potential problem conditions are anticipated, adequate protective measures shall be incorporated in the design.

The provisions of Article 10.6.1.2 shall apply.
The hydraulic gradient shall not exceed:

- For silts and cohesive soils: 0.20
- For other cohesionless soils: 0.30

Where water seeps beneath a wall, the effects of uplift and seepage forces shall be considered.

C11.6.3.3

The specified criteria for the location of the resultant, coupled with investigation of the bearing pressure, replace the investigation of the ratio of stabilizing moment to overturning moment. Location of the resultant within the middle two-thirds of the base width for foundations on soil is based on the use of plastic bearing pressure distribution for the limit state.

C11.6.3.4

The measures most commonly used to ensure that piping does not occur are:

- Seepage control,
- Reduction of hydraulic gradient, and
- Protective filters.

Seepage effects may be investigated by constructing a flow net, or in certain circumstances, by using generally accepted simplified methods.

11.6.3.5—Passive Resistance

Passive resistance shall be neglected in stability computations, unless the base of the wall extends below the depth of maximum scour, freeze-thaw or other disturbances. In the latter case, only the embedment below the greater of these depths shall be considered effective.

Where passive resistance is utilized to ensure adequate wall stability, the calculated passive resistance of soil in front of abutments and conventional walls shall be sufficient to prevent unacceptable forward movement of the wall.

The passive resistance shall be neglected if the soil providing passive resistance is, or is likely to become soft, loose, or disturbed, or if the contact between the soil and wall is not tight.

11.6.3.6—Sliding

The provisions of Article 10.6.3.4 shall apply.

11.6.4—Safety against Structural Failure

The structural design of individual wall elements and wall foundations shall comply with the provisions of Sections 5, 6, 7, and 8.

The provisions of Article 10.6.1.3 shall be used to determine the distribution of contact pressure for structural design of footings.

11.6.5—Seismic Design for Abutments and Conventional Retaining Walls**11.6.5.1—General**

Rigid gravity and semigravity retaining walls and abutments shall be designed to meet overall stability, external stability, and internal stability requirements during seismic loading. The procedures specified in Article 11.6.2.3 for overall stability, Article 11.6.3 for bearing stability, and Article 10.6.3.4 for sliding stability shall be used but including seismically induced earth pressure and inertial forces and using Extreme Event I limit state load and resistance factors as specified in Article 11.5.8.

For seismic eccentricity evaluation of walls with foundations on soil and rock, the location of the resultant of the reaction forces shall be within the middle two-thirds of the base for $\gamma_{EQ} = 0.0$ and within the middle eight-tenths of the base for $\gamma_{EQ} = 1.0$. For values of γ_{EQ} between 0.0 and 1.0, the resultant location restriction shall be obtained by linear interpolation of the values given in this Article.

C11.6.3.5

Unacceptable deformations may occur before passive resistance is mobilized. Approximate deformations required to mobilize passive resistance are discussed in Article C3.11.1, where H in Table C3.11.1-1 is the effective depth of passive restraint.

C11.6.5.1

The estimation of seismic design forces should account for wall inertia forces in addition to the equivalent static-forces. For semigravity walls in which the footing protrudes behind the back of the wall face (i.e., the heel), the weight of the soil located directly above the heel of the footing should be included in the calculated wall inertial force.

Where a wall supports a bridge structure, the seismic design forces should also include seismic forces transferred from the bridge through bearing supports which do not freely slide, e.g., elastomeric bearings in accordance with Article 14.6.3.

For bridge abutments, the abutment seismic design should be conducted in accordance with Articles 5.2 and 6.7 of AASHTO's *Guide Specifications for LRFD Seismic Bridge Design* but with the following exceptions:

- k_h should be determined as specified in Article 11.6.5.2 and
- Lateral earth pressures should be estimated in accordance with Article 11.6.5.3.

To evaluate safety against structural failure (i.e., internal stability) for seismic design, the structural design of the wall elements shall comply with the provisions of Sections 5, 6, 7, and 8.

The total lateral force to be applied to the wall due to seismic and earth pressure loading, P_{seis} , should be determined considering the combined effect of P_{AE} and P_{IR} , in which:

$$P_{IR} = k_h(W_w + W_s) \quad (11.6.5.1-1)$$

and where:

- P_{AE} = dynamic lateral earth pressure force
- P_{IR} = horizontal inertial force due to seismic loading of the wall mass
- k_h = seismic horizontal acceleration coefficient
- W_w = the weight of the wall
- W_s = the weight of soil that is immediately above the wall, including the wall heel

To investigate the wall stability considering the combined effect of P_{AE} and P_{IR} and considering them not to be concurrent, the following two cases should be investigated:

- Combine 100 percent of the seismic earth pressure P_{AE} with 50 percent of the wall inertial force P_{IR} and
- Combine 50 percent of P_{AE} but no less than the static active earth pressure force (i.e., F_1 in Figure 11.10.5.2-1), with 100 percent of the wall inertial force P_{IR} .

The most conservative result from these two analyses should be used for design of the wall. Alternatively, if approved by the Owner, more sophisticated numerical methods may be used to investigate nonconcurrency. For competent soils that do not lose strength under seismic loading, static strength parameters should be used for seismic design.

- For cohesive soils, total stress strength parameters based on undrained tests should be used during the seismic analysis.
- For clean cohesionless soils, the effective stress friction angle should be used.

The static lateral earth pressure force acting behind the wall is already included in P_{AE} (i.e., P_{AE} is the combination of the static and seismic lateral earth pressure). See Articles 3.11.6.3 and 11.10.10.1 for definition of terms in Figure 11.6.5.1-1 not specifically defined in this Article.

Since P_{AE} is the combined lateral earth pressure force resulting from static earth pressure plus dynamic effects, the static earth pressure as calculated based on the lateral earth pressure coefficient K_a should not be added to the seismic earth pressure calculated in Article 11.6.5.3. The static lateral earth pressure coefficient, K_a , is, in effect, increased during seismic loading to K_{AE} (see Article 11.6.5.3) due to seismically induced inertial forces on the active wedge, and the potential increase in the volume of the active wedge itself due to flattening of the active failure surface. P_{AE} does not include any additional lateral forces caused by permanent surcharge loads located above the wall (e.g., the static force F_p , and the dynamic force $k_h W_{\text{surcharge}}$ in Figure 11.6.5.1-1, in which $W_{\text{surcharge}}$ is the weight of the surcharge). If the generalized limit equilibrium method (GLE) is used to calculate seismic lateral earth pressure on the wall, the effect of the surcharge on the total lateral force acting on the wall during seismic loading may, however, be taken directly into account when determining P_{AE} . Note that the inertial force due to the weight of the concentrated surcharge load, $k_h W_{\text{surcharge}}$, and the static force F_p are separate and both act during seismic loading. They must therefore both be included in the seismic wall stability analysis. F_p is calculated as specified in Article 3.11.6.

For evaluating external stability of the wall and for evaluating safety against structural failure of the wall (internal stability), the simplest design approach that will ensure a safe result is to combine the total seismic earth pressure force with the inertial response of the wall section, assuming both are in phase. This approach is conservative in that the peak inertial response of the wall mass is not likely to occur at the same time as the peak seismic active pressure. Previous design practice, at least for MSE walls, has been to combine the full wall inertial force with only 50 percent of the dynamic increment of the total earth pressure (i.e., $P_{AE} - P_A$) to account for this lack of concurrence in the design forces.

Research using centrifuge testing of reduced scale walls by Al Atik and Sitar (2010) indicated that these two seismic forces are out of phase, in that when dynamic earth pressure was at its maximum, the wall inertial force was at its minimum and was very close to zero. When the wall inertial force was at its maximum, the total seismic earth pressure (i.e., P_{AE}) was close to its static value. They also indicated, however, that more coincidence between these two forces may still be possible for some wall configurations and ground motions. Nakamura (2006) made similar observations regarding lack of concurrence of these forces based on dynamic centrifuge testing he conducted. This research indicates that treating the two forces as nonconcurrent is justified in most cases.

- For sensitive cohesive soils or saturated cohesionless soils, the potential for earthquake-induced strength loss shall be addressed in the analysis.

See Al Atik and Sitar (2010) and Nakamura (2006) for examples of the application of numerical methods to investigate this issue of nonconcurrent forces.

The inertial force associated with the soil mass on the wall heel behind the retaining wall is not added to the active seismic earth pressure when structurally designing the retaining wall. The basis for excluding this inertial force is that movement of this soil mass is assumed to be in phase with the structural wall system with the inertial load transferred through the heel of the wall. Based on typical wave lengths associated with seismic loading, this is considered a reasonable assumption. However, the inertial force for the soil mass over the wall heel is included when determining the external stability of the wall.

Additional discussion and guidance on the selection of soil parameters for seismic design of walls and the potential consideration of soil cohesion are provided by Anderson et al. (2008).

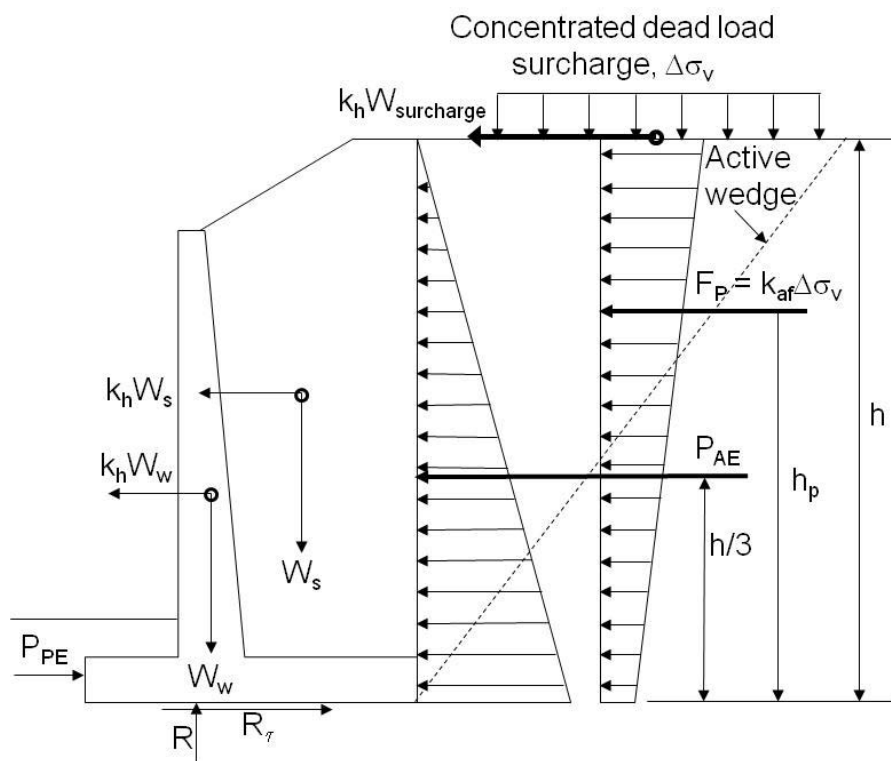

Figure 11.6.5.1-1—Seismic Force Diagram for Gravity Wall External Stability Evaluation

11.6.5.2—Calculation of Seismic Acceleration Coefficients for Wall Design

11.6.5.2.1—Characterization of Acceleration at Wall Base

The seismic horizontal acceleration coefficient (k_h) for computation of seismic lateral earth pressures and loads shall be determined on the basis of the *PGA* at the ground surface (i.e., $k_{h0} = F_{pga} PGA = A_s$, where k_{h0} is the seismic horizontal acceleration coefficient assuming zero wall displacement occurs). The acceleration coefficient determined at the original ground surface should be considered to be the acceleration coefficient acting at the wall base. For walls founded on Site Class A or B soil (hard or soft rock), k_{h0} shall be based on 1.2 times the site-adjusted peak ground acceleration coefficient (i.e., $k_{h0} = 1.2F_{pga}PGA$).

The seismic vertical acceleration coefficient, k_v , should be assumed to be zero for the purpose of calculating lateral earth pressures, unless the wall is significantly affected by near fault effects (see Article 3.10), or if relatively high vertical accelerations are likely to be acting concurrently with the horizontal acceleration.

11.6.5.2.2—Estimation of Acceleration Acting on Wall Mass

The seismic lateral wall acceleration coefficient, k_h , shall be determined considering the effects of wave scattering or ground motion amplification within the wall and the ability of the wall to displace laterally. For wall heights less than 60.0 ft, simplified pseudostatic analyses may be considered acceptable for use in determining the design wall mass acceleration. For wall heights greater than 60.0 ft, special dynamic soil structure interaction design analyses should be performed to assess the effect of spatially varying ground motions within and behind the wall and lateral deformations on the wall mass acceleration.

The height of wall, h , shall be taken as the distance from the bottom of the heel of the retaining structure to the ground surface directly above the heel.

If the wall is free to move laterally under the influence of seismic loading and if lateral wall movement during the design seismic event is acceptable to the Owner, k_{h0} should be reduced to account for the allowed lateral wall deformation. The selection of a maximum acceptable lateral deformation should take into consideration the effect that deformation will have on the stability of the wall under consideration, the desired seismic performance level, and the effect that deformation could have on any facilities or structures supported by the wall. Where the wall is capable of displacements of 1.0 to 2.0 in. or more during the design seismic event, k_h may be reduced to $0.5k_{h0}$ without conducting a deformation analysis using the Newmark

C11.6.5.2.1

A_s is determined as specified in Article 3.10.

In most situations, vertical and horizontal acceleration are at least partially out of phase. Therefore, k_v is usually rather small when k_h is near its maximum value. The typical assumption is to assume that k_v is zero for wall design.

C11.6.5.2.2

The designer may use k_h for wall design without accounting for wave scattering and lateral deformation effects; however, various studies have shown that the ground motions in the mass of soil behind the wall will often be lower than k_{h0} at the ground surface, particularly for taller walls. However, in some cases, it is possible to have amplification of the ground motion in the wall relative to the wall base ground motion.

The desired performance of walls during a design seismic event can range from allowing limited damage to the wall or displacement of the wall to requiring damage-free, post-earthquake conditions. In many cases, a well-designed gravity or semigravity wall could slide several inches and perhaps even a foot or more, as well as tilt several degrees, without affecting the function of the wall or causing collapse, based on past performance of walls in earthquakes. However, the effect of such deformation on the facilities or structures located above, behind, or in front of the wall must also be considered when establishing an allowable displacement.

Recent work completed as part of NCHRP Report 611 (Anderson et al., 2008) concluded that, when using the Newmark method, the amount of permanent ground displacement associated with $k_h = 0.5k_{h0}$ will in most cases be less than 1.0 to 2.0 in. (i.e., use of $k_h = 0.5k_{h0}$ provides conservative results).

Details of specific simplified procedures that may be used to estimate wave scattering effects and lateral wall deformations to determine k_h are provided in

method (Newmark, 1965) or a simplified version of it. This reduction in k_h shall also be considered applicable to the investigation of overall stability of the wall and slope.

A Newmark sliding block analysis or a simplified form of that type of analysis should be used to estimate lateral deformation effects, unless the Owner approves the use of more sophisticated numerical analysis methods to establish the relationship between k_h and the wall displacement. Simplified Newmark analyses should only be used if the assumptions used to develop them are valid for the wall under consideration.

11.6.5.3—Calculation of Seismic Active Earth Pressures

Seismic active and passive earth pressures for gravity and semigravity retaining walls shall be determined following the methods described in this Article. Site conditions, soil and retaining wall geometry, and the earthquake ground motion determined for the site shall be considered when selecting the most appropriate method to use.

The seismic coefficient (k_h) used to calculate seismic earth pressures shall be the site-adjusted peak ground surface acceleration identified in Article 11.6.5.2.1 (i.e., A_s) after adjustments for 1) spectral or wave scattering effects and 2) limited amounts of permanent deformation as determined appropriate for the wall and anything the wall movement could affect (Article 11.6.5.2.2). The vertical acceleration coefficient (k_v) should be assumed to be zero for design as specified in Article 11.6.5.2.1.

For seismic active earth pressures, either the Mononobe-Okabe (M-O) Method or the Generalized Limit Equilibrium (GLE) Method should be used. For wall geometry or site conditions for which the M-O Method is not suitable, the GLE Method should be used.

The M-O Method shall be considered acceptable for determination of seismic active earth pressures only where:

- The material behind the wall can be reasonably approximated as a uniform, cohesionless soil within a zone defined by a 3H:1V wedge from the heel of the wall,
- The backfill is not saturated and in a loose enough condition such that it can liquefy during shaking, and

Appendix A11. Those simplified procedures include Kavazanjian et al. (2003), Anderson et al. (2008), and Bray et al. (2009, 2010). Additional background needed to conduct a full Newmark sliding block analysis is also provided in Appendix A11.

Alternate Methods of Estimating Permanent Displacement

The simplified, Newmark Method-based equations given above present a relatively quick method of estimating the yield acceleration for a given maximum acceptable displacement or, alternatively, the displacements that will occur if the capacity to demand (C/D) ratio for a limiting equilibrium stability analysis is less than 1.0. Alternatively, two-dimensional numerical methods that allow seismic time history analyses may be used to estimate permanent displacements. Such models require considerable expertise in the set-up and interpretation of model results, particularly relative to the selection of strength parameters consistent with seismic loading. For this reason, use of this alternate approach should be adopted only with the Owner's concurrence.

C11.6.5.3

The suitability of the method used to determine active and passive earth seismic pressures should be determined after a review of features making up the static design, such as backfill soils and slope above the retaining wall. These conditions, along with the ground motion for a site, will affect the method selection.

The complete M-O equation is provided in Appendix A11. The M-O equation for seismic active earth pressure is based on the Coulomb earth pressure theory and is therefore limited to design of walls that have homogeneous, dry cohesionless backfill. The M-O equation has been shown to be most applicable when the backfill is homogenous and can be characterized as cohesionless.

Another important limitation of the M-O equation is that there are combinations of acceleration and slope angle in which real solutions to the equation are no longer possible or that result in values that rapidly approach infinity. The contents of the radical in this equation must be positive for a real solution to be possible. In past practice, when the combination of acceleration and slope angle results in a negative number within the radical in the equation, rather than allowing that quantity to become negative, it was artificially set at zero. While this practice made it possible to get a value of K_{AE} , it also tended to produce excessively conservative results. Therefore, in such cases it is better to use an alternative method.

- The combination of peak ground acceleration and backslope angle do not exceed the friction angle of the soil behind the wall, as specified in Eq. 11.6.5.3-1.

$$\phi \geq i + \theta_{MO} = i + \arctan\left(\frac{k_h}{1 - k_v}\right) \quad (11.6.5.3-1)$$

where:

- ϕ = the wall backfill friction angle
- i = backfill slope angle (degrees)
- k_h = the horizontal acceleration coefficient
- k_v = the vertical acceleration coefficient

Once K_{AE} is determined, the seismic active force, P_{AE} , shall be determined as:

$$P_{AE} = 0.5 \gamma h^2 K_{AE} \quad (11.6.5.3-2)$$

where:

- K_{AE} = seismic active earth pressure coefficient (dim)
- γ = the soil unit weight behind the wall (kips/ft³)
- h = the total wall height, including any soil surcharge present, at the back of the wall

The external active force computed from the generalized limit equilibrium method, distributed over the wall height h , shall be used as the seismic earth pressure.

The equivalent pressure representing the total static and seismic active force (P_{AE}) as calculated by either method should be distributed using the same distribution as the static earth pressure used to design the wall when used for external stability evaluations, as illustrated in Figure 11.6.5.1-1, but no less than $H/3$. For the case when a sloping soil surcharge is present behind the wall face (h in Figure 11.6.5.1-1), this force shall be distributed over the total height, h .

For complex wall systems or complex site conditions, with the owner's approval, dynamic numerical soil structure interaction (SSI) methods should also be considered.

For many situations, gravity and semigravity walls are constructed by cutting into an existing slope where the soil properties differ from the backfill that is used behind the retaining wall. In situations where soil conditions are not homogeneous and the failure surface is flatter than the native slope, seismic active earth pressures computed for the M-O equation using the backfill properties may no longer be valid, particularly if there is a significant difference in properties between the native and backfill soils.

However, the M-O Method has been used in past design practice for estimating seismic earth pressures for many of these situations due to lack of an available alternative. Various approaches to force the method to be usable for such situations have been used, such as estimating some type of average soil property for layered soil conditions or limiting the acceleration to prevent the radical in the equation from being negative, among others. With the exception of seismic passive pressure estimation, this practice has typically resulted in excessively conservative designs and it is not recommended to continue this practice.

The GLE Method consists of conducting a seismic slope stability analysis in which k_h is used as the acceleration coefficient, typically using a computer program in which the applied force necessary to maintain equilibrium (i.e., a capacity/demand ratio of 1.0) under seismic loading is determined. This force is P_{AE} . Specific procedures used to conduct this method are provided in Appendix A11. The GLE Method should be used when the M-O Method is not suitable due to the wall geometry, seismic acceleration level, or site conditions.

The Coulomb Wedge Equilibrium Method, also referred to as the trial wedge method, as described in Peck et al. (1974) and Caltrans (2010), may also be used for situations when the M-O method is not suitable but a hand calculation method is desired, provided that the soil conditions are not too complex (e.g., layered soil conditions behind the wall). Other than the potential ability to use the trial wedge method as a hand calculation method, it has no real advantages over the GLE method.

Recent studies have indicated that classic limit equilibrium based methods such as the M-O, GLE, and the Coulomb Wedge Equilibrium methods may be overly conservative even if the limitations listed above are considered. See Bray et al. (2010) and Lew et al. (2010a, 2010b) with regard to the generation of seismic earth pressures behind walls and the applicability of the Mononobe-Okabe or similar method.

For cases in which the wall seismic design result appears to be excessively conservative relative to past experience in earthquakes, other than taking advantage of the no seismic analysis provisions in Article 11.5.4.2, there are no simple solutions; numerical dynamic soil structure interaction (SSI) modeling may need to be considered. See Bray et al. (2010) for an example. Dynamic numerical SSI solutions may also be needed

for more complex wall systems and for walls in which the seismic loading is severe. Due to the complexities of such analyses, an independent peer review of the analysis and results is recommended.

Past practice for locating the resultant of the static and seismic earth pressure for external wall stability has been to either assume a uniform distribution of lateral earth pressure for the combined static plus seismic stress or, if the static and seismic components of earth pressure are treated separately, using an inverted trapezoid for the seismic component, with the seismic force located at $0.6h$ above the wall base, and combining that force with the normal static earth pressure distribution (Seed and Whitman, 1970). More recent research indicates the location of the resultant of the total earth pressure (static plus seismic) should be located at $h/3$ above the wall base (Clough and Fragaszy, 1977; Al Atik and Sitar, 2010; Bray et al., 2010; and Lew et al., 2010a and b). See Appendix A11 for additional discussion on this issue. As a minimum, the combined resultant of the active and seismic earth pressure (i.e., P_{AE}) should be located no lower, relative to the wall base, than the static earth pressure resultant. However, a slightly higher combined static/seismic resultant location (e.g., $0.4h$ to $0.5h$) may be considered, since there is limited evidence the resultant could be higher, especially for walls in which the impact of failure is relatively high.

Most natural cohesionless soils have some fines content that contributes cohesion, particularly for short-term loading conditions. Similarly, cohesionless backfills are rarely fully saturated and partial saturation provides for some apparent cohesion, even for most clean sands. The effects of cohesion, whether actual or apparent, are an important issue to be considered in practical design problems.

The M-O equation has been extended to $c-\phi$ soils by Prakash and Saran (1966), where solutions were obtained for cases including the effect of tension cracks and wall adhesion. Similar solutions have also been discussed by Richards and Shi (1994) and Chen and Liu (1990).

Results of analyses by Anderson et al. (2008) show a significant reduction in the seismic active pressure for small values of cohesion. From a design perspective, this means that even a small amount of cohesion in the soil could reduce the demand required for retaining wall design.

From a design perspective, the uncertainties in the amount of cohesion or apparent cohesion make it difficult to explicitly incorporate the contributions of cohesion in many situations, particularly in cases where clean backfill materials are being used, regardless of the potential benefits of apparent cohesion that could occur if the soil is partially saturated. Realizing these uncertainties, the following guidelines are suggested.

- Where cohesive soils are being used for backfill or where native soils have a clear cohesive strength component, the designer should give consideration to incorporating some effects of cohesion in the determination of the seismic coefficient.
- If the cohesion in the soil behind the wall results primarily from capillarity stresses, especially in relatively low fines content soils, it is recommended that cohesion be neglected when estimating seismic earth pressure.

The groundwater within the active wedge or submerged conditions (e.g., as in the case of a retaining structure in a harbor or next to a lake or river) can influence the magnitude of the seismic active earth pressure. The time-averaged mean groundwater elevation should be used when assessing groundwater effects.

If the soil within the wedge is fully saturated, then the total unit weight (γ_t) should be used to estimate the earth pressure when using the M-O Method, under the assumption that the soil and water move as a unit during seismic loading. This situation will apply for soils that are not free draining.

If the backfill material is a very open granular material, such as quarry spalls, it is possible that the water will not move with the soil during seismic loading. In this case, the effective unit weight should be used in the pressure determination and an additional force component due to hydrodynamic effects should be added to the wall pressure. Various methods are available to estimate the hydrodynamic pressure (see Kramer, 1996). Generally, these methods involve a form of the Westergaard solution.

11.6.5.4—Calculation of Seismic Earth Pressure for Nonyielding Abutments and Walls

For abutment walls and other walls that are considered nonyielding, the value of k_h used to calculate seismic earth pressure shall be increased to $1.0k_{h0}$, unless the Owner approves the use of more sophisticated numerical analysis techniques to determine the seismically induced earth pressure acting on the wall, considering the ability of the wall to yield in response to lateral loading. In this case, k_h should not be corrected for wall displacement, since displacement is assumed to be zero. However, k_h should be corrected for wave scattering effects as specified in Article 11.6.5.2.2.

C11.6.5.4

The lateral earth pressure calculation methodologies provided in Article 11.6.5.3 assume that the abutment or wall is free to laterally yield a sufficient amount to mobilize peak soil strengths in the backfill. Examples of walls that may be nonyielding are integral abutments, abutment walls with structural wing walls, tunnel portal walls, and tied back cylinder pile walls. For granular soils, peak soil strengths can be assumed to be mobilized if deflections at the wall top are about 0.5 percent of the abutment or wall height. For walls restrained from movement by structures, batter piles, or anchors, lateral forces induced by backfill inertial forces could be greater than those calculated by M-O or GLE methods of analysis. Simplified elastic solutions presented by Wood (1973) for rigid nonyielding walls also indicate that pressures are greater than those given by M-O and GLE analysis. These solutions also indicate that a higher resultant location for the combined effect of static and seismic earth pressure of $h/2$ may be warranted for nonyielding abutments and walls and should be

11.6.5.5—Calculation of Seismic Passive Earth Pressure

For estimating seismic passive earth pressures, wall friction and the deformation required to mobilize the passive resistance shall be considered and a log spiral design methodology shall be used. The M-O Method shall not be used for estimating passive seismic earth pressure.

Seismic passive earth pressures shall be estimated using procedures that account for the friction between the retaining wall and the soil, the nonlinear failure surface that develops in the soil during passive pressure loading, and for wall embedment greater than or equal to 5.0 ft, the inertial forces in the passive pressure zone in front of the wall from the earthquake. For wall embedment depths less than 5.0 ft, passive pressure should be calculated using the static methods provided in Section 3.

In the absence of any specific guidance or research results for seismic loading, a wall interface friction equal to two-thirds of the soil friction angle should be used when calculating seismic passive pressures.

considered for design. The use of a factor of 1.0 applied to k_{h0} is recommended for design where doubt exists that an abutment or wall can yield sufficiently to mobilize backfill soil strengths. In general, if the lack of ability of the wall to yield requires that the wall be designed for K_0 conditions for the strength limit state, then a k_h of $1.0k_{h0}$ should be used for seismic design.

Alternatively, numerical methods may be used to better quantify the yielding or nonyielding nature of the wall and its effect on the seismic earth pressures that develop, if approved by the Owner.

C11.6.5.5

The seismic passive earth pressure becomes important for walls that develop resistance to sliding from the embedded portion of the wall. For these designs, it is important to estimate passive pressures that are not overly conservative or unconservative for the seismic loading condition. This is particularly the case if displacement-based design methods are used but it can also affect the efficiency of designs based on limit-equilibrium methods.

If the depth of embedment of the retaining wall is less than 5.0 ft, the passive pressure can be estimated using static methods given in Section 3 of these Specifications. For this depth of embedment, the inertial effects from earthquake loading on the development of passive pressures will be small.

For greater depths of embedment, the inertial effects of ground shaking on the development of passive pressures should be considered. This passive zone typically extends three to five times the embedment depth beyond the face of the embedded wall.

Shamsabadi et al. (2007) have developed a methodology for estimating the seismic passive pressures while accounting for wall friction and the nonlinear failure surface within the soil. Appendix A11 of this Section provides charts based on this development for a wall friction of two-thirds of the soil friction angle (ϕ) and a range of seismic coefficients, ϕ values, and soil cohesion (c).

The seismic coefficient used in the passive seismic earth pressure calculation is the same value as used for the seismic active earth pressure calculation. Wave scattering reductions are also appropriate to account for incoherency of ground motions in the soil if the depth of the passive zone exceeds 20.0 ft. For most wall designs the difference between the seismic coefficient behind the wall relative to seismic coefficient of the soil in front of the wall is too small to warrant use of different values.

The M-O equation for seismic passive earth pressure is not recommended for use in determining the seismic passive pressure, despite its apparent simplicity. For passive earth pressure determination, the M-O equation is based on the Coulomb method of determining passive earth pressure; this method can overestimate the earth pressure in some cases.

A key consideration during the determination of static and seismic passive pressures is the wall friction. Common practice is to assume that some wall friction will occur for static loading. The amount of interface friction for static loading is often assumed to range from 50 percent to 80 percent of the soil friction angle. Similar guidance is not available for seismic loading.

Another important consideration when using the seismic passive earth pressure is the amount of deformation required to mobilize this force. The deformation to mobilize the passive earth pressure during static loading is usually assumed to be large—typically 2 percent to 6 percent of the embedded wall height. Similar guidance is not available for seismic loading and therefore the normal approach during design for seismic passive earth pressures is to assume that the displacement to mobilize the seismic passive earth pressure is the same as for static loading.

11.6.5.6—Wall Details for Improved Seismic Performance

Details that should be addressed for gravity and semigravity walls in seismically active areas, defined as Seismic Zone 2 or higher, or a peak ground acceleration A_s greater than 0.15g, include the following:

- Vertical Slip Joints, Expansion Joints, and Vertical Joints between an Abutment Curtain Wall and the Free-Standing Wall: Design to prevent joint from opening up and allowing wall backfill to flow through the open joint without sacrificing the joint's ability to slip to allow differential vertical movement. This also applies to joints at wall corners. Compressible joint fillers, bearing pads, and sealants should be used to minimize damage to facing units due to shaking. The joint should also be designed in a way that allows a minimum amount of relative movement between the adjacent facing units to prevent stress build-up between facing units during shaking (Extreme Event I), as well as due to differential deformation between adjacent wall sections at the joint for the service and strength limit states.
- *Coping at Wall Top*: Should be used to prevent toppling of top facing units and excessive differential lateral movement of the facing.
- *Wall Corners and Abrupt Facing Alignment Changes*: Should be designed for the potential for higher loads to develop during shaking than would be determined using two-dimensional analysis. Wall corners and short radius turns are defined as having an enclosed angle of 120 degrees or less.
- *Wall Backfill Stability*: Backfill should be well graded and angular enough to interlock/bind together well to minimize risk of fill spilling

C11.6.5.6

These recommended details are based on previous experiences with walls in earthquakes (e.g., Yen et al., 2011). Walls that did not utilize these details tended to have a higher frequency of problems than walls that did utilize these details.

With regard to preventing joints from opening up during shaking, this can be addressed through use of a backup panel placed behind the joint, a slip joint cover placed in front of the joint, or the placement of the geotextile strip behind the facing panels to bridge across the joint. The special units should allow differential vertical movement between facing units to occur while maintaining the functionality of the joint. The amount of overlap between these joint elements and the adjacent facing units is determined based on the amount of relative movement between facing units that is anticipated in much the same way that the bridge seat width is determined for bridges.

Little guidance on the amount of overlap between the backing panel and the facing panels is available for walls but past practice has been to provide a minimum overlap of 2.0 to 4.0 in. A geotextile strip may also be placed between the backfill soil and the joint or joint and backing panel combination. Typical practice has been to use a minimum overlap of the geotextile beyond the edges of the joint of 6.0 to 9.0 in. and the geotextile is usually attached to the back of the panel using adhesive. Typically, a Class 1 or Class 2 high elongation (>50 percent strain at peak strength) drainage geotextile in accordance with AASHTO M 288 is used. Similarly, this technique may be applied to the joint between the facing units and protrusions through the wall facing.

For wall corners, not cast monolithically, a special facing unit formed to go across the corner, providing overlap with adjacent panels, should be used. Regarding the design of wall corners and abrupt changes in the facing alignment, both static and seismic earth pressure

through open wall joints.

- *Wall Backfill Silt and Clay Content:* Wall backfills classified as a silt or clay should in general not be used in seismically active areas.
- *Structures and Foundations within the Wall Active Zone:* The effect of these structures and foundations on the wall seismic loading shall be evaluated and the wall designed to take the additional load.
- *Protrusions through the Wall Face:* The additional seismic force transmitted to the wall, especially the facing, through the protruding structure (e.g., a culvert or drainage pipe) shall be evaluated. The effect of differential deformation between the protrusion and the wall face shall also be considered. Forces transmitted to the wall face by the protruding structure should be reduced through the use of compressible joint filler or bearing pads and sealant.

loading may be greater than what would be determined from two-dimensional analysis. Historically, corners and abrupt alignment changes in walls have had a higher incidence of performance problems during earthquakes than relatively straight sections of the wall alignment, as the corners tend to attract dynamic load and increased earth pressures. This should be considered when designing a wall corner for seismic loading.

Note that the corner or abrupt alignment change enclosed angle as defined in the previous paragraph can either be internal or external to the wall.

With regard to wall backfill materials, walls that have used compacted backfills with high silt or clay content have historically exhibited more performance problems during earthquakes than those that have utilized compacted granular backfills. This has especially been an issue if the wall backfill does not have adequate drainage features to keep water out of the backfill and the backfill fully drained. Also, very uniform clean sand backfill, especially if it lacks angularity, has also been problematic with regard to wall seismic performance. The issue is how well it can be compacted and remain in a compacted state. A backfill soil coefficient of uniformity of greater than 4 is recommended and, in general, the backfill particles should be classified as subangular or angular rather than rounded or subrounded. The less angular the backfill particles, the more well graded the backfill material needs to be.

For additional information on good wall details, see Berg et al. (2009). While this reference is focused on MSE wall details, similar details could be adapted for gravity and semigravity walls.

11.6.6—Drainage

Backfills behind abutments and retaining walls shall be drained or, if drainage cannot be provided, the abutment or wall shall be designed for loads due to earth pressure, plus full hydrostatic pressure due to water in the backfill.

C11.6.6

Weep holes or geocomposite panel drains at the wall face do not assure fully drained conditions. Drainage systems should be designed to completely drain the entire retained soil volume behind the retaining wall face.

11.7—PIERS

11.7.1—Load Effects in Piers

Piers shall be designed to transmit the loads on the superstructure, and the loads acting on the pier itself, onto the foundation. The loads and load combinations shall be as specified in Section 3.

The structural design of piers shall be in accordance with the provisions of Sections 5, 6, 7, and 8, as appropriate.

11.7.2—Pier Protection

11.7.2.1—Collision

Where the possibility of collision exists from highway or river traffic, an appropriate risk analysis should be made to determine the degree of impact resistance to be provided and/or the appropriate protection system. Collision loads shall be determined as specified in Articles 3.6.5 and 3.14.

11.7.2.2—Collision Walls

Collision walls may be required by railroad owners if the pier is in close proximity to the railroad.

11.7.2.3—Scour

The scour potential shall be determined and the design shall be developed to minimize failure from this condition as specified in Article 2.6.4.4.2.

11.7.2.4—Facing

Where appropriate, the pier nose should be designed to effectively break up or deflect floating ice or drift.

11.8—NONGRAVITY CANTILEVERED WALLS

11.8.1—General

Nongravity cantilevered walls may be considered for temporary and permanent support of stable and unstable soil and rock masses. The feasibility of using a nongravity cantilevered wall at a particular location shall be based on the suitability of soil and rock conditions within the depth of vertical element embedment to support the wall.

11.8.2—Loading

The provisions of Article 11.6.1.2 shall apply. The load factor for lateral earth pressure (*EH*) shall be applied to the lateral earth pressures for the design of nongravity cantilevered walls.

11.8.3—Movement and Stability at the Service Limit State

11.8.3.1—Movement

The provisions of Articles 10.7.2.2 and 10.8.2.1 shall apply. The effects of wall movements on adjacent facilities shall be considered in the selection of the design earth pressures in accordance with the provisions of Article 3.11.1.

C11.7.2.2

Collision walls are usually required by the railroad owner if the column is within 25.0 ft of the rail. Some railroad owners require a collision wall 6.5 ft above the top of the rail between columns for railroad overpasses.

C11.7.2.4

In these situations, pier life can be extended by facing the nosing with steel plates or angles, and by facing the pier with granite.

C11.8.1

Depending on soil conditions, nongravity cantilevered walls less than about 15 ft in height are usually feasible, with the exception of cylinder or tangent pile walls, where greater heights can be used.

C11.8.2

Lateral earth pressure distributions for design of nongravity cantilevered walls are provided in Article 3.11.5.6.

C11.8.3.1

Table C3.11.1-1 provides approximate magnitudes of relative movements required to achieve active earth pressure conditions in the retained soil and passive earth pressure conditions in the resisting soil.

11.8.3.2—Overall Stability

The provisions of Article 11.6.2.3 shall apply.

11.8.4—Safety against Soil Failure at the Strength Limit State**11.8.4.1—Overall Stability**

The provisions of Article 11.6.2.3 shall apply.

The provisions of Article 11.6.3.5 shall apply.

Vertical elements shall be designed to support the full design earth, surcharge and water pressures between the elements. In determining the embedment depth to mobilize passive resistance, consideration shall be given to planes of weakness, e.g., slickensides, bedding planes, and joint sets that could reduce the strength of the soil or rock determined by field or laboratory tests. Embedment in intact rock, including massive to appreciably jointed rock which should not fail through a joint surface, shall be based on the shear strength of the rock mass.

C11.8.3.2

Use of vertical wall elements to provide resistance against overall stability failure is described in Article C11.9.3.2. Discrete vertical elements penetrating across deep failure planes can provide resistance against overall stability failure. The magnitude of resistance will depend on the size, type, and spacing of the vertical elements.

C11.8.4.1

Discrete vertical elements penetrating across deep failure planes can provide resistance against failure. The magnitude of resistance will depend on the size, type, and spacing of vertical elements.

The maximum spacing between vertical supporting elements depends on the relative stiffness of the vertical elements. Spans of 6.0 to 10.0 ft are typical, depending on the type and size of facing.

In determining the embedment depth of vertical wall elements, consideration should be given to the presence of planes of weakness in the soil or rock that could result in a reduction of passive resistance. For laminated, jointed, or fractured soils and rocks, the residual strength along planes of weakness should be considered in the design and, where the planes are oriented at other than an angle of (45 degrees – $\phi'_f/2$) from the horizontal in soil or 45 degrees from the horizontal in rock toward the excavation, the orientation of the planes should also be considered. Where the wall is located on a bench above a deeper excavation, consideration should be given to the potential for bearing failure of a supporting wedge of soil or rock through intact materials along planes of weakness.

In designing permanent nongravity cantilevered walls with continuous vertical elements, the simplified earth pressure distributions in Figure 3.11.5.6-3 may be used with the following procedure (Teng, 1962):

- Determine the magnitude of lateral pressure on the wall due to earth pressure, surcharge loads and differential water pressure over the design height of the wall using k_{a1} .
- Determine the magnitude of lateral pressure on the wall due to earth pressure, surcharge loads and differential water pressure over the design height of the wall using k_{a2} .
- Determine in the following equation the value x as defined in Figure 3.11.5.6-3 to determine the distribution of net passive pressure in front of the wall below the design height:

$$x = [\gamma k_{a2} \gamma'_{s1} H] / \left[(\phi k_{p2} - \gamma k_{a2}) \gamma'_{s2} \right] \quad (\text{C11.8.4.1-1})$$

where:

γ = load factor for horizontal earth pressure, EH (dim.)

k_{a2} = the active earth pressure coefficient for soil 2 (dim.)

γ'_{s1} = the effective soil unit weight for soil 1 (kcf)

H = the design height of the wall (ft)

ϕ = the resistance factor for passive resistance in front of the wall (dim.)

k_{p2} = the passive earth pressure coefficient for soil 2 (dim.)

γ'_{s2} = the effective soil unit weight for soil 2 (kcf)

- Sum moments about the point of action of F (the base of the wall) to determine the embedment (D_o) for which the net passive pressure is sufficient to provide moment equilibrium.
- Determine the depth at which the shear in the wall is zero, i.e., the point at which the areas of the driving and resisting pressure diagrams are equivalent.
- Calculate the maximum bending moment at the point of zero shear.
- Calculate the design depth, $D = 1.2D_o$, to account for errors inherent in the simplified passive pressure distribution.

11.8.5—Safety against Structural Failure

11.8.5.1—Vertical Wall Elements

Vertical wall elements shall be designed to resist all horizontal earth pressure, surcharge, water pressure, and earthquake loadings.

C11.8.5.1

Discrete vertical wall elements include driven piles, drilled shafts, and auger-cast piles, i.e., piles and built-up sections installed in preaugered holes.

Continuous vertical wall elements are continuous throughout both their length and width, although vertical joints may prevent shear and/or moment transfer between adjacent sections. Continuous vertical wall elements include sheet piles, precast or cast-in-place concrete diaphragm wall panels, tangent-piles, and tangent drilled shafts.

The maximum bending moments and shears in vertical wall elements may be determined using the loading diagrams in Article 3.11.5.6, and appropriate load and resistance factors.

11.8.5.2—Facing

The maximum spacing between discrete vertical wall elements shall be determined based on the relative stiffness of the vertical elements and facing, the type and condition of soil to be supported, and the type and condition of the soil in which the vertical wall elements are embedded. Facing may be designed assuming simple support between elements, with or without soil arching, or assuming continuous support over several elements.

C11.8.5.2

In lieu of other suitable methods, for preliminary design the maximum bending moments in facing may be determined as follows:

- For simple spans without soil arching:

$$M_{max} = 0.125 pL^2 \quad (C11.8.5.2-1)$$

If timber facing is used, it shall be stress-grade pressure-treated lumber in conformance with Section 8. If timber is used where conditions are favorable for the growth of decay-producing organisms, wood should be pressure-treated with a wood preservative unless the heartwood of a naturally decay-resistant species is available and is considered adequate with respect to the decay hazard and expected service life of the structure.

- For simple spans with soil arching:

$$M_{max} = 0.083 pL^2 \quad (C11.8.5.2-2)$$

- For continuous spans without soil arching:

$$M_{max} = 0.1 pL^2 \quad (C11.8.5.2-3)$$

- For continuous spans with soil arching:

$$M_{max} = 0.083 pL^2 \quad (C11.8.5.2-4)$$

where:

- M_{max} = factored flexural moment on a unit width or height of facing (kip-ft/ft)
- p = average factored lateral pressure, including earth, surcharge and water pressure acting on the section of facing being considered (ksf/ft)
- L = spacing between vertical elements or other facing supports (ft)

If the variations in lateral pressure with depth are large, moment diagrams should be constructed to provide more accuracy. The facing design may be varied with depth.

Eq. C11.8.5.2-1 is applicable for simply supported facing behind which the soil will not arch between vertical supports, e.g., in soft cohesive soils or for rigid concrete facing placed tightly against the in-place soil. Eq. C11.8.5.2-2 is applicable for simply supported facing behind which the soil will arch between vertical supports, e.g., in granular or stiff cohesive soils with flexible facing or rigid facing behind which there is sufficient space to permit the in-place soil to arch. Eqs. C11.8.5.2-3 and C11.8.5.2-4 are applicable for facing which is continuous over several vertical supports, e.g., reinforced shotcrete or concrete.

11.8.6—Seismic Design of Nongravity Cantilever Walls

11.8.6.1—General

The effect of earthquake loading shall be investigated using the Extreme Event I limit state of Table 3.4.1-1 with resistance factor $\phi=1.0$ and load factor $\gamma_p=1.0$ and an accepted methodology, with the exception of overall stability of the wall, in which case a resistance factor of 0.9 should be used as specified in Article 11.5.8.

The seismic analysis of the nongravity cantilever retaining wall shall demonstrate that the cantilever wall will maintain overall stability and withstand the seismic earth pressures induced by the design earthquake without excessive structural moments and shear on the cantilever wall section. Limit equilibrium methods or numerical displacement analyses shall be used to confirm acceptable wall performance.

Design checks should also be performed for failures below the excavation level but through the structure. These analyses should include the contributions of the structural section to slope stability. If the structural contribution to resistance is being accounted for in the stability assessment, the moments and shears developed by the structural section should be checked to confirm that specified structural limits are not exceeded.

11.8.6.2—Seismic Active Lateral Earth Pressure

Lateral earth pressures and inertial forces for seismic design of nongravity cantilever walls shall be determined as specified in Article 11.6.5. The resulting active seismic earth pressure shall be distributed as specified in Article 11.6.5.3, above the excavation level as shown in Figure 11.8.6.2-1.

To reduce the lateral seismic acceleration coefficient k_{h0} for the effects of horizontal wall displacement in accordance with Article 11.6.5.2.2, analyses shall demonstrate that the displacements associated with the yield acceleration do not result in any of the following:

C11.8.6.1

During seismic loading, the nongravity cantilever wall develops resistance to load through the passive resistance of the soil below the excavation depth. The stiffness of the structural wall section above the excavation depth must be sufficient to transfer seismic forces from the soil behind the wall, through the structural section, to the soil below. The seismic evaluation of the nongravity cantilever wall requires, therefore, determination of the demand on the wall from the seismic active earth pressure and the capacity of the soil from the seismic passive soil resistance.

For flexible cantilevered walls, forces resulting from wall inertia effects may be ignored in estimating the seismic design forces. However, for very massive nongravity cantilever wall systems, such as tangent or secant pile walls, wall mass inertia effects should be included in the seismic analysis of the wall.

Two types of stability checks are conducted for the nongravity cantilever wall: global stability and internal stability. In contrast to gravity and semigravity walls, sliding, overturning, and bearing stability are not design considerations for this wall type. By sizing the wall to meet earth pressures, the equilibrium requirements for external stability are also satisfied.

The global stability check for seismic loading involves a general slope failure analysis that extends below the base of the wall. Typically, the embedment depth of the wall is 1.5 to 2 times the wall height above the excavation level. For these depths, global stability is not normally a concern, except where soft layers are present below the toe of the wall.

The global stability analysis is performed with a slope stability program. The failure surfaces used in the analysis should normally extend below the depth of the structure member.

Internal stability for a nongravity cantilever wall refers to the moments and shear forces developed in the wall from the seismic loads.

C11.8.6.2

In most situations, the nongravity cantilever wall moves enough during seismic loading to develop seismic active earth pressures; however, the amount of movement may not be the 1.0 to 2.0 in. necessary to allow reduction in the seismic coefficient by 50 percent, unless analyses demonstrate that permanent wall movements will occur without damaging the wall components. Beam-column analyses involving p - y modeling of the vertical wall elements will usually be required to make this assessment.

If the effect of cohesion in reducing the seismic active earth pressure acting on the wall is considered,

- Yield of structural members making up the wall, such as with a pile-supported wall,
- Loads applied to the lateral support systems (e.g., ground anchors in anchored wall systems; see Article 11.9.6) that exceed the available factored resistance, and
- Unacceptable deformation or damage to any facilities located in the vicinity of the wall.

the reduction in earth pressure due to cohesion should not be combined with a reduction in earth pressure due to horizontal wall displacement.

As described in Article 11.6.5.3, an alternate approach for determining the seismic active earth pressure involves use of the generalized limit equilibrium method. If used for the design of a nongravity cantilever wall, the geometry of the slope stability model should extend from the ground surface to the bottom or toe of the sheet pile or other nongravity cantilever walls in which the wall is continuous both above and below the excavation line in front of the wall. For soldier pile walls, the analysis extends to the excavation level. The seismic active pressure is determined as described in Appendix A11.

The static lateral earth pressure force acting behind the wall is already included in P_{AE} (i.e., P_{AE} is the combination of the static and seismic lateral earth pressure). See Articles 3.11.6.3 and 11.10.10.1 for definition of terms in Figure 11.8.6.2-1 not specifically defined in this Article.

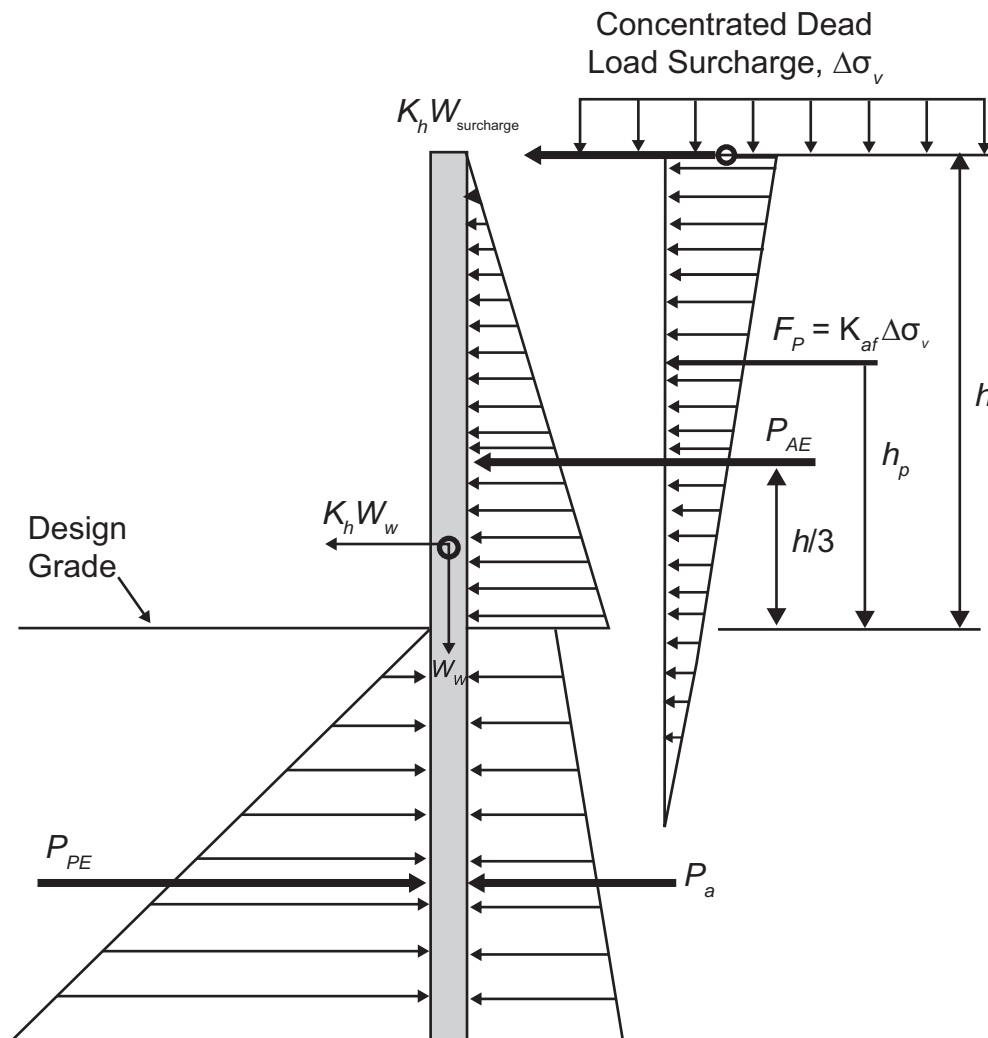

Figure 11.8.6.2-1—Seismic Force Diagram for Nongravity Cantilever Wall External Stability Evaluation

11.8.6.3—Seismic Passive Lateral Earth Pressure

The method used to compute the seismic passive pressure shall consider wall interface friction, the nonlinear failure surface that develops during passive pressure loading, and the inertial response of the soil within the passive pressure wedge for depths greater than 5.0 ft. Cohesion and frictional properties of the soil shall be included in the determination. Passive pressure under seismic loading shall be determined as specified in Article 11.6.5.5.

In the absence of any specific guidance or research results for seismic loading, a wall interface friction equal to two-thirds of the soil friction angle should be used when calculating seismic passive pressures.

The seismic passive pressure shall be applied as a triangular pressure distribution similar to that for static loading. The amount of displacement to mobilize the passive pressure shall also be considered in the analyses.

The peak seismic passive pressure should be based on:

- The time-averaged mean groundwater elevation,
- The full depth of the below-ground structural element, not neglecting the upper 2.0 ft of soil as typically done for static analyses,
- The strength of the soil for undrained loading, and
- The wall friction in the passive pressure estimate taken as two-thirds times the soil strength parameters from a total stress analysis.

In the absence of specific guidance for seismic loading, a reduction factor of 0.67 should be applied to the seismic passive pressure during the seismic check to limit displacement required to mobilize the passive earth pressure.

C11.8.6.3

The effects of live loads are usually neglected in the computation of seismic passive pressure.

Reductions in the seismic passive earth pressure may be warranted to limit the amount of deformation required to mobilize the seismic passive earth pressure, if a limit equilibrium method of analysis is used, to make sure that the wall movement does not result in the collapse of the wall or of structures directly supported by the wall. However, a passive resistance reduction factor near 1.0 may be considered if, in the judgment of the engineer, such deformations to mobilize the passive resistance would not result in wall or supported structure collapse.

If the nongravity cantilever wall uses soldier piles to develop reaction to active pressures, adjustments must be made in the passive earth pressure determination to account for the three-dimensional effects below the excavation level as soil reactions are developed. In the absence of specific seismic studies dealing with this issue, it is suggested that methods used for static loading be adopted. One such method, documented in the California Department of Transportation (Caltrans) *Shoring Manual* (2010), suggests that soldier piles located closer than three pile diameters be treated as a continuous wall. For soldier piles spaced at greater distances, the approach in the *Shoring Manual* depends on the type of soil:

- For cohesive soils, the effective pile width that accounts for arching ranges from one pile diameter for very soft soil to two diameters for stiff soils.
- For cohesionless soils, the effective width is defined as $0.08\phi B$ up to three pile diameters. In this relationship, ϕ is the soil friction angle and B is the soldier pile width.

During seismic loading, the inertial response of the soil within the passive pressure failure wedge will decrease the soil resistance during a portion of each loading cycle. Figures provided in Appendix A11 can be used to estimate the passive soil resistance for different friction values and normalized values of cohesion. A preferred methodology for computing seismic earth pressures with consideration of wall friction, nonlinear soil failure surface, and inertial effects involves use of the procedures documented by Shamsabadi et al. (2007).

11.8.6.4—Wall Displacement Analyses to Determine Earth Pressures

Numerical displacement analyses, if used, shall show that moments, shear forces, and structural displacements resulting from the peak ground surface accelerations are within acceptable levels. These analyses shall be conducted using a model of the wall system that includes the structural stiffness of the wall section, as well as the load displacement response of the soil above and below the excavation level.

C11.8.6.4

Numerical displacement methods offer a more accurate and preferred method of determining the response of nongravity cantilever walls during seismic loading. Either of two numerical approaches can be used. One involves a simple beam-column approach; the second involves the use of a two-dimensional computer model. Both approaches need to appropriately represent the load displacement behavior of the soil and the structural members during loading. For soils, this includes nonlinear stress-strain effects; for structural members, consideration must be given to ductility of the structure, including the use of cracked versus uncracked section properties if concrete structures are being used.

Beam-Column Approach

The pseudostatic seismic response of a nongravity cantilever wall can be determined by representing the wall in a beam-column model with the soil characterized by p - y springs. This approach is available within commercially available computer software. The total seismic active pressure above the excavation level is used for wall loading. Procedures given in Article 11.8.6.2 should be used to make this estimate.

For this approach, the p - y curves below the excavation level need to be specified. For discrete structural elements (e.g., soldier piles), conventional p - y curves for piles may be used. For continuous walls or walls with pile elements at closer than 3 diameter spacing, p - and y -modifiers have been developed by Anderson et al. (2008) to represent a continuous (sheet pile or secant pile) retaining wall. The procedure involves:

- Developing conventional isolated pile p - y curves using a 4.0-ft diameter pile following API (1993) procedures for sands or clays.
- Normalizing the isolated p - y curves by dividing the p values by 4.0 ft.
- Applying the following p - and y -multipliers, depending on the type of soil, in a conventional beam-column analysis.

Soil Type	p -multiplier	y -multiplier
Sand	0.5	4.0
Clay	1.0	4.0

It should be noted that the starting point of using a 4.0 ft diameter pile has nothing to do with the actual diameter of the vertical elements in the wall. It is simply a starting point in the procedure to obtain p - y curves that are applicable to a wall. The p - y curves obtained in the final step of this process are intended to be applicable to a continuous wall.

Supporting information for the development and use of the p - y approach identified above is presented in Volume 1 of NCHRP 611 Report (Anderson et al., 2008). The earth pressure used as the load in the beam column analysis is determined from one of the limit equilibrium methods, including M-O with or without cohesion or the generalized limit equilibrium procedure, as discussed in Article 11.6.5. The benefit of the p - y approach is that it enforces compatibility of deflections, earth pressure, and flexibility of the wall system. The method is in contrast to the limit equilibrium method in which the effects of the wall flexibilities are ignored. This is very important for the seismic design and performance of the wall during seismic event. The deformation and rotation of the wall can easily be captured using the p - y approach.

Finite Difference or Finite Element Modeling

Pseudostatic or dynamic finite element or finite difference procedures in computer programs can also be used to evaluate the seismic response of nongravity cantilever walls during seismic loading. For two-dimensional models, it may be necessary to “smear” the stiffness of the structural section below the excavation level to adjust the model to an equivalent two-dimensional representation if the below-grade portion of the wall is formed from discrete piles (e.g., soldier piles).

The finite difference or finite element approach to evaluating wall response will involve a number of important assumptions; therefore, this approach should be discussed with and agreed to by the Owner before being adopted. As part of the discussions, the possible limitations and the assumptions being made for the model should be reviewed.

11.8.7—Corrosion Protection

The level and extent of corrosion protection shall be a function of the ground environment and the potential consequences of a wall failure.

C11.8.7

Corrosion protection for piles and miscellaneous hardware and material should be consistent with the design life of the structure.

11.8.8—Drainage

The provisions of Article 3.11.3 shall apply.

Seepage shall be controlled by installation of a drainage medium behind the facing with outlets at or near the base of the wall. Drainage panels shall maintain their drainage characteristics under the design earth pressures and surcharge loadings, and shall extend from the base of the wall to a level 1.0 ft below the top of the wall.

Where thin drainage panels are used behind walls, and saturated or moist soil behind the panels may be subjected to freezing and expansion, either insulation shall be provided on the walls to prevent freezing of the soil, or the wall shall be designed for the pressures exerted on the wall by frozen soil.

11.9—ANCHORED WALLS

11.9.1—General

Anchored walls, whose elements may be proprietary, employ grouted in anchor elements, vertical wall elements and facing.

Anchored walls, illustrated in Figure 11.9.1-1, may be considered for both temporary and permanent support of stable and unstable soil and rock masses.

The feasibility of using an anchored wall at a particular location should be based on the suitability of subsurface soil and rock conditions within the bonded anchor stressing zone.

Where fill is placed behind a wall, either around or above the unbonded length, special designs and construction specifications shall be provided to prevent anchor damage.

C11.8.8

In general, the potential for development of hydrostatic pressures behind walls with discrete vertical elements and lagging is limited due to the presence of openings in the lagging, and the disturbance of soil behind lagging as the wall is constructed. However, the potential for leakage through the wall should not be counted upon where the ground water level exceeds one-third the height of the wall because of the potential for plugging and clogging of openings in the wall with time by migration of soil fines. It is probable that, under such conditions, a wall with continuous vertical elements, i.e., a cutoff wall constructed with a drainage system designed to handle anticipated flows will be required.

Water pressures may be considered reduced in design only if positive drainage, e.g., drainage blanket, geocomposite drainage panels, gravel drains with outlet pipes is provided to prevent buildup of hydrostatic pressure behind the wall. Thin drains at the back of the wall face may not completely relieve hydrostatic pressure and may increase seepage forces on the back of the wall face due to rainwater infiltration, Terzaghi and Peck (1967), and Cedergren (1989). The effectiveness of drainage control measures should be evaluated by seepage analyses.

C11.9.1

Depending on soil conditions, anchors are usually required for support of both temporary and permanent nongravity cantilevered walls higher than about 10.0 to 15.0 ft.

The availability or ability to obtain underground easements and proximity of buried facilities to anchor locations should also be considered in assessing feasibility.

Anchored walls in cuts are typically constructed from the top of the wall down to the base of the wall. Anchored walls in fill must include provisions to protect against anchor damage resulting from backfill and subsoil settlement or backfill and compaction activities above the anchors.

The minimum distance between the front of the bond zone and the active zone behind the wall of 5.0 ft or $H/5$ is needed to insure that no load from the bonded zone is transferred into the no load zone due to load transfer through the grout column in the no load zone.

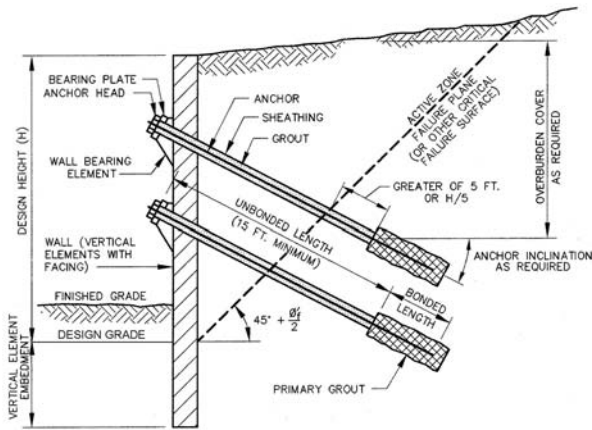

Figure 11.9.1-1—Anchored Wall Nomenclature and Anchor Embedment Guidelines

11.9.2—Loading

The provisions of Article 11.6.1.2 shall apply, except that shrinkage and temperature effects need not be considered.

11.9.3—Movement and Stability at the Service Limit State

11.9.3.1—Movement

The provisions of Articles 10.6.2.2, 10.7.2.2, and 10.8.2.1 shall apply.

The effects of wall movements on adjacent facilities shall be considered in the development of the wall design.

C11.9.2

Lateral earth pressures on anchored walls are a function of the rigidity of the wall-anchor system, soil conditions, method and sequence of construction, and level of prestress imposed by the anchors. Apparent earth pressure diagrams that are commonly used can be found in Article 3.11.5.7 and Sabatini et al. (1999).

C11.9.3.1

Settlement of vertical wall elements can cause reduction of anchor loads, and should be considered in design.

The settlement profiles in Figure C11.9.3.1-1 were recommended by Clough and O'Rourke (1990) to estimate ground surface settlements adjacent to braced or anchored excavations caused during the excavation and bracing stages of construction. Significant settlements may also be caused by other construction activities, e.g., dewatering or deep foundation construction within the excavation, or by poor construction techniques, e.g., soldier pile, lagging, or anchor installation. The field measurements used to develop Figure C11.9.3.1-1 were screened by the authors to not include movements caused by other construction activities or poor construction techniques. Therefore, such movements should be estimated separately.

Where noted in the definition of the various curves in Figure C11.9.3.1-1, the basal heave ratio, RBH, shall be taken as:

$$R_{BH} = \frac{5.1S_u}{\gamma_s H + q_s} \tag{C11.9.3.1-1}$$

where:

- S_u = undrained shear strength of cohesive soil (ksf)
 γ_s = unit weight of soil (kcf)
 H = height of wall (ft)
 q_s = surcharge pressure (ksf)

See Sabatini et al. (1999) for additional information on the effect of anchored wall construction and design on wall movement.

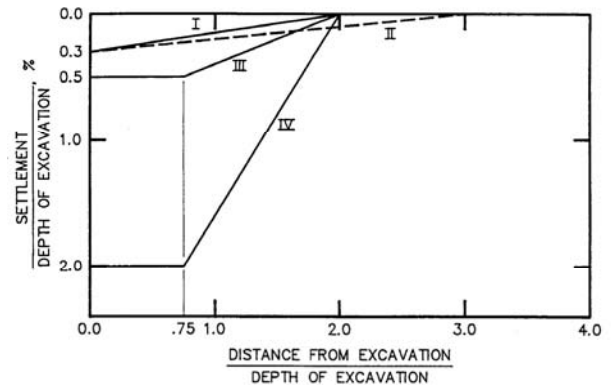

- Curve I = Sand
 Curve II = Stiff to very hard clay
 Curve III = Soft to medium clay, $R_{BH} = 2.0$
 Curve IV = Soft to medium clay, $R_{BH} = 1.2$

Figure C11.9.3.1-1—Settlement Profiles behind Braced or Anchored Walls (adapted from Clough and O'Rourke, 1990)

11.9.3.2—Overall Stability

The provisions of Article 11.6.2.3 shall apply.

C11.9.3.2

Detailed guidance for evaluating the overall stability of anchored wall systems, including how to incorporate anchor forces in limit equilibrium slope stability analyses, is provided by Sabatini et al. (1999).

The effect of discrete vertical elements penetrating deep failure planes and acting as in-situ soil improvement may be negligible if the percentage of reinforcement provided by the vertical elements along the failure surface is small. However, it is possible to consider the effect of the discrete vertical elements by modeling the elements as a cohesion along the failure surface, or by evaluating the passive capacity of the elements.

11.9.4—Safety against Soil Failure

11.9.4.1—Bearing Resistance

The provisions of Articles 10.6.3, 10.7.3, and 10.8.3 shall apply.

Bearing resistance shall be determined assuming that all vertical components of loads are transferred to the embedded section of the vertical wall elements.

C11.9.4.1

For drilled in place vertical wall elements, e.g., drilled-in soldier piles, in sands, if the β -method is used to calculate the skin friction capacity, the depth z should be referenced to the top of the wall. The vertical overburden stress, σ_v' , however, should be calculated with reference to the elevation of the midheight of the exposed wall, with β and σ_v' evaluated at the midpoint of each soil layer.

11.9.4.2—Anchor Pullout Capacity

Prestressed anchors shall be designed to resist pullout of the bonded length in soil or rock. The factored pullout resistance of a straight shaft anchor in soil or rock, Q_R , is determined as:

$$Q_R = \phi Q_n = \phi \pi d \tau_n L_b \tag{11.9.4.2-1}$$

where:

ϕ = resistance factor for anchor pullout (dim.)

Q_n = nominal anchor pullout resistance (kips)

d = diameter of anchor drill hole (ft)

τ_n = nominal anchor bond stress (ksf)

L_b = anchor bond length (ft)

For preliminary design, the resistance of anchors may either be based on the results of anchor pullout load tests; estimated based on a review of geologic and boring data, soil and rock samples, laboratory testing and previous experience; or estimated using published soil/rock-grout bond guidelines. For final design, the contract documents may require preproduction tests such as pullout tests or extended creep tests on sacrificial anchors be conducted to establish anchor lengths and capacities that are consistent with the contractor’s chosen method of anchor installation. Either performance or proof tests shall be conducted on every production anchor to 1.0 or greater times the factored load to verify capacity.

C11.9.4.2

Anchor pullout capacity is influenced by soil and rock conditions, method of anchor hole advancement, hole diameter, bonded length, grout type and grouting pressure. Information on anchor pullout capacity may be found in Sabatini et al. (1999), PTI (1996), Cheney (1984) and Weatherby (1982). As a guide, the presumptive values provided in Tables C11.9.4.2-1, C11.9.4.2-2, and C11.9.4.2-3 may be used to estimate the nominal (ultimate) bond for small diameter anchors installed in cohesive soils, cohesionless soils and rock, respectively. It should be recognized that the values provided in the tables may be conservative.

Table C11.9.4.2-1—Presumptive Ultimate Unit Bond Stress for Anchors in Cohesive Soils

Anchor/Soil Type (Grout Pressure)	Soil Stiffness or Unconfined Compressive Strength (tsf)	Presumptive Ultimate Unit Bond Stress, τ_n (ksf)
Gravity Grouted Anchors (<50 psi)		
Silt-Clay Mixtures	Stiff to Very Stiff 1.0–4.0	0.6 to 1.5
Pressure Grouted Anchors (50 psi–400 psi)		
High Plasticity Clay	Stiff 1.0–2.5 V. Stiff 2.5–4.0	0.6 to 2 1.5 to 3.6
Medium Plasticity Clay	Stiff 1.0–2.5 V. Stiff 2.5–4.0	2.0 to 5.2 2.9 to 7.3
Medium Plasticity Sandy Silt	V. Stiff 2.5–4.0	5.8 to 7.9

Table C11.9.4.2-2—Presumptive Ultimate Unit Bond Stress for Anchors in Cohesionless Soils

Anchor/Soil Type (Grout Pressure)	Soil Compactness or SPT Resistance ^a	Presumptive Ultimate Unit Bond Stress, τ_n (ksf)
Gravity Grouted Anchors (<50 psi)		
Sand or Sand- Gravel Mixtures	Medium Dense to Dense 11–50	1.5 to 2.9
Pressure Grouted Anchors (50 psi– 400 psi)		
Fine to Medium Sand	Medium Dense to Dense 11–50	1.7 to 7.9
Medium to Coarse Sand w/ Gravel	Medium Dense 11–30	2.3 to 14
	Dense to Very Dense 30–50	5.2 to 20
Silty Sands	—	3.5 to 8.5
Sandy Gravel	Medium Dense to Dense 11–40	4.4 to 29
	Dense to Very Dense 40–50+	5.8 to 29
Glacial Till	Dense 31–50	6.3 to 11

^a Corrected for overburden pressure.

Table C11.9.4.2-3—Presumptive Ultimate Unit Bond Stress for Anchors in Rock

Rock Type	Presumptive Ultimate Unit Bond Stress, τ_n (ksf)
Granite or Basalt	36 to 65
Dolomitic Limestone	29 to 44
Soft Limestone	21 to 29
Slates & Hard Shales	17 to 29
Sandstones	17 to 36
Weathered Sandstones	15 to 17
Soft Shales	4.2 to 17

The presumptive ultimate anchor bond stress values presented in Tables C11.9.4.2-1 through C11.9.4.2-3 are intended for preliminary design or evaluation of the feasibility of straight shaft anchors installed in small diameter holes. Pressure-grouted anchors may achieve much higher capacities. The total capacity of a pressure-grouted anchor may exceed 500 kips in soil or 2000 to 3000 kips in rock, although such high capacity anchors are seldom used for highway applications. Post-grouting can also increase the load carrying capacity of straight shaft anchors by 20–50 percent or more per phase of post-grouting.

The resistance factors in Table 11.5.7-1, in combination with the load factor for horizontal active earth pressure (Table 3.4.1-2), are consistent with what would be required based on allowable stress design, for preliminary design of anchors for pullout (Sabatini et al., 1999). These resistance factors are also consistent with the results of statistical calibration of full scale anchor pullout tests relative to the minimum values of presumptive ultimate unit bond stresses shown in Tables C11.9.4.2-1 through C11.9.4.2-3. Use of the resistance factors in Table 11.5.7-1 and the load factor for apparent earth pressure for anchor walls in Table 3.4.1-2, with values of presumptive ultimate unit bond stresses other than the minimum values in Tables C11.9.4.2-1 through C11.9.4.2-3 could result in unconservative designs unless the Engineer has previous experience with the particular soil or rock unit in which the bond zone will be established.

Presumptive bond stresses greater than the minimum values shown in Tables C11.9.4.2-1 through C11.9.4.2-3 should be used with caution, and be based on past successful local experience, such as a high percentage of passing proof tests in the specified or similar soil or rock unit at the design bond stress chosen, or anchor pullout test results in the specified or similar soil or rock unit. Furthermore, in some cases the specified range of presumptive bond stresses is representative of a range of soil conditions. Soil conditions at the upper end of the specified range, especially if coupled with previous experience with the particular soil unit, may be considered in the selection of anchor bond stresses above the minimum values shown. Selection of a presumptive bond stress for preliminary anchor sizing should consider the risk of failing proof tests if the selected bond stress was to be used for final design. The goal of preliminary anchor design is to reduce the risk of having a significant number of production anchors fail proof or performance tests as well as the risk of having to redesign the anchored wall to accommodate more anchors due to an inadequate easement behind the wall, should the anchor capacities predicted during preliminary design not be achievable.

See Article 11.9.8.1 for guidance on anchor testing.

Significant increases in anchor capacity for anchor bond lengths greater than approximately 40.0 ft cannot be achieved unless specialized methods are used to transfer load from the top of the anchor bond zone towards the end of the anchor. This is especially critical for strain sensitive soils, in which residual soil strength is significantly lower than the peak soil strength.

Anchor inclination and spacing will be controlled by soil and rock conditions, the presence of geometric constraints and the required anchor capacity. For tremie-grouted anchors, a minimum angle of inclination of about 10 degrees and a minimum overburden cover of about 15.0 ft are typically required to assure grouting of the entire bonded length and to provide sufficient ground cover above the anchorage zone. For pressure-grouted anchors, the angle of inclination is generally not

The anchor load shall be developed by suitable embedment outside of the critical failure surface in the retained soil mass.

Determination of the unbonded anchor length, inclination, and overburden cover shall consider:

- The location of the critical failure surface furthest from the wall,

- The minimum length required to ensure minimal loss of anchor prestress due to long-term ground movements,
- The depth to adequate anchoring strata, as indicated in Figure 11.9.1-1, and
- The method of anchor installation and grouting.

The minimum horizontal spacing of anchors should be the larger of three times the diameter of the bonded zone, or 5.0 ft. If smaller spacings are required to develop the required load, consideration may be given to differing anchor inclinations between alternating anchors.

11.9.4.3—Passive Resistance

The provisions of Articles 11.6.3.5, 11.6.3.6, and 11.8.4.1 shall apply.

11.9.5—Safety against Structural Failure

11.9.5.1—Anchors

The horizontal component of anchor design force shall be computed using the provisions of Article 11.9.2 and any other horizontal pressure components acting on the wall in Article 3.11. The total anchor design force shall be determined based on the anchor inclination. The horizontal anchor spacing and anchor capacity shall be selected to provide the required total anchor design force.

critical and is governed primarily by geometric constraints, and the minimum overburden cover is typically 6.0–15.0 ft. Steep inclinations may be required to avoid anchorage in unsuitable soil or rock. Special situations may require horizontal or near horizontal anchors, in which case proof of sufficient overburden and full grouting should be required.

The minimum horizontal spacing specified for anchors is intended to reduce stress overlap between adjacent anchors.

Anchors used for walls constructed in fill situations, i.e., bottom-up construction, should be enclosed in protective casing to prevent damage during backfill placement, compaction and settlement.

Selection of anchor type depends on anticipated service life, soil and rock conditions, ground water level, subsurface environmental conditions, and method of construction.

C11.9.4.3

It is recommended in Sabatini et al. (1999) that methods such as the Broms Method or the Wang and Reese method be used to evaluate passive resistance and the wall vertical element embedment depth needed. However, these methods have not been calibrated for this application for LRFD as yet.

C11.9.5.1

Anchor tendons typically consist of steel bars, wires or strands. The selection of anchor type is generally the responsibility of the contractor.

A number of suitable methods for the determination of anchor loads are in common use. Sabatini et al. (1999) provides two methods which can be used: the Tributary Area Method, and the Hinge Method. These methods are illustrated in Figures C11.5.9.1-1 and C11.5.9.1-2. These figures assume that the soil below the base of the excavation has sufficient strength to resist the reaction force R . If the soil providing passive resistance below the base of the excavation is weak and is inadequate to carry the reaction force R , the lowest anchor should be designed to carry both the anchor load as shown in the figures as well as the reaction force. See Article 11.8.4.1 for evaluation of passive resistance. Alternatively, soil-structure interaction analyses, e.g., beam on elastic foundation, can be used to design continuous beams with small toe reactions, as it may be overly conservative to assume that all of the load is carried by the lowest anchor.

In no case should the maximum test load be less than the factored load for the anchor.

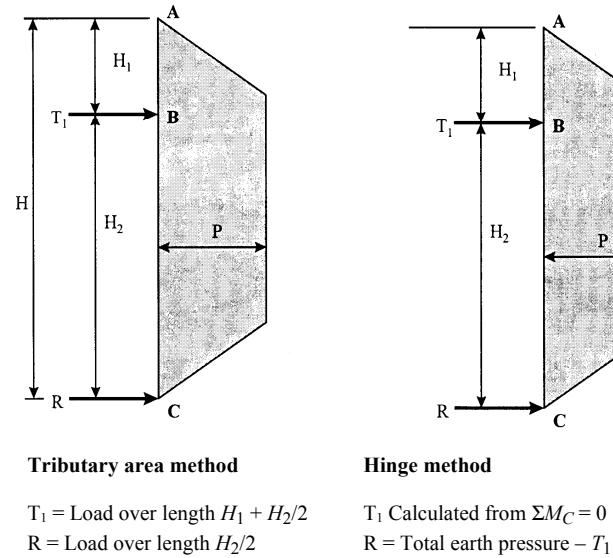

Figure C11.9.5.1-1—Calculation of Anchor Loads for One-Level Wall after Sabatini et al. (1999)

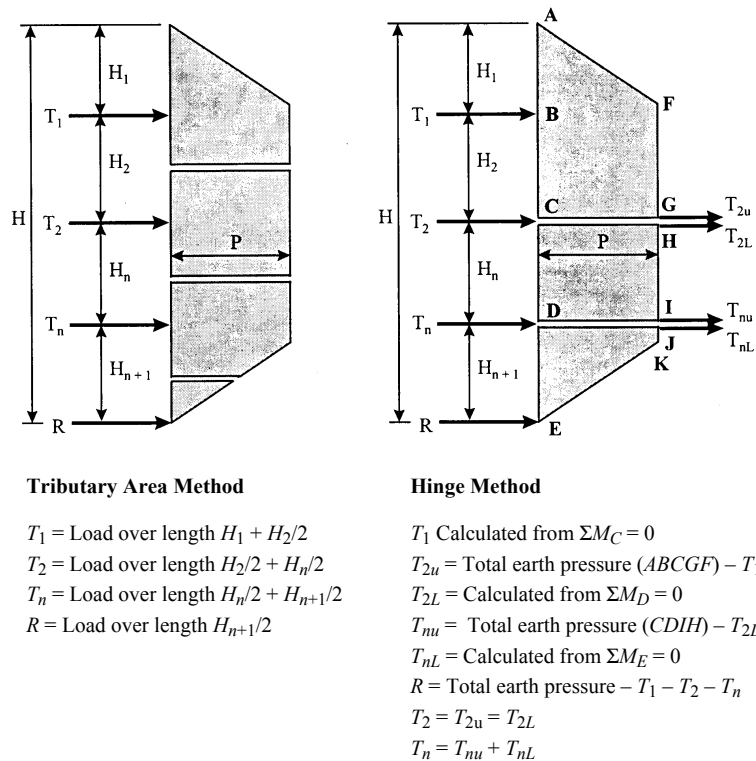

Figure C11.9.5.1-2—Calculation of Anchor Loads for Multilevel Wall after Sabatini et al. (1999)

11.9.5.2—Vertical Wall Elements

Vertical wall elements shall be designed to resist all horizontal earth pressure, surcharge, water pressure, anchor, and seismic loadings, as well as the vertical component of the anchor loads and any other vertical loads. Horizontal supports may be assumed at each anchor location and at the bottom of the excavation if the vertical element is sufficiently embedded below the bottom of the excavation.

11.9.5.3—Facing

The provisions of Article 11.8.5.2 shall apply.

11.9.6—Seismic Design

The provisions of Article 11.8.6 shall apply except as modified in this Article.

The seismic analysis of the anchored retaining wall shall demonstrate that the anchored wall can maintain overall stability and withstand the seismic earth pressures induced by the design earthquake without exceeding the capacity of the anchors or the structural wall section supporting the soil. Limit equilibrium methods or numerical displacement analyses shall be used to confirm acceptable wall performance.

Anchors shall be located behind the limit equilibrium failure surface for seismic loading. The location of the failure surface for seismic loading shall be established using methods that account for the seismic coefficient and the soil properties (i.e., c and ϕ) within the anchored zone.

C11.9.5.2

Discrete vertical wall elements are continuous throughout their length and include driven piles, caissons, drilled shafts, and auger-cast piles, i.e., piles and built-up sections installed in preaugured holes and backfilled with structural concrete in the passive zone and lean concrete in the exposed section of the wall.

Continuous vertical wall elements are continuous throughout both their length and width, although vertical joints may prevent shear and/or moment transfer between adjacent sections. Continuous vertical wall elements include sheet piles, precast or cast-in-place concrete diaphragm wall panels, tangent-piles, and tangent caissons.

For structural analysis methods, see Section 4.

For walls supported in or through soft clays with $S_u < 0.15\gamma'_s H$, continuous vertical elements extending well below the exposed base of the wall may be required to prevent heave in front of the wall. Otherwise, the vertical elements are embedded approximately 3.0 ft or as required for stability or end bearing.

C11.9.6

See Article C11.8.6.

The seismic design of an anchored wall involves many of the same considerations as the nongravity cantilever wall. However, the addition of one or more anchors to the wall introduces some important differences in the seismic design check as identified in this Article.

The earth pressures above the excavation level result from the inertial response of the soil mass behind the wall. In contrast to a nongravity cantilever wall, the soil mass includes anchors that have been tensioned to minimize wall deflections under static earth pressures. During seismic loading, the bars or strands making up the unbonded length of the anchor are able to stretch under the imposed incremental seismic loads. In most cases, the amount of elastic elongation in the strand or bar under the incremental seismic load is sufficient to develop seismic active earth pressures but may not be sufficient to allow the horizontal seismic acceleration coefficient, k_{h0} , and associated earth pressure to be reduced to account for permanent horizontal wall displacement. The ability of the wall to deform laterally should be specifically investigated before reducing k_{h0} to account for horizontal wall displacement.

The passive pressure for the embedded portion of the soldier pile or sheet pile wall also plays a part in the stability assessment, as it helps provide stability for the portion of the wall below the lowest anchor. This passive pressure is subject to seismically induced inertial forces that will reduce the passive resistance relative to

the static capacity of the pile or wall section. Most often, the embedded portion of the pile involves discrete structural members spaced at 8.0 to 10.0 ft; however, the embedded portion could also involve a continuous wall in the case of a sheet pile or secant pile wall.

Anchors should be located behind the failure surface associated with the calculation of P_{AE} . The location of this failure surface can be determined using either the wedge equilibrium or the generalized limit equilibrium (slope stability) method. Note that this failure surface will likely be flatter than the requirements for anchor location under static loading. When using the wedge equilibrium or the generalized limit equilibrium method, P_{AE} and its associated critical surface should be determined without the anchor forces.

Once the location of the anchor bond zone is defined, an external stability check should be conducted with the anchor forces included, using the anchor test load to define ultimate anchor capacities. This check is performed to confirm that the C/D ratio is greater than 1.0. Under this loading condition, the critical surface will flatten and could pass through or behind some anchors. However, as long as the C/D ratio is greater than 1.0, the design is satisfactory.

If the C/D ratio is less than 1.0, either the unbonded length of the anchor must be increased or the length of the grouted zone must be lengthened. The design check would then be repeated.

The global stability check is performed to confirm that a slope stability failure does not occur below the anchored wall; external stability is checked to confirm the anchors will have sufficient reserve capacity to meet seismic load demands; and internal stability is checked to confirm that moments and shear forces within the structural members, including the anchor strand or bar tensile loads and the head connection, are within acceptable levels for the seismic load.

11.9.7—Corrosion Protection

Prestressed anchors and anchor heads shall be protected against corrosion consistent with the ground and groundwater conditions at the site. The level and extent of corrosion protection shall be a function of the ground environment and the potential consequences of an anchor failure. Corrosion protection shall be applied in accordance with the provisions of *AASHTO LRFD Bridge Construction Specifications*, Section 6, “Ground Anchors.”

C11.9.7

Corrosion protection for piles, wales, and miscellaneous hardware and material should be consistent with the level of protection for the anchors and the design life of the structure.

11.9.8—Construction and Installation

11.9.8.1—Anchor Stressing and Testing

All production anchors shall be subjected to load testing and stressing in accordance with the provisions of *AASHTO LRFD Bridge Construction Specifications*, Article 6.5.5, “Testing and Stressing.” Preproduction load tests may be specified when unusual conditions are encountered to verify the safety with respect to the design load to establish the ultimate anchor load (pullout test), or to identify the load at which excessive creep occurs.

At the end of the testing of each production anchor, the anchor should be locked off to take up slack in the anchored wall system to reduce post-construction wall deformation. The lock-off load should be determined and applied as described in *AASHTO LRFD Bridge Construction Specifications*, Article 6.5.5.6.

C11.9.8.1

Common anchor load tests include pullout tests performed on sacrificial preproduction anchors, and creep, performance, and proof tests performed on the production anchors. None of the production anchor tests determine the actual ultimate anchor load capacity. The production anchor test results only provide an indication of serviceability under a specified load. Performance tests consist of incremental loading and unloading of anchors to verify sufficient capacity to resist the test load, verify the free length and evaluate the permanent set of the anchor. Proof tests, usually performed on each production anchor, consist of a single loading and unloading cycle to verify sufficient capacity to resist the test load and to prestress the anchor. Creep tests, recommended for cohesive soils with a plasticity index greater than 20 percent or a liquid limit greater than 50 percent, and highly weathered, soft rocks, consist of incremental, maintained loading of anchors to assess the potential for loss of anchor bond capacity due to ground creep.

Pullout tests should be considered in the following circumstances:

- If the preliminary anchor design using unit bond stresses provided in the tables above indicate that anchored walls are marginally infeasible, requiring that a more accurate estimate of anchor capacity be obtained during wall design. This may occur due to lack of adequate room laterally to accommodate the estimated anchor length within the available right-of-way or easement;
- If the anticipated anchor installation method or soil/rock conditions are significantly different than those assumed to develop the presumptive values in Tables C11.9.4.2-1 through C11.9.4.2-3 and inadequate site specific experience is available to make a reasonably accurate estimate of the soil/rock-grout anchor bond stresses.

The FHWA recommends load testing anchors to 125 percent to 150 percent of the unfactored design load, Cheney (1984). Maximum load levels between 125 percent and 200 percent have been used to evaluate the potential for tendon overstress in service, to accommodate unusual or variable ground conditions or to assess the effect of ground creep on anchor capacity. Test load levels greater than 150 percent of the unfactored design load are normally applied only to anchors in soft cohesive soil or unstable soil masses where loss of anchor prestress due to creep warrants evaluation. The area of prestressing steel in the test anchor tendon may require being increased to perform these tests.

Note that the test details provided in the *AASHTO LRFD Bridge Construction Specifications*, Article 6.5.5, at least with regard to the magnitude of the incremental test loads, were developed for allowable stress design. These incremental test loads should be divided by the load factor for apparent earth pressure for anchored walls provided in Table 3.4.1-2 when testing to factored anchor loads.

Typically, the anchor lock-off load is equal to 80 to 100 percent of the nominal (unfactored) anchor load to ensure that the slack in the anchored wall system is adequately taken up so that post-construction wall deformation is minimized. However, a minimum lock-off load of 50 percent is necessary to properly engage strand anchor head wedges.

11.9.9—Drainage

The provisions of Article 11.8.8 shall apply.

C11.9.9

Thin drains at the back of the wall face may not completely relieve hydrostatic pressure and may increase seepage forces on the back of the wall face due to rainwater infiltration, Terzaghi and Peck (1967), and Cedergren (1989). The effectiveness of drainage control measures should be evaluated by seepage analyses.

11.10—MECHANICALLY STABILIZED EARTH WALLS

11.10.1—General

MSE walls may be considered where conventional gravity, cantilever, or counterforted concrete retaining walls and prefabricated modular retaining walls are considered, and particularly where substantial total and differential settlements are anticipated.

When two intersecting walls form an enclosed angle of 70 degrees or less, the affected portion of the wall shall be designed as an internally tied bin structure with at-rest earth pressure coefficients.

MSE walls shall not be used under the following conditions:

- Where utilities other than highway drainage are to be constructed within the reinforced zone unless access is provided to utilities without disrupting

C11.10.1

Mechanically stabilized earth (MSE) systems, whose elements may be proprietary, employ either metallic (strip or grid type) or geosynthetic (geotextile, strip, or geogrid) tensile reinforcements in the soil mass, and a facing element which is vertical or near vertical. MSE walls behave as a gravity wall, deriving their lateral resistance through the dead weight of the reinforced soil mass behind the facing. For relatively thick facings, the dead weight of the facing may also provide a significant contribution to the capacity of the wall system. Typical MSE walls are shown in Figure C11.10.1-1.

All available data indicates that corrosion in MSE walls is not accelerated by stray currents from electric rail lines due to the discontinuity of the earth reinforcements in a direction parallel to the source of the stray current. Where metallic reinforcements are used in areas of anticipated stray currents within 200 ft of the structure, and the metallic reinforcements are continuously connected in a direction parallel to the source of stray currents, a corrosion expert should evaluate the potential need for corrosion control requirements. More detailed information on stray current corrosion issues is provided by Sankey and Anderson (1999).

Where future access to utilities may be gained without disrupting reinforcements and where leakage from utilities would not create detrimental hydraulic

reinforcements and breakage or rupture of utility lines will not have a detrimental effect on the stability of the structure.

- Where floodplain erosion or scour may undermine the reinforced fill zone or facing, or any supporting footing.
- With reinforcements exposed to surface or ground water contaminated by acid mine drainage, other industrial pollutants, or other environmental conditions defined as aggressive in Article 7.3.6.3 of the *AASHTO LRFD Bridge Construction Specifications*, unless environmental-specific, long-term corrosion, or degradation studies are conducted.

conditions or degrade reinforcements, utilities in the reinforced zone may be acceptable.

The potential for catastrophic failure due to scour is high for MSE walls if the reinforced fill is lost during a scour occurrence. Consideration may be given to lowering the base of the wall or to alternative methods of scour protection, such as sheetpile walls and/or riprap of sufficient size, placed to a sufficient depth to preclude scour.

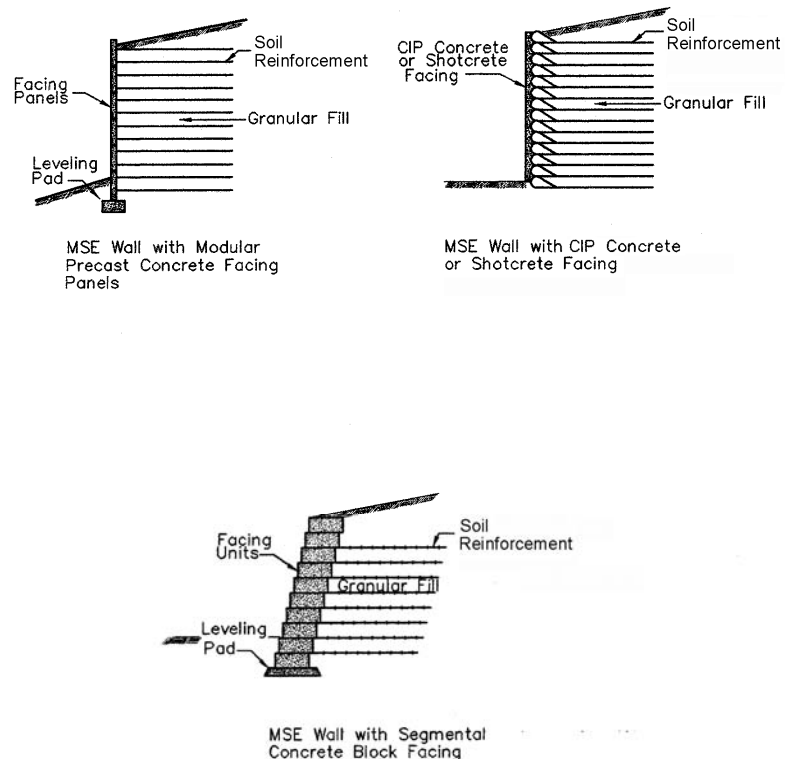

Figure C11.10.1-1—Typical Mechanically Stabilized Earth Walls

MSE walls shall be designed for external stability of the wall system as well as internal stability of the reinforced soil mass behind the facing. Overall and compound stability failure shall be considered. Structural design of the wall facing shall also be considered.

The specifications provided herein for MSE walls do not apply to geometrically complex MSE wall systems such as tiered walls (walls stacked on top of one another), back-to-back walls, or walls which have trapezoidal sections. Design guidelines for these cases are provided in FHWA-NHI-10-024 (Berg et al., 2009).

For simple structures with rectangular geometry, relatively uniform reinforcement spacing, and a near vertical face, compound failures passing both through the unreinforced and reinforced zones will not generally be critical. However, if complex conditions exist such as changes in reinforced soil types or reinforcement lengths, high surcharge loads, sloping faced structures, a slope at the toe of the wall, or stacked structures, compound failures must be considered.

Internal design of MSE wall systems requires knowledge of short- and long-term properties of the

Compound stability should also be evaluated for these complex MSE wall systems (see Article 11.10.4.3).

materials used as soil reinforcements as well as the soil mechanics which govern MSE wall behavior.

11.10.2—Structure Dimensions

An illustration of the MSE wall element dimensions required for design is provided in Figure 11.10.2-1.

The size and embedment depth of the reinforced soil mass shall be determined based on:

- Requirements for stability and geotechnical strength, as specified in Article 11.10.5 consistent with requirements for gravity walls,
- Requirements for structural resistance within the reinforced soil mass itself, as specified in Article 11.10.6, for the panel units, and for the development of reinforcement beyond assumed failure zones, and
- Traditional requirements for reinforcement length not less than 70 percent of the wall height, except as noted in Article 11.10.2.1.

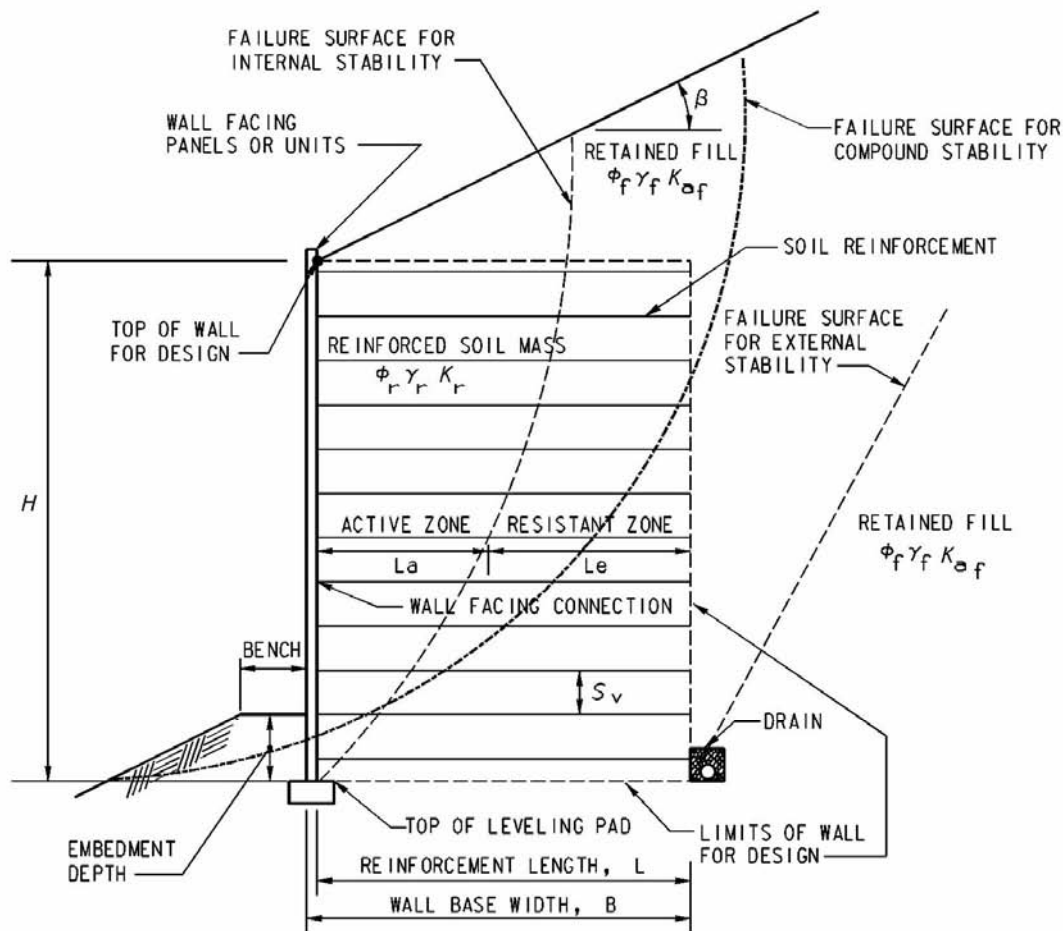

For external and internal stability calculations, the weight and dimensions of the facing elements are typically ignored. However, it is acceptable to include the facing dimensions and weight in sliding and bearing capacity calculations. For internal stability calculations, the wall dimensions are considered to begin at the back of the facing elements.

Figure 11.10.2-1—MSE Wall Element Dimensions Needed for Design

11.10.2.1—Minimum Length of Soil Reinforcement

For sheet-, strip-, and grid-type reinforcement, the minimum soil reinforcement length shall be 70 percent of the wall height as measured from the leveling pad. Reinforcement length shall be increased as required for surcharges and other external loads, or for soft foundation soils.

The reinforcement length shall be uniform throughout the entire height of the wall, unless substantiating evidence is presented to indicate that variation in length is satisfactory.

C11.10.2.1

In general, a minimum reinforcement length of 8.0 ft, regardless of wall height, has been recommended based on historical practice, primarily due to size limitations of conventional spreading and compaction equipment. Shorter minimum reinforcement lengths, on the order of 6.0 ft, but no less than 70 percent of the wall height, can be considered if smaller compaction equipment is used, facing panel alignment can be maintained, and minimum requirements for wall external stability are met.

The requirement for uniform reinforcement length equal to 70 percent of the structure height has no theoretical justification, but has been the basis of many successful designs to-date. Parametric studies considering minimum acceptable soil strengths have shown that structure dimensions satisfying all of the requirements of Article 11.10.5 require length to height ratios varying from $0.8H$ for low structures, i.e., 10.0 ft, to $0.63H$ for high structures, i.e., 40.0 ft.

Significant shortening of the reinforcement elements below the minimum recommended ratio of $0.7H$ may only be considered when accurate, site specific determinations of the strength of the unreinforced fill and the foundation soil have been made. Christopher et al. (1990) presents results which strongly suggest that shorter reinforcing length to height ratios, i.e., $0.5H$ to $0.6H$, substantially increase horizontal deformations.

A nonuniform reinforcement length may be considered under the following circumstances:

- Lengthening of the uppermost reinforcement layers to beyond $0.7H$ to meet pullout requirements, or to address seismic or impact loads.
- Lengthening of the lowermost reinforcement layers beyond $0.7H$ to meet overall (global) stability requirements based on the results of a detailed global stability analysis.
- Shortening of the bottom reinforcement layers to less than $0.7H$ to minimize excavation requirements, provided the wall is bearing on rock or very competent foundation soil (see below).

For walls on rock or very competent foundation soil, e.g., SPT > 50, the bottom reinforcements may be shortened to a minimum of $0.4H$ with the upper reinforcements lengthened to compensate for external stability issues in lieu of removing rock or competent soil for construction. Design guidelines for this case are provided in FHWA-NHI-10-024 (Berg et al., 2009).

For conditions of marginal stability, consideration must be given to ground improvement techniques to improve foundation stability, or to lengthening of reinforcement.

11.10.2.2—Minimum Front Face Embedment

The minimum embedment depth of the bottom of the reinforced soil mass (top of the leveling pad) shall be based on bearing resistance, settlement, and stability requirements determined in accordance with Section 10.

Unless constructed on rock foundations, the embedment at the front face of the wall in ft shall not be less than:

- a depth based on the prevailing depth of frost penetration, if the soil below the wall is frost susceptible, and the external stability requirement, and
- 2.0 ft on sloping ground (4.0H:1V or steeper) or where there is potential for removal of the soil in front of the wall toe due to erosion or future excavation, or 1.0 ft on level ground where there is no potential for erosion or future excavation of the soil in front of the wall toe.

For walls constructed along rivers and streams, embedment depths shall be established at a minimum of 2.0 ft below potential scour depth as determined in accordance with Article 11.6.3.5.

As an alternative to locating the wall base below the depth of frost penetration where frost susceptible soils are present, the soil within the depth and lateral extent of frost penetration below the wall can be removed and replaced with nonfrost susceptible clean granular soil.

A minimum horizontal bench width of 4.0 ft shall be provided in front of walls founded on slopes. The bench may be formed or the slope continued above that level as shown in Figure 11.10.2-1.

The lowest backfill reinforcement layer shall not be located above the long-term ground surface in front of the wall.

11.10.2.3—Facing

Facing elements shall be designed to resist the horizontal force in the soil reinforcements at the reinforcement to facing connection, as specified in Articles 11.10.6.2.2 and 11.10.7.3.

In addition to these horizontal forces, the facing elements shall also be designed to resist potential compaction stresses occurring near the wall face during erection of the wall.

The tension in the reinforcement may be assumed to be resisted by a uniformly distributed earth pressure on the back of the facing.

The facing shall be stabilized such that it does not deflect laterally or bulge beyond the established tolerances.

C11.10.2.2

The minimum embedment guidelines provided in Table C11.10.2.2-1 may be used to preclude local bearing resistance failure under the leveling pad or footing due to higher vertical stresses transmitted by the facing.

Table C11.10.2.2-1—Guide for Minimum Front Face Embedment Depth

Slope in Front of Structures		Minimum Embedment Depth
	for walls	$H/20.0$
Horizontal	for abutments	$H/10.0$
$3.0H:1.0V$	walls	$H/10.0$
$2.0H:1.0V$	walls	$H/7.0$
$1.5H:1.0V$	walls	$H/5.0$

For structures constructed on slopes, minimum horizontal benches are intended to provide resistance to local bearing resistance failure consistent with resistance to general bearing resistance failure and to provide access for maintenance inspections.

C11.10.2.3

See Article C3.11.2 for guidance. Additional information on compaction stresses can be found in Duncan and Seed (1986) and Duncan et al. (1991). Alternatively, compaction stresses can be addressed through the use of facing systems which have a proven history of being able to resist the compaction activities anticipated behind the wall and which have performed well in the long-term.

11.10.2.3.1—Stiff or Rigid Concrete, Steel, and Timber Facings

Facing elements shall be structurally designed in accordance with Sections 5, 6, and 8 for concrete, steel, and timber facings, respectively.

The minimum thickness for concrete panels at, and in the zone of stress influence of, embedded connections shall be 5.5 in. and 3.5 in. elsewhere. The minimum concrete cover shall be 1.5 in. Reinforcement shall be provided to resist the average loading conditions for each panel. Temperature and shrinkage steel shall be provided as specified in Article 5.10.8.

The structural integrity of concrete face panels shall be evaluated with respect to the shear and bending moment between reinforcements attached to the facing panel in accordance with Section 5.

For segmental concrete facing blocks, facing stability calculations shall include an evaluation of the maximum vertical spacing between reinforcement layers, the maximum allowable facing height above the uppermost reinforcement layer, inter-unit shear capacity, and resistance of the facing to bulging. The maximum spacing between reinforcement layers shall be limited to twice the width, W_u illustrated in Figure 11.10.6.4.4b-1, of the segmental concrete facing block unit or 2.7 ft, whichever is less. The maximum facing height up to the wall surface grade above the uppermost reinforcement layer shall be limited to $1.5W_u$ illustrated in Figure 11.10.6.4.4b-1 or 24.0 in., whichever is less, provided that the facing above the uppermost reinforcement layer is demonstrated to be stable against a toppling failure through detailed calculations. The maximum depth of facing below the lowest reinforcement layer shall be limited to the width, W_u , of the proposed segmental concrete facing block unit.

11.10.2.3.2—Flexible Wall Facings

If welded wire, expanded metal, or similar facing is used, they shall be designed in a manner which prevents the occurrence of excessive bulging as backfill behind the facing compresses due to compaction stresses or self weight of the backfill. This may be accomplished by limiting the size of individual facing elements vertically and the vertical and horizontal spacing of the soil reinforcement layers, and by requiring the facing to have an adequate amount of vertical slip and overlap between adjacent elements.

The top of the flexible facing at the top of the wall shall be attached to a soil reinforcement layer to provide stability to the top facing.

C11.10.2.3.1

The specified minimum panel thicknesses and concrete cover recognize that MSE walls are often employed where panels may be exposed to salt spray and/or other corrosive environments. The minimum thicknesses also reflect the tolerances on panel thickness, and placement of reinforcement and connectors that can reasonably be conformed to in precast construction.

Based on research by Allen and Bathurst (2001), facings consisting of segmental concrete facing blocks behave as a very stiff facing, due to the ability of the facing blocks to transmit moment in a vertical direction throughout the facing column, and appear to have even greater stiffness than incremental precast concrete panels.

Experience has shown that for walls with segmental concrete block facings, the gap between soil reinforcement sections or strips at a horizontal level should be limited to a maximum of one block width to limit bulging of the facing between reinforcement levels or build up of unacceptable stresses that could result in performance problems. The ability of the facing to carry moment horizontally to bridge across the gaps in the reinforcement horizontally should be evaluated if horizontally discontinuous reinforcement is used, i.e., a reinforcement coverage ratio $R_c < 1$.

C11.10.2.3.2

Experience has shown that for welded wire, expanded metal, or similar facings, vertical reinforcement spacing should be limited to a maximum of 2.0 ft and the gap between soil reinforcement at a horizontal level limited to a maximum of 3.0 ft to limit bulging of the panels between reinforcement levels. The section modulus of the facing material should be evaluated and calculations provided to support reinforcement spacings, which will meet the bulging requirements stated in Article C11.10.4.2.

Geosynthetic facing elements shall not, in general, be left exposed to sunlight (specifically ultraviolet radiation) for permanent walls. If geosynthetic facing elements must be left exposed permanently to sunlight, the geosynthetic shall be stabilized to be resistant to ultraviolet radiation. Product specific test data shall be provided which can be extrapolated to the intended design life and which proves that the product will be capable of performing as intended in an exposed environment.

11.10.2.3.3—Corrosion Issues for MSE Facing

Steel-to-steel contact between the soil reinforcement connections and the concrete facing steel reinforcement shall be prevented so that contact between dissimilar metals, e.g., bare facing reinforcement steel and galvanized soil reinforcement steel, does not occur.

A corrosion protection system shall be provided where salt spray is anticipated.

11.10.3—Loading

The provisions of Article 11.6.1.2 shall apply, except that shrinkage and temperature effects need not be considered to come in contact with steel wall elements.

11.10.4—Movement and Stability at the Service Limit State

11.10.4.1—Settlement

The provisions of Article 11.6.2 shall apply as applicable.

The allowable settlement of MSE walls shall be established based on the longitudinal deformability of the facing and the ultimate purpose of the structure.

Where foundation conditions indicate large differential settlements over short horizontal distances, vertical full-height slip joints shall be provided.

Differential settlement from the front to the back of the wall shall also be evaluated, especially regarding the effect on facing deformation, alignment, and connection stresses.

C11.10.2.3.3

Steel-to-steel contact in this case can be prevented through the placement of a nonconductive material between the soil reinforcement face connection and the facing concrete reinforcing steel. Examples of measures which can be used to mitigate corrosion include, but are not limited to, coatings, sealants, or increased panel thickness.

C11.10.4.1

For systems with rigid concrete facing panels and with a maximum joint width of 0.75 in., the maximum tolerable slope resulting from calculated differential settlement may be taken as given in Table C11.10.4.1-1.

Table C11.10.4.1-1—Guide for Limiting Distortion for Precast Concrete Facings of MSE Walls

Joint Width (in.)	Limiting Differential Settlement	
	Area ≤ 30 ft ²	30 ft ² ≤ Area ≤ 75 ft ²
0.75	1/100	1/200
0.50	1/200	1/300
0.25	1/300	1/600

For MSE walls with full height precast concrete facing panels, total settlement should be limited to 2.0 in., and the limiting differential settlement should be 1/500. For walls with segmental concrete block facings, the limiting differential settlement should be 1/200. For walls with welded wire facings or walls in which cast-in-place concrete or shotcrete facing is placed after wall settlement is essentially complete, the limiting

differential settlement should be 1/50. These limiting differential settlement criteria consider only structural needs of the facing. More stringent differential settlement criteria may be needed to meet aesthetic requirements.

11.10.4.2—Lateral Displacement

Lateral wall displacements shall be estimated as a function of overall structure stiffness, compaction intensity, soil type, reinforcement length, slack in reinforcement-to-facing connections, and deformability of the facing system or based on monitored wall performance.

C11.10.4.2

A first order estimate of lateral wall displacements occurring during wall construction for simple MSE walls on firm foundations can be obtained from Figure C11.10.4.2-1. If significant vertical settlement is anticipated or heavy surcharges are present, lateral displacements could be considerably greater. Figure C11.10.4.2-1 is appropriate as a guide to establish an appropriate wall face batter to obtain a near vertical wall or to determine minimum clearances between the wall face and adjacent objects or structures.

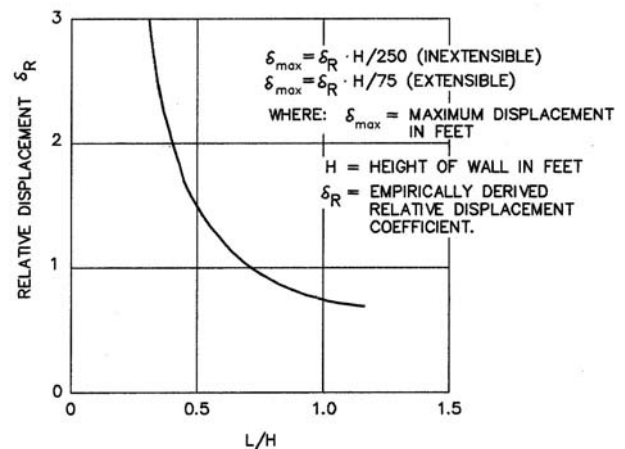

Based on 20 ft. high walls, relative displacement increases approximately 25% for every 400 psf of surcharge. Experience indicates that for higher walls, the surcharge effect may be greater.

Note: This figure is only a guide. Actual displacement will depend, in addition to the parameters addressed in the figure, on soil characteristics, compaction effort, and contractor workmanship.

Figure C11.10.4.2-1—Empirical Curve for Estimating Anticipated Lateral Displacement during Construction for MSE Walls

For additional explanation on how to use this figure, see Berg et al. (2009).

For welded wire or similarly faced walls such as gabion faced walls, the maximum tolerable facing bulge between connections, both horizontally and vertically, with soil reinforcement is approximately 2.0 in. For geosynthetic facings, the maximum facing bulge between reinforcement layers should be approximately 2.75 in. for 1.0 ft vertical reinforcement spacing to 5.0 in. for 2.0 ft vertical reinforcement spacing.

11.10.4.3—Overall Stability

The provisions of Article 11.6.2.3 shall apply. Additionally for MSE walls with complex geometrics,

compound failure surfaces which pass through a portion of the reinforced soil mass as illustrated in Figure 11.10.4.3-1 shall be investigated, especially where the wall is located on sloping or soft ground where overall stability may be inadequate. The long-term strength of each backfill reinforcement layer intersected by the failure surface should be considered as restoring forces in the limit equilibrium slope stability analysis.

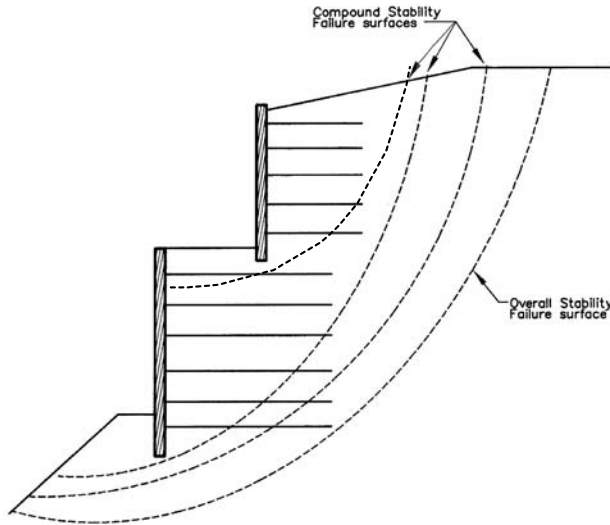

Figure 11.10.4.3-1—Overall and Compound Stability of Complex MSE Wall Systems

11.10.5—Safety against Soil Failure (External Stability)

11.10.5.1—General

MSE structures shall be proportioned to satisfy eccentricity and sliding criteria normally associated with gravity structures.

Safety against soil failure shall be evaluated by assuming the reinforced soil mass to be a rigid body. The coefficient of active earth pressure, k_a , used to compute the earth pressure of the retained soil behind the reinforced soil mass shall be determined using the friction angle of the retained soil. In the absence of specific data, a maximum friction angle of 30 degrees may be used for granular soils. Tests should be performed to determine the friction angle of cohesive soils considering both drained and undrained conditions.

C11.10.5.1

Eccentricity requirements seldom govern design. Sliding and overall stability usually govern design of structures greater than 30.0 ft in height, structures constructed on weak foundation soils, or structures loaded with sloping surcharges.

11.10.5.2—Loading

Lateral earth pressure distributions for design of MSE walls shall be taken as specified in Article 3.11.5.8. Application of loads for external and internal stability shall be taken as specified in Articles 11.10.5 and 11.10.6, respectively. Application of surcharge loads shall be taken as specified in Article 11.10.11. Application of load factors for these loads shall be taken as specified in Article 11.5.5.

For external stability calculations only, the active earth pressure coefficients for retained backfill, i.e., fill behind the reinforced soil mass, shall be taken as specified in Article 3.11.5.3 with $\delta = \beta$.

Dead load surcharges, if present, shall be taken into account in accordance with Article 11.10.10.

For investigation of sliding stability and eccentricity, the continuous traffic surcharge loads shall be considered to act beyond the end of the reinforced zone as shown in Figure 11.10.5.2-1. Application of load factors for these loads shall be taken as specified in Article 11.5.5.

C11.10.5.2

Figures 3.11.5.8.1-1, 3.11.5.8.1-2, and 3.11.5.8.1-3 illustrate lateral earth pressure distributions for external stability of MSE walls with horizontal backslope, inclined backslope, and broken backslope, respectively.

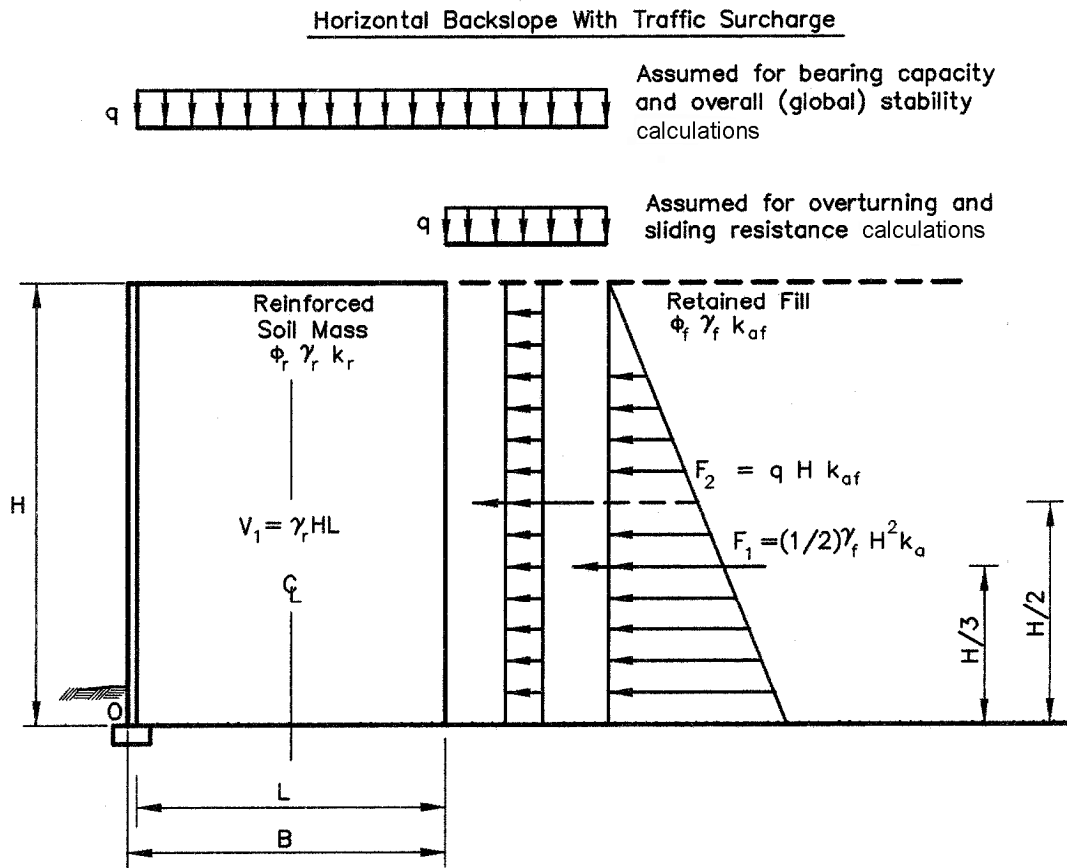

Figure 11.10.5.2-1—External Stability for Wall with Horizontal Backslope and Traffic Surcharge

11.10.5.3—Sliding

The provisions of Article 10.6.3.4 shall apply.

The coefficient of sliding friction at the base of the reinforced soil mass shall be determined using the friction angle of the foundation soil. For discontinuous reinforcements, e.g., strips, the angle of sliding friction shall be taken as the lesser of ϕ_r of the reinforced fill and ϕ_f of the foundation soil. For continuous reinforcements, e.g., grids and sheets, the angle of sliding friction shall be taken as the lesser of ϕ_r , ϕ_f and ρ , where ρ is the soil-reinforcement interface friction angle. In the absence of specific data, a maximum friction angle, ϕ_f , of 30 degrees and a maximum soil-reinforcement interface angle, ρ , of $2/3 \phi_f$ may be used.

11.10.5.4—Bearing Resistance

For the purpose of computing bearing resistance, an equivalent footing shall be assumed whose length is the length of the wall, and whose width is the length of the reinforcement strip at the foundation level. Bearing pressures shall be computed using a uniform base pressure distribution over an effective width of footing determined in accordance with the provisions of Articles 10.6.3.1 and 10.6.3.2.

Where soft soils or sloping ground in front of the wall are present, the difference in bearing stress calculated for the wall reinforced soil zone relative to the local bearing stress beneath the facing elements shall be considered when evaluating bearing capacity. In both cases, the leveling pad shall be embedded adequately to meet bearing capacity requirements.

11.10.5.5—Overturning

The provisions of Article 11.6.3.3 shall apply.

C11.10.5.3

For relatively thick facing elements, it may be desirable to include the facing dimensions and weight in sliding and overturning calculations, i.e., use B in lieu of L as shown in Figure 11.10.5.2-1.

C11.10.5.4

The effect of eccentricity and load inclination is accommodated by the introduction of an effective width, $B' = L - 2e$, instead of the actual width.

For relatively thick facing elements, it may be reasonable to include the facing dimensions and weight in bearing calculations, i.e., use B in lieu of L as shown in Figure 11.10.2-1.

Note, when the value of eccentricity e is negative: $B' = L$.

Due to the flexibility of MSE walls, a triangular pressure distribution at the wall base cannot develop, even if the wall base is founded on rock, as the reinforced soil mass has limited ability to transmit moment. Therefore, an equivalent uniform base pressure distribution is appropriate for MSE walls founded on either soil or rock.

Concentrated bearing stresses from the facing weight on soft soil could create concentrated stresses at the connection between the facing elements and the wall backfill reinforcement.

11.10.6—Safety against Structural Failure (Internal Stability)

11.10.6.1—General

Safety against structural failure shall be evaluated with respect to pullout and rupture of reinforcement.

A preliminary estimate of the structural size of the stabilized soil mass may be determined on the basis of reinforcement pullout beyond the failure zone, for which resistance is specified in Article 11.10.6.3.

11.10.6.2—Loading

The load in the reinforcement shall be determined at two critical locations: the zone of maximum stress and the connection with the wall face. Potential for reinforcement rupture and pullout are evaluated at the zone of maximum stress, which is assumed to be located at the boundary between the active zone and the resistant zone in Figure 11.10.2-1. Potential for reinforcement rupture and pullout are also evaluated at the connection of the reinforcement to the wall facing.

The maximum friction angle used for the computation of horizontal force within the reinforced soil mass shall be assumed to be 34 degrees, unless the specific project select backfill is tested for frictional strength by triaxial or direct shear testing methods, AASHTO T 296 and T 297 or T 236, respectively. A design friction angle of greater than 40 degrees shall not be used with the Simplified Method even if the measured friction angle is greater than 40 degrees.

C11.10.6.1

The resistance factors, specified in Article 11.5.6, are consistent with the use of select backfill in the reinforced zone, homogeneously placed and carefully controlled in the field for conformance with Section 7 of *AASHTO LRFD Bridge Construction Specifications*. The basis for the factors is the successful construction of thousands of structures in accordance with these criteria, and the use of conservative pullout resistance factors representing high confidence limits.

C11.10.6.2

Loads carried by the soil reinforcement in mechanically stabilized earth walls are the result of vertical and lateral earth pressures, which exist within the reinforced soil mass, reinforcement extensibility, facing stiffness, wall toe restraint, and the stiffness and strength of the soil backfill within the reinforced soil mass. The soil reinforcement extensibility and material type are major factors in determining reinforcement load. In general, inextensible reinforcements consist of metallic strips, bar mats, or welded wire mats, whereas extensible reinforcements consist of geotextiles or geogrids. Inextensible reinforcements reach their peak strength at strains lower than the strain required for the soil to reach its peak strength. Extensible reinforcements reach their peak strength at strains greater than the strain required for soil to reach its peak strength. Internal stability failure modes include soil reinforcement rupture (strength limit state), and excessive reinforcement elongation under the design load (service limit state). The service limit state is not evaluated in current practice for internal stability design. Internal stability is determined by equating the factored tensile load applied to the reinforcement to the factored tensile resistance of the reinforcement, the tensile resistance being governed by reinforcement rupture and pullout.

Analysis of full scale wall data in comparison to the Simplified Method or other widely accepted design methods (see Article 11.10.6.2.1) indicates that these methods will significantly underestimate reinforcement loads if design soil friction angles greater than 40 degrees are used. This recommendation applies to soil friction angles as determined using triaxial or direct shear tests, as the Simplified Method was calibrated using triaxial or direct shear soil strengths (see Allen et al., 2001).

11.10.6.2.1—Maximum Reinforcement Loads

Maximum reinforcement loads shall be calculated using the Simplified Method or the Coherent Gravity Method. The Simplified Method shall be considered to apply to both steel and geosynthetic reinforced wall systems. The Coherent Gravity Method shall be applied primarily to steel soil reinforcement systems. For the Simplified Method, the load in the reinforcements shall be obtained by multiplying the vertical earth pressure at the reinforcement by a lateral earth pressure coefficient, and applying the resulting lateral pressure to the tributary area for the reinforcement. For the Coherent Gravity Method, the load in the reinforcements shall be obtained in the same way as the Simplified Method, except as follows:

- The vertical earth pressure at each reinforcement level shall be computed using an equivalent uniform base pressure distribution over an effective width of reinforced wall mass determined in accordance with the provisions of Articles 11.6.3.1 and 11.6.3.2, and
- For steel reinforced wall systems, the lateral earth pressure coefficient used shall be equal to k_0 at the point of intersection of the theoretical failure surface with the ground surface at or above the wall top, transitioning to k_a at a depth of 20.0 ft below that intersection point, and constant at k_a at depths greater than 20.0 ft. If used for geosynthetic reinforced systems, k_a shall be used throughout the wall height.

All other provisions in this article are applicable to both methods.

Other widely accepted and published design methods for calculation of reinforcement loads may be used at the discretion of the wall owner or approving agency, provided the designer develops method-specific resistance factors for the method employed.

For the Simplified Method, factored horizontal stress, σ_H , at each reinforcement level shall be determined as:

$$\sigma_H = \gamma_P (\sigma_v k_r + \Delta\sigma_H) \quad (11.10.6.2.1-1)$$

where:

- γ_P = the load factor for vertical earth pressure EV from Table 3.4.1-2
- k_r = horizontal pressure coefficient (dim.)
- σ_v = pressure due to resultant of gravity forces from soil self weight within and immediately above the reinforced wall backfill, and any surcharge loads present (ksf)

C11.10.6.2.1

The development of the Simplified Method for estimating reinforcement loads is provided in Allen, et al. (2001). The Coherent Gravity Method has been used in MSE wall design practice for many years for steel reinforced wall systems. Detailed procedures for the Coherent Gravity Method are provided in Allen, et al. (2001) and in Mitchell and Villet (1987). Its application to geosynthetic soil reinforcement systems results in conservative designs.

The design specifications provided herein assume that the wall facing combined with the reinforced backfill acts as a coherent unit to form a gravity retaining structure. Research by Allen and Bathurst (2003) and Allen et al. (2003) indicates that reinforcement load is linear with reinforcement spacing to a reinforcement vertical spacing of 2.7 ft or more, though a vertical spacing of this magnitude should not be attempted unless the facing is considered to be adequately stiff to prevent excessive bulging between layers (see Article C11.10.2.3.2).

These MSE wall specifications also assume that inextensible reinforcements are not mixed with extensible reinforcements within the same wall. MSE walls which contain a mixture of inextensible and extensible reinforcements are not recommended.

The calculation method for T_{max} is empirically derived, based on reinforcement strain measurements, converted to load based on the reinforcement modulus, from full scale walls at working stress conditions. The load factor EV , on the other hand, was determined in consideration of vertical earth pressure exerted by a soil mass without inclusions, and was calibrated to address uncertainties implied by allowable stress design for external stability for walls. EV is not directly applicable to internal reinforcement loads in MSE walls, since the calibration of EV was not performed with internal stability of a reinforced system in mind.

The use of EV for the load factor in this case for both methods (i.e., the Simplified and Coherent Gravity Methods) should be considered an interim measure until research is completed to quantify load prediction bias and uncertainty.

$\Delta\sigma_H$ = horizontal stress at reinforcement level resulting from any applicable concentrated horizontal surcharge load as specified in Article 11.10.10.1 (ksf)

For the Simplified Method, vertical stress for maximum reinforcement load calculations shall be determined as shown in Figures 11.10.6.2.1-1 and 11.10.6.2.1-2. For the Coherent Gravity Method, vertical stress shall be calculated at each reinforcement level using an equivalent uniform base pressure that accounts for load eccentricity caused by the lateral earth pressure acting at the back of the reinforced soil mass above the reinforcement level being considered. This base pressure shall be applied over an effective width of reinforced wall mass determined in accordance with the provisions of Articles 11.6.3.1 and 11.6.3.2. As is true for the Simplified Method, live load is not included in the vertical stress calculation to determine T_{max} for assessing pullout loads when using the Coherent Gravity Method.

Sloping soil surcharges are taken into account through an equivalent uniform surcharge and assuming a level backslope condition. For these calculations, the depth Z is referenced from the top of the wall at the wall face, excluding any copings and appurtenances.

Note that T_{max} , the factored tensile load in the soil reinforcement, must be calculated twice for internal stability design as follows: (1) for checking reinforcement and connection rupture, determine T_{max} with live load surcharge included in the calculation of σ_v ; (2) for checking pullout, determine T_{max} with live load surcharge excluded from the calculation of σ_v .

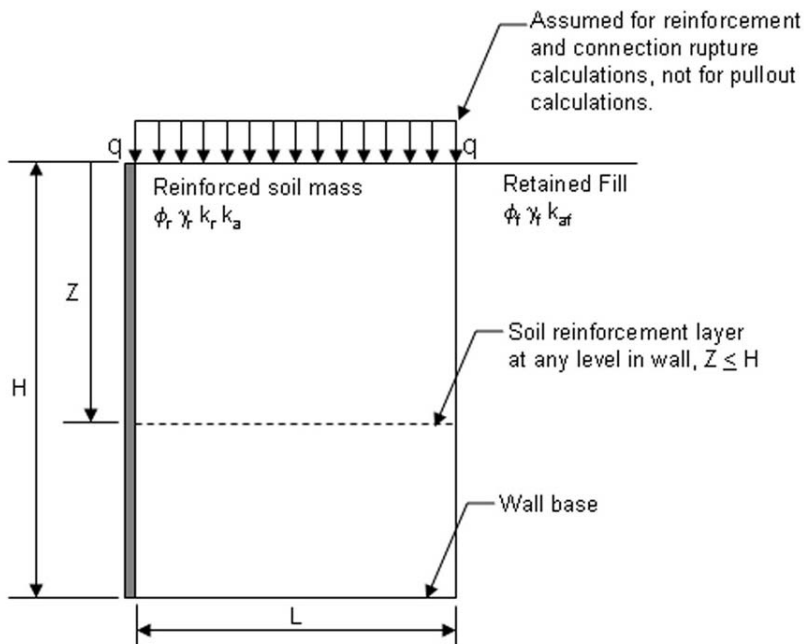

$$\text{Max Stress: } \sigma_v = \gamma_r Z + q + \Delta\sigma_v$$

$$\text{Pullout: } \sigma_v = \gamma_r Z + \Delta\sigma_v$$

Note: $\Delta\sigma_v$ is determined from Figure 11.10.10.1-1.

H is the total wall height at the face.

Figure 11.10.6.2.1-1—Calculation of Vertical Stress for Horizontal Backslope Condition, Including Live Load and Dead Load Surcharges for Internal Stability Analysis

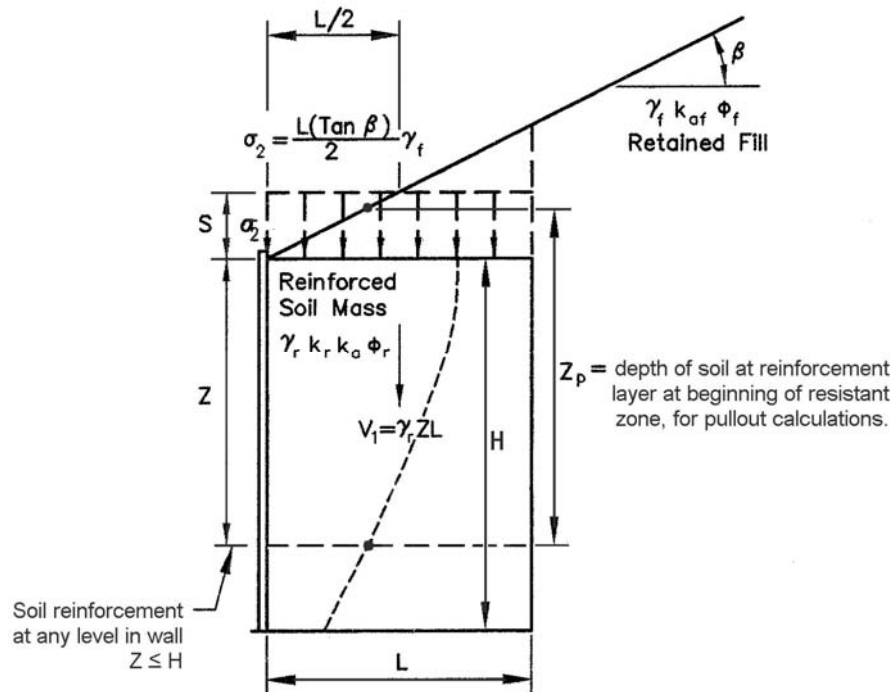

Max Stress: $S = (1/2)L \tan \beta$

$\sigma_v = \gamma_r Z + (1/2)L(\tan \beta) \gamma_f$

Determine k_{af} using a slope angle of β

Determine k_r from Figure 11.10.6.2.1-3

Pullout: $\sigma_v = \gamma_r Z_p$ and $Z_p \geq Z + S$

Note: H is the total height of the wall at the face.

Figure 11.10.6.2.1-2—Calculation of Vertical Stress for Sloping Backslope Condition for Internal Stability Analysis

For the Simplified Method, the lateral earth pressure coefficient k_r is determined by applying a multiplier to the active earth pressure coefficient, k_a . The k_a multiplier for the Simplified Method shall be determined as shown in Figure 11.10.6.2.1-3. For assessment of reinforcement pullout, the Simplified Method multiplier for steel strip walls shall be used for all steel reinforced walls. For reinforcement rupture, the multiplier applicable to the specific type of steel reinforcement shall be used. For the Coherent Gravity Method, the lateral earth pressure coefficient used for internal stability design of steel reinforced MSE wall systems shall be determined as shown in Figure 11.10.6.2.1-4. For geosynthetic reinforced wall systems, k_a is used throughout the wall height. For both methods, k_a shall be determined using Eq. 3.11.5.3-1, assuming no wall friction, i.e., $\delta = \beta$. For the Coherent Gravity Method, k_0 shall be determined using Eq. 3.11.5.2-1.

Since it is assumed that $\delta = \beta$, and β is assumed to always be zero for internal stability, for a vertical wall, the Coulomb equation simplifies mathematically to the simplest form of the Rankine equation.

The applied factored load to the reinforcements, T_{max} , shall be determined using a load per unit of wall width basis as follows:

$$T_{max} = \sigma_H S_v \quad (11.10.6.2.1-2)$$

where:

σ_H = factored horizontal soil stress at the reinforcement (ksf)
 S_v = vertical spacing of the reinforcement (ft)

A vertical spacing, S_v , greater than 2.7 ft should not be used without full scale wall data (e.g., reinforcement loads and strains, and overall deflections) that support the acceptability of larger vertical spacing.

Live loads shall be positioned for extreme force effect. The provisions of Article 3.11.6 shall apply.

$$k_a = \tan^2 \left(45 - \frac{\phi'_f}{2} \right) \quad (C11.10.6.2.1-1)$$

If the wall face is battered, the following simplified form of the Coulomb equation can be used:

$$k_a = \frac{\sin^2(\theta + \phi'_f)}{\sin^3 \theta \left(1 + \frac{\sin \phi'_f}{\sin \theta} \right)^2} \quad (C11.10.6.2.1-2)$$

with variables as defined in Figure 3.11.5.3-1.

Based on Figure 11.10.6.2.1-3, the k_a multiplier is a function of the reinforcement type and the depth of the reinforcement below the wall top. Multipliers for other reinforcement types can be developed as needed through analysis of measurements of reinforcement load and strain in full scale structures.

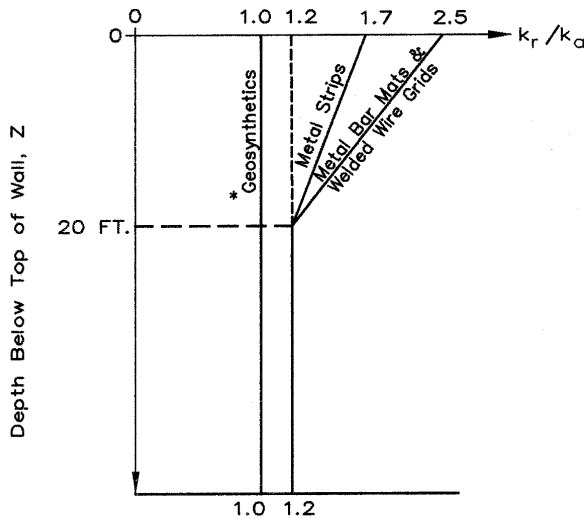

* Does not apply to polymer strip reinforcement

Figure 11.10.6.2.1-3—Variation of the Coefficient of Lateral Stress Ratio k_r/k_a with Depth in a Mechanically Stabilized Earth Wall

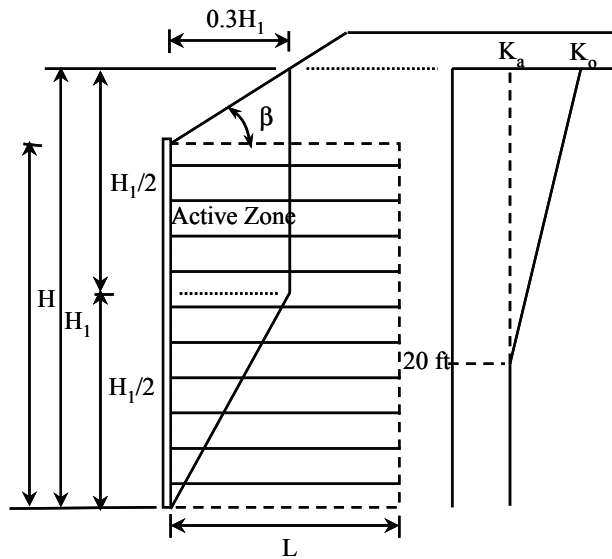

Figure 11.10.6.2.1-4—Determination of Lateral Earth Pressure Coefficients for Internal Stability Design of Steel Reinforced MSE Walls Using the Coherent Gravity Method

11.10.6.2.2—Reinforcement Loads at Connection to Wall Face

The factored tensile load applied to the soil reinforcement connection at the wall face, T_o , shall be equal to the maximum factored reinforcement tension, T_{max} , for all wall systems regardless of facing and reinforcement type.

11.10.6.3—Reinforcement Pullout

11.10.6.3.1—Boundary between Active and Resistant Zones

The location of the zone of maximum stress for inextensible and extensible wall systems, i.e., the boundary between the active and resistant zones, is determined as shown in Figure 11.10.6.3.1-1. For all wall systems, the zone of maximum stress shall be assumed to begin at the back of the facing elements at the toe of the wall.

For extensible wall systems with a face batter of less than ten degrees from the vertical, the zone of maximum stress should be determined using the Rankine method. Since the Rankine method cannot account for wall face batter or the effect of concentrated surcharge loads above the reinforced backfill zone, the Coulomb method shall be used for walls with extensible reinforcement in cases of significant batter, defined as ten degrees from vertical or more, and concentrated surcharge loads to determine the location of the zone of maximum stress.

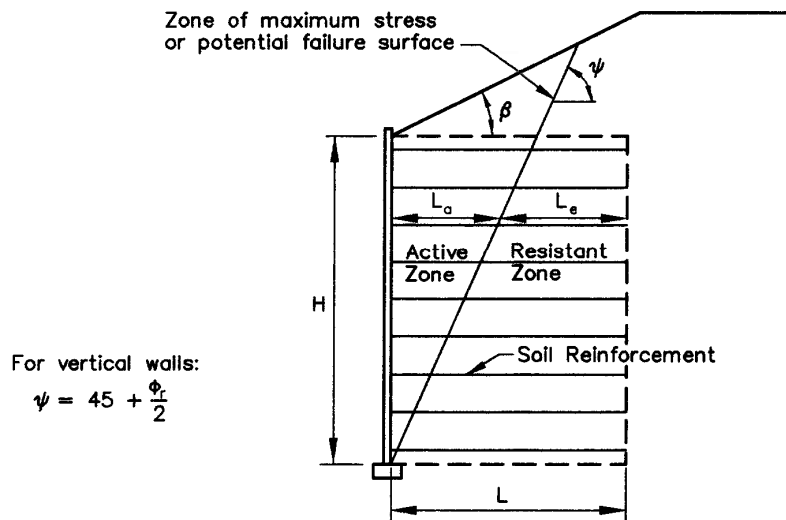
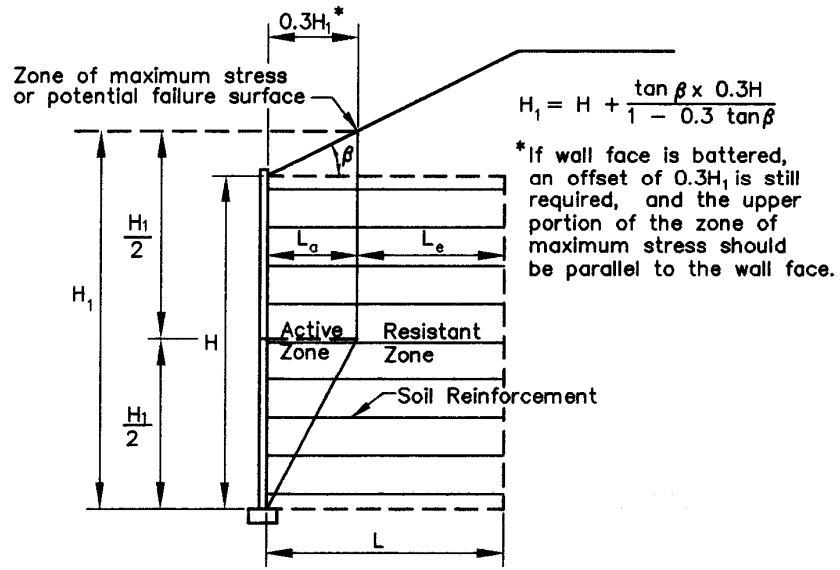

For walls with a face batter 10 degrees or more from the vertical,

$$\tan(\Psi - \phi_r) = \frac{-\tan(\phi_r - \beta) + \sqrt{\tan(\phi_r - \beta) [\tan(\phi_r - \beta) + \cot(\phi_r + \theta - 90)] [1 + \tan(\delta + 90 - \theta) \cot(\phi_r + \theta - 90)]}}{1 + \tan(\delta + 90 - \theta) [\tan(\phi_r - \beta) + \cot(\phi_r + \theta - 90)]}$$

with $\delta = \beta$ and all other variables defined in Figure 3.11.5.3-1.

Figure 11.10.6.3.1-1—Location of Potential Failure Surface for Internal Stability Design of MSE Walls

11.10.6.3.2—Reinforcement Pullout Design

C11.10.6.3.2

The reinforcement pullout resistance shall be checked at each level against pullout failure. Only the effective pullout length which extends beyond the theoretical failure surfaces in Figure 11.10.6.3.1-1 shall be used in this calculation. A minimum length, L_e , in the resistant zone of 3.0 ft shall be used. The total length of reinforcement required for pullout is equal to $L_a + L_e$ as shown in Figure 11.10.6.3.1-1.

Note that traffic loads are neglected in pullout calculations (see Figure 11.10.6.2.1-1).

The effective pullout length shall be determined using the following equation:

$$L_e \geq \frac{T_{max}}{\phi F^* \alpha \sigma_v C R_c} \quad (11.10.6.3.2-1)$$

$F^* \alpha \sigma_v C L_e$ is the ultimate pullout resistance P_r per unit of reinforcement width.

where:

- L_e = length of reinforcement in resisting zone (ft)
- T_{max} = applied factored load in the reinforcement from Eq. 11.10.6.2.1-2 (kips/ft)
- ϕ = resistance factor for reinforcement pullout from Table 11.5.7-1 (dim.)
- F^* = pullout friction factor (dim.)
- α = scale effect correction factor (dim.)
- σ_v = unfactored vertical stress at the reinforcement level in the resistant zone (ksf)
- C = overall reinforcement surface area geometry factor based on the gross perimeter of the reinforcement and is equal to 2 for strip, grid and sheet-type reinforcements, i.e., two sides (dim.)
- R_c = reinforcement coverage ratio from Article 11.10.6.4.1 (dim.)

F^* and α shall be determined from product-specific pullout tests in the project backfill material or equivalent soil, or they can be estimated empirically/theoretically.

For standard backfill materials (see *AASHTO LRFD Bridge Construction Specifications*, Article 7.3.6.3), with the exception of uniform sands, i.e., coefficient of uniformity $C_u = D_{60}/D_{10} < 4$, in the absence of test data it is acceptable to use conservative default values for F^* and α as shown in Figure 11.10.6.3.2-1 and Table 11.10.6.3.2-1. For ribbed steel strips, if the specific C_u for the wall backfill is unknown at the time of design, a C_u of 4.0 should be assumed for design to determine F^* .

Pullout testing and interpretation procedures (and direct shear testing for some parameters), as well as typical empirical data, are provided in Appendix A of FHWA-NHI-10-025 (Berg et al., 2009).

Recent experience with pullout test results on new geogrids coming into the market has indicated that some materials have pullout values that are lower than the previous F^* default value of $0.8 \tan \phi$. Data obtained by D’Appolonia (1999) also indicates that $0.8 \tan \phi$ is closer to a mean value rather than a default lower bound value for geogrids. The default values for other reinforcement types shown in Figure 11.10.6.3.2-1 are more representative of lower bound values. The F^* default value has thus been lowered to a more conservative value of $0.67 \tan \phi$ in consideration of these results.

Table 11.10.6.3.2-1—Default Values for the Scale Effect Correction Factor, α

Reinforcement Type	Default Value for α
All Steel Reinforcements	1.0
Geogrids	0.8
Geotextiles	0.6

For grids, the spacing between transverse grid elements, S_t , shall be uniform throughout the length of the reinforcement rather than having transverse grid members concentrated only in the resistant zone.

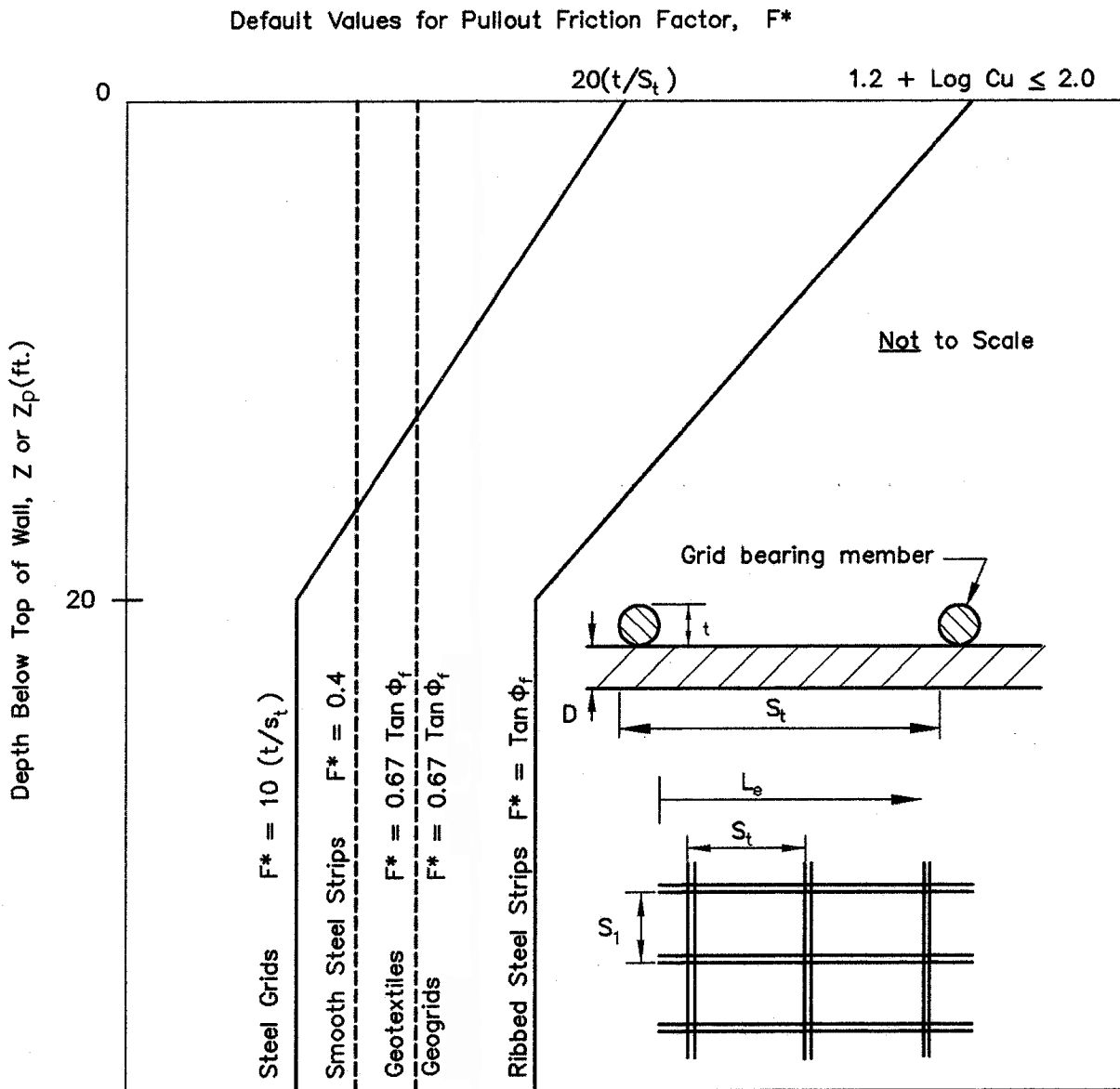

Figure 11.10.6.3.2-1—Default Values for the Pullout Friction Factor, F^*

These pullout calculations assume that the factored long-term strength of the reinforcement (see Article 11.10.6.4.1) in the resistant zone is greater than T_{max} .

11.10.6.4—Reinforcement Strength

11.10.6.4.1—General

The reinforcement strength shall be checked at every level within the wall, both at the boundary between the active and resistant zones (i.e., zone of maximum stress), and at the connection of the reinforcement to the wall face, for applicable strength limit states as follows:

At the zone of maximum stress:

$$T_{\max} \leq \phi T_{al} R_c \quad (11.10.6.4.1-1)$$

where:

- T_{\max} = applied factored load to the reinforcement determined from Eq. 11.10.6.2.1-2 (kips/ft)
- ϕ = resistance factor for reinforcement tension, specified in Table 11.5.7-1 (dim.)
- T_{al} = nominal long-term reinforcement design strength (kips/ft)
- R_c = reinforcement coverage ratio specified in Article 11.10.6.4.1 (dim.)

T_{al} shall be determined as specified in Article 11.10.6.4.3a for steel reinforcement and Article 11.10.6.4.3b for geosynthetic reinforcement.

At the connection with the wall face:

$$T_o \leq \phi T_{ac} R_c \quad (11.10.6.4.1-2)$$

where:

- T_o = applied factored load at reinforcement/facing connection specified in Article 11.10.6.2.2 (kips/ft)
- ϕ = resistance factor for reinforcement tension in connectors specified in Table 11.5.7-1 (dim.)
- T_{ac} = nominal long-term reinforcement/facing connection design strength (kips/ft)
- R_c = reinforcement coverage ratio specified in Article 11.10.6.4.1 (dim.)

T_{ac} shall be determined at the wall face connection as specified in Article 11.10.6.4.4a for steel reinforcement and Article 11.10.6.4.4b for geosynthetic reinforcement. The difference in the environment occurring immediately behind the wall face relative to the environment within the reinforcement backfill zone and its effect on the long-term durability of the reinforcement/connection shall be considered when determining T_{ac} .

C11.10.6.4.1

The serviceability limit state is not specifically evaluated in current practice to design backfill reinforcement for internal stability. A first order estimate of lateral deformation of the entire wall structure, however, can be obtained as shown in Article 11.10.4.2.

T_{at} shall be determined on a long-term strength per unit of reinforcement width basis and multiplied by the reinforcement coverage ratio R_c so that it can be directly compared to T_{max} which is determined on a load per unit of wall width basis (this also applies to T_{ac} and T_o). For discrete, i.e., not continuous, reinforcements, such as steel strips or bar mats, the strength of the reinforcement is converted to a strength per unit of wall width basis as shown in Figures 11.10.6.4.1-1 and 11.10.6.4.1-2. For continuous reinforcement layers, $b = 1$ and $R_c = 1$.

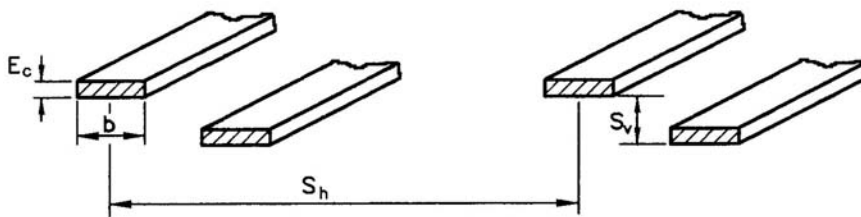

$$A_c = bE_c$$

E_c = strip thickness corrected for corrosion loss.

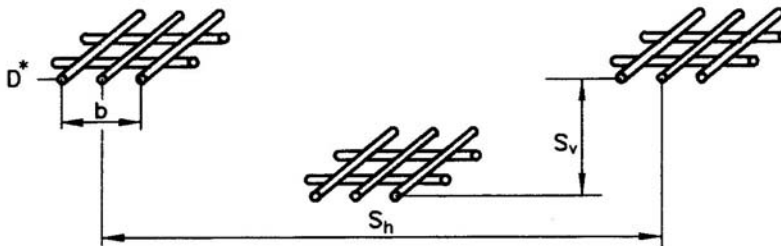

$$A_c = (\text{No. of longitudinal bars}) \left(\pi \frac{D^{*2}}{4} \right)$$

D^* = diameter of bar or wire corrected for corrosion loss.

b = unit width of reinforcement (if reinforcement is continuous count number of bars for reinforcement width of 1 unit).

$$R_c = \text{reinforcement coverage ratio} = \frac{b}{S_h}$$

Use $R_c = 1$ for continuous reinforcement (i.e., $S_h = b = 1$ unit width).

Figure 11.10.6.4.1-1—Reinforcement Coverage Ratio for Metal Reinforcement

Discontinuous Geosynthetic Sheets:

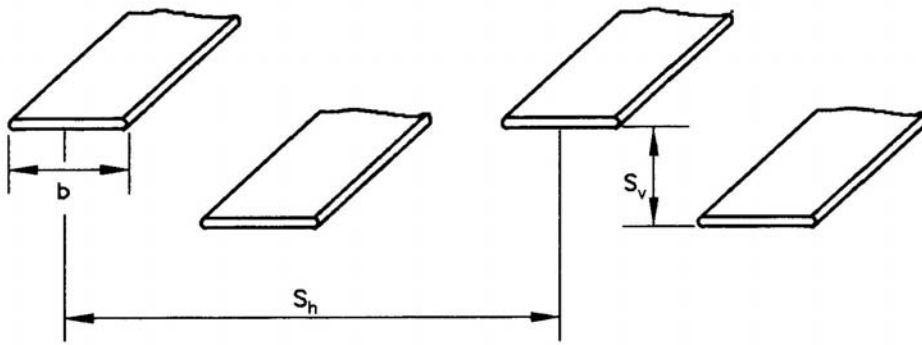

Continuous Geosynthetic reinforcement sheets:

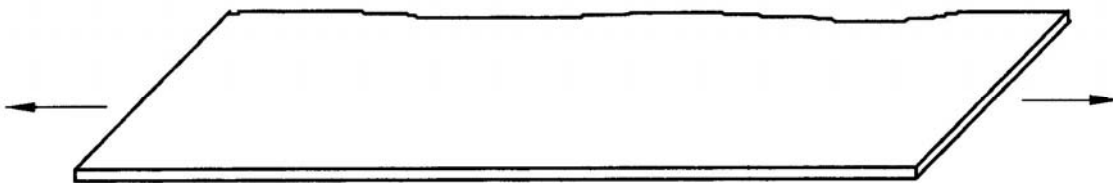

$$R_c = \text{reinforcement coverage ratio} = \frac{b}{S_h}$$

Use $R_c = 1$ for continuous geosynthetic sheets (i.e., $S_h = b = 1$ unit width)

Figure 11.10.6.4.1-2—Reinforcement Coverage Ratio for Geosynthetic Reinforcement

11.10.6.4.2—Design Life Considerations

The provisions of Article 11.5.1 shall apply.

11.10.6.4.2a—Steel Reinforcements

Steel soil reinforcements shall comply with the provisions of *AASHTO LRFD Bridge Construction Specifications*, Article 7.6.4.2, “Steel Reinforcements.”

The structural design of steel soil reinforcements and connections shall be made on the basis of a thickness, E_c , as follows:

$$E_c = E_n - E_s \tag{11.10.6.4.2a-1}$$

where:

E_c = thickness of metal reinforcement at end of service life as shown in Figure 11.10.6.4.1-1 (mil.)

E_n = nominal thickness of steel reinforcement at construction (mil.)

C11.10.6.4.2a

Corrosion loss rates summarized in Yannas (1985) and supplemented by field data developed under other FHWA research studies have been used to establish the sacrificial thicknesses herein.

The backfill specifications contained in *AASHTO LRFD Bridge Construction Specifications*, Section 7, for MSE structures using steel reinforcements present minimum electrochemical requirements, which will generally ensure a mild to moderate potential for corrosion. Where deicing salts are used, adequate drainage provisions for salt laden runoff is required. In some cases, an impervious membrane may be required between the pavement structure and the select backfill. Criteria for evaluating potential corrosion losses are given in Elias et. al (2009).

E_s = sacrificial thickness of metal expected to be lost by uniform corrosion during service life of structure (mil.)

For structural design, sacrificial thicknesses shall be computed for each exposed surface as follows, assuming that the soil backfill used is nonaggressive:

- Loss of galvanizing = 0.58 mil./yr. for first 2 years
= 0.16 mil./yr. for subsequent years
- Loss of carbon steel = 0.47 mil./yr. after zinc depletion

Soils shall typically be considered nonaggressive if they meet the following criteria:

- pH = 5 to 10
- Resistivity ≥ 3000 ohm-cm
- Chlorides ≤ 100 ppm
- Sulfates ≤ 200 ppm
- Organic Content ≤ 1 percent

If the resistivity is greater than or equal to 5000 ohm-cm, the chlorides and sulfates requirements may be waived. For bar mat or grid-type reinforcements, the sacrificial thickness listed above shall be applied to the radius of the wire or bar when computing the cross-sectional area of the steel remaining after corrosion losses.

Transverse and longitudinal grid members shall be sized in accordance with ASTM A185. The transverse wire diameter shall be less than or equal to the longitudinal wire diameter.

Galvanized coatings shall be a minimum of 2 oz./ft² or 3.4 mils. in thickness, applied in conformance to AASHTO M 111M/M 111 (ASTM A123/A 123M) for strip-type reinforcements or ASTM A641 for bar mat or grid-type steel reinforcement.

These sacrificial thicknesses account for potential pitting mechanisms and much of the uncertainty due to data scatter, and are considered to be maximum anticipated losses for soils which are defined as nonaggressive.

Recommended test methods for soil chemical property determination include AASHTO T 289 I for pH, AASHTO T 288 I for resistivity, AASHTO T 291 I for chlorides and AASHTO T 290 I for sulfates.

These sacrificial thickness requirements are not applicable for soils which do not meet one or more of the nonaggressive soil criteria. Additionally, these sacrificial thickness requirements are not applicable in applications where:

- The MSE wall will be exposed to a marine or other chloride rich environment,
- The MSE wall will be exposed to stray currents such as from nearby underground power lines or adjacent electric railways,
- The backfill material is aggressive, or
- The galvanizing thickness is less than specified in these guidelines.

Each of these situations creates a special set of conditions which should be specifically analyzed by a corrosion specialist. Alternatively, noncorrosive reinforcing elements can be considered. Furthermore, these corrosion rates do not apply to other metals. The use of alloys such as aluminum and stainless steel is not recommended.

Requiring the transverse wire diameter to be less than or equal to the longitudinal wire diameter will preclude local overstressing of the longitudinal wires.

Corrosion-resistant coatings should generally be limited to galvanization.

There is insufficient evidence at this time regarding the long-term performance of epoxy coatings for these coatings to be considered equivalent to galvanizing. If epoxy-type coatings are used, they should meet the requirements of ASTM A884 for bar mat and grid reinforcements, or AASHTO M 284M/M 284 for strip reinforcements, and have a minimum thickness of 16 mils.

11.10.6.4.2b—Geosynthetic Reinforcements

Within specific limits of wall application, soil conditions, and polymer type, strength degradation due to environmental factors can be anticipated to be minimal and relatively consistent from product-to-product, and the impact of any degradation which does occur will be minimal. This allows application of a single default reduction factor, *RF*, to the ultimate tensile strength to account for long-term strength losses, as described in Article 11.10.6.4.3b.

Where wall application limits, soil aggressiveness and polymer requirements are consistent with the conditions below, a single default reduction factor specified herein may be used:

- Poor performance of failure will not have severe consequences
 - The soil is considered nonaggressive
 - The polymer material meets the requirements provided in Table 11.10.6.4.2b-1
- 1) *Structure Application Issues*: Identification of applications for which the consequences of poor performance or failure are severe shall be as described in Article 11.5.1. In such applications, a single default reduction factor shall not be used for final design.
 - 2) *Determination of Soil Aggressiveness*: Soil aggressiveness for geosynthetics shall be assessed based on the soil pH, gradation, plasticity, organic content, and in-ground temperature. Soil shall be defined as nonaggressive if the following criteria are met:
 - pH, as determined by AASHTO T 289, $I = 4.5$ to 9 for permanent applications and 3 to 10 for temporary applications,
 - Maximum soil particle size is less than 0.75 in., unless full scale installation damage tests are conducted in accordance with ASTM D5818,
 - Soil organic content, as determined by AASHTO T 267 for material finer than the 0.0787 in. (No. 10) sieve ≤ 1 percent, and
 - Design temperature at wall site:
 - $\leq 86^{\circ}\text{F}$ for permanent applications
 - $\leq 95^{\circ}\text{F}$ for temporary applications

Soil backfill not meeting these requirements as provided herein shall be considered to be aggressive. The environment at the face, in addition to that within the wall backfill, shall be evaluated, especially if the stability of the facing is dependent on the strength of the geosynthetic at the face, i.e., the geosynthetic

C11.10.6.4.2b

The durability of geosynthetic reinforcement is influenced by environmental factors such as time, temperature, mechanical damage, stress levels and chemical exposure, e.g., oxygen, water, and pH, which are the most common chemical factors. Microbiological attack may also affect certain polymers, although not most polymers used for carrying load in soil reinforcement applications. The effects of these factors on product durability are dependent on the polymer type used, i.e., resin type, grade, additives, and manufacturing process, and the macrostructure of the reinforcement. Not all of these factors will have a significant effect on all geosynthetic products. Therefore, the response of geosynthetic reinforcements to these long-term environmental factors is product specific.

The effective design temperature is defined as the temperature which is halfway between the average yearly air temperature and the normal daily air temperature for the warmest month at the wall site. Note that for walls which face the sun, it is possible that the temperature immediately behind the facing could be higher than the air temperature. This condition should be considered when assessing the design temperature, especially for wall sites located in warm, sunny climates.

reinforcement forms the primary connection between the body of the wall and the facing.

The chemical properties of the native soil surrounding the mechanically stabilized soil backfill shall also be considered if there is potential for seepage of groundwater from the native surrounding soils to the mechanically stabilized backfill. If this is the case, the surrounding soils shall also meet the chemical criteria required for the backfill material if the environment is to be considered nonaggressive, or adequate long-term drainage around the geosynthetic reinforced mass shall be provided to ensure that chemically aggressive liquid does not enter into the reinforced backfill.

- 3) *Polymer Requirements*: Polymers which are likely to have good resistance to long-term chemical degradation shall be used if a single default reduction factor is to be used, to minimize the risk of the occurrence of significant long-term degradation. The polymer material requirements provided in Table 11.10.6.4.2b-1 shall, therefore, be met if detailed product specific data as described in AASHTO PP 66 and Elias, et al. (2009) is not obtained. Polymer materials not meeting the requirements in Table 11.10.6.4.2b-1 may be used if this detailed product specific data extrapolated to the design life intended for the structure are obtained.

For applications involving:

- Severe consequences of poor performance or failure,
- Aggressive soil conditions,
- Polymers not meeting the specific requirements set in Table 11.10.6.4.2b-1, or
- A desire to use an overall reduction factor less than the default reduction factor recommended herein,

then product-specific durability studies shall be carried out prior to product use to determine the product-specific long-term strength reduction factor, *RF*. These product-specific studies shall be used to estimate the short-term and long-term effects of these environmental factors on the strength and deformational characteristics of the geosynthetic reinforcement throughout the reinforcement design life.

Guidelines for product-specific studies to determine *RF* are provided in Elias et al. (2001) and Elias (2000).

Guidelines for product-specific studies to determine *RF* are provided in Elias et al. (2009) and AASHTO PP 66, a provisional standard that is based on WSDOT Standard Practice T925 (WSDOT, 2009). Independent product-specific data from which *RF* may be determined can be obtained from the AASHTO National Transportation Product Evaluation Program (NTPEP) website at <http://www.ntpep.org>.

Table 11.10.6.4.2b-1—Minimum Requirements for Geosynthetic Products to Allow Use of Default Reduction Factor for Long-Term Degradation

Polymer Type	Property	Test Method	Criteria to Allow Use of Default <i>RF</i>
Polypropylene	UV Oxidation Resistance	ASTM D4355	Minimum 70% strength retained after 500 hrs. in weatherometer
Polyethylene	UV Oxidation Resistance	ASTM D4355	Minimum 70% strength retained after 500 hrs. in weatherometer
Polypropylene	Thermo-Oxidation Resistance	ENV ISO 13438:1999, Method A	Minimum 50% strength retained after 28 days
Polyethylene	Thermo-Oxidation Resistance	ENV ISO 13438:1999, Method B	Minimum 50% strength retained after 56 days
Polyester	Hydrolysis Resistance	Intrinsic Viscosity Method (ASTM D4603) and GRI Test Method GG8, or Determine Directly Using Gel Permeation Chromatography	Minimum Number Average Molecular Weight of 25000
Polyester	Hydrolysis Resistance	ASTM D7409	Maximum of Carboxyl End Group Content of 30
All Polymers	Survivability	Weight per Unit Area (ASTM D5261)	Minimum 270 g/m ²
All Polymers	% Post-Consumer Recycled Material by Weight	Certification of Materials Used	Maximum of 0%

11.10.6.4.3—Design Tensile Resistance

11.10.6.4.3a—Steel Reinforcements

The nominal reinforcement tensile resistance is determined by multiplying the yield stress by the cross-sectional area of the steel reinforcement after corrosion losses (see Figure 11.10.6.4.1-1). The loss in steel cross-sectional area due to corrosion shall be determined in accordance with Article 11.10.6.4.2a. The reinforcement tensile resistance shall be determined as:

$$T_{al} = \frac{A_c F_y}{b} \quad (11.10.6.4.3a-1)$$

where:

- T_{al} = nominal long-term reinforcement design strength (kips/ft)
- F_y = minimum yield strength of steel (ksi)
- A_c = area of reinforcement corrected for corrosion loss (Figure 11.10.6.4.1-1) (in.²)
- b = unit width of reinforcement (Figure 11.10.6.4.1-1) (ft)

11.10.6.4.3b—Geosynthetic Reinforcements

The nominal long-term reinforcement tensile strength shall be determined as:

C11.10.6.4.3b

T_{al} is the long-term tensile strength required to prevent rupture calculated on a load per unit of reinforcement width basis. T_{ult} is the ultimate tensile

$$T_{al} = \frac{T_{ult}}{RF} \quad (11.10.6.4.3b-1)$$

where:

$$RF = RF_{ID} \times RF_{CR} \times RF_D \quad (11.10.6.4.3b-2)$$

and:

- T_{al} = nominal long-term reinforcement design strength (kips/ft)
- T_{ult} = minimum average roll value (MARV) ultimate tensile strength (kips/ft)
- RF = combined strength reduction factor to account for potential long-term degradation due to installation damage, creep and chemical aging (dim.)
- RF_{ID} = strength reduction factor to account for installation damage to reinforcement (dim.)
- RF_{CR} = strength reduction factor to prevent long-term creep rupture of reinforcement (dim.)
- RF_D = strength reduction factor to prevent rupture of reinforcement due to chemical and biological degradation (dim.)

Values for RF_{ID} , RF_{CR} , and RF_D shall be determined from product specific test results as specified in Article 11.10.6.4.2b. Even with product specific test results, neither RF_{ID} nor RF_D shall be less than 1.1.

strength of the reinforcement determined from wide width tensile tests specified in ASTM D4595 for geotextiles and ASTM D6637 for geogrids. The value selected for T_{ult} is the minimum average roll value (MARV) for the product to account for statistical variance in the material strength.

Guidelines for determination of RF_{ID} , RF_{CR} , and RF_D from product-specific data are provided in AASHTO PP 66 and Elias et al. (2009). PP 66 is based on WSDOT Standard Practice T925 (WSDOT, 2009). Independent product-specific data from which RF_{ID} , RF_{CR} , and RF_D may be determined can be obtained from the AASHTO National Transportation Product Evaluation Program (NTPEP) website at <http://www.ntpep.org>.

Note that RF_D is generally not based on long-term performance testing unless the soil is considered to be chemically aggressive. Instead, for typical soil defined as chemically nonaggressive, the index tests and criteria identified in Table 11.10.6.4.2b-1 are used to establish a default value for RF_D that can be used in combination with the product specific values of RF_{ID} and RF_{CR} to determine a product specific value of RF to use for design. For products meeting the requirements in Table 11.10.6.4.2b-1 used in chemically nonaggressive soil, a default value of RF_D of 1.3 may be used (AASHTO, 2010; WSDOT, 2009; Berg, et al., 2009). Additional guidance on the selection of RF_D is provided in Berg, et al. (2009).

For wall applications which are defined as not having severe consequences should poor performance or failure occur, having nonaggressive soil conditions, and if the geosynthetic product meets the minimum requirements listed in Table 11.10.6.4.3b-1, the long-term tensile strength of the reinforcement may be determined using a default reduction factor for RF as provided in Table 11.10.6.4.3b-1 in lieu of product-specific test results.

Table 11.10.6.4.3b-1—Default and Minimum Values for the Total Geosynthetic Ultimate Limit State Strength Reduction Factor, RF

Application	Total Reduction Factor, RF
All applications, but with product-specific data obtained and analyzed in accordance with AASHTO PP 66	All reduction factors shall be based on product specific data. Neither RF_{ID} nor RF_D shall be less than 1.1.
Permanent applications not having severe consequences should poor performance or failure occur, nonaggressive soils, and polymers meeting the requirements listed in Table 11.10.6.4.2b-1	7.0
Temporary applications not having severe consequences should poor performance or failure occur, nonaggressive soils, and polymers meeting the requirements listed in Table 11.10.6.4.2b-1 provided product-specific data are not available	3.5

11.10.6.4.4—Reinforcement/Facing Connection Design Strength

11.10.6.4.4a—Steel Reinforcements

Connections shall be designed to resist stresses resulting from active forces, T_o , in Article 11.10.6.2.2, as well as from differential movements between the reinforced backfill and the wall facing elements.

Elements of the connection which are embedded in the facing element shall be designed with adequate bond length and bearing area in the concrete to resist the connection forces. The capacity of the embedded connector shall be checked by tests as required in Article 5.11.3. Connections between steel reinforcement and the wall facing units, e.g., welds, bolts, pins, etc., shall be designed in accordance with Article 6.13.3.

Connection materials shall be designed to accommodate losses due to corrosion in accordance with Article 11.10.6.4.2a. Potential differences between the environment at the face relative to the environment within the reinforced soil mass shall be considered when assessing potential corrosion losses.

11.10.6.4.4b—Geosynthetic Reinforcements

The portion of the connection embedded in the concrete facing shall be designed in accordance with Article 5.11.3.

The nominal long-term geosynthetic connection strength T_{ac} on a load per unit reinforcement width basis shall be determined as follows:

$$T_{ac} = \frac{T_{ult} \times CR_{cr}}{RF_D} \quad (11.10.6.4.4b-1)$$

where:

T_{ac} = nominal long-term reinforcement/facing connection design strength per unit of reinforcement width at a specified confining pressure (kips/ft)

C11.10.6.4.4b

The long-term creep reduced geosynthetic strength at the connection with the wall facing is obtained by reducing T_{ult} by CR_{cr} using the connection/seam strength determined in accordance with long-term connection strength test protocol as described in Appendix A of Elias et al. (2001). The connection test is similar in nature to a wide width tensile test (ASTM D4595 or ASTM D6637), except that one end of the reinforcement material is sandwiched between two courses of concrete blocks to form one of the grips. This protocol consists of a series of connection creep tests carried out over an extended period of time to evaluate the potential for creep rupture at the connection. CR_{cr} is taken as the creep reduced connection strength, T_{crc} , extrapolated to the specified design life, divided by the ultimate wide width tensile strength (ASTM D4595 or D6637) for the reinforcement material lot used for the connection strength testing, T_{lot} .

T_{ult}	=	minimum average roll value (MARV) ultimate tensile strength of soil reinforcement (kips/ft)
CR_{cr}	=	long-term connection strength reduction factor to account for reduced ultimate strength resulting from connection (dim.)
RF_D	=	reduction factor to prevent rupture of reinforcement due to chemical and biological degradation (Article 11.10.6.4.3b) (dim.)

CR_{cr} may also be obtained from short-term connection test (ASTM D4884 for seam connections, or NCMA Test Method SRWU-1 in Simac et al. (1993) for segmental concrete block connections) results, which are to obtain a short-term ultimate connection strength reduction factor CR_u . CR_u is taken as the ultimate connection strength $T_{ultconn}$ from SRWU-1 or ASTM D4884, divided by T_{lot} as described above. In this case, CR_u must be further reduced by the creep reduction factor RF_{CR} (Article 11.10.6.4.3b) in order to account for the potential of creep rupture as follows:

$$CR_{cr} = \frac{CR_u}{RF_{CR}} \quad (C11.10.6.4.4b-1)$$

For reinforcements connected to the facing through embedment between facing elements, e.g., segmental concrete block faced walls, the capacity of the connection is conceptually governed by one of two failure modes: rupture, or pullout of the reinforcement. This is consistent with the evaluation of internal wall stability in the reinforced backfill zone, where both the rupture and pullout mode of failure must be considered.

The objective of the connection design is to assess the long-term capacity of the connection. If rupture is the mode of failure, the long-term effects of creep and durability on the geosynthetic reinforcement at the connection, as well as on the connector materials, must be taken into account, as the capacity of the connection is controlled by the reinforcement or connector long-term strength. If pullout is the mode of failure, the capacity of the connection is controlled by the frictional interface between the facing blocks and the geosynthetic reinforcement. It is assumed for design that this interface is not significantly affected by time dependent mechanisms such as creep or chemical degradation. This again is consistent with the design of the soil reinforcement within the wall backfill. The load bearing fibers or ribs of the geosynthetic do not necessarily have to experience rupture in the connection test for the mode of failure to be rupture. If the connector is a material that is susceptible to creep, failure of the connectors between blocks due to creep rupture of the connector could result in long-term connection strength losses. In these cases, the value of CR_{cr} and RF_D to be used in Eq. C11.10.6.4.4b-1 should be based on the durability of the connector, not the geosynthetic.

Regardless of the failure mode, the long-term connection test referenced in Elias et al. (2001) addresses the long-term capacity of the connection. Eq. C11.10.6.4.4b-1 above should also be considered to conservatively apply to both failure modes, if the long-term connection test is not performed.

If the connectors between blocks are intended to be used for maintaining block alignment during wall construction and are not intended for long-term connection shear capacity, the alignment connectors should be removed before assessing the connection capacity for the selected block-geosynthetic combination. If the pins or other connection devices are to be relied upon for long-term capacity, the durability of the connector material must be established.

Values for RF_{CR} and RF_D shall be determined from product-specific test results, except as otherwise specified herein. The environment at the wall face connection may be different than the environment away from the wall face in the wall backfill. This shall be considered when determining RF_{CR} and RF_D .

CR_{cr} shall be determined at the anticipated vertical confining pressure at the wall face between the facing blocks. The vertical confining pressure shall be calculated using the Hinge Height Method as shown in Figure 11.10.6.4.4b-1 for a face batter, ω , of greater than 8 degrees. T_{ac} should not be greater than T_{at} .

Geosynthetic walls may be designed using a flexible reinforcement sheet as the facing using only an overlap with the main soil reinforcement. The overlaps shall be designed using a pullout methodology. By replacing T_{max} with T_o , Eq. 11.10.6.3.2-1 may be used to determine the minimum overlap length required, but in no case shall the overlap length be less than 3.0 ft. If ρ is determined experimentally based on soil to reinforcement contact, $\tan \rho$ shall be reduced by 30 percent where reinforcement to reinforcement contact is anticipated.

Requirements for determining RF_{CR} and RF_D from product-specific data are provided in Article 11.10.6.4.3b and its commentary. The use of default reduction factors may be acceptable where the reinforcement load is maximum, i.e., in the middle of the wall backfill, and still not be acceptable at the facing connection if the facing environment is defined as aggressive.

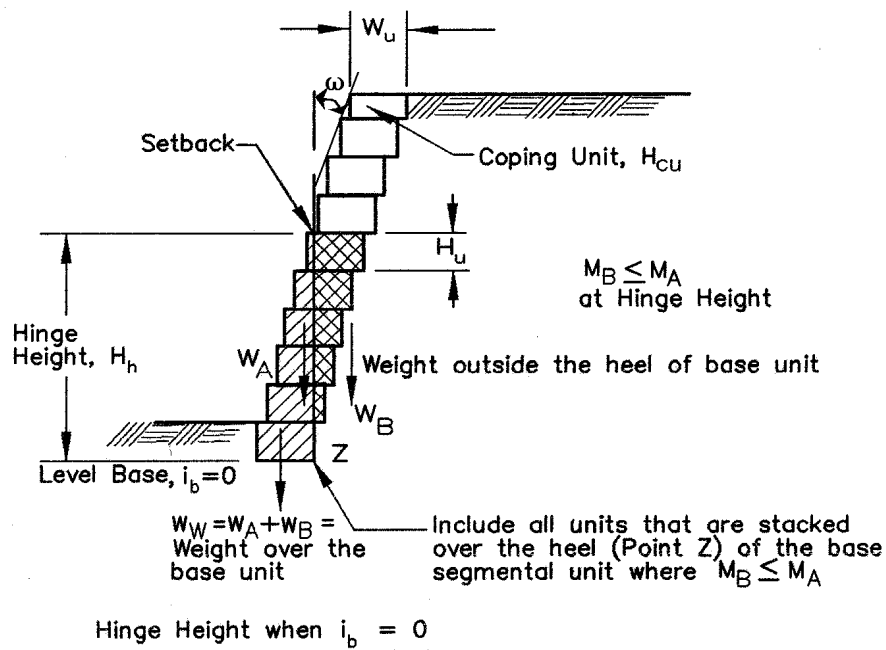

Hinge Height, H_h . The full weight of all segmental facing block units within H_h will be considered to act at the base of the lowermost segmental facing block.

Figure 11.10.6.4.4b-1—Determination of Hinge Height for Segmental Concrete Block Faced MSE Walls

The hinge height, H_h , shown in Figure 11.10.6.4.4b-1, shall be determined as:

$$H_h = 2[(W_u - G_u - 0.5H_u \tan i_b) \cos i_b] / \tan(\omega + i_b) \quad (11.10.6.4.4b-2)$$

where:

- H_u = segmental facing block unit height (ft)
- W_u = segmental facing block unit width, front to back (ft)
- G_u = distance to the center of gravity of a horizontal segmental facing block unit, including aggregate fill, measured from the front of the unit (ft)
- ω = wall batter due to setback per course (degrees)
- H = total height of wall (ft)
- H_h = hinge height (ft)

11.10.7—Seismic Design of MSE Walls

11.10.7.1—External Stability

External stability evaluation of MSE walls for seismic loading conditions shall be conducted as specified in Article 11.6.5, except as modified in this Article for MSE wall design.

Wall mass inertial forces (P_{IR}) shall be calculated based on an effective mass having a minimum width equal to the structural facing width (W_u) plus a portion of the reinforced backfill equal to 50 percent of the effective height of the wall. For walls in which the wall backfill surface is horizontal, the effective height shall be taken equal to H in Figure 11.10.7.1-1. For walls with sloping backfills, the inertial force, P_{IR} , shall be based on an effective mass having a height H_2 and a base width equal to a minimum of $0.5 H_2$, in which H_2 is determined as follows:

$$H_2 = H + \frac{0.5H \tan(\beta)}{[1 - 0.5 \tan(\beta)]} \quad (11.10.7.1-1)$$

where:

β = slope of backfill (degrees)

P_{IR} for sloping backfills shall be determined as:

$$P_{IR} = P_{ir} + P_{is} \quad (11.10.7.1-2)$$

where:

P_{ir} = the inertial force caused by acceleration of the reinforced backfill (kips/ft)

P_{is} = the inertial force caused by acceleration of the sloping soil surcharge above the reinforced backfill (kips/ft)

P_{IR} shall act at the combined centroid of reinforced wall mass inertial force, P_{ir} , and the inertial force resulting from the mass of the soil surcharge above the reinforced wall volume, P_{is} . P_{ir} shall include the inertial force from the wall facing. The determination of the MSE wall inertial forces shall be as illustrated in Figure 11.10.7.1-1.

C11.10.7.1

Since the reinforced soil mass is not really a rigid block, the inertial forces generated by seismic shaking are unlikely to peak at the same time in different portions of the reinforced mass when reinforcing strips or layers start becoming very long, as in the case of MSE walls with steep backslopes in moderately- to-highly seismic areas. This introduces excessive conservatism if the full length of the reinforcing strips is used in the inertia determination. Past design practice, as represented in previous editions of these Specifications, recommended that wall mass inertial force be limited to a soil volume equal to 50 percent of the effective height of the wall.

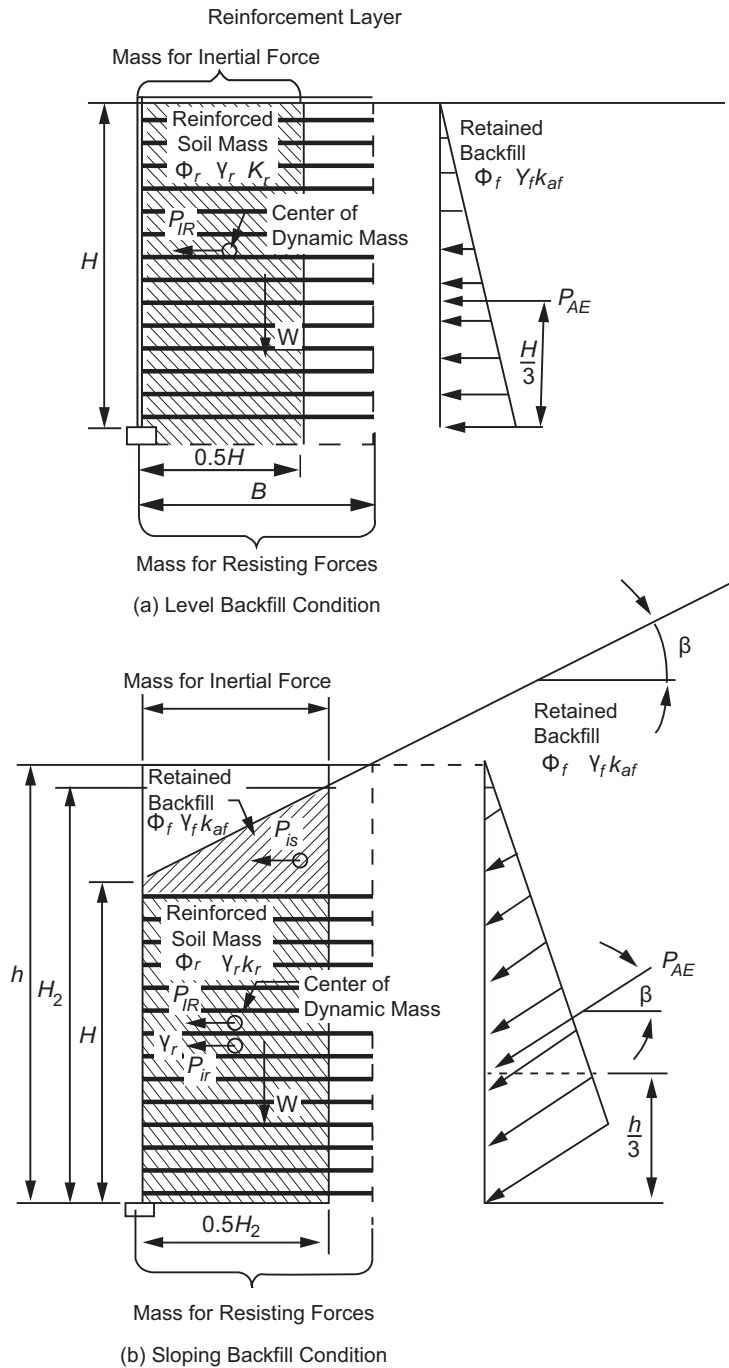

Figure 11.10.7.1-1—Seismic External Stability of an MSE Wall

11.10.7.2—Internal Stability

Reinforcements shall be designed to withstand horizontal forces generated by the internal inertia force, P_{is} , and the static forces. The total inertia force, P_{is} , per unit length of structure shall be considered equal to the mass of the active zone times the wall acceleration coefficient, k_{is} , reduced for lateral displacement of the wall during shaking. The reduced acceleration coefficient, k_{is} , should be consistent with the value of k_h used for external stability.

C11.10.7.2

In past design practice, as presented in previous editions of these Specifications, the design method for seismic internal stability assumes that the internal inertia forces generating additional tensile loads in the reinforcement act on an active pressure zone that is assumed to be the same as that for the static loading case. A bilinear zone is defined for inextensible reinforcements such as metallic strips and a linear zone for extensible strips.

For walls with inextensible (e.g., steel) reinforcement, this inertial force shall be distributed to the reinforcements proportionally to their resistant areas on a load per unit width of wall basis as follows:

$$T_{md} = \gamma P_i \frac{L_{ei}}{\sum_{i=1}^m (L_{ei})} \quad (11.10.7.2-1)$$

For walls with extensible reinforcement, this inertial force shall be distributed uniformly to the reinforcements on a load per unit width of wall basis as follows:

$$T_{md} = \gamma \left(\frac{P_i}{n} \right) \quad (11.10.7.2-2)$$

where:

- T_{md} = factored incremental dynamic inertia force at Layer i (kips/ft)
- γ = load factor for EQ loads from Table 3.4.1-1 (dim.)
- P_i = internal inertia force due to the weight of backfill within the active zone, i.e., the shaded area on Figure 11.10.7.2-1 (kips/ft)
- $K_h W_a$ = where W_a is the weight of the active zone and K_h is calculated as specified in Article 11.6.5.1.
- n = total number of reinforcement layers in the wall (dim)
- L_{ei} = effective reinforcement length for layer i (ft)

This pressure distribution should be determined from the total inertial force using k_h (after reduction for wave scattering and lateral displacement).

The total factored load applied to the reinforcement on a load per unit of wall width basis as shown in Figure 11.10.7.2-1 is determined as follows:

$$T_{total} = T_{max} + T_{md} \quad (11.10.7.2-3)$$

where:

- T_{max} = the factored static load applied to the reinforcements determined using Eq. 11.10.6.2.1-2.

Whereas it could reasonably be anticipated that these active zones would extend outwards for seismic cases, as for M-O analyses, results from numerical and centrifuge models indicate that the reinforcement restricts such outward movements and only relatively small changes in location are seen.

In past design practice, as presented in previous editions of these Specifications, the total inertial force is distributed to the reinforcements in proportion to the effective resistant lengths, L_{ei} . This approach follows the finite element modeling conducted by Segrestin and Bastick (1988) and leads to higher tensile forces in lower reinforcement layers.

In the case of internal stability evaluation, Vrymoed (1989) used a tributary area approach that assumes that the inertial load carried by each reinforcement layer increases linearly with height above the toe of the wall for equally spaced reinforcement layers. A similar approach was used by Ling et al. (1997) in limit equilibrium analyses as applied to extensible geosynthetic reinforced walls. This concept would suggest that longer reinforcement lengths could be needed at the top of walls with increasing acceleration levels, and the AASHTO approach could be unconservative, at least for geosynthetic reinforced walls. Numerical modeling of both steel and geosynthetic reinforced walls by Bathurst and Hatami (1999) shows that the distribution of the reinforcement load increase caused by seismic loading tends to become more uniform with depth as the reinforcement stiffness decreases, resulting in a uniform distribution for geosynthetic reinforced wall systems and a triangular distribution for typical steel reinforced wall systems. Hence, the Segrestin and Bastick (1988) method has been preserved for steel reinforced wall systems and, for geosynthetic reinforced wall systems, a uniform load distribution approach is specified.

With regard to the horizontal acceleration coefficient, k_h , past editions of these Specifications have not allowed k_h to be reduced to account for lateral deformation. Based on the excellent performance of MSE walls in earthquakes to date, it appears that this is likely a conservative assumption and it is therefore reasonable to allow reduction of k_h for internal stability design corresponding to the lateral displacement permitted in the design of the wall for external stability.

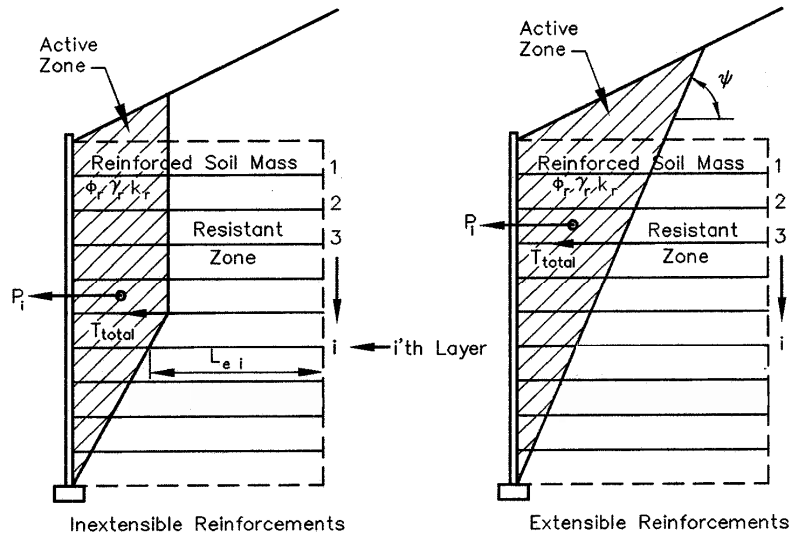

ψ = angle of active zone boundary as determined from Figure 11.10.6.3.1-1.

P_i = Internal inertial force due to the weight of the backfill within the active zone.

$L_{e i}$ = The length of reinforcement in the resistant zone of the i 'th layer.

T_{max} = The factored load per unit wall width applied to each reinforcement layer due to static forces.

T_{md} = The factored load per unit wall width applied to each reinforcement layer due to dynamic forces.

The total factored load per unit wall width applied to each reinforcement layer,

$$T_{total} = T_{max} + T_{md}$$

Figure 11.10.7.2-1—Seismic Internal Stability of an MSE Wall

For geosynthetic reinforcement rupture, the reinforcement shall be designed to resist the static and dynamic components of the load determined as:

For the static component:

$$S_{rs} \geq \frac{T_{max} RF}{\phi R_c} \quad (11.10.7.2-4)$$

For the dynamic component:

$$S_{rt} \geq \frac{T_{md} RF_{ID} RF_D}{\phi R_c} \quad (11.10.7.2-5)$$

where:

- ϕ = resistance factor for combined static/earthquake loading from Table 11.5.7-1 (dim.)
- S_{rs} = ultimate reinforcement tensile resistance required to resist static load component (kips/ft)
- S_{rt} = ultimate reinforcement tensile resistance required to resist dynamic load component (kips/ft)
- R_c = reinforcement coverage ratio specified in Article 11.10.6.4.1 (dim.)
- RF = combined strength reduction factor to account for potential long-term degradation due to installation damage, creep, and chemical aging specified in Article 11.10.6.4.3b (dim.)
- RF_{ID} = strength reduction factor to account for installation damage to reinforcement specified in Article 11.10.6.4.3b (dim.)
- RF_D = strength reduction factor to prevent rupture of reinforcement due to chemical and biological degradation specified in Article 11.10.6.4.3b (dim.)

The required ultimate tensile resistance of the geosynthetic reinforcement shall be determined as:

$$T_{ult} = S_{rs} + S_{rt} \quad (11.10.7.2-6)$$

For pullout of steel or geosynthetic reinforcement:

$$L_e \geq \frac{T_{total}}{\phi (0.8F^* \alpha \sigma_v C R_c)} \quad (11.10.7.2-7)$$

The reinforcement must be designed to resist the dynamic component of the load at any time during its design life. Design for static loads requires the strength of the reinforcement at the end of the design life to be reduced to account for creep and other degradation mechanisms. Strength loss in polymeric materials due to creep requires long term, sustained loading. The dynamic component of load for seismic design is a transient load and does not cause strength loss due to creep. The resistance of the reinforcement to the static component of load, T_{max} , must, therefore, be handled separately from the dynamic component of load, T_{md} . The strength required to resist T_{max} must include the effects of creep, but the strength required to resist T_{md} should not include the effects of creep.

where:

L_e	=	length of reinforcement in resisting zone (ft)
T_{total}	=	maximum factored reinforcement tension from Eq. 11.10.7.2-2 (kips/ft)
ϕ	=	resistance factor for reinforcement pullout from Table 11.5.7-1 (dim.)
F^*	=	pullout friction factor (dim.)
α	=	scale effect correction factor (dim.)
σ_v	=	unfactored vertical stress at the reinforcement level in the resistant zone (ksf)
C	=	overall reinforcement surface area geometry factor (dim.)
R_c	=	reinforcement coverage ratio specified in Article 11.10.6.4.1 (dim.)

For seismic loading conditions, the value of F^* , the pullout resistance factor, shall be reduced to 80 percent of the value used for static design, unless dynamic pullout tests are performed to directly determine the F^* value.

11.10.7.3—Facing Reinforcement Connections

C11.10.7.3

Facing elements shall be designed to resist the seismic loads determined as specified in Article 11.10.7.2, i.e., T_{total} . Facing elements shall be designed in accordance with applicable provisions of Sections 5, 6, and 8 for reinforced concrete, steel, and timber, respectively, except that for the Extreme Event I limit state, all resistance factors should be 1.0, unless otherwise specified for this limit state.

For segmental concrete block faced walls, the blocks located above the uppermost backfill reinforcement layer shall be designed to resist toppling failure during seismic loading.

For geosynthetic connections subjected to seismic loading, the factored long-term connection strength, ϕT_{ac} , must be greater than $T_{max} + T_{md}$. If the connection strength is partially or fully dependent on friction between the facing blocks and the reinforcement, the connection strength to resist seismic loads shall be reduced to 80 percent of its static value as follows:

For the static component of the load:

$$S_{rs} \geq \frac{T_{max} RF_D}{0.8\phi CR_{cr} R_c} \quad (11.10.7.3-1)$$

For the dynamic component of the load:

$$S_{rt} \geq \frac{T_{md} RF_D}{0.8\phi CR_u R_c} \quad (11.10.7.3-2)$$

where:

- S_{rs} = ultimate reinforcement tensile resistance required to resist static load component (kip/ft)
- T_{max} = applied load to reinforcement (kip/ft)
- RF_D = reduction factor to prevent rupture of reinforcement due to chemical and biological degradation specified in Article 11.10.6.4.4b (dim.)
- ϕ = resistance factor from Table 11.5.7-1 (dim.)
- CR_{cr} = long-term connection strength reduction factor to account for reduced ultimate strength resulting from connection (dim.)
- R_c = reinforcement coverage ratio from Article 11.10.6.4.1 (dim.)
- S_{rt} = ultimate reinforcement tensile resistance required to resist dynamic load component (kip/ft)
- T_{md} = factored incremental dynamic inertia force (kip/ft)
- CR_u = short-term reduction factor to account for reduced ultimate strength resulting from connection as specified in Article C11.10.6.4.4b (dim.)

For mechanical connections that do not rely on a frictional component, the 0.8 multiplier may be removed from Eqs. 11.10.7.3-1 and 11.10.7.3-2.

The required ultimate tensile resistance of the geosynthetic reinforcement at the connection is:

$$T_{ult} = S_{rs} + S_{rt} \quad (11.10.7.3-3)$$

For structures in seismic performance Zones 3 or 4, facing connections in segmental block faced walls shall use shear resisting devices between the facing blocks and soil reinforcement such as shear keys, pins, etc., and shall not be fully dependent on frictional resistance between the soil reinforcement and facing blocks.

The connection capacity of a facing/reinforcement connection system that is fully dependent on the shear resisting devices for the connection capacity will not be significantly influenced by the normal stress between facing blocks. The percentage of connection load carried by the shear resisting devices relative to the frictional resistance to meet the specification requirements should be determined based on past successful performance of the connection system.

Some judgment may be required to determine whether or not a specific shear resisting device or combination of devices is sufficient to meet this requirement in Seismic Performance Zones 3 and 4. The ability of the shear resisting device or devices to keep the soil reinforcement connected to the facing, should vertical acceleration significantly reduce the normal force between the reinforcement and the facing blocks, should be evaluated. Note that in some cases, coarse angular gravel placed within the hollow core of the facing blocks, provided that the gravel can remain interlocked during shaking, can function as a shear restraining device to meet the requirements of this Article.

11.10.7.4—Wall Details for Improved Seismic Performance

The details specified in Article 11.6.5.6 for gravity walls should also be addressed for MSE walls in seismically active areas, defined as Seismic Zone 2 or higher. The following additional requirements should also be addressed for MSE walls:

- *Second Stage Fascia Panels:* The connections used to connect the fascia panels to the main gravity wall structure should be designed to minimize movement between panels during shaking.
- *Soil Reinforcement Length:* A minimum soil reinforcement length of $0.7H$ should be used. A greater soil reinforcement length in the upper 2 to 4.0 ft of wall height (a minimum of two reinforcement layers) should also be considered to improve the seismic performance of the wall. If the wall is placed immediately in front of a very steep slope, existing shoring, or permanent wall, the reinforcement within the upper 2.0 to 4.0 ft of wall height (a minimum of two reinforcement layers, applicable to wall heights of 10.0 ft or more) should be extended to at least 5.0 ft behind the steep slope or existing wall.
- *Wall Corners and Abrupt Facing Alignment Changes:* Should be designed using specially formed facing units to bridge across the corner and overlap with the adjacent wall facing units to prevent the corner from opening up during shaking. Wall corners should also be designed for the potential for higher loads to develop than would be determined using two-dimensional analysis. Wall corners and short radius turns are defined as having an enclosed angle of 120 degrees or less.

C11.10.7.4

These recommended details are based on previous experiences with walls in earthquakes (e.g., see Yen et al., 2011). Walls that did not address these details tended to have a higher frequency of problems than walls that did consider these details.

With regard to preventing joints from opening up during shaking, corners details, and details for addressing protrusions through the wall face, Article C11.6.5.6 applies. For panel-faced MSE walls placed against a cast-in-place (CIP) concrete curtain wall or similar structure, a 4.0-in. lip on the CIP structure to cover the joint with the MSE wall facing has been used successfully.

Regarding the design of wall corners and abrupt changes in the facing alignment (e.g., corners and short radius turns at an enclosed angle of 120 degrees or less), both static and seismic earth pressure loading may be greater than what would be determined from two-dimensional analysis. Historically, corners and abrupt alignment changes in walls have had a higher incidence of performance problems during earthquakes than relatively straight sections of the wall alignment, as the corners tend to attract dynamic load and increased earth pressures. This should be considered when designing a wall corner for seismic loading. For that portion of the corner or abrupt wall facing alignment change where the soil reinforcement cannot achieve its full length required to meet internal stability requirements, the end of the reinforcement layer should be structurally tied to the back of the adjacent panel. Reinforcement layers should be placed in both directions. In addition, the special corner facing element should also have reinforcement layers attached to it to provide stability for the corner panel. The reinforcement layers that are tied to both sides of the corner should be designed for the higher earth pressures considering the corner as a bin structure.

Note that the corner or abrupt alignment change enclosed angle as defined in the previous paragraph can either be internal or external to the wall.

With regard to wall backfill materials, the provisions of Article 11.6.5.6 shall apply.

When structures and foundations within the active zone of the reinforced wall backfill are present significant wall movements and damage have occurred during earthquakes due to inadequate reinforcement length behind the facing due to the presence of a foundation, drainage structure, or other similar structure. The details provided in Article 11.10.10.4 are especially important to implement for walls subjected to seismic loading.

Past experience with second stage precast incremental facing panels indicates that performance problems can occur if the connections between the panels and the first stage wall can rotate or otherwise have some looseness, especially if wall settlement is not complete. Therefore, incremental second stage fascia

panels should be avoided for walls located in seismically active areas. Full height second stage precast or cast-in-place concrete panels have performed more consistently, provided the panels are installed after wall settlement is essentially complete.

A minimum soil reinforcement length of $0.7H$ has been shown to consistently provide good performance of MSE walls in earthquakes. Extending the upper two layers of soil reinforcement a few feet behind the $0.7H$ reinforcement length has in general resulted in modest improvement in the wall deformation in response to seismic loading, especially if higher silt content backfill must be used. If MSE walls are placed in front of structures or hard soil or rock steep slopes that could have different deformation characteristics than the MSE wall reinforced backfill, there is a tendency for a crack to develop at the vertical or near-vertical boundary of the two materials. Soil reinforcements that extend an adequate distance behind the boundary have been shown to prevent such a crack from developing. It is especially important to extend the length of the upper reinforcement layers if there is inadequate room to have a reinforcement length of $0.7H$ in the bottom portion of the wall, provided the requirements of Article 11.10.2.1 and commentary are met.

For additional information on good wall details for MSE walls, see Berg et al. (2009).

11.10.8—Drainage

Internal drainage measures shall be considered for all structures to prevent saturation of the reinforced backfill and to intercept any surface flows containing aggressive elements.

MSE walls in cut areas and side-hill fills with established groundwater levels shall be constructed with drainage blankets in back of, and beneath, the reinforced zone.

For MSE walls supporting roadways which are chemically deiced in the winter, an impervious membrane may be required below the pavement and just above the first layer of soil reinforcement to intercept any flows containing deicing chemicals. The membrane shall be sloped to drain away from the facing to an intercepting longitudinal drain outletted beyond the reinforced zone. Typically, a roughened surface PVC, HDPE or LLDPE geomembrane with a minimum thickness of 30 mils. should be used. All seams in the membrane shall be welded to prevent leakage.

11.10.9—Subsurface Erosion

The provisions of Article 11.6.3.5 shall apply.

11.10.10—Special Loading Conditions

11.10.10.1—Concentrated Dead Loads

The distribution of stresses within and behind the wall resulting from concentrated loads applied to the wall top or behind the wall shall be determined in accordance with Article 3.11.6.3.

Figure 11.10.10.1-1 illustrates the combination of loads using superposition principles to evaluate external and internal wall stability. Depending on the size and location of the concentrated dead load, the location of the boundary between the active and resistant zones may have to be adjusted as shown in Figure 11.10.10.1-2.

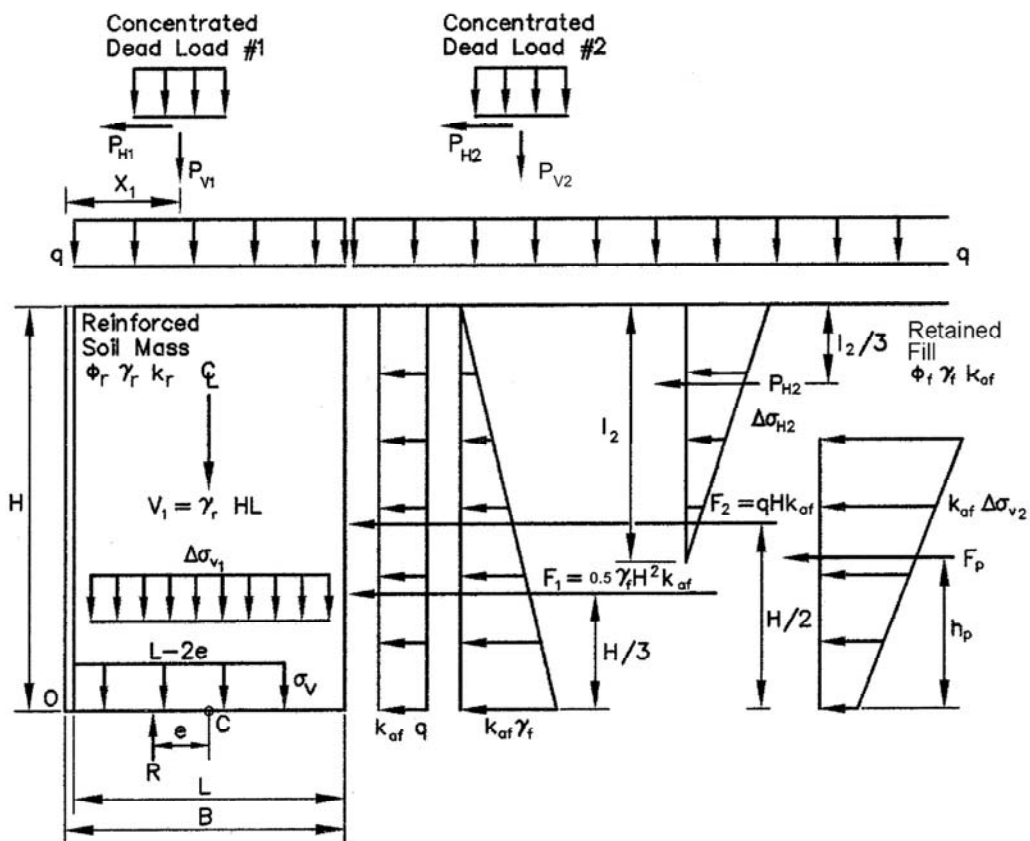

Notes:

These equations assume that concentrated dead load #2 is located within the active zone behind the reinforced soil mass.

For relatively thick facing elements, (e.g., segmental concrete facing blocks), it is acceptable to include the facing dimensions and weight in sliding, overturning, and bearing capacity calculations (i.e., use B in lieu of L).

P_{V1} , P_{H1} , $\Delta\sigma_{v1}$, $\Delta\sigma_{v2}$, $\Delta\sigma_{H2}$, and I_2 are as determined from Figures 3.11.6.3-1 and 3.11.6.3-2, and F_p results from P_{V2} (i.e., $K\Delta\sigma_{v2}$ from Figure 3.11.6.3-1). H is the total wall height at the face. h_p is the distance between the centroid of the trapezoidal distribution shown and the bottom of that distribution.

Figure 11.10.10.1-1—Superposition of Concentrated Dead Loads for External and Internal Stability Evaluation

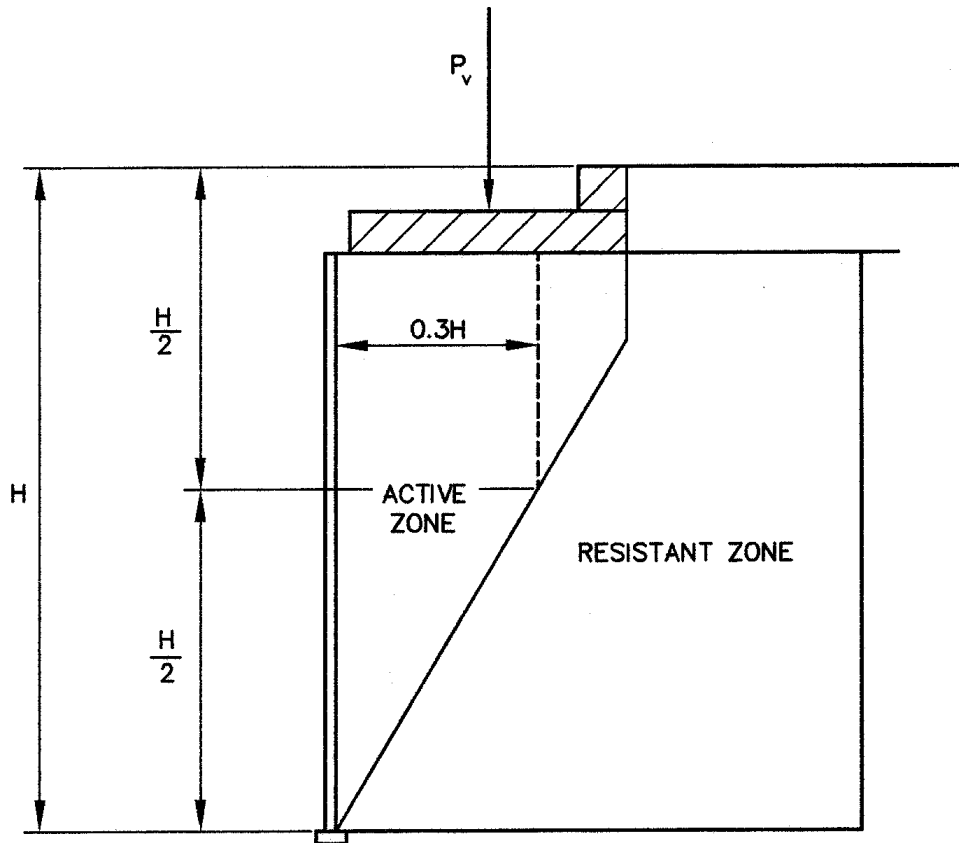

Figure 11.10.10.1-2—Location of Maximum Tensile Force Line in Case of Large Surcharge Slabs (Inextensible Reinforcements)

11.10.10.2—Traffic Loads and Barriers

Traffic loads shall be treated as uniform surcharge loads in accordance with the criteria outlined in Article 3.11.6.2. The live load surcharge pressure shall not be less than 2.0 ft of earth. Parapets and traffic barriers, constructed over or in line with the front face of the wall, shall be designed to resist overturning moments by their own mass. Base slabs shall not have any transverse joints, except construction joints, and adjacent slabs shall be joined by shear dowels. The upper layer(s) of soil reinforcements shall have sufficient tensile capacity to resist a concentrated horizontal load of γP_H where $P_H = 10$ kips distributed over a barrier length of 5.0 ft. This force distribution accounts for the local peak force in the soil reinforcements in the vicinity of the concentrated load. This distributed force would be equal to γP_{H1} where $P_{H1} = 2.0$ kips/ft and is applied as shown in Figure 3.11.6.3-2a. γP_{H1} would be distributed to the reinforcements assuming b_f equal to the width of the base slab. Adequate space shall be provided laterally between the back of the facing panels and the traffic barrier/slab to allow the traffic barrier and slab to resist the impact load in sliding and overturning without directly transmitting load to the top facing units.

For checking pullout safety of the reinforcements, the lateral traffic impact load shall be distributed to the upper

C11.10.10.2

The force distribution for pullout calculations is different than that used for tensile calculations because the entire base slab must move laterally to initiate a pullout failure due to the relatively large deformation required.

soil reinforcement using Figure 3.11.6.3-2a, assuming b_f equal to the width of the base slab. The full-length of reinforcements shall be considered effective in resisting pullout due to the impact load. The upper layer(s) of soil reinforcement shall have sufficient pullout capacity to resist a horizontal load of γP_{HI} where $P_{HI} = 10.0$ kips distributed over a 20.0 ft base slab length.

Due to the transient nature of traffic barrier impact loads, when designing for reinforcement rupture, the geosynthetic reinforcement must be designed to resist the static and transient (impact) components of the load as follows:

Refer to C11.10.7.2 which applies to transient loads, such as impact loads on traffic barriers, as well as earthquake loads.

For the static component, see Eq. 11.10.7.2-3.

For the transient components:

$$\Delta\sigma_H S_v \leq \frac{\phi S_{rt} R_c}{RF_{ID} RF_D} \quad (11.10.10.2-1)$$

where:

- $\Delta\sigma_H$ = traffic barrier impact stress applied over reinforcement tributary area per Article 11.10.10.1 (ksf)
- S_v = vertical spacing of reinforcement (ft)
- S_{rt} = ultimate reinforcement tensile resistance required to resist dynamic load component (kips/ft)
- R_c = reinforcement coverage ratio from Article 11.10.6.4.1 (dim.)
- RF_{ID} = strength reduction factor to account for installation damage to reinforcement from Article 11.10.6.4.3b (dim.)
- RF_D = strength reduction factor to prevent rupture of reinforcement due to chemical and biological degradation from Article 11.10.6.4.3b (dim.)

The reinforcement strength required for the static load component must be added to the reinforcement strength required for the transient load component to determine the required total ultimate strength using Eq. 11.10.7.3-3.

Parapets and traffic barriers shall satisfy crash testing requirements as specified in Section 13. The anchoring slab shall be strong enough to resist the ultimate strength of the standard parapet.

Flexible post and beam barriers, when used, shall be placed at a minimum distance of 3.0 ft from the wall face, driven 5.0 ft below grade, and spaced to miss the reinforcements where possible. If the reinforcements cannot be missed, the wall shall be designed accounting for the presence of an obstruction as described in Article 11.10.10.4. The upper two rows of reinforcement shall be designed for an additional horizontal load γP_{HI} , where $P_{HI} = 300$ lbs. per linear ft of wall, 50 percent of which is distributed to each layer of reinforcement.

11.10.10.3—Hydrostatic Pressures

For structures along rivers and streams, a minimum differential hydrostatic pressure equal to 3.0 ft of water shall be considered for design. This load shall be applied at the high-water level. Effective unit weights shall be used in the calculations for internal and external stability beginning at levels just below the application of the differential hydrostatic pressure.

11.10.10.4—Obstructions in the Reinforced Soil Zone

If the placement of an obstruction in the wall soil reinforcement zone such as a catch basin, grate inlet, signal or sign foundation, guardrail post, or culvert cannot be avoided, the design of the wall near the obstruction shall be modified using one of the following alternatives:

- 1) Assuming reinforcement layers must be partially or fully severed in the location of the obstruction, design the surrounding reinforcement layers to carry the additional load which would have been carried by the severed reinforcements.
- 2) Place a structural frame around the obstruction capable of carrying the load from the reinforcements in front of the obstruction to reinforcements connected to the structural frame behind the obstruction as illustrated in Figure 11.10.10.4-1.
- 3) If the soil reinforcements consist of discrete strips and depending on the size and location of the obstruction, it may be possible to splay the reinforcements around the obstruction.

For Alternative 1, the portion of the wall facing in front of the obstruction shall be made stable against a toppling (overturning) or sliding failure. If this cannot be accomplished, the soil reinforcements between the obstruction and the wall face can be structurally connected to the obstruction such that the wall face does not topple, or the facing elements can be structurally connected to adjacent facing elements to prevent this type of failure.

For the second alternative, the frame and connections shall be designed in accordance with Section 6 for steel frames.

For the third alternative, the splay angle, measured from a line perpendicular to the wall face, shall be small enough that the splaying does not generate moment in the reinforcement or the connection of the reinforcement to the wall face. The tensile resistance of the splayed reinforcement shall be reduced by the cosine of the splay angle.

C11.10.10.3

Situations where the wall is influenced by tide or river fluctuations may require that the wall be designed for rapid drawdown conditions, which could result in differential hydrostatic pressure considerably greater than 3.0 ft, or alternatively rapidly draining backfill material such as shot rock or open graded coarse gravel can be used as backfill. Backfill material meeting the gradation requirements in the *AASHTO LRFD Bridge Construction Specifications* for MSE structure backfill is not considered to be rapid draining.

C11.10.10.4

Field cutting of longitudinal or transverse wires of metal grids, e.g., bar mats, should not be allowed unless one of the alternatives in Article 11.10.10.4 is followed and compensating adjustment is made in the wall design.

Typically, the splay of reinforcements is limited to a maximum of 15 degrees.

Note that it may be feasible to connect the soil reinforcement directly to the obstruction depending on the reinforcement type and the nature of the obstruction.

If the obstruction must penetrate through the face of the wall, the wall facing elements shall be designed to fit around the obstruction such that the facing elements are stable, i.e., point loads should be avoided, and such that wall backfill soil cannot spill through the wall face where it joins the obstruction. To this end, a collar next to the wall face around the obstruction may be needed.

If driven piles or drilled shafts must be placed through the reinforced zone, the recommendations provided in Article 11.10.11 shall be followed.

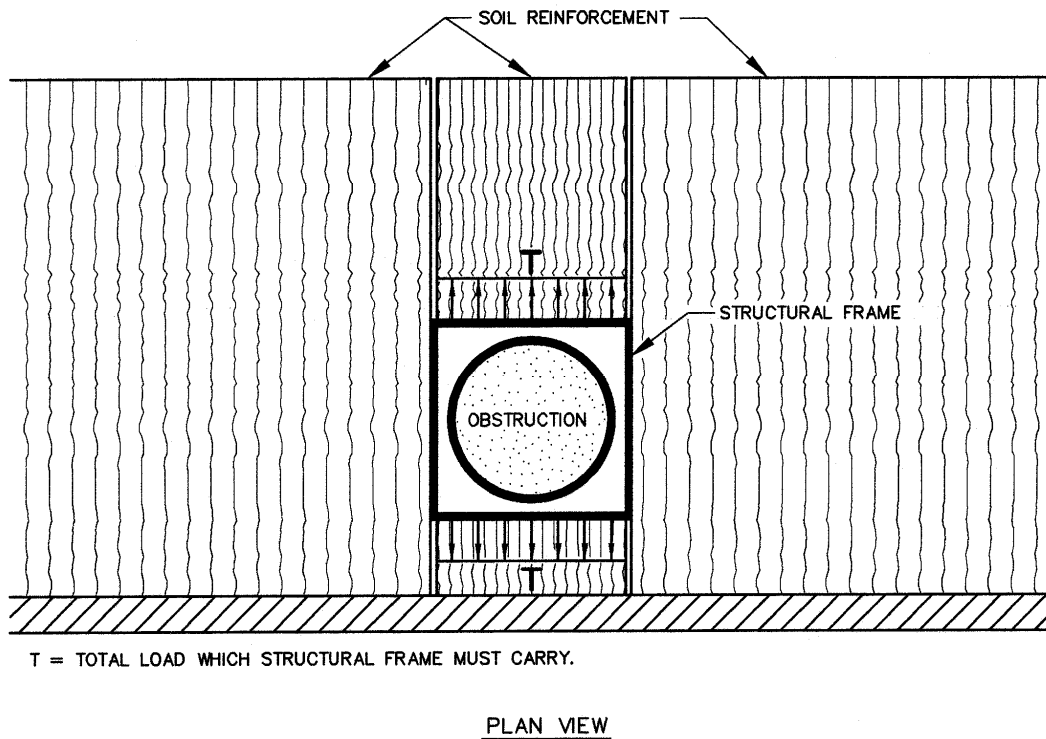

Figure 11.10.10.4-1—Structural Connection of Soil Reinforcement around Backfill Obstructions

11.10.11—MSE Abutments

C11.10.11

Abutments on MSE walls shall be proportioned to meet the criteria specified in Article 11.6.2 through 11.6.6.

The MSE wall below the abutment footing shall be designed for the additional loads imposed by the footing pressure and supplemental earth pressures resulting from horizontal loads applied at the bridge seat and from the backwall. The footing load may be distributed as described in Article 11.10.10.1.

The factored horizontal force acting on the reinforcement at any reinforcement level, T_{max} , shall be taken as:

$$T_{max} = \sigma_{Hmax} S_v \quad (11.10.11-1)$$

where:

σ_{Hmax} = factored horizontal stress at layer i , as defined by Eq. 11.10.11-2 (ksf)

S_v = vertical spacing of reinforcement (ft)

Horizontal stresses in abutment reinforced zones shall be determined by superposition as follows, and as specified in Article 11.10.10.1:

$$\sigma_{Hmax} = \gamma_p (\sigma_v k_r + \Delta\sigma_v k_r + \Delta\sigma_H) \quad (11.10.11-2)$$

where:

- γ_p = load factor for vertical earth pressure in Table 3.4.1-2
- $\Delta\sigma_H$ = magnitude of lateral pressure due to surcharge (ksf)
- σ_v = vertical soil stress over effective base width ($B - 2e$) (ksf)
- $\Delta\sigma_v$ = vertical soil stress due to footing load (ksf)
- k_r = earth pressure coefficient varying as a function of k_a as specified in Article 11.10.6.2.1
- k_a = active earth pressure coefficient specified in Article 3.11.5.8

The effective length used for calculations of internal stability under the abutment footing shall be as described in Article 11.10.10.1 and Figure 11.10.10.1-2.

The minimum distance from the centerline of the bearing on the abutment to the outer edge of the facing shall be 3.5 ft. The minimum distance between the back face of the panel and the footing shall be 6.0 in.

Where significant frost penetration is anticipated, the abutment footing shall be placed on a bed of compacted coarse aggregate 3.0 ft thick as described in Article 11.10.2.2.

The density, length, and cross-section of the soil reinforcements designed for support of the abutment shall be carried on the wingwalls for a minimum horizontal distance equal to 50 percent of the height of the abutment.

In pile or drilled shaft supported abutments, the horizontal forces transmitted to the deep foundation elements shall be resisted by the lateral capacity of the deep foundation elements by provision of additional reinforcements to tie the drilled shaft or pile cap into the soil mass, or by batter piles. Lateral loads transmitted from the deep foundation elements to the reinforced backfill may be determined using a P-Y lateral load analysis technique. The facing shall be isolated from horizontal loads associated with lateral pile or drilled shaft deflections. A minimum clear distance of 1.5 ft shall be provided between the facing and deep foundation elements. Piles or drilled shafts shall be specified to be placed prior to wall construction and cased through the fill if necessary.

The minimum length of reinforcement, based on experience, has been the greater of 22.0 ft or $0.6(H + d) + 6.5$ ft. The length of reinforcement should be constant throughout the height to limit differential settlements across the reinforced zone. Differential settlements could overstress the reinforcements.

The permissible level of differential settlement at abutment structures should preclude damage to superstructure units. This subject is discussed in Article 10.6.2.2. In general, abutments should not be constructed on mechanically stabilized embankments if anticipated differential settlements between abutments or between piers and abutments are greater than one-half the limiting differential settlements described in Article C10.5.2.2.

The equilibrium of the system should be checked at each level of reinforcement below the bridge seat.

Due to the relatively high bearing pressures near the panel connections, the adequacy and ultimate capacity of panel connections should be determined by conducting pullout and flexural tests on full-sized panels.

Moments should be taken at each level under consideration about the centerline of the reinforced mass to determine the eccentricity of load at each level. A uniform vertical stress is then calculated using a fictitious width taken as $(B - 2e)$, and the corresponding horizontal stress should be computed by multiplying by the appropriate coefficient of lateral earth pressure.

11.11—PREFABRICATED MODULAR WALLS

11.11.1—General

Prefabricated modular systems may be considered where conventional gravity, cantilever or counterfort concrete retaining walls are considered.

C11.11.1

Prefabricated modular wall systems, whose elements may be proprietary, generally employ interlocking soil-filled reinforced concrete or steel modules or bins, rock filled gabion baskets, precast concrete units, or dry cast segmental masonry concrete units (without soil reinforcement) which resist earth pressures by acting as gravity retaining walls. Prefabricated modular walls may also use their structural elements to mobilize the dead weight of a portion of the wall backfill through soil arching to provide resistance to lateral loads. Typical prefabricated modular walls are shown in Figure C11.11.1-1.

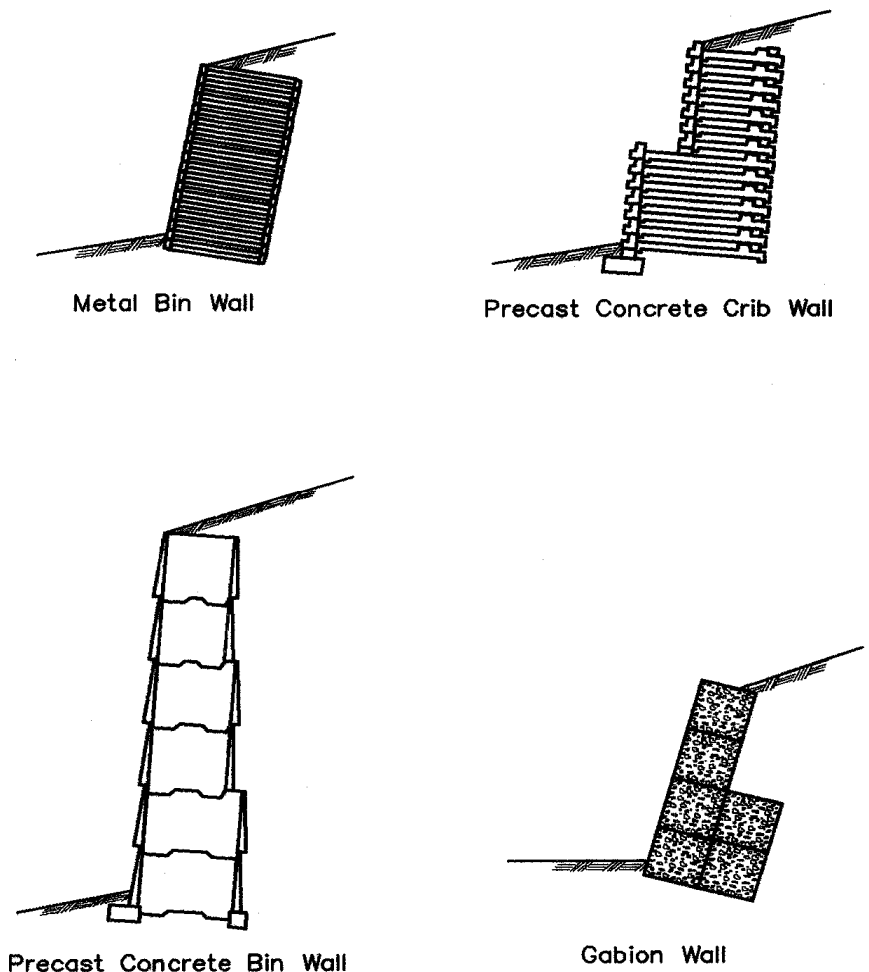

Figure C11.11.1-1—Typical Prefabricated Modular Gravity Walls

Prefabricated modular wall systems shall not be used under the following conditions:

- On curves with a radius of less than 800 ft, unless the curve can be substituted by a series of chords.
- Steel modular systems shall not be used where the groundwater or surface runoff is acid contaminated or where deicing spray is anticipated.

11.11.2—Loading

The provisions of Articles 11.6.1.2 and 3.11.5.9 shall apply, except that shrinkage and temperature effects need not be considered.

11.11.3—Movement at the Service Limit State

The provisions of Article 11.6.2 shall apply as applicable.

11.11.4—Safety against Soil Failure

11.11.4.1—General

For sliding and overturning stability, the system shall be assumed to act as a rigid body. Determination of stability shall be made at every module level.

Passive pressures shall be neglected in stability computations, unless the base of the wall extends below the depth of maximum scour, freeze-thaw, or other disturbance. For these cases only, the embedment below the greater of these depths may be considered effective in providing passive resistance.

11.11.4.2—Sliding

The provisions of Article 10.6.3.4 shall apply.

Computations for sliding stability may consider that the friction between the soil-fill and the foundation soil, and the friction between the bottom modules or footing and the foundation soil are effective in resisting sliding. The coefficient of sliding friction between the soil-fill and foundation soil at the wall base shall be the lesser of ϕ_f of the soil fill and ϕ_f of the foundation soil. The coefficient of sliding friction between the bottom modules or footing and the foundation soil at the wall base shall be reduced, as necessary, to account for any smooth contact areas.

In the absence of specific data, a maximum friction angle of 30 degrees shall be used for ϕ_f for granular soils. Tests should be performed to determine the friction angle of cohesive soils considering both drained and undrained conditions.

11.11.4.3—Bearing Resistance

The provisions of Article 10.6.3 shall apply. Bearing resistance shall be computed by assuming

C11.11.3

Calculated longitudinal differential settlements along the face of the wall should result in a slope less than 1/200.

C11.11.4.3

Concrete modular systems are relatively rigid and are subject to structural damage due to differential

that dead loads and earth pressure loads are resisted by point supports per unit length at the rear and front of the modules or at the location of the bottom legs. A minimum of 80 percent of the soil weight inside the modules shall be considered to be transferred to the front and rear support points. If foundation conditions require a footing under the total area of the module, all of the soil weight inside the modules shall be considered.

11.11.4.4—Overturning

The provisions of Article 11.6.3.3 shall apply.

A maximum of 80 percent of the soil-fill inside the modules is effective in resisting overturning moments.

11.11.4.5 —Subsurface Erosion

Bin walls may be used in scour-sensitive areas only where their suitability has been established. The provisions of Article 11.6.3.5 shall apply.

11.11.4.6—Overall Stability

The provisions of Article 11.6.2.3 shall apply.

11.11.4.7—Passive Resistance and Sliding

The provisions of Articles 10.6.3.4 and 11.6.3.6 shall apply, as applicable.

11.11.5—Safety against Structural Failure

11.11.5.1—Module Members

Prefabricated modular units shall be designed for the factored earth pressures behind the wall and for factored pressures developed inside the modules. Rear face surfaces shall be designed for both the factored earth pressures developed inside the modules during construction and the difference between the factored earth pressures behind and inside the modules after construction. Strength and reinforcement requirements for concrete modules shall be in accordance with Section 5.

Strength requirements for steel modules shall be in accordance with Section 6. The net section used for design shall be reduced in accordance with Article 11.10.6.4.2a.

Factored bin pressures shall be the same for each module and shall not be less than:

$$P_b = \gamma \gamma_s b \quad (11.11.5.1-1)$$

where:

settlements, especially in the longitudinal direction. Therefore, bearing resistance for footing design should be determined as specified in Article 10.6.

C11.11.4.4

The entire volume of soil within the module cannot be counted on to resist overturning, as some soil will not arch within the module. If a structural bottom is provided to retain the soil within the module, no reduction of the soil weight to compute overturning resistance is warranted.

C11.11.5.1

Structural design of module members is based on the difference between pressures developed inside the modules (bin pressures) and those resulting from the thrust of the backfill. The recommended bin pressure relationships are based on relationships obtained for long trench geometry, and are generally conservative.

- P_b = factored pressure inside bin module (ksf)
 γ_s = soil unit weight (kcf)
 γ = load factor for vertical earth pressure specified in Table 3.4.1-2
 b = width of bin module (ft)

Steel reinforcing shall be symmetrical on both faces unless positive identification of each face can be ensured to preclude reversal of units. Corners shall be adequately reinforced.

11.11.6—Seismic Design for Prefabricated Modular Walls

The provisions of Article 11.6.5 shall apply.

C11.11.6

The prefabricated modular wall develops resistance to seismic loads from both the geometry and the weight of the wall section. The primary design issues for seismic loading are global stability, external stability (i.e., sliding, overturning, and bearing), and internal stability. External stability includes the ability of each lift within the wall to also meet external stability requirements. Interlocking between individual structural sections and the soil fill within the wall needs to be considered in this evaluation.

The primary difference for this wall type relative to a gravity or semigravity wall is that sliding and overturning can occur at various heights between the base and top of the wall, as this class of walls typically uses gravity to join sections of the wall together.

The interior of the prefabricated wall elements is normally filled with soil; this provides both additional weight and shear between structural elements. The contributions of the earth, as well as the batter on the wall, need to be considered in the analysis.

Similar to the other external stability checks, the overall (global) stability check needs to consider failure surfaces that pass through the wall section, as well as below the base of the wall. The check on stability at midlevel must consider the contributions of both the soil within the wall and any structural interlocking that occurs for the particular modular wall type.

When checking stability at the mid level of a wall, the additional shear resistance from interlocking of individual wall components will depend on the specific wall type. Usually, interlocking resistance between wall components is provided by the wall supplier.

11.11.7—Abutments

Abutment seats constructed on modular units shall be designed by considering earth pressures and supplemental horizontal pressures from the abutment seat beam and earth pressures on the backwall. The top module shall be proportioned to be stable under the combined actions of normal and supplementary earth pressures. The minimum width of the top module shall be 6.0 ft. The centerline of bearing shall be located a minimum of 2.0 ft from the outside face of the top precast module. The abutment beam seat shall be supported by, and cast integrally with, the top module. The front face thickness of the top module shall be designed for bending forces developed by supplemental earth pressures. Abutment beam-seat loadings shall be carried to foundation level and shall be considered in the design of footings.

Differential settlement provisions, specified in Article 11.10.4, shall apply.

11.11.8—Drainage

In cut and side-hill fill areas, prefabricated modular units shall be designed with a continuous subsurface drain placed at, or near, the footing grade and outletted as required. In cut and side-hill fill areas with established or potential groundwater levels above the footing grade, a continuous drainage blanket shall be provided and connected to the longitudinal drain system.

For systems with open front faces, a surface drainage system shall be provided above the top of the wall.

11.12—REFERENCES

AASHTO. 2010. *AASHTO LRFD Bridge Construction Specifications*, Third Edition, LRFDCONS-3. American Association of State Highway and Transportation Officials, Inc., Washington, DC.

AASHTO. 2010. *Determination of Long-Term Strength of Geosynthetic Reinforcement*, PP 66. American Association of State Highway and Transportation Officials, Inc., Washington, DC. Provisional Standard.

AASHTO. 2011. *AASHTO Guide Specifications for LRFD Seismic Bridge Design*, Second Edition, LRFDSEIS-2. American Association of State and Highway Transportation Officials, Washington, DC.

AASHTO. 2011. *Standard Specifications for Transportation Materials and Methods of Sampling and Testing*, 31st Edition, HM-31. American Association of State and Highway Transportation Officials, Washington, DC.

Al Atik, L. and N. Sitar. 2010. "Seismic Earth Pressures on Cantilever Retaining Structures," *Journal of Geotechnical and Geoenvironmental Engineering*, American Society of Civil Engineers, Reston, VA, October 2010, pp. 1324–1333.

Allen, T. M., and R. J. Bathurst. 2003. *Prediction of Reinforcement Loads in Reinforced Soil Walls*. Report WA-RD 522.2. Washington State Department of Transportation, Olympia, WA.

Allen, T. M., R. J. Bathurst, R. D. Holtz, D. Walters, and W. F. Lee. 2003. "A New Working Stress Method for Prediction of Reinforcement Loads in Geosynthetic Walls," *Canadian Geotechnical Journal*. NRC Research Press, Ottawa, ON, Canada, Vol. 40, pp. 976–994.

Allen, T. M., B. R. Elias, V., and J. D. DiMaggio. 2001. "Development of the Simplified Method for Internal Stability Design of Mechanically Stabilized Earth MSE Walls." WSDOT Research Report WA-RD 513.1, p. 96.

Allen, T. M., A. S. Nowak, and R. J. Bathurst. 2005. *Calibration to Determine Load and Resistance Factors for Geotechnical and Structural Design*, Transportation Research Board Circular E-C079. Transportation Research Board, National Research Council, Washington, DC.

Anderson, D. G., G. R. Martin, I. P. Lam, and J. N. Wang. 2008. *Seismic Analysis and Design of Retaining Walls, Slopes and Embankments, and Buried Structures*, NCHRP Report 611. National Cooperative Highway Research Program, Transportation Research Board, National Research Council, Washington, DC.

API. 1993. *Recommended Practice for Planning, Designing and Constructing Fixed Offshore Platforms—Load and Resistance Factor Design*, First Edition, API Recommended Practice 2A—LRFD (RP 2A-LRFD). American Petroleum Institute, Washington, DC.

ASTM. 2010. *2010 Annual Book of ASTM Standards*. American Society for Testing and Materials, Philadelphia, PA.

Bathurst, R. J. and K. Hatami, K. 1999. Numerical Study on the Influence of Base Shaking on Reinforced-Soil Retaining Walls. In *Proc., Geosynthetics '99*, Boston, MA, pp. 963–976.

Berg, R. R., B. R. Christopher, and N. C. Samtani. 2009. *Design of Mechanically Stabilized Earth Walls and Reinforced Slopes*, Vol. I, No. FHWA-NHI-10-024, and Vol. II, NHI-10-025. Federal Highway Administration, U.S. Department of Transportation, Washington, DC.

Bozozuk, M. 1978. "Bridge Foundations Move." In *Transportation Research Record 678, Tolerable Movements of Bridge Foundations, Sand Drains, K-Test, Slopes, and Culverts*. Transportation Research Board, National Research Council, Washington, DC, pp. 17–21.

Bray, J. D. and T. Travasarou. 2009. "Pseudostatic Coefficient for Use in Simplified Seismic Slope Stability Evaluation," *Journal of Geotechnical and Geoenvironmental Engineering*. American Society of Civil Engineers, Reston, VA, Vol. 135(9), pp. 1336–1340.

Bray, J. D., T. Travasarou, and J. Zupan. 2010. Seismic Displacement Design of Earth Retaining Structures. In *Proc., ASCE Earth Retention Conference 3*, Bellevue, WA. American Society of Civil Engineers, Reston, VA, pp. 638–655.

Caltrans. 2010. *Trenching and Shoring Manual*. Office of Structure Construction, California Department of Transportation, Sacramento, CA.

Cedergren, H. R. 1989. *Seepage, Drainage, and Flow Nets*. 3rd Edition. John Wiley and Sons, Inc., New York, NY, p. 465.

Chen, W. F. and X.L. Liu. 1990. *Limit Analysis in Soil Mechanics*. Elsevier, Maryland Heights, MO.

Cheney, R. S. 1984. *Permanent Ground Anchors*. FHWA-DP-68-1R Demonstration Project. Federal Highway Administration, U.S. Department of Transportation, Washington, DC, p. 132.

Clough, G. W., and T. D. O'Rourke. 1990. "Construction Induced Movement of In-Situ Walls." *Proceedings ASCE Specialty Conference Design and Performance of Earth Retaining Structures*, Cornell University, Ithaca, NY, 1990.

D'Appolonia. 1999. "Developing New AASHTO LRFD Specifications for Retaining Walls." *Final Report for NCHRP Project 20-7, Task 88*. Transportation Research Board, National Research Council, Washington, DC.

Duncan, J. M., and R. B. Seed. 1986. "Compaction Induced Earth Pressures under Ko-Conditions," *ASCE Journal of Geotechnical Engineering*. American Society of Civil Engineers, New York, NY, Vol. 112, No. 1, pp. 1–22.

Duncan, J. M., G. W. Williams, A. L. Sehn, and R. B. Seed. 1991. "Estimation of Earth Pressures Due to Compaction." *ASCE Journal of Geotechnical Engineering*, American Society of Civil Engineers, New York, NY, Vol. 117, No. 12, pp. 1833–1847.

Elias, V., Fishman, K. L., Christopher, B. R., and Berg, R. R. 2009. *Corrosion/Degradation of Soil Reinforcements for Mechanically Stabilized Earth Walls and Reinforced Soil Slopes*, FHWA-NHI-09-087, Federal Highway Administration.

FHWA. 1980. *Technical Advisory T5140.13*. Federal Highways Administration, U.S. Department of Transportation, Washington, DC.

GRI. 1998. "Carboxyl End Group Content of Polyethylene Terephthalate. PET Yarns." *Geosynthetic Research Institute Test Method GG7*.

GRI. 1998. *Determination of the Number Average Molecular Weight of Polyethylene Terephthalate. PET Yarns based on a Relative Viscosity Value*, Test Method GG8. Geosynthetic Research Institute, Philadelphia, PA.

International Standards Organization (ISO). 1999. *Geotextiles and Geotextile-Related Products - Screening Test Method for Determining the Resistance to Oxidation*, ENV ISO 13438:1999. International Standards Organization, Geneva, Switzerland.

Kavazanjian, E., N. Matasovic, T. Hadj-Hamou, and P. J. Sabatini. 1997. "Design Guidance: Geotechnical Earthquake Engineering for Highways," *Geotechnical Engineering Circular* No. 3, Vol. 1—Design Principles, FHWA-SA-97-076. Federal Highway Administration, U.S. Department of Transportation, Washington, DC.

Kramer, S. L. 1996. *Geotechnical Earthquake Engineering*. Prentice Hall, Upper Saddle River, NJ.

Lew, M., N. Sitar, and L. Al Atik. 2010a. Seismic Earth Pressures: Fact or Fiction. In *Proc., ASCE Earth Retention Conference 3*, Bellevue, WA. American Society of Civil Engineers, Reston VA, pp. 656–673.

Lew, M., N. Sitar, L. Al Atik, M. Pouranjani, and M. B. Hudson. 2010b. Seismic Earth Pressures on Deep Building Basements. In *Proc., SEAOC 2010 Convention.*, September 22–25, 2010, Indian Wells, CA. Structural Engineers Association of California, Sacramento, CA, pp. 1–12.

Ling, H. I., D. Leschinsky, and E. B. Perry. 1997. "Seismic Design and Performance of Geosynthetic-Reinforced Soil Structures," *Geotechnique*. Thomas Telford, London, UK, Vol. 47, No. 5, pp. 933–952.

Mitchell, J. K. and W. C. B. Villet. 1987. *Reinforcement of Earth Slopes and Embankments*, NCHRP Report 290. Transportation Research Board, National Research Council, Washington, DC.

Moulton, L. K., V. S. Hota, Rao Ganga, and G. T. Halvorsen. 1985. *Tolerable Movement Criteria for Highway Bridges*, FHWA RD-85-107. Federal Highway Administration, U.S. Department of Transportation, Washington, DC, p. 118.

Nakamura, S. 2006. "Reexamination of Mononobe-Okabe Theory of Gravity Retaining Walls Using Centrifuge Model Tests," *Soils and Foundations*. Japanese Geotechnical Society, Tokyo, Japan, Vol. 46, No. 2, pp. 135–146.

Newmark, N. 1965. "Effects of Earthquakes on Dams and Embankments," *Geotechnique*. Thomas Telford, London, UK, Vol. 15, No. 2. pp. 139–160.

Peck, R. B., W. E. Hanson, and T. H. Thornburn. 1974. *Foundation Engineering*, Second Edition. John Wiley & Sons, Hoboken, NJ.

Prakash, S. and S. Saran. 1966. Static and Dynamic Earth Pressure Behind Retaining Walls. In *Proc., Third Symposium on Earthquake Engineering*, Roorkee, India, November 1966. Vol. 1, pp. 273–288.

PTI. 1996. *Recommendations for Prestressed Rock and Soil Anchors*, Third Edition. Post-Tensioning Institute, Phoenix, AZ.

Richards R. and X. Shi. 1994. "Seismic Lateral Pressures in Soils with Cohesion," *Journal of Geotechnical Engineering*. American Society of Civil Engineers, Reston, VA, Vol. 120, No. 7, pp. 1230–1251.

Sabatini, P. J., D. G. Pass, and R. C. Bachus. 1999. "Ground Anchors and Anchored Systems." *Geotechnical Engineering Circular* No. 4, FHWA-SA-99-015. Federal Highway Administration, U.S. Department of Transportation, Washington, DC, p. 281.

Sankey, J. E., and P. L. Anderson. 1999, "Effects of Stray Currents on the Performance of Metallic Reinforcements in Reinforced Earth Structures," *Transportation Research Record 1675*. Transportation Research Board, National Research Council, Washington, DC, pp. 61–66.

Seed, H. B. and R. V. Whitman. 1970. "Design of Earth Retaining Structures for Dynamic Loads." In *Proc., ASCE Specialty Conference on Lateral Stresses in the Ground and Design of Earth Retaining Structures*. American Society of Civil Engineers, NY, pp. 103–147.

Segrestin, P. and M. L. Bastick. 1988. Seismic Design of Reinforced Earth Retaining Walls—The Contribution of Finite Element Analysis. International Geotechnical Symposium on Theory and Practice of Earth Reinforcement, Fukuoka, Japan, October 1988.

Shamsabadi, A., K. M. Rollins, and M. Kapuskar. 2007. "Nonlinear Soil-Abutment-Bridge Structure Interaction for Seismic Performance-Based Design," *Journal of Geotechnical and Geoenvironmental Engineering*, American Society of Civil Engineers, Reston, VA, Vol. 133, No. 6, pp. 707–720.

Simac, M. R., R. J. Bathurst, R. R. Berg, and S. E. Lothspeich. 1993. "Design Manual for Segmental Retaining Walls." *Modular Concrete Block Retaining Wall Systems*, First Edition. National Concrete Masonry Association, Herndon, VA.

Teng, W. C. 1962. *Foundation Design*. Prentice-Hall, Inc., Englewood Cliffs, NJ.

Terzaghi, K., and R. G. Peck. 1967. *Soil Mechanics in Engineering Practice*, Third Edition. John Wiley and Sons, Inc., New York, NY, p. 729.

Vrymoed, J. (1989). "Dynamic Stability of Soil-Reinforced Walls," *Transportation Research Board Record 1242*, pp. 29–45.

Wahls, H. E. 1990. *Design and Construction of Bridge Approaches*, NCHRP Synthesis of Highway Practice 159. Transportation Research Board, National Research Council, Washington, DC, p. 45.

Walkinshaw, J. L. 1978. "Survey of Bridge Movements in the Western United States." In *Transportation Research Record 678, Tolerable Movements of Bridge Foundations, Sand Drains, K-Test, Slopes, and Culverts*. Transportation Research Board, National Research Council, Washington, DC, pp. 6–11.

Washington State Department of Transportation (WSDOT). 2009. "Standard Practice for Determination of Long-Term Strength for Geosynthetic Reinforcement," *WSDOT Materials Manual*, M 46-01.03.

Weatherby, D. E. 1982. *Tiebacks*, FHWA RD-82-047. Federal Highway Administration, U.S. Department of Transportation, Washington, DC, p. 249.

Wood, J. H. 1973. *Earthquake-Induced Soil Pressures on Structures*, Report No. EERL 73-05. Earthquake Engineering Research Lab, California Institute of Technology, Pasadena, CA.

Yannas, S. F. 1985. *Corrosion Susceptibility of Internally Reinforced Soil-Retaining Walls*, FHWA RD-83-105. Federal Highway Administration, U.S. Department of Transportation, Washington, DC.

Yen, W. P., G. Chen, I. G. Buckle, T. M. Allen, D. Alzamora, J. Ger, and J. G. Arias. 2011. *Post-Earthquake Reconnaissance Report on Transportation Infrastructure Impact of the February 27, 2010 Offshore Maule Earthquake in Chile*, FHWA Report No. FHWA-HRT-11-030. Federal Highways Administration, U.S. Department of Transportation, Washington, DC.

APPENDIX A11—SEISMIC DESIGN OF RETAINING STRUCTURES

A11.1—GENERAL

This Appendix provides information that supplements the provisions contained in Section 11 regarding the design walls and free standing abutments for seismic loads. Detailed design methodology is provided for the calculation of seismic earth pressures, both active and passive. Design methodology is also provided for the estimation of deformation effects on the seismic acceleration a wall will experience.

A11.2—PERFORMANCE OF WALLS IN PAST EARTHQUAKES

Even as early as 1970, Seed and Whitman (1970) concluded that “many walls adequately designed for static earth pressures will automatically have the capacity to withstand earthquake ground motions of substantial magnitudes and, in many cases, special seismic provisions may not be needed.” Seed and Whitman further indicated that this statement applies to gravity and semigravity walls with peak ground accelerations up to 0.25g. More recently, Bray et al. (2010) and Lew et al. (2010a, 2010b) indicate that lateral earth pressure increases due to seismic ground motion are likely insignificant for peak ground accelerations of 0.3g to 0.4g or less, indicating that walls designed to resist static loads (i.e., the strength and service limit states) will likely have adequate stability for the seismic loading case, especially considering that load and resistance factors used for Extreme Event I limit state design are at or near 1.0.

Following the 1971 San Fernando earthquake, Clough and Fragaszy (1977) assessed damage to floodway structures, consisting of reinforced concrete cantilever (vertical) walls structurally tied to a floor slab forming a continuous U-shaped structure. They found that no damage was observed where peak ground accelerations along the structures were less than 0.5g. However, damage and wall collapse was observed where accelerations were higher than 0.5g or localized damage where the structures crossed the earthquake fault and the damage was quite localized. They noted that while higher strength steel rebar was used in the actual structure than required by the static design, the structure was not explicitly designed to resist seismic loads. Gazetas et al. (2004) observed that cantilever semigravity walls with little or no soil surcharge exposed to shaking in the 1999 Athens earthquake performed well for peak ground accelerations up to just under 0.5g even though the walls were not specifically designed to handle seismic loads. Lew et al. (1995) made similar observations with regard to tied back shoring walls in the 1994 Northridge Earthquake and Tatsuoka (1996) similarly observed good wall performance for MSE type gravity walls in the 1995 Kobe earthquake. See Bray et al. (2010), Lew et al. (2010a, 2010b), and Al Atik and Sitar (2010) for additional background on observed wall performance and the generation of seismic earth pressures.

Walls meeting the requirements in Article 11.5.4.2 that allow a seismic analysis to not be conducted have demonstrated consistently good performance in past earthquakes. For wall performance in specific earthquakes, see the following:

- Gravity and semigravity cantilever walls in the 1971 San Fernando Earthquake (Clough and Fragaszy, 1977).
- Gravity and semigravity cantilever walls in the 1999 Athens Earthquake (Gazetas et al., 2004).
- Soil nail walls and MSE walls in the 1989 Loma Prieta, California earthquake (Vucetic et al., 1998 and Collin et al., 1992, respectively).
- MSE walls in the 1994 Northridge, California earthquake (Bathurst and Cai, 1995).
- MSE walls and reinforced concrete gravity walls in the 1995 Kobe, Japan earthquake (Tatsuoka et al., 1996).
- MSE walls and concrete gravity and semigravity walls in the 2010 Maule, Chile earthquake (Yen et al., 2011).
- Summary of the performance of various types of walls (Koseki et al., 2006).
- Reinforced earth walls withstand Northridge Earthquake (Frankenberger et al., 1996).
- The Performance of Reinforced Earth Structures in the Vicinity of Kobe during the Great Hanshin Earthquake (Kobayashi et al, 1996).
- Evaluation of Seismic Performance in Mechanically Stabilized Earth Structures (Sankey et al., 2001).

However, there have been some notable wall failures in past earthquakes. For example, Seed and Whitman (1970) indicated that some concrete gravity walls and quay walls (both gravity structures and anchored sheet pile nongravity cantilever walls), in the great Chilean Earthquake of 1960 and in the Niigata, Japan Earthquake of 1964, suffered severe displacements or even complete collapse. In most of those cases, significant liquefaction behind or beneath the

wall was the likely cause of the failure. Hence, Article 11.5.4.2 specifies that a seismic analysis should be performed if liquefaction or severe strength loss in sensitive clays can cause instability of the wall. Seed and Whitman (1970) indicate, however, that collapse of walls located above the water table has been an infrequent occurrence.

Tatsuoka et al. (1996) indicated that several of the very old (1920s to 1960s) unreinforced masonry gravity walls and concrete gravity structures exposed to strong shaking in the 1995 Kobe Japan earthquake did collapse. In those cases, collapse was likely due to the presence of weak foundation soils that had inadequate bearing and sliding resistance and, in a few cases, due to the presence of a very steep sloping surcharge (e.g., 1.5H:1V) combined with poor soil conditions. Soil liquefaction may have been a contributing factor in some of those cases. These wall collapses were mostly located in the most severely shaken areas (e.g., as high as 0.6g to 0.8g). As noted previously, Clough and Frigaszy (1977) observed concrete cantilever walls supporting open channel floodways that had collapsed where peak ground accelerations were 0.5g or more in the 1971 San Fernando earthquake. However, in that case, soil conditions were good. All of these wall cases where collapse or severe damage/deformations occurred are well outside of the conditions and situations where Article 11.5.4.2 allows the seismic design of walls to be waived.

Setting the limit at 0.4g for the Article 11.5.4.2 no seismic analysis provision represents a reasonable compromise between observations from laboratory modeling and full-scale wall situations (i.e., lab modeling indicates that seismic earth pressures are very low, below 0.4g, and walls in actual earthquakes start to have serious problems, including collapses even in relatively good soils, when the acceleration is greater than 0.5g and the wall has not been designed for the full seismic loading). However, if soil strength loss and flow due liquefaction or strength loss in sensitive silts and clays occurs, wall collapse can occur at lower acceleration values. Note that for the lab model studies, the 0.4g limit represents the limit at which significant seismic earth pressure does not appear to develop. However, for walls with a significant structural mass, the inertial force on the wall mass itself can still occur at accelerations less than 0.4g. At 0.4g, the combination of seismic earth pressure and wall inertial force is likely small enough still to not control the forces in the wall and its stability, provided the wall mass is not large. For typical gravity walls, the wall mass would not be large enough to offset the lack of seismically increased earth pressure below 0.4g. A possible exception regarding wall mass inertial forces is reinforced soil walls, though that inertial mass consists of soil within the reinforced soil zone. However, due to their flexibility, reinforced soil walls perform better than reinforced concrete walls, so the inertial mass issue may not be as important for that type of wall. Note that experience with walls in actual earthquakes in which the walls have not been designed for seismic loads is limited. So while all indications are that major wall problems do not happen until the acceleration is greater than A_s of 0.5g, the majority of those walls where such observations could be made have been strengthened to resist some degree of seismic loading. If walls are not designed for seismic loads, it is reasonable to back off a bit from the observed 0.5g threshold. Hence, 0.4g represents a reasonable buffer relative to potential severe wall damage or collapse as observed for walls in earthquakes at 0.5g or more.

Based on previous experience, walls that form tunnel portals have tended to exhibit more damage due to earthquakes than free-standing walls. It is likely that the presence of the tunnel restricts the ability of the portal wall to move, increasing the seismic forces to which the wall is subjected. Hence, a seismic design is recommended in such cases.

A11.3—CALCULATION OF SEISMIC ACTIVE PRESSURE

Seismic active earth pressures have historically been estimated using the Mononobe-Okabe Method. However, this method is not applicable in some situations. More recently, Anderson et al. (2008) have suggested a generalized limit equilibrium method (GLE) that is more broadly applicable. Both methods are provided herein. Specifications which should be used to select which method to use are provided in Article 11.6.5.3.

A11.3.1—Mononobe-Okabe Method

The method most frequently used for the calculation of the seismic soil forces acting on a bridge abutment or free-standing wall is a pseudostatic approach developed in the 1920s by Mononobe (1929) and Okabe (1926). The Mononobe-Okabe analysis is an extension of the Coulomb sliding-wedge theory, taking into account horizontal and vertical inertia forces acting on the soil. The analysis is described in detail by Seed and Whitman (1970) and Richards and Elms (1979). The following assumptions are made:

1. The abutment is free to yield sufficiently to enable full soil strength or active pressure conditions to be mobilized. If the abutment is rigidly fixed and unable to move, the soil forces will be much higher than those predicted by the Mononobe-Okabe analysis.
2. The backfill is cohesionless, with a friction angle of ϕ .

3. The backfill is unsaturated, so that liquefaction problems will not arise.

The M-O Method is illustrated in Figure A11.3.1-1 and the equation used to calculate K_{AE} follows the figure.

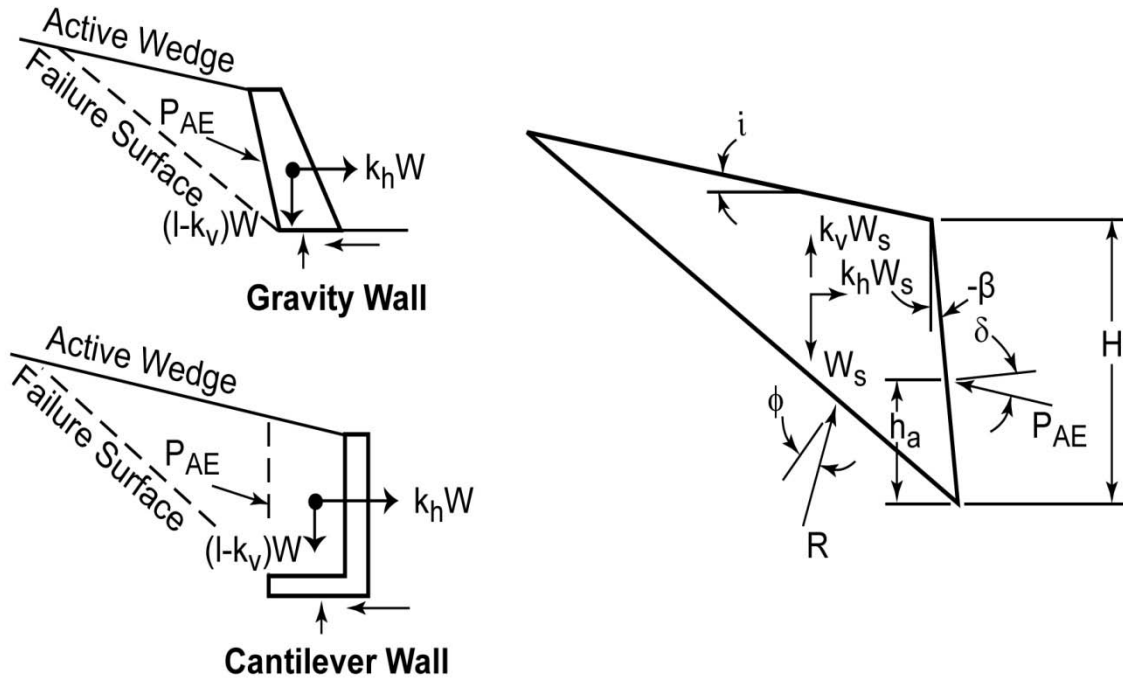

Figure A11.3.1-1—Mononobe-Okabe Method Force Diagrams

$$K_{AE} = \frac{\cos^2(\phi - \theta_{MO} - B)}{\cos \theta_{MO} \cos^2 \beta \cos(\delta + \beta + \theta_{MO})} \times \left[1 - \sqrt{\frac{\sin(\phi + \delta) \sin(\phi - \theta_{MO} - i)}{\cos(\delta + \beta + \theta_{MO}) \cos(i - \beta)}} \right]^{-2} \quad (\text{A11.3.1-1})$$

where:

- K_{AE} = seismic active earth pressure coefficient (dim)
- γ = unit weight of soil (kef)
- H = height of wall (ft)
- h = height of wall at back of wall heel considering height of sloping surcharge, if present (ft)
- ϕ_f = friction angle of soil (degrees)
- θ_{MO} = arc tan $[k_h/(1 - k_v)]$ (degrees)
- δ = wall backfill interface friction angle (degrees)
- k_h = horizontal seismic acceleration coefficient (dim.)
- k_v = vertical seismic acceleration coefficient (dim.)
- i = backfill slope angle (degrees)
- β = slope of wall to the vertical, negative as shown (degrees)

In discussion of the M-O method to follow, H and h should be considered interchangeable, depending on the type of wall under consideration (see Figure A11.3.1-1).

Mononobe and Matsuo (1932) originally suggested that the resultant of the active earth pressure during seismic loading remain the same as for when only static forces are present (i.e., $H/3$ or $h/3$). However, theoretical considerations by Wood (1973), who found that the resultant of the dynamic pressure acted approximately at midheight and empirical considerations from model studies summarized by Seed and Whitman (1970) who suggested that h_a could be obtained by assuming that the static component of the soil force acts at $H/3$ from the bottom of the wall and the additional dynamic effect acts at a height of $0.6H$, resulted in increasing the height of the resultant location above the wall base. Therefore, in past practice, designers have typically assumed that $h_a = H/2$ with a uniformly distributed pressure. Note that if the wall has a protruding heel or if the wall is an MSE wall then replace H with h in the preceding discussion.

Back analysis of full-scale walls in earthquakes, however, indicates earth pressure resultants located higher than $h/3$ will overestimate the force, resulting in a prediction of wall failure when in reality the wall performed well (Clough and Frigaszy, 1977). Recent research indicates the location of the resultant of the total earth pressure (static plus seismic) should be located one-third up from the wall based on centrifuge model tests on gravity walls (Al Atik and Sitar, 2010; Bray et al., 2010; and Lew et al., 2010). However, recent work by others (Nakamura, 2006) also indicates that the resultant location could be slightly higher, depending on the specifics of the ground motion and the wall details.

A reasonable approach is to assume that for routine walls, the combined static/seismic resultant should be located at the same location as static earth pressure resultant but no less than $h/3$. Because there is limited evidence that in some cases the combined static/seismic resultant location could be slightly higher than the static earth pressure resultant, a slightly higher resultant location (e.g., $0.4h$ to $0.5h$) for seismic design of walls for which the impact of wall failure is relatively high should be considered. However, for routine wall designs, a combined static/seismic resultant location equal to that used for static design (e.g., $h/3$) is sufficient.

The effects of abutment inertia are not taken into account in the Mononobe-Okabe analysis. Many current procedures assume that the inertia forces due to the mass of the abutment itself may be neglected in considering seismic behavior and seismic design. This is not a conservative assumption, and for those abutments relying on their mass for stability, it is also an unreasonable assumption in that to neglect the mass is to neglect a major aspect of their behavior. The effects of wall inertia are discussed further by Richards and Elms (1979), who show that wall inertia forces should not be neglected in the design of gravity-retaining walls.

A11.3.2—Modification of Mononobe-Okabe Method to Consider Cohesion

The M-O equation for seismic active earth pressure determination has many limitations, as discussed in Anderson et al. (2008). These limitations include the inability to account for cohesion that occurs in the soil. This limitation has been addressed by rederiving the seismic active earth pressure using a Coulomb-type wedge analysis. Generally, soils with more than 15 percent fines content can be assumed to be undrained during seismic loading. For this loading condition, total stress soil parameters, γ and c , should be used.

Eq. A11.3.2-1 that is provided by Anderson et al. (2008), and Figure A11.3.2-1 shows the terms in the equation. This equation is very simple and practical for the design of the retaining walls and the equation has been calibrated with slope stability computer programs.

$$P_{AE} = \frac{W[(1-k_v)\tan(\alpha-\phi)+k_h]-CL[\sin\alpha\tan(\alpha-\phi)+\cos\alpha]-C_A H[\tan(\alpha-\phi)\cos\omega+\sin\omega]}{[1 + \tan(\delta+\omega)\tan(\alpha-\phi)]*\cos(\delta+\omega)} \quad \text{A11.3.2-1}$$

The only variables in Eq. A11.3.2-1 are the failure plane angle α and the trial wedge surface length L . Values of friction angle (ϕ), seismic horizontal coefficient (k_h), seismic vertical coefficient (k_v), soil cohesion (C), soil wall adhesion (C_a), soil wall friction (δ), and soil wall angle (ω) are defined by the designer on the basis of the site conditions and the U.S. Geological Survey seismic hazard maps shown in Section 3.

The recommended approach in this Section is to assume that $k_v = 0$, and $k_h =$ the PGA adjusted for site effects (i.e., A_s , k_{h0} , or k_h , or some combination thereof, if the wall is greater than 20.0 ft in height and horizontal wall displacement can occur and is acceptable). A 50 percent reduction in the resulting seismic coefficient is used when defining k_h if 1.0 to 2.0 in. of permanent ground deformation is permitted during the design seismic event. Otherwise, the peak ground acceleration coefficient should be used. Eq. A11.3.2-1 can be easily calculated in a spreadsheet. Using a simple spreadsheet, the user can search for the angle α and calculate maximum value of P_{AE} .

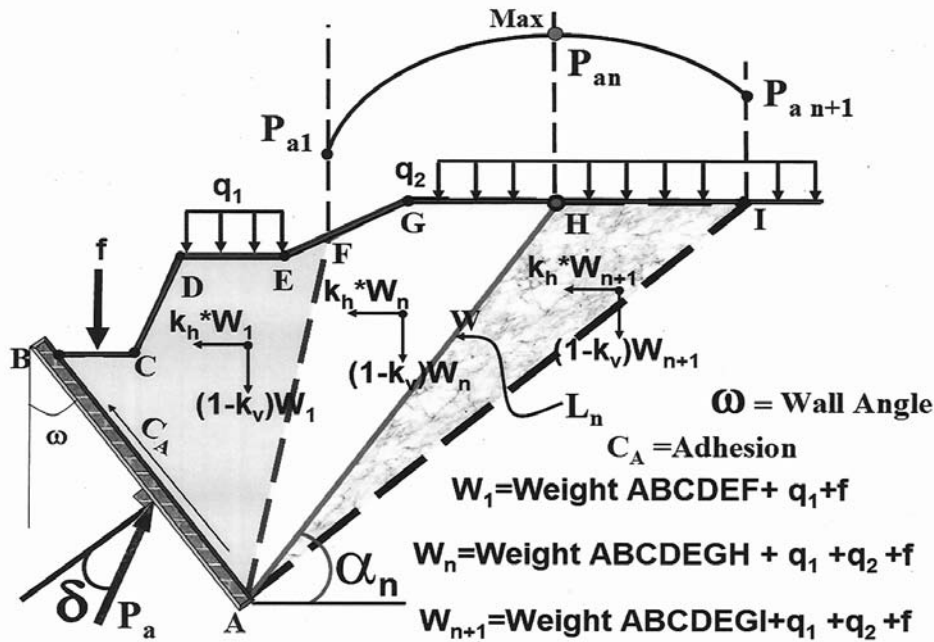

Figure A11.3.2-1—Active Seismic Wedge

The following charts were developed using Eq. A11.3.2-1. These charts are based on level ground behind the wall and a wall friction (δ) of 0.67ϕ . Generally, for active pressure determination, the wall interface friction has a minor effect on the seismic pressure coefficient. However, Eq. A11.3.2-1, the generalized limit equilibrium method, or the charts can be rederived for the specific interface wall friction if this effect is of concern or interest.

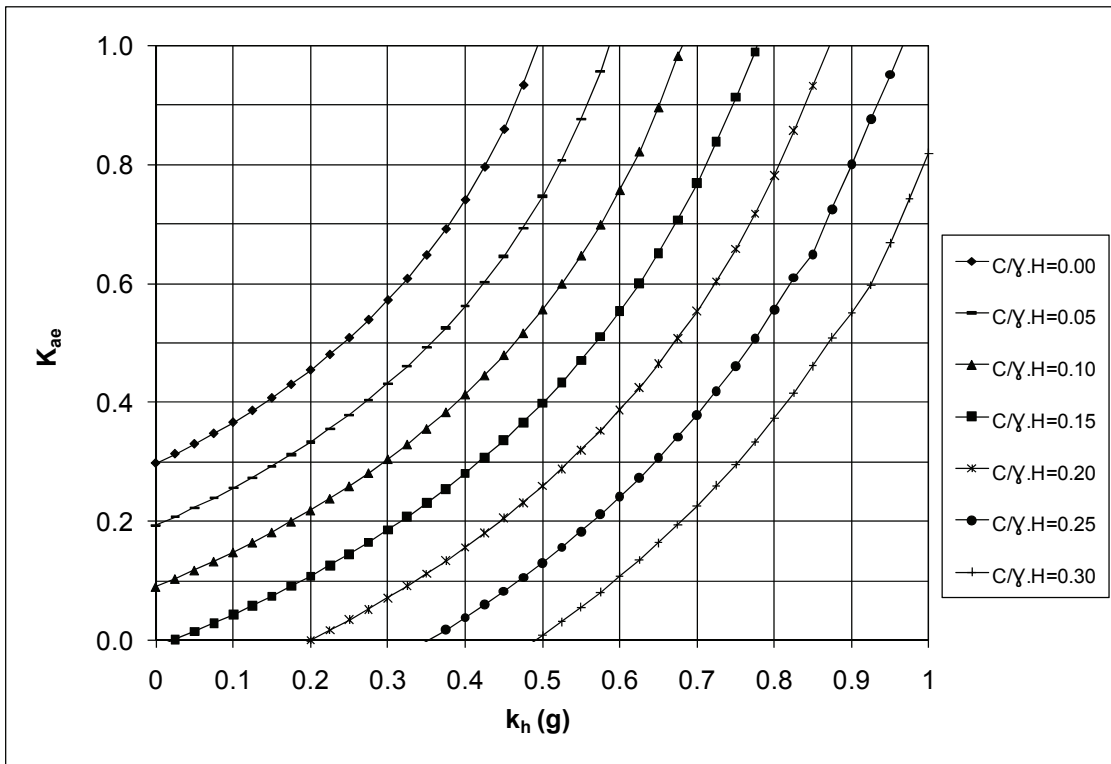

Figure A11.3.2-2—Seismic Active Earth Pressure Coefficient for $\phi = 30$ degrees (c = soil cohesion, γ = soil unit weight, and H = retaining wall height)

Note: $k_h = A_s = k_{h0}$ for wall heights greater than 20 ft. This could be H or h as defined in Figure A11.3.1-1.

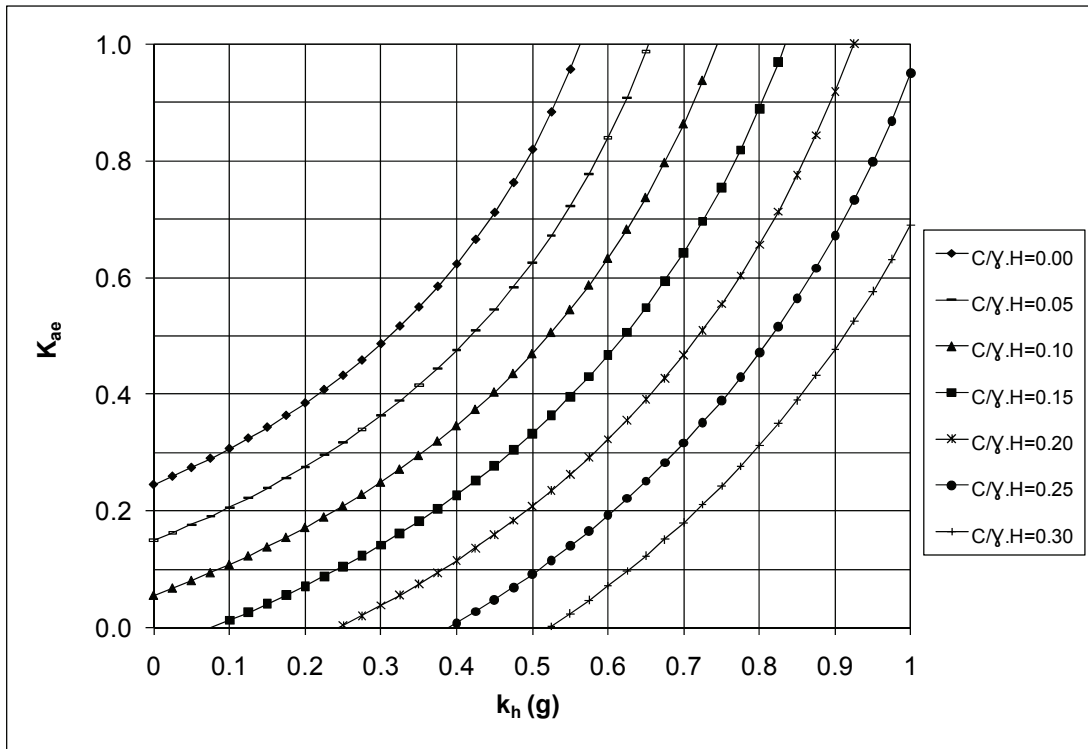

Figure A11.3.2-3—Seismic Active Earth Pressure Coefficient for $\phi = 35$ degrees (c = soil cohesion, γ = soil unit weight, and H = retaining wall height)

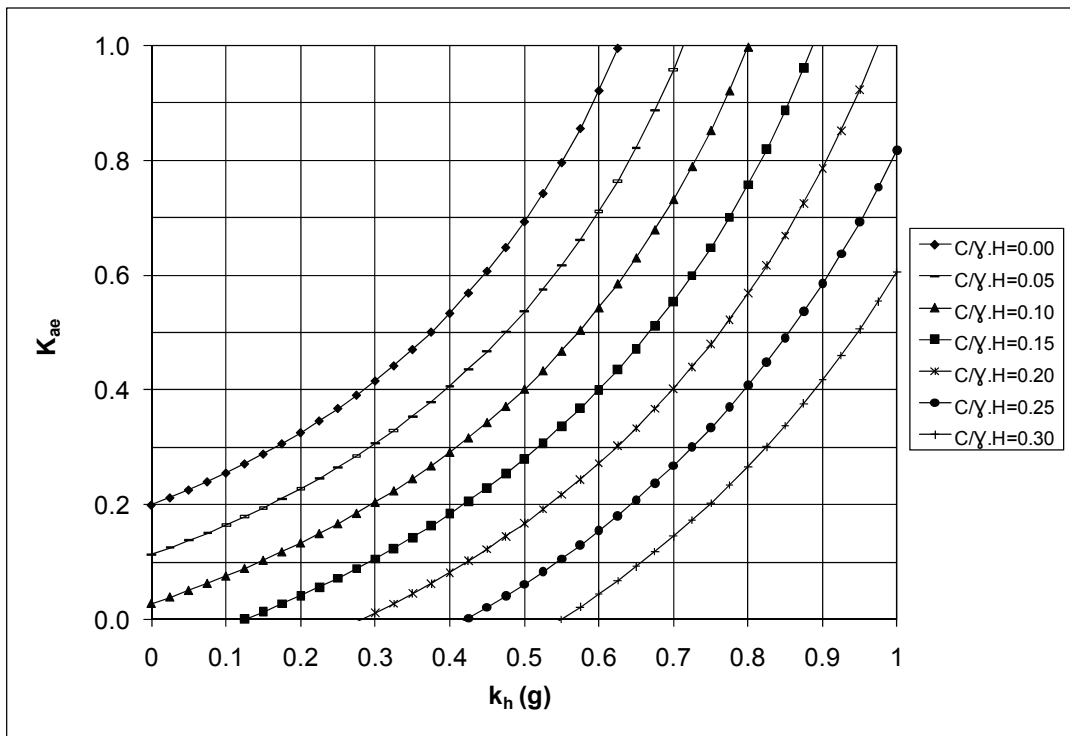

Figure A11.3.2-4—Seismic Active Earth Pressure Coefficient for $\phi = 40$ degrees (c = soil cohesion, γ = soil unit weight, and H = retaining wall height)

A11.3.3—Generalized Limit Equilibrium (GLE) Method

In some situations, the M-O equation is not suitable due to the geometry of the backfill, the angle of the failure surface relative to the cut slope behind the wall, the magnitude of ground shaking, or some combination of these factors (see Article C11.6.5.3). In such situations, a generalized limit equilibrium method involving the use of a computer program for slope stability is likely to be more suitable for determining the earth pressures required for retaining wall design.

Steps in the generalized limit equilibrium (GLE) analysis are as follows:

- Set up the model geometry, groundwater profile, and design soil properties. The internal vertical face at the wall heel or the plane where the earth pressure needs to be calculated should be modeled as a free boundary.
- Choose an appropriate slope stability analysis method. Spencer's method generally yields good results because it satisfies the equilibrium of forces and moments.
- Choose an appropriate sliding surface search scheme. Circular, linear, multi-linear, or random surfaces can be examined in many commercial slope stability analysis programs.
- Apply the earth pressure as a boundary force on the face of the retained soil. For seismic cases, the location of the force may be initially assumed at $1/3H$ of the retained soil. However, different application points between $1/3H$ and $0.6H$ from the base may be examined to determine the maximum seismic earth pressure force. The angle of applied force depends on assumed friction angle between the wall and the fill soil (typically $2/3\phi_f$ for rigid gravity walls) or the fill friction angle (semigravity walls). If static (i.e., nonseismic) forces are also needed, the location of the static force is assumed at one-third from base ($1/3H$, where H is retained soil height).
- Search for the load location and failure surface giving the maximum load for limiting equilibrium (capacity-to-demand ratio of 1.0, i.e., $FS = 1.0$).
- Verify design assumptions and material properties by examining the loads on individual slices in the output as needed.

Additional discussion and guidance regarding this approach is provided in NCHRP Report 611 (Anderson et al., 2008).

A11.4—SEISMIC PASSIVE PRESSURE

This Section provides charts for determination of seismic passive earth pressures coefficients for a soil with both cohesion and friction based on the log spiral method. These charts were developed using a pseudostatic equilibrium method reported in Anderson et al. (2008). The method includes inertial forces within the soil mass, as well as variable soil surface geometries and loads.

Equations used in this approach are given below. Figure A11.4-1 defines the terms used in the equation.

$$dE_i = \frac{W_i(1 - K_v) [\tan(\alpha_i + \phi) - K_h] + C L_i [\sin \alpha_i \tan(\alpha_i + \phi) + \cos \alpha_i]}{[1 - \tan \delta_i \tan(\alpha_i - \phi)] * \cos \delta_i} \quad (\text{A11.4-1})$$

$$P_{pn} = \frac{\sum_1^i dE}{[1 - \tan \delta_w \tan(\alpha_w - \phi)] * \cos \delta_w} \quad (\text{A11.4-2})$$

$$K_{pn} = \frac{2P_p}{\gamma h^2} \quad (\text{A11.4-3})$$

where ϕ is the soil friction angle, c is the cohesion, and δ is wall interface friction.

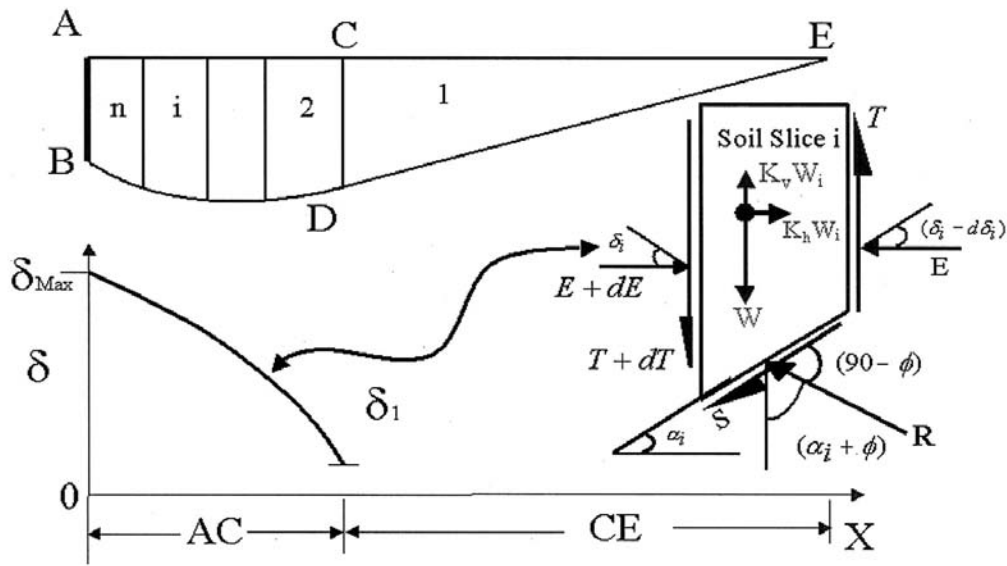

Figure A11.4-1—Limits and Shape Seismic Interslice Force Function (reported in Anderson et al., 2008)

As shown, the method of analysis divides the sliding mass of the backfill into many slices. It is assumed that the shear forces dissipate from a maximum at the wall face (AB) to the induced seismic shear forces at the face (CD) of the first slice as seen in Figure A11.4-1.

The methodology described above was used to develop a series of charts (Figures A11.4-2 through A11.4-4) for a level backfill condition. These charts can be used to estimate the seismic passive pressure coefficient. The interface friction for these charts is 0.67ϕ . These procedures and charts can be used to estimate the seismic passive coefficient for other interface conditions and soil geometries.

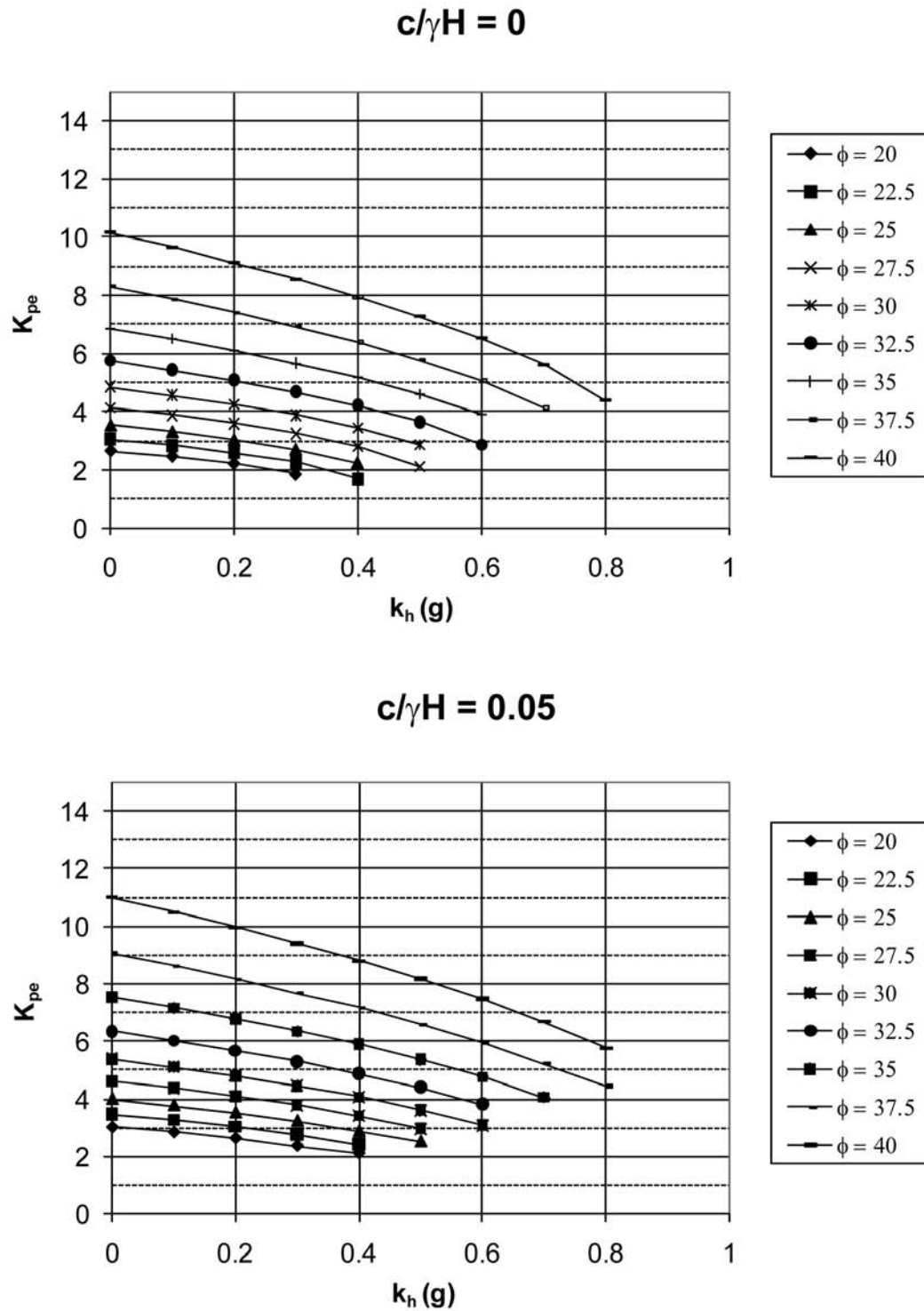

Figure A11.4-2—Seismic Passive Earth Pressure Coefficient Based on Log Spiral Procedure for $c/\gamma H = 0$ and 0.05 (c = soil cohesion, γ = soil unit weight, and H = height or depth of wall over which the passive resistance acts)

Note: $k_h = A_s = k_{ho}$ for wall heights greater than 20 ft.

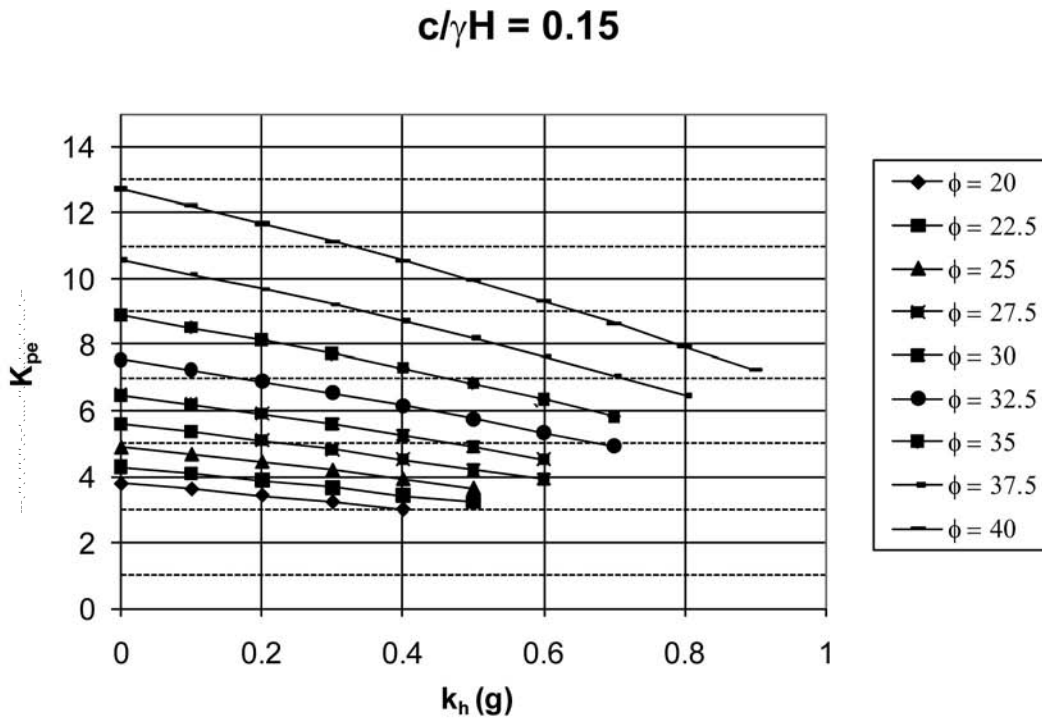
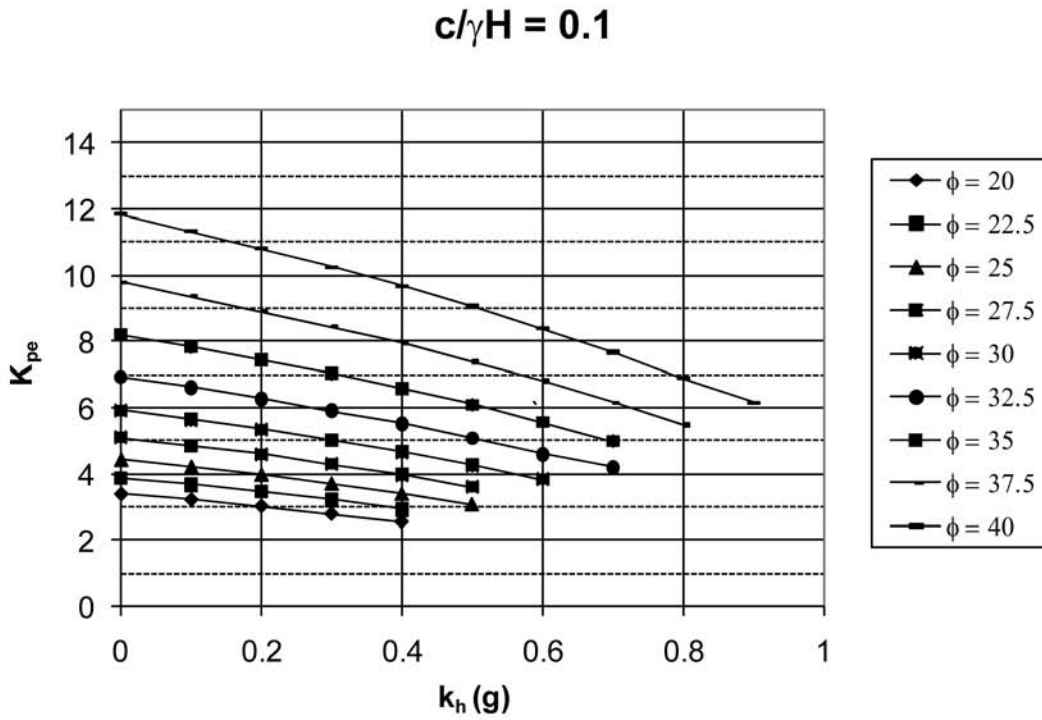

Figure A11.4-3—Seismic Passive Earth Pressure Coefficient Based on Log Spiral Procedure for $c/\gamma H = 0.1$ and 0.15 (c = soil cohesion, γ = soil unit weight, and H = retaining wall height or depth of wall over which the passive resistance acts)

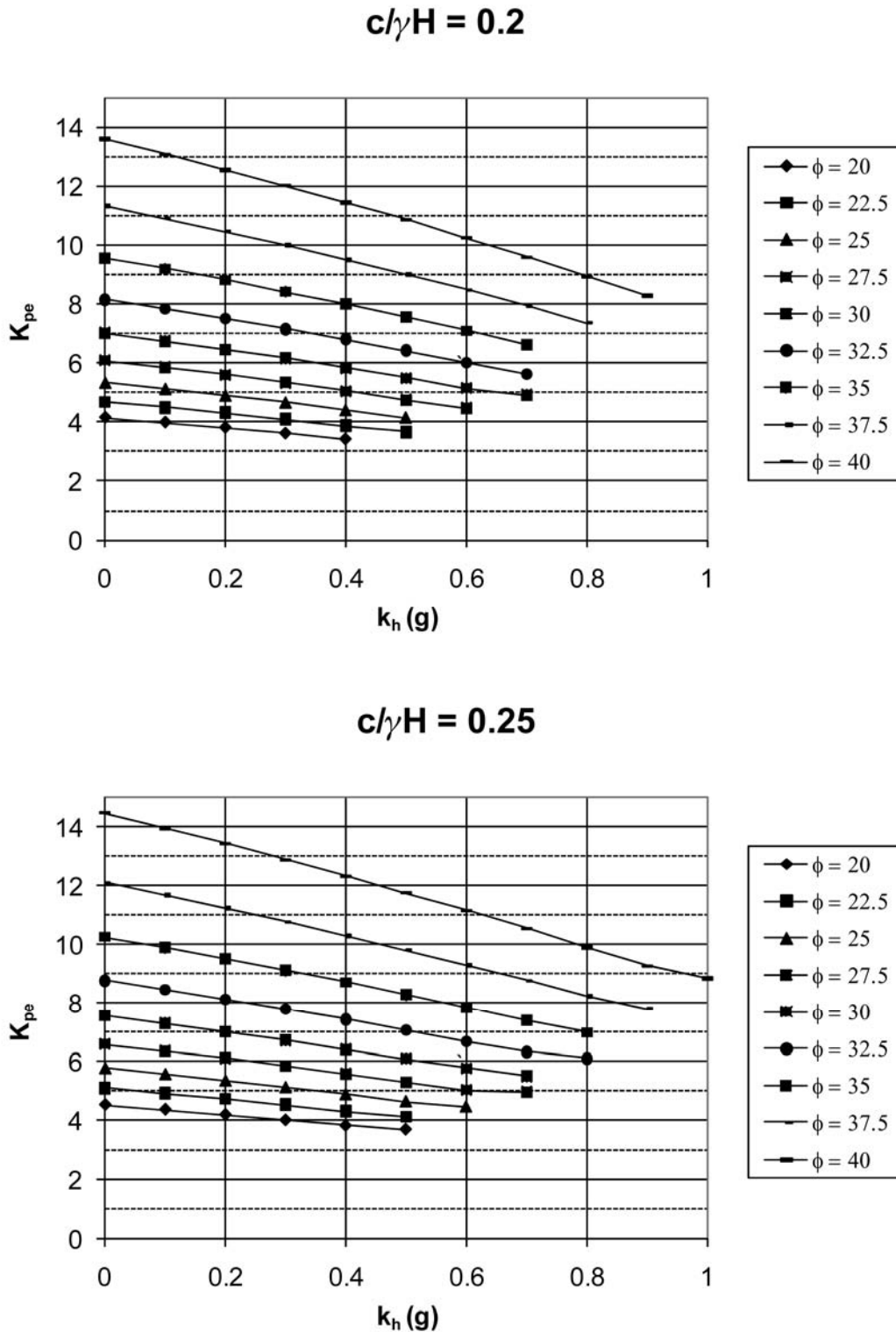

Figure A11.4—Seismic Passive Earth Pressure Coefficient Based on Log Spiral Procedure for $c/\gamma H = 0.2$ and 0.25 (c = soil cohesion, γ = soil unit weight, and H = retaining wall height or depth of wall over which the passive resistance acts)

A11.5—ESTIMATING WALL SEISMIC ACCELERATION CONSIDERING WAVE SCATTERING AND WALL DISPLACEMENT

The seismic acceleration acting on a wall during an earthquake is affected by both wave scattering and wall displacement (see Article 11.6.5.2 and commentary).

With regard to the effects of wall deformation during shaking, the Newmark sliding block concept (Newmark, 1965) was originally developed to evaluate seismic slope stability in terms of earthquake-induced slope displacement as opposed to a factor of safety against yield under peak slope accelerations. The concept is illustrated in Figure A11.5-1, where a double integration procedure on accelerations exceeding the yield acceleration of the slope leads to an accumulated downslope displacement.

The concept of allowing gravity walls to slide during earthquake loading and displacement-based design (i.e., using a Newmark sliding block analysis to compute displacements when accelerations exceed the horizontal limiting equilibrium, yield acceleration for the wall-backfill system) was introduced by Richards and Elms (1979). Based on this concept, Elms and Martin (1979) suggested that a design acceleration coefficient of 0.5 would be adequate for limit equilibrium pseudostatic design, provided allowance be made for a horizontal wall displacement of 10 *PGA* in inches. The *PGA* term in Elms and Martin is equivalent to the F_{PGA} *PGA* or k_{h0} in these Specifications.

For many situations, Newmark analysis or simplifications of it (e.g., displacement design charts or equations based on the Newmark analysis method for certain typical cases, or the use of $k_h = 0.5k_{h0}$) are sufficiently accurate. However, as the complexity of the site or the wall-soil system increases, more rigorous numerical modeling methods may become necessary.

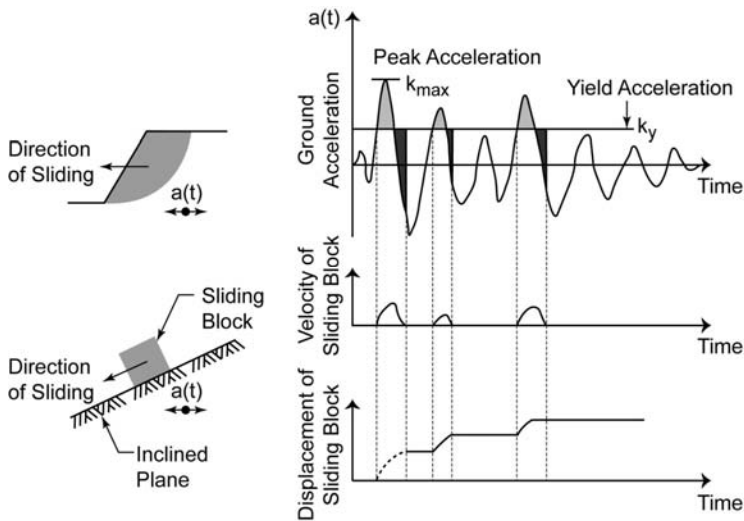

Figure A11.5-1—Newmark Sliding Block Concept

To assess the effects of wave scattering and lateral deformation on the design acceleration coefficient, k_h , three simplified design procedures to estimate the acceleration coefficient are provided in detail in the sub-sections that follow. The first method (Kavazanjian et al., 1997) does not directly address wave scattering and, since wave scattering tends to reduce the acceleration, the first method is likely conservative. The second and third methods account for both wave scattering and wall deformation but are considerably more complex than the first method. With regard to estimation of wave scattering effects, the second method (Anderson et al. 2008) uses a simplified model that considers the effect of the soil mass, but not specifically the effect of the wall as a structure, whereas the third method (Bray et al., 2010) provides a simplified response spectra for the wall, considering the wall to be a structure with a fundamental period. With regard to the effect of lateral wall deformation on the wall acceleration, both methods are based on many Newmark analyses, using those analyses to develop empirical relationships between the yield acceleration for the wall and the soil it retains and the amount of deformation that occurs. The Anderson et al. (2008) method estimates the wall deformation for input yield acceleration, peak ground acceleration, and peak ground velocity, whereas the third method (Bray et al. 2010) estimates the reduced acceleration, k_h , for a specified deformation and spectral acceleration at a specified period. The three alternative design procedures should not be mixed together in any way.

A11.5.1—Kavazanjan et al., (1997)

Kavazanjan et al. (1997) provided the following simplified relationship based on Newmark sliding analysis, assuming that the velocity, in the absence of information on the time history of the ground motion, is equal to $30A$:

$$k_h = 0.74 A_S \left(\frac{A_S}{d} \right)^{0.25} \quad (\text{A11.5.1-1})$$

where:

- A_S = earthquake ground acceleration coefficient as specified in Eq. 3.10.4.2-2 (dim.)
 k_h = horizontal seismic acceleration coefficient (dim.)
 d = lateral wall displacement (in.)

This equation was included in past editions of these Specifications. This equation should not be used for displacements of less than 1.0 in. or greater than approximately 8 in., as this equation is an approximation of a more rigorous Newmark analysis. However, the amount of deformation which is tolerable will depend on the nature of the wall and what it supports, as well as what is in front of the wall. This method may be more conservative than the more complex methods that follow. Note that this method does not address wave scattering within the wall, which in most cases will be conservative.

A11.5.2—NCHRP Report 611—Anderson et al. (2008)

For values of h (as defined in Article 11.6.5.2.2) greater than 20.0 ft but less than 60.0 ft, the seismic coefficient used to compute lateral loads acting on a freestanding retaining wall may be modified to account for the effects of spatially varying ground motions behind the wall, using the following equation:

$$k_h = \alpha k_{h0} \quad (\text{A11.5.2-1})$$

where:

- K_{h0} = αk_{h0}
 α = wall height acceleration reduction factor to account for wave scattering

For Site Class C, D, and E:

$$\alpha = 1 + 0.01h(0.5\beta - 1) \quad (\text{A11.5.2-2})$$

where:

- h = wall height (ft)
 β = $F_v S_1 / k_{h0}$
 S_1 = spectral acceleration coefficient at 1 sec
 F_v = site class adjustment factor

For Site Classes A and B (hard and soft rock foundation soils), note that k_{h0} is increased by a factor of 1.2 as specified in Article 11.6.5.2.1. Eq. A11.5.2-1 provides the value of k_h if only wave scattering is considered and not lateral wall displacement.

For wall heights greater than 60.0 ft, special seismic design studies involving the use of dynamic numerical models should be conducted. These special studies are required in view of the potential consequences of failure of these very tall walls, as well as limitations in the simplified wave scattering methodology.

The basis for the height-dependent reduction factor described above is related to the response of the soil mass behind the retaining wall. Common practice in selecting the seismic coefficient for retaining wall design has been to assume rigid body soil response in the backfill behind a retaining wall. In this approach the horizontal seismic coefficient (k_{h0}) is assumed equal to the $F_{PGA}PGA$ when evaluating lateral forces acting on an active pressure failure zone. Whereas this assumption may be reasonable for wall heights less than about 20.0 ft, for higher walls, the magnitude of accelerations in soils behind the wall will vary spatially as shown schematically in Figure A11.5.2-1.

The nature and variation of the ground motions within a wall is complex and could be influenced by the dynamic response of the wall-soil system to the input earthquake ground motions. In addition to wall height, the acceleration distribution will depend on factors such as the frequency characteristics of the input ground motions, the stiffness contrast between backfill and foundation soils, the overall stiffness and damping characteristics of the wall, and wall slope. From a design standpoint, the net effect of the spatially varying ground motions can be represented by an averaging process over a potential active pressure zone, leading to a time history of average acceleration and hence a maximum average acceleration or seismic coefficient as shown in Figure A11.5.2-1.

To evaluate this averaging process, the results of a series of analytical studies are documented in NCHRP Report 611 (Anderson et al., 2008). An evaluation of these results forms the basis for the simplified Eqs. A11.5.2-1 and A11.5.2-2. The analytical studies included wave scattering analyses assuming elastic soil media using different slope heights, with slopes ranging from near vertical for short walls to significantly battered for tall walls, as well as slopes more typical of embankments (3H:1V) and with a range of earthquake time histories. The properties of the continuum used for these analyses were uniform throughout and therefore did not consider the potential effect of impedance contrasts between different materials (i.e., the properties of the wall vs. that of the surrounding soil). The acceleration time histories simulated spectral shapes representative of Western United States (WUS) and Central and Eastern United States (CEUS) sites and reflected different earthquake magnitudes and site conditions.

Additional height-dependent, one-dimensional SHAKE (Schnaebel et al., 1972) analyses were also conducted to evaluate the influence of nonlinear soil behavior and stiffness contrasts between backfill and foundation soils. These studies were also calibrated against finite element studies for MSE walls documented by Segrestin and Bastick (1988), which form the basis for the average maximum acceleration equation (a function of A_s) given in previous editions of these Specifications. The results of these studies demonstrate that the ratio of the maximum average seismic coefficient (k_h) to A_s (the α factor) is primarily dependent on the wall or slope height and the shape of the acceleration spectra (the β factor). The acceleration level has a lesser effect.

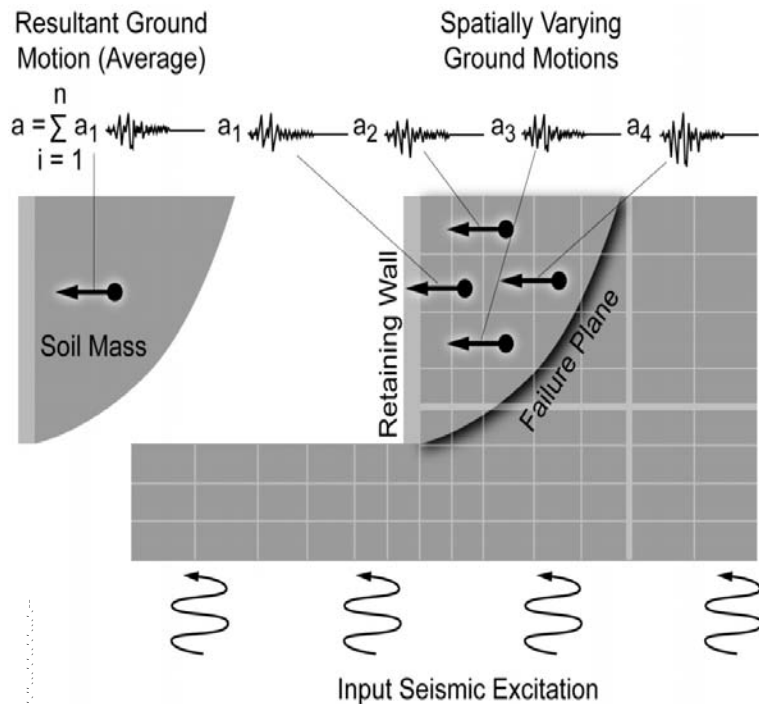

Figure A11.5.2-1—Average Seismic Coefficient Concept

Sliding block displacement analyses were conducted as part of NCHRP Report 611 (Anderson et al., 2008) using an extensive database of earthquake records. The objective of these analyses was to establish updated relationships between wall displacement (d) and the following three terms: the ratio k_y/k_{h0} , k_{h0} as determined in Article 11.6.5.2.1, and PGV . Two broad groups of ground motions were used to develop these equations, CEUS and WUS, as shown in Figure A11.5.2-2 (Anderson et al., 2008). Regressions of those analyses result in the following equations that can be used to estimate the relationship between wall displacement and acceleration.

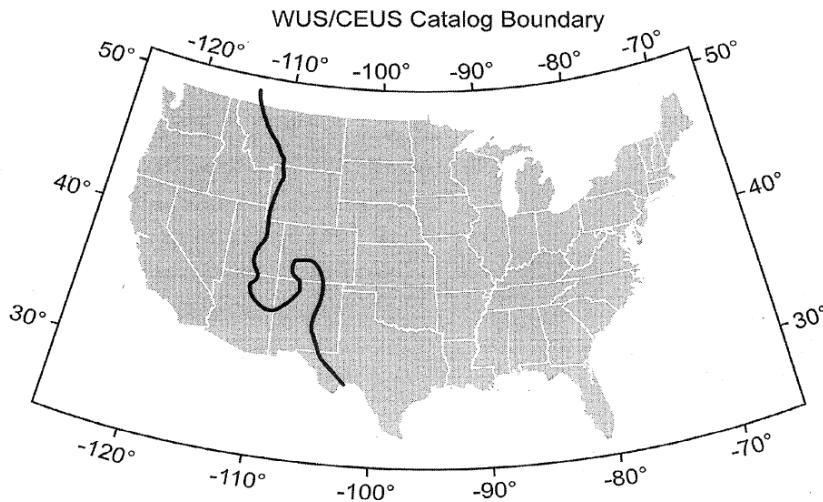

Figure A11.5.2-2—Boundary between WUS and CEUS Ground Motions

For all sites except CEUS rock sites (Categories A and B), the mean displacement (in.) for a given yield acceleration may be estimated as:

$$\log d = -1.51 - 0.74 \log \left(\frac{k_y}{k_{h0}} \right) + 3.27 \log \left(\frac{1 - k_y}{k_{h0}} \right) - 0.80 \log k_{h0} + 1.59 \log (PGV) \quad (\text{A11.5.2-3})$$

where:

k_y = yield acceleration

For CEUS rock sites (Categories A and B), this mean displacement (in.) may be estimated as:

$$\log d = -1.31 - 0.93 \log \left(\frac{k_y}{k_{h0}} \right) + 4.52 \log \left(1 - \frac{k_y}{k_{h0}} \right) - 0.46 \log (k_{h0}) + 1.12 \log (PGV) \quad (\text{A11.5.2-4})$$

Note that the above displacement equations represent mean values.

In Eqs. A11.5.2-3 and A11.5.2-4 it is necessary to estimate the peak ground velocity (PGV) and the yield acceleration (k_y). Values of PGV may be determined using the following correlation between PGV and spectral ordinates at 1 sec (S_1).

$$PGV \text{ (in./sec)} = 38F_v S_1 \quad (\text{A11.5.2-5})$$

where S_1 is the spectral acceleration coefficient at 1 sec and F_v is the site class adjustment factor.

The development of the PGV - S_1 correlation is based on a simplification of regression analyses conducted on an extensive earthquake database established from recorded and synthetic accelerograms representative of both rock and soil conditions for WUS and CEUS. The study is described in NCHRP Report 611 (Anderson et al., 2008). It was found that earthquake magnitude need not be explicitly included in the correlation, as its influence on PGV is captured by its influence on the value of S_1 . The equation is based on the mean from the simplification of the regression analysis.

Values of the yield acceleration (k_y) can be established by computing the seismic coefficient for global stability that results in a capacity to demand (C/D) ratio of 1.0 (i.e., for overall stability of the wall/slope, the $FS = 1.0$). A conventional slope stability program is normally used to determine the yield acceleration. For these analyses, the total stress (undrained) strength parameters of the soil should usually be used in the stability analysis. See guidance on the use of soil cohesion for seismic analyses discussed in Article 11.6.5.3 and its commentary.

Once k_y is determined, the combined effect of wave scattering and lateral wall displacement d on k_h is determined as follows:

$$k_h = \alpha k_y \quad (\text{A11.5.2-6})$$

A11.5.3—Bray et al. (2010), and Bray and Travararou (2009)

The Bray et al. (2010) method (see also Bray and Travararou, 2009) for estimating the value of k_h applied to the wall mass considers both the wave scattering and lateral deformation of the wall. The method was developed using 688 ground motion records. The method characterizes the ground motion using a spectral acceleration at five percent damping, the moment magnitude, M , as a proxy for duration of shaking, the fundamental period of the wall, T_s , and the lateral wall deformation allowed during shaking. In this method, k_h is determined as follows:

$$k_h = \exp\left(\frac{-a + \sqrt{b}}{0.66}\right) \quad (\text{A11.5.3-1})$$

where:

- a = $2.83 - 0.566 \ln(S_a)$
- b = $a^2 - 1.33[\ln(d) + 1.10 - 3.04 \ln(S_a) + 0.244(\ln(S_a))^2 - 1.5T_s - 0.278(M - 7) - \varepsilon]$
- S_a = the five percent damped spectral acceleration coefficient from the site response spectra
- d = the maximum wall displacement allowed, in centimeters
- M = the moment magnitude of the design earthquake
- T_s = the fundamental period of the wall
- ε = a normally distributed random variable with zero mean and a standard deviation of 0.66.

ε should be set equal to zero to estimate k_h considering D_a to be a mean displacement. To calculate the fundamental period of the wall, T_s , use the following equation:

$$T_s = 4H'/V_s \quad (\text{A11.5.3-2})$$

where:

- H' = 80 percent of the height of the wall, as measured from the bottom of the heel of the wall to the ground surface directly above the wall heel (or the total wall height at the back of the reinforced soil zone for MSE walls)
- V_s = the shear wave velocity of the soil behind the wall

Note that V_s and H' must have consistent units. Shear wave velocities may be obtained from in-situ measurements or through the use of correlations to the Standard Penetration Resistance (*SPT*) or cone resistance (q_c). An example of this type of correlation for granular wall backfill materials is shown in Eq. A11.5.3-3 (Imai and Tonouchi, 1982).

$$V_s = 107N^{0.314} \quad (\text{A11.5.3-3})$$

where:

N = the Standard Penetration Resistance (*SPT*) of the fill material, uncorrected for overburden pressure but corrected for hammer efficiency.

The spectral acceleration, S_a , is determined at a degraded period of $1.5T_s$ from the five percent damped response spectra for the site (i.e., either the response spectra determined using the general procedure or using a site-specific response spectra).

To estimate lateral wall displacement for a given acceleration value, see Bray et al. (2010) and Bray and Travararou (2009) for details.

A11.6—APPENDIX REFERENCES

Anderson, D. G., G. R. Martin, I. P. Lam, and J. N. Wang. 2008. *Seismic Analysis and Design of Retaining Walls, Slopes and Embankments, and Buried Structures*, NCHRP Report 611 National Cooperative Highway Research Program, Transportation Research Board, National Research Council, Washington, DC.

Bathurst, R. J. and Z. Cai, Z. 1995. "Pseudo-Static Seismic Analysis of Geosynthetic-Reinforced Segmental Retaining Walls," *Geosynthetics International*. International Geosynthetic Society, Jupiter, FL, Vol. 2, No. 5, pp. 787--830.

Bray, J. D. and T. Travararou. 2009. "Pseudostatic Coefficient for Use in Simplified Seismic Slope Stability Evaluation," *J. of Geotechnical & Geoenvironmental Engineering*. American Society of Civil Engineers, Reston, VA, Vol. 135, No. 9, pp. 1336–1340.

Bray, J. D., T. Travararou, Tand J. Zupan. 2010. Seismic Displacement Design of Earth Retaining Structures. In *Proc., ASCE Earth Retention Conference 3*, Bellevue, WA. American Society of Civil Engineers, Reston, VA, pp. 638–655.

Clough, G. W. and R. F. Fragaszy. 1977. A Study of Earth Loadings on Floodway Retaining Structures in the 1971 San Fernando Valley Earthquake. In *Proc., Sixth World Conference on Earthquake Engineering*, New Delhi, India, January 10–14, 1977, pp. 7-37–7-42. Available in: BSSA. 1978. *Bulletin of the Seismological Society of America*. Seismological Society of America, El Cerrito, CA, Vol. 68, No. 2.

Collin, J. G., V. E. Chouery-Curtis, and R. R. Berg, R. R. 1992. "Field Observation of Reinforced Soil Structures under Seismic Loading," *Earth Reinforcement Practice*, S. Havashi, H. Ochiai, and J. Otani,, eds. Taylor & Francis, Inc., Florence, KY, Vol. 1, pp. 223–228.

Elms, D. A. and G. R. Martin. 1979. Factors Involved in the Seismic Design of Bridge Abutments." In *Proc., Workshop on Seismic Problems Related to Bridges*. Applied Technology Council, Berkeley, CA.

Frankenberger. P. C., R. A. Bloomfield, and P. L. Anderson. 1996. Reinforced Earth Walls Withstand Northridge Earthquake. In *Proc., International Symposium on Earth Reinforcement*, Fukuoka, Kyushu, Japan, November 12–14, 1996. Taylor & Francis, Inc., Florence, KY, pp 345–350.

Gazetas, G., P. N. Psarropoulos, I. Anastasopoulos, and N. Gerolymos. 2004. "Seismic Behavior of Flexible Retaining Systems Subjected to Short-Duration Moderately Strong Excitation," *Soil Dynamics and Earthquake Engineering*. Elsevier, Maryland Heights, MO, Vol. 24, No. 7, pp. 537–550.

Imai, T. and K. Tonouchi. 1982. Correlations of N value with S-wave velocity and shear modulus. In *Proc., Second European Symposium on Penetration Testing*, Amsterdam, The Netherlands, May 24–27, 1982. A. A. Balkema Publishers, London, UK, pp. 24–27.

International Standards Organization (ISO), 1999. *Geotextiles and Geotextile-Related Products—Screening Test Method for Determining the Resistance to Oxidation*, ENV ISO 13438:1999. International Standards Organization, Geneva, Switzerland.

Kobayashi, K. et al. 1996 The Performance of Reinforced Earth Structures in the Vicinity of Kobe during the Great Hanshin Earthquake, In *Proc., International Symposium on Earth Reinforcement*, Fukuoka, Kyushu, Japan, November 12–14, 1996. Taylor & Francis, Inc., Florence, KY, pp. 395–400.

Koseki, J., R. J. Bathurst, E. Guler, J. Kuwano, amd M. Maugeri, M. 2006. Seismic Stability of Reinforced Soil Walls. Invited Keynote Paper, *Eighth International Conference on Geosynthetics*, Yokohama, Japan, September 18–22, 2006. IOS Press, Amsterdam, The Netherlands, pp. 1–28.

Lew, M., E. Simantob, and M. E. Hudson. 1995. Performance of shored earth retaining systems during the January 17, 1994, Northridge Earthquake. In *Proc., Third International Conference on Recent Advances in Geotechnical Earthquake Engineering and Soil Dynamics*, St. Louis, MO, April 2–7. Vol. 3.

Lew, M., N. Sitar, and L. Al Atik. 2010a. Seismic Earth Pressures: Fact or Fiction. In *Proc., ASCE Earth Retention Conference 3*, Bellevue, WA. American Society of Civil Engineers, Reston, VA, pp. 656–673.

Lew, M., N. Sitar, L. Al Atik, M. Pouranjani, and M. B. Hudson. 2010b. Seismic Earth Pressures on Deep Building Basements. In *Proc., SEAOC 2010 Convention*, September 22–25, 2010, Indian Wells, CA. Structural Engineers Association of California, Sacramento, CA, pp. 1–12.

Mononobe, N. 1929. Earthquake-Proof Construction of Masonry Dams. In *Proc., World Engineering Congress*, Tokyo, Japan, October–November 1929. Vol. 9, p. 275.

- Nakamura, S. 2006. "Reexamination of Mononobe-Okabe Theory of Gravity Retaining Walls Using Centrifuge Model Tests," *Soils and Foundations*. Japanese Geotechnical Society, Tokyo, Japan, Vol. 46, No. 2, pp. 135–146.
- Newmark, N. M. 1965. "Effects of Earthquakes on Dams and Embankments," *Geotechnique*. Thomas Telford Ltd., London, UK, Vol. 14, No. 2, pp. 139–160.
- Okabe, S. 1926. "General Theory of Earth Pressure." *Journal of the Japanese Society of Civil Engineers*, Vol. 12, No. 1.
- Richards, R. and D. G. Elms. 1979. "Seismic Behavior of Gravity Retaining Walls." *Journal of the Geotechnical Engineering Division*, American Society of Civil Engineers, New York, NY, Vol. 105, No. GT4, pp. 449–464.
- Sankey, J. E. and P. Segrestin. 2001. "Evaluation of Seismic Performance in Mechanically Stabilized Earth Structures." *Landmarks in Earth Reinforcement: Proceedings of the International Symposium on Earth Reinforcement Practice*, Fukuoka, Kyushu, Japan, Vol. 1, pp. 449–452.
- Seed, H. B. and R. V. Whitman. 1970. Design of Earth Retaining Structures for Dynamic Loads." In *Proc., ASCE Specialty Conference on Lateral Stresses in the Ground and Design of Earth Retaining Structures*. American Society of Civil Engineers, Reston, VA, pp. 103–147.
- Schnabel, P. B., J. Lysmer, and H. B. Seed. 1972. *SHAKE: A Computer Program for Earthquake Response Analysis of Horizontally Layered Sites*, Report No. EERC 72-12. Earthquake Engineering Research Center, University of California, Berkeley, CA.
- Segrestin, P. and M. L. Bastick 1988. Seismic Design of Reinforced Earth Retaining Walls—The Contribution of Finite Element Analysis. In *Proc., International Geotechnical Symposium on Theory and Practice of Earth Reinforcement*, Fukuoka, Japan, October 1988. Thomas Telford Ltd., London, UK.
- Tatsuoka, F., J. Koseki, and M. Tateyama. 1996. Performance of Reinforced Soil Structures during the 1995 Hyogoken Nanbu Earthquake, IS Kyushu '96 Special Report. In *Proc., International Symposium on Earth Reinforcement*, Fukuoka, Kyushu, Japan, November 12–14, 1996, Ochiai et al., eds. Taylor and Francis, Inc., Florence, KY, pp. 1–36.
- Vucetic, M., M. R. Tufenkjian, G. Y. Felio, P. Barar, and K. R. Chapman. 1998. *Analysis of Soil-Nailed Excavations Stability during the 1989 Loma Prieta Earthquake*, Professional Paper 1552-D, T. L. Holzer, ed. U.S. Geological Survey, Washington, DC, pp. 27–46.
- Yen, W. P., G. Chen, I. G. Buckle, T. M. Allen, D. Alzamora, J. Ger, and J. G. Arias. 2011. *Postearthquake Reconnaissance Report on Transportation Infrastructure Impact of the February 27, 2010 Offshore Maule Earthquake in Chile*, FHWA Report No. FHWA-HRT-11-030. Federal Highways Administration, U.S. Department of Transportation, Washington, DC.

SECTION 12: BURIED STRUCTURES AND TUNNEL LINERS

TABLE OF CONTENTS

12.1—SCOPE 12-1

12.2—DEFINITIONS 12-1

12.3—NOTATION 12-1

12.4—SOIL AND MATERIAL PROPERTIES 12-6

 12.4.1—Determination of Soil Properties 12-6

 12.4.1.1—General 12-6

 12.4.1.2—Foundation Soils 12-6

 12.4.1.3—Envelope Backfill Soils 12-6

 12.4.2—Materials 12-7

 12.4.2.1—Aluminum Pipe and Structural Plate Structures 12-7

 12.4.2.2—Concrete 12-7

 12.4.2.3—Precast Concrete Pipe 12-7

 12.4.2.4—Precast Concrete Structures 12-7

 12.4.2.5—Steel Pipe and Structural Plate Structures 12-7

 12.4.2.6—Deep Corrugated Structures 12-8

 12.4.2.7—Steel Reinforcement 12-8

 12.4.2.8—Thermoplastic Pipe 12-8

12.5—LIMIT STATES AND RESISTANCE FACTORS 12-8

 12.5.1—General 12-8

 12.5.2—Service Limit State 12-9

 12.5.3—Strength Limit State 12-9

 12.5.4—Load Modifiers and Load Factors 12-9

 12.5.5—Resistance Factors 12-10

 12.5.6—Flexibility Limits and Construction Stiffness 12-12

 12.5.6.1—Corrugated Metal Pipe and Structural Plate Structures 12-12

 12.5.6.2—Spiral Rib Metal Pipe and Pipe Arches 12-12

 12.5.6.3—Flexibility Limits and Construction Stiffness—Thermoplastic Pipe 12-13

 12.5.6.4—Steel Tunnel Liner Plate 12-13

12.6—GENERAL DESIGN FEATURES 12-13

 12.6.1—Loading 12-13

 12.6.2—Service Limit State 12-14

 12.6.2.1—Tolerable Movement 12-14

 12.6.2.2—Settlement 12-14

 12.6.2.2.1—General 12-14

 12.6.2.2.2—Longitudinal Differential Settlement 12-14

 12.6.2.2.3—Differential Settlement between Structure and Backfill 12-14

 12.6.2.2.4—Footing Settlement 12-14

 12.6.2.2.5—Unbalanced Loading 12-15

 12.6.2.3—Uplift 12-18

 12.6.3—Safety against Soil Failure 12-18

 12.6.3.1—Bearing Resistance and Stability 12-18

12.6.3.2—Corner Backfill for Metal Pipe Arches	12-19
12.6.4—Hydraulic Design	12-19
12.6.5—Scour	12-19
12.6.6—Soil Envelope	12-19
12.6.6.1—Trench Installations	12-19
12.6.6.2—Embankment Installations	12-19
12.6.6.3—Minimum Cover	12-20
12.6.7—Minimum Spacing between Multiple Lines of Pipe	12-21
12.6.8—End Treatment	12-22
12.6.8.1—General	12-22
12.6.8.2—Flexible Culverts Constructed on Skew	12-22
12.6.9—Corrosive and Abrasive Conditions	12-23
12.7—METAL PIPE, PIPE ARCH, AND ARCH STRUCTURES	12-24
12.7.1—General	12-24
12.7.2—Safety against Structural Failure	12-24
12.7.2.1—Section Properties	12-24
12.7.2.2—Thrust	12-24
12.7.2.3—Wall Resistance	12-25
12.7.2.4—Resistance to Buckling	12-25
12.7.2.5—Seam Resistance	12-25
12.7.2.6—Handling and Installation Requirements	12-25
12.7.3—Smooth Lined Pipe	12-26
12.7.4—Stiffening Elements for Structural Plate Structures	12-26
12.7.5—Construction and Installation	12-26
12.8—LONG-SPAN STRUCTURAL PLATE STRUCTURES	12-26
12.8.1—General	12-26
12.8.2—Service Limit State	12-27
12.8.3—Safety against Structural Failure	12-27
12.8.3.1—Section Properties	12-27
12.8.3.1.1—Cross-Section	12-27
12.8.3.1.2—Shape Control	12-28
12.8.3.1.3—Mechanical and Chemical Requirements	12-28
12.8.3.2—Thrust	12-29
12.8.3.3—Wall Area	12-29
12.8.3.4—Seam Strength	12-29
12.8.3.5—Acceptable Special Features	12-29
12.8.3.5.1—Continuous Longitudinal Stiffeners	12-29
12.8.3.5.2—Reinforcing Ribs	12-29
12.8.4—Safety against Structural Failure—Foundation Design	12-29
12.8.4.1—Settlement Limits	12-29
12.8.4.2—Footing Reactions in Arch Structures	12-30
12.8.4.3—Footing Design	12-31
12.8.5—Safety against Structural Failure—Soil Envelope Design	12-31
12.8.5.1—General	12-31
12.8.5.2—Construction Requirements	12-31

12.8.5.3—Service Requirements	12-32
12.8.6—Safety against Structural Failure—End Treatment Design	12-33
12.8.6.1—General.....	12-33
12.8.6.2—Standard Shell End Types.....	12-33
12.8.6.3—Balanced Support.....	12-35
12.8.6.4—Hydraulic Protection.....	12-35
12.8.6.4.1—General	12-35
12.8.6.4.2—Backfill Protection.....	12-36
12.8.6.4.3—Cut-Off (Toe) Walls	12-36
12.8.6.4.4—Hydraulic Uplift.....	12-36
12.8.6.4.5—Scour.....	12-36
12.8.7—Concrete Relieving Slabs.....	12-36
12.8.8—Construction and Installation	12-37
12.8.9—Deep Corrugated Structural Plate Structures	12-37
12.8.9.1—General.....	12-37
12.8.9.2—Width of Structural Backfill	12-37
12.8.9.2.1—Deep Corrugated Structures with Ratio of Crown Radius to Haunch Radius ≤ 5	12-37
12.8.9.2.2—Deep Corrugated Structures with Ratio of Crown Radius to Haunch Radius > 5	12-37
12.8.9.3—Safety against Structural Failure.....	12-38
12.8.9.3.1—Structural Plate Requirements	12-38
12.8.9.3.2—Structural Analysis	12-38
12.8.9.4—Minimum Depth of Fill.....	12-38
12.8.9.5—Combined Thrust and Moment.....	12-39
12.8.9.6—Global Buckling.....	12-40
12.8.9.7—Connections	12-40
12.9—STRUCTURAL PLATE BOX STRUCTURES	12-40
12.9.1—General.....	12-40
12.9.2—Loading.....	12-41
12.9.3—Service Limit State.....	12-41
12.9.4—Safety against Structural Failure.....	12-41
12.9.4.1—General.....	12-41
12.9.4.2—Moments Due to Factored Loads.....	12-42
12.9.4.3—Plastic Moment Resistance	12-44
12.9.4.4—Crown Soil Cover Factor, C_H	12-45
12.9.4.5—Footing Reactions	12-45
12.9.4.6—Concrete Relieving Slabs.....	12-46
12.9.5—Construction and Installation	12-47
12.10—REINFORCED CONCRETE PIPE	12-47
12.10.1—General.....	12-47
12.10.2 Loading.....	12-48
12.10.2.1 Standard Installations.....	12-48
12.10.2.2 Pipe Fluid Weight	12-52
12.10.2.3—Live Loads	12-52
12.10.3—Service Limit State.....	12-52
12.10.4—Safety against Structural Failure	12-52

12.10.4.1—General.....	12-52
12.10.4.2—Direct Design Method.....	12-53
12.10.4.2.1—Loads and Pressure Distribution.....	12-53
12.10.4.2.2—Analysis for Force Effects with the Pipe Ring.....	12-54
12.10.4.2.3—Process and Material Factors.....	12-55
12.10.4.2.4—Flexural Resistance at the Strength Limit State.....	12-55
12.10.4.2.4a—Circumferential Reinforcement.....	12-55
12.10.4.2.4b—Minimum Reinforcement.....	12-55
12.10.4.2.4c—Maximum Flexural Reinforcement without Stirrups.....	12-56
12.10.4.2.4d—Reinforcement for Crack Width Control.....	12-57
12.10.4.2.4e—Minimum Concrete Cover.....	12-58
12.10.4.2.5—Shear Resistance without Stirrups.....	12-58
12.10.4.2.6—Shear Resistance with Radial Stirrups.....	12-60
12.10.4.2.7—Stirrup Reinforcement Anchorage.....	12-61
12.10.4.2.7a—Radial Tension Stirrup Anchorage.....	12-61
12.10.4.2.7b—Shear Stirrup Anchorage.....	12-61
12.10.4.2.7c—Stirrup Embedment.....	12-61
12.10.4.3—Indirect Design Method.....	12-61
12.10.4.3.1—Bearing Resistance.....	12-61
12.10.4.3.2—Bedding Factor.....	12-62
12.10.4.3.2a—Earth Load Bedding Factor for Circular Pipe.....	12-62
12.10.4.3.2b—Earth Load Bedding Factor for Arch and Elliptical Pipe.....	12-63
12.10.4.3.2c—Live Load Bedding Factors.....	12-64
12.10.4.4—Development of Quadrant Mat Reinforcement.....	12-64
12.10.4.4.1—Minimum Cage Reinforcement.....	12-64
12.10.4.4.2—Development Length of Welded Wire Fabric.....	12-64
12.10.4.4.3—Development of Quadrant Mat Reinforcement Consisting of Welded Plain Wire Fabric.....	12-64
12.10.4.4.4—Development of Quadrant Mat Reinforcement Consisting of Deformed Bars, Deformed Wire, or Deformed Wire Fabric.....	12-65
12.10.5—Construction and Installation.....	12-65
12.11—REINFORCED CONCRETE CAST-IN-PLACE AND PRECAST BOX CULVERTS AND REINFORCED CAST-IN-PLACE ARCHES.....	12-65
12.11.1—General.....	12-65
12.11.2—Loads and Live Load Distribution.....	12-66
12.11.2.1—General.....	12-66
12.11.2.2—Modification of Earth Loads for Soil-Structure Interaction.....	12-66
12.11.2.2.1—Embankment and Trench Conditions.....	12-66
12.11.2.2.2—Other Installations.....	12-69
12.11.2.3—Distribution of Concentrated Loads to Bottom Slab of Box Culvert.....	12-69
12.11.2.4—Distribution of Concentrated Loads in Skewed Box Culverts.....	12-69
12.11.3—Service Limit State.....	12-69
12.11.4—Safety against Structural Failure.....	12-70
12.11.4.1—General.....	12-70
12.11.4.2—Design Moment for Box Culverts.....	12-70
12.11.4.3—Minimum Reinforcement.....	12-70

12.11.4.3.1—Cast-in-Place Structures.....	12-70
12.11.4.3.2—Precast Box Structures.....	12-70
12.11.4.4—Minimum Cover for Precast Box Structures.....	12-71
12.11.5—Construction and Installation.....	12-71
12.12—THERMOPLASTIC PIPES.....	12-71
12.12.1—General.....	12-71
12.12.2—Service Limit States.....	12-71
12.12.2.1—General.....	12-71
12.12.2.2—Deflection Requirement.....	12-71
12.12.3—Safety against Structural Failure.....	12-73
12.12.3.1—General.....	12-73
12.12.3.2—Section Properties.....	12-73
12.12.3.3—Chemical and Mechanical Requirements.....	12-73
12.12.3.4—Thrust.....	12-74
12.12.3.5—Factored and Service Loads.....	12-74
12.12.3.6—Handling and Installation Requirements.....	12-78
12.12.3.7—Soil Prism.....	12-79
12.12.3.8—Hydrostatic Pressure.....	12-80
12.12.3.9—Live Load.....	12-80
12.12.3.10—Wall Resistance.....	12-81
12.12.3.10.1—Resistance to Axial Thrust.....	12-81
12.12.3.10.1a—General.....	12-81
12.12.3.10.1b—Local Buckling Effective Area.....	12-81
12.12.3.10.1c—Compression Strain.....	12-82
12.12.3.10.1d—Thrust Strain Limits.....	12-83
12.12.3.10.1e—General Buckling Strain Limits.....	12-83
12.12.3.10.2—Bending and Thrust Strain Limits.....	12-84
12.12.3.10.2a—General.....	12-84
12.12.3.10.2b—Combined Strain.....	12-84
12.12.4—Construction and Installation.....	12-86
12.13—STEEL TUNNEL LINER PLATE.....	12-87
12.13.1—General.....	12-87
12.13.2—Loading.....	12-87
12.13.2.1—Earth Loads.....	12-87
12.13.2.2—Live Loads.....	12-88
12.13.2.3—Grouting Pressure.....	12-88
12.13.3—Safety against Structural Failure.....	12-88
12.13.3.1—Section Properties.....	12-88
12.13.3.2—Wall Area.....	12-88
12.13.3.3—Buckling.....	12-89
12.13.3.4—Seam Strength.....	12-89
12.13.3.5—Construction Stiffness.....	12-89
12.14—PRECAST REINFORCED CONCRETE THREE-SIDED STRUCTURES.....	12-91
12.14.1—General.....	12-91

12.14.2—Materials.....	12-91
12.14.2.1—Concrete	12-91
12.14.2.2—Reinforcement.....	12-91
12.14.3—Concrete Cover for Reinforcement	12-91
12.14.4—Geometric Properties.....	12-91
12.14.5—Design	12-91
12.14.5.1—General.....	12-91
12.14.5.2—Distribution of Concentrated Load Effects in Top Slab and Sides.....	12-92
12.14.5.3—Distribution of Concentrated Loads in Skewed Culverts	12-92
12.14.5.4—Shear Transfer in Transverse Joints between Culvert Sections.....	12-92
12.14.5.5—Span Length	12-92
12.14.5.6—Resistance Factors.....	12-93
12.14.5.7—Crack Control.....	12-93
12.14.5.8—Minimum Reinforcement.....	12-93
12.14.5.9—Deflection Control at the Service Limit State	12-93
12.14.5.10—Footing Design.....	12-93
12.14.5.11—Structural Backfill.....	12-93
12.14.5.12—Scour Protection and Waterway Considerations	12-93
12.15—REFERENCES.....	12-94
APPENDIX A12—PLATE, PIPE, AND PIPE ARCH PROPERTIES.....	12-97

BURIED STRUCTURES AND TUNNEL LINERS

12.1—SCOPE

This Section provides requirements for the selection of structural properties and dimensions of buried structures, e.g., culverts, and steel plate used to support tunnel excavations in soil.

Buried structure systems considered herein are metal pipe, structural plate pipe, long-span structural plate, deep corrugated plate, structural plate box, reinforced concrete pipe, reinforced concrete cast-in-place and precast arch, box and elliptical structures, and thermoplastic pipe.

The type of liner plate considered is cold-formed steel panels.

12.2—DEFINITIONS

Abrasion—Loss of section or coating of a culvert by the mechanical action of water conveying suspended bed load of sand, gravel, and cobble-size particles at high velocities with appreciable turbulence.

Buried Structure—A generic term for a structure built by embankment or trench methods.

Corrosion—Loss of section or coating of a buried structure by chemical and/or electrochemical processes.

Culvert—A curved or rectangular buried conduit for conveyance of water, vehicles, utilities, or pedestrians.

Deep Corrugated Plate—Structural Plate in AASHTO M 167 with a corrugation depth greater than 5 in.

FEM—Finite Element Method

Narrow Trench Width—The outside span of rigid pipe, plus 1.0 ft.

Projection Ratio—Ratio of the vertical distance between the outside top of the pipe and the ground or bedding surface to the outside vertical height of the pipe, applicable to reinforced concrete pipe only.

Side Radius—For deep corrugated plate structures, the side radius is the radius of the plate in the section adjacent to crown (top) section of the structure. In box shaped structures, this is often called the haunch radius.

Soil Envelope—Zone of controlled soil backfill around culvert structure required to ensure anticipated performance based on soil-structure interaction considerations.

Soil-Structure Interaction System—A buried structure whose structural behavior is influenced by interaction with the soil envelope.

Tunnel—A horizontal or near horizontal opening in soil excavated to a predesigned geometry by tunneling methods exclusive of cut-and-cover methods.

12.3—NOTATION

A	=	wall area (in. ² /ft) (12.7.2.3)
A_{eff}	=	effective wall area (in. ² /in.) (12.12.2.2)
A_g	=	gross wall area within a length of one period (in. ² /in.) (12.12.3.5)
A_L	=	axle load, taken as 50 percent of all axle loads that can be placed on the structure at one time (kip); sum of all axle loads in an axle group (kip); total axle load on single axle or tandem axles (kip) (12.8.4.2) (12.9.4.2) (12.9.4.3)
A_s	=	tension reinforcement area on cross-section width, b (in. ² /ft) (C12.10.4.2.4a) (C12.11.3) (C12.11.4)
A_{smax}	=	minimum flexural reinforcement area without stirrups (in. ² /ft) (12.10.4.2.4c)
A_T	=	area of the top portion of the structure above the springline (ft ²) (12.8.4.2)

A_{vr}	=	stirrup reinforcement area to resist radial tension forces on cross-section width, b in each line of stirrups at circumferential spacing, s_v (in. ² /ft) (12.10.4.2.6)
A_{vs}	=	required area of stirrups for shear reinforcement (in. ² /ft) (12.10.4.2.6)
B	=	width of culvert (ft) (C12.6.2.2.5)
B_c	=	outside diameter or width of the structure (ft) (12.6.6.3)
B'_c	=	out-to-out vertical rise of pipe (ft) (12.6.6.3)
B_d	=	horizontal width of trench at top of pipe (ft) (12.11.2.2)
B_{FE}	=	earth load bedding factor (12.10.4.3.1)
B_{FLL}	=	live load bedding factor (12.10.4.3.1)
B_1	=	crack control coefficient for effect of cover and spacing of reinforcement (C12.10.4.2.4d)
b	=	width of section (12.10.4.2.4c)
b_e	=	element effective width (in.) (12.12.3.10.1b)
C_A	=	constant corresponding to the shape of the pipe (12.10.4.3.2a)
C_c	=	load coefficient for positive pipe projection (12.10.4.3.2a)
C_d	=	load coefficient for trench installation (12.11.2.2)
C_{dt}	=	load coefficient for tunnel installation (12.13.2.1)
C_H	=	adjustment factor for shallow cover heights over metal box culverts (12.9.4.4)
C_L	=	live load distribution coefficient (12.12.2.2)
C_n	=	calibration factor to account for nonlinear effects (12.12.3.10.1e)
$C_{\ell\ell}$	=	live load adjusted for axle loads, tandem axles, and axles with other than four wheels; $C_1 C_2 A_L$ (kip) (12.9.4.2)
C_N	=	parameter that is a function of the vertical load and vertical reaction (12.10.4.3.2a)
C_s	=	construction stiffness for tunnel liner plate (kip/in.) (12.5.6.4)
C_1	=	1.0 for single axles and $0.5 + S/50 \leq 1.0$ for tandem axles; adjustment coefficient for number of axles; crack control coefficient for various types of reinforcement (12.9.4.2) (12.9.4.3) (C12.10.4.2.4d)
C_2	=	adjustment factor for number of wheels on a design axle as specified in Table 12.9.4.2-1; adjustment coefficient for number of wheels per axle (12.9.4.2) (12.9.4.3)
D	=	straight leg length of haunch (in.); pipe diameter (in.); required D-load capacity of reinforced concrete pipe (klf); diameter to centroid of pipe wall (in.) (12.9.4.1) (12.6.6.2) (12.10.4.3.1) (12.12.2.2)
$D\text{-load}$	=	resistance of pipe from three-edge bearing test load to produce a 0.01-in. crack (klf) (12.10.4.3)
D_f	=	shape factor (12.12.3.10.2b)
D_i	=	inside diameter of pipe (in.) (12.10.4.3.1)
D_L	=	deflection lag factor (12.12.2.2)
D_o	=	outside diameter of pipe (in.) (12.12.2.2)
d	=	required envelope width adjacent to the structure (ft); distance from compression face to centroid of tension reinforcement (in.) (12.8.5.3) (12.10.4.2.4a) (C12.11.3)
d'	=	width of warped embankment fill to provide adequate support for skewed installation (ft) (C12.6.8.2)
d_1	=	distance from the structure (ft) (12.8.5.3)
E	=	modulus of elasticity of the plastic (ksi); initial modulus of elasticity (ksi) (12.12.3.3) (12.12.3.6)
E_m	=	modulus of elasticity of metal (ksi) (12.7.2.4)
E_p	=	short- or long-term modulus of pipe material as specified in Table 12.12.3.3-1 (ksi) (12.12.2.2)
$E(x)$	=	lateral unbalanced distributed load on culvert below sloping ground and skewed at end wall (lbs.) (C12.6.2.2.5)
E_{50}	=	50-yr modulus of elasticity (ksi) (12.12.3.3)
E_{75}	=	75-year modulus of elasticity (ksi) (12.12.3.3)
F	=	concentrated load acting at the crown of a culvert (kip) (C12.6.2.2.5)
F_c	=	curvature correction factor (12.10.4.2.5)
F_{cr}	=	factor for adjusting crack control relative to average maximum crack width of 0.01 in. corresponding to $F_{cr} = 1.0$ (12.10.4.2.4d)
F_d	=	factor for crack depth effect resulting in increase in diagonal tension, shear, and strength with decreasing d (12.10.4.2.5)
F_e	=	soil-structure interaction factor for embankment installations (12.10.2.1)
FF	=	flexibility factor (in./kip) (12.5.6.3) (12.7.2.6)
F_n	=	coefficient for effect of thrust on shear strength (12.10.4.2.5)
F_{rp}	=	factor for process and local materials affecting radial tension strength of pipe (12.10.4.2.3)
F_{rt}	=	factor for pipe size effect on radial tension strength (12.10.4.2.4c)
F_t	=	soil-structure interaction factor for trench installations (12.10.2.1)

F_u	=	specified minimum tensile strength (ksi); material yield strength for design load duration (ksi) (12.7.2.4) (12.12.3.10.1b)
F_{vp}	=	factor for process and local materials that affect the shear strength of the pipe (12.10.4.2.3)
F_y	=	yield strength of metal (ksi) (12.7.2.3)
f'_c	=	compressive strength of concrete (ksi) (12.4.2.2)
f_{cr}	=	critical buckling stress (ksi) (12.7.2.4)
f_s	=	maximum stress in reinforcing steel at service limit state (ksi) (C12.11.3)
f_y	=	specified minimum yield point for reinforcing steel (ksi) (12.10.4.2.4a)
H	=	rise of culvert (ft); height of cover from the box culvert rise to top of pavement (ft); height of cover over crown (ft); height of fill above top of pipe (ft) (C12.6.2.2.5) (12.9.4.2) (12.9.4.4) (12.10.2.1)
HAF	=	horizontal arching factor (12.10.2.1)
H_D	=	vertical distance from mid-depth of corrugation to top grade (12.8.9.4)
H_{design}	=	design height of cover above top of culvert or above crown of arches or pipes (ft) (C12.6.2.2.5)
H_L	=	headwall strip reaction (kip) (C12.6.2.2.5)
H_s	=	depth of water table above springline of pipe (ft) (12.12.3.4)
H_w	=	depth of water table above springline of pipe (ft) (12.12.3.7)
H_1	=	depth of crown of culvert below ground surfaces (ft); height of cover above the footing to traffic surface (ft) (C12.6.2.2.5) (12.8.4.2)
H_2	=	actual height of cover above top of culvert or above crown of arches or pipes (ft); height of cover from the structure springline to traffic surface (ft) (C12.6.2.2.5) (12.8.4.2)
h	=	vertical distance from the top of cover for design height to point of horizontal load application (ft); wall thickness of pipe or box culvert (in.); height of ground surface above top of pipe (ft) (C12.6.2.2.5) (12.10.4.2.4a) (C12.11.3)
I	=	moment of inertia (in. ⁴ /in.) (12.7.2.6)
ID	=	inside diameter (in.) (12.6.6.3)
IM	=	dynamic load allowance as specified in Table 3.6.1.1.2-1 (percent) (12.12.3.9)
I_p	=	moment of inertia of pipe profile per unit length of pipe (in. ⁴ /in.) (12.12.2.2)
i	=	coefficient for effect of axial force at service limit state, f_s (12.10.4.2.4d) (C12.11.3)
j	=	coefficient for moment arm at service limit state, f_s (12.10.4.2.4d) (C12.11.3)
K	=	ratio of the unit lateral effective soil pressure to unit vertical effective soil pressure, i.e., Rankine coefficient of active earth pressure (12.10.4.2)
K_B	=	bedding coefficient (12.12.2.2)
K_h	=	lateral earth pressure for culvert under sloping ground (psf/lf) (C12.6.2.2.5)
K_{h1}	=	lateral earth pressure distribution acting on upslope surface of culvert (psf/lf) (C12.6.2.2.5)
K_{h2}	=	lateral earth pressure distribution acting on downslope surface of culvert (psf/lf) (C12.6.2.2.5)
K_t	=	time factor as specified in Table 12.12.3.10.1b-1 (12.12.3.10.1b)
K_{wa}	=	factor for uncertainty in level of ground water table (12.12.3.8)
K_1	=	coefficient to consider design location (in.) (12.12.3.9)
K_2	=	coefficient to account for thrust variation around circumference (12.12.3.5)
K_{yE}	=	installation factor (12.12.3.5)
k	=	soil stiffness factor; edge support coefficient; plate buckling coefficient (12.7.2.4) (12.13.3.3) (12.12.3.10.1b)
L	=	distance along length of culvert from expansion joint to the centerline of the headwall (ft); length of stiffening rib on leg (in.) (C12.6.2.2.5) (12.9.4.1)
$LLDF$	=	factor for distribution of live load through earth fills as specified in Article 3.6.1.2.6 (12.12.3.5)
L_0	=	length of live load surface contact area parallel to pipe diameter as specified in Article 3.6.1.2.5 (in.) (12.12.3.9)
L_w	=	lane width (ft); horizontal live load distribution width in the circumferential direction, at the elevation of the crown (in.) (12.8.4.2) (12.12.3.5)
M_{dl}	=	dead load moment (kip-ft/ft); sum of the nominal crown and haunch dead load moments (kip-ft/ft) (12.9.4.2)
M_{dtu}	=	factored dead load moment as specified in Article 12.9.4.2 (kip-ft) (12.9.4.3)
$M_{\ell\ell}$	=	live load moment (kip-ft/ft); sum of the nominal crown and haunch live load moments (kip-ft/ft) (12.9.4.2)
$M_{\ell\ell u}$	=	factored live load moment as specified in Article 12.9.4.2 (kip-ft) (12.9.4.3)
M_{nu}	=	factored moment acting on cross-section width, b , as modified for effects of compressive or tensile thrust (kip-in./ft) (12.10.4.2.6)
M_p	=	plastic moment capacity of deep corrugated structure (k-ft/ft) (12.8.9.4)
M_{pc}	=	crown plastic moment capacity (kip-ft/ft) (12.9.4.3)

M_{ph}	=	haunch plastic moment capacity (kip-ft/ft) (12.9.4.3)
M_s	=	bending moment at service limit state (kip-in./ft); moment acting on a cross-section of width, b , at service limit state taken as an absolute value in design equations (kip-in./ft); constrained soil modulus specified in Table 12.12.3.5-1 (ksi); soil modulus (ksi) (12.10.4.2.4d) (C12.11.3) (12.12.2.2) (12.12.3.5)
M_u	=	ultimate moment acting on cross-section width, b (kip-in./ft) (12.10.4.2.4a)
m	=	multiple presence factor as specified in Table 3.6.1.1.2-1 (12.12.3.9)
N_s	=	axial thrust acting on a cross-section width, b , at service limit state taken as positive when compressive and negative when tensile (kip/ft) (12.10.4.2.4d) (C12.11.3)
N_u	=	axial thrust acting on cross-section width, b , at strength limit state (kip/ft) (12.10.4.2.4a)
n	=	number of adjoining traffic lanes (12.8.4.2)
P	=	design wheel load as specified in Article 3.6.2.2 (lb) (12.12.3.9)
P_{Brg}	=	allowable bearing pressure to limit compressive strain in the trench wall or embankment (ksf) (12.8.5.3)
P_c	=	proportion of total moment carried by crown of metal box culvert (12.9.4.3)
P_F	=	factored vertical crown pressure due to earth and live loads (ksf) (12.7.2.2)
P_L	=	pressure due to live load (LL) and dynamic load allowance (IM) (psi); service load on culvert (12.12.2.2) (12.12.3.9)
P_s	=	design service load (psi) (12.12.2.2)
P_{sp}	=	soil prism pressure (psi) (12.12.2.2)
P_{st}	=	stub compression capacity from T 341 (lb/in.) (12.12.3.10.1b)
P_u	=	design factored load (psi) (12.12.3.5)
P_w	=	hydrostatic water pressure (psi) (12.12.3.5)
P_1	=	horizontal pressure from the structure at a distance, d_1 (ksf) (12.8.5.3)
p	=	positive projection ratio (12.10.4.3.2a)
p'	=	negative projection ratio (12.10.4.3.2a)
q	=	ratio of the total lateral pressure to the total vertical pressure (12.10.4.3.2a)
R	=	rise of structure (ft); rise of box culvert or long-span structural plate structures (ft); radius to centroid of pipe wall profile (in.) (12.8.4.1) (12.9.4.1) (12.12.2.2)
R_{AL}	=	axle load correction factor (12.9.4.6)
R_c	=	corner radius of the structure (ft); concrete strength correction factor (12.8.5.3) (12.9.4.6)
R_d	=	ratio of resistance factors specified in Article 5.5.4.2 for shear and moment (12.10.4.2.4c)
R_f	=	factor related to required relieving slab thickness, applicable for box structures where the span is less than 26.0 ft (12.9.4.6)
R_H	=	horizontal footing reaction component (kip/ft) (12.8.4.2)
R_h	=	haunch moment reduction factor; correction factor for backfill soil geometry (12.9.4.3) (12.12.3.10.1e)
R_n	=	nominal resistance (klf) (12.5.1)
R_r	=	factored resistance (klf); factored resistance to thrust (kip/ft) (12.5.1) (12.12.3.5)
R_T	=	top arc radius of long-span structural plate structures (ft) (12.8.3.2)
R_V	=	vertical footing reaction component (kip/ft) (12.8.4.2)
r	=	radius of gyration (in.); radius to centerline of concrete pipe wall (in.) (12.7.2.4) (12.10.4.2.5)
r_c	=	radius of crown (ft) (12.9.4.1)
r_h	=	radius of haunch (ft) (12.9.4.1)
r_s	=	radius of the inside reinforcement (in.) (12.10.4.2.4c)
r_{sd}	=	settlement ratio parameter (12.10.4.3.2a)
S	=	pipe, tunnel, or box diameter or span (in.) or (ft) as indicated; span of structure between springlines of long-span structural plate structures (ft); box culvert span (ft) (12.6.6.3) (12.8.4.1) (12.9.4.2) (12.12.3.6)
S_H	=	hoop stiffness factor (12.12.3.5)
S_i	=	internal diameter or horizontal span of the pipe (in.) (12.10.4.2.4b)
S_ℓ	=	spacing of circumferential reinforcement (in.) (12.10.4.2.4d)
S_1, S_2	=	shear forces acting along culvert bearing lines (lbs.) (C12.6.2.2.5)
s_v	=	spacing of stirrups (in.) (12.10.4.2.6)
T	=	total dead load and live load thrust in the structure (kip/ft) (12.8.5.3)
T_L	=	factored thrust (kip/ft) (12.7.2.2)
T_s	=	service thrust per unit length (lb/in.) (12.12.2.2)
T_u	=	factored thrust per unit length (lb/in.) (12.12.3.10.1c)
t	=	required thickness of cement concrete relieving slab (in.); thickness of element (in.) (12.9.4.6) (12.12.3.10.1b)
t_b	=	basic thickness of cement concrete relieving slab (in.); clear cover over reinforcement (in.) (12.9.4.6) (12.10.4.2.4d)
V	=	unfactored footing reaction (kip/ft) (12.9.4.5)

V_{AF}	=	vertical arching factor (12.10.2.1)
V_c	=	factored shear force acting on cross-section width, b , which produces diagonal tension failure without stirrup reinforcement (kip/ft) (12.10.4.2.6)
V_{DL}	=	$[H_2(S) - A_T] \gamma_s/2$ (kip/ft) (12.8.4.2)
V_L	=	headwall strip reaction (kip) (C12.6.2.2.5)
V_{LL}	=	$n(A_L)/(8 + 2 H_1)$ (kip/ft) (12.8.4.2)
V_n	=	nominal shear resistance of pipe section without radial stirrups per unit length of pipe (kip/ft) (12.10.4.2.5)
V_r	=	factored shear resistance per unit length (kip/ft) (12.10.4.2.5)
V_u	=	ultimate shear force acting on cross-section width, b (kip/ft) (12.10.4.2.5)
W_E	=	total earth load on pipe or liner (kip/ft) (12.10.2.1)
W_F	=	fluid load in the pipe (kip/ft) (12.10.4.3.1)
W_L	=	total live load on pipe or liner (kip/ft) (12.10.4.3.1)
W_0	=	width of live load ground-surface contact area parallel to flow in pipe (in.) (12.12.3.5)
W_T	=	total dead and live load on pipe or liner (kip/ft) (12.10.4.3.1)
w	=	unit weight of soil (pcf); total clear width of element between supporting elements (in.) (12.10.2.1) (12.12.3.10.1b)
x	=	parameter which is a function of the area of the vertical projection of the pipe over which active lateral pressure is effective (12.10.4.3.2a)
α	=	skew angle between the highway centerline or tangent thereto and the culvert headwall (degrees) (C12.6.2.2.5)
β	=	angle of fill slope measured from horizontal (degrees) (C12.6.2.2.5)
γ_b	=	unit weight of buoyant soil (lb/ft ³) (12.12.3.7)
γ_{EV}	=	load factor for vertical pressure from dead load of earth fill (12.12.3.5)
γ_{LL}	=	load factor for live load (12.12.3.5)
γ_s	=	unit weight of backfill (kcf) ; soil unit weight (kcf); wet unit weight of soil (lb/ft ³) (C12.9.2) (12.9.4.2) (12.12.3.7)
γ_w	=	unit weight of water (lb/ft ³) (12.12.3.8)
γ_{WA}	=	load factor for hydrostatic pressure (12.12.3.5)
Δ_A	=	total allowable deflection of pipe (in.) (12.12.2.2)
Δ_f	=	deflection of pipe due to flexure (in.) (12.12.3.10.2b)
Δ_t	=	total deflection of pipe (in.) (12.12.2.2)
ϵ_{bck}	=	nominal strain capacity for general buckling (12.12.3.10.1e)
ϵ_f	=	factored strain due to flexure (12.12.3.10.2b)
ϵ_{sc}	=	service compressive strain (in./in.) (12.12.2.2)
ϵ_{uc}	=	factored compressive strain due to thrust (12.12.3.10.1c)
ϵ_{yc}	=	factored compressive strain limit as specified in Table 12.12.3.3-1 (12.12.3.10.1b)
ϵ_{yt}	=	service long-term strain limit as specified in Table 12.12.3.3-1 (12.12.3.10.2b)
η_{EV}	=	load modifier, specified in Article 1.3.2, as they apply to vertical earth loads on culverts (12.12.3.5)
η_{LL}	=	load modifier as they apply to live loads on culverts (12.12.3.5)
λ	=	slenderness factor (12.12.3.10.1b)
μ	=	coefficient of friction between the pipe and soil (12.10.2.1)
ν	=	Poisson's ratio of soil (12.12.3.10.1e)
ρ	=	effective width factor (12.12.3.10.1b)
ϕ	=	resistance factor (12.5.1)
ϕ_{bck}	=	resistance factor for buckling (12.12.3.10.1e)
ϕ_f	=	resistance factor for flexure (12.10.4.2.4c)
ϕ_{fs}	=	coefficient of friction between the fill material and the sides of the trench (12.10.4.3.2a)
ϕ_r	=	resistance factor for radial tension (12.10.4.2.4c)
ϕ_s	=	resistance factor for soil stiffness, $\phi_s = 0.9$; resistance factor for soil pressure (12.12.3.5) (12.12.3.10.1e)
ϕ_T	=	resistance factor for thrust effects (12.12.3.10.1d)
Ψ	=	central angle of pipe subtended by assumed distribution of external reactive force (degrees) (12.10.4.2.1)
ω	=	spacing of corrugation (in.) (12.12.3.10.1b)

12.4—SOIL AND MATERIAL PROPERTIES

12.4.1—Determination of Soil Properties

12.4.1.1—General

Subsurface exploration shall be carried out to determine the presence and influence of geologic and environmental conditions that may affect the performance of buried structures. For buried structures supported on footings and for pipe arches and large diameter pipes, a foundation investigation should be conducted to evaluate the capacity of foundation materials to resist the applied loads and to satisfy the movement requirements of the structure.

12.4.1.2—Foundation Soils

The type and anticipated behavior of the foundation soil shall be considered for stability of bedding and settlement under load.

12.4.1.3—Envelope Backfill Soils

The type, compacted density and strength properties of the soil envelope adjacent to the buried structure shall be established. The backfill soils comprising the soil envelope shall conform to the requirements of AASHTO M 145 as follows:

- For standard flexible pipes and concrete structures: A-1, A-2, or A-3 (GW, GP, SW, SP, GM, SM, SC, GC),
- For metal box culverts and long-span structures with cover less than 12.0 ft: A-1, A-2-4, A-2-5, or A-3 (GW, GP, SW, SP, GM, SM, SC, GC),
- For long-span metal structures with cover not less than 12.0 ft: A-1 or A-3 (GW, GP, SW, SP, GM, SM), and
- For structural plate culverts with deep corrugations: A-1, A-2-4, A-2-5, or A-3 (ASTM D2487) (GW, GP, SW, SP, GM, SM, SC, GC) and the culvert manufacturer's requirements.
- For thermoplastic culverts, bedding, and backfill materials: A-1, A-2-4, A-2-5, or A-3 soils. A maximum of 50 percent of the particle sizes may pass the No. 100 sieve and a maximum of 20 percent may pass the No. 200 sieve.

C12.4.1.1

The following information may be useful for design:

- Strength and compressibility of foundation materials;
- Chemical characteristics of soil and surface waters, e.g., pH, resistivity, and chloride content of soil and pH, resistivity, and sulfate content of surface water;
- Stream hydrology, e.g., flow rate and velocity, maximum width, allowable headwater depth, and scour potential; and
- Performance and condition survey of culverts in the vicinity.

C12.4.1.2

Refer to Article 10.4 for general guidance regarding foundation soil properties. The performance of rigid pipes is dependent on foundation and bedding stability.

C12.4.1.3

Refer to Sections 26, 27, and 30 of the *AASHTO LRFD Bridge Construction Specifications*, for compaction criteria of soil backfill for flexible and rigid culverts.

Wall stresses in buried structure are sensitive to the relative stiffness of the soil and pipe. Buckling stability of flexible culverts is dependent on soil stiffness.

In the selection of a type of backfill for the envelope, the quality of the material and its suitability for achieving the requirements of the design should be considered. The order of preference for selecting envelope backfill based on quality may be taken as follows:

- Angular, well-graded sand and gravel;
- Nonangular, well-graded sand and gravel;
- Flowable materials, e.g., cement-soil-fly ash mixtures, which result in low density/low strength backfill, for trench applications only;
- Uniform sand or gravel, provided that placement is confirmed to be dense and stable, but which may require a soil or geofabric filter to prevent the migration of fines;
- Clayey sand or gravel of low plasticity; and
- Stabilized soil, which should be used only under the supervision of an Engineer familiar with the behavior of the material.

The restriction on materials passing the No. 100 sieve and No. 200 sieve for thermoplastic culverts are intended to eliminate uniform fine sands for use as pipe embedment. Such materials are difficult to work with, are sensitive to moisture content, and do not provide support comparable to coarser or more broadly graded materials at the same percentage of maximum density. The Engineer may permit exceptions to these restrictions in special cases. If so, a suitable plan should be submitted for control of moisture content and compaction procedures. These silty and clayey materials should never be used in a wet site. Increased inspection levels should be considered if such a plan is approved.

12.4.2—Materials

12.4.2.1—Aluminum Pipe and Structural Plate Structures

Aluminum for corrugated metal pipe and pipe-arches shall comply with the requirements of AASHTO M 196 (ASTM B745). Aluminum for structural plate pipe, pipe-arch, arch, and box structures shall meet the requirements of AASHTO M 219 (ASTM B746).

12.4.2.2—Concrete

Concrete shall conform to Article 5.4, except that f'_c may be based on cores.

12.4.2.3—Precast Concrete Pipe

Precast concrete pipe shall comply with the requirements of AASHTO M 170 (ASTM C76) and M 242M/M 242 (ASTM C655M and C655). Design wall thickness, other than the standard wall dimensions, may be used, provided that the design complies with all applicable requirements of this Section.

12.4.2.4—Precast Concrete Structures

Precast concrete arch, elliptical, and box structures shall comply with the requirements of AASHTO M 206M/M 206 (ASTM C506M and C506), M 207M/M 207 (ASTM C507M and C507), M 259 (ASTM C789), and M 273 (ASTM C850).

12.4.2.5—Steel Pipe and Structural Plate Structures

Steel for corrugated metal pipe and pipe-arches shall comply with the requirements of AASHTO M 36 (ASTM A760). Steel for structural plate pipe, pipe-arch, arch, and box structures shall meet the requirements of AASHTO M 167M/M 167 (ASTM A761/A761M).

12.4.2.6—Deep Corrugated Structures

Steel for deep corrugated structural plate shall comply with the requirements of AASHTO M 167. Deep corrugated structural plate may be reinforced.

12.4.2.7—Steel Reinforcement

Reinforcement shall comply with the requirements of Article 5.4.3, and shall conform to one of the following: AASHTO M 31M/M 31 (ASTM A615/A615M), M 32M/M 32 (ASTM A82/A82M), M 55M/M 55 (ASTM A185/A185M), M 221M/M 221 (ASTM A497), or M 225M/M 225 (ASTM A496/A496M).

For smooth wire and smooth welded wire fabric, the yield strength may be taken as 65.0 ksi. For deformed welded wire fabric, the yield strength may be taken as 70.0 ksi.

12.4.2.8—Thermoplastic Pipe

Plastic pipe may be solid wall, corrugated, or profile wall and may be manufactured of polyethylene (PE) or polyvinyl chloride (PVC).

PE pipe shall comply with the requirements of ASTM F714 for solid wall pipe, AASHTO M 294 for corrugated pipe, and ASTM F894 for profile wall pipe.

PVC pipe shall comply with the requirements of AASHTO M 278 for solid wall pipe, ASTM F679 for solid wall pipe, and AASHTO M 304 for profile wall pipe.

C12.4.2.6

Reinforcement for deep corrugated structures may consist of structural shapes, or deep corrugated structural plate meeting the requirements of AASHTO M 167, with or without nonshrink grout, complete with shear studs.

C12.4.2.8

The AASHTO materials specifications also include a provisional specification, MP 20, for steel-reinforced polyethylene pipe (PE) ribbed pipe, 12.0 to 36.0 in. diameter. The steel ribs are the main load carrying members for the pipe and the thermoplastic material braces the steel ribs from distortion or buckling. The thermoplastic also distributes the load between the ribs. It is necessary to evaluate the composite system of thermoplastic liner and steel rib for adequacy. It is important to ensure that the tensile strains within the thermoplastic do not exceed the long-term strain capacity for the thermoplastic material used in the construction of the pipe. Three-dimensional finite element analysis of the profile which has been calibrated against results for full scale tests is recommended. Design specifications for this product will be considered for inclusion in these Specifications when a satisfactory number of instrumented installations are documented to validate performance.

12.5—LIMIT STATES AND RESISTANCE FACTORS**12.5.1—General**

Buried structures and their foundations shall be designed by the appropriate methods specified in Articles 12.7 through 12.12 so that they resist the factored loads given by the load combinations specified in Articles 12.5.2 and 12.5.3.

The factored resistance, R_r , shall be calculated for each applicable limit state as:

$$R_r = \phi R_n \quad (12.5.1-1)$$

C12.5.1

Procedures for determining nominal resistance are provided in Articles 12.7 through 12.12 for:

- Metal pipe, pipe arches, and arch structures;
- Long-span structural plate;
- Structural plate box structures;
- Reinforced precast concrete pipe;

where:

R_n = the nominal resistance

ϕ = the resistance factor specified in Table 12.5.5-1

- Reinforced concrete cast-in-place and precast box structures
- Thermoplastic pipe; and
- Deep corrugated structural plate structures.

12.5.2—Service Limit State

Buried structures shall be investigated at Service Load Combination I, as specified in Table 3.4.1-1.

- Deflection of metal structures, tunnel liner plate, and thermoplastic pipe, and
- Crack width in reinforced concrete structures.

12.5.3—Strength Limit State

Buried structures and tunnel liners shall be investigated for construction loads and at Strength Load Combinations I and II, as specified in Table 3.4.1-1, as follows:

- For metal structures:
 - Wall area
 - Buckling
 - Seam failure
 - Flexibility limit for construction
 - Flexure of box and deep corrugated structures only
- For concrete structures:
 - Flexure
 - Shear
 - Thrust
 - Radial tension
- For thermoplastic pipe:
 - Wall area
 - Buckling
 - Flexibility limit
- For tunnel liner plate:
 - Wall area
 - Buckling
 - Seam strength
 - Construction stiffness

12.5.4—Load Modifiers and Load Factors

Load modifiers shall be applied to buried structures and tunnel liners as specified in Article 1.3, except that the load modifiers for construction loads should be taken

C12.5.2

Deflection of a tunnel liner depends significantly on the amount of overexcavation of the bore and is affected by delay in backpacking or inadequate backpacking. The magnitude of deflection is not primarily a function of soil modulus or the liner plate properties, so it cannot be computed with usual deflection formulae.

Where the tunnel clearances are important, the designer should oversize the structure to allow for deflection.

C12.5.3

Strength Load Combinations III and IV and the extreme event limit state do not control due to the relative magnitude of loads applicable to buried structures as indicated in Article 12.6.1. Buried structures have been shown not to be controlled by fatigue.

Flexibility limit requirement is waived for some metal structures. See design provisions in Article 12.8.

Thermoplastic pipe have many profile wall geometries and some of these are made up of thin sections that may be limited based on local buckling. The strength limit state for wall area includes evaluating the section capacity for local buckling.

as 1.0. For strength limit states, buried structures shall be considered nonredundant under earth fill and redundant under live load and dynamic load allowance loads. Operational classification shall be determined on the basis of continued function and/or safety of the roadway.

12.5.5—Resistance Factors

Resistance factors for buried structures shall be taken as specified in Table 12.5.5-1. Values of resistance factors for the geotechnical design of foundations for buried structures shall be taken as specified in Section 10.

C12.5.5

The standard installations for direct design of concrete pipe were developed based on extensive parameter studies using the soil structure interaction program, SPIDA. Although past research validates that SPIDA soil structure models correlate well with field measurements, variability in culvert installation methods and materials suggests that the design for Type I installations be modified. This revision reduces soil structure interaction for Type I installations by ten percent until additional performance documentation on installation in the field is obtained.

The new thermoplastic design method evaluates more load conditions than prior specifications. Separate resistance factors are provided for each mode of behavior. The resistance factor for buckling is set at 0.7 and preserves the same level of safety as prior editions of these Specifications with the inclusion of the installation factor of Article 12.12.3.5. Buckling is an undesirable failure mode for culverts. Buckling can result in near total collapse of the culvert and blockage of the waterway.

Table 12.5.5-1—Resistance Factors for Buried Structures

Structure Type	Resistance Factor
Metal Pipe, Arch, and Pipe Arch Structures	
Helical pipe with lock seam or fully welded seam: • Minimum wall area and buckling	1.00
Annular pipe with spot-welded, riveted, or bolted seam: • Minimum wall area and buckling • Minimum longitudinal seam strength • Bearing resistance to pipe arch foundations	1.00 0.67 Refer to Section 10
Structural plate pipe: • Minimum wall area and buckling • Minimum longitudinal seam strength • Bearing resistance to pipe arch foundations	1.00 0.67 Refer to Section 10
Long-Span Structural Plate and Tunnel Liner Plate Structures	
• Minimum wall area • Minimum seam strength • Bearing resistance of pipe arch foundations	0.67 0.67 Refer to Section 10
Structural Plate Box Structures	
• Plastic moment strength • Bearing resistance of pipe arch foundations	1.00 Refer to Section 10
Reinforced Concrete Pipe	
Direct design method: Type 1 installation: • Flexure • Shear • Radial tension Other type installations: • Flexure • Shear • Radial tension	0.90 0.82 0.82 1.00 0.90 0.90
Reinforced Concrete Cast-in-Place Box Structures	
• Flexure • Shear	0.90 0.85
Reinforced Concrete Precast Box Structures	
• Flexure • Shear	1.00 0.90
Reinforced Concrete Precast Three-Sided Structures	
• Flexure • Shear	0.95 0.90
Thermoplastic Pipe	
PE and PVC pipe: • Thrust, ϕ_T • Soil stiffness, ϕ_s • Global buckling, ϕ_{bck} • Flexure, ϕ_f	1.00 0.90 0.70 1.00
Deep Corrugated Structural Plate Structures	
• Minimum wall area and general buckling, ϕ_b • Plastic hinge, ϕ_h • Soil, ϕ_s	0.70 0.90 0.90

12.5.6—Flexibility Limits and Construction Stiffness

12.5.6.1—Corrugated Metal Pipe and Structural Plate Structures

Flexibility factors for corrugated metal pipe and structural plate structures shall not exceed the values specified in Table 12.5.6.1-1.

C12.5.6.1

Limits on construction stiffness and plate flexibility are construction requirements that do not represent any limit state in service.

Table 12.5.6.1-1—Flexibility Factor Limit

Type of Construction Material	Corrugation Size (in.)	Flexibility Factor (in./kip)
Steel Pipe	0.25	43
	0.5	43
	1.0	33
Aluminum Pipe	0.25 and 0.50	
	0.060 Material Thk.	31
	0.075 Material Thk.	61
	All Others	92
	1.0	60
Steel Plate	6.0 × 2.0	
	Pipe	20
	Pipe-Arch	30
	Arch	30
Aluminum Plate	9.0 × 2.5	
	Pipe	25
	Pipe-Arch	36
	Arch	36

12.5.6.2—Spiral Rib Metal Pipe and Pipe Arches

Flexibility factors for spiral rib metal pipe and pipe arches shall not exceed the values, specified in Table 12.5.6.2-1, for embankment installations conforming to the provisions of Articles 12.6.6.2 and 12.6.6.3 and for trench installations conforming to the provisions of Articles 12.6.6.1 and 12.6.6.3.

Table 12.5.6.2-1—Flexibility Factor Limits

Material	Condition	Corrugation Size (in.)	Flexibility Factor (in./kip)
Steel	Embankment	0.75 × 0.75 × 7.5	$217I^{1/3}$
		0.75 × 1.0 × 11.5	$140I^{1/3}$
	Trench	0.75 × 0.75 × 7.5	$263I^{1/3}$
		0.75 × 1.0 × 11.5	$163I^{1/3}$
Aluminum	Embankment	0.75 × 0.75 × 7.5	$340I^{1/3}$
		0.75 × 1.0 × 11.5	$175I^{1/3}$
	Trench	0.75 × 0.75 × 7.5	$420I^{1/3}$
		0.75 × 1.0 × 11.5	$215I^{1/3}$

Values of inertia, I , for steel and aluminum pipes and pipe arches shall be taken as tabulated in Tables A12-2 and A12-5.

12.5.6.3—Flexibility Limits and Construction Stiffness—Thermoplastic Pipe

Flexibility factor, FF , of thermoplastic pipe shall not exceed 95.0 in./kip.

12.5.6.4—Steel Tunnel Liner Plate

Construction stiffness, C_s , in kip/in., shall not be less than the following:

- Two-flange liner plate
 $C_s \geq 0.050$ (kip/in.)
- Four-flange liner plate
 $C_s \geq 0.111$ (kip/in.)

12.6—GENERAL DESIGN FEATURES

12.6.1—Loading

Buried structures shall be designed for force effects resulting from horizontal and vertical earth pressure, pavement load, live load, and vehicular dynamic load allowance. Earth surcharge, live load surcharge, downdrag loads, and external hydrostatic pressure shall be evaluated where construction or site conditions warrant. Water buoyancy loads shall be evaluated for buried structures with inverts below the water table to control flotation, as indicated in Article 3.7.2. Earthquake loads should be considered only where buried structures cross active faults.

For vertical earth pressure, the maximum load factor from Table 3.4.1-2 shall apply.

Wheel loads shall be distributed through earth fills according to the provisions of Article 3.6.1.2.6.

C12.5.6.3

PE and PVC are thermoplastic materials that exhibit higher flexibility factors at high temperatures and lower flexibility factors at low temperatures. The specified flexibility factor limits are defined in relation to pipe stiffness values in accordance with ASTM D2412 at 73.4°F.

C12.5.6.4

Assembled liner using two- and four-flange liner plates does not provide the same construction stiffness as a full steel ring with equal stiffness.

C12.6.1

Buried structures benefit from both earth shelter and support that reduce or eliminate from concern many of the loads and load combinations of Article 3.4. Wind, temperature, vehicle braking, and centrifugal forces typically have little effect due to earth protection. Structure dead load, pedestrian live load, and ice loads are insignificant in comparison with force effects due to earth fill loading. External hydrostatic pressure, if present, can add significantly to the total thrust in a buried pipe.

Vehicular collision forces are applicable to appurtenances such as headwalls and railings only. Water, other than buoyancy and vessel collision loads, can act only in the noncritical longitudinal direction of the culvert.

Due to the absence or low magnitude of these loadings, Service Load Combination I, Strength Load Combinations I and II, or construction loads control the design.

The finite element analyses used in the preparation of these metal box structure provisions are based on conservative soil properties of low plasticity clay (CL) compacted to 90 percent density as specified in AASHTO T 99. Although low plasticity clay is not considered an acceptable backfill material, as indicated in Article 12.4.1.3, the FEM results have been shown to yield conservative, upperbound moments.

The loading conditions that cause the maximum flexural moment and thrust are not necessarily the same, nor are they necessarily the conditions that will exist at the final configuration.

12.6.2—Service Limit State

12.6.2.1—Tolerable Movement

Tolerable movement criteria for buried structures shall be developed based on the function and type of structure, anticipated service life, and consequences of unacceptable movements.

12.6.2.2—Settlement

12.6.2.2.1—General

Settlement shall be determined as specified in Article 10.6.2. Consideration shall be given to potential movements resulting from:

- Longitudinal differential settlement along the length of the pipe,
- Differential settlement between the pipe and backfill, and
- Settlement of footings and unbalanced loading of skewed structures extending through embankment slopes.

12.6.2.2.2—Longitudinal Differential Settlement

Differential settlement along the length of buried structures shall be determined in accordance with Article 10.6.2.4. Pipes and culverts subjected to longitudinal differential settlements shall be fitted with positive joints to resist disjoining forces meeting the requirements of Sections 26 and 27, *AASHTO LRFD Bridge Construction Specifications*.

Camber may be specified for an installation to ensure hydraulic flow during the service life of the structure.

12.6.2.2.3—Differential Settlement between Structure and Backfill

Where differential settlement of arch structures is expected between the structure and the side fill, the foundation should be designed to settle with respect to the backfill.

Pipes with inverts shall not be placed on foundations that will settle much less than the adjacent side fill, and a uniform bedding of loosely compacted granular material should be provided.

12.6.2.2.4—Footing Settlement

Footings shall be designed to provide uniform longitudinal and transverse settlement. The settlement of footings shall be large enough to provide protection against possible downdrag forces caused by settlement of adjacent fill. If poor foundation materials are encountered, consideration shall be given to excavation

C12.6.2.2.3

The purpose of this provision is to minimize downdrag loads.

C12.6.2.2.4

Metal pipe arch structures, long-span arch structures, and box culvert structures should not be supported on foundation materials that are relatively unyielding compared with the adjacent sidefill. The use of massive footings or piles to prevent settlement of such structures is not recommended.

of all or some of the unacceptable material and its replacement with compacted acceptable material.

Footing design shall comply with the provisions of Article 10.6.

Footing reactions for metal box culvert structures shall be determined as specified in Article 12.9.4.5.

The effects of footing depth shall be considered in the design of arch footings. Footing reactions shall be taken as acting tangential to the arch at the point of connection to the footing and to be equal to the thrust in the arch at the footing.

12.6.2.2.5—Unbalanced Loading

Buried structures skewed to the roadway alignment and extending through an embankment fill shall be designed in consideration of the influence of unsymmetrical loading on the structure section.

In general, provisions to accommodate uniform settlement between the footings are desirable, provided that the resulting total settlement is not detrimental to the function of the structure.

C12.6.2.2.5

Disregard of the effect of lateral unbalanced forces in the headwall design can result in failure of the headwall and adjacent culvert sections.

Due to the complexity of determining the actual load distribution on a structure subjected to unbalanced loading, the problem can be modeled using numerical methods or the following approximate method. The approximate method consists of analyzing 1.0-ft wide culvert strips for the unbalanced soil pressures wherein the strips are limited by planes perpendicular to the culvert centerline. Refer to Figure C12.6.2.2.5-1 for this method of analysis for derivation of force F . For semicomplete culvert strips, the strips may be assumed to be supported as shown in the lower part of the plan. The headwall shall be designed as a frame carrying the strip reactions, V_L and $H_L \cos \alpha$, in addition to the concentrated force, F , assumed to be acting on the crown. Force F is determined using the equations given herein.

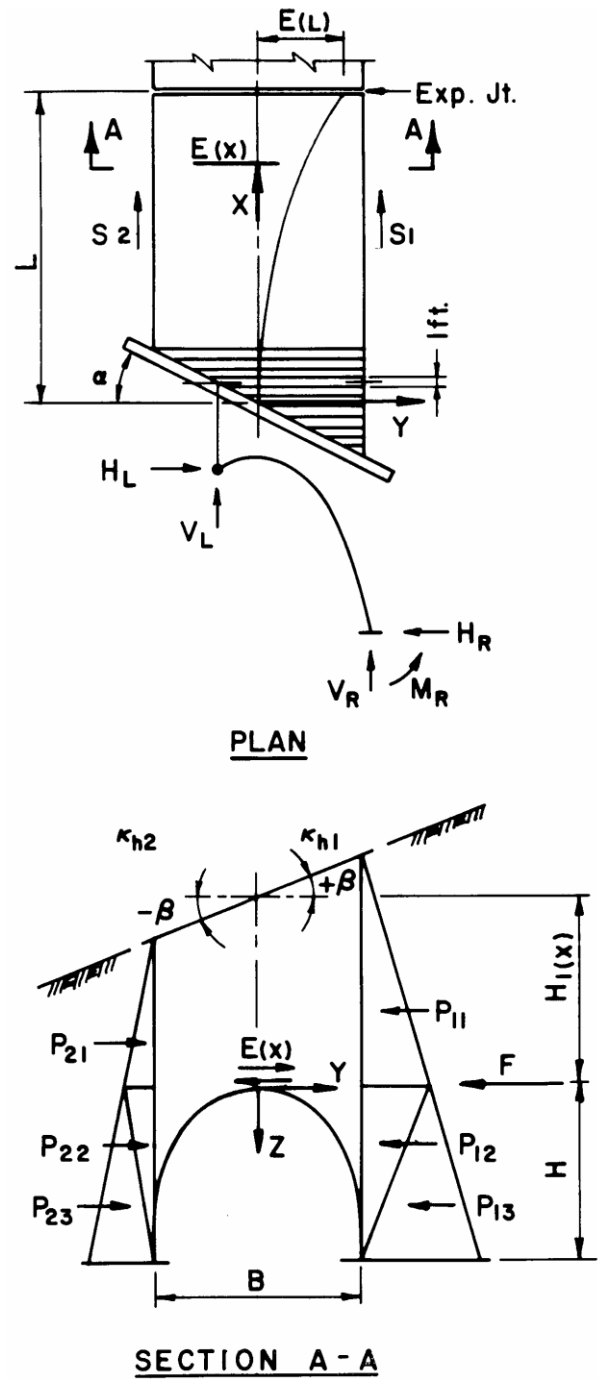

Figure C12.6.2.2.5-1—Forces on Culvert—Approximate Analysis

The unbalanced distributed load may be estimated by the following relationships:

$$E(x) = (P_{11} - P_{21}) + \frac{2}{3}(P_{12} - P_{22}) + \frac{1}{3}(P_{13} - P_{23}) \tag{C12.6.2.2.5-1}$$

in which:

$$\begin{aligned}
 P_{11} &= \frac{1}{2} K_{h1} \left(H_{1x} + \frac{B}{2} \tan \beta \right)^2 \\
 P_{21} &= \frac{1}{2} K_{h2} \left(H_{1x} - \frac{B}{2} \tan \beta \right)^2 \\
 P_{12} &= \frac{1}{2} K_{h1} H \left(H_{1x} + \frac{B}{2} \tan \beta \right) \\
 P_{22} &= \frac{1}{2} K_{h2} H \left(H_{1x} - \frac{B}{2} \tan \beta \right) \\
 P_{13} &= \frac{1}{2} K_{h1} H \left(H + H_{1x} + \frac{B}{2} \tan \beta \right) \\
 P_{23} &= \frac{1}{2} K_{h2} H \left(H + H_{1x} - \frac{B}{2} \tan \beta \right)
 \end{aligned} \tag{C12.6.2.2.5-2}$$

When the pressures are substituted into Eq. C12.6.2.2.5-1, the following results:

$$E(x) = A_2 x^2 + A_1 x + A_0 \tag{C12.6.2.2.5-3}$$

in which:

$$\begin{aligned}
 A_2 &= \frac{1}{2} \left(\frac{H_{1L}}{L} \right)^2 (K_{h1} - K_{h2}) \\
 A_1 &= \frac{1}{2} \left(\frac{H_{1L}}{L} \right) [B(K_{h1} + K_{h2}) \tan \beta + H(K_{h1} - K_{h2})] \\
 A_0 &= \frac{1}{24} [(3B^2 \tan^2 \beta + 4H^2)(K_{h1} - K_{h2}) \\
 &\quad + 6HB(K_{h1} + K_{h2}) \tan \beta]
 \end{aligned} \tag{C12.6.2.2.5-4}$$

The support forces for the unbalanced distribution load, $E(x)$, are:

$$\begin{aligned}
 F &= \frac{1}{6} L \sec \alpha (2A_2 L^2 + 3A_1 L + 6A_0) \\
 S_1 &= -\frac{1}{12} \frac{L}{B} [A_2 L^2 (3L - 2B \tan \alpha) + A_1 L (4L \\
 &\quad - 3B \tan \alpha) + 6A_0 (L - B \tan \alpha)] \\
 S_2 &= \frac{1}{12} \frac{L}{B} [A_2 L^2 (3L + 2B \tan \alpha) + A_1 L (4L \\
 &\quad + 3B \tan \alpha) + 6A_0 (L + B \tan \alpha)]
 \end{aligned} \tag{C12.6.2.2.5-5}$$

For values of K_h , see Figure C12.6.2.2.5-2.

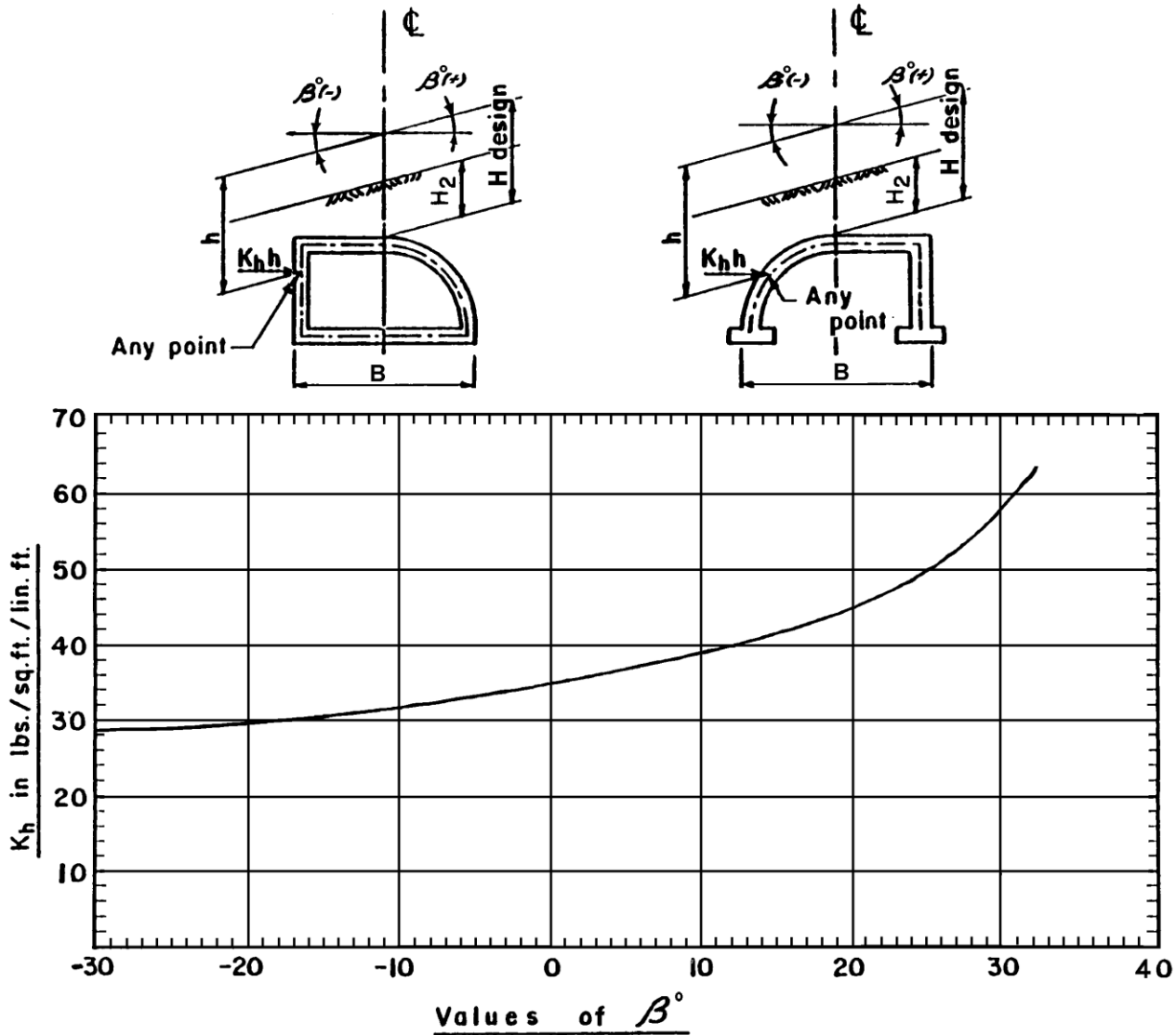

Figure C12.6.2.2.5-2—Lateral Earth Pressure as a Function of Ground Slope

12.6.2.3—Uplift

Uplift shall be considered where structures are installed below the highest anticipated groundwater level.

C12.6.2.3

To satisfy this provision, the dead load on the crown of the structure should exceed the buoyancy of the culvert, using load factors as appropriate.

12.6.3—Safety against Soil Failure

12.6.3.1—Bearing Resistance and Stability

Pipe structures and footings for buried structures shall be investigated for bearing capacity failure and erosion of soil backfill by hydraulic gradients.

12.6.3.2—Corner Backfill for Metal Pipe Arches

The corner backfill for metal pipe arches shall be designed to account for corner pressure taken as the arch thrust divided by the radius of the pipe-arch corner. The soil envelope around the corners of pipe arches shall resist this pressure. Placement of select structural backfill compacted to unit weights higher than normal may be specified.

12.6.4—Hydraulic Design

Design criteria, as specified in Article 2.6 and “Hydraulic Design of Highway Culverts,” FHWA (1985), for hydraulic design considerations shall apply.

12.6.5—Scour

Buried structures shall be designed so that no movement of any part of the structure will occur as a result of scour.

In areas where scour is a concern, the wingwalls shall be extended far enough from the structure to protect the structural portion of the soil envelope surrounding the structure. For structures placed over erodible deposits, a cut-off wall or scour curtain, extending below the maximum anticipated depth of scour or a paved invert, shall be used. The footings of structures shall be placed not less than 2.0 ft below the maximum anticipated depth of scour.

12.6.6—Soil Envelope

12.6.6.1—Trench Installations

The minimum trench width shall provide sufficient space between the pipe and the trench wall to ensure sufficient working room to properly and safely place and compact backfill material.

The contract documents shall require that stability of the trench be ensured by either sloping the trench walls or providing support of steeper trench walls in conformance with OSHA or other regulatory requirements.

12.6.6.2—Embankment Installations

The minimum width of the soil envelope shall be sufficient to ensure lateral restraint for the buried structure. The combined width of the soil envelope and embankment beyond shall be adequate to support all the loads on the culvert and to comply with the movement requirements specified in Article 12.6.2.

C12.6.6.1

As a guide, the minimum trench width should not be less than the greater of the pipe diameter plus 16.0 in. or the pipe diameter times 1.5 plus 12.0 in. The use of specially designed equipment may enable satisfactory installation and embedment even in narrower trenches. If the use of such equipment provides an installation meeting the requirements of this Article, narrower trench widths may be used as approved by the Engineer.

For trenches excavated in rock or high-bearing soils, decreased trench widths may be used up to the limits required for compaction. For these conditions, the use of a flowable backfill material, as specified in Article 12.4.1.3, allows the envelope to be decreased to within 6.0 in. along each side of the pipe.

C12.6.6.2

As a guide, the minimum width of the soil envelope on each side of the buried structure should not be less than the widths specified in Table C12.6.6.2-1:

Table C12.6.6.2-1—Minimum Width of Soil Envelope

Diameter, S (in.)	Minimum Envelope Width (ft)
<24	$S/12$
24–144	2.0
>144	5.0

12.6.6.3—Minimum Cover

The minimum cover, including a well-compacted granular subbase and base course, shall not be less than that specified in Table 12.6.6.3-1, where:

- S = diameter of pipe (in.)
- B_c = outside diameter or width of the structure (ft)
- B'_c = out-to-out vertical rise of pipe (ft)
- ID = inside diameter (in.)

C12.6.6.3

McGrath et al. (2005) has shown that the significant thermal expansion in thermoplastic pipe can affect pavement performance under shallow fills. Depending on the pipe material and the pavement type above it, the minimum cover may include the pavement thickness and base course, along with the sub-base.

Minimum Cover Orientation

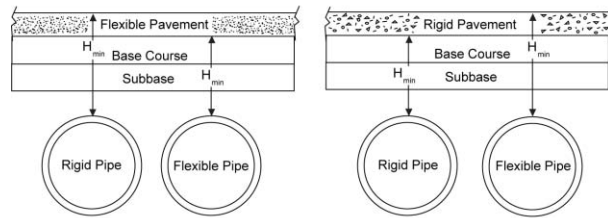

H_{min} = minimum allowable cover dimension

Note: The minimum cover dimension is not to be confused with the fill height used for calculation purposes, which shall be from the top of the pipe to the top of the surface, regardless of the pipe type or pavement type.

If the minimum cover provided in Table 12.6.6.3-1 is not sufficient to avoid placement of the pipe within the pavement layer, then the minimum cover should be increased to a minimum of the pavement thickness, unless an analysis is performed to determine the effect on both the pipe and the pavement.

Table 12.6.6.3-1—Minimum Cover

Type	Condition	Minimum Cover*
Corrugated Metal Pipe		$S/8 \geq 12.0$ in.
Spiral Rib Metal Pipe	Steel Conduit	$S/4 \geq 12.0$ in.
	Aluminum Conduit where $S \leq 48.0$ in.	$S/2 \geq 12.0$ in.
	Aluminum Conduit where $S > 48.0$ in.	$S/2.75 \geq 24.0$ in.
Structural Plate Pipe Structures	—	$S/8 \geq 12.0$ in.
Long-Span Structural Plate Pipe Structures	—	Refer to Table 12.8.3.1.1-1
Structural Plate Box Structures	—	1.4 ft. as specified in Article 12.9.1
Deep Corrugated Structural Plate Structures	—	See Article 12.8.9.4
Thermoplastic Pipe	Under unpaved areas	$ID/8 \geq 12.0$ in.
	Under paved roads	$ID/2 \geq 24.0$ in.
* Minimum cover taken from top of rigid pavement or bottom of flexible pavement		
Type	Condition	Minimum Cover
Reinforced Concrete Pipe	Under unpaved areas or top of flexible pavement	$B_c/8$ or $B'_c/8$, whichever is greater, ≥ 12.0 in.
Type	Condition	Minimum Cover
Reinforced Concrete Pipe	Under bottom of rigid pavement	9.0 in.

If soil cover is not provided, the top of precast or cast-in-place reinforced concrete box structures shall be designed for direct application of vehicular loads.

Additional cover requirements during construction shall be taken as specified in Article 30.5.5 of the *AASHTO LRFD Bridge Construction Specifications*.

12.6.7—Minimum Spacing between Multiple Lines of Pipe

The spacing between multiple lines of pipe shall be sufficient to permit the proper placement and compaction of backfill below the haunch and between the structures.

Contract documents should require that backfilling be coordinated to minimize unbalanced loading between multiple, closely spaced structures. Backfill should be kept level over the series of structures when possible. The effects of significant roadway grades across a series of structures shall be investigated for the stability of flexible structures subjected to unbalanced loading.

C12.6.7

As a guide, the minimum spacing between pipes should not be less than that shown in Table C12.6.7-1.

Table C12.6.7-1—Minimum Pipe Spacing

Type of Structure	Minimum Distance Between Pipes (ft)	
Round Pipes Diameter, D (ft)	<2.0	1.0
	2.0–6.0	$D/2$
	>6.0	3.0
Pipe Arches Span, S (ft)	<3.0	1.0
	3.0–9.0	$S/3$
	9.0–16.0	3.0
Arches Span, S (ft)		
	All Spans	2.0

The minimum spacing can be reduced if a flowable backfill material, as specified in Article 12.4.1.3, is placed between the structures.

12.6.8—End Treatment

12.6.8.1—General

Protection of end slopes shall be given special consideration where backwater conditions occur or where erosion or uplift could be expected. Traffic safety treatments, such as a structurally adequate grating that conforms to the embankment slope, extension of the culvert length beyond the point of hazard, or provision of guide rail, should be considered.

12.6.8.2—Flexible Culverts Constructed on Skew

The end treatment of flexible culverts skewed to the roadway alignment and extending through embankment fill shall be warped to ensure symmetrical loading along either side of the pipe or the headwall shall be designed to support the full thrust force of the cut end.

C12.6.8.1

Culvert ends may represent a major traffic hazard.

When backwater conditions occur, pressure flow at the outlet end of culverts can result in uplift of pipe sections having inadequate cover and scour of erosive soils due to high water flow velocities. Measures to control these problems include anchoring the pipe end in a concrete headwall or burying it in riprap having sufficient mass to resist uplift forces as well as lining outlet areas with riprap or concrete to prevent scour.

C12.6.8.2

For flexible structures, additional reinforcement of the end is recommended to secure the metal edges at inlet and outlet against hydraulic forces. Reinforcement methods include reinforced concrete or structural steel collars, tension tiebacks or anchors in soil, partial headwalls, and cut-off walls below invert elevation.

As a guide in Figure C12.6.8.2-1, limits are suggested for skews to embankments unless the embankment is warped. It also shows examples of warping an embankment cross-section to achieve a square-ended pipe for single and multiple flexible pipe installations where the minimum width of the warped embankment, d' , is taken as 1.50 times the sum of the rise of the culvert and the cover or three times the span of the culvert, whichever is less.

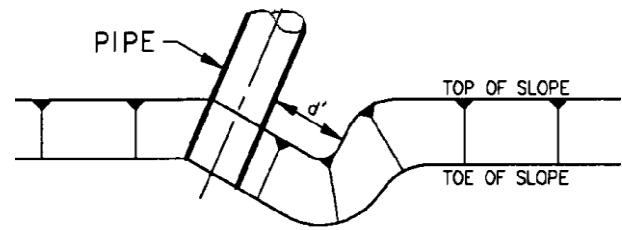

PROPER BALANCE FOR
SINGLE STRUCTURE

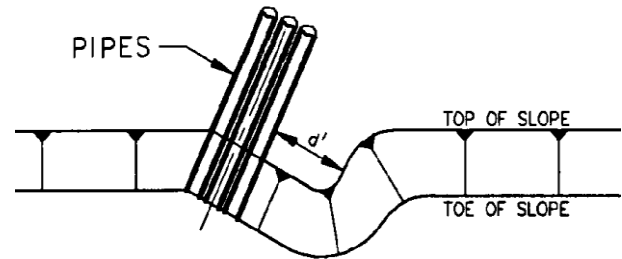

PROPER BALANCE FOR
MULTIPLE STRUCTURE

Figure C12.6.8.2-1—End Treatment of Skewed Flexible Culvert

12.6.9—Corrosive and Abrasive Conditions

The degradation of structural resistance due to corrosion and abrasion shall be considered.

If the design of a metal or thermoplastic culvert is controlled by flexibility factors during installation, the requirements for corrosion and/or abrasion protection may be reduced or eliminated, provided that it is demonstrated that the degraded culvert will provide adequate resistance to loads throughout the service life of the structure.

C12.6.9

Several long-term tests of the field performance of buried structures have resulted in development of empirical guidelines for estimating the effects of corrosion and abrasion. A representative listing includes Bellair and Ewing (1984), Koepf and Ryan (1986), Hurd (1984), Meacham et al. (1982), Potter (1988), *NCHRP Synthesis No. 50* (1978), and Funahashi and Bushman (1991).

For highly abrasive conditions, a special design may be required. Protective coatings may be shop- or field-applied in accordance with AASHTO M 190, M 224, M 243, and M 245 (ASTM A762).

12.7—METAL PIPE, PIPE ARCH, AND ARCH STRUCTURES

12.7.1—General

The provisions herein shall apply to the design of buried corrugated and spiral rib metal pipe and structural plate pipe structures.

Corrugated metal pipe and pipe-arches may be of riveted, welded, or lockseam fabrication with annular or helical corrugations. Structural plate pipe, pipe-arches, and arches shall be bolted with annular corrugations only.

The rise-to-span ratio of structural plate arches shall not be less than 0.3.

The provisions of Article 12.8 shall apply to structures with a radius exceeding 13.0 ft.

12.7.2—Safety against Structural Failure

Corrugated and spiral rib metal pipe and pipe arches and structural plate pipe shall be investigated at the strength limit state for:

- Wall area of pipe,
- Buckling strength, and
- Seam resistance for structures with longitudinal seams.

12.7.2.1—Section Properties

Dimensions and properties of pipe cross-sections; minimum seam strength; mechanical and chemical requirements for aluminum corrugated and steel corrugated pipe and pipe-arch sections; and aluminum and steel corrugated structural plate pipe, pipe-arch, and arch sections, may be taken as given in Appendix A12.

12.7.2.2—Thrust

The factored thrust, T_L , per unit length of wall shall be taken as:

$$T_L = P_F \left(\frac{S}{24} \right) \quad (12.7.2.2-1)$$

where:

- T_L = factored thrust per unit length (kip/ft)
 S = pipe span (in.)
 P_F = factored vertical crown pressure due to earth and live loads (ksf)

C12.7.1

These structures become part of a composite system comprised of the metal pipe section and the soil envelope, both of which contribute to the structural behavior of the system.

For information regarding the manufacture of structures and structural components referred to herein, AASHTO M 196 (ASTM B745) for aluminum, M 36 (ASTM A760) for steel corrugated metal pipe and pipe-arches, and M 167M/M 167 (ASTM A761/A761M) for steel and M 219 (ASTM B746) for aluminum structural plate pipe may be consulted.

C12.7.2.2

Factored vertical crown pressure is calculated as the factored free-field soil pressure at the elevation of the top of the structure, plus the factored live load pressure distributed through the soil cover to the top of the structure.

12.7.2.3—Wall Resistance

The factored axial resistance, R_n , per unit length of wall, without consideration of buckling, shall be taken as:

$$R_n = \phi F_y A \quad (12.7.2.3-1)$$

where:

- A = wall area (in.²/ft)
 F_y = yield strength of metal (ksi)
 ϕ = resistance factor as specified in Article 12.5.5

12.7.2.4—Resistance to Buckling

The wall area, calculated using Eq. 12.7.2.3-1, shall be investigated for buckling. If $f_{cr} < F_y$, A shall be recalculated using f_{cr} in lieu of F_y .

$$\text{If } S < \left(\frac{r}{k}\right) \sqrt{\frac{24E_m}{F_u}}, \text{ then } f_{cr} = F_u - \frac{\left(\frac{F_u k S}{r}\right)^2}{48E_m} \quad (12.7.2.4-1)$$

$$\text{If } S > \left(\frac{r}{k}\right) \sqrt{\frac{24E_m}{F_u}}, \text{ then } f_{cr} = \frac{12E_m}{\left(\frac{kS}{r}\right)^2} \quad (12.7.2.4-2)$$

where:

- S = diameter of pipe or span of plate structure (in.)
 E_m = modulus of elasticity of metal (ksi)
 F_u = tensile strength of metal (ksi)
 f_{cr} = critical buckling stress (ksi)
 r = radius of gyration of corrugation (in.)
 k = soil stiffness factor taken as 0.22

12.7.2.5—Seam Resistance

For pipe fabricated with longitudinal seams, the factored resistance of the seam shall be sufficient to develop the factored thrust in the pipe wall, T_L .

12.7.2.6—Handling and Installation Requirements

Handling flexibility shall be indicated by a flexibility factor determined as:

$$FF = \frac{S^2}{E_m I} \quad (12.7.2.6-1)$$

C12.7.2.4

The use of 0.22 for the soil stiffness is thought to be conservative for the types of backfill material allowed for pipe and arch structures. This lower bound on soil stiffness has a long history of use in previous editions of the Standard Specifications.

C12.7.2.6

Transverse stiffeners may be used to assist corrugated structural plate structures to meet flexibility factor requirements.

Values of the flexibility factors for handling and installation shall not exceed the values for steel and aluminum pipe and plate pipe structures as specified in Article 12.5.6.

12.7.3—Smooth Lined Pipe

Corrugated metal pipe composed of a smooth liner and corrugated shell attached integrally at helical seams, spaced not more than 30.0 in. apart, may be designed on the same basis as a standard corrugated metal pipe having the same corrugations as the shell and a weight per ft not less than the sum of the weights per ft of liner and helically corrugated shell.

The pitch of corrugations shall not exceed 3.0 in., and the thickness of the shell shall not be less than 60 percent of the total thickness of the equivalent standard pipe.

12.7.4—Stiffening Elements for Structural Plate Structures

The stiffness and flexural resistance of structural plate structures may be increased by adding circumferential stiffening elements to the crown. Stiffening elements shall be symmetrical and shall span from a point below the quarter-point on one side of the structure, across the crown, and to the corresponding point on the opposite side of the structure.

12.7.5—Construction and Installation

The contract documents shall require that construction and installation conform to Section 26, *AASHTO LRFD Bridge Construction Specifications*.

12.8—LONG-SPAN STRUCTURAL PLATE STRUCTURES

12.8.1—General

The provisions herein and in Article 12.7 shall apply to the structural design of buried long-span structural plate corrugated metal structures.

The following shapes, illustrated in Figure 12.8.1-1, shall be considered long-span structural plate structures:

- Structural plate pipe and arch shape structures that require the use of special features specified in Article 12.8.3.5, and
- Special shapes of any size having a radius of curvature greater than 13.0 ft in the crown or side plates. Metal box culverts are not considered long-span structures and are covered in Article 12.9.

C12.7.4

Acceptable stiffening elements are:

- Continuous longitudinal structural stiffeners connected to the corrugated plates at each side of the top arc: metal or reinforced concrete, either singly or in combination; and
- Reinforcing ribs formed from structural shapes, curved to conform to the curvature of the plates, fastened to the structure to ensure integral action with the corrugated plates, and spaced at such intervals as necessary.

C12.8.1

These structures become part of a composite system comprised of the metal structure section and the soil envelope, both of which contribute to the behavior of the system.

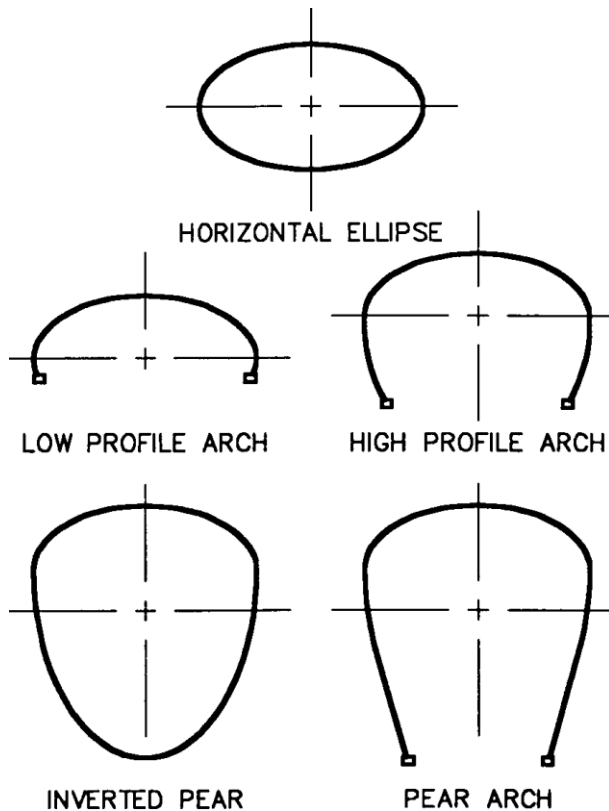

Figure 12.8.1-1—Long-Span Shapes

12.8.2—Service Limit State

No service limit state criteria need be required.

12.8.3—Safety against Structural Failure

With the exception of the requirements for buckling and flexibility, the provisions of Article 12.7 shall apply, except as described herein.

Dimensions and properties of structure cross-sections, minimum seam strength, mechanical and chemical requirements, and bolt properties for long-span structural plate sections shall be taken as specified in Appendix A12 or as described herein.

12.8.3.1—Section Properties

12.8.3.1.1—Cross-Section

The provisions of Article 12.7 shall apply, except as specified.

Structures not described herein shall be regarded as special designs.

C12.8.2

Soil design and placement requirements for long-span structures are intended to limit structure deflections. The contract documents should require that construction procedures be monitored to ensure that severe deformations do not occur during backfill placement and compaction.

C12.8.3

Most long-span culverts are designed for a larger load factor; however, the limit states of flexure and buckling are ignored for those structures. Considering these limit states reduces the uncertainty in the final design and permits use of a lower load factor. This is the same approach used for metal box culverts.

C12.8.3.1.1

Table A12-3 shall apply. Minimum requirements for section properties shall be taken as specified in Table 12.8.3.1.1-1. Covers that are less than that shown in Table 12.8.3.1-1 and that correspond to the minimum plate thickness for a given radius may be used if ribs are used to stiffen the plate. If ribs are used, the plate thickness may not be reduced below the minimum shown for that radius, and the moment of inertia of the rib and plate section shall not be less than that of the thicker unstiffened plate corresponding to the fill height. Use of soil cover less than the minimum values shown for a given radius shall require a special design.

Sharp radii generate high soil pressures. Avoid high ratios when significant heights of fill are involved.

Design not covered in Table 12.8.3.1.1-1 should not be permitted unless substantiated by documentation acceptable to the Owner.

Table 12.8.3.1.1-1—Minimum Requirements for Long-Span Structures with Acceptable Special Features

Top Arc Minimum Thickness (in.)					
Top Radius (ft)	≤15.0	15.0–17.0	17.0–20.0	20.0–23.0	23.0–25.0
6" × 2" Corrugated Steel Plate—Top Arc Minimum Thickness (in.)	0.111	0.140	0.170	0.218	0.249
Geometric Limits					
The following geometric limits shall apply:					
<ul style="list-style-type: none"> • Maximum plate radius—25.0 ft • Maximum central angle of top arc—80.0° • Minimum ratio, top arc radius to side arc radius—2 • Maximum ratio, top arc radius to side arc radius—5 					
Minimum Cover (ft)					
Top Radius (ft)	≤ 15.0	15.0–17.0	17.0–20.0	20.0–23.0	23.0–25.0
Steel thickness without ribs (in.)					
0.111	2.5	—	—	—	—
0.140	2.5	3.0	—	—	—
0.170	2.5	3.0	3.0	—	—
0.188	2.5	3.0	3.0	—	—
0.218	2.0	2.5	2.5	3.0	—
0.249	2.0	2.0	2.5	3.0	4.0
0.280	2.0	2.0	2.5	3.0	4.0

12.8.3.1.2—Shape Control

The requirements of Articles 12.7.2.4 and 12.7.2.6 shall not apply for the design of long-span structural plate structures.

12.8.3.1.3—Mechanical and Chemical Requirements

Tables A12-3, A12-8, and A12-10 shall apply.

12.8.3.2—Thrust

The factored thrust in the wall shall be determined by Eq. 12.7.2.2-1, except the value of S in the Equation shall be replaced by twice the value of the top arc radius, R_T .

12.8.3.3—Wall Area

The provisions of Article 12.7.2.3 shall apply.

12.8.3.4—Seam Strength

The provisions of Article 12.7.2.5 shall apply.

12.8.3.5—Acceptable Special Features*12.8.3.5.1—Continuous Longitudinal Stiffeners*

Continuous longitudinal stiffeners shall be connected to the corrugated plates at each side of the top arc. Stiffeners may be metal or reinforced concrete either singly or in combination.

12.8.3.5.2—Reinforcing Ribs

Reinforcing ribs formed from structural shapes may be used to stiffen plate structures. Where used, they should be:

- Curved to conform to the curvature of the plates,
- Fastened to the structure as required to ensure integral action with the corrugated plates, and
- Spaced at such intervals as necessary to increase the moment of inertia of the section to that required for design.

**12.8.4—Safety against Structural Failure—
Foundation Design****12.8.4.1—Settlement Limits**

A geotechnical survey of the site shall be made to determine that site conditions will satisfy the requirement that both the structure and the critical backfill zone on each side of the structure be properly supported. Design shall satisfy the requirements of Article 12.6.2.2, with the following factors to be considered when establishing settlement criteria:

- Once the structure has been backfilled over the crown, settlements of the supporting backfill relative to the structure must be limited to control dragdown forces. If the sidefill will settle more than the structure, a detailed analysis may be required.
- Settlements along the longitudinal centerline of arch structures must be limited to maintain slope and preclude footing cracks in arches.

C12.8.4.1

Once the top arc of the structure has been backfilled, dragdown forces may occur if the structure backfill settles into the foundation more than the structure. This results in the structure carrying more soil load than the overburden directly above it. If undertaken prior to erecting the structure, site improvements such as surcharging, foundation compacting, etc., often adequately correct these conditions.

Calculated differential settlements across the structure taken from springline-to-springline, Δ , shall satisfy:

$$\Delta \leq \frac{0.01S^2}{R} \tag{12.8.4.1-1}$$

where:

- S = span of structure between springlines of long-span structural plate structures (ft)
- R = rise of structure (ft)

More restrictive settlement limits may be required where needed to protect pavements or to limit longitudinal differential deflections.

Where the structure will settle uniformly with the adjacent soils, long-spans with full inverts can be built on a camber to achieve a proper final grade.

For design, differential settlement between the footings taken across the structure is limited to avoid excessive eccentricity. The limit on any settlement-induced rotation of the structure maintains the top arc centerline within one percent of span, as shown in Figure C12.8.4.1-1.

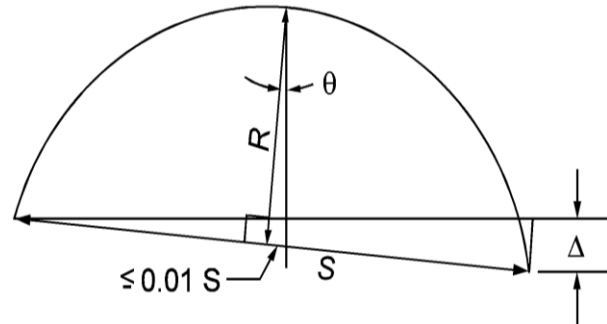

Figure C12.8.4.1-1—Differential Settlement

The rotation of the structure, θ may be determined as:

$$\theta = \tan^{-1} \left(\frac{\Delta}{S} \right) \tag{C12.8.4.1-1}$$

12.8.4.2—Footing Reactions in Arch Structures

Footing reactions may be taken as:

$$R_V = V_{DL} + V_{LL} \cos\Delta \tag{12.8.4.2-1}$$

$$R_H = V_{DL} + V_{LL} \sin\Delta \tag{12.8.4.2-2}$$

in which:

- V_{DL} = $[H_2(S) - A_T] \gamma_s / 2$
- V_{LL} = $n(A_L) / (8 + 2 H_1)$
- n = integer $(2H_1 / L_w + 2) \leq$ number of adjoining traffic lanes

where:

- R_V = vertical footing reaction component (kip/ft)
- R_H = horizontal footing reaction component (kip/ft)
- Δ = return angle of the structure (degrees)
- A_L = axle load (kip), taken as 50 percent of all axle loads that can be placed on the structure at one time, i.e.:

C12.8.4.2

Footing reactions are calculated by simple statics to support the vertical loads. Soil load footing reactions (V_{DL}) are taken as the weight of the fill and pavement above the springline of the structure. Where footings extend out beyond the springline and the foundation has not previously carried the design overburden, this additional soil load (E_v) may need to be added to V_{DL} in an embankment installation.

Live loads that provide relatively limited pressure zones acting on the crown of the structure may be distributed to the footings as indicated in Figure C12.8.4.2-1.

- 32.0 kip for the design truck axle
- 50.0 kip for the design tandem axle pair
- 160.0 kip for E80 railroad loading

A_T = area of the top portion of the structure above the springline (ft²)

H_1 = height of cover above the footing to traffic surface (ft)

H_2 = height of cover from the springline of the structure to traffic surface (ft)

L_w = lane width (ft)

γ_s = unit weight of soil (kcf)

S = span (ft)

The distribution of live load through the fill shall be based on any accepted methods of analysis.

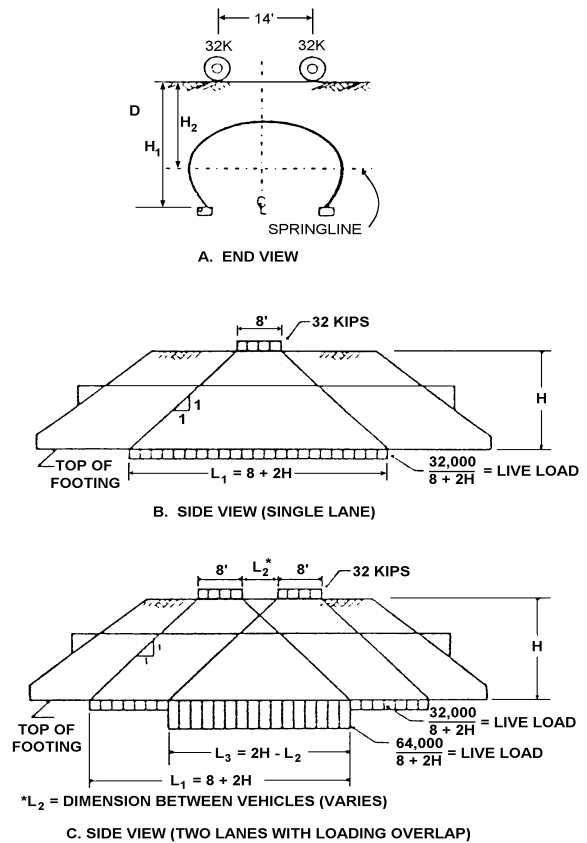

Figure C12.8.4.2-1—Live-Load Footing Reaction Due to Axles of the Design Truck, per Footing

12.8.4.3—Footing Design

Reinforced concrete footings shall be designed in accordance with Article 10.6 and shall be proportioned to satisfy settlement requirements of Article 12.8.4.1.

12.8.5—Safety against Structural Failure—Soil Envelope Design

12.8.5.1—General

Structural backfill material in the envelope around the structure shall satisfy the requirements of Article 12.4.1.3 for long-span structures. The width of the envelope on each side of the structure shall be proportioned to limit shape change during construction activities outside the envelope and to control deflections at the service limit state.

12.8.5.2—Construction Requirements

The structural backfill envelope shall either extend to the trench wall and be compacted against it or extend a distance adequate to protect the shape of the structure from construction loads. The remaining trench width may be filled with suitable backfill material compacted

C12.8.5.1

Structure erection, backfill, and construction shall meet all the requirements of Section 26, *AASHTO LRFD Bridge Construction Specifications*. The performance of the structure depends upon the in-situ embankment or other fill materials beyond the structural backfill. Design must consider the performance of all materials within the zone affected by the structure.

C12.8.5.2

The purpose of this provision is to control shape change from construction activities outside the envelope in trench conditions.

to satisfy the requirements of Article 12.8.5.3. In embankment conditions, the minimum structural backfill width shall be taken as 6.0 ft. Where dissimilar materials not meeting geotechnical filter criteria are used adjacent to each other, a suitable geotextile shall be provided to avoid migration.

12.8.5.3—Service Requirements

The width of the envelope on each side of the structure shall be adequate to limit horizontal compression strain to one percent of the structure's span on each side of the structure.

Determination of the horizontal compressive strain shall be based on an evaluation of the width and quality of the structural backfill material selected as well as the in-situ embankment or other fill materials within the zone on each side of the structure taken to extend to a distance equal to the rise of the structure, plus its cover height as indicated in Figure 12.8.5.3-1.

Forces acting radially off the small radius corner arc of the structure at a distance, d_1 , from the structure may be taken as:

$$P_1 = \frac{T}{R_c + d_1} \quad (12.8.5.3-1)$$

where:

- P_1 = horizontal pressure from the structure at a distance, d_1 (ksf)
- d_1 = distance from the structure (ft)
- T = total dead load and live load thrust in the structure (Article 12.8.3.2) (kip/ft)
- R_c = corner radius of the structure (ft)

The required envelope width adjacent the pipe, d , may be taken as:

$$d = \frac{T}{P_{Brg}} - R_c \quad (12.8.5.3-2)$$

where:

- d = required envelope width adjacent to the structure (ft)
- P_{Brg} = allowable bearing pressure to limit compressive strain in the trench wall or embankment (ksf)

The structural backfill envelope shall be taken to continue above the crown to the lesser of:

- The minimum cover level specified for that structure,
- The bottom of the pavement or granular base course where a base course is present below the pavement, or

C12.8.5.3

The purpose of this provision is to limit deflections under service loads. The limit on soil compression limits the theoretical design increase in span to two percent. This is a design limit, not a performance limit. Any span increase that occurs is principally due to the consolidation of the side support materials as the structure is loaded during backfilling. These are construction movements that attenuate when full cover is reached.

Eqs. 12.8.5.3-1 and 12.8.5.3-2 conservatively assume that the pressure from the structure acts radially outward from the corner arc without further dissipation. Figure C12.8.5.3-1 provides the geometric basis of these Equations.

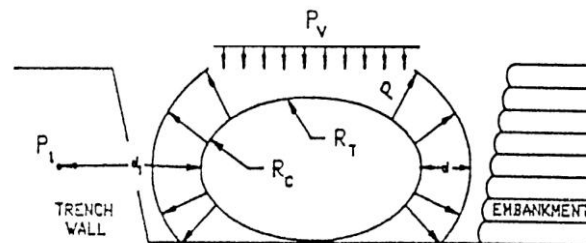

Figure C12.8.5.3-1—Radial Pressure Diagram

- The bottom of any relief slab or similar construction where one is present.

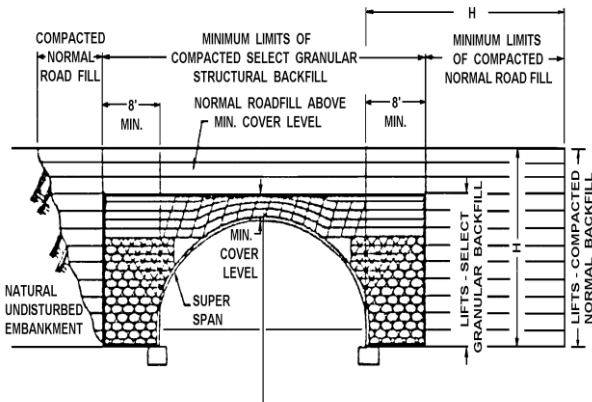

Figure 12.8.5.3-1—Typical Structural Backfill Envelope and Zone of Structure Influence

12.8.6—Safety against Structural Failure—End Treatment Design

12.8.6.1—General

End treatment selection and design shall be considered as an integral part of the structural design.

12.8.6.2—Standard Shell End Types

The standard end types for the corrugated plate shell shall be taken to be those shown in Figure 12.8.6.2-1.

C12.8.6.1

Proper end treatment design ensures proper support of the ends of the structure while providing protection from scour, hydraulic uplift, and loss of backfill due to erosion forces.

C12.8.6.2

Standard end types refer to the way the structural plate structure's ends are cut to match the fill slope, stream banks, etc. While the type of end selected may have aesthetic or hydraulic considerations, the structural design must ensure adequate structural strength and protection from erosion. Hydraulic considerations may require wingwalls, etc.

Step bevel, full bevel, and skewed ends all involve cutting the plates within a ring. Each has its own structural considerations.

The square end is the simplest arrangement. No plates are cut and the barrel retains its integrity.

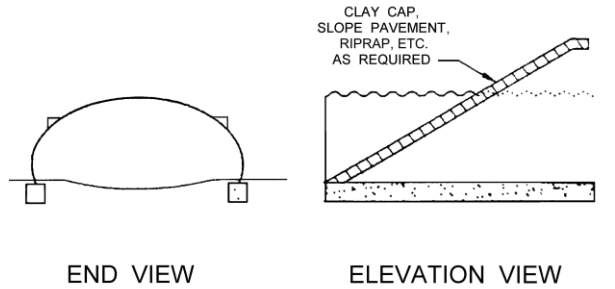

(A) SQUARE END

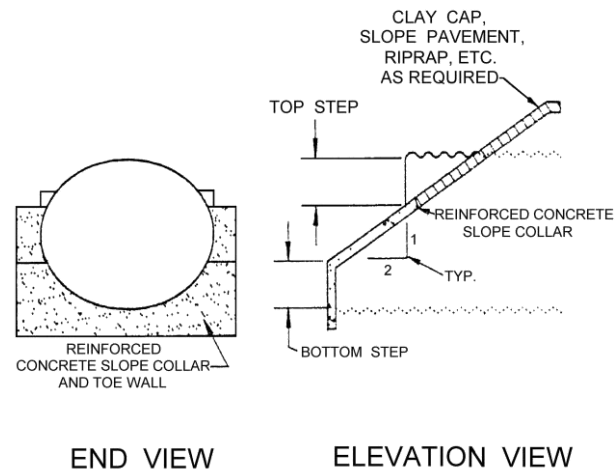

(B) STEP BEVEL

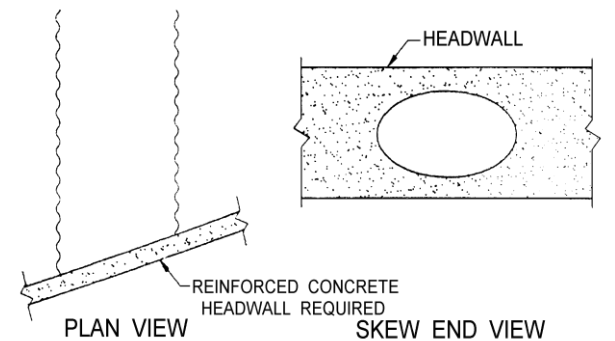

(C) SKEW CUT END
(REQUIRES FULL HEADWALL)

Figure 12.8.6.2-1—Standard Structure End Types

The following considerations shall apply to step bevels:

- The rise of the top step shall be equal to or greater than the rise of the top arc, i.e., plates in the top arc are left uncut.

Step bevels cut the corner (and side on pear and high profile arch shapes) plates on a diagonal (bevel) to match the fill slope.

Step bevels are widely used. The plates in the large radius top arc are left uncut to support the sides of the structure near each end.

- For structures with inverts, the bottom step shall satisfy the requirements for a top step.
- For arches, the bottom step shall be a minimum of 6.0 in. high.
- The slope of the cut plates generally should be no flatter than 3:1.
- The upper edge of the cut plates shall be bolted to and supported by a structural concrete slope collar, slope pavement, or similar device.

Full bevel ends shall be used in special design only. Structures with full inverts shall have a bottom step conforming to the requirements for step bevel ends.

The bevel cut edge of all plates shall be supported by a suitable, rigid concrete slope collar.

Skew cut ends shall be fully connected to and supported by a headwall of reinforced concrete or other rigid construction. The headwall shall extend an adequate distance above the crown of the structure to be capable of reacting the ring compression thrust forces from the cut plates. In addition to normal active earth and live load pressures, the headwall shall be designed to react a component of the radial pressure exerted by the structure as specified in Article 12.8.5.

12.8.6.3—Balanced Support

Designs and details shall provide soil support that is relatively balanced from side-to-side, perpendicularly across the structure. In lieu of a special design, slopes running perpendicularly across the structure shall not exceed ten percent for cover heights of 10.0 ft or less and 15 percent for higher covers.

When a structure is skewed to an embankment, the fill shall be detailed to be warped to maintain balanced support and to provide an adequate width of backfill and embankment soil to support the ends.

12.8.6.4—Hydraulic Protection

12.8.6.4.1—General

In hydraulic applications, provisions shall be made to protect the structure, taken to include the shell, footings, structural backfill envelope, and other fill materials within the zone influenced by the structure.

Invert plates must be left uncut to avoid leaving the invert as triangular shaped elements, when viewed in plan, running upstream and downstream.

Diagonally cut corner and side plates become a retaining wall, supporting the fill slope beside them. They must be provided with suitable, rigid support at the top that acts as a top wale beam and be limited in length. These plates have limited longitudinal strength and inadequate bending strength or fixity to act as a cantilevered retaining wall.

When a full bevel cuts the top plates, additional support is necessary to backfill the structure. Typically, the top step is left in place and field cut only after a suitable rigid concrete slope collar has been poured and adequately cured.

Ring compressive thrust forces act circumferentially around the structure following the corrugations. At the skew cut ends of the plate, these forces act tangentially to the plate and must be resisted by a headwall. Additionally, because a skew cut structure is not perpendicular to the headwall, a portion of the radial pressure from the structure acts normal to the back of the headwall.

C12.8.6.3

Flexible structures have relatively low bending strength. If the earth support is not balanced, the structure in effect becomes a retaining wall. An excessive imbalance causes shape distortion and ultimately failure.

When a structure is skewed to an embankment, two diagonally opposite areas at the ends of the structure are not adequately supported. This must be corrected by extending the embankment an adequate distance out beside the structure.

In lieu of a special design, details provided in Article C12.6.8.2 may be considered.

A properly warped embankment is characterized by equal elevation topographical lines crossing the structure perpendicularly and extending beyond it a suitable distance so that the volume of earth included in the warp provides a gravity retaining wall capable of supporting the radial pressures from the structure with adequate safety.

12.8.6.4.2—Backfill Protection

Design or selection of backfill gradation shall include consideration of loss of backfill integrity due to piping. If materials prone to piping are used, the structure and ends of the backfill envelope shall be adequately sealed to control soil migration and/or infiltration.

12.8.6.4.3—Cut-Off (Toe) Walls

All hydraulic structures with full inverts shall be designed and detailed with upstream and downstream cut-off walls. Invert plates shall be bolted to cut-off walls at a maximum 20.0-in. center-to-center spacing using 0.75-in. bolts.

The cut-off wall shall extend to an adequate depth to limit hydraulic percolation to control uplift forces as specified in Article 12.8.6.4.4 and scour as specified in Article 12.8.6.4.5.

12.8.6.4.4—Hydraulic Uplift

Hydraulic uplift shall be considered for hydraulic structures with full inverts where the design flow level in the pipe can drop quickly. The design shall provide means to limit the resulting hydraulic gradients, with the water level higher in the backfill than in the pipe, so that the invert will not buckle and the structure will not float. Buckling may be evaluated as specified in Article 12.7.2.4, with the span of the structure taken as twice the invert radius.

12.8.6.4.5—Scour

Scour design shall satisfy the requirements of Article 12.6.5. Where erodible soils are encountered, conventional means of scour protection may be employed to satisfy these requirements.

Deep foundations such as piles or caissons should not be used unless a special design is provided to consider differential settlement and the inability of intermittent supports to retain the structural backfill if scour proceeds below the pile cap.

12.8.7—Concrete Relieving Slabs

Concrete relieving slabs may be used to reduce moments in long-span structures.

The length of the concrete relieving slab shall be at least 2.0 ft greater than the span of the structure. The relieving slab shall extend across the width subject to vehicular loading, and its depth shall be determined as specified in Article 12.9.4.6.

C12.8.6.4.2

Backfill piping and migration is always a major consideration in selecting its specific gradation. The ends of the backfill envelope may be sealed using one or a combination of a compacted clay cap, concrete slope pavements, grouted riprap, headwalls to the design storm elevation, and similar details.

C12.8.6.4.4

Structural plate structures are not watertight and allow for both infiltration and exfiltration through the structure's seams, bolt holes, and other discontinuities. Where uplift can be a concern, designs typically employ adequate cut-off walls and other means to seal off water flow into the structural backfill.

C12.8.6.4.5

Structures with full inverts eliminate footing scour considerations when adequate cut-off walls are used. For arches, reinforced concrete invert pavements, riprap, grouted riprap, etc., can be employed to provide scour protection.

C12.8.7

Application of a typical concrete relieving slab is shown in Figure 12.9.4.6-1.

12.8.8—Construction and Installation

The construction documents shall require that construction and installation conform to Section 26 of the *AASHTO LRFD Bridge Construction Specifications*.

12.8.9—Deep Corrugated Structural Plate Structures

12.8.9.1—General

The provisions of this Section shall apply to the structural design of buried, deep corrugated structural plate. These structures are designed as long-span culverts but must also meet provisions for flexure and general buckling. These structures may be manufactured in multiple shapes. Flexibility criteria and special features are not applicable to deep corrugated structures. The rise to span limit of 0.3 in Article 12.7.1 does not apply.

12.8.9.2—Width of Structural Backfill

12.8.9.2.1—Deep Corrugated Structures with Ratio of Crown Radius to Haunch Radius ≤ 5

The structural backfill zone around deep corrugated structures with ratio of crown radius to haunch radius ≤ 5 shall extend to at least the minimum cover height above the crown. At the sides of the structure, the minimum extent of the structural backfill from the outside of the structure springline shall meet one of the following:

- Structure constructed in a trench in which the natural soil is at least as stiff as the engineered soil: 8.0 ft or
- Structure constructed in an embankment or in a trench in which the natural soil is less stiff than the engineered soil: one-third of the structure span but not less than 10.0 ft or more than 17.0 ft.

but not less than required by culvert-soil interaction analysis.

12.8.9.2.2—Deep Corrugated Structures with Ratio of Crown Radius to Haunch Radius > 5

The structural backfill zone around deep corrugated structures with ratio of crown radius to haunch radius > 5 shall extend to at least the minimum cover height above the crown. At the sides of the structure, the minimum extent of structural backfill shall meet one of the following:

C12.8.9.1

The design of long-span metal structures in these Specifications is currently completed with empirical procedures that limit the shapes and plate thicknesses for the structures and require special features. If the provisions are met, then no design is required for flexure or buckling. NCHRP Report 473 recommended updating design provisions for long-span structures and included provisions to allow structures outside the current limits for long-span structures but included limit states for flexure and general buckling. Article 12.8.9 provides a design procedure for such structures. The provisions of Article 12.8.9 apply to structures fabricated from deep corrugated plate, defined in Article 12.2 as corrugated plate with a corrugation depth greater than 5.0 in.

- For structures with spans up to and including 25.0 ft 5.0 in. and less than 5.0 ft of cover: a minimum of 3.5 ft beyond the widest part of the structure or
- For structures with spans up to and including 25.0 ft 5.0 in. and greater than 5.0 ft of cover and for structures with spans greater than 25.0 ft 5.0 in. at all depths of fill: a minimum of one-fifth of the structure span beyond the widest part of the structure but not less than 5.0 ft nor more than 17.0 ft.

but not less than required by culvert-soil interaction analysis.

12.8.9.3—Safety against Structural Failure

Deep corrugated structures shall be designed in accordance with the provisions of Articles 12.8.1 to 12.8.8 except for modified or additional provisions as follow in Article 12.8.9.

12.8.9.3.1—Structural Plate Requirements

Deep corrugated structural plate used to manufacture structures designed under this section shall meet the requirements of AASHTO M 167M/M 167.

Sections may be stiffened. If stiffening is provided by ribs, the ribs shall be bolted to the structural plate corrugation prior to backfilling using a bolt spacing of not more than 16 in. The cross-section properties in Table A12-14 shall apply.

12.8.9.3.2—Structural Analysis

Structures designed under the provisions of this Article shall be analyzed by accepted finite element analysis methods that consider both the strength and stiffness properties of the structural plate and the soil. The analysis shall produce thrust and moments for use in design. The analysis must consider all applicable combinations of construction, earth, live, and other applicable load conditions. Springline thrust due to earth load used in wall resistance, buckling, and seam resistance design shall not be less than 1.3 times the earth load thrust computed in accordance with Article 12.7.2.2.

12.8.9.4—Minimum Depth of Fill

For deep corrugated structural plate structures, the minimum depth of cover (H_D) shall be the smaller of 3.0 ft or the limits for long-span structural plate structures based on top radius and plate thickness in Table 12.8.3.1.1-1. For deep corrugated structures with the ratio of crown radius to haunch radius > 5 , minimum cover shall be 1.5 ft for spans ≤ 25.0 ft 5.0 in. and 2.0 ft for spans > 25.0 ft 5.0 in. The minimum depth of cover in all cases shall not be less than that required by culvert-soil interaction analysis.

C12.8.9.3.1

It is acceptable to measure bolt spacing either at the centroid or crest of the structural plate corrugation.

C12.8.9.3.2

The computer program CANDE was developed by the FHWA specifically for the design of buried culverts and has the necessary soil and culvert material models to complete designs.

Because distribution of live loads to all long-span culverts does not consider arching, application of the 1.3 factor should be limited to just the earth load component of Article 12.7.2.2.

12.8.9.5—Combined Thrust and Moment

The combined effects of moment and thrust at all stages of construction shall meet the following requirement:

$$\left(\frac{T_f}{R_t}\right)^2 + \left|\frac{M_u}{M_n}\right| \leq 1.00 \quad (12.8.9.5-1)$$

where:

- T_f = factored thrust
- R_t = factored thrust resistance = $\phi_t F_y A$
- M_u = factored applied moment
- M_n = factored moment resistance = $\phi_t M_p$
- M_p = plastic moment capacity of section

C12.8.9.5

The equation for combined moment and thrust is taken from the provision for buried structures in the Canadian Highway Bridge Design Code CSA S6 06. The equation is more liberal than the AASHTO equations for combined moment and thrust (axial force) for steel structures in Article 12.8.9.6. However, the provisions in Article 12.8.9.6 are based on strong axis bending of wide flange sections. The equation for combined moment and thrust is taken from the provision for buried structures in the Canadian Highway Bridge Design Code CSA S6 06. The equation is more liberal than the AASHTO equations for combined moment and thrust (axial force) for steel structures in Article 6.9.2.2. However, the provisions in Article 6.9.2.2 are based on strong axis bending of wide flange sections.

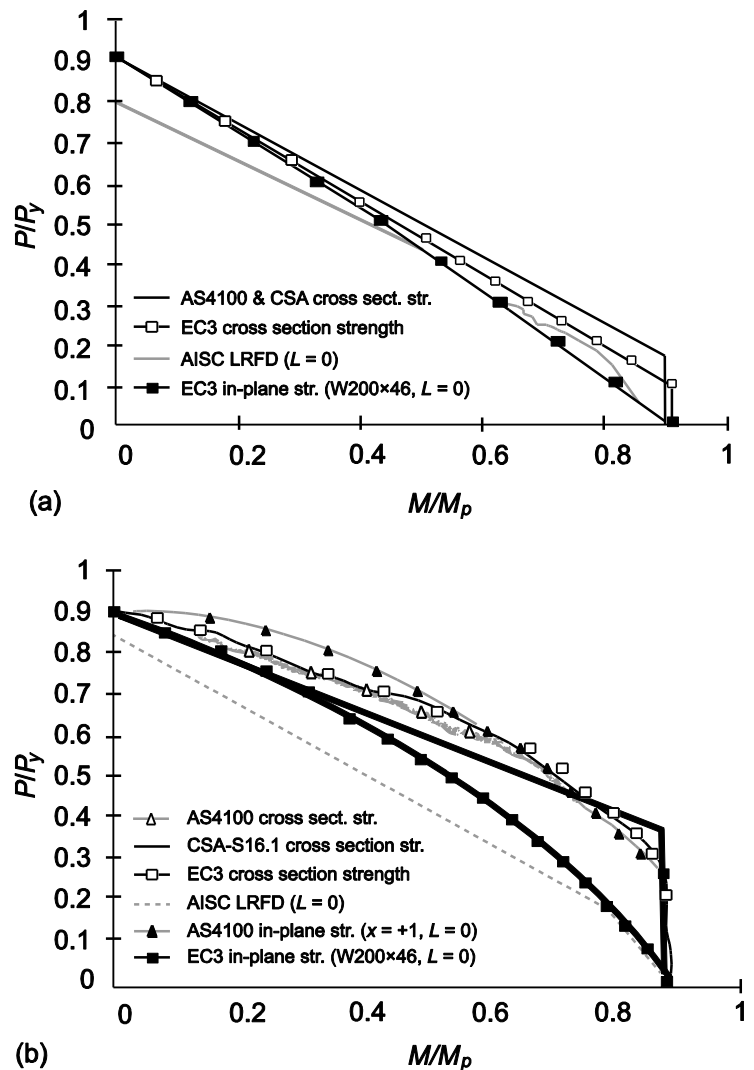

Figure C12.8.9.5-1—Strength Curves for Member of Zero Length: (a) Strong-Axis; (b) Weak-Axis from White and Clark (1997)

12.8.9.6—Global Buckling

The factored thrust in the culvert wall under the final installed condition shall not exceed the nominal resistance to general buckling capacity of the culvert, computed as:

$$R_b = 1.2 \phi_b C_n (E_p I_p)^{\frac{1}{3}} (\phi_s M_s K_b)^{\frac{2}{3}} R_h \quad (12.8.9.6-1)$$

where:

- R_b = nominal axial force in culvert wall to cause general buckling
- ϕ_b = resistance factor for general buckling
- C_n = scalar calibration factor to account for some nonlinear effects = 0.55
- E_p = modulus of elasticity of pipe wall material, (ksi)
- I_p = moment of inertia of stiffened culvert wall per unit length, (in.⁴)
- ϕ_s = resistance factor for soil
- M_s = constrained modulus of embedment (Table 12.12.3.5-1)
- K_b = $(1 - 2\nu) / (1 - \nu^2)$
- ν = Poisson's ratio of soil
- R_h = correction factor for backfill geometry
= $11.4 / (11 + S/H)$
- S = culvert span
- H = depth of fill over top of culvert

12.8.9.7—Connections

The factored moment resistance of longitudinal connections shall be at least equal to the factored applied moment but not less than the greater of:

- 75 percent of the factored moment resistance of the member or
- The average of the factored applied moment and the factored moment resistance of the member.

Moment resistance of connections may be obtained from qualified tests or published standards.

12.9—STRUCTURAL PLATE BOX STRUCTURES**12.9.1—General**

The design method specified herein shall be limited to depth of cover from 1.4 to 5.0 ft.

The provisions of this Article shall apply to the design of structural plate box structures, hereinafter called "metal box culverts." The provisions of Articles 12.7 and 12.8 shall not apply to metal box culvert designs, except as noted.

If rib stiffeners are used to increase the flexural resistance and moment capacity of the plate, the transverse stiffeners shall consist of structural steel or

C12.8.9.6

The proposed buckling equations are taken from the recommendations of NCHRP Report 473, *Recommended Specifications for Large-Span Culverts*.

C12.8.9.7

The *AASHTO LRFD Bridge Construction Specifications* require longitudinal joints to be staggered to avoid a continuous line of bolts on a structure.

C12.9.1

These Specifications are based on three types of data:

- Finite element soil-structure interaction analyses,
- Field loading tests on instrumented structures, and
- Extensive field experience.

These Specifications conform to the same standards as those structures completed since about 1980.

Ribs shall be bolted to the plates to develop the plastic flexural resistance of the composite section. Spacing between ribs shall not exceed 2.0 ft on the crown and 4.5 ft on the haunch. Rib splices shall develop the plastic flexural resistance required at the location of the splice.

reinforced rib plate structures of approximately rectangular shape. They are intended for shallow covers and low wide waterway openings. The shallow covers and extreme shapes of box culverts require special design procedures.

Metal box culverts differ greatly from conventional metal culvert shapes. Metal box culverts are relatively flat at the top and require a large flexural capacity due to extreme geometry and shallow depths of cover of 5.0 ft or less. Analyses over the range of sizes permitted under these Specifications indicate that flexural requirements govern the choice of section in all cases. The effects of thrust are negligible in comparison with those of flexure. This difference in behavior requires a different approach in design.

For information regarding the manufacture of structures and structural components referred to herein, see AASHTO M 167M/M 167 (ASTM A761/A761M) for steel and M 219 (ASTM B746) for aluminum.

12.9.2—Loading

For live loads, the provisions of Article 3.6.1 shall apply.

Unit weights for soil backfill, other than 0.12 kcf, may be considered as specified in Article 12.9.4.2.

C12.9.2

The earth loads for the design procedure described herein are based upon soil backfill having a standard unit weight, γ_s , of 0.12 kcf.

12.9.3—Service Limit State

No service limit state criteria need be applied in the design of box culvert structures.

C12.9.3

Soil design and placement requirements for box culvert structures can limit structure deflections satisfactorily. The contract documents should require that construction procedures be monitored to ensure that severe deformations do not occur during backfill placement and compaction, in which case no deflection limits should be imposed on the completed structure.

12.9.4—Safety against Structural Failure

12.9.4.1—General

The resistance of corrugated box culverts shall be determined at the strength limit state in accordance with Articles 12.5.3, 12.5.4, and 12.5.5 and the requirements specified herein.

Box culvert sections for which these Articles apply are defined in Figure 12.9.4.1-1 and Table 12.9.4.1-1. Table A12-10 shall apply.

C12.9.4.1

Finite element analyses covering the range of metal box culvert shapes described in this Article have shown that flexural requirements govern the design in all cases. Effects of thrust are negligible when combined with flexure.

The structural requirements for metal box culverts are based on the results of finite element analyses and field measurements of in-service box culverts.

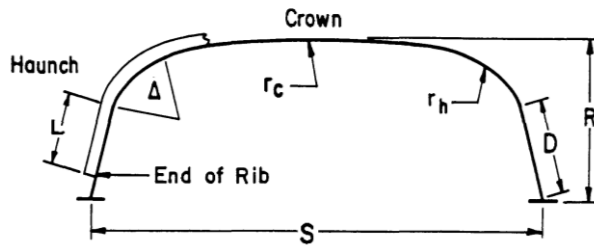

Figure 12.9.4.1-1—Geometry of Box Culverts

Table 12.9.4.1-1—Geometric Requirements for Box Culverts with Spans from 8 ft 9 in. to 25 ft 5 in.

Span, S : 8 ft 9 in. to 25 ft 5 in.
Rise, R : 2 ft 6 in. to 10 ft 6 in.
Radius of crown, $r_c \leq 24$ ft 9 1/2 in.
Radius of haunch, $r_h \geq 2$ ft 6 in.
Haunch radius included angle, Δ : 50° to 70°
Length of leg, D : measured to the bottom of the plate, may vary from 4 3/4 to 71 in.
Minimum length of rib on leg, L , least of 19.0 in., $(D - 3.0)$ in. or to within 3.0 in. of the top of a concrete footing

Table 12.9.4.1-2—Geometric Requirements for Box Culverts with Spans from 25 ft 6 in. to 36 ft 0 in.

Span, S : 25 ft 6 in. to 36 ft 0 in.
Rise, R : 5 ft 7 in. to 14 ft 0 in.
Radius of crown, $r_c \leq 26$ ft 4 in.
Radius of haunch, $r_h \geq 3$ ft 8 in.
Haunch radius included angle, Δ : 48° to 68°
Length of leg, D : measured to the bottom of the plate, may vary from 4 3/4 to 71 in.
Minimum length of rib on leg, L , least of 28.0 in., $(D - 3.0)$ in., or to within 3.0 in. of the top of a concrete footing

The flexural resistance of corrugated plate box structures shall be determined using the specified yield strength of the corrugated plate.

The flexural resistance of plate box structures with ribbed sections shall be determined using specified yield strength values for both rib and corrugated shell. Computed values may be used for design only after confirmation by representative flexural testing. Rib splices shall develop the plastic moment capacity required at the location of the splice.

12.9.4.2—Moments Due to Factored Loads

Unfactored crown and haunch dead and live load moments, M_{dl} and M_{ll} , may be taken as:

For spans ≤ 25 ft 5 in.:

C12.9.4.2

The number of “wheels per notional axle group” determines the value of C_2 in Table 12.9.4.2-1. The following guidelines are consistent with the development of Table 12.9.4.2-1:

$$M_{dl} = \gamma_s S^3 - 0.0053 S - 12 + 0.053 H - 1.4 S^2 \quad (12.9.4.2-1)$$

For spans from 25 ft 6 in. through 36 ft 0 in. with a geometry profile that meets $r_c = 26$ ft, $r_h = 3$ ft 8 7/8 in. and $\Delta = 49.16$ degrees:

$$M_{dl} = \lambda_s \left\{ \begin{array}{l} S^3 [0.00194 - 0.0002 S - 26 H - 1.1] \\ + H - 1.4 [0.053 S^2 + 0.6 S - 26^2] \end{array} \right\} \quad (12.9.4.2-2)$$

$$M_{\ell\ell} = C_{\ell\ell} K_1 \frac{S}{K_2} \quad (12.9.4.2-3)$$

where:

M_{dl} = sum of the nominal crown and haunch dead load moments (kip-ft/ft)

$M_{\ell\ell}$ = sum of the nominal crown and haunch live load moments (kip-ft/ft)

S = box culvert span (ft)

γ_s = soil unit weight (kcf)

H = height of cover from the box culvert rise to top of pavement (ft)

$C_{\ell\ell}$ = adjusted live load
= $C_1 C_2 A_L$ (kip)

A_L = sum of all axle loads in an axle group (kip)

C_1 = 1.0 for single axles and $0.5 + S/50 \leq 1.0$ for tandem axles

C_2 = adjustment factor for number of wheels on a design axle as specified in Table 12.9.4.2-1

in which:

$$K_1 = \frac{0.08}{\left(\frac{H}{S}\right)^{0.2}}, \text{ for } 8 \leq S < 20 \quad (12.9.4.2-4)$$

$$K_1 = \frac{0.08 - 0.002(S - 20)}{\left(\frac{H}{S}\right)^{0.2}}, \text{ for } 20 \leq S \leq 26 \quad (12.9.4.2-5)$$

$$K_2 = 0.54H^2 - 0.4H + 5.05, \text{ for } 1.4 \leq H < 3.0 \quad (12.9.4.2-6)$$

$$K_2 = 1.90H + 3, \text{ for } 3.0 \leq H \leq 5.0 \quad (12.9.4.2-7)$$

- Use “2” as the number of wheels when the design is based on an axle with two wheels, e.g., two 16.0-kip wheels on one 32.0-kip axle.
- Use “4” as the number of wheels where the design is based on either an axle with four wheels, e.g., two 8.0-kip wheels on each end of a 32.0-kip axle; or two axles with two wheels each, e.g., two 12.5-kip wheels on each of two tandem 25.0-kip axles.
- Use “8” as the number of wheels when the design is based on two axles, each with a pair of wheels at each end of each axle.

For spans from 25 ft 6 in. through 36 ft 0 in. with profiles that do not meet the requirements of Eq. 12.9.4.2-2, finite element modeling that employs soil structure interaction may be performed to obtain the nominal crown and haunch moments.

Table 12.9.4.2-1—Adjustment Coefficient Values (C_2) for Number of Wheels per Axle

Wheels per Notional Axle Group	Cover Depth (ft)			
	1.4	2.0	3.0	5.0
2	1.18	1.21	1.24	1.02
4	1.00	1.00	1.00	1.00
8	0.63	0.70	0.82	0.93

Unless otherwise specified, the design truck specified in Article 3.6.1.2.2 should be assumed to have four wheels on an axle. The design tandem specified in Article 3.6.1.2.3 should be assumed to be an axle group consisting of two axles with four wheels on each axle.

The factored moments, M_{dtu} and $M_{\ell tu}$ as referred to in Article 12.9.4.3, shall be determined as specified in Table 3.4.1-1, except that the live load factor used to compute $M_{\ell tu}$ shall be 2.0. The factored reactions shall be determined by factoring the reactions specified in Article 12.9.4.5.

12.9.4.3—Plastic Moment Resistance

The plastic moment resistance of the crown, M_{pc} , and the plastic moment resistance of the haunch, M_{ph} , shall not be less than the proportioned sum of adjusted dead and live load moments. The values of M_{pc} and M_{ph} shall be determined as follows:

$$M_{pc} \geq C_H P_c M_{dtu} + M_{\ell tu} \quad (12.9.4.3-1)$$

$$M_{ph} \geq C_H (1.0 - P_c) M_{dtu} + R_H M_{\ell tu} \quad (12.9.4.3-2)$$

where:

C_H = crown soil cover factor specified in Article 12.9.4.4

P_c = allowable range of the ratio of total moment carried by the crown as specified in Table 12.9.4.3-1

R_H = acceptable values of the haunch moment reduction factor as specified in Table 12.9.4.3-2

M_{dtu} = factored dead load moment as specified in Article 12.9.4.2 (kip-ft)

$M_{\ell tu}$ = factored live load moment as specified in Article 12.9.4.2 (kip-ft)

C12.9.4.3

Some discretion is allowed relative to the total flexural capacity assigned to the crown and haunches of box culverts.

The distribution of moment between the crown and haunch, described in Article C12.9.4.2, is accomplished in the design using the crown moment proportioning factor, P_c , which represents the proportion of the total moment that can be carried by the crown of the box culvert and that varies with the relative flexural capacities of the crown and haunch components.

The requirements given herein can be used to investigate products for compliance with these Specifications. Using the actual crown flexural capacity, M_{pc} , provided by the metal box structure under consideration and the loading requirements of the application, Eq. 12.9.4.3-1 can be solved for the factor P_c , which should fall within the allowable range of Table 12.9.4.3-1. Knowing P_c , Eq. 12.9.4.3-2 can be solved for M_{ph} , which should not exceed the actual haunch flexural resistance provided by the structure section. If Eq. 12.9.4.3-1 indicates a higher value of P_c than permitted by the allowable ranges in Table 12.9.4.3-1, the actual crown is over designed, which is acceptable. However, in this case, only the maximum value of P_c , allowed by Table 12.9.4.3-1, should be used to calculate the required M_{ph} from Eq. 12.9.4.3-2.

Table 12.9.4.3-1—Crown Moment Proportioning Values, P_c for Spans ≤ 25 ft 5 in.

Span (ft)	Allowable Range of P_c
<10.0	0.55–0.70
10.0–15.0	0.50–0.70
15.0–20.0	0.45–0.70
20.0–25.4	0.45–0.60

Table 12.9.4.3-2—Crown Moment Positioning Values, P_c , for Spans from 25 ft 6 in. to 36 ft 0 in.

Depth of Fill (ft)	Allowable Range of P_c
1.4–2.5	0.55–0.65
2.5–4.0	0.45–0.55
4.0–5.0	0.35–0.55

Table 12.9.4.3-3—Haunch Moment Reduction Values, R_H , for Spans ≤ 25 ft 5 in.

	Cover Depth (ft)			
	1.4	2.0	3.0	4.0 to 5.0
R_H	0.66	0.74	0.87	1.00

For spans from 25 ft 6 in. to 36 ft 0 in., $R_H = 1.0$ for all cover depths.

12.9.4.4—Crown Soil Cover Factor, C_H

For depths of soil cover greater than or equal to 3.5 ft, the crown soil cover factor, C_H , shall be taken as 1.0.

For crown cover depth between 1.4 and 3.5 ft, the crown soil cover factor shall be taken as:

$$C_H = 1.15 - \left(\frac{H - 1.4}{14} \right) \quad (12.9.4.4-1)$$

where:

H = depth of cover over crown (ft)

12.9.4.5—Footing Reactions

Reactions at the box culvert footing shall be determined as:

$$V = \gamma_s \left(\frac{HS}{2.0} + \frac{S^2}{40.0} \right) + \frac{A_L}{8 + 2H + R} \quad (12.9.4.5-1)$$

where:

V = unfactored footing reaction (kip/ft)

γ_s = unit weight of backfill (kcf)

H = depth of cover over crown (ft)

R = rise of culvert (ft)

C12.9.4.4

The results of finite element analyses and field monitoring studies to evaluate the effects of load-induced deformations and in-plane deformed geometries indicate that the design moments should be increased where the cover is less than 3.5 ft.

Eq. 12.9.4.4-1 is discussed in Boulanger et al. (1989).

S = span (ft)
 A_L = total axle load (kip)

12.9.4.6—Concrete Relieving Slabs

Relieving slabs may be used to reduce flexural moments in box culverts. Relieving slabs shall not be in contact with the crown as shown in Figure 12.9.4.6-1.

The length of the concrete relieving slab shall be at least 2.0 ft greater than the culvert span and sufficient to project 1.0 ft beyond the haunch on each side of the culvert. The relieving slab shall extend across the width subject to vehicular loading.

The depth of reinforced concrete relieving slabs shall be determined as:

$$t = t_b R_{AL} R_c R_f \quad (12.9.4.6-1)$$

where:

- t = minimum depth of slab (in.)
- t_b = basic slab depth as specified in Table 12.9.4.6-1 (in.)
- R_{AL} = axle load correction factor specified in Table 12.9.4.6-2
- R_c = concrete strength correction factor specified in Table 12.9.4.6-3
- R_f = factor taken as 1.2 for box structures having spans less than 26.0 ft

C12.9.4.6

The box culvert design procedure described herein does not directly incorporate consideration of concrete relieving slabs on the influence of concrete pavement. Therefore, the procedures described in Duncan et al. (1985) should be used instead. At this time, the beneficial effect of a relieving slab can only be determined by refined soil-structure interaction analyses. The provisions given herein are applicable only for box structures having spans under 26.0 ft. The purpose of avoiding contact between the relieving slab and the culvert is to avoid concentration of the load applied through the slab to the crown of the culvert. As little as 1.0- to 3.0-in. clearance is thought to be sufficient to distribute the load.

Where an Owner requires design for an axle other than the standard 32.0-kip axle, the factor R_{AL} may be used to adjust the depth of a concrete relieving slab as specified in Eq. 12.9.4.6-1.

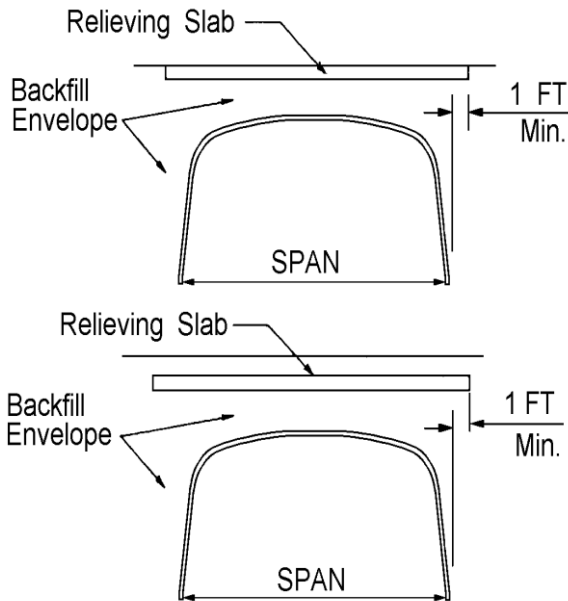

Figure 12.9.4.6-1—Metal Box Culverts with Concrete Relieving Slab

Table 12.9.4.6-1—Basic Slab Depth, t_b (in.) (Duncan et al., 1985)

Unified Classification of Subgrade Beneath Slab	Relative Compaction— % of Standard AASHTO Maximum Dry Unit Weight		
	100	95	90
	Basic Slab Depth (in.)		
GW, GP, SW, SP, or SM	7.5	8.0	8.5
SM-SC or SC	8.0	8.5	9.0
ML or CL	8.5	9.0	9.5

Table 12.9.4.6-2—Axle Load Correction Factor, R_{AL} (Duncan et al., 1985)

Single Axle Load (kip)	R_{AL}
10.0	0.60
20.0	0.80
30.0	0.97
32.0	1.00
40.0	1.05
45.0	1.10
50.0	1.15

Table 12.9.4.6-3—Concrete Strength Correction Factor, R_c (Duncan et al., 1985)

Concrete Compressive Strength, f'_c (ksi)	R_c
3.0	1.19
3.5	1.15
4.0	1.10
4.5	1.05
5.0	1.01
5.5	0.97
6.0	0.94

12.9.5—Construction and Installation

The contract documents shall require that construction and installation conform to Section 26, “Metal Culverts,” *AASHTO LRFD Bridge Construction Specifications*.

12.10—REINFORCED CONCRETE PIPE

12.10.1—General

The provisions herein shall apply to the structural design of buried precast reinforced concrete pipes of circular, elliptical, and arch shapes.

The structural design of the types of pipes indicated above may proceed by either of two methods:

- The direct design method at the strength limit state as specified in Article 12.10.4.2, or
- The indirect design method at the service limit state as specified in Article 12.10.4.3.

C12.10.1

These structures become part of a composite system comprised of the reinforced concrete buried section and the soil envelope.

Standard dimensions for these units are shown in AASHTO M 170 (ASTM C76), M 206M/M 206 (ASTM C506M and C506), M 207M/M 207 (ASTM C507M and C507), and M 242M/M 242 (ASTM C655M and C655).

12.10.2 Loading

12.10.2.1 Standard Installations

The contract documents shall specify that the foundation bedding and backfill comply with the provisions of Article 27.5.2 of the *AASHTO LRFD Construction Specifications*.

Minimum compaction requirements and bedding thickness for standard embankment installations and standard trench installations shall be as specified in Tables 12.10.2.1-1 and 12.10.2.1-2, respectively.

C12.10.2.1

The four standard installations replace the historic bedding classes. A comprehensive soil-structure interaction analysis and design program (SPIDA) was developed and used to perform soil-structure interaction analyses for the various soil and installation parameters encompassed in the provisions. The SPIDA studies used to develop the standard installations were conducted for positive projection embankment conditions to provide conservative results for other embankment and trench conditions. These studies also conservatively assume a hard foundation and bedding existing beneath the invert of the pipe, plus void and/or poorly compacted material in the haunch areas, 15 degrees to 40 degrees each side of the invert, resulting in a load concentration such that calculated moments, thrusts, and shears are increased.

Table 12.10.2.1-1—Standard Embankment Installation Soils and Minimum Compaction Requirements

Installation Type	Bedding Thickness	Haunch and Outer Bedding	Lower Side
Type 1	For soil foundation, use $B_c/2.0$ ft minimum, not less than 3.0 in. For rock foundation, use B_c ft minimum, not less than 6.0 in.	95% SW	90% SW, 95% ML, or 100% CL
Type 2—Installations are available for horizontal elliptical, vertical elliptical, and arch pipe	For soil foundation, use $B_c/2.0$ ft minimum, not less than 3.0 in. For rock foundation, use B_c ft minimum, not less than 6.0 in.	90% SW or 95% ML	85% SW, 90% ML, or 95% CL
Type 3—Installations are available for horizontal elliptical, vertical elliptical, and arch pipe	For soil foundation, use $B_c/2.0$ ft minimum, not less than 3.0 in. For rock foundation, use B_c ft minimum, not less than 6.0 in.	85% SW, 90% ML, or 95% CL	85% SW, 90% ML, or 95% CL
Type 4	For soil foundation, no bedding required. For rock foundation, use $B_c/2.0$ ft minimum, not less than 6.0 in.	No compaction required, except if CL, use 85% CL	No compaction required, except if CL, use 85% CL

The following interpretations apply to Table 12.10.2.1-1:

- Compaction and soil symbols, i.e., “95 percent SW,” shall be taken to refer to SW soil material with a minimum standard proctor compaction of 95 percent. Equivalent modified proctor values shall be as given in Table 27.5.2.2-3 of the *AASHTO LRFD Bridge Construction Specifications*.
- Soil in the outer bedding, haunch, and lower side zones, except within $B_c/3$ from the pipe springline, shall be compacted to at least the same compaction as the majority of soil in the overfill zone.
- The minimum width of a subtrench shall be $1.33B_c$, or wider if required for adequate space to attain the specified compaction in the haunch and bedding zones.
- For subtrenches with walls of natural soil, any portion of the lower side zone in the subtrench wall
- A subtrench is defined as a trench in the natural material under an embankment used to retain bedding material with its top below finished grade by more than ten percent of the depth of soil cover on the top of the culvert or pipe. For roadways, the top of a subtrench is at an elevation lower than

shall be at least as firm as an equivalent soil placed to the compaction requirements specified for the lower side zone and as firm as the majority of soil in the overfill zone. Otherwise, it shall be removed and replaced with soil compacted to the specified level.

1.0 ft below the bottom of the pavement base material.

Table 12.10.2.1-2—Standard Trench Installation Soils and Minimum Compaction Requirements

Installation Type	Bedding Thickness	Haunch and Outer Bedding	Lower Side
Type 1	For soil foundation, use $B_c/2.0$ ft minimum, not less than 3.0 in. For rock foundation, use B_c ft minimum, not less than 6.0 in.	95% SW	90% SW, 95% ML, or 100% CL, or natural soils of equal firmness
Type 2—Installations are available for horizontal elliptical, vertical elliptical, and arch pipe	For soil foundation, use $B_c/2.0$ ft minimum, not less than 3.0 in. For rock foundation, use B_c ft minimum, not less than 6.0 in.	90% SW or 95% ML	85% SW, 90% ML, 95% CL, or natural soils of equal firmness
Type 3—Installations are available for horizontal elliptical, vertical elliptical, and arch pipe	For soil foundation, use $B_c/4.0$ ft minimum, not less than 3.0 in. For rock foundation, use B_c ft minimum, not less than 6.0 in.	85% SW, 90% ML or 95% CL	85% SW, 90% ML, 95% CL, or natural soils of equal firmness
Type 4	For soil foundation, no bedding required. For rock foundation, use B_c ft minimum, not less than 6.0 in.	No compaction required, except if CL, use 85% CL	85% SW, 90% ML, 95% CL, or natural soil of equal firmness

The following interpretations apply to Table 12.10.2.1-2:

- Compaction and soil symbols, i.e., “95 percent SW,” shall be taken to refer to SW soil material with minimum standard proctor compaction of 95 percent. Equivalent modified proctor values shall be as given in Table 27.5.2.2-3 of the *AASHTO LRFD Bridge Construction Specifications*.
- The trench top elevation shall be no lower than $0.1H$ below finish grade; for roadways, its top shall be no lower than an elevation of 1.0 ft below the bottom of the pavement base material.
- Soil in bedding and haunch zones shall be compacted to at least the same compaction as specified for the majority of soil in the backfill zone.
- If required for adequate space to attain the specified compaction in the haunch and bedding zones the trench width shall be wider than that shown in Figures 27.5.2.2-1 and 27.5.2.2-2 of the *AASHTO LRFD Bridge Construction Specifications*.
- For trench walls that are within 10 degrees of vertical, the compaction or firmness of the soil in the trench walls and lower side zone need not be considered.
- For trench walls with greater than 10 degrees slopes that consist of embankment, the lower side shall be compacted to at least the same compaction as specified for the soil in the backfill zone.

The unfactored earth load, W_E , shall be determined as:

$$W_E = F_e w B_c H \tag{12.10.2.1-1}$$

where:

- W_E = unfactored earth load (kip/ft)
- F_e = soil-structure interaction factor for the specified installation as defined herein
- B_c = out-to-out horizontal dimension of pipe (ft)
- H = height of fill over pipe (ft)
- w = unit weight of soil (pcf)

The unit weight of soil used to calculate earth load shall be the estimated unit weight for the soils specified for the pipe soil installation but shall not be taken to be less than 110 lb./ft³.

Standard installations for both embankments and trenches shall be designed for positive projection, embankment loading conditions where F_e shall be taken as the vertical arching factor, VAF , specified in Table 12.10.2.1-3 for each type of standard installation.

For standard installations, the earth pressure distribution shall be the Heger pressure distribution shown in Figure 12.10.2.1-1 and Table 12.10.2.1-3 for each type of standard installation.

The product wB_cH is sometimes referred to as the prism load, PL , the weight of the column of earth over the outside diameter of the pipe.

The earth load for designing pipe using a standard installation is obtained by multiplying the weight of the column of earth above the outside diameter of the pipe by the soil-structure interaction factor, F_e , for the design installation type. F_e accounts for the transfer of some of the overburden soil above the regions at the sides of the pipe because the pipe is more rigid than the soil at the side of the pipe for pipe in embankment and wide trench installations. Because of the difficulty of controlling maximum trench width in the field with the widespread use of trench boxes or sloped walls for construction safety, the potential reduction in earth load for pipe in trenches of moderate to narrow width is not taken into account in the determination of earth load and earth pressure distribution on the pipe. Both trench and embankment installations are to be designed for embankment (positive projecting) loads and pressure distribution in direct design or bedding factors in indirect design.

The earth pressure distribution and lateral earth force for a unit vertical load is the Heger pressure distribution and horizontal arching factor, HAF . The normalized pressure distribution and HAF values were obtained for each standard installation type from the results of soil-structure interaction analyses using SPIDA, together with the minimum soil properties for the soil types and compaction levels specified for the installations.

When nonstandard installations are used, the earth load and pressure distribution should be determined by an appropriate soil-structure interaction analysis.

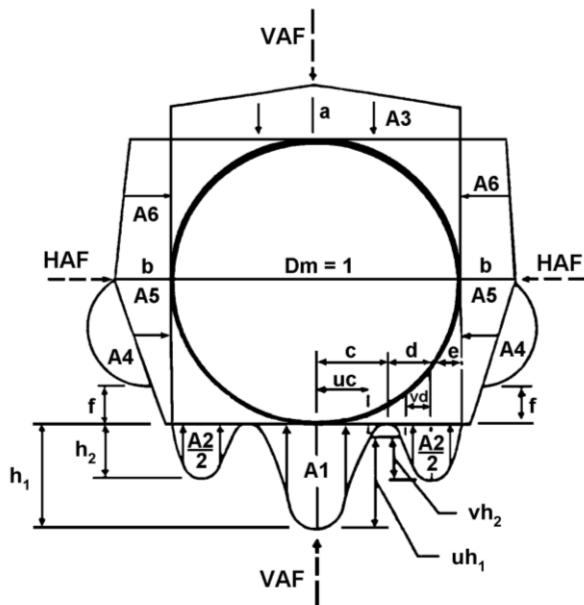

Figure 12.10.2.1-1—Heger Pressure Distribution and Arching Factors

Table 12.10.2.1-3—Coefficients for Use with Figure 12.10.2.1-1

	Installation Type			
	1	2	3	4
<i>VAF</i>	1.35	1.40	1.40	1.45
<i>HAF</i>	0.45	0.40	0.37	0.30
<i>A1</i>	0.62	0.85	1.05	1.45
<i>A2</i>	0.73	0.55	0.35	0.00
<i>A3</i>	1.35	1.40	1.40	1.45
<i>A4</i>	0.19	0.15	0.10	0.00
<i>A5</i>	0.08	0.08	0.10	0.11
<i>A6</i>	0.18	0.17	0.17	0.19
<i>a</i>	1.40	1.45	1.45	1.45
<i>b</i>	0.40	0.40	0.36	0.30
<i>c</i>	0.18	0.19	0.20	0.25
<i>e</i>	0.08	0.10	0.12	0.00
<i>f</i>	0.05	0.05	0.05	—
<i>u</i>	0.80	0.82	0.85	0.90
<i>v</i>	0.80	0.70	0.60	—

The following shall apply to Table 12.10.2.1-3:

- *VAF* and *HAF* are vertical and horizontal arching factors. These coefficients represent nondimensional total vertical and earth loads on the pipe, respectively. The actual total vertical and horizontal loads are $(VAF) \times (PL)$ and $(HAF) \times (PL)$, respectively, where *PL* is the prism load.
- Coefficients *A1* through *A6* represent the integration of nondimensional vertical and horizontal components of soil pressure under the indicated portions of the component pressure diagrams, i.e., the area under the component pressure diagrams.
- The pressures are assumed to vary either parabolically or linearly, as shown in Figure 12.10.2.1-1, with the nondimensional magnitudes at governing points represented by h_1 , h_2 , uh_1 , vh_2 , *a*, and *b*.
- Nondimensional horizontal and vertical dimensions of component pressure regions are defined by *c*, *d*, *e*, *uc*, *vd*, and *f* coefficients,

where:

$$d = 0.5 - c - e \quad (12.10.2.1-2)$$

$$h_1 = 1.5A1 / c \quad (12.10.2.1-3)$$

$$h_2 = 1.5A2 / [d \quad (1+v) + 2e] \quad (12.10.2.1-4)$$

12.10.2.2 Pipe Fluid Weight

The unfactored weight of fluid, W_F , in the pipe shall be considered in design based on a fluid weight of 62.4 lb./ft³, unless otherwise specified. For standard installations, the fluid weight shall be supported by vertical earth pressure that is assumed to have the same distribution over the lower part of the pipe as given in Figure 12.10.2.1-1 for earth load.

12.10.2.3—Live Loads

Live loads shall be as specified in Article 3.6 and shall be distributed through the earth cover as specified in Article 3.6.1.2.6. For standard installations, the live load on the pipe shall be assumed to have a uniform vertical distribution across the top of the pipe and the same distribution across the bottom of the pipe as given in Figure 12.10.2.1-1.

12.10.3—Service Limit State

The width of cracks in the wall shall be investigated at the service limit state for moment and thrust. Generally, the crack width should not exceed 0.01 in.

12.10.4—Safety against Structural Failure

12.10.4.1—General

The resistance of buried reinforced concrete pipe structures against structural failure shall be determined at the strength limit state for:

- Flexure,
- Thrust,
- Shear, and
- Radial tension.

The dimensions of pipe sections shall be determined using either the analytically-based direct design method or the empirically-based indirect design method.

When quadrant mats, stirrups, and/or elliptical cages are specified in the contract documents, the orientation of the pipe installation shall be specified, and the design shall account for the possibility of an angular misorientation of 10 degrees during the pipe installation.

C12.10.4.1

The direct design method uses a pressure distribution on the pipe from applied loads and bedding reactions based on a soil-structure interaction analysis or an elastic approximation. The indirect design method uses empirically-determined bedding factors that relate the total factored earth load to the concentrated loads and reactions applied in three-edge bearing tests.

12.10.4.2—Direct Design Method

12.10.4.2.1—Loads and Pressure Distribution

The total vertical load acting on the pipe shall be determined as specified in Article 12.10.2.1.

The pressure distribution on the pipe from applied loads and bedding reaction shall be determined from either a soil-structure analysis or from a rational approximation, either of which shall permit the development of a pressure diagram, shown schematically in Figure 12.10.4.2.1-1, and the analysis of the pipe.

C12.10.4.2.1

The direct design method was accepted in 1993 by ASCE and is published in ASCE 93-15, *Standard Practice for Direct Design of Buried Precast Concrete Pipe Using Standard Installations* (SIDD). The design method was developed along with the research performed on the standard installations. However, the design equations are applied after the required bending moments, thrusts, and shear forces at all critical sections have been determined using any one of the acceptable pressure distributions. Therefore, the use of the design equations herein is not limited to the standard installations or any one assumed pressure distribution.

Direct design requires:

- The determination of earth loads and live load pressure distributions on the structure for the bedding and installation conditions selected by the Engineer;
- Analysis to determine thrust, moments, and shears; and
- Design to determine circumferential reinforcement.

The procedures for analysis and design are similar to those used for other reinforced concrete structures.

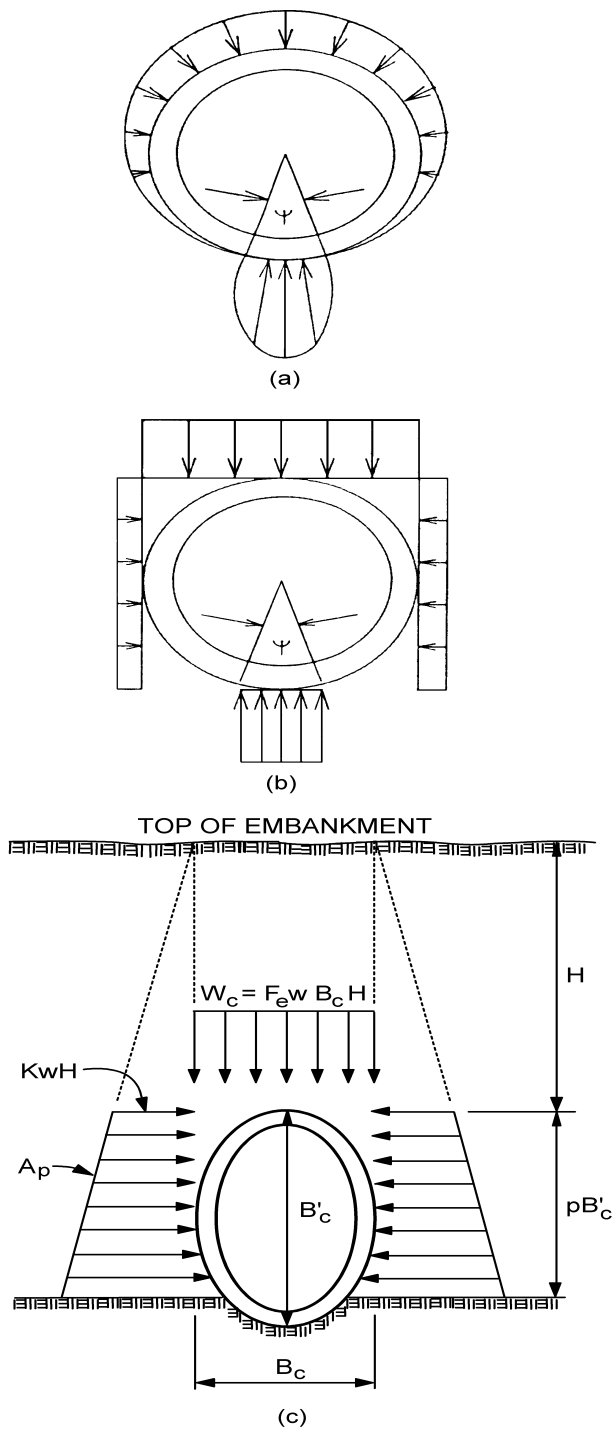

Figure 12.10.4.2.1-1—Suggested Design Pressure Distribution around a Buried Concrete Pipe for Analysis by Direct Design

12.10.4.2.2—Analysis for Force Effects with the Pipe Ring

Force effects in the pipe shall be determined by an elastic analysis of the pipe ring under the assumed pressure distribution or a soil-structure analysis.

12.10.4.2.3—Process and Material Factors

Process and material factors, F_{rp} for radial tension and F_{vp} for shear strength, for design of plant-made reinforced concrete pipe should be taken as 1.0. Higher values of these factors may be used if substantiated by sufficient testing in accordance with AASHTO M 242M/M 242 (ASTM C655M and C655).

12.10.4.2.4—Flexural Resistance at the Strength Limit State

12.10.4.2.4a—Circumferential Reinforcement

C12.10.4.2.4a

Reinforcement for flexural resistance provided in a length, b , usually taken as 12.0 in. shall satisfy:

$$A_s \geq \frac{g\phi d - N_u - \sqrt{g \left[g(\phi d)^2 - N_u(2\phi d - h) - 2M_u \right]}}{f_y} \quad (12.10.4.2.4a-1)$$

in which:

$$g = 0.85bf'_c \quad (12.10.4.2.4a-2)$$

where:

- A_s = area of reinforcement per length of pipe, b (in.²/ft)
- f_y = specified yield strength of reinforcing (ksi)
- d = distance from compression face to centroid of tension reinforcement (in.)
- h = wall thickness of pipe (in.)
- M_u = moment due to factored loads (kip-in./ft)
- N_u = thrust due to factored load, taken to be positive for compression (kip/ft)
- ϕ = resistance factor for flexure specified in Article 12.5.5

The required area of steel, A_s , as determined by Eq. 12.10.4.2.4a-1, should be distributed over a unit length of the pipe, b , which is typically taken as 12.0 in.

The factored actions should also be consistent with the selected unit width.

12.10.4.2.4b—Minimum Reinforcement

The reinforcement, A_s , per ft of pipe shall not be less than:

- For inside face of pipe with two layers of reinforcement:

$$A_s \geq \frac{(S_i + h)^2}{1,000f_y} \geq 0.07 \quad (12.10.4.2.4b-1)$$

- For outside face of pipe with two layers of reinforcement:

$$A_s \geq 0.60 \frac{(S_o + h)^2}{1,000f_y} \geq 0.07 \quad (12.10.4.2.4b-2)$$

- For elliptical reinforcement in circular pipe and for 33.0-in. diameter and smaller pipe with a single cage of reinforcement in the middle third of the pipe wall:

$$A_s \geq 2 \frac{(S_i + h)^2}{1,000 f_y} \geq 0.07 \quad (12.10.4.2.4b-3)$$

where:

- S_i = internal diameter or horizontal span of the pipe (in.)
 h = wall thickness of pipe (in.)
 f_y = yield strength of reinforcement (ksi)

12.10.4.2.4c—Maximum Flexural Reinforcement without Stirrups

The flexural reinforcement per ft of pipe without stirrups shall satisfy:

- For inside steel in radial tension:

$$A_{s \max} \leq \frac{0.506 r_s F_{rp} \sqrt{f'_c} (R_\phi) F_{rt}}{f_y} \quad (12.10.4.2.4c-1)$$

where:

- r_s = radius of the inside reinforcement (in.)
 f'_c = compressive strength of concrete (ksi)
 f_y = specified yield strength of reinforcement (ksi)
 R_ϕ = (ϕ_r/ϕ_f) ; ratio of resistance factors for radial tension and moment specified in Article 12.5.5
 F_{rp} = 1.0 unless a higher value substantiated by test data and approved by the Engineer

in which:

- For 12.0 in. $\leq S_i \leq 72.0$ in.

$$F_{rt} = 1 + 0.00833 (72 - S_i)$$

- For 72.0 in. $< S_i \leq 144.0$ in.:

$$F_{rt} = \frac{(144 - S_i)^2}{26,000} + 0.80$$

- For $S_i > 144.0$ in.:

$$F_{rt} = 0.80$$

- For reinforcing steel in compression:

$$A_{s \max} \leq \frac{\left[\left(\frac{55 g' \phi d}{87 + f_y} \right) - 0.75 N_u \right]}{f_y} \quad (12.10.4.2.4c-2)$$

in which:

$$g' = b f'_c [0.85 - 0.05 (f'_c - 4.0)] \quad (12.10.4.2.4c-3)$$

$$0.85 b f'_c \geq g' \geq 0.65 b f'_c \quad (12.10.4.2.4c-4)$$

where:

b = width of section taken as 12.0 in.

ϕ = resistance factor for flexure as specified in Article 5.5.4.2

12.10.4.2.4d—Reinforcement for Crack Width Control

C12.10.4.2.4d

The crack width factor, F_{cr} , may be determined as:

- If N_s is compressive, it is taken as positive and:

$$F_{cr} = \frac{B_1}{30\phi d A_s} \left[\frac{M_s + N_s \left(d - \frac{h}{2} \right)}{ij} - 0.0316 C_1 b h^2 \sqrt{f'_c} \right] \quad (12.10.4.2.4d-1)$$

- If N_s is tensile, it is taken as negative and:

$$F_{cr} = \frac{B_1}{30 d A_s \phi} [1.1 M_s - 0.6 N_s d - 0.0316 C_1 b h^2 \sqrt{f'_c}] \quad (12.10.4.2.4d-2)$$

in which:

$$j = 0.74 + 0.1 \frac{e}{d} \leq 0.9 \quad (12.10.4.2.4d-3)$$

$$i = \frac{1}{\left(1 - \frac{jd}{e} \right)} \quad (12.10.4.2.4d-4)$$

$$e = \frac{M_s}{N_s} + d - \frac{h}{2} \quad (12.10.4.2.4d-5)$$

$$B_1 = \left(\frac{t_b S_\ell}{2n} \right)^{\frac{1}{3}} \quad (12.10.4.2.4d-6)$$

where:

M_s = flexural moment at service limit state (kip-in./ft)

N_s = axial thrust at service limit state (kip/ft)

d = distance from compression face to centroid of tension reinforcement (in.)

h = wall thickness (in.)

The crack control coefficients, B_1 and C_1 , are dependent on the type of reinforcement.

Crack control is assumed to be 1.0 in. from the closest tension reinforcement, even if the cover over the reinforcement is greater than or less than 1.0 in. The crack control factor, F_{cr} , in Eq. 12.10.4.2.4d-1 indicates the probability that a crack of a specified maximum width will occur.

If the ratio of e/d is less than 1.15, crack control will not govern.

- f'_c = specified compressive strength of concrete (ksi)
 C_1 = crack control coefficient for various types of reinforcement as specified in Table 12.10.4.2.4d-1
 A_s = area of steel (in.²/ft)
 b = width of section taken as 12.0 in.
 t_b = clear cover over reinforcement (in.)
 S_ℓ = spacing of circumferential reinforcement (in.)
 n = 1.0 when tension reinforcement is a single layer
 n = 2.0 when tension reinforcement is made of multiple layers
 ϕ = resistance factor for flexure as specified in Article 12.5.5

Table 12.10.4.2.4d-1—Crack Control Coefficients

Type	Reinforcement	C_1
1	Smooth wire or plain bars	1.0
2	Welded smooth wire fabric with 8.0-in. maximum spacing of longitudinals, welded deformed wire fabric, or deformed wire	1.5
3	Deformed bars or any reinforcement with stirrups anchored thereto	1.9

For Type 2 reinforcement in Table 12.10.4.2.4d-1 having $t_b^2 S_\ell / n > 3.0$, the crack width factor, F_{cr} , shall also be investigated using coefficients B_1 and C_1 specified for Type 3 reinforcement, and the larger value for F_{cr} shall be used.

Higher values for C_1 may be used if substantiated by test data and approved by the Engineer.

12.10.4.2.4e—Minimum Concrete Cover

The provisions of Article 5.12.3 shall apply to minimum concrete cover, except as follows:

- If the wall thickness is less than 2.5 in., the cover shall not be less than 0.75 in., and
- If the wall thickness is not less than 2.5 in., the cover shall not be less than 1.0 in.

12.10.4.2.5—Shear Resistance without Stirrups

C12.10.4.2.5

The section shall be investigated for shear at a critical section taken where $M_{nu}/(V_u d) = 3.0$. The factored shear resistance without radial stirrups, V_r , shall be taken as:

$$V_r = \phi V_n \quad (12.10.4.2.5-1)$$

in which:

$$V_n = 0.0316bdF_{vp}\sqrt{f'_c}(1.1 + 63\rho)\left(\frac{F_d F_n}{F_c}\right) \quad (12.10.4.2.5-2)$$

Where $F_{cr} = 1.0$, the specified reinforcement is expected to produce an average maximum crack width of 0.01 in. For $F_{cr} < 1.0$, the probability of a 0.01-in. crack is reduced, and for $F_{cr} > 1.0$, it is increased.

$$\rho = \frac{A_s}{bd} \leq 0.02 \quad (12.10.4.2.5-3)$$

- For pipes with two cages or a single elliptical cage:

$$F_d = 0.8 + \frac{1.6}{d} \leq 1.3 \quad (12.10.4.2.5-4)$$

For the purpose of this Article, a cage is considered to be a layer of reinforcement.

- For pipes not exceeding 36.0-in. diameter with a single circular cage:

$$F_d = 0.8 + \frac{1.6}{d} \leq 1.4 \quad (12.10.4.2.5-5)$$

If N_u is compressive, it is taken as positive and:

$$F_n = 1 + \frac{N_u}{24h} \quad (12.10.4.2.5-6)$$

If N_u is tensile, it is taken as negative and:

$$F_n = 1 + \frac{N_u}{6h} \quad (12.10.4.2.5-7)$$

$$F_c = 1 \pm \frac{d}{2r} \quad (12.10.4.2.5-8)$$

$$M_{nu} = M_u - N_u \left[\frac{4h - d}{8} \right] \quad (12.10.4.2.5-9)$$

The algebraic sign in Eq. 12.10.4.2.5-8 shall be taken as positive where tension is on the inside of the pipe and negative where tension is on the outside of the pipe.

where:

f'_{cmax}	=	7.0 ksi
b	=	width of design section taken as 12.0 in.
d	=	distance from compression face to centroid of tension reinforcement (in.)
h	=	wall thickness (in.)
ϕ	=	resistance factor for shear as specified in Article 5.5.4.2
r	=	radius to centerline of concrete pipe wall (in.)
N_u	=	thrust due to factored loads (kip/ft)
V_u	=	shear due to factored loads (kip/ft)
F_{vp}	=	process and material factor specified in Article 12.10.4.2.3

If the factored shear resistance, as determined herein, is not adequate, radial stirrups shall be provided in accordance with Article 12.10.4.2.6.

12.10.4.2.6—Shear Resistance with Radial Stirrups

Radial tension and shear stirrup reinforcement shall not be less than:

- For radial tension:

$$A_{vr} = \frac{1.1s_v(M_u - 0.45N_u\phi_r d)}{f_y r_s \phi_r d} \quad (12.10.4.2.6-1)$$

$$s_v \leq 0.75\phi_r d \quad (12.10.4.2.6-2)$$

- For shear:

$$A_{vs} = \frac{1.1s_v}{f_y \phi_v d} V_u F_c - V_c + A_{vr} \quad (12.10.4.2.6-3)$$

$$s_v \leq 0.75\phi_v d \quad (12.10.4.2.6-4)$$

in which:

$$V_c = \frac{4V_r}{\frac{M_{nu}}{V_u d} + 1} \leq 0.0633\phi_v b d \sqrt{f'_c} \quad (12.10.4.2.6-5)$$

where:

- M_u = flexural moment due to factored loads (kip-in./ft)
- M_{nu} = factored moment acting on cross-section width, b , as modified for effects of compressive or tensile thrust (kip-in./ft)
- N_u = thrust due to factored loads (kip/ft)
- V_u = shear due to factored loads (kip/ft)
- V_c = shear resistance of concrete section (kip/ft)
- d = distance from compression face to centroid of tension reinforcement (in.)
- f_y = specified yield strength for reinforcement; the value of f_y shall be taken as the lesser of the yield strength of the stirrup or its developed anchorage capacity (ksi)
- r_s = radius of inside reinforcement (in.)
- s_v = spacing of stirrups (in.)
- V_r = factored shear resistance of pipe section without radial stirrups per unit length of pipe (kip/ft)
- A_{vr} = stirrup reinforcement area to resist radial tension forces on cross-section width, b , in each line of stirrups at circumferential spacing, s_v (in.²/ft)
- A_{vs} = required area of stirrups for shear reinforcement (in.²/ft)
- f'_c = compressive strength of concrete (ksi)
- ϕ_v = resistance factor for shear as specified in Article 12.5.5

- ϕ_r = resistance factor for radial tension as specified in Article 12.5.5
- F_c = curvature factor as determined by Eq. 12.10.4.2.5-8

12.10.4.2.7—Stirrup Reinforcement Anchorage

12.10.4.2.7a—Radial Tension Stirrup Anchorage

When stirrups are used to resist radial tension, they shall be anchored around each circumferential of the inside cage to develop the resistance of the stirrup, and they shall also be anchored around the outside cage or embedded sufficiently in the compression side to develop the required resistance of the stirrup.

12.10.4.2.7b—Shear Stirrup Anchorage

Except as specified herein, when stirrups are not required for radial tension but required for shear, their longitudinal spacing shall be such that they are anchored around each tension circumferential or every other tension circumferential. The spacing of such stirrups shall not exceed 6.0 in.

12.10.4.2.7c—Stirrup Embedment

Stirrups intended to resist forces in the invert and crown regions shall be anchored sufficiently in the opposite side of the pipe wall to develop the required resistance of the stirrup.

12.10.4.3—Indirect Design Method

12.10.4.3.1—Bearing Resistance

Earth and live loads on the pipe shall be determined in accordance with Article 12.10.2 and compared to three-edge bearing strength D-load for the pipe. The service limit state shall apply using the criterion of acceptable crack width specified herein.

The D-load for a particular class and size of pipe shall be determined in accordance with AASHTO M 242M/M 242 (ASTM C655M and C655).

The three-edge bearing resistance of the reinforced concrete pipe, corresponding to an experimentally observed 0.01-in. width crack, shall not be less than the design load determined for the pipe as installed, taken as:

$$D = \left(\frac{12}{S_i} \right) \left(\frac{W_E + W_F}{B_{FE}} + \frac{W_L}{B_{FLL}} \right) \quad (12.10.4.3.1-1)$$

C12.10.4.2.7a

Stirrup reinforcement anchorage development research by pipe manufacturers has demonstrated that the free ends of loop-type stirrups need only be anchored in the compression zone of the concrete cross-section to develop the full tensile strength of the stirrup wire. Stirrup loop lengths equivalent to 70 percent of the wall thickness may be considered to provide adequate anchorage.

C12.10.4.3.1

The indirect design method has been the most commonly utilized method of design for buried reinforced concrete pipe. It is based on observed successful past installations.

The required D-load at which the pipe develops its ultimate strength in a three-edge bearing test is the design D-load at a 0.01-in. crack multiplied by a strength factor specified in AASHTO M 170 or M 242M/M 242 (ASTM C76 or C655M and C655) for circular pipe, M 206M/M 206 (ASTM C506M and C506) for arch pipe, and M 207M/M 207 (ASTM C507M or C507) for elliptical pipe.

where:

- B_{FE} = earth load bedding factor specified in Article 12.10.4.3.2a or Article 12.10.4.3.2b
- B_{FLL} = live load bedding factor specified in Article 12.10.4.3.2c
- S_i = internal diameter of pipe (in.)
- W_E = total unfactored earth load specified in Article 12.10.2.1 (kip/ft)
- W_F = total unfactored fluid load in the pipe as specified in Article 12.10.2.2 (kip/ft)
- W_L = total unfactored live load on unit length pipe specified in Article 12.10.2.3 (kip/ft)

For Type 1 installations, D loads, as calculated above, shall be modified by multiplying by an installation factor of 1.10.

12.10.4.3.2—Bedding Factor

The minimum compaction specified in Tables 12.10.2.1-1 and 12.10.2.1-2 shall be required by the contract document.

C12.10.4.3.2

The bedding factor is the ratio of the moment at service limit state to the moment applied in the three-edge bearing test. The standard supporting strength of buried pipe depends on the type of installation. The bedding factors given herein are based on the minimum levels of compaction indicated.

12.10.4.3.2a—Earth Load Bedding Factor for Circular Pipe

Earth load bedding factors, B_{FE} , for circular pipe are presented in Table 12.10.4.3.2a-1.

For pipe diameters, other than those listed in Table 12.10.4.3.2a-1, embankment condition bedding factors, B_{FE} , may be determined by interpolation.

C12.10.4.3.2a

The bedding factors for circular pipe were developed using the bending moments produced by the Heger pressure distributions from Figure 12.10.2.1-1 for each of the standard embankment installations. The bedding factors for the embankment condition are conservative for each installation. This conservatism is based on assuming voids and poor compaction in the haunch areas and a hard bedding beneath the pipe in determining the moments, thrusts, and shears used to calculate the bedding factors. The modeling of the soil pressure distribution used to determine moments, thrusts, and shears is also conservative by 10–20 percent, compared with the actual SPIDA analysis.

Table 12.10.4.3.2a-1—Bedding Factors for Circular Pipe

Pipe Diameter, in.	Standard Installations			
	Type 1	Type 2	Type 3	Type 4
12	4.4	3.2	2.5	1.7
24	4.2	3.0	2.4	1.7
36	4.0	2.9	2.3	1.7
72	3.8	2.8	2.2	1.7
144	3.6	2.8	2.2	1.7

12.10.4.3.2b—Earth Load Bedding Factor for Arch and Elliptical Pipe

The bedding factor for installation of arch and elliptical pipe shall be taken as:

$$B_{FE} = \frac{C_A}{C_N - xq} \quad (12.10.4.3.2b-1)$$

where:

- C_A = constant corresponding to the shape of the pipe, as specified in Table 12.10.4.3.2b-1
- C_N = parameter that is a function of the distribution of the vertical load and vertical reaction, as specified in Table 12.10.4.3.2b-1
- = parameter that is a function of the area of the vertical projection of the pipe over which lateral pressure is effective, as specified in Table 12.10.4.3.2b-1
- = ratio of the total lateral pressure to the total vertical fill load specified herein

Design values for C_A , C_N , and x are listed in Table 12.10.4.3.2b-1.

Table 12.10.4.3.2b-1—Design Values of Parameters in Bedding Factor Equation

Pipe Shape	C_A	Installation Type	C_N	Projection Ratio, p	x
Horizontal Elliptical and Arch	1.337	2	0.630	0.9	0.421
		3	0.763	0.7	0.369
Vertical Elliptical	1.021	2	0.516	0.5	0.268
				0.3	0.148
		3	0.615	0.9	0.718
				0.7	0.639
				0.5	0.457
				0.3	0.238

The value of the parameter q is taken as:

- For arch and horizontal elliptical pipe:

$$q = 0.23 \frac{P}{F_e} \left(1 + 0.35 p \frac{B_c}{H} \right) \quad (12.10.4.3.2b-2)$$

- For vertical elliptical pipe:

$$q = 0.48 \frac{P}{F_e} \left(1 + 0.73 p \frac{B_c}{H} \right) \quad (12.10.4.3.2b-3)$$

where:

- p = projection ratio, ratio of the vertical distance between the outside top of the pipe, and the ground of bedding surface to the outside vertical height of the pipe

12.10.4.3.2c—Live Load Bedding Factors

The bedding factors for live load, W_L , for both circular pipe and arch and for elliptical pipe are given in Table 12.10.4.3.2c-1. If B_{FE} is less than B_{FLL} , use B_{FE} instead of B_{FLL} , for the live load bedding factor. For pipe diameters not listed in Table 12.10.4.3.2c-1, the bedding factor may be determined by interpolation.

Table 12.10.4.3.2c-1—Bedding Factors, B_{FLL} , for the Design Truck

Fill Height, ft	Pipe Diameter, in.										
	12	24	36	48	60	72	84	96	108	120	144
0.5	2.2	1.7	1.4	1.3	1.3	1.1	1.1	1.1	1.1	1.1	1.1
1.0	2.2	2.2	1.7	1.5	1.4	1.3	1.3	1.3	1.1	1.1	1.1
1.5	2.2	2.2	2.1	1.8	1.5	1.4	1.4	1.3	1.3	1.3	1.1
2.0	2.2	2.2	2.2	2.0	1.8	1.5	1.5	1.4	1.4	1.3	1.3
2.5	2.2	2.2	2.2	2.2	2.0	1.8	1.7	1.5	1.4	1.4	1.3
3.0	2.2	2.2	2.2	2.2	2.2	2.2	1.8	1.7	1.5	1.5	1.4
3.5	2.2	2.2	2.2	2.2	2.2	2.2	1.9	1.8	1.7	1.5	1.4
4.0	2.2	2.2	2.2	2.2	2.2	2.2	2.1	1.9	1.8	1.7	1.5
4.5	2.2	2.2	2.2	2.2	2.2	2.2	2.2	2.0	1.9	1.8	1.7
5.0	2.2	2.2	2.2	2.2	2.2	2.2	2.2	2.2	2.0	1.9	1.8
5.5	2.2	2.2	2.2	2.2	2.2	2.2	2.2	2.2	2.2	2.0	1.9
6.0	2.2	2.2	2.2	2.2	2.2	2.2	2.2	2.2	2.2	2.1	2.0
6.5	2.2	2.2	2.2	2.2	2.2	2.2	2.2	2.2	2.2	2.2	2.2

12.10.4.4—Development of Quadrant Mat Reinforcement

12.10.4.4.1—Minimum Cage Reinforcement

In lieu of a detailed analysis, when quadrant mat reinforcement is used, the area of the main cage shall be no less than 25 percent of the area required at the point of maximum moment.

12.10.4.4.2—Development Length of Welded Wire Fabric

Unless modified herein, the provisions of Article 5.11.2.5 shall apply.

12.10.4.4.3—Development of Quadrant Mat Reinforcement Consisting of Welded Plain Wire Fabric

The embedment of the outermost longitudinals on each end of the circumferentials shall not be less than:

- The greater of 12 circumferential bar diameters or three-quarters of the wall thickness of the pipe beyond the point where the quadrant reinforcement is no longer required by the orientation angle, and
- A distance beyond the point of maximum flexural stress by the orientation angle plus the development length, ℓ_d , where ℓ_d is specified in Article 5.11.2.5.2.

The mat shall contain no less than two longitudinals at a distance 1.0 in. greater than that determined by the orientation angle from either side of the point requiring the maximum flexural reinforcement.

The point of embedment of the outermost longitudinals of the mat shall be at least a distance determined by the orientation angle past the point where the continuing reinforcement is no less than double the area required for flexure.

12.10.4.4.4—Development of Quadrant Mat Reinforcement Consisting of Deformed Bars, Deformed Wire, or Deformed Wire Fabric

When deformed bars, deformed wire, or deformed wire fabric is used, the circumferential bars in quadrant mat reinforcement shall satisfy the following requirements:

- Circumferentials shall extend past the point where they are no longer required by the orientation angle plus the greater of 12 wire or bar diameters or three-quarters of the wall thickness of the pipe,
- Circumferentials shall extend on either side of the point of maximum flexural stress not less than the orientation angle plus the development length, ℓ_{hd} , as required by Article 5.11.2.5.1 and modified by the applicable modification factor or factors, and
- Circumferentials shall extend at least a distance determined by the orientation angle past the point where the continuing reinforcement is no less than double the area required for flexure.

12.10.5—Construction and Installation

The contract documents shall require that the construction and installation conform to Section 27, “Concrete Culverts,” *AASHTO LRFD Bridge Construction Specifications*.

12.11—REINFORCED CONCRETE CAST-IN-PLACE AND PRECAST BOX CULVERTS AND REINFORCED CAST-IN-PLACE ARCHES

12.11.1—General

The provisions herein shall apply to the structural design of cast-in-place and precast reinforced concrete box culverts and cast-in-place reinforced concrete arches with the arch barrel monolithic with each footing.

Designs shall conform to applicable Articles of these Specifications, except as provided otherwise herein.

C12.11.1

These structures become part of a composite system comprised of the box or arch culvert structure and the soil envelope.

Precast reinforced concrete box culverts may be manufactured using conventional structural concrete and forms, or they may be machine made with dry concrete and vibrating form pipe making methods.

Standard dimensions for precast reinforced concrete box culverts are shown in AASHTO M 259 (ASTM C789) and M 273 (ASTM C850).

12.11.2—Loads and Live Load Distribution

12.11.2.1—General

Loads and load combinations specified in Table 3.4.1-1 shall apply. Live load shall be considered as specified in Article 3.6.1.3. Distribution of wheel loads and concentrated loads for culverts with less than 2.0 ft of fill shall be taken as specified in Article 4.6.2.10. For traffic traveling parallel to the span, box culverts shall be designed for a single loaded lane with the single lane multiple presence factor applied to the load. Requirements for bottom distribution reinforcement in top slabs of such culverts shall be as specified in Article 9.7.3.2 for mild steel reinforcement and Article 5.14.4.1 for prestressed reinforcement.

Distribution of wheel loads to culverts with 2.0 ft or more of cover shall be as specified in Article 3.6.1.2.6.

The dynamic load allowance for buried structures shall conform to Article 3.6.2.2.

For cast-in-place box culverts, and for precast box culverts with top slabs having span to thickness ratios (s/t) >18 or segment lengths <4.0 ft, edge beams shall be provided as specified in Article 4.6.2.1.4 as follows:

- At ends of culvert runs where wheel loads travel within 24.0 in. from the end of culvert,
- At expansion joints of cast-in-place culverts where wheel loads travel over or adjacent to the expansion joint.

12.11.2.2—Modification of Earth Loads for Soil-Structure Interaction

12.11.2.2.1—Embankment and Trench Conditions

In lieu of a more refined analysis, the total unfactored earth load, W_E , acting on the culvert may be taken as:

- For embankment installations:

$$W_E = F_e \gamma_s B_c H \quad (12.11.2.2.1-1)$$

in which:

$$F_e = 1 + 0.20 \frac{H}{B_c} \quad (12.11.2.2.1-2)$$

- For trench installations:

$$W_E = F_t \gamma_s B_c H \quad (12.11.2.2.1-3)$$

in which:

C12.11.2.1

Research into live load distribution on box culverts (McGrath et al., 2004) has shown that design for a single loaded lane with a multiple presence factor of 1.2 on the live load and using the live load distribution widths in Article 4.6.2.10 will provide adequate design loading for multiple loaded lanes with multiple presence factors of 1.0 or less when the traffic direction is parallel to the span.

The edge beam provisions are only applicable for culverts with less than 2.0 ft of fill. Precast box culverts with span to thickness ratios (s/t) ≤18 have been shown to have significantly more strength than would be predicted by Article 5.8.3 (Abolmaali and Garg, 2007). While the distribution of the load when it is applied to the edge of these structures would not be as large as would be predicted by Article 4.6.2.10, the residual strength in the structure more than compensates for the liberal load distribution.

$$F_t = \frac{C_d B_d^2}{HB_c} \leq F_e \quad (12.11.2.2.1-4)$$

where:

- W_E = total unfactored earth load (kip/ft)
 B_c = outside width of culvert as specified in Figures 12.11.2.2.1-1 or 12.11.2.2.1-2, as appropriate (ft)
 H = depth of backfill as specified in Figures 12.11.2.2.1-1 or 12.11.2.2.1-2 (ft)
 F_e = soil-structure interaction factor for embankment installation specified herein
 F_t = soil-structure interaction factor for trench installations specified herein
 γ_s = unit weight of backfill (kcf)
 B_d = horizontal width of trench as specified in Figure 12.11.2.2.1-2 (ft)
 C_d = a coefficient specified in Figure 12.11.2.2.1-3

F_e shall not exceed 1.15 for installations with compacted fill along the sides of the box section, or 1.40 for installations with uncompacted fill along the sides of the box section.

For wide trench installations where the trench width exceeds the horizontal dimension of the culvert across the trench by more than 1.0 ft, F_t shall not exceed the value specified for an embankment installation.

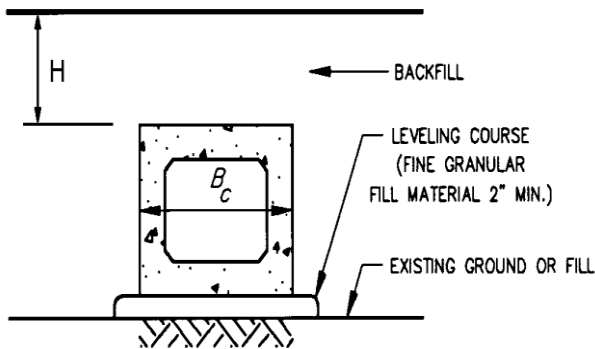

EMBANKMENT CONDITION

Figure 12.11.2.2.1-1—Embankment Condition—Precast Concrete Box Sections

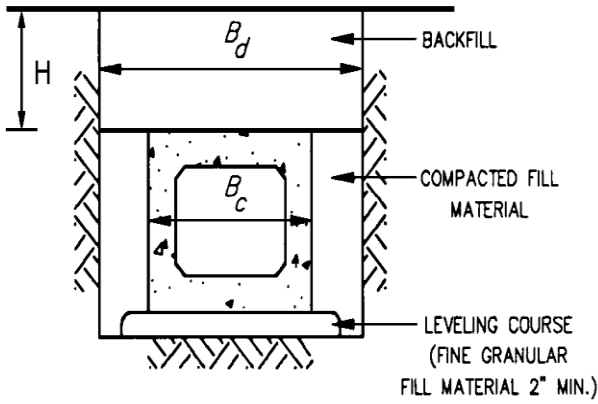

TRENCH CONDITION

Figure 12.11.2.2.1-2—Trench Condition—Precast Concrete Box Sections

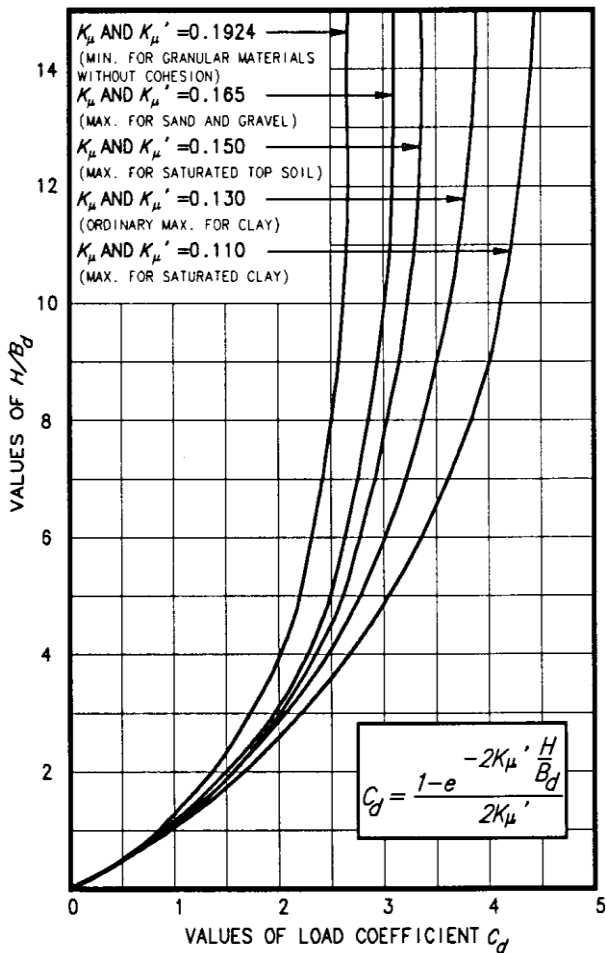

Figure 12.11.2.2.1-3—Coefficient C_d for Trench Installations

12.11.2.2—Other Installations

Methods of installation other than embankment or trench may be used to reduce the loads on the culvert, including partial positive projection, 0.0 projection, negative projection, induced trench, and jacked installations. The loads for such installations may be determined by accepted methods based on tests, soil-structure interaction analyses, or previous experience.

12.11.2.3—Distribution of Concentrated Loads to Bottom Slab of Box Culvert

The width of the top slab strip used for distribution of concentrated wheel loads, specified in Article 12.11.2, shall also be used for the determination of moments, shears, and thrusts in the side walls and the bottom slab.

12.11.2.4—Distribution of Concentrated Loads in Skewed Box Culverts

Wheel distribution specified in Article 12.11.2.3 need not be corrected for skew effects.

12.11.3—Service Limit State

The provisions of Article 5.7.3.4 shall apply to crack width control in reinforced concrete cast-in-place and precast box culverts and reinforced cast-in-place arches.

C12.11.2.3

Restricting the live load distribution width for the bottom slab to the same width used for the top slab provides designs suitable for multiple loaded lanes, even though analysis is only completed for a single loaded lane (as discussed in Article C12.11.2.1).

While typical designs assume a uniform pressure distribution across the bottom slab, a refined analysis that considers the actual soil stiffness under box sections will result in pressure distributions that reduce bottom slab shear and moment forces (McGrath et al., 2004).

Such an analysis requires knowledge of in-situ soil properties to select the appropriate stiffness for the supporting soil. A refined analysis taking this into account may be beneficial when analyzing existing culverts.

C12.11.3

Buried box culverts are subject to high compressive thrust forces compared to most flexural members and this thrust can result in a substantial reduction in the stresses at the service limit state that is often ignored in design. The following Equations, derived from ACI SP-3 can be used to consider the effect of thrust on stresses at the service limit state:

$$f_s = \frac{M_s + N_s \left(d - \frac{h}{2} \right)}{(A_s j i d)} \quad (\text{C12.11.3-1})$$

in which:

$$e = M_s / N_s + d - h/2$$

$$i = 1 / (1 - j d / e)$$

$$j = 0.74 + 0.1 e / d \leq 0.9$$

where:

M_s	=	flexural moment at service limit state (kip-in./ft)
N_s	=	axial thrust at service limit state (kip/ft)
d	=	distance from compression face to centroid of tension reinforcement (in.)
h	=	wall thickness (in.)
A_s	=	area of reinforcement per unit length (in. ² /ft)
f_s	=	reinforcement stress under service load condition (ksi)
e/d min	=	1.15 (dim.)

12.11.4—Safety against Structural Failure

12.11.4.1—General

All sections shall be designed for the applicable factored loads specified in Table 3.4.1-1 at the strength limit state, except as modified herein. Shear in culverts shall be investigated in conformance with Article 5.14.5.3.

12.11.4.2—Design Moment for Box Culverts

Where monolithic haunches inclined at 45 degrees are specified, negative reinforcement in walls and slabs may be proportioned based on the flexural moment at the intersection of the haunch and uniform depth member. Otherwise, the provisions of Section 5 shall apply.

12.11.4.3—Minimum Reinforcement

12.11.4.3.1—Cast-in-Place Structures

Reinforcement shall not be less than that specified in Article 5.7.3.3.2 at all cross-sections subject to flexural tension, including the inside face of walls. Shrinkage and temperature reinforcement shall be provided near the inside surfaces of walls and slabs in accordance with Article 5.10.8.

12.11.4.3.2—Precast Box Structures

At all cross-sections subjected to flexural tension, the ratio of primary flexural reinforcement in the direction of the span to gross concrete area shall be not less than 0.002. Such minimum reinforcement shall be provided at the inside faces of walls and in each direction at the top of slabs of box sections having less than 2.0 ft of cover.

The provisions of Article 5.10.8 shall not apply to precast concrete box sections fabricated in lengths not exceeding 16.0 ft. Where the fabricated length exceeds 16.0 ft, the minimum longitudinal reinforcement for shrinkage and temperature should be in conformance with Article 5.10.8.

12.11.4.4—Minimum Cover for Precast Box Structures

The provisions of Article 5.12.3 shall apply unless modified herein for precast box structures.

If the height of the fill is <2.0 ft, the minimum cover in the top slab shall be 2.0 in. for all types of reinforcement.

Where welded wire fabric is used, the minimum cover shall be the greater of three times the diameter of the wire or 1.0 in.

12.11.5—Construction and Installation

The contract documents shall require that construction and installation conform to Section 27, “Concrete Culverts,” *AASHTO LRFD Bridge Construction Specifications*.

12.12—THERMOPLASTIC PIPES

12.12.1—General

The provisions herein shall apply to the structural design of buried thermoplastic pipe with solid, corrugated, or profile wall, manufactured of PE or PVC.

C12.12.1

These structures become part of a composite system comprised of the plastic pipe and the soil envelope.

The following specifications are applicable:

For PE:

- Solid Wall—ASTM F714,
- Corrugated—AASHTO M 294, and
- Profile—ASTM F894.

For PVC:

- Solid Wall—AASHTO M 278 and
- Profile—AASHTO M 304.

12.12.2—Service Limit States

12.12.2.1—General

The allowable maximum localized distortion of installed plastic pipe shall be limited based on the service requirements and overall stability of the installation. The extreme fiber tensile strain shall not exceed the allowable long-term strain in Table 12.12.3.3-1. The net tension strain shall be the numerical difference between the bending tensile strain and ring compression strain.

C12.12.2.1

The allowable long-term strains should not be reached in pipes designed and constructed in accordance with this Specification. Deflections resulting from conditions imposed during pipe installation should also be considered in design.

12.12.2.2—Deflection Requirement

Total deflection, Δ_t , shall be less than the allowable deflection, Δ_A , as follows:

C12.12.2.2

Deflection is controlled through proper construction in the field, and construction contracts should place responsibility for control of deflections on

$$\Delta_t \leq \Delta_A \quad (12.12.2.2-1)$$

where:

Δ_t = total deflection of pipe expressed as a reduction of the vertical diameter taken as positive for reduction of the vertical diameter and expansion of horizontal diameter. (in.)

Δ_A = total allowable deflection of pipe, reduction of vertical diameter (in.)

Total deflection, calculated using Spangler's expression for predicting flexural deflection in combination with the expression for circumferential shortening, shall be determined as:

$$\Delta_t = \frac{K_B (D_L P_{sp} + C_L P_L) D_o}{1000 (E_p I_p / R^3 + 0.061 M_s)} + \epsilon_{sc} D \quad (12.12.2.2-2)$$

in which:

$$\epsilon_{sc} = \frac{T_s}{1000 (A_{eff} E_p)} \quad (12.12.2.2-3)$$

$$T_s = P_s \left(\frac{D_o}{2} \right) \quad (12.12.2.2-4)$$

where:

ϵ_{sc} = service compressive strain due to thrust, as specified in Article 12.12.3.10.1c and taken as positive for compression

T_s = service thrust per unit length (lb/in.)

D_L = deflection lag factor, a value of 1.5 is typical

K_B = bedding coefficient, a value of 0.10 is typical

P_{sp} = soil prism pressure (EV), evaluated at pipe springline (psi)

C_L = live load distribution coefficient

P_L = design live load pressure including vehicle, dynamic load allowance, and multiple presence effect (psi)

D_o = outside diameter of pipe (in.) as shown in Figure C12.12.2.2-1

E_p = short- or long-term modulus of pipe material as specified in Table 12.12.3.3-1 (ksi)

I_p = moment of inertia of pipe profile per unit length of pipe (in.⁴/in.)

R = radius from center of pipe to centroid of pipe profile (in.) as shown in Figure C12.12.2.2-1

the contractor. However, feasibility of a specified installation needs to be checked prior to writing the project specifications.

The construction specifications set the allowable deflection, Δ_A , for thermoplastic pipe at five percent as a generally appropriate limit. The Engineer may allow alternate deflection limits for specific projects if calculations using the design method in this section show that the pipe meets all of the strength-limit-state requirements.

Eq. 12.12.2.2-2 uses the constrained soil modulus, M_s , as the soil property. Note that the soil prism load is used as input, rather than the reduced load used to compute thrust.

This check should be completed to determine that the expected field deflection based on thrust and flexure is lower than the maximum allowable deflection for the project.

Thrust and hoop strain in the pipe wall are defined positive for compression.

There are no standard values for the deflection lag factor. Values from 1.0 to 6.0 have been recommended. The highest values are for installations with quality backfill and low initial deflections and do not generally control designs. A value of 1.5 provides some allowance for increase in deflection over time for installations with initial deflection levels of several percent.

The bedding coefficient, K_B varies from 0.083 for full support to 0.110 for line support at the invert. Haunching is always specified to provide good support; however, it is still common to use a value of K_B equal to 0.10 to account for inconsistent haunch support.

- D = diameter to centroid of pipe profile (in.) as shown in Figure C12.12.2.2-1
- M_s = secant constrained soil modulus, as specified in Article 12.12.3.5-1 (ksi)
- P_s = design service load (psi)
- A_{eff} = effective area of pipe wall per unit length of pipe as specified in Article 12.12.3.10.1b (in.²/in.)

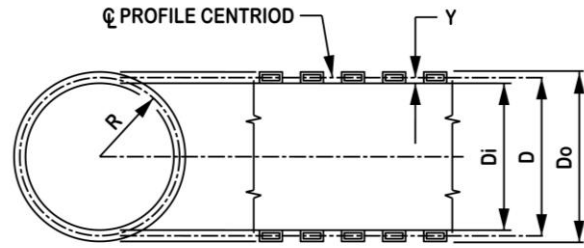

Figure C12.12.2.2-1—Schematic for Thermoplastic Pipe Terms

12.12.3—Safety against Structural Failure

12.12.3.1—General

Buried thermoplastic culverts shall be investigated at the strength limit states for thrust, general and local buckling, and combined strain.

12.12.3.2—Section Properties

Section properties for thermoplastic pipe, including wall area, moment of inertia, and profile geometry should be determined from cut sections of pipe or obtained from the pipe manufacturer.

12.12.3.3—Chemical and Mechanical Requirements

Mechanical properties for design shall be as specified in Table 12.12.3.3-1.

Except for buckling, the choice of either initial or long-term mechanical property requirements, as appropriate for a specific application, shall be determined by the Engineer. Investigation of general buckling shall be based on the value of modulus of elasticity that represents the design life of the project.

C12.12.3.1

Total compressive strain in a thermoplastic pipe can cause yielding or buckling, and total tensile strain can cause cracking.

C12.12.3.2

Historically, AASHTO bridge specifications have contained minimum values for the moment of inertia and wall area of thermoplastic pipe; however, these values have been minimum values and are not meaningful for design. This is particularly so since provisions to evaluate local buckling were introduced in 2001. These provisions require detailed profile geometry that varies with manufacturer. Thus, there is no way to provide meaningful generic information on section properties. A convenient method for determining section properties for profile wall pipe is to make optical scans of pipe wall cross-sections and determine the properties with a computer drafting program.

C12.12.3.3

Properties in Table 12.12.3.3-1 include “initial” and long-term values. No product standard requires determining the actual long-term properties; thus, there is some uncertainty in the actual values. However, pipe designed with the Table 12.12.3.3-1 values for 50-yr modulus of elasticity have performed well, and the properties are assumed to be reasonably conservative. Estimated values for a modulus of elasticity for a 75-yr design life have been estimated from relaxation tests on PVC and PE in parallel plate tests. The tests were conducted for over two years and show that the modulus of elasticity reduces approximately linearly with the logarithm of time. Further, with a log-linear extrapolation, the differences between 50-yr and 75-yr modulus values are very small. These values should be reasonably conservative, with the same reliability as the 50-yr values. Pipe and thermoplastic resin suppliers should be asked to provide confirmation of long-term modulus values for any

particular product. Values should meet or exceed those provided in Table 12.12.3.3-1. Where service life is in excess of 75 yr, test data may be used for the desired life.

The service long-term tension strain limit and the factored compression strain limit in Table 12.12.3.3-1 need to be multiplied by the appropriate resistance factors to obtain the strain limits.

Table 12.12.3.3-1—Mechanical Properties of Thermoplastic Pipe

Type of Pipe	Minimum Cell Class	Service Long-Term Tension Strain Limit, ϵ_{yt} (%)	Factored Compr. Strain Limit, ϵ_{yc} (%)	Initial		50-yr		75-yr	
				F_u min (ksi)	E min (ksi)	F_u min (ksi)	E min (ksi)	F_u min (ksi)	E min (ksi)
Solid Wall PE Pipe – ASTM F714	ASTM D3350, 335434C	5.0	4.1	3.0	110.0	1.44	22	1.40	21
Corrugated PE Pipe – AASHTO M 294	ASTM D3350, 435400C	5.0	4.1	3.0	110.0	0.90	22	0.90	21
Profile PE Pipe – ASTM F894	ASTM D3350, 334433C	5.0	4.1	3.0	80.0	1.12	20	1.10	19
	ASTM D3350, 335434C	5.0	4.1	3.0	110.0	1.44	22	1.40	21
Solid Wall PVC Pipe – AASHTO M 278, ASTM F679	ASTM D1784, 12454C	5.0	2.6	7.0	400.0	3.70	140	3.60	137
	ASTM D1784, 12364C	3.5	2.6	6.0	440.0	2.60	158	2.50	156
Profile PVC Pipe – AASHTO M 304	ASTM D1784, 12454C	5.0	2.6	7.0	400.0	3.70	140	3.60	137
	ASTM D1784, 12364C	3.5	2.6	6.0	440.0	2.60	158	2.50	156

12.12.3.4—Thrust

Loads on buried thermoplastic pipe shall be based on the soil prism load, modified as necessary to consider the effects of pipe-soil interaction. Calculations shall consider the duration of a load when selecting pipe properties to be used in design. Live loads need not be considered for the long-term loading condition.

12.12.3.5—Factored and Service Loads

The factored load, P_u , in psi shall be taken as:

$$P_u = \eta_{EV} (\gamma_{EV} K_{\gamma E} K_2 V A F P_{sp} + \gamma_{WA} P_w) + \eta_{LL} \gamma_{LL} P_L C_L \quad (12.12.3.5-1)$$

The service load, P_s , in psi shall be taken as:

C12.12.3.4

Because of the time-dependent nature of thermoplastic pipe properties, the load will vary with time.

Time of loading is an important consideration for some types of thermoplastic pipe. Live loads and occasional flood conditions are normally considered short-term loads. Earth loads or permanent high groundwater are normally considered long-term loads.

C12.12.3.5

For η factors, refer to Article 12.5.4 regarding assumptions about redundancy for earth loads and live loads.

The factor K_2 is introduced to consider variation in thrust around the circumference, which is necessary when combining thrust with moment or thrust due to earth and live load under shallow fill. K_2 is set at 1.0 to determine thrust at the springline and 0.6 to determine

$$P_s = K_2 VAF P_{sp} + P_L C_L + P_w \quad (12.12.3.5-2)$$

in which:

$$VAF = 0.76 - 0.71 \left(\frac{S_H - 1.17}{S_H + 2.92} \right) \quad (12.12.3.5-3)$$

$$S_H = \frac{\phi_s M_s R}{E_p A_g} \quad (12.12.3.5-4)$$

$$C_L = \frac{L_w}{D_o} \leq 1.0 \quad (12.12.3.5-5)$$

$$L_w = L_0 + 12 \cdot LLDF(H) \quad (12.12.3.5-6)$$

where:

$K_{\gamma E}$ = installation factor typically taken as 1.5 to provide traditional safety. Use of a value less than 1.5 requires additional monitoring of the installation during construction and provisions for such monitoring shall be provided on the contract documents.

K_2 = coefficient to account for variation of thrust around the circumference
 = 1.0 for thrust at the springline
 = 0.6 for thrust at the crown
 VAF = vertical arching factor

thrust at the crown. The term P_L is also modified for this reason in later sections.

Figure C3.11.3-1 shows the effect of groundwater on the earth pressure. P_{sp} does not include the hydrostatic pressure. P_{sp} is the pressure due to the weight of soil above the pipe and should be calculated based on the wet density for soil above the water table and based on the buoyant density for soil below the water table. See Table 3.5.1-1 for common unit weights.

In computing L_w , add axle spacing (and increase total live load) if depth is sufficient for axle loads to interact.

The factor $K_{\gamma E}$ is introduced to provide the same safety level as traditionally used for thermoplastic culverts. Designers may consider using values of $K_{\gamma E}$ as low as 1.0 provided that procedures are implemented to ensure compliance with construction specifications. For culvert designs completed with an installation factor less than 1.5, the designer is required to specify additional minimum performance measures such as testing, monitoring, construction controls, gradation and backfill requirements including active monitoring of the backfill gradation and compaction (see Article 30.7.4 of *AASHTO LRFD Bridge Construction Specifications*). The construction controls include deflection measurements and shall require the Contractor to submit and get approval from the Owner's Engineer for his/her construction plan to be used to achieve the more stringent performance measures which allowed for the use of a smaller installation factor in the design. Backfill placement and monitoring shall be done at levels along the side of the culvert and includes measurement of change in vertical pipe diameter when the backfill reaches the top of the pipe. As the backfill nears the top of pipe the vertical pipe diameter should be greater than the vertical diameter prior to backfilling, but not more than three percent greater than the vertical diameter prior to backfilling.

The use of the vertical arching factor is based on the behavior, demonstrated by Burns and Richard (1964), that pipe with high hoop-stiffness ratios (S_H , ratio of soil stiffness to pipe hoop stiffness) carry substantially less load than the weight of the prism of soil directly over the pipe. This behavior was demonstrated experimentally by Hashash and Selig (1990) and analytically by Moore (1995). McGrath (1999) developed the simplified form of the equation presented in this Section.

The VAF approach is only developed for the embankment load case. No guidance is currently

S_H	=	hoop stiffness factor
P_w	=	hydrostatic water pressure at the springline of the pipe (psi)
C_L	=	live load distribution coefficient
L_w	=	live load distribution width in the circumferential direction at the elevation of the crown (in.)
H	=	depth of cover (ft)
η_{EV}	=	load modifier as specified in Article 1.3.2, as they apply to vertical earth loads on culverts
γ_{EV}	=	load factor for vertical pressure from dead load of earth fill, as specified in Article 3.4.1
P_{sp}	=	soil prism pressure (EV), evaluated at pipe springline (psi)
γ_{WA}	=	load factor for hydrostatic pressure, as specified in Article 3.4.1
η_{LL}	=	load modifier as specified in Article 1.3.2, as they apply to live loads on culverts
γ_{LL}	=	load factor for live load, as specified in Article 3.4.1
P_L	=	live load pressure (<i>LL</i>) with dynamic load allowance (psi)
ϕ_s	=	resistance factor for soil stiffness
M_s	=	secant constrained soil modulus as specified in Table 12.12.3.5-1 (ksi)
R	=	radius from center of pipe to centroid of pipe profile (in.)
E_p	=	short- or long-term modulus of pipe material as specified in Table 12.12.3.3-1 (ksi)
A_g	=	gross area of pipe wall per unit length of pipe (in. ² /in.)

available to predict the reduced loads on pipe in trench conditions. The only trench load theory proposed for flexible pipe was that by Spangler, which does not have good guidance on selection of input parameters. It is conservative to use the *VAF* approach as presented for embankments.

If evaluating the short-term load condition, then use the initial modulus of elasticity to compute S_H . Similarly, if evaluating the long-term loading condition, then use the long-term modulus of elasticity to compute S_H .

The term ϕ_s appears in Eq. 12.12.3.5-4 to account for variability in backfill compaction. A lower level of compaction increases the applied thrust force on the pipe.

For selecting values of the constrained soil modulus, M_s , prior editions of the specifications contained the commentary “Suggested practice is to design for a standard Proctor backfill density five percent less than specified by the contract documents.” This statement is not considered necessary with the addition of post-construction inspection guidelines to the *AASHTO LRFD Bridge Construction Specifications*, which should provide reasonable assurance that the design condition is achieved.

For culverts in trench installations under depths of fill greater than 10.0 ft, evaluation of the values of M_s for in-situ soil for a width one diameter either side of the pipe is not necessary, provided the in-situ soil has adequate vertical; and lateral stiffness. Stable trench walls, during the excavation process, are predictive of adequate vertical and lateral stiffness.

D_o	=	outside diameter of pipe (in.)
W_0	=	width of live load ground-surface contact area parallel to flow in pipe as specified in Article 3.6.1.2.5 (in.)
$LLDF$	=	factor for distribution of live load through earth fills in Article 3.6.1.2.6

In the absence of site-specific data, the secant constrained soil modulus, M_s , may be selected from Table 12.12.3.5-1 based on the backfill type and density and the geostatic earth pressure, P_{sp} . Linear interpolation between soil stress levels may be used for the determination of M_s .

For culverts in embankment or wide trench installations under depths of fill up to 10.0 ft, the soil type and density selected from Table 12.12.3.5-1 shall be representative of the conditions for a width of one-half diameter each side of the culvert, but never less than 18.0 in. on each side of the culvert. For culverts under depths of fill greater than 10.0 ft, the soil type and density selected shall be representative of the conditions for a width of one diameter on each side of the culvert.

The constrained modulus may also be determined experimentally using the stress-strain curve resulting from a uniaxial strain test on a sample of soil compacted to the field-specified density. The constrained modulus is the slope of the secant from the origin of the curve to a point on the curve corresponding to the soil prism pressure, P_{sp} , Figure C12.12.3.5-1.

Installation in narrow trenches reduces the vertical load, provided vertical stiffness of the soil is adequate to carry the load that is distributed around the pipe due to arching, as represented by the vertical arching factor (VAF) in the design method and adequate space is preserved at the side of the pipe to place and compact backfill. The minimum trench widths provided in the *AASHTO LRFD Bridge Construction Specifications* are set to provide adequate space. Narrow trenches yield a desirable level of conservatism, since the transfer of the load to in-situ trench wall is not considered in flexible pipe design.

If the structural backfill material is compacted crushed stone, then the secant constrained soil modulus, M_s , values for Sn-100 may be used. If the backfill is uncompacted (dumped) crushed stone, use the modulus values for Sn-90. While it is not common practice to monitor density of crushed stone backfills, experience has found that a modest compaction effort improves culvert performance and allows the use of the compacted values.

The width of structural backfill is an important consideration when the in situ soil in the trench wall or the embankment fill at the side of the structural backfill is soft. Currently, only AWWA Manual M45, The Fiberglass Pipe Design Manual, addresses this issue.

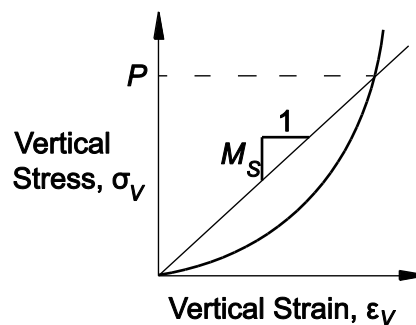

Figure C12.12.3.5-1—Schematic One-Dimensional Stress-Strain Curve of Soil Backfill

Table 12.12.3.5-1— M_s Based on Soil Type and Compaction Condition

P_{sp} Stress Level (psi)	Sn-100 (ksi)	Sn-95 (ksi)	Sn-90 (ksi)	Sn-85 (ksi)
1.0	2.350	2.000	1.275	0.470
5.0	3.450	2.600	1.500	0.520
10.0	4.200	3.000	1.625	0.570
20.0	5.500	3.450	1.800	0.650
40.0	7.500	4.250	2.100	0.825
60.0	9.300	5.000	2.500	1.000
P_{sp} Stress Level (psi)		Si-95 (ksi)	Si-90 (ksi)	Si-85 (ksi)
1.0		1.415	0.670	0.360
5.0		1.670	0.740	0.390
10.0		1.770	0.750	0.400
20.0		1.880	0.790	0.430
40.0		2.090	0.900	0.510
60.0				
P_{sp} Stress Level (psi)		Cl-95 (ksi)	Cl-90 (ksi)	Cl-85 (ksi)
1.0		0.530	0.255	0.130
5.0		0.625	0.320	0.175
10.0		0.690	0.355	0.200
20.0		0.740	0.395	0.230
40.0		0.815	0.460	0.285
60.0		0.895	0.525	0.345

1. The soil types are defined by a two-letter designation that indicates general soil classification, Sn for sands and gravels, Si for silts and Cl for clays. Specific soil groups that fall into these categories, based on ASTM D2487 and AASHTO M 145, are listed in Table 12.12.3.5-2.
2. The numerical suffix to the soil type indicates the compaction level of the soil as a percentage of maximum dry density determined in accordance with AASHTO T 99.

Table 12.12.3.5-2—Equivalent ASTM and AASHTO Soil Classifications

Basic Soil Type (1)	ASTM D2487	AASHTO M 145
Sn (Gravelly sand, SW)	SW, SP (2) GW, GP sands and gravels with 12% or less fines	A1, A3 (2)
Si (Sandy silt, ML)	GM, SM, ML also GC and SC with less than 20% passing a No. 200 sieve	A-2-4, A-2-5, A4
Cl (Silty clay, CL)	CL, MH, GC, SC also GC and SC with more than 20% passing a No. 200 sieve	A-2-6, A-2-7, A5, A6

1. The soil classification listed in parentheses is the type that was tested to develop the constrained soil modulus values in Table 12.12.3.5-1. The correlations to other soil types are approximate.
2. Uniformly graded materials with an average particle size smaller than a No. 40 sieve shall not be used as backfill for thermoplastic culverts unless specifically allowed in the contract documents and special precautions are taken to control moisture content and monitor compaction levels.

12.12.3.6—Handling and Installation Requirements

The flexibility factor, FF , in./kip shall be taken as:

$$FF = \frac{S^2}{EI} \quad (12.12.3.6-1)$$

where:

- I = moment of inertia (in.⁴/in.)
- E = initial modulus of elasticity (ksi)
- S = diameter of pipe (in.)

The flexibility factor, FF , shall be limited as specified in Article 12.5.6.3.

12.12.3.7—Soil Prism

The soil-prism load shall be calculated as a pressure representing the weight of soil above the pipe springline. The pressure shall be calculated for three conditions:

- If the water table is above the top of the pipe and at or above the ground surface:

$$P_{sp} = \frac{\left(H + 0.11 \frac{D_o}{12}\right) \gamma_b}{144} \quad (12.12.3.7-1)$$

- If the water table is above the top of the pipe and below the ground surface:

$$P_{sp} = \frac{1}{144} \left[\left[\left(H_w - \frac{D_o}{24} \right) + 0.11 \frac{D_o}{12} \right] \gamma_b + \left[H - \left(H_w - \frac{D_o}{24} \right) \right] \gamma_s \right] \quad (12.12.3.7-2)$$

- If the water table is below the top of the pipe:

$$P_{sp} = \frac{\left(H + 0.11 \frac{D_o}{12}\right) \gamma_s}{144} \quad (12.12.3.7-3)$$

where:

- P_{sp} = soil-prism pressure (EV), evaluated at pipe springline (psi)
- D_o = outside diameter of pipe (in.)
- γ_b = unit weight of buoyant soil (lb/ft³)
- H = depth of fill over top of pipe (ft)
- H_w = depth of water table above springline of pipe (ft)
- γ_s = wet unit weight of soil (lb/ft³)

C12.12.3.7

The soil prism load and vertical arching factor, VAF , serve as a common reference for the load on all types of pipe.

The soil prism calculation needs to consider the unit weight of the backfill over the pipe. Use the wet unit weight above the water table and the buoyant unit weight below the water table. In cases where the water table fluctuates, multiple conditions may need to be evaluated.

Figure C3.11.3-1 shows the effect of groundwater on the earth pressure. See Table 3.5.1-1 for common unit weights.

12.12.3.8—Hydrostatic Pressure

The pressure due to ground water shall be calculated as:

$$P_w = \frac{\gamma_w K_{wa} H_w}{144} \quad (12.12.3.8-1)$$

where:

- P_w = hydrostatic water pressure at the springline of the pipe (psi)
- γ_w = unit weight of water (lb/ft³)
- K_a = factor for uncertainty in level of groundwater table

12.12.3.9—Live Load

The live load shall be determined as a pressure applied at the pipe crown. The live load magnitude shall be based on the design vehicular live load in Article 3.6.1.2 and shall include modifiers for multiple presence/overload, dynamic load allowance, and distribution through cover soils.

The live load pressure, P_L , shall be taken as:

$$P_L = \frac{P(1+IM/100)m}{[L_0 + (12H + K_1)LLDF][W_0 + (12H + K_1)LLDF]} \quad (12.12.3.9-1)$$

where:

- P_L = service live load on culvert (psi)
- P = design wheel load as specified in Article 3.6.1.2 (lbs)
- IM = dynamic load allowance as specified in Article 3.6.2.2 (%)
- m = multiple presence factor as specified in Table 3.6.1.1.2-1
- L_0 = length of live load surface contact area parallel to pipe diameter as specified in Article 3.6.1.2.5 (in.)
- H = depth of fill over top of pipe (ft)
- $LLDF$ = factor for distribution of live load through earth fills as specified in Article 3.6.1.2.6
- W_0 = width of live load ground surface contact area parallel to flow in pipe as specified in Article 3.6.1.2.5 (in.)
- K_1 = coefficient to consider design location (in.)
 - = 0 for live load at the crown of the pipe
 - = $D_0/2$ for live load at the springline

C12.12.3.8

Hydrostatic loading due to external water pressure should be calculated in all cases where water table may be above the pipe springline at any time. This load contributes to hoop thrust but does not affect deflection.

There is often uncertainty in the level of the groundwater table and its annual variations. The designer may use the factor K_{wa} with values up to 1.3 to account for this uncertainty or may select conservative values of H_w with a lower value of K_{wa} but not less than 1.

C12.12.3.9

Live load calculations are included here to demonstrate the computation of live load thrust at the crown and springline. NCHRP Project 15-29 to revise this is nearing completion. This project is proposing no changes to the live load distribution.

Increase as necessary if depth is sufficient for wheels and/or axles to interact.

Add axle spacing if depth is sufficient for axles to interact.

Add wheel spacing if depth is sufficient for wheels to interact.

Setting the term K_1 to 0 is the normal assumption in distributing live loads to the pipe and accounts for the load attenuating to the top of the pipe; however, the load continues to spread longitudinally along the pipe as it attenuates from the crown to the springline. Using the term $K_1 = D_0/2$ provides a means to account for this.

12.12.3.10—Wall Resistance

12.12.3.10.1—Resistance to Axial Thrust

12.12.3.10.1a—General

Elements of profile wall pipe shall be designed to resist local buckling. To determine local buckling resistance, profile-wall pipe geometry shall be idealized as specified herein and an effective area determined in accordance with the following provisions.

12.12.3.10.1b—Local Buckling Effective Area

For the determination of buckling resistance, profile wall pipe shall be idealized as straight elements. Each element shall be assigned a width based on the clear distance between the adjoining elements and a thickness based on the thickness at the center of the element. The idealization of a typical corrugated profile should be based on the approximation in Figure 12.12.3.10.1b-1.

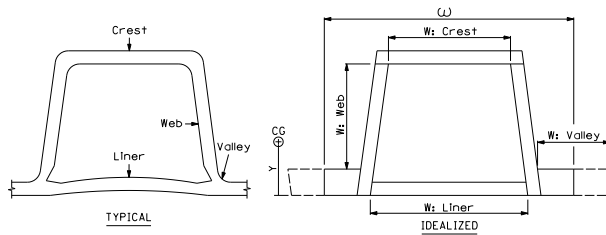

Figure 12.12.3.10.1b-1—Typical and Idealized Cross-Section of Profile Wall Pipe

To evaluate the resistance to axial thrust, the area of the profile shall be reduced to an effective area, A_{eff} , for local buckling effects. The effective area of the profile shall be determined by subtracting the ineffective area of each element from the gross section area, as:

$$A_{eff} = A_g - \frac{\sum (w - b_e)t}{\omega} \tag{12.12.3.10.1b-1}$$

in which:

$$b_e = \rho w \tag{12.12.3.10.1b-2}$$

$$\rho = \frac{\left(1 - \frac{0.22}{\lambda}\right)}{\lambda} \tag{12.12.3.10.1b-3}$$

$$\lambda = \left(\frac{w}{t}\right) \sqrt{\frac{E_{yc}}{k}} \geq 0.673 \tag{12.12.3.10.1b-4}$$

C12.12.3.10.1b

To complete the local buckling calculations, the profile is idealized into a group of rectangular elements. To complete the idealization, it should include:

- The actual total area.
- If the crest element is curved, it should be idealized at the centroid of the curvature. The idealized element need not touch the idealized webs.

See McGrath et al (2009) for guidance on other profile types.

The resistance to local buckling is based on the effective width concept used by the cold formed steel industry. This theory assumes that even though buckling is initiated in the center of a plate element, the element still has substantial post-buckling strength at the edges where the element is supported. This concept is demonstrated in Figure C12.12.3.10.1b-1.

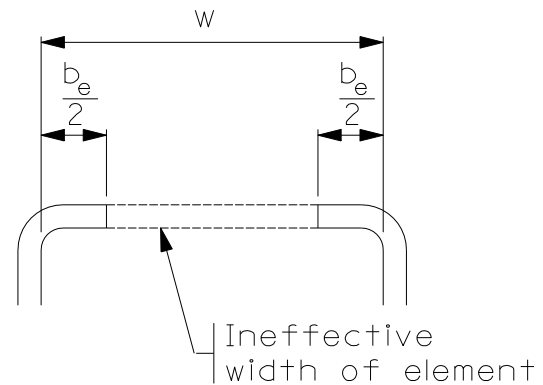

Figure C12.12.3.10.1b-1—Effective Width Concept

The local buckling evaluation reduces the capacity of pipe wall sections with high ratios of width to thickness.

The calculations in Eqs. 12.12.3.10.1b-1 to 12.12.3.10.1b-4 must be repeated for each element in the idealized profile.

where:

- A_{eff} = effective area of pipe wall per unit length of pipe (in.²/in.)
 b_e = element effective width (in.)
 ρ = effective width factor
 λ = slenderness factor
 ω = spacing of corrugation (in.) as specified in Figure 12.12.3.10.1b-1
 ϵ_{yc} = factored compressive strain limit as specified in Table 12.12.3.3-1
 A_g = gross area of pipe wall per unit length of pipe (in.²/in.)
 t = thickness of element (in.)
 w = total clear width of element between supporting elements (in.)
 k = plate buckling coefficient, $k=4$ for supported elements, $k=0.43$ for unsupported elements, such as free standing ribs

As an alternate to determining the effective area by the calculation procedure presented above, the results of the stub compression test, AASHTO T 341, may be used, in which case the effective area A_{eff} shall satisfy:

$$A_{eff} = \frac{P_{st} K_t}{F_u} \leq A_g \quad (12.12.3.10.1b-5)$$

in which:

- P_{st} = stub compression capacity from T 341 (kip/in.)
 K_t = time factor as specified in Table 12.12.3.10.1b-1
 F_u = material yield strength for design load duration (ksi)

Table 12.12.3.10.1b-1—Time Factor

Time Period	PE	PVC
Initial	0.9	0.95
50 yr	0.3	0.6
75 yr (est.)	0.25	0.5

12.12.3.10.1c—Compression Strain

The factored compressive strain due to factored thrust, ϵ_{uc} , and the service compressive strain due to service thrust, ϵ_{sc} , shall be taken as:

$$\epsilon_{uc} = \frac{T_u}{1000 A_{eff} E_p} \quad (12.12.3.10.1c-1)$$

The plate buckling coefficient is analogous to the effective length factor, k , in column buckling.

The stub compression test has been incorporated as a requirement into AASHTO product standards M 294 and M 304. The test data should be readily available from manufacturers and quality control tests.

$$\epsilon_{sc} = \frac{T_s}{1000(A_{eff}E_p)} \quad (12.12.3.10.1c-2)$$

in which:

$$T_u = P_u \left(\frac{D_o}{2} \right) \quad (12.12.3.10.1c-3)$$

where:

- ϵ_{uc} = factored compressive strain due to thrust
- ϵ_{sc} = service compressive strain due to thrust
- T_u = factored thrust per unit length (lb/in.)
- T_s = service thrust per unit length (lb/in.)
- A_{eff} = effective area of pipe wall per unit length of pipe (in.²/in.)
- E_p = short-term modulus for short-term loading or long-term modulus of pipe material for long-term loading as specified in Table 12.12.3.3-1 (ksi)
- D_o = outside diameter of pipe (in.)
- P_u = factored load as specified in Eq. 12.12.3.5-1

12.12.3.10.1d—Thrust Strain Limits

The factored compression strain due to thrust, ϵ_{uc} , shall satisfy:

$$\epsilon_{uc} \leq \phi_T \epsilon_{yc} \quad (12.12.3.10.1d-1)$$

where:

- ϵ_{uc} = factored compressive strain due to thrust
- ϕ_T = resistance factor for thrust effects
- ϵ_{yc} = factored compression strain limit of the pipe wall material as specified in Table 12.12.3.3-1

12.12.3.10.1e—General Buckling Strain Limits

C12.12.3.10.1e

The factored compression strain due to thrust, incorporating local buckling effects, ϵ_{uc} , shall satisfy:

$$\epsilon_{uc} \leq \phi_{bck} \epsilon_{bck} \quad (12.12.3.10.1e-1)$$

The equations for global resistance presented here are a conservative simplification of the continuum buckling theory presented by Moore (1990). Detailed analysis using the full theory may be applied in lieu of the calculations in this section.

The nominal strain capacity for general buckling of the pipe shall be determined as:

$$\epsilon_{bck} = \frac{1.2C_n (E_p I_p)^{\frac{1}{3}} \left[\frac{\phi_s M_s (1-2\nu)}{(1-\nu)^2} \right]^{\frac{2}{3}} R_h}{A_{eff} E_p} \quad (12.12.3.10.1e-2)$$

in which:

$$R_h = \frac{11.4}{11 + \frac{D}{12H}} \quad (12.12.3.10.1e-3)$$

where:

- ϵ_{uc} = factored compressive strain due to thrust
- ϕ_{bck} = resistance factor for global buckling
- ϵ_{bck} = nominal strain capacity for general buckling

R_h = correction factor for backfill soil geometry

The term ϕ_s appears in this expression for ϵ_{bck} to account for backfills compacted to levels below that specified in the design. Lower levels of compaction increases the thrust force in the pipe.

For designs meeting all other requirements of these specifications and the *AASHTO LRFD Bridge Construction Specifications*, the correction for backfill soil geometry, R_h , is equal to value at left.

The complete theory proposed by Moore (1990) provides variations in R_h that consider nonuniform backfill support. In the extreme case where the width of structural backfill at the side of the culvert is 0.1 times the span and the modulus of the soil outside of the structural backfill is 0.1 times the modulus of the backfill, then:

$$R_h = \frac{20}{56 + \frac{D}{12H}} \quad (C12.12.3.10.1e-1)$$

C_n = calibration factor to account for nonlinear effects
= 0.55

E_p = short- or long-term modulus of pipe material as specified in Table 12.12.3.3-1 (ksi)

I_p = moment of inertia of pipe profile per unit length of pipe (in.⁴/in.)

A_{eff} = effective area of pipe profile per unit length of pipe (in.²/in.)

ϕ_s = resistance factor for soil pressure

M_s = secant constrained soil modulus as specified in Table 12.12.3.5-1 (ksi)

ν = Poisson's ratio of soil

Poisson's ratio is used to convert the constrained modulus of elasticity to the plane strain modulus. Values for Poisson's ratio of soils are provided in many geotechnical references. One reference is Selig (1990).

D = diameter to centroid of pipe profile (in.)

H = depth of fill over top of pipe (ft)

12.12.3.10.2—Bending and Thrust Strain Limits

12.12.3.10.2a—General

To ensure adequate flexural capacity the combined strain at the extreme fibers of the pipe profile must be evaluated at the allowable deflection limits against the limiting strain values.

12.12.3.10.2b—Combined Strain

If summation of axial strain, ϵ_{uc} , and bending strain, ϵ_f , produces tensile strain in the pipe wall, the combined

C12.12.3.10.2b

The criteria for combined compressive strain are based on limiting local buckling. A higher strain limit is

strain at the extreme fiber where flexure causes tension shall satisfy:

$$\varepsilon_f - \varepsilon_{uc} < \phi_f \varepsilon_{yt} \quad (12.12.3.10.2b-1)$$

The combined strain at the extreme fiber where flexure causes compression shall satisfy:

$$\varepsilon_f + \varepsilon_{uc} < \phi_T 1.5\varepsilon_{yc} \quad (12.12.3.10.2b-2)$$

where:

- ε_f = factored strain due to flexure
- ε_{uc} = factored compressive strain due to thrust
- ε_{yt} = service long-term tension strain limit of the pipe wall material as specified in Table 12.12.3.3-1
- ϕ_f = resistance factor for flexure
- ϕ_T = resistance factor for thrust
- ε_{yc} = factored compression strain limit of the pipe wall material as specified in Table 12.12.3.3-1

In the absence of a more-detailed analysis, the flexural strain may be determined based on the empirical relationship between strain and deflection as:

$$\varepsilon_f = \gamma_{EV} D_f \left(\frac{c}{R} \right) \left(\frac{\Delta_f}{D} \right) \quad (12.12.3.10.2b-3)$$

in which:

$$\Delta_f = \Delta_A - \varepsilon_{sc} D \quad (12.12.3.10.2b-4)$$

where:

- ε_f = factored strain due to flexure
- ε_{sc} = service compression strain due to thrust
- Δ_f = reduction of vertical diameter due to flexure (in.)
- γ_{EV} = load factor for vertical pressure from dead load of earth fill, as specified in Article 3.4.1
- D_f = shape factor as specified in Table 12.12.3.10.2b-1. The shape factors for corrugated PE pipe can be reduced by 1.0 from the table values to account for the effect of the low hoop stiffness ratio.
- c = the larger of the distance from neutral axis of profile to the extreme innermost or outermost fiber (in.)
- R = radius from center of pipe to centroid of pipe profile (in.)
- D = diameter to centroid of pipe profile (in.)
- Δ_A = total allowable deflection of pipe, reduction of vertical diameter (in.)

allowed for combined strains because under bending, the web elements have a low stress near the centroid of the element and are thus unlikely to buckle. Thus the unbuckled web elements increase the stability of the crest and valley elements.

The strain limit for combined compression strain is 50 percent higher than that for hoop compression alone because the web elements, which experience low strains due to bending, are not likely to buckle, thus increasing the stability of elements near the crest and valley. While this behavior would be more accurately modeled as an increase in the k factor of Eq. 12.12.3.10.1b-4, the increase in the limiting strain is considered adequate for this simplified design method.

For thrust capacity, the section is limited by consideration of hoop compression capacity alone. The check of combined compression strain, hoop plus bending, is used to limit the allowable pipe deflection.

Elements subjected primarily to bending (such as a web element in Figure 12.12.3.10.1b-1 when the pipe is deflected) are not highly stressed near the centroid, where buckling initiates, and theoretical k factors for plates in bending are greater than 20. To simplify the analysis for combined bending and thrust, elements, such as the web whose centroid is within $c/3$ of the centroid of the entire profile wall, may be analyzed only for the effect of hoop compression strains. That is, increases in strain due to bending may be ignored.

Past practice has used tensile strain limits specified in Table 12.12.3.3-1, with no guidance on ultimate strain limits. For purposes of design calculations, assume that ultimate tensile strain capacity is 50 percent greater than the service capacities provided in Table 12.12.3.3-1.

A higher strain limit is allowed under combined bending and compression. This increase is permitted because the web element under flexure has a low stress at the center of the element, reducing the likelihood of buckling, and allowing it to provide more stability to the crest and valley elements.

Flexural strains are always taken as positive.

Peak flexural stress occurs near the crown for live load conditions and near the haunch/invert region for deep burial cases. The factors K_1 and K_2 should be used in the thrust computations to determine the thrust strains used in Eqs. 12.12.3.10.2b-1 and 12.12.3.10.2b-2.

The service compressive strain is used for determination of the factored strain due to flexure instead of the factored compressive strain. The use of the factored compressive strain would result in an unconservative flexural strain demand.

The empirical shape factor is used in the design of fiberglass pipe and is presented in AWWA Manual of Practice M45 Fiberglass Pipe Design (1996). It demonstrates that bending strains are highest in low

stiffness pipe backfilled in soils that require substantial compactive effort (silts and clays), and is lowest in high stiffness pipe backfilled in soils that require little compactive effort (sands and gravels).

Table 12.12.3.10.2b-1 does not cover all possible backfills and density levels. Designers should interpolate or extrapolate the Table as necessary for specific projects.

More detailed analyses must consider the likelihood of inconsistent soil support to the pipe in the haunch zone, and of local deformations during placement and compaction of backfill.

Bending strains typically cannot be accurately predicted during design due to variations in backfill materials and compactive effort used during installation. Installation deflection limits are specified in the construction specifications to assure that design parameters are not exceeded.

The deflection design limit is five percent reduction of the vertical diameter as specified in the construction specification. The pipe must be designed to permit this deflection, unless extraordinary measures are specified in contract documents to minimize compactive effort and to control deflections.

The *AASHTO Bridge Construction Specifications* currently restrict the allowable total vertical deflection to five percent.

Table 12.12.3.10.2b-1—Shape Factors, D_f , based on Pipe Stiffness, Backfill and Compaction Level

Pipe Stiffness (F/Δ_y , ksi) $= EI / 0.149 R^3$	Pipe Zone Embedment Material and Compaction Level			
	Gravel (1)		Sand (2)	
	Dumped to Slight (3)	Moderate to High (4)	Dumped to Slight (3)	Moderate to High (4)
0.009	5.5	7.0	6.0	8.0
0.018	4.5	5.5	5.0	6.5
0.036	3.8	4.5	4.0	5.5
0.072	3.3	3.8	3.5	4.5

1. GW, GP, GW-GC, GW-GM, GP-GC and GP-GM per ASTM D2487 (includes crushed rock)
2. SW, SP, SM, SC, GM and GC or mixtures per ASTM D2487
3. <85% of maximum dry density per AASHTO T 99, < 40% relative density (ASTM D4253 and D4254)
4. ≥85% of maximum dry density per AASHTO T 99, ≥ 40% relative density (ASTM D4253 and D4254)

12.12.4—Construction and Installation

The contract documents shall require that the construction and installation conform to Section 30, “Thermoplastic Culverts,” *AASHTO LRFD Bridge Construction Specifications*.

12.13—STEEL TUNNEL LINER PLATE**12.13.1—General**

The provisions of this Article shall apply to the structural design of steel tunnel liner plates. Construction shall conform to Section 25, “Steel and Concrete Tunnel Liners,” *AASHTO LRFD Bridge Construction Specifications*.

The tunnel liner plate may be two-flange, fully corrugated with lapped longitudinal seams or four-flange, partially corrugated with flanged longitudinal seams. Both types shall be bolted together to form annular rings.

12.13.2—Loading

The provisions for earth loads given in Article 3.11.5 shall not apply to tunnels.

12.13.2.1—Earth Loads

The provisions of Article 12.4.1 shall apply. When more refined methods of soil analysis are not employed, the earth pressure may be taken as:

$$W_E = C_{dt} \gamma_s S \quad (12.13.2.1-1)$$

where:

- C_{dt} = load coefficient for tunnel installation specified in Figure 12.13.2.1-1
- γ_s = total unit weight of soil (kcf)
- W_E = earth pressure at the crown (ksf)
- S = tunnel diameter or span (ft)

C12.13.1

The supporting capacity of a nonrigid tunnel lining, such as a steel liner plate, results from its ability to deflect under load, so that side restraint developed by the lateral resistance of the soil constrains further deflection. Thus, deflection tends to equalize radial pressures and to load the tunnel liner as a compression ring.

C12.13.2

The earth load to be carried by the tunnel liner is a function of the type of soil. In granular soil with little or no cohesion, the load is a function of the angle of internal friction of the soil and the diameter of the tunnel. In cohesive soils such as clays, the load to be carried by the tunnel liner is dependent on the shearing strength of the soil above the roof of the tunnel.

C12.13.2.1

Eq. 12.13.2.1-1 is a form of the Marston formula. It proportions the amount of total overburden pressure acting on the tunnel based on the internal friction angle of the soil to be tunneled.

In the absence of adequate borings and soil tests, use $\phi_f = 0$ when calculating W_E .

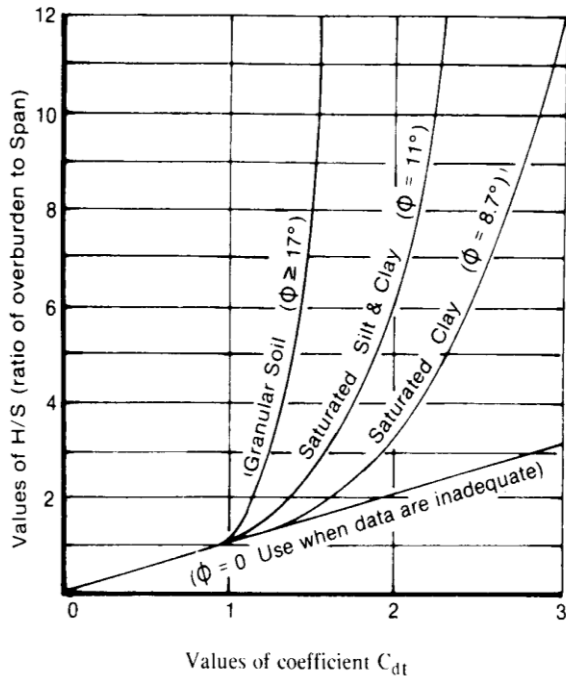

Figure 12.13.2.1-1—Diagram for Coefficient C_{dt} for Tunnel in Soil

in which:

H = height of soil over top of tunnel (ft)

12.13.2.2—Live Loads

The provisions of Article 12.6.1 shall apply.

12.13.2.3—Grouting Pressure

If the grouting pressure is greater than the computed design load, W_T , on the tunnel liner shall be the grouting pressure.

12.13.3—Safety against Structural Failure

12.13.3.1—Section Properties

Steel tunnel liner plate shall meet the minimum requirements of Table 12.13.3.1-1 for cross-sectional properties, Table 12.13.3.1-2 for seam strength, and Table 12.13.3.1-3 for mechanical properties.

12.13.3.2—Wall Area

The requirements of Articles 12.7.2.2 and 12.7.2.3 shall apply using effective area from Table 12.13.3.1-1.

12.13.3.3—Buckling

The requirements of Article 12.7.2.4 shall apply, except that the soil stiffness factor, k , may vary from 0.22 to 0.44 depending upon the quality and extent of the backpacking material used.

12.13.3.4—Seam Strength

The requirements of Article 12.7.2.5 shall apply.

12.13.3.5—Construction Stiffness

Construction stiffness shall be indicated by a construction stiffness factor as:

$$C_s = \frac{EI}{S^2} \quad (12.13.3.5-1)$$

where:

- S = diameter or span (in.)
- E = modulus of elasticity (ksi)
- I = moment of inertia (in.⁴/in.)

The value of C_s from Eq. 12.13.3.5-1 shall not be less than the values for steel tunnel liner plate as given in Article 12.5.6.4.

C12.13.3.3

Wall buckling is a function of the stiffness, k , of the surrounding soil bearing on the plates. Where portland cement grouting or quality backpacking (meeting the requirements of Section 25, “Steel and Concrete Tunnel Liners,” *AASHTO LRFD Bridge Construction Specifications*) material fill the void outside the plates, $k = 0.22$ is applicable. For other soils or in-situ backpacking material, $k = 0.44$ is suggested. Where tunneled soils slough or voids are left in the backpacking, additional consideration as to the value of k may be required.

C12.13.3.5

The liner plate ring should have sufficient rigidity to resist the unbalanced loads of normal construction from grouting, local slough-ins, and miscellaneous concentrated loads.

The minimum construction stiffness required for these loads, C_s , can be expressed for convenience by the formula below. It must be recognized, however, that the limiting values given here are only recommended minimums. Actual job conditions may require greater effective stiffness. Final determination of this factor should be based on intimate knowledge of the project and on practical experience.

The construction stiffness, C_s , given by Eq. 12.13.3.5-1, considers the moment of inertia of an individual plate.

Table 12.13.3.1-1—Cross-Sectional Properties—Steel Tunnel Liner Plate

2-Flange Tunnel Liner Plates				
Thickness (in.)		Effective Area (in. ² /in.)	Moment of Inertia (in. ⁴ /in.)	Radius of Gyration (in.)
0.075		0.096	0.034	0.595
0.105		0.135	0.049	0.602
0.135		0.174	0.064	0.606
0.164		0.213	0.079	0.609
0.179		0.233	0.087	0.611
0.209		0.272	0.103	0.615
0.239		0.312	0.118	0.615
4-Flange Tunnel Liner Plates				
Thickness (in.)	Area (in. ² /in.)	Effective Area (in. ² /in.)	Moment of Inertia (in. ⁴ /in.)	Radius of Gyration (in.)
0.1050	0.133	0.067	0.042	0.561
0.1196	0.152	0.076	0.049	0.567
0.1350	0.170	0.085	0.055	0.568
0.1640	0.209	0.105	0.070	0.578
0.1790	0.227	0.114	0.075	0.555
0.2090	0.264	0.132	0.087	0.574
0.2390	0.300	0.150	0.120	0.632
0.2500	0.309	0.155	0.101	0.571
0.3125	0.386	0.193	0.123	0.564
0.3750	0.460	0.230	0.143	0.557

Table 12.13.3.1-2—Minimum Longitudinal Seam Strength with Bolt and Nut Requirements for Steel Tunnel Plate Liner

Plate Thickness (in.)	2-Flange Plate			4-Flange Plate		
	Longitudinal Seam Bolts		Ultimate Seam Strength (kip/ft)	Longitudinal Seam Bolts		Ultimate Seam Strength (kip/ft)
	Diameter (in.)	Material ASTM		Diameter (in.)	Material ASTM	
0.075	0.625	A307	20	—	—	—
0.105	0.625	A307	30	0.500	A307	26
0.135	0.625	A307	47	0.500	A307	43
0.164	0.625	A307	55	0.500	A307	50
0.179	0.625	A307	62	0.625	A307	54
0.209	0.625	A449	87	0.625	A307	67
0.239	0.625	A449	92	0.625	A307	81
0.313	0.625	—	—	0.625	A307	115
0.375	0.625	—	—	0.625	A307	119

All nuts shall conform to ASTM A307, Grade A or better.

Circumferential seam bolts shall conform to ASTM A307 or better for all plate thicknesses.

Table 12.13.3.1-3—Mechanical Properties—Steel Tunnel Liner Plate (Plate before Cold Forming)

Minimum Tensile Strength	42.0 ksi
Minimum Yield Strength	28.0 ksi
Elongation, 2.0 in.	30%
Modulus of Elasticity	29,000 ksi

**12.14—PRECAST REINFORCED CONCRETE
THREE-SIDED STRUCTURES****12.14.1—General**

The provisions herein shall apply to the design of precast reinforced concrete three-sided structures supported on a concrete footing foundation.

12.14.2—Materials**12.14.2.1—Concrete**

Concrete shall conform to Article 5.4.2, except that evaluation of f'_c may also be based on cores.

12.14.2.2—Reinforcement

Reinforcement shall meet the requirements of Article 5.4.3, except that for welded wire fabric a yield strength of 65,000 psi may be used. For wire fabric, the spacing of longitudinal wires shall be a maximum of 8.0 in. Circumferential welded wire fabric spacing shall not be greater than 4.0 in. or less than 2.0 in. Prestressing, if used, shall be in accordance with Article 5.9.

12.14.3—Concrete Cover for Reinforcement

The minimum concrete cover for reinforcement in precast three-sided structures reinforced with welded wire fabric shall be taken as three times the wire diameter, but not less than 1.0 in., except for the reinforcement in the top of the top slab of structures covered by less than 2.0 ft of fill, in which case the minimum cover shall be taken as 2.0 in.

12.14.4—Geometric Properties

Except as noted herein, the shape of the precast three-sided structures may vary in span, rise, wall thickness, haunch dimensions, and curvature. Specific geometric properties shall be specified by the manufacturer. Wall thicknesses shall be a minimum of 8.0 in. for spans under 24.0 ft and 10.0 in. for 24.0 ft and larger spans.

12.14.5—Design**12.14.5.1—General**

Designs shall conform to applicable sections of these Specifications, except as provided otherwise herein. Analysis shall be based on a pinned connection at the footing and shall take into account anticipated footing movement.

C12.14.1

Units may be manufactured using conventional structural concrete and forms (formed) or machine made using dry concrete and vibrating forms.

12.14.5.2—Distribution of Concentrated Load Effects in Top Slab and Sides

Distribution of wheel loads and concentrated loads for the top slab and sides of three-sided structures shall be taken as specified in Article 12.11.2.1.

12.14.5.3—Distribution of Concentrated Loads in Skewed Culverts

Wheel loads on skewed culverts shall be distributed using the same provisions as given for culverts with main reinforcement parallel to traffic. For culvert elements with skews greater than 15 degrees, the effect of the skew shall be considered in analysis.

12.14.5.4—Shear Transfer in Transverse Joints between Culvert Sections

The provisions of Article 4.6.2.10.4 shall apply.

In addition, except as provided herein, a means of shear transfer between adjacent units shall be provided in the top slab of structures having flat tops under less than 2.0 ft of fill and subjected to vehicular live loads. Shear transfer between adjacent units may be considered adequate where the thickness of the top slab is equal to or greater than:

- For prestressed slabs:
 $S/28$ (12.14.5.4-1)
- For non-prestressed slabs:
 $(S + 10)/30$ (12.14.5.4-2)

where:

S = clear span (ft) measured parallel to the joint with the adjacent section

C12.14.5.4

Flat top structures with less than 2.0 ft of fill and with top slabs that are thinner than specified in this Article may experience differential deflection of adjacent units which can cause pavement cracking if a means of shear transfer is not utilized.

The specified minimum slab thickness and span to slab thickness ratios reflect years of experience in the design and construction of flat top three-sided structures and are influenced by Table 9.5(a) of ACI 318-08 and Table 8.9.2 of the *AASHTO Standard Specifications for Highway Bridges*, 17th Edition. Past performance of flat top three-sided structures designed in accordance with these provisions provides additional support for this exception.

For skewed sections, design is based on the span measured parallel to the joint with the adjacent section. This is a longer span than measured perpendicular to the end walls. However, designing for a longer span provides additional reinforcement to address the non-uniform stresses introduced by the skewed geometry which are not explicitly considered for modest skew angles.

Arch-top structures, because of their geometry and interaction with the surrounding soil, do not exhibit significant differential deflections that could cause pavement cracking for structures with less than 2.0 ft of fill. Thus, the requirements of this Article do not apply to arch-top structures.

The minimum thickness provision of this Section pertains only to addressing the need for shear transfer between adjacent three-sided sections. All other provisions of this Specification must be met.

12.14.5.5—Span Length

When monolithic haunches inclined at 45 degrees are taken into account, negative reinforcement in walls and slabs may be proportioned on the basis of bending moment at the intersection of the haunch and uniform depth member.

12.14.5.6—Resistance Factors

The provisions of Articles 5.5.4.2 and 1.3.1 shall apply as appropriate.

12.14.5.7—Crack Control

The provisions of Article 5.7.3.4 for buried structures shall apply.

12.14.5.8—Minimum Reinforcement

The provisions of Article 5.10.8 shall not be taken to apply to precast three-sided structures.

The primary flexural reinforcement in the direction of the span shall provide a ratio of reinforcement area to gross concrete area at least equal to 0.002. Such minimum reinforcement shall be provided at all cross-sections subject to flexural tension, at the inside face of walls, and in each direction at the top of slabs of three-sided sections with less than 2.0 ft of fill.

12.14.5.9—Deflection Control at the Service Limit State

The deflection limits for concrete structures specified in Article 2.5.2.6.2 shall be taken as mandatory and pedestrian usage as limited to urban areas.

12.14.5.10—Footing Design

Design shall include consideration of differential horizontal and vertical movements and footing rotations. Footing design shall conform to the applicable Articles in Sections 5 and 10.

12.14.5.11—Structural Backfill

Specification of backfill requirements shall be consistent with the design assumptions used. The contract documents should require that a minimum backfill compaction of 90 percent Standard Proctor Density be achieved to prevent roadway settlement adjacent to the structure. A higher backfill compaction density may be required on structures utilizing a soil-structure interaction system.

12.14.5.12—Scour Protection and Waterway Considerations

The provisions of Article 2.6 shall apply as appropriate.

12.15—REFERENCES

- AA. 1983. *Aluminum Drainage Products Manual*, 1st Edition. Aluminum Association, Washington, DC, p. 86.
- AASHTO. 2010. *AASHTO LRFD Bridge Construction Specifications*, Third Edition, LRFDCONS-3. American Association of State Highway and Transportation Officials, Washington, DC. Pending.
- AASHTO. 2011. *Standard Specifications for Transportation Materials and Methods of Sampling and Testing*, 31st Edition, HM-31, American Association of State Highway and Transportation Officials, Washington, DC. Includes AASHTO M, R, and T standards, which are also available individually in downloadable form.
- Abolmaali, I., I. Garg, et al. 2007. "Experimental and Finite Element Based Investigations of Shear Behavior in Reinforced Concrete Box Culverts," *Journal Title*. Publisher, Locale, Vol. X, No. Y.
- AWWA. 1996. "Fiberglass Pipe Design." *AWWA Manual of Water Supply Practice M45*. American Water Works Association, Denver, CO.
- Bellair, P. J., and J. P. Ewing. 1984. *Metal Loss Rates of Uncoated Steel and Aluminum Culverts in New York*, Research Report 115. Engineering Research and Development Bureau, New York State Department of Transportation, Albany, NY.
- Boulanger, R. W., R. B. Seed, R. D. Baird, and J. C. Schluter. 1989. "Measurements and Analyses of Deformed Flexible Box Culverts." *Transportation Research Record 1231*. Transportation Research Board, National Research Council, Washington, DC, pp. 25–35.
- Burns, J. Q., and R. M. Richard. 1964. "Attenuation of Stresses for Buried Cylinders." *Proceedings of the Conference on Soil Structure Interaction*. University of Arizona, Tucson, AZ, pp. 378–392.
- CSA. 2006. *Canadian Highway Bridge Design Code*, CAN/CSA-S6-06. Canadian Standards Association, Rexdale, ON, Canada.
- Duncan, J. M., R. B. Seed, and R. H. Drawsky. 1985. "Design of Corrugated Metal Box Culverts." *Transportation Research Record 1008*. Transportation Research Board, National Research Council, Washington, DC, pp. 33–41.
- Frederick, G. R., C. V. Ardis, K. M. Tarhini, and B. Koo. 1988. "Investigation of the Structural Adequacy of C 850 Box Culverts." *Transportation Research Record 1191*. Transportation Research Board, National Research Council, Washington, DC.
- Funahashi, M., and J. B. Bushman. 1991. "Technical Review of 100 mV Polarization Shift Criterion for Reinforcing Steel in Concrete." *Corrosion*, Vol. 47, No. 5, May 1991, pp. 376–386.
- Hashash, N., and E. T. Selig. 1990. "Analysis of the Performance of a Buried High Density Polyethylene Pipe." *Proceedings of the First National Conference on Flexible Pipes*. Columbus, OH, October 1990, pp. 95–103.
- Hurd, J. O. 1984. "Field Performance of Concrete Pipe and Corrugated Steel Pipe Culverts and Bituminous Protection of Corrugated and Steel Pipe Culverts." *Transportation Research Record 1001*. Transportation Research Board, National Research Council, Washington, DC, pp. 40–48.
- FHWA. 1985. *Hydraulic Design of Highway Culverts*, FHWA-IP-85-15. Federal Highway Administration, U.S. Department of Transportation, Washington, DC, Hydraulic Design Series No. 5, p. 272.
- James, R. W. 1984. "Behavior of ASTM C 850 Concrete Box Culverts Without Shear Connectors." *Transportation Research Record 1001*. Transportation Research Board, National Research Council, Washington, DC.
- Koepf, A. H., and P. H. Ryan. 1986. "Abrasion Resistance of Aluminum Culvert Based on Long-Term Field Performance." *Transportation Research Record 1087*. Transportation Research Board, National Research Council, Washington, DC, pp. 15–25.

- McGrath, T. J. 1996. *A Proposed Design Method for Calculating Loads and Hoop Compression Stresses for Buried Pipe*. Draft report submitted to the Polyethylene Pipe Design Task Group of the AASHTO Flexible Culvert Liaison Committee.
- McGrath, T. J. 1999. "Calculating Loads on Buried Culverts Based on Pipe Hoop Stiffness." *Transportation Research Record 1656*. Transportation Research Board, National Research Council, Washington, DC.
- McGrath, T. J. 2004. "Live Load Distribution Widths for Reinforced Concrete Box Culverts," *Journal Title*. Publisher, Locale, Vol. X, No. Y.
- McGrath, T. J. 2005. *Structural Investigation of Metal Box Section with Spans up to 36 ft* Prepared for CONTECH Construction Products, Inc. by Simpson Gumpertz & Heger, Inc. Waltham, MA.
- McGrath, T. J., A. A. Liepins, J. L. Beaver, and B.P. Strohmman. 2004. *Live Load Distribution Widths for Reinforced Concrete Box Culverts*. A study for the Pennsylvania Department of Transportation conducted by Simpson Gumpertz and Heger, Inc., Waltham, MA.
- McGrath, T. J., I. D. Moore, E. T. Selig, M. C. Webb, and B. Taleb. 2002. *Recommended Specifications for Large-Span Culverts*, NCHRP Report 473. Transportation Research Board, National Research Council, Washington, DC.
- McGrath, T. J., I. D. Moore, and G. Y. Hsuan. 2009. *Updated Test and Design Methods for Thermoplastic Drainage Pipe*, NCHRP Report 631. National Cooperative Highway Research Program, Transportation Research Board, National Research Council, Washington, DC.
- McGrath, T. J., and J. L. Beaver. 2005. *Performance of Thermoplastic Pipe under Highway Vehicle Loading*, Simpson Gumpertz & Heger Inc., Oakdale, MN. Research Report to Minnesota Department of Transportation.
- McGrath, T. J., and V. E. Sagan. 1999. *LRFD Specifications for Plastic Pipe and Culverts*, NCHRP Report 438. Transportation Research Board, National Research Council, Washington, DC.
- Meacham, D. G., J. O. Hurd, and W. W. Shislar. 1982. *Culvert Durability Study*, Report No. ODOT/LandD/82-1. Ohio Department of Transportation, Columbus, OH.
- Moore, I. D. 1990. "Three-Dimensional Response of Elastic Tubes," *International Journal of Solids and Structures*. Elsevier, Maryland Heights, MO, Vol. 26, No. 4.
- Moore, I. D. 1995. "Three-Dimensional Response of Deeply Buried Profiled Polyethylene Pipe." *Transportation Research Record 1514*. Transportation Research Board, National Research Council, Washington, DC, pp. 49–58.
- NRC. 1978. "Durability of Drainage Pipe." *NCHRP Synthesis of Highway Practice No. 50*. Transportation Research Board, National Research Council, Washington, DC, p. 37.
- Potter, J. C. 1988. *Life Cycle Cost for Drainage Structures*, Technical Report GL-88-2. Prepared for the Department of the Army by the Waterways Experiment Station, Vicksburg, MS, p. 72.
- Selig, E.T. 1990. "Soil Properties for Plastic Pipe Installation," *Buried Plastic Pipe Technology*, ASTM STP 1093, George S. Buczala and Michael J. Cassady, eds. American Society for Testing and Materials, Philadelphia, PA.
- White, D. W., and M. J. Clarke. 1997. "Design of Beam-Columns in Steel Frames II: Comparison of Standards," *Journal of Structural Engineering*. American Society of Civil Engineers, Reston, VA, Vol. 123, No. 12.

APPENDIX A12—PLATE, PIPE, AND PIPE ARCH PROPERTIES

Table A12-1—Corrugated Steel Pipe—Cross-Section Properties

1 1/2 × 1/4 in. Corrugation			
Thickness (in.)	A (in. ² /ft)	r (in.)	$I \times 10^{-3}$ (in. ⁴ /in.)
0.028	0.304	—	—
0.034	0.380	—	—
0.040	0.456	0.0816	0.253
0.052	0.608	0.0824	0.344
0.064	0.761	0.0832	0.439
0.079	0.950	0.0846	0.567
0.109	1.331	0.0879	0.857
0.138	1.712	0.0919	1.205
0.168	2.098	0.0967	1.635

2 2/3 × 1/2 in. Corrugation			
Thickness (in.)	A (in. ² /ft)	r (in.)	$I \times 10^{-3}$ (in. ⁴ /in.)
0.040	0.465	0.1702	1.121
0.052	0.619	0.1707	1.500
0.064	0.775	0.1712	1.892
0.079	0.968	0.1721	2.392
0.109	1.356	0.1741	3.425
0.138	1.744	0.1766	4.533
0.168	2.133	0.1795	5.725

3 × 1 in. Corrugation			
Thickness (in.)	A (in. ² /ft)	r (in.)	$I \times 10^{-3}$ (in. ⁴ /in.)
0.064	0.890	0.3417	8.659
0.079	1.113	0.3427	10.883
0.109	1.560	0.3448	15.459
0.138	2.008	0.3472	20.183
0.168	2.458	0.3499	25.091

5 × 1 in. Corrugation			
Thickness (in.)	A (in. ² /ft)	r (in.)	$I \times 10^{-3}$ (in. ⁴ /in.)
0.064	0.794	0.3657	8.850
0.079	0.992	0.3663	11.092
0.109	1.390	0.3677	15.650
0.138	1.788	0.3693	20.317
0.168	2.186	0.3711	25.092

Table A12-2—Spiral Rib Steel Pipe—Cross-Section Properties

3/4 × 3/4 × 7 1/2 in. Corrugation			
Thickness (in.)	A (in. ² /ft)	r (in.)	$I \times 10^{-3}$ (in. ⁴ /in.)
0.064	0.509	0.258	2.821
0.079	0.712	0.250	3.701
0.109	1.184	0.237	5.537
0.138	1.717	0.228	7.433

3/4 × 1 × 11 1/2 in. Corrugation			
Thickness (in.)	A (in. ² /ft)	r (in.)	$I \times 10^{-3}$ (in. ⁴ /in.)
0.064	0.374	0.383	4.58
0.079	0.524	0.373	6.08
0.109	0.883	0.355	9.26

Note: Effective section properties are taken at full yield stress.

Table A12-3—Steel Structural Plate—Cross-Section Properties

6 × 2 in. Corrugations			
Thickness (in.)	A (in. ²)	r (in.)	I (in. ⁴ /in. × 10 ⁻³)
0.110	1.556	0.682	60.4
0.140	2.003	0.684	78.2
0.170	2.449	0.686	96.2
0.188	2.739	0.688	108.0
0.218	3.199	0.690	126.9
0.249	3.650	0.692	146.2
0.280	4.119	0.695	165.8
0.318	4.671	0.698	190.0
0.380	5.613	0.704	232.0

Table A12-4—Corrugated Aluminum Pipe—Cross-Section Properties

1 1/2 × 1/4 in. Corrugation			
Thickness (in.)	A (in. ² /ft)	r (in.)	$I \times 10^{-3}$ (in. ⁴ /in.)
0.048	0.608	0.0824	0.344
0.060	0.761	0.0832	0.349

2 2/3 × 1/2 in. Corrugation			
Thickness (in.)	A (in. ² /ft)	r (in.)	$I \times 10^{-3}$ (in. ⁴ /in.)
0.060	0.775	0.1712	1.892
0.075	0.968	0.1721	2.392
0.105	1.356	0.1741	3.425
0.135	1.745	0.1766	4.533
0.164	2.130	0.1795	5.725

Table A12-4—Corrugated Aluminum Pipe—Cross-Section Properties (continued)

3 × 1 in. Corrugation			
Thickness (in.)	A (in. ² /ft)	r (in.)	$I \times 10^{-3}$ (in. ⁴ /in.)
0.060	0.890	0.3417	8.659
0.075	1.118	0.3427	10.883
0.105	1.560	0.3448	15.459
0.135	2.088	0.3472	20.183
0.164	2.458	0.3499	25.091

6 × 1 in. Corrugation			
Effective Thickness (in.)	A (in. ² /ft)	Effective Area (in. ² /ft)	r (in.)
0.060	0.775	0.387	0.3629
0.075	0.968	0.484	0.3630
0.105	1.356	0.678	0.3636
0.135	1.744	0.872	0.3646
0.164	2.133	1.066	0.3656

Table A12-5—Aluminum Spiral Rib Pipe—Cross-Section Properties

3/4 × 3/4 × 7 1/2 in. Corrugation			
Thickness (in.)	A (in. ² /ft)	r (in.)	$I \times 10^{-3}$ (in. ⁴ /in.)
0.060	0.415	0.272	2.558
0.075	0.569	0.267	3.372
0.105	0.914	0.258	5.073
0.135	1.290	0.252	6.826

3/4 × 1 × 11 1/2 in. Corrugation			
Thickness (in.)	A (in. ² /ft)	r (in.)	$I \times 10^{-3}$ (in. ⁴ /in.)
0.060	0.312	0.396	4.08
0.075	0.427	0.391	5.45
0.105	0.697	0.380	8.39
0.135	1.009	0.369	11.48

Note: Effective section properties are taken at full yield stress.

Table A12-6—Corrugated Aluminum Structural Plate or Pipe Arch—Cross-Section Properties

9 × 2 1/2 in. Corrugations			
Thickness (in.)	A (in. ² /ft)	r (in.)	I (in. ⁴ /in. × 10 ⁻³)
0.100	1.404	0.8438	83.1
0.125	1.750	0.8444	104.0
0.150	2.100	0.8449	124.9
0.175	2.449	0.8454	145.9
0.200	2.799	0.8460	167.0
0.225	3.149	0.8468	188.2
0.250	3.501	0.8473	209.4

Table A12-7—Minimum Longitudinal Seam Strength Corrugated Aluminum and Steel Pipe—Riveted or Spot Welded

2 × 1/2 and 2 2/3 × 1/2 in. Corrugated Aluminum Pipe			
Thickness (in.)	Rivet Size (in.)	Single Rivets (kip/ft)	Double Rivets (kip/ft)
0.060	5/16	9.0	14.0
0.075	5/16	9.0	18.0
0.105	3/8	15.6	31.5
0.135	3/8	16.2	33.0
0.164	3/8	16.8	34.0

3 × 1 in. Corrugated Aluminum Pipe		
Thickness (in.)	Rivet Size (in.)	Double Rivets (kip/ft)
0.060	3/8	16.5
0.075	3/8	20.5
0.105	1/2	28.0
0.135	1/2	42.0
0.164	1/2	54.5

6 × 1 in. Corrugated Aluminum Pipe		
Thickness (in.)	Rivet Size (in.)	Double Rivets (kip/ft)
0.060	1/2	16.0
0.075	1/2	19.9
0.105	1/2	27.9
0.135	1/2	35.9
0.167	1/2	43.5

2 × 1/2 and 2 2/3 × 1/2 in. Corrugated Steel Pipe			
Thickness (in.)	Rivet Size (in.)	Single Rivets (kip/ft)	Double Rivets (kip/ft)
0.064	5/16	16.7	21.6
0.079	5/16	18.2	29.8
0.109	3/8	23.4	46.8
0.138	3/8	24.5	49.0
0.168	3/8	25.6	51.3

3 × 1 in. Corrugated Steel Pipe		
Thickness (in.)	Rivet Size (in.)	Double Rivets (kip/ft)
0.064	3/8	28.7
0.079	3/8	35.7
0.109	7/16	53.0
0.138	7/16	63.7
0.168	7/16	70.7

Table A12-8—Minimum Longitudinal Seam Strengths Steel and Aluminum Structural Plate Pipe—Bolted

6 × 2 in. Steel Structural Plate Pipe				
Bolt Thickness (in.)	Bolt Diameter (in.)	4 Bolts/ft (kip/ft)	6 Bolts/ft (kip/ft)	8 Bolts/ft (kip/ft)
0.109	3/4	43.0	—	—
0.138	3/4	62.0	—	—
0.168	3/4	81.0	—	—
0.188	3/4	93.0	—	—
0.218	3/4	112.0	—	—
0.249	3/4	132.0	—	—
0.280	3/4	144.0	180.0	194.0
0.318	7/8	—	—	235.0
0.380	7/8	—	—	285.0

9 × 2 1/2 in. Aluminum Structural Plate Pipe			
Thickness (in.)	Bolt Diameter (in.)	Steel Bolts 5.5 Bolts per ft (kip/ft)	Aluminum Bolts 5.5 Bolts per ft (kip/ft)
0.100	3/4	28.0	26.4
0.125	3/4	41.0	34.8
0.150	3/4	54.1	44.4
0.175	3/4	63.7	52.8
0.200	3/4	73.4	52.8
0.225	3/4	83.2	52.8
0.250	3/4	93.1	52.8

Table A12-9—Mechanical Properties for Spiral Rib and Corrugated Metal Pipe and Pipe Arch

Material	Minimum Tensile Strength, F_u (ksi)	Minimum Yield Stress, F_y (ksi)	Modulus of Elasticity, E_m (ksi)
Aluminum H34 ^{(1)&(4)}	31.0	24.0	10,000
Aluminum H32 ^{(2)&(4)}	27.0	20.0	10,000
Steel ⁽³⁾	45.0	33.0	29,000

1. Shall meet the requirements of AASHTO M 197 (ASTM B744), for Alclad Alloy 3004-H34
2. Shall meet the requirements of AASHTO M 197 (ASTM B744), for Alclad Alloy 3004-H32
3. Shall meet the requirements of AASHTO M 167M/M 167 (ASTM A761/A761M), M 218, and M 246 (ASTM A742)
4. H34 temper material shall be used with riveted pipe to achieve seam strength. Both H32 and H34 temper material may be used with helical pipe

Table A12-10—Mechanical Properties—Corrugated Aluminum and Steel Plate

Material	Minimum Tensile Strength (ksi)	Minimum Yield Stress (ksi)	Modulus of Elasticity (ksi)
Aluminum ⁽¹⁾ Plate Thickness (in.)			
0.100–0.175	35.0	24.0	10,000
0.176–0.250	34.0	24.0	10,000
Steel ⁽²⁾ Plate Thickness (in.)			
All	45.0	33.0	29,000
Steel Deep Corrugated Plate	55.0	44.0	29,000

1. Shall meet the requirements of AASHTO M 219 (ASTM B746), Alloy 5052
2. Shall meet the requirements of AASHTO M 167M/M 167 (ASTM A761/A761M)

Table A12-11—PE Corrugated Pipes (AASHTO M 294)

Nominal Size (in.)	Min. <i>ID</i> (in.)	Max. <i>OD</i> (in.)	Min. <i>A</i> (in. ² /ft)	Min. <i>c</i> (in.)	Min. <i>I</i> (in. ⁴ /in.)
12	11.8	14.7	1.5	0.35	0.024
15	14.8	18.0	1.9	0.45	0.053
18	17.7	21.5	2.3	0.50	0.062
24	23.6	28.7	3.1	0.65	0.116
30	29.5	36.4	3.9	0.75	0.163
36	35.5	42.5	4.5	0.90	0.222
42*	41.5	48.0	4.69	1.11	0.543
48*	47.5	55.0	5.15	1.15	0.543

For the 42.0-in. and 48.0-in. pipe, the wall thickness should be designed using the long-term tensile strength provision, i.e., 900 psi, until new design criteria are established in the AASHTO bridge and structures specifications.

Table A12-12—PE Ribbed Pipes (ASTM F894)

Nominal Size (in.)	Min. <i>ID</i> (in.)	Max. <i>OD</i> (in.)	Min. <i>A</i> (in. ² /ft)	Min. <i>c</i> (in.)	Min. <i>I</i> (in. ⁴ /in.)	
					Cell Class 334433C	Cell Class 335434C
18	17.8	21.0	2.96	0.344	0.052	0.038
21	20.8	24.2	4.15	0.409	0.070	0.051
24	23.8	27.2	4.66	0.429	0.081	0.059
27	26.75	30.3	5.91	0.520	0.125	0.091
30	29.75	33.5	5.91	0.520	0.125	0.091
33	32.75	37.2	6.99	0.594	0.161	0.132
36	35.75	40.3	8.08	0.640	0.202	0.165
42	41.75	47.1	7.81	0.714	0.277	0.227
48	47.75	53.1	8.82	0.786	0.338	0.277

Table A12-13—PVC Profile Wall Pipes (AASHTO M 304)

Nominal Size (in.)	Min. I.D. (in.)	Max. O.D. (in.)	Min. A (in. ² /ft)	Min. c (in.)	Min. I (in. ⁴ /in.)	
					Cell Class 12454C	Cell Class 12364C
12	11.7	13.6	1.20	0.15	0.004	0.003
15	14.3	16.5	1.30	0.17	0.006	0.005
18	17.5	20.0	1.60	0.18	0.009	0.008
21	20.6	23.0	1.80	0.21	0.012	0.011
24	23.4	26.0	1.95	0.23	0.016	0.015
30	29.4	32.8	2.30	0.27	0.024	0.020
36	35.3	39.5	2.60	0.31	0.035	0.031
42	41.3	46.0	2.90	0.34	0.047	0.043
48	47.3	52.0	3.16	0.37	0.061	0.056

Table A12-14—Steel Structural Plate with Deep Corrugations—Cross Properties

15 × 5 1/2 in. Corrugations			
Coating Thickness (in.)	A (in. ² /ft)	r (in.)	I (in. ⁴ /in.)
0.140	2.26	1.948	0.714
0.170	2.762	1.949	0.875
0.188	3.088	1.950	0.979
0.218	3.604	1.952	1.144
0.249	4.118	1.953	1.308
0.280	4.633	1.954	1.472

Table A12-15—Minimum Longitudinal Seam Strengths, Deep Corrugated Structures—Bolted

15 × 5 1/2 in. Corrugations		
Coating Thickness (in.)	Bolt Diameter (in.)	6 Bolts/Corrugation (lb/ft of seam)
0.140	3/4	66 000
0.170	3/4	87 000
0.188	3/4	102 000
0.218	3/4	127 000
0.249	3/4	144 000
0.280	3/4	144 000
0.249	7/8	159 000
0.280	7/8	177 000

SECTION 13: RAILINGS

TABLE OF CONTENTS

13.1—SCOPE 13-1

13.2—DEFINITIONS 13-1

13.3—NOTATION 13-2

13.4—GENERAL 13-3

13.5—MATERIALS 13-5

13.6—LIMIT STATES AND RESISTANCE FACTORS 13-5

 13.6.1—Strength Limit State 13-5

 13.6.2—Extreme Event Limit State 13-5

13.7—TRAFFIC RAILING 13-5

 13.7.1—Railing System 13-5

 13.7.1.1—General 13-5

 13.7.1.2—Approach Railings 13-6

 13.7.1.3—End Treatment 13-6

 13.7.2—Test Level Selection Criteria 13-7

 13.7.3—Railing Design 13-8

 13.7.3.1—General 13-8

 13.7.3.1.1—Application of Previously Tested Systems 13-8

 13.7.3.1.2—New Systems 13-9

 13.7.3.2—Height of Traffic Parapet or Railing 13-9

13.8—PEDESTRIAN RAILING 13-9

 13.8.1—Geometry 13-9

 13.8.2—Design Live Loads 13-10

13.9—BICYCLE RAILINGS 13-11

 13.9.1—General 13-11

 13.9.2—Geometry 13-11

 13.9.3—Design Live Loads 13-11

13.10—COMBINATION RAILINGS 13-12

 13.10.1—General 13-12

 13.10.2—Geometry 13-12

 13.10.3—Design Live Loads 13-12

13.11—CURBS AND SIDEWALKS 13-12

 13.11.1—General 13-12

 13.11.2—Sidewalks 13-13

 13.11.3—End Treatment of Separation Railing 13-13

13.12—REFERENCES 13-13

APPENDIX A13—RAILINGS 13-15

A13.1—GEOMETRY AND ANCHORAGES	13-15
A13.1.1—Separation of Rail Elements	13-15
A13.1.2—Anchorage.....	13-17
A13.2—TRAFFIC RAILING DESIGN FORCES	13-17
A13.3—DESIGN PROCEDURE FOR RAILING TEST SPECIMENS.....	13-19
A13.3.1—Concrete Railings	13-19
A13.3.2—Post-and-Beam Railings	13-21
A13.3.3—Concrete Parapet and Metal Rail	13-22
A13.3.4—Wood Barriers	13-24
A13.4—DECK OVERHANG DESIGN	13-25
A13.4.1—Design Cases	13-25
A13.4.2—Decks Supporting Concrete Parapet Railings.....	13-25
A13.4.3—Decks Supporting Post-and-Beam Railings.....	13-26
A13.4.3.1—Overhang Design.....	13-26
A13.4.3.2—Resistance to Punching Shear.....	13-27

SECTION 13

RAILINGS

13.1—SCOPE

This Section applies to railings for new bridges and for rehabilitated bridges to the extent that railing replacement is determined to be appropriate.

This Section provides six bridge railing test levels and their associated crash test requirements. Guidance for determining the level to meet the warrants for the more common types of bridge sites and guidance for structural and geometric design of railings are provided.

A process for the design of crash test specimens to determine their crashworthiness is described in Appendix A13. This methodology is based on an application of the yield line theory. For use beyond the design of test specimens with expected failure modes similar to those shown in Figures CA13.3.1-1 and CA13.3.1-2, a rigorous yield line solution or a finite element solution should be developed. The procedures of Appendix A13 are not applicable to traffic railings mounted on rigid structures, such as retaining walls or spread footings, when the cracking pattern is expected to extend to the supporting components.

13.2—DEFINITIONS

Agency—A responsible business or service authorized to act on behalf of others, i.e., a governmental department, consulting engineering firm, or owner of the facility or feature.

Barrier Curb—A platform or block used to separate a raised pedestrian and/or bicycle sidewalk above the roadway level; see Figure 13.7.1.1-1.

Bicycle Railing—A railing or fencing system, as illustrated in Figure 13.9.3-1, that provides a physical guide for bicyclists crossing bridges to minimize the likelihood of a bicyclist falling over the system.

Bridge Approach Railing—A roadside guardrail system preceding the structure and attached to the bridge rail system that is intended to prevent a vehicle from impacting the end of the bridge railing or parapet.

Combination Railing—A bicycle or pedestrian railing system, as illustrated in Figures 13.8.2-1 and 13.9.3-1, added to a crashworthy bridge vehicular railing or barrier system.

Concrete Barrier—A railing system of reinforced concrete having a traffic face that usually but not always adopts some form of a safety shape.

Concrete Parapet—A railing system of reinforced concrete, usually considered an adequately reinforced concrete wall.

Crash Testing of Bridge Railings—Conducting a series of full-scale impact tests of a bridge railing in accordance with the recommended guidelines in NCHRP Report 350 or AASHTO's *Manual for Assessing Safety Hardware* in order to evaluate the railing's strength and safety performance.

Crashworthy—A system that has been successfully crash-tested to a currently acceptable crash test matrix and test level or one that can be geometrically and structurally evaluated as equal to a crash-tested system.

C13.1

All bridge traffic barrier systems will be referred to as railings herein.

The bridge railing performance need not be identical over the whole highway network. New railing designs should match site needs leading to a multiple test level concept, as described in NCHRP Report 350 or AASHTO's *Manual for Assessing Safety Hardware*.

All highway safety hardware accepted prior to the adoption of AASHTO, *Manual for Assessing Safety Hardware* (MASH), using criteria contained in NCHRP Report 350, may remain in place and may continue to be manufactured and installed. Highway safety hardware accepted using NCHRP Report 350 criteria is not required to be retested using MASH criteria. New highway safety hardware not previously evaluated must utilize MASH for testing and evaluation.

With the finite resources available to bridge owners, it is not reasonable to expect all existing rails to be updated any more than to expect every existing building to be immediately updated with the passing of a new building code. Many existing bridge rails have proven functional and need only be replaced when removed for bridge widenings.

Design Force—An equivalent static force that represents the dynamic force imparted to a railing system by a specified vehicle impacting a railing at a designated speed and angle.

Encroachment—An intrusion into prescribed, restrictive, or limited areas of a highway system, such as crossing a traffic lane or impacting a barrier system. Also, the occupancy of highway right-of-way by nonhighway structures or objects of any kind or character.

End Zone—The area adjacent to any open joint in a concrete railing system that requires added reinforcement.

Expressway—A controlled access arterial highway that may or may not be divided or have grade separations at intersections.

Face of the Curb—The vertical or sloping surface on the roadway side of the curb.

Freeway—A controlled access divided arterial highway with grade separations at intersections.

Longitudinal Loads—Horizontal design forces that are applied parallel to the railing or barrier system and that result from friction on the transverse loads.

Multiple Use Railing—Railing that may be used either with or without a raised sidewalk.

Owner—An authority or governmental department representing investors and/or taxpayers that is responsible for all the safety design features and functions of a bridge.

Pedestrian Railing—A railing or fencing system, as illustrated in Figure 13.8.2-1, providing a physical guidance for pedestrians across a bridge so as to minimize the likelihood of a pedestrian falling over the system.

Post—A vertical or sloping support member of a rail system that anchors a railing element to the deck.

Rail Element—Any component that makes up a railing system. It usually pertains to a longitudinal member of the railing.

Severity—A characterization of the degree of an event. It is usually associated with characterizing accidents as fatal, injury, or property damage only so that a dollar value can be assessed for economic study. It may also pertain to indexing the intensity of an accident so that a railing system can be assessed as a preventive or safety measure.

Speeds—Low/High—Vehicle velocities in mph. Low speeds are usually associated with city or rural travel where speeds are well posted and are under 45 mph. High speeds are usually associated with expressways or freeways where posted speeds are 45 mph or more.

Traffic Railing—Synonymous with vehicular railing; used as a bridge or structure-mounted railing, rather than a guardrail or median barrier as in other publications.

Transverse Loads—Horizontal design forces that are applied perpendicular to a railing or barrier system.

Vehicle Rollover—A term used to describe an accident in which a vehicle rotates at least 90° about its longitudinal axis after contacting a railing. This term is used if the vehicle rolls over as a result of contacting a barrier and not another vehicle.

Warrants—A document that provides guidance to the Designer in evaluating the potential safety and operational benefits of traffic control devices or features. Warrants are not absolute requirements; rather, they are a means of conveying concern over a potential traffic hazard.

13.3—NOTATION

A_f	=	area of post compression flange (in. ²) (A13.4.3.2)
B	=	out-to-out wheel spacing on an axle (ft); distance between centroids of tensile and compressive stress resultants in post (in.) (A13.2) (A13.4.3.2)
b	=	length of deck resisting post strength or shear load = $h + W_b$ (A13.4.3.2)

C	=	vertical post capacity or compression flange resistance of post in bending (kip-ft) (CA13.4.3.2)
d_b	=	distance from the outer edge of the base plate to the innermost row of bolts (in.) (A13.4.3.1)
E	=	distance from edge of slab to centroid of compressive stress resultant in post (in.) (A13.4.3.2)
F_L	=	longitudinal friction force along rail = $0.33 F_t$ (kips) (A13.2)
F_t	=	transverse vehicle impact force distributed over a length L_t at a height H_e above bridge deck (kips) (A13.2)
F_v	=	vertical force of vehicle laying on top of rail (kips) (A13.2)
f'_c	=	28-day compressive strength of concrete (ksi) (A13.4.3.2)
G	=	height of vehicle center of gravity above bridge deck (in.) (A13.2)
H	=	height of wall (ft) (A13.3.1)
H_R	=	height of rail (ft) (13.4)
H_w	=	height of wall (ft) (13.4)
h	=	depth of slab (in.) (A13.4.3.2)
L	=	post spacing of single span (ft) (A13.3.2)
L_c	=	critical length of wall failure (ft) (A13.3.1)
L_L	=	longitudinal length of distribution of friction force F_L , $L_L = L_t$ (ft) (A13.2)
L_t	=	longitudinal length of distribution of impact force F_t along the railing located a height of the H_e above the deck (ft) (A13.2)
L_v	=	longitudinal distribution of vertical force F_v on top of railing (ft) (A13.2)
ℓ	=	length of vehicle impact load on railing or barrier taken as L_b , L_v , or L_L , as appropriate (ft) (A13.3.1)
M_b	=	ultimate moment capacity of beam at top of wall (kip-ft) (A13.3.1)
M_c	=	ultimate flexural resistance of wall about horizontal axis (kip-ft/ft) (A13.3.1)
M_d	=	deck overhang moment (kip-ft/ft) (A13.4.3.1)
M_p	=	plastic or yield line resistance of rail (kip-ft) (A13.3.2)
M_{post}	=	plastic moment resistance of a single post (kip-ft) (A13.3.2)
M_w	=	ultimate flexural resistance of wall about vertical axis (kip-ft) (A13.3.1)
P_p	=	shear force on a single post which corresponds to M_{post} and is located \bar{Y} above the deck (kips) (A13.3.2)
R	=	total ultimate resistance, i.e., nominal resistance, of the railing (kips) (A13.3.2)
R_R	=	ultimate capacity of rail over one span (kips) (A13.3.3)
R'_R	=	ultimate transverse resistance of rail over two spans (kips) (A13.3.3)
R_w	=	total transverse resistance of the railing (kips); ultimate capacity of wall as specified in Article A13.3.1 (kips) (A13.3.1) (A13.3.3)
R'_w	=	capacity of wall, reduced to resist post load (kips) (A13.3.3)
\bar{R}	=	sum of horizontal components of rail strengths (kips) (A13.2)
T	=	tensile force per unit of deck length (kip/ft) (A13.4.2)
V_c	=	nominal shear resistance provided by tensile stresses in the concrete (kips) (A13.4.3.2)
V_n	=	nominal shear resistance of the section considered (kips) (A13.4.3.2)
V_r	=	factored shear resistance (kips) (A13.4.3.2)
V_u	=	factored shear force at section (kips) (A13.4.3.2)
W	=	weight of vehicle corresponding to the required test level, from Table 13.7.2-1 (kips) (13.7.2)
W_b	=	width of base plate or distribution block (ft); width of base plate (in.) (A13.4.3.1) (A13.4.3.2)
X	=	length of overhang from face of support to exterior girder or web (ft) (A13.4.3.1)
\bar{Y}	=	height of \bar{R} above bridge deck (in.) (A13.2)
β_c	=	ratio of the long side to the short side of the concentrated load or reaction area (A13.4.3.2)
ϕ	=	resistance factor = 1.0 (A13.4.3.2)

13.4—GENERAL

The Owner shall develop the warrants for the bridge site. A bridge railing should be chosen to satisfy the concerns of the warrants as completely as possible and practical.

Railings shall be provided along the edges of structures for protection of traffic and pedestrians. Other applications may be warranted on bridge-length culverts.

C13.4

Additional guidance applicable to bridge-length culverts may be found in the AASHTO *Roadside Design Guide*.

A pedestrian walkway may be separated from an adjacent roadway by a barrier curb, traffic railing, or combination railing, as indicated in Figure 13.4-1. On high-speed urban expressways where a pedestrian walkway is provided, the walkway area shall be separated from the adjacent roadway by a traffic railing or combination railing.

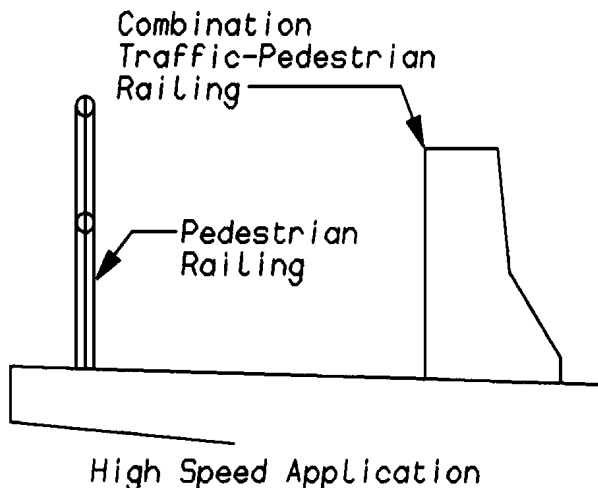
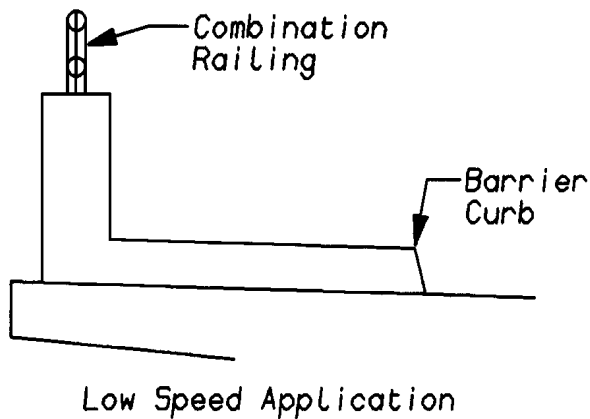

Figure 13.4-1—Pedestrian Walkway

New bridge railings and the attachment to the deck overhang shall satisfy crash testing requirements to confirm that they meet the structural and geometric requirements of a specified railing test level using the test criteria specified in Article 13.7.2.

The following guidelines indicate the application of various types of rails:

- Traffic railing is used when a bridge is for the exclusive use of highway traffic;
- A combination barrier in conjunction with a raised curb and sidewalk is used only on low-speed highways;
- On high-speed highways, the pedestrian or bicycle path should have both an outboard pedestrian or bicycle railing and an inboard combination railing; and
- Separate pedestrian bridges should be considered where the amount of pedestrian traffic or other risk factors so indicate.

For the purpose of this Article, low speed may be taken as speeds not exceeding 45 mph. High speed may be taken as speeds in excess of 45 mph.

The walkway faces of combination railings separating walkways from adjacent roadways serve as pedestrian or bicycle railings. When the height of such railings above the walkway surface is less than the minimum height required for pedestrian or bicycle railings, as appropriate, the Designer may consider providing additional components, such as metal rails, on top of the combination railing. The additional components need to be designed for the appropriate pedestrian or bicycle railing design forces.

Warning devices for pedestrians are beyond the scope of these Specifications, but they should be considered.

Procedures for testing railing are given in AASHTO's *Manual for Assessing Safety Hardware*.

13.5—MATERIALS

The requirements of Sections 5, 6, 7, and 8 shall apply to the materials employed in a railing system, unless otherwise modified herein.

13.6—LIMIT STATES AND RESISTANCE FACTORS**13.6.1—Strength Limit State**

The strength limit states shall apply using the applicable load combinations in Table 3.4.1-1 and the loads specified herein. The resistance factors for post and railing components shall be as specified in Articles 5.5.4, 6.5.4, 7.5.4, and 8.5.2.

Design loads for pedestrian railings shall be as specified in Article 13.8.2. Design loads for bicycle railings shall be as specified in Article 13.9.3. Pedestrian or bicycle loadings shall be applied to combination railings as specified in Article 13.10.3. Deck overhangs shall be designed for applicable strength load combinations specified in Table 3.4.1-1.

13.6.2—Extreme Event Limit State

The forces to be transmitted from the bridge railing to the bridge deck may be determined from an ultimate strength analysis of the railing system using the loads given in Appendix A. Those forces shall be considered to be the factored loads at the extreme event limit state.

13.7—TRAFFIC RAILING**13.7.1—Railing System****13.7.1.1—General**

The primary purpose of traffic railings shall be to contain and redirect vehicles using the structure. All new vehicle traffic barrier systems, traffic railings, and combination railings shall be shown to be structurally and geometrically crashworthy.

Consideration should be given to:

- Protection of the occupants of a vehicle in collision with the railing,
- Protection of other vehicles near the collision,
- Protection of persons and property on roadways and other areas underneath the structure,
- Possible future rail upgrading,
- Railing cost-effectiveness, and
- Appearance and freedom of view from passing vehicles.

C13.5

Factors to be considered in choosing the material for use in any railing system include ultimate strength, durability, ductility, maintenance, ease of replacement, and long-term behavior.

C13.7.1.1

Variations in traffic volume, speed, vehicle mix, roadway alignment, activities and conditions beneath a structure, and other factors combine to produce a vast variation in traffic railing performance requirements.

A combination railing, conforming to the dimensions given in Figures 13.8.2-1 and 13.9.3-1, and crash tested with a sidewalk may be considered acceptable for use with sidewalks having widths 3.5 ft or greater and curb heights up to the height used in the crash test installation.

A railing designed for multiple use shall be shown to be crashworthy with or without the sidewalk. Use of the combination vehicle-pedestrian rail shown in Figure 13.7.1.1-1 shall be restricted to roads designated for 45 mph or less and need be tested to Test Level 1 or 2.

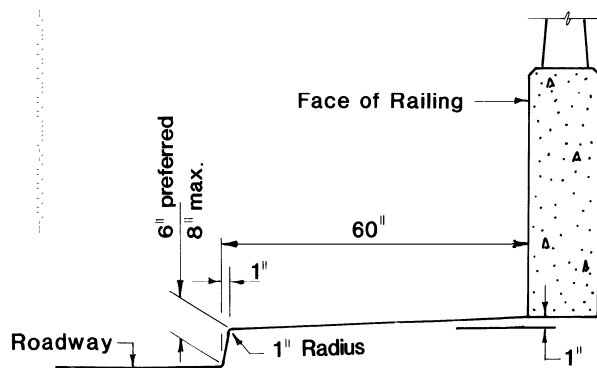

Figure 13.7.1.1-1—Typical Raised Sidewalk

13.7.1.2—Approach Railings

An approach guardrail system should be provided at the beginning of all bridge railings in high-speed rural areas.

A bridge approach railing system should include a transition from the guardrail system to the rigid bridge railing system that is capable of providing lateral resistance to an errant vehicle. The approach guardrail system shall have a crashworthy end terminal at its nosing.

13.7.1.3—End Treatment

In high-speed rural areas, the approach end of a parapet or railing shall have a crashworthy configuration or be shielded by a crashworthy traffic barrier.

Because of more recent tests on sidewalks, an 8.0-in. maximum height for sidewalk curbs has generally been accepted.

AASHTO's *A Policy on Geometric Design of Highways and Streets* recommends that a barrier curb be used only for speeds of 45 mph or less. For speeds of 50 mph or greater, pedestrians should be protected by a separation traffic barrier.

A railing intended for use only on a sidewalk need not be tested without the sidewalk.

C13.7.1.2

In urban areas or where city streets and/or sidewalks prevent installation of approach guardrail transitions or crashworthy terminals, consideration should be given to:

- Extending the bridge rail or guard rail in a manner that prevents encroachment of a vehicle onto any highway system below the bridge,
- Providing a barrier curb,
- Restricting speed,
- Adding signing of intersections, and
- Providing recovery areas.

A bridge end drainage facility should be an integral part of the barrier transition design.

C13.7.1.3

If the approach railing is connected to a side of road railing system, it can be continuous with the bridge approach system, and only a transition from a flexible to a rigid railing system is required.

13.7.2—Test Level Selection Criteria

One of the following test levels should be specified:

- TL-1—Test Level One—taken to be generally acceptable for work zones with low posted speeds and very low volume, low speed local streets;
- TL-2—Test Level Two—taken to be generally acceptable for work zones and most local and collector roads with favorable site conditions as well as where a small number of heavy vehicles is expected and posted speeds are reduced;
- TL-3—Test Level Three—taken to be generally acceptable for a wide range of high-speed arterial highways with very low mixtures of heavy vehicles and with favorable site conditions;
- TL-4—Test Level Four—taken to be generally acceptable for the majority of applications on high speed highways, freeways, expressways, and Interstate highways with a mixture of trucks and heavy vehicles;
- TL-5—Test Level Five—taken to be generally acceptable for the same applications as TL-4 and where large trucks make up a significant portion of the average daily traffic or when unfavorable site conditions justify a higher level of rail resistance; and
- TL-6—Test Level Six—taken to be generally acceptable for applications where tanker-type trucks or similar high center of gravity vehicles are anticipated, particularly along with unfavorable site conditions.

It shall be the responsibility of the user agency to determine which of the test levels is most appropriate for the bridge site.

The testing criteria for the chosen test level shall correspond to vehicle weights and speeds and angles of impact outlined in Table 13.7.2-1.

C13.7.2

The six test levels mentioned herein are intended to correspond with the six test levels contained in AASHTO's *Manual for Assessing Safety Hardware* and NCHRP Report 350, "Recommended Procedures for the Safety Performance Evaluation of Highway Features." AASHTO's *A Policy on Geometric Design of Highways and Streets* (2004) and its *Roadside Design Guide* (2002) are referred to as aides in the bridge railing selection process.

The individual tests are designed to evaluate one or more of the principal performance factors of the bridge railing, which include structural adequacy, occupant risk, and postimpact behavior of the test vehicle. In general, the lower test levels are applicable for evaluating and selecting bridge railings to be used on segments of lower service level roadways and certain types of work zones. The higher test levels are applicable for evaluating and selecting bridge railings to be used on higher service level roadways or at locations that demand a special, high-performance bridge railing. In this regard, TL-4 railings are expected to satisfy the majority of interstate design requirements.

TL-5 provides for a van-type tractor-trailer that will satisfy design requirements where TL-4 railings are deemed to be inadequate due to the high number of this type of vehicle anticipated, or due to unfavorable site conditions where rollover or penetration beyond the railing could result in severe consequences.

TL-6 provides for a tanker-type truck that will satisfy design requirements where this type vehicle with a higher center of gravity has shown a history of rollover or penetration, or unfavorable site conditions may indicate the need for this level of rail resistance.

Unfavorable site conditions include but are not limited to reduced radius of curvature, steep downgrades on curvature, variable cross slopes, and adverse weather conditions.

Agencies should develop objective guidelines for use of bridge railings. These guidelines should take into account factors such as traffic conditions, traffic volume and mix, cost and in-service performance, and life-cycle cost of existing railings.

These criteria, including other vehicle characteristics and tolerances, are described in detail in AASHTO's *Manual for Assessing Safety Hardware* and the NCHRP Report 350.

Table 13.7.2-1—Bridge Railing Test Levels and Crash Test Criteria

	Vehicle Characteristics	Small Automobiles		Pickup Truck	Single-Unit Van Truck	Van-Type Tractor-Trailer		Tractor-Tanker Trailer
NCHRP Report 350	W (kips)	1.55	1.8	4.5	18.0	50.0	80.0	80.0
	B (ft.)	5.5	5.5	6.5	7.5	8.0	8.0	8.0
	G (in.)	22	22	27	49	64	73	81
	Crash angle, θ	20°	20°	25°	15°	15°	15°	15°
	Test Level	Test Speeds (mph)						
	TL-1	30	30	30	N/A	N/A	N/A	N/A
	TL-2	45	45	45	N/A	N/A	N/A	N/A
	TL-3	60	60	60	N/A	N/A	N/A	N/A
	TL-4	60	60	60	50	N/A	N/A	N/A
	TL-5	60	60	60	N/A	N/A	50	N/A
TL-6	60	60	60	N/A	N/A	N/A	50	
AASHTO MASH	W (kips)	2.42	3.3	5.0	22.0	N/A	79.3	79.3
	B (ft.)	5.5	5.5	6.5	7.5	N/A	8.0	8.0
	G (in.)	N/A	N/A	28	63	N/A	73	81
	Crash angle, θ	25°	N/A	25°	15°	N/A	15°	15°
	Test Level	Test Speeds (mph)						
	TL-1	30	N/A	30	N/A	N/A	N/A	N/A
	TL-2	45	N/A	45	N/A	N/A	N/A	N/A
	TL-3	60	N/A	60	N/A	N/A	N/A	N/A
TL-4	60	N/A	60	55	N/A	N/A	N/A	
TL-5	60	N/A	60	N/A	N/A	50	N/A	
TL-6	60	N/A	60	N/A	N/A	N/A	50	

13.7.3—Railing Design

13.7.3.1—General

A traffic railing should normally provide a smooth continuous face of rail on the traffic side. Steel posts with rail elements should be set back from the face of rail. Structural continuity in the rail members and anchorages of ends should be considered.

A railing system and its connection to the deck shall be approved only after they have been shown through crash testing to be satisfactory for the desired test level.

13.7.3.1.1—Application of Previously Tested Systems

A crashworthy railing system may be used without further analysis and/or testing, provided that the proposed installation does not have features that are absent in the tested configuration and that might detract from the performance of the tested railing system.

C13.7.3.1

Protrusions or depressions at rail openings may be acceptable, provided that their thickness, depth, or geometry does not prevent the railing from meeting the crash test evaluation criteria.

Test specimens should include a representative length of the overhang to account for the effect of deck flexibility on the distance over which the railing engages the deck.

C13.7.3.1.1

When a minor detail is changed on or an improvement is made to a railing system that has already been tested and approved, engineering judgment and analysis should be used when determining the need for additional crash testing.

13.7.3.1.2—New Systems

New railing systems may be used, provided that acceptable performance is demonstrated through full-scale crash tests.

The crash test specimen for a railing system may be designed to resist the applied loads in accordance with Appendix A13.

Provision shall be made to transfer loads from the railing system to the deck. Railing loads may be taken from Appendix A13.

Unless a lesser thickness can be proven satisfactory during the crash testing procedure, the minimum edge thickness for concrete deck overhangs shall be taken as:

- For concrete deck overhangs supporting a deck-mounted post system: 8.0 in.
- For a side-mounted post system: 12.0 in.
- For concrete deck overhangs supporting concrete parapets or barriers: 8.0 in.

13.7.3.2—Height of Traffic Parapet or Railing

Traffic railings shall be at least 27.0 in. for TL-3, 32.0 in. for TL-4, 42.0 in. for TL-5, and 90.0 in. in height for TL-6.

The bottom 3.0-in. lip of the safety shape shall not be increased for future overlay considerations.

The minimum height for a concrete parapet with a vertical face shall be 27.0 in. The height of other combined concrete and metal rails shall not be less than 27.0 in. and shall be determined to be satisfactory through crash testing for the desired test level.

The minimum height of the pedestrian or bicycle railing should be measured above the surface of the sidewalk or bikeway.

The minimum geometric requirements for combination railings beyond those required to meet crash test requirements shall be taken as specified in Articles 13.8, 13.9, and 13.10.

13.8—PEDESTRIAN RAILING**13.8.1—Geometry**

The minimum height of a pedestrian railing shall be 42.0 in. measured from the top of the walkway.

A pedestrian rail may be composed of horizontal and/or vertical elements. The clear opening between elements shall be such that a 6.0 in. diameter sphere shall not pass through.

When both horizontal and vertical elements are used, the 6.0 in. clear opening shall apply to the lower 27.0 in. of the railing, and the spacing in the upper portion shall be such that a 8.0-in. diameter sphere shall not pass through.

C13.7.3.1.2

Preliminary design for bridge decks should comply with Article A13.1.2. A determination of the adequacy of deck reinforcement for the distribution of post anchorage loads to the deck should be made during the rail testing program. If the rail testing program satisfactorily models the bridge deck, damage to the deck edge can be assessed at this time.

In adequately designed bridge deck overhangs, the major crash-related damage presently occurs in short sections of slab areas where the barrier is hit.

C13.7.3.2

These heights have been determined as satisfactory through crash tests performed in accordance with NCHRP Report 350 and experience.

For future deck overlays, an encroachment of 2.0 in., leaving a 1.0-in. lip, has been satisfactorily tested for safety shapes.

C13.8.1

A safety toe rail or curb should be provided. Rails should project beyond the face of posts and/or pickets as shown in Figure A13.1.1-2.

The rail spacing requirements given above should not apply to chain link or metal fabric fence support rails and posts. Mesh size in chain link or metal fabric fence should have openings no larger than 2.0 in.

13.8.2—Design Live Loads

The design live load for pedestrian railings shall be taken as $w = 0.050$ klf, both transversely and vertically, acting simultaneously. In addition, each longitudinal element will be designed for a concentrated load of 0.20 kips, which shall act simultaneously with the above loads at any point and in any direction at the top of the longitudinal element.

The posts of pedestrian railings shall be designed for a concentrated design live load applied transversely at the center of gravity of the upper longitudinal element or, for railings with a total height greater than 5.0 ft, at a point 5.0 ft above the top surface of the sidewalk. The value of the concentrated design live load for posts, P_{LL} , in kips, shall be taken as:

$$P_{LL} = 0.20 + 0.050L \tag{13.8.2-1}$$

where:

L = post spacing (ft)

The design load for chain link or metal fabric fence shall be 0.015 ksf acting normal to the entire surface.

The application of loads shall be as indicated in Figure 13.8.2-1, in which the shapes of rail members are illustrative only. Any material or combination of materials specified in Article 13.5 may be used.

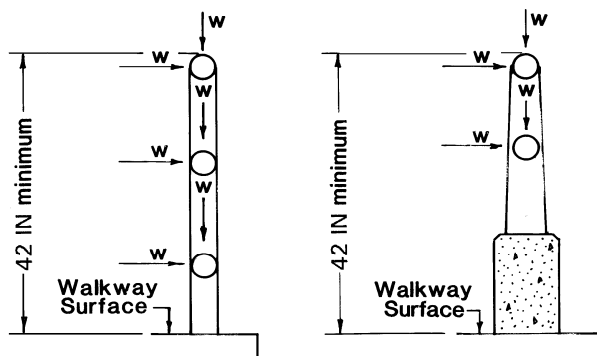

Figure 13.8.2-1—Pedestrian Railing Loads—To be used on the outer edge of a sidewalk when highway traffic is separated from pedestrian traffic by a traffic railing. Railing shape illustrative only.

The size of openings should be capable of retaining an average size beverage container.

C13.8.2

These live loads apply to the railing. The pedestrian live load, specified in Article 3.6.1.6, applies to the sidewalk.

13.9—BICYCLE RAILINGS

13.9.1—General

Bicycle railings shall be used on bridges specifically designed to carry bicycle traffic and on bridges where specific protection of bicyclists is deemed necessary.

13.9.2—Geometry

The height of a bicycle railing shall not be less than 42.0 in., measured from the top of the riding surface.

The height of the upper and lower zones of a bicycle railing shall be at least 27.0 in. The upper and lower zones shall have rail spacing satisfying the respective provisions of Article 13.8.1.

If deemed necessary, rubrails attached to the rail or fence to prevent snagging should be deep enough to protect a wide range of bicycle handlebar heights.

If screening, fencing, or a solid face is utilized, the number of rails may be reduced.

13.9.3—Design Live Loads

If the rail height exceeds 54.0 in. above the riding surface, design loads shall be determined by the Designer. The design loads for the lower 54.0 in. of the bicycle railing shall not be less than those specified in Article 13.8.2, except that for railings with total height greater than 54.0 in., the design live load for posts shall be applied at a point 54.0 in. above the riding surface.

The application of loads shall be as indicated in Figure 13.9.3-1. Any material or combination of materials specified in Article 13.5 may be used.

C13.9.2

Railings, fences or barriers on either side of a shared use path on a structure, or along bicycle lane, shared use path or signed shared roadway located on a highway bridge should be a minimum of 42.0 in. high. The 42.0-in. minimum height is in accordance with the *AASHTO Guide for the Development of Bicycle Facilities*, Third Edition (1999).

On such a bridge or bridge approach where high-speed high-angle impact with a railing, fence or barrier are more likely to occur (such as short radius curves with restricted sight distance or at the end of a long descending grade) or in locations with site-specific safety concerns, a railing, fence or barrier height above the minimum should be considered.

The need for rubrails attached to a rail or fence is controversial among many bicyclists.

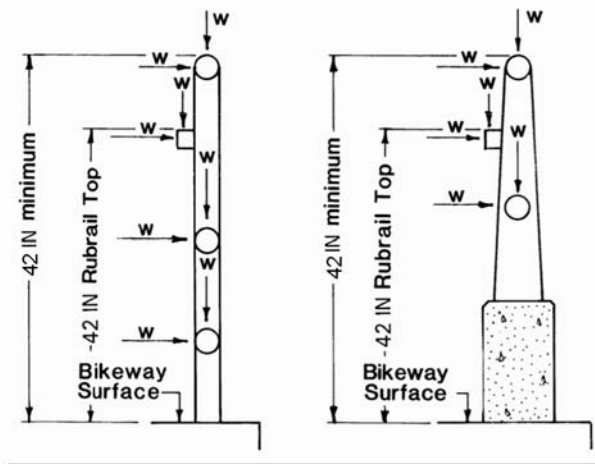

Figure 13.9.3-1—Bicycle Railing Loads—To be used on the outer edge of a bikeway when highway traffic is separated from bicycle traffic by a traffic railing. Railing shape illustrative only.

13.10—COMBINATION RAILINGS

13.10.1—General

The combination railing shall conform to the requirements of either the pedestrian or bicycle railings, as specified in Articles 13.8 and 13.9, whichever is applicable. The traffic railing portion of the combination railing shall conform to Article 13.7.

13.10.2—Geometry

The geometric provisions of Articles 13.7, 13.8, and 13.9 shall apply to their respective portions of a combination railing.

13.10.3—Design Live Loads

Design loads, specified in Articles 13.8 and 13.9, shall not be applied simultaneously with the vehicular impact loads.

13.11—CURBS AND SIDEWALKS

13.11.1—General

Horizontal measurements of roadway width shall be taken from the bottom of the face of the curb. A sidewalk curb located on the highway traffic side of a bridge railing shall be considered an integral part of the railing and shall be subject to the crash test requirements specified in Article 13.7.

13.11.2—Sidewalks

When curb and gutter sections with sidewalks are used on roadway approaches, the curb height for raised sidewalks on the bridge should be no more than 8.0 in. If a barrier curb is required, the curb height should not be less than 6.0 in. If the height of the curb on the bridge differs from that off the bridge, it should be uniformly transitioned over a distance greater than or equal to 20 times the change in height.

13.11.3—End Treatment of Separation Railing

The end treatment of any traffic railing or barrier shall meet the requirements specified in Articles 13.7.1.2 and 13.7.1.3.

13.12—REFERENCES

AASHTO. 2009. *Manual for Assessing Safety Hardware*, MASH-1. American Association of State Highway and Transportation Officials, Washington, DC.

AASHTO. 2011. *A Policy on Geometric Design of Highways and Streets*, Sixth Edition, GDHS-6. American Association of State Highway and Transportation Officials, Washington, DC.

AASHTO. 2011. *Roadside Design Guide*, Fourth Edition, RSDG-4. American Association of State Highway and Transportation Officials, Washington, DC.

Alberson, D. C., R. A. Zimmer, and W. L. Menges. 1997. *NCHRP Report 350 Compliance Test 5-12 of the 1.07-m Vertical Wall Bridge Railing*, FHWA/RD-96/199. Federal Highway Administration, U.S. Department of Transportation, Washington, DC.

Buth, C. E., W. L. Campise, L. I. Griffin, M. L. Love, and D. L. Sicking. 1986. *Performance Limits of Longitudinal Barriers*, FHWA/RD-86/153, Test 4798-13. Federal Highway Administration, U.S. Department of Transportation, Washington, DC.

Michie, J. D. 1981. *NCHRP Report 230: Recommended Procedures for the Safety Performance Evaluation of Highway Appurtenances*. Transportation Research Board, National Research Council, Washington, DC.

Ross, H. E., D. L. Sicking, R. A. Zimmer, and J. D. Michie. 1993. *NCHRP Report 350: Recommended Procedures for the Safety Performance Evaluation of Highway Features*. Transportation Research Board, National Research Council, Washington, DC.

C13.11.2

Raised sidewalks on bridges are not usually provided where the approach roadway is not curbed for pedestrians or the structure is not planned for pedestrian occupancy.

For recommendations on sidewalk width, see Figure 13.7.1.1-1 and AASHTO's *A Policy on Geometric Design of Highways and Streets*.

During stage construction, the same transition considerations will be given to the provision of ramps from the bridge sidewalk to the approach surface.

APPENDIX A13—RAILINGS

A13.1—GEOMETRY AND ANCHORAGES

A13.1.1—Separation of Rail Elements

For traffic railings, the criteria for maximum clear opening below the bottom rail, c_b , the setback distance, S , and maximum opening between rails, c , shall be based on the following criteria:

- The rail contact widths for typical railings may be taken as illustrated in Figure A13.1.1-1;
- The total width of the rail(s) in contact with the vehicle, ΣA , shall not be less than 25 percent of the height of the railing;
- For post railings, the vertical clear opening, c , and the post setback, S , shall be within or below the shaded area shown in Figure A13.1.1-2; and
- For post railings, the combination of $(\Sigma A/H)$ and the post setback, S shall be within or above the shaded area shown in Figure A13.1.1-3.

CA13.1.1

The post setback shown from face of rail for various post shapes is based upon a limited amount of crash test data. The potential for wheel snagging involved with a given design should be evaluated as part of the crash test program.

The post setback, S , shown for various shape posts in Figure A13.1.1-2, recognizes the tendency for various shape posts to snag wheels. The implication of the various definitions of setback, S , is that all other factors being equal, the space between a rail and the face of a rectangular post will be greater than the distance between a rail and the face of a circular post.

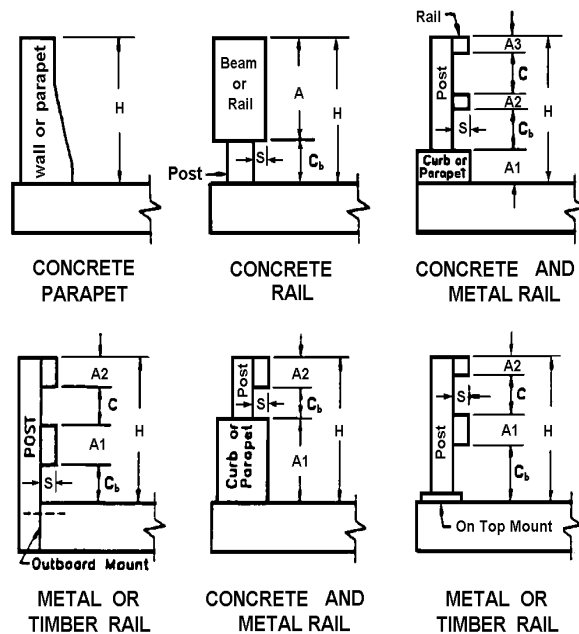

Figure A13.1.1-1—Typical Traffic Railings

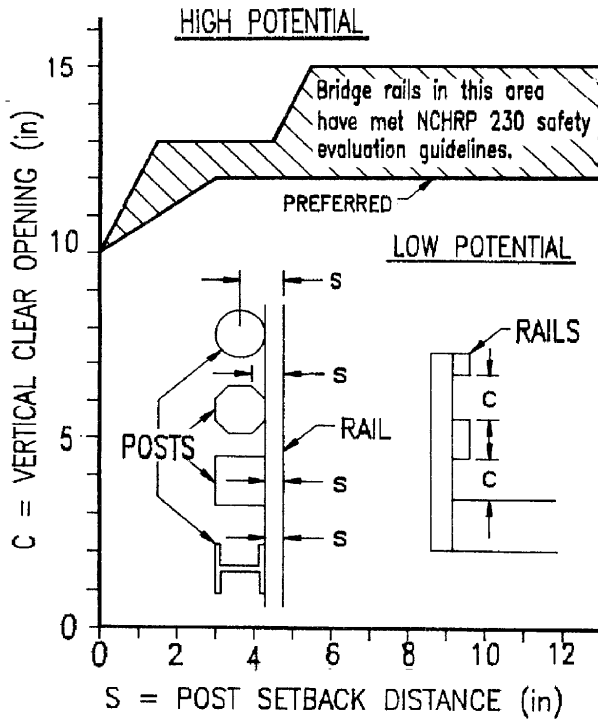

Figure A13.1.1-2—Potential for Wheel, Bumper, or Hood Impact with Post

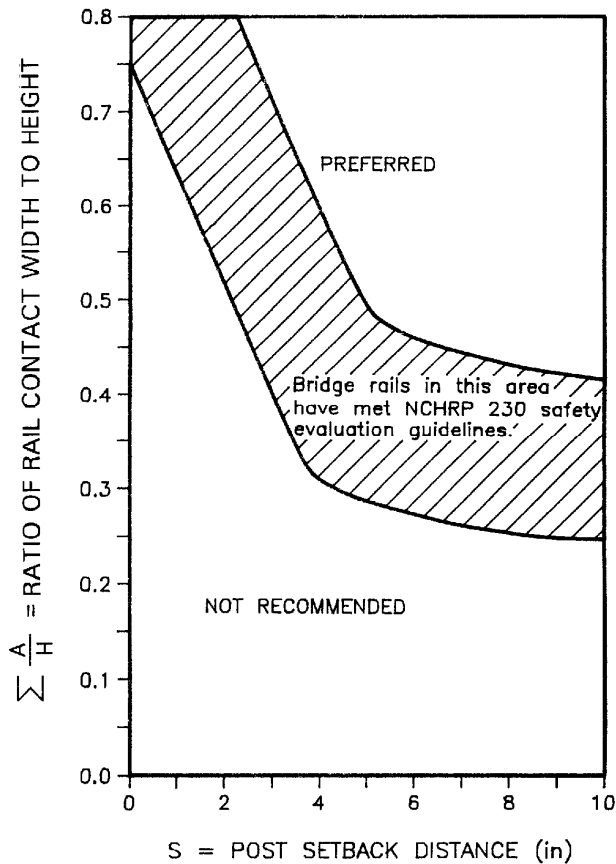

Figure A13.1.1-3—Post Setback Criteria

The maximum clear vertical opening between succeeding rails or posts shall be as specified in Articles 13.8, 13.9, and 13.10.

A13.1.2—Anchorages

The yield strength of anchor bolts for steel railing shall be fully developed by bond, hooks, attachment to embedded plates, or any combination thereof.

Reinforcing steel for concrete barriers shall have embedment length sufficient to develop the yield strength.

A13.2—TRAFFIC RAILING DESIGN FORCES

Unless modified herein, the extreme event limit state and the corresponding load combinations in Table 3.4.1-1 shall apply.

Railing design forces and geometric criteria to be used in developing test specimens for a crash test program should be taken as specified in Table A13.2-1 and illustrated in Figure A13.2-1. The transverse and longitudinal loads given in Table A13.2-1 need not be applied in conjunction with vertical loads.

The effective height of the vehicle rollover force is taken as:

$$H_e = G - \frac{12WB}{2F_t} \quad (\text{A13.2-1})$$

where:

G = height of vehicle center of gravity above bridge deck, as specified in Table 13.7.2-1 (in.)

W = weight of vehicle corresponding to the required test level, as specified in Table 13.7.2-1 (kips)

B = out-to-out wheel spacing on an axle, as specified in Table 13.7.2-1 (ft)

F_t = transverse force corresponding to the required test level, as specified in Table A13.2-1 (kips)

Railings shall be proportioned such that:

$$\bar{R} \geq F_t \quad (\text{A13.2-2})$$

$$\bar{Y} \geq \frac{H_e}{12} \quad (\text{A13.2-3})$$

in which:

$$\bar{R} = \sum R_i \quad (\text{A13.2-4})$$

CA13.1.2

Noncorrosive bonding agents for anchor dowels may be cement grout, epoxy, or a magnesium phosphate compound. Sulfur or expansive-type grouts should not be used.

Some bonding agents on the market have corrosive characteristics; these should be avoided.

Development length for reinforcing bars is specified in Section 5.

CA13.2

Nomenclature for Eqs. A13.2-1 and A13.2-2 is illustrated in Figure CA13.2-1.

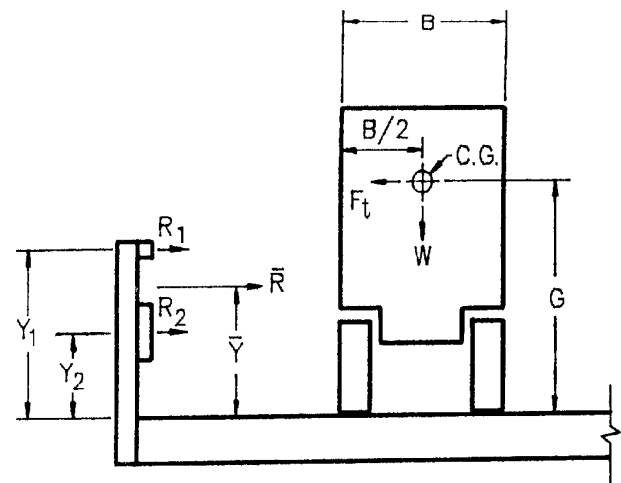

Figure CA13.2-1—Traffic Railing

If the total resistance, \bar{R} , of a post-and-beam railing system with multiple rail elements is significantly greater than the applied load, F_t , then the resistance, R_i , for the lower rail element(s) used in calculations may be reduced.

The reduced value of \bar{R} will result in an increase in the computed value of \bar{Y} . The reduced notional total rail resistance and its effective height must satisfy Eqs. A13.2-2 and A13.2-3.

$$\bar{Y} = \frac{\Sigma(R_i Y_i)}{\bar{R}} \quad (\text{A13.2-5})$$

where:

R_i = resistance of the rail (kips)

Y_i = distance from bridge deck to the i th rail (ft)

All forces shall be applied to the longitudinal rail elements. The distribution of longitudinal loads to posts shall be consistent with the continuity of rail elements. Distribution of transverse loads shall be consistent with the assumed failure mechanism of the railing system.

Eq. A13.2-1 has been found to give reasonable predictions of effective railing height requirements to prevent rollover.

If the design load located at H_e falls between rail elements, it should be distributed proportionally to rail elements above and below such that $Y \geq H_e$.

As an example of the significance of the data in Table A13.2-1, the length of 4.0 ft for L_t and L_L is the length of significant contact between the vehicle and railing that has been observed in films of crash tests. The length of 3.5 ft for TL-4 is the rear-axle tire diameter of the truck. The length of 8.0 ft for TL-5 and TL-6 is the length of the tractor rear tandem axles: two 3.5-ft diameter tires, plus 1.0 ft between them.

F_v , the weight of the vehicle lying on top of the bridge rail, is distributed over the length of the vehicle in contact with the rail, L_v .

For concrete railings, Eq. A13.2-1 results in a theoretically-required height, H , of 34.0 in. for Test Level TL-4. However, a height of 32.0 in., shown in Table A13.2-1, was considered to be acceptable because many railings of that height have been built and appear to be performing acceptably.

The minimum height, H , listed for TL-1, TL-2, and TL-3 is based on the minimum railings height used in the past. The minimum effective height, H_e , for TL-1 is an estimate based on the limited information available for this test level.

The minimum height, H , of 42.0 in., shown in Table A13.2-1, for TL-5 is based on the height used for successfully crash-tested concrete barrier engaging only the tires of the truck. For post and beam metal bridge railings, it may be prudent to increase the height by 12.0 in. so as to engage the bed of the truck.

The minimum height, H , shown in Table A13.2-1, for TL-6 is the height required to engage the side of the tank as determined by crash test.

Table A13.2-1—Design Forces for Traffic Railings

Design Forces and Designations	Railing Test Levels					
	TL-1	TL-2	TL-3	TL-4	TL-5	TL-6
F_t Transverse (kips)	13.5	27.0	54.0	54.0	124.0	175.0
F_L Longitudinal (kips)	4.5	9.0	18.0	18.0	41.0	58.0
F_v Vertical (kips) Down	4.5	4.5	4.5	18.0	80.0	80.0
L_t and L_L (ft)	4.0	4.0	4.0	3.5	8.0	8.0
L_v (ft)	18.0	18.0	18.0	18.0	40.0	40.0
H_e (min) (in.)	18.0	20.0	24.0	32.0	42.0	56.0
Minimum H Height of Rail (in.)	27.0	27.0	27.0	32.0	42.0	90.0

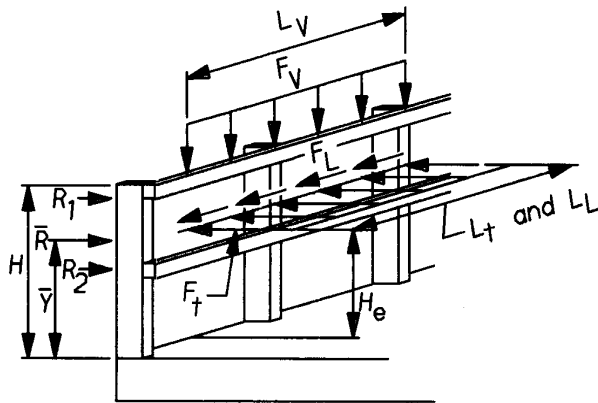

Figure A13.2-1—Metal Bridge Railing Design Forces, Vertical Location, and Horizontal Distribution Length

A13.3—DESIGN PROCEDURE FOR RAILING TEST SPECIMENS

A13.3.1—Concrete Railings

Yield line analysis and strength design for reinforced concrete and prestressed concrete barriers or parapets may be used.

The nominal railing resistance to transverse load, R_w , may be determined using a yield line approach as:

- For impacts within a wall segment:

$$R_w = \left(\frac{2}{2L_c - L_t} \right) \left(8M_b + 8M_w + \frac{M_c L_c^2}{H} \right) \quad (\text{A13.3.1-1})$$

The critical wall length over which the yield line mechanism occurs, L_c , shall be taken as:

$$L_c = \frac{L_t}{2} + \sqrt{\left(\frac{L_t}{2} \right)^2 + \frac{8H(M_b + M_w)}{M_c}} \quad (\text{A13.3.1-2})$$

- For impacts at end of wall or at joint:

$$R_w = \left(\frac{2}{2L_c - L_t} \right) \left(M_b + M_w + \frac{M_c L_c^2}{H} \right) \quad (\text{A13.3.1-3})$$

$$L_c = \frac{L_t}{2} + \sqrt{\left(\frac{L_t}{2} \right)^2 + H \left(\frac{M_b + M_w}{M_c} \right)} \quad (\text{A13.3.1-4})$$

where:

F_t = transverse force specified in Table A13.2-1 assumed to be acting at top of a concrete wall (kips)

Figure A13.2-1 shows the design forces from Table A13.2-1 applied to a beam and post railing. This is for illustrative purposes only. The forces and distribution lengths shown apply to any type of railing.

CA13.3.1

The yield line analysis shown in Figures CA13.3.1-1 and CA13.3.1-2 includes only the ultimate flexural capacity of the concrete component. Stirrups or ties should be provided to resist the shear and/or diagonal tension forces.

The ultimate flexural resistance, M_s , of the bridge deck or slab should be determined in recognition that the deck is also resisting a tensile force, caused by the component of the impact forces, F_t .

In this analysis it is assumed that the yield line failure pattern occurs within the parapet only and does not extend into the deck. This means that the deck must have sufficient resistance to force the yield line failure pattern to remain within the parapet. If the failure pattern extends into the deck, the equations for resistance of the parapet are not valid.

The analysis is also based on the assumption that sufficient longitudinal length of parapet exists to result in the yield line failure pattern shown. For short lengths of parapet, a single yield line may form along the juncture of the parapet and deck. Such a failure pattern is permissible, and the resistance of the parapet should be computed using an appropriate analysis.

This analysis is based on the assumption that the negative and positive wall resisting moments are equal and that the negative and positive beam resisting moments are equal.

The measurement of system resistance of a concrete railing is R_w , which is compared to the loads in Table A13.2-1 to determine structural adequacy. The flexure resistances, M_b , M_w , and M_c , are related to the system resistance R_w through the yield line analysis embodied in Eqs. A13.3.1-1 and A13.3.1-2. In the terminology of these Specifications, R_w is the “nominal resistance” because it is compared to the “nominal load” given in Table A13.2-1.

Where the width of the concrete railing varies along the height, M_c used in Eqs. A13.3.1-1 through A13.3.1-4 for wall resistance should be taken as the average of its value along the height of the railing.

- H = height of wall (ft)
- L_c = critical length of yield line failure pattern (ft)
- L_t = longitudinal length of distribution of impact force F_t (ft)
- R_w = total transverse resistance of the railing (kips)
- M_b = additional flexural resistance of beam in addition to M_w , if any, at top of wall (kip-ft)
- M_c = flexural resistance of cantilevered walls about an axis parallel to the longitudinal axis of the bridge (kip-ft/ft)
- M_w = flexural resistance of the wall about its vertical axis (kip-ft)

For use in the above equations, M_c and M_w should not vary significantly over the height of the wall. For other cases, a rigorous yield line analysis should be used.

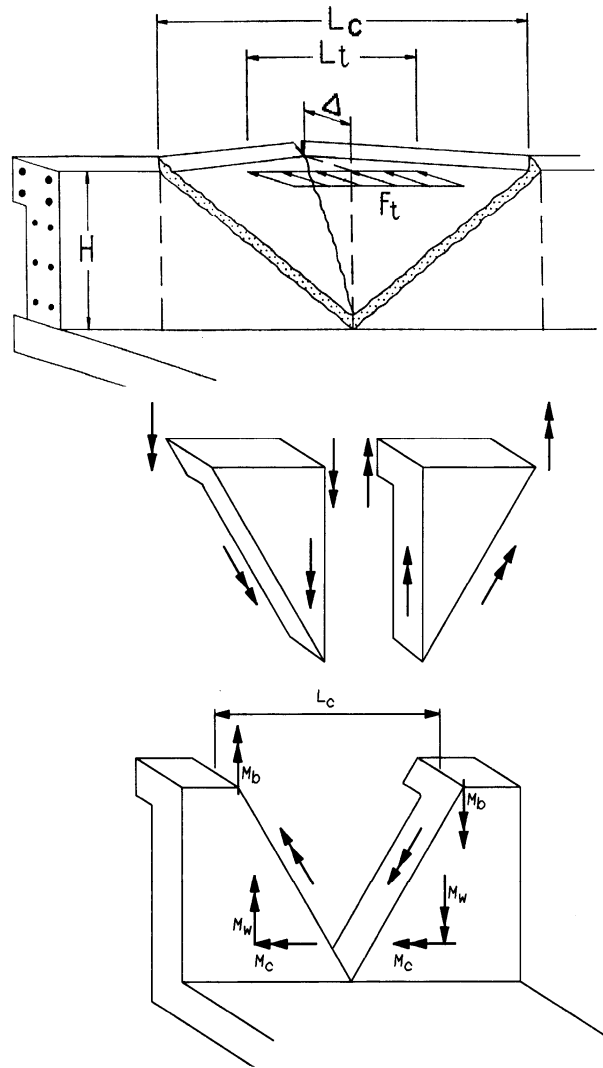

Figure CA13.3.1-1—Yield Line Analysis of Concrete Parapet Walls for Impact within Wall Segment

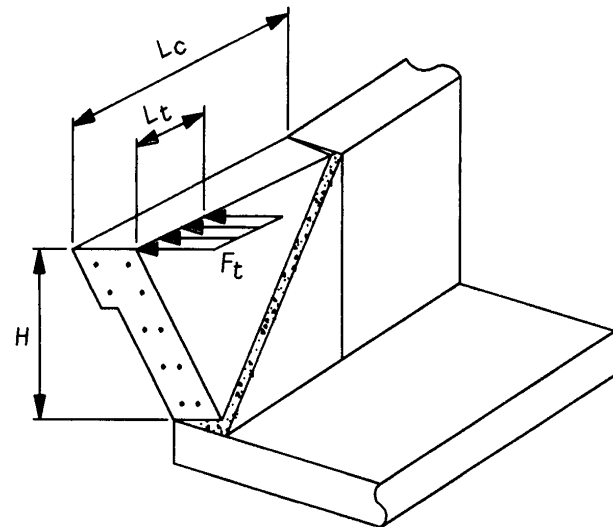

Figure CA13.3.1-2—Yield Line Analysis of Concrete Parapet Walls for Impact near End of Wall Segment

A13.3.2—Post-and-Beam Railings

Inelastic analysis shall be used for design of post-and-beam railings under failure conditions. The critical rail nominal resistance, R , when the failure does not involve the end post of a segment, shall be taken as the least value determined from Eqs. A13.3.2-1 and A13.3.2-2 for various numbers of railing spans, N .

CA13.3.2

A basis for applying inelastic analysis is shown in Figure CA13.3.2-1.

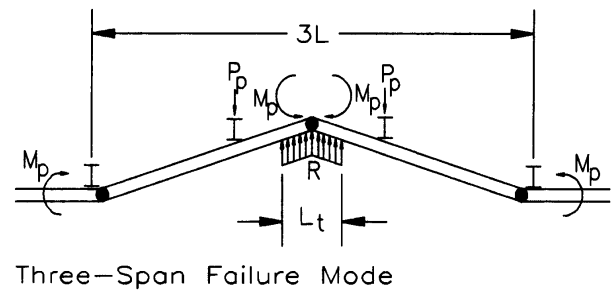
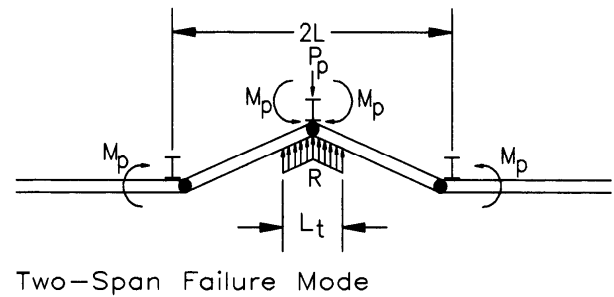
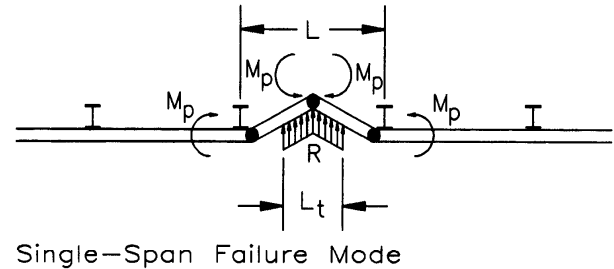

Figure CA13.3.2-1—Possible Failure Modes for Post-and-Beam Railings

- For failure modes involving an odd number of railing spans, N :

$$R = \frac{16M_p + (N-1)(N+1)P_p L}{2NL - L_t} \quad (\text{A13.3.2-1})$$

- For failure modes involving an even number of railing spans, N :

$$R = \frac{16M_p + N^2 P_p L}{2NL - L_t} \quad (\text{A13.3.2-2})$$

This design procedure is applicable to concrete and metal post and beam railings.

The post on each end of the plastic mechanism must be able to resist the rail or beam shear.

where:

- L = post spacing or single-span (ft)
- M_p = inelastic or yield line resistance of all of the rails contributing to a plastic hinge (kip-ft)
- M_{post} = plastic moment resistance of a single post (kip-ft)
- P_p = shear force on a single post which corresponds to M_{post} and is located \bar{Y} above the deck (kips)
- R = total ultimate resistance, i.e., nominal resistance, of the railing (kips)
- L_t, L_L = transverse length of distributed vehicle impact loads, F_t and F_L (ft)

For multiple rail systems, each of the rails may contribute to the yield mechanism shown schematically in Figure CA13.3.2-1, depending on the rotation corresponding to its vertical position.

For impact at the end of rail segments that causes the end post to fail, the critical rail nominal resistance, R , shall be calculated using Eq. A13.3.2-3.

- For any number of railing spans, N .

$$R = \frac{2M_p + 2P_p L \left(\sum_{i=1}^N i \right)}{2NL - L_t} \quad (\text{A13.3.2-3})$$

A13.3.3—Concrete Parapet and Metal Rail

CA13.3.3

The resistance of each component of a combination bridge rail shall be determined as specified in Articles A13.3.1 and A13.3.2. The flexural strength of the rail shall be determined over one span, R_R , and over two spans, R'_R . The resistance of the post on top of the wall, P_p , including the resistance of the anchor bolts or post shall be determined.

The resistance of the combination parapet and rail shall be taken as the lesser of the resistances determined for the two failure modes shown in Figures A13.3.3-1 and A13.3.3-2.

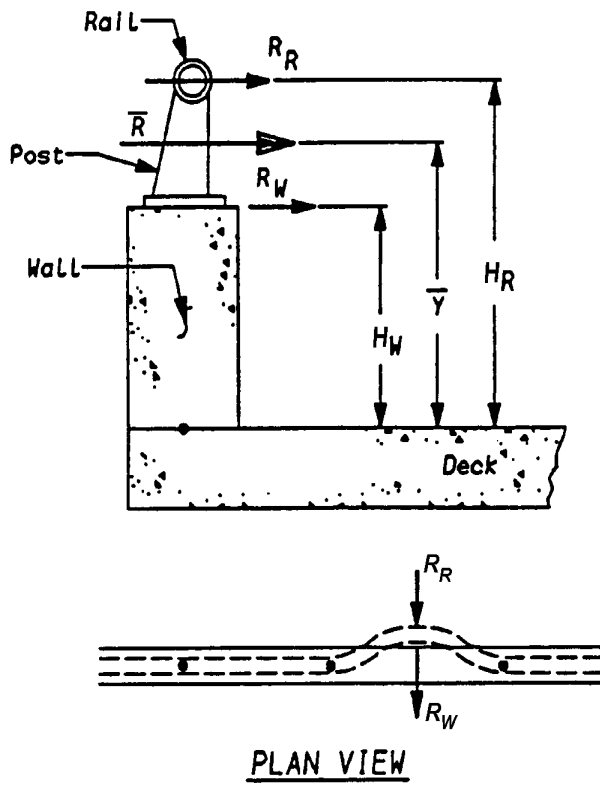

Figure A13.3.3-1—Concrete Wall and Metal Rail Evaluation—Impact at Midspan of Rail

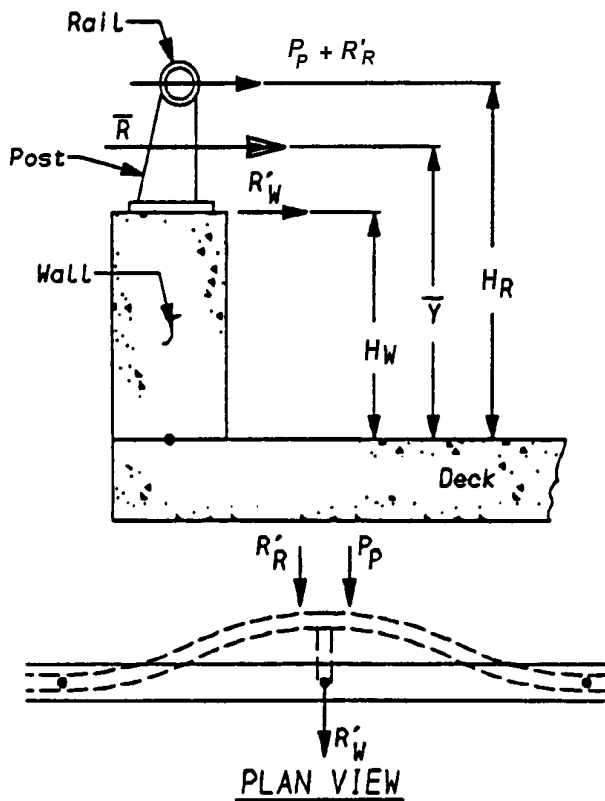

Figure A13.3.3-2—Concrete Wall and Metal Rail Evaluation—Impact at Post

Where the vehicle impact is at midspan of the metal rail, as illustrated in Figure A13.3.3-1, the flexural resistance of the rail, R_R , and the maximum strength of the concrete wall, R_w , shall be added together to determine the combined resultant strength, \bar{R} , and the effective height, \bar{Y} , taken as:

$$\bar{R} = R_R + R_w \quad (\text{A13.3.3-1})$$

$$\bar{Y} = \frac{R_R H_R + R_w H_w}{\bar{R}} \quad (\text{A13.3.3-2})$$

The commentary to Article CA13.2 applies.

where:

R_R = ultimate capacity of rail over one span (kips)

R_w = ultimate capacity of wall as specified in Article A13.3.1 (kips)

H_w = height of wall (ft)

H_R = height of rail (ft)

Where the vehicle impact is at a post, as illustrated in Figure A13.3.3-2, the maximum resultant strength, \bar{R} , shall be taken as the sum of the post capacity, P_p , the rail strength, R'_R , and a reduced wall strength, R'_w , located at a height \bar{Y} .

$$\bar{R} = P_p + R'_R + R'_w \quad (\text{A13.3.3-3})$$

$$\bar{Y} = \frac{P_p H_R + R'_R H_R + R'_w H_w}{\bar{R}} \quad (\text{A13.3.3-4})$$

in which:

$$R'_w = \frac{R_w H_w - P_p H_R}{H_w} \quad (\text{A13.3.3-5})$$

where:

P_p = ultimate transverse resistance of post (kips)

R'_R = ultimate transverse resistance of rail over two spans (kips)

R'_w = capacity of wall, reduced to resist post load (kips)

R_w = ultimate transverse resistance of wall as specified in Article A13.3.1 (kips)

A13.3.4—Wood Barriers

Wood barriers shall be designed by elastic linear analysis with member sections proportioned on the basis of their resistances, specified in Section 8, using the strength limit states and the applicable load combinations specified in Table 3.4.1-1.

It should also be recognized that a maximum effective height, \bar{Y} , equal to the centroid rail height, H_R , could be obtained, but at a reduced resultant strength, \bar{R} , equal to the post capacity, P_p , and rail capacity, R'_R , only.

The analysis herein does not consider impacts near open joints in the concrete wall or parapet. The metal rail will help distribute load across such joints. Improved rail resistance will be obtained if the use of expansion and contraction joints is minimized.

For impact near the end of railing segments, the nominal resistance may be calculated as the sum of the wall resistance, calculated using Eq. A13.3.1-3, and the metal rail resistance over one span, calculated using Eq. A13.3.2-3.

CA13.3.4

A limit or failure mechanism is not recommended for wood railings.

A13.4—DECK OVERHANG DESIGN**A13.4.1—Design Cases**

Bridge deck overhangs shall be designed for the following design cases considered separately:

Design Case 1: the transverse and longitudinal forces specified in Article A13.2 Extreme Event Load Combination II limit state

Design Case 2: the vertical forces specified in Article A13.2—Extreme Event Load Combination II limit state

Design Case 3: the loads, specified in Article 3.6.1, that occupy the overhang—Load Combination Strength I limit state

For Design Case 1 and 2, the load factor for dead load, γ_p , shall be taken as 1.0.

The total factored force effect shall be taken as:

$$Q = \sum \eta_i \gamma_i Q_i \quad (\text{A13.4.1-1})$$

where:

η_i = load modifier specified in Article 1.3.2

γ_i = load factors specified in Tables 3.4.1-1 and 3.4.1-2, unless specified elsewhere

Q_i = force effects from loads specified herein

A13.4.2—Decks Supporting Concrete Parapet Railings

For Design Case 1, the deck overhang may be designed to provide a flexural resistance, M_s in kip-ft/ft which, acting coincident with the tensile force T in kip/ft, specified herein, exceeds M_c of the parapet at its base. The axial tensile force, T , may be taken as:

$$T = \frac{R_w}{L_c + 2H} \quad (\text{A13.4.2-1})$$

where:

R_w = parapet resistance specified in Article A13.3.1 (kips)

L_c = critical length of yield line failure pattern (ft)

H = height of wall (ft)

T = tensile force per unit of deck length (kip/ft)

CA13.4.2

If the deck overhang capacity is less than that specified, the yield line failure mechanism for the parapet may not develop as shown in Figure CA13.3.1-1, and Eqs. A13.3.1-1 and A13.3.1-2 will not be correct.

The crash testing program is oriented toward survival, not necessarily the identification of the ultimate strength of the railing system. This could produce a railing system that is significantly oversized, leading to the possibility that the deck overhang is also oversized.

Design of the deck overhang for the vertical forces specified in Design Case 2 shall be based on the overhanging portion of the deck.

A13.4.3—Decks Supporting Post-and-Beam Railings

A13.4.3.1—Overhang Design

For Design Case 1, the moment per ft, M_d , and thrust per ft of deck, T , may be taken as:

$$M_d = \frac{M_{post}}{W_b + d_b} \quad (\text{A13.4.3.1-1})$$

$$T = \frac{P_p}{W_b + d_b} \quad (\text{A13.4.3.1-2})$$

For Design Case 2, the punching shear force and overhang moment may be taken as:

$$P_v = \frac{F_v L}{L_v} \quad (\text{A13.4.3.1-3})$$

$$M_d = \frac{P_v X}{b} \quad (\text{A13.4.3.1-4})$$

in which:

$$b = 2X + W_b \leq L \quad (\text{A13.4.3.1-5})$$

where:

M_{post} = plastic moment resistance of a single post (kip-ft)

P_p = shear force on a single post which corresponds to M_{post} and is located Y above the deck (kips)

X = distance from the outside edge of the post base plate to the section under investigation, as specified in Figure A13.4.3.1-1 (ft)

W_b = width of base plate (in.)

T = tensile force in deck (kip/ft)

d_b = distance from the outer edge of the base plate to the innermost row of bolts, as shown in Figure A13.4.3.1-1 (in.)

L = post spacing (ft)

L_v = longitudinal distribution of vertical force F_v on top of railing (ft)

F_v = vertical force of vehicle laying on top of rail after impact forces F_r and F_l are over (kips)

CA13.4.3.1

Vehicle collision on the beam and post railing systems, such as a metal system with wide flange or tubular posts, imposes large concentrated forces and moments on the deck at the point where the post is attached to the deck.

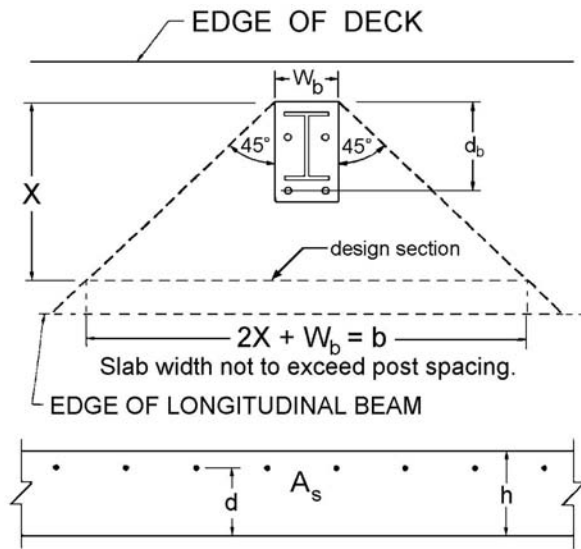

Figure A13.4.3.1-1—Effective Length of Cantilever for Carrying Concentrated Post Loads, Transverse or Vertical

A13.4.3.2—Resistance to Punching Shear

For Design Case 1, the factored shear may be taken as:

$$V_u = A_f F_y \quad (\text{A13.4.3.2-1})$$

The factored resistance of deck overhangs to punching shear may be taken as:

$$V_r = \phi V_n \quad (\text{A13.4.3.2-2})$$

$$V_n = v_c \left[W_b + h + 2 \left(E + \frac{B}{2} + \frac{h}{2} \right) \right] h \quad (\text{A13.4.3.2-3})$$

$$v_c = \left(0.0633 + \frac{0.1265}{\beta_c} \right) \sqrt{f'_c} \leq 0.1265 \sqrt{f'_c} \quad (\text{A13.4.3.2-4})$$

$$\frac{B}{2} + \frac{h}{2} \leq B \quad (\text{A13.4.3.2-5})$$

in which:

$$\beta_c = W_b / d_b \quad (\text{A13.4.3.2-6})$$

where:

V_u = factored shear force at section (kips)

A_f = area of post compression flange (in.²)

F_y = yield strength of post compression flange (ksi)

V_r = factored shear resistance (kips)

Previous editions of the Standard Specifications distributed railing or post loads to the slab using similar simplified analysis, e.g., “The effective length of slab resisting post loadings shall be equal to $E = 0.8x + 3.75$ ft where no parapet is used and equal to $E = 0.8x + 5.0$ ft where a parapet is used, where x is the distance in ft from the center of the post to the point under investigation.”

CA13.4.3.2

Concrete slabs or decks frequently fail in punching shear resulting from the force in the compression flange of the post, C . Adequate thickness, h , edge distance, E , or base plate size (W_b or B or thickness) should be provided to resist this type failure.

- V_n = nominal shear resistance of the section considered (kips)
- v_c = nominal shear resistance provided by tensile stresses in the concrete (ksi)
- W_b = width of base plate (in.)
- b = length of deck resisting post strength or shear load = $h + W_b$
- h = depth of slab (in.)
- E = distance from edge of slab to centroid of compressive stress resultant in post (in.)
- B = distance between centroids of tensile and compressive stress resultants in post (in.)
- β_c = ratio of the long side to the short side of the concentrated load or reaction area
- f'_c = 28-day compressive strength of concrete (ksi)
- ϕ = resistance factor = 1.0
- d_b = distance from the outer edge of the base plate to the innermost row of bolts (in.)

The assumed distribution of forces for punching shear shall be as shown in Figure A13.4.3.2-1.

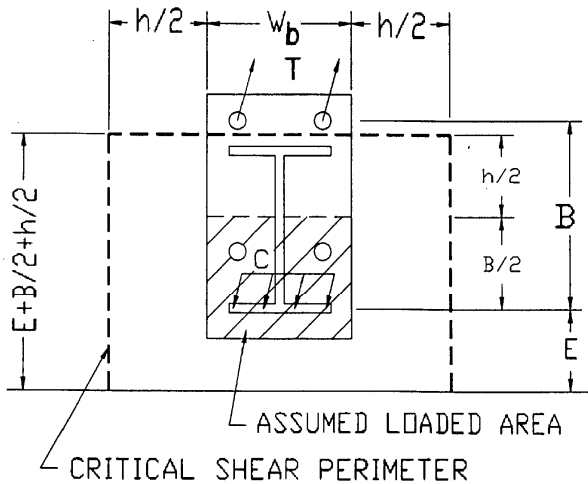

Test results and in-service experience have shown that where deck failures have occurred, the failure mode has been a punching shear-type failure with loss of structural integrity between the concrete and reinforcing steel. Use of various types of shear reinforcement may increase the ultimate strength of the postdeck connection but is ineffective in reducing shear, diagonal tension, or cracking in the deck. Shear resistance can be increased by increasing the slab thickness, base plate width and depth, or edge distance.

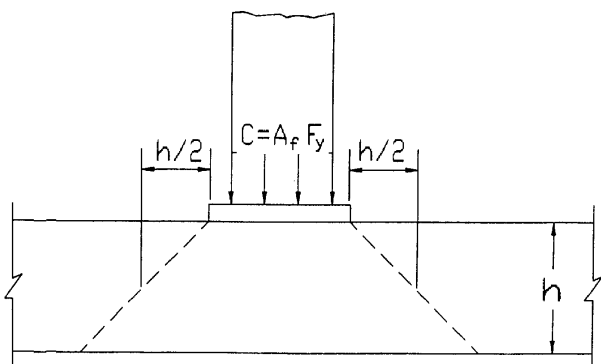

Figure A13.4.3.2-1—Punching Shear Failure Mode

SECTION 14: JOINTS AND BEARINGS

TABLE OF CONTENTS

14.1—SCOPE 14-1

14.2—DEFINITIONS 14-1

14.3—NOTATION 14-3

14.4—MOVEMENTS AND LOADS 14-6

 14.4.1—General 14-6

 14.4.2—Design Requirements 14-10

 14.4.2.1—Elastomeric Pads and Steel Reinforced Elastomeric Bearings 14-11

 14.4.2.2—High Load Multitrotational (HLMR) Bearings 14-12

 14.4.2.2.1—Pot Bearings and Curved Sliding Surface Bearings 14-12

 14.4.2.2.2—Disc Bearings 14-12

14.5—BRIDGE JOINTS 14-12

 14.5.1—Requirements 14-12

 14.5.1.1—General 14-12

 14.5.1.2—Structural Design 14-13

 14.5.1.3—Geometry 14-14

 14.5.1.4—Materials 14-14

 14.5.1.5—Maintenance 14-14

 14.5.2—Selection 14-14

 14.5.2.1—Number of Joints 14-14

 14.5.2.2—Location of Joints 14-15

 14.5.3—Design Requirements 14-15

 14.5.3.1—Movements during Construction 14-15

 14.5.3.2—Design Movements 14-16

 14.5.3.3—Protection 14-16

 14.5.3.4—Bridging Plates 14-17

 14.5.3.5—Armor 14-17

 14.5.3.6—Anchors 14-17

 14.5.3.7—Bolts 14-18

 14.5.4—Fabrication 14-18

 14.5.5—Installation 14-18

 14.5.5.1—Adjustment 14-18

 14.5.5.2—Temporary Supports 14-19

 14.5.5.3—Field Splices 14-19

 14.5.6—Considerations for Specific Joint Types 14-19

 14.5.6.1—Open Joints 14-19

 14.5.6.2—Closed Joints 14-20

 14.5.6.3—Waterproofed Joints 14-20

 14.5.6.4—Joint Seals 14-20

 14.5.6.5—Poured Seals 14-21

 14.5.6.6—Compression and Cellular Seals 14-21

14.5.6.7—Sheet and Strip Seals	14-21
14.5.6.8—Plank Seals	14-22
14.5.6.9—Modular Bridge Joint Systems (MBJS).....	14-22
14.5.6.9.1—General	14-22
14.5.6.9.2—Performance Requirements	14-24
14.5.6.9.3—Testing and Calculation Requirements.....	14-25
14.5.6.9.4—Loads and Load Factors	14-25
14.5.6.9.5—Distribution of Wheel Loads.....	14-27
14.5.6.9.6—Strength Limit State Design Requirements.....	14-28
14.5.6.9.7—Fatigue Limit State Design Requirements.....	14-29
14.5.6.9.7a—General	14-29
14.5.6.9.7b—Design Stress Range	14-31
14.6—REQUIREMENTS FOR BEARINGS.....	14-35
14.6.1—General	14-35
14.6.2—Characteristics	14-36
14.6.3—Force Effects Resulting from Restraint of Movement at the Bearing.....	14-37
14.6.3.1—Horizontal Force and Movement.....	14-37
14.6.3.2—Moment	14-38
14.6.4—Fabrication, Installation, Testing, and Shipping.....	14-40
14.6.5—Seismic and Other Extreme Event Provisions for Bearings	14-40
14.6.5.1—General	14-40
14.6.5.2—Applicability.....	14-40
14.6.5.3—Design Criteria	14-41
14.7—SPECIAL DESIGN PROVISIONS FOR BEARINGS	14-42
14.7.1—Metal Rocker and Roller Bearings	14-42
14.7.1.1—General	14-42
14.7.1.2—Materials	14-43
14.7.1.3—Geometric Requirements.....	14-43
14.7.1.4—Contact Stresses	14-43
14.7.2—PTFE Sliding Surfaces	14-44
14.7.2.1—PTFE Surface	14-44
14.7.2.2—Mating Surface.....	14-45
14.7.2.3—Minimum Thickness.....	14-45
14.7.2.3.1—PTFE	14-45
14.7.2.3.2—Stainless Steel Mating Surfaces	14-46
14.7.2.4—Contact Pressure.....	14-46
14.7.2.5—Coefficient of Friction.....	14-47
14.7.2.6—Attachment	14-48
14.7.2.6.1—PTFE	14-48
14.7.2.6.2—Mating Surface.....	14-48
14.7.3—Bearings with Curved Sliding Surfaces.....	14-49
14.7.3.1—General	14-49
14.7.3.2—Bearing Resistance	14-49
14.7.3.3—Resistance to Lateral Load	14-50

14.7.4—Pot Bearings.....	14-51
14.7.4.1—General.....	14-51
14.7.4.2—Materials.....	14-51
14.7.4.3—Geometric Requirements.....	14-51
14.7.4.4—Elastomeric Disc.....	14-53
14.7.4.5—Sealing Rings.....	14-53
14.7.4.5.1—General.....	14-53
14.7.4.5.2—Rings with Rectangular Cross-Sections.....	14-54
14.7.4.5.3—Rings with Circular Cross-Sections.....	14-54
14.7.4.6—Pot.....	14-54
14.7.4.7—Piston.....	14-55
14.7.5—Steel-Reinforced Elastomeric Bearings—Method B.....	14-56
14.7.5.1—General.....	14-56
14.7.5.2—Material Properties.....	14-58
14.7.5.3—Design Requirements.....	14-59
14.7.5.3.1—Scope.....	14-59
14.7.5.3.2—Shear Deformations.....	14-59
14.7.5.3.3—Combined Compression, Rotation, and Shear.....	14-60
14.7.5.3.4—Stability of Elastomeric Bearings.....	14-63
14.7.5.3.5—Reinforcement.....	14-64
14.7.5.3.6—Compressive Deflection.....	14-65
14.7.5.3.7—Seismic and Other Extreme Event Provisions.....	14-66
14.7.5.4—Anchorage for Bearings without Bonded External Plates.....	14-67
14.7.6—Elastomeric Pads and Steel-Reinforced Elastomeric Bearings—Method A.....	14-67
14.7.6.1—General.....	14-67
14.7.6.2—Material Properties.....	14-69
14.7.6.3—Design Requirements.....	14-70
14.7.6.3.1—Scope.....	14-70
14.7.6.3.2—Compressive Stress.....	14-70
14.7.6.3.3—Compressive Deflection.....	14-71
14.7.6.3.4—Shear.....	14-73
14.7.6.3.5—Rotation.....	14-73
14.7.6.3.5a—General.....	14-73
14.7.6.3.5b—Rotation of CDP.....	14-74
14.7.6.3.6—Stability.....	14-75
14.7.6.3.7—Reinforcement.....	14-75
14.7.6.3.8—Seismic and Other Extreme Event Provisions.....	14-75
14.7.7—Bronze or Copper Alloy Sliding Surfaces.....	14-76
14.7.7.1—Materials.....	14-76
14.7.7.2—Coefficient of Friction.....	14-77
14.7.7.3—Limit on Load.....	14-77
14.7.7.4—Clearances and Mating Surfaces.....	14-77
14.7.8—Disc Bearings.....	14-77
14.7.8.1—General.....	14-77
14.7.8.2—Materials.....	14-78

14.7.8.3—Elastomeric Disc	14-78
14.7.8.4—Shear Resisting Mechanism	14-79
14.7.8.5—Steel Plates	14-79
14.7.9—Guides and Restraints	14-79
14.7.9.1—General	14-79
14.7.9.2—Design Loads.....	14-80
14.7.9.3—Materials	14-80
14.7.9.4—Geometric Requirements.....	14-80
14.7.9.5—Design Basis.....	14-80
14.7.9.5.1—Load Location	14-80
14.7.9.5.2—Contact Stress.....	14-81
14.7.9.6—Attachment of Low-Friction Material	14-81
14.7.10—Other Bearing Systems.....	14-81
14.8—LOAD PLATES AND ANCHORAGE FOR BEARINGS	14-82
14.8.1—Plates for Load Distribution	14-82
14.8.2—Tapered Plates	14-83
14.8.3—Anchorage and Anchor Bolts	14-83
14.8.3.1—General	14-83
14.8.3.2—Seismic and Other Extreme Event Design and Detailing Requirements	14-84
14.9—CORROSION PROTECTION	14-84
14.10—REFERENCES	14-84

JOINTS AND BEARINGS

14.1—SCOPE

This Section contains requirements for the design and selection of structural bearings and deck joints.

Units used in this Section shall be taken as kip, in., rad., °F, and Shore Hardness, unless otherwise noted.

14.2—DEFINITIONS

Bearing—A structural device that transmits loads while facilitating translation and/or rotation.

Bearing Joint—A deck joint provided at bearings and other deck supports to facilitate horizontal translation and rotation of abutting structural elements. It may or may not provide for differential vertical translation of these elements.

Bronze Bearing—A bearing in which displacements or rotations take place by the sliding of a bronze surface against a mating surface.

Cotton-Duck-Reinforced Pad (CDP)—A pad made from closely spaced layers of elastomer and cotton-duck, bonded together during vulcanization.

Closed Joint—A deck joint designed to prevent the passage of debris through the joint and to safeguard pedestrian and cycle traffic.

Compression Seal—A preformed elastomeric device that is precompressed in the gap of a joint with expected total range of movement less than 2.0 in.

Construction Joint—A temporary joint used to permit sequential construction.

Cycle-Control Joint—A transverse approach slab joint designed to permit longitudinal cycling of integral bridges and attached approach slabs.

Damper—A device that transfers and reduces forces between superstructure elements and/or superstructure and substructure elements, while permitting thermal movements. The device provides damping by dissipating energy under seismic, braking, or other dynamic loads.

Deck Joint—A structural discontinuity between two elements, at least one of which is a deck element. It is designed to permit relative translation and/or rotation of abutting structural elements.

Disc Bearing—A bearing that accommodates rotation by deformation of a single elastomeric disc molded from a urethane compound. It may be movable, guided, unguided, or fixed. Movement is accommodated by sliding of polished stainless steel on PFTE.

Double Cylindrical Bearing—A bearing made from two cylindrical bearings placed on top of each other with their axes at right angles to facilitate rotation about any horizontal axis.

Fiberglass-Reinforced Pad (FGP)—A pad made from discrete layers of elastomer and woven fiberglass bonded together during vulcanization.

Fixed Bearing—A bearing that prevents differential longitudinal translation of abutting structural elements. It may or may not provide for differential lateral translation or rotation.

Integral Bridge—A bridge without deck joints.

Joint—A structural discontinuity between two elements. The structural members used to frame or form the discontinuity.

Joint Seal—A poured or preformed elastomeric device designed to prevent moisture and debris from penetrating joints.

Knuckle Bearing—A bearing in which a concave metal surface rocks on a convex metal surface to provide rotation capability about any horizontal axis.

Longitudinal—Parallel with the main span direction of a structure.

Longitudinal Joint—A joint parallel to the span direction of a structure provided to separate a deck or superstructure into two independent structural systems.

Metal Rocker or Roller Bearing—A bearing that carries vertical load by direct contact between two metal surfaces and that accommodates movement by rocking or rolling of one surface with respect to the other.

Modular Bridge Joint System (MBJS)—A sealed joint with two or more elastomeric seals held in place by edgebeams that are anchored to the structural elements (deck, abutment, etc.) and one or more transverse centerbeams that are parallel to the edgebeams. Typically used for movement ranges greater than 4.0 in.

Movable Bearing—A bearing that facilitates differential horizontal translation of abutting structural elements in a longitudinal and/or lateral direction. It may or may not provide for rotation.

Multirotational Bearing—A bearing consisting of a rotational element of the pot type, disc type, or spherical type when used as a fixed bearing and that may, in addition, have sliding surfaces to accommodate translation when used as an expansion bearing. Translation may be constrained to a specified direction by guide bars.

Neutral Point—The point about which all of the cyclic volumetric changes of a structure take place.

Open Joint—A joint designed to permit the passage of water and debris through the joint.

Plain Elastomeric Pad (PEP)—A pad made exclusively of elastomer, which provides limited translation and rotation.

Polytetrafluorethylene (PTFE)—Also known as Teflon.

Pot Bearing—A bearing that carries vertical load by compression of an elastomeric disc confined in a steel cylinder and that accommodates rotation by deformation of the disc.

Poured Seal—A seal made from a material that remains flexible (asphaltic, polymeric, or other), which is poured into the gap of a joint and is expected to adhere to the sides of the gap. Typically used only when expected total range of movement is less than 1.5 in.

PTFE Sliding Bearing—A bearing that carries vertical load through contact stresses between a PTFE sheet or woven fabric and its mating surface, and that permits movements by sliding of the PTFE over the mating surface.

Relief Joint—A deck joint, usually transverse, that is designed to minimize either unintended composite action or the effect of differential horizontal movement between a deck and its supporting structural system.

Restrainers—A system of high-strength cables or rods that transfers forces between superstructure elements and/or superstructure and substructure elements under seismic or other dynamic loads after an initial slack is taken up, while permitting thermal movements.

Root Mean Square—RMS

Rotation about the Longitudinal Axis—Rotation about an axis parallel to the main span direction of the bridge.

Rotation about the Transverse Axis—Rotation about an axis parallel to the transverse axis of the bridge.

Sealed Joint—A joint provided with a joint seal.

Shock Transmission Unit (STU)—A device that provides a temporary rigid link between superstructure elements and/or superstructure and substructure elements under seismic, braking, or other dynamic loads, while permitting thermal movements.

Single-Support-Bar System (SSB)—A MBS designed so that only one support bar is connected to all of the centerbeams. The centerbeam/support bar connection typically consists of a yoke through which the support bar slides.

Sliding Bearing—A bearing that accommodates movement by translation of one surface relative to another.

Steel-Reinforced Elastomeric Bearing—A bearing made from alternate laminates of steel and elastomer bonded together during vulcanization. Vertical loads are carried by compression of the elastomer. Movements parallel to the reinforcing layers and rotations are accommodated by deformation of the elastomer.

Strip Seal—A sealed joint with an extruded elastomeric seal retained by edgebeams that are anchored to the structural elements (deck, abutment, etc). Typically used for expected total movement ranges from 1.5 to 4.0 in., although single seals capable of spanning a 5.0 in. gap are also available.

Translation—Horizontal movement of the bridge in the longitudinal or transverse direction.

Transverse—The horizontal direction normal to the longitudinal axis of the bridge.

Waterproofed Joints—Open or closed joints that have been provided with some form of trough below the joint to contain and conduct deck discharge away from the structure.

Welded Multiple-Support-Bar System (WMSB)—A MBS designed so that each support bar is welded to only one centerbeam. Although some larger WMSB systems have been built and are performing well, WMSB systems are typically impractical for more than nine seals or for movement ranges larger than 27.0 in.

14.3—NOTATION

A	=	plan area of elastomeric element or bearing (in. ²) (14.6.3.1)
A_{Wbot}	=	area of weld at the bottom (in. ²) (14.5.6.9.7b)
A_{Wmid}	=	minimum cross-sectional area of weld (in. ²) (14.5.6.9.7b)
A_{Wtop}	=	area of weld at the top (in. ²) (14.5.6.9.7b)
a_{cr}	=	creep deflection divided by initial dead load deflection (14.7.5.3.6)
B_a	=	dimensionless coefficient used to determine peak hydrostatic stress (14.7.5.3.3)
C_α	=	parameter used to determine hydrostatic stress (14.7.5.3.3)
c	=	minimum vertical clearance between rotating and nonrotating parts (in.); design clearance between piston and pot (in.) (C14.7.3.1) (14.7.4.7)
D	=	diameter of the projection of the loaded surface of the bearing in the horizontal plane (in.); diameter of pad (in.); diameter of the bearing (in.) (14.7.3.2) (14.7.5.1) (14.7.6.3.6) (14.7.5.3.3) (14.7.5.3.4)
D_a	=	dimensionless coefficient used to determine shear strain due to axial load (14.7.5.3.3)
D_d	=	diameter of the disc element (in.) (14.7.8.1) (14.7.8.5)
D_p	=	internal diameter of pot (in.) (14.7.4.3) (14.7.4.6) (14.7.4.7)
D_r	=	dimensionless coefficient used to determine shear strain due to rotation (14.7.5.3.3)
D_1	=	diameter of the rocker or roller surface (in.) (14.7.1.4)
D_2	=	diameter of the mating surface, positive if the curvatures have the same sign, infinite if the mating surface is flat (in.) (14.7.1.4)
d	=	diameter of rocker or roller (in.); the diameter of the hole or holes in the bearing (in.) (C14.7.1.4) (C14.7.5.1)
d_{a1}	=	dimensionless coefficient used to determine shear strain due to axial load (C14.7.5.3.3)
d_{a2}	=	dimensionless coefficient used to determine shear strain due to axial load (C14.7.5.3.3)
d_{a3}	=	dimensionless coefficient used to determine shear strain due to axial load (C14.7.5.3.3)
d_{cb}	=	depth of the centerbeam (in.) (14.5.6.9.7b)
d_{sb}	=	depth of the support bar (in.) (14.5.6.9.7b)
E_c	=	effective modulus of elastomeric bearing in compression (ksi); uniaxial compressive stiffness of the CDP bearing pad. It may be taken as 30 ksi in lieu of pad specific test data (ksi) (14.6.3.2) (14.7.6.3.3) (14.7.6.3.5b)
E_s	=	Young's modulus for steel (ksi) (14.7.1.4)

F_y	=	specified minimum yield strength of the weakest steel at the contact surface (ksi); yield strength of steel (ksi); yield strength of steel reinforcement (ksi) (14.7.1.4) (14.7.4.6) (14.7.4.7) (14.7.5.3.5)
G	=	shear modulus of the elastomer (ksi); shear modulus of the CDP (14.6.3.1) (C14.6.3.2) (14.7.5.2) (14.7.5.3.3) (14.7.5.3.4) (C14.7.5.3.6) (14.7.6.2) (14.7.6.3.2) (14.7.6.3.4)
H_{bu}	=	lateral load transmitted to the superstructure and substructure by bearings from applicable strength and extreme event load combinations in Table 3.4.1-1 (kip) (14.6.3.1)
H_s	=	horizontal load from applicable service load combinations in Table 3.4.1-1 (kip) (14.7.3.3)
H_u	=	lateral load from applicable strength and extreme event load combinations in Table 3.4.1-1 (kip) (14.7.4.7)
h_{p1}	=	pot cavity depth (in.) (C14.7.4.3)
h_{p2}	=	vertical clearance between top of piston and top of pot wall (in.) (C14.7.4.3)
h_r	=	depth of elastomeric disc (in.) (14.7.4.3)
h_{ri}	=	thickness of i th elastomeric layer (in.); thickness of i th internal elastomeric layer (in.); layer thickness for FGP which equals the greatest distance between midpoints of two double fiberglass reinforcement layers (in.); thickness of a PEP (in.); mean thickness of two layers of elastomer bonded to the same reinforcement for FGP when the two layers are of different thicknesses (in.) (14.7.5.1) (14.7.5.3.6) (14.7.5.3.3) (14.7.5.3.5) (14.7.6.3.3) (14.7.6.3.7) (14.7.6.3.2)
h_{rt}	=	total elastomer thickness (in.); smaller of total elastomer or bearing thickness (in.) (14.6.3.1) (14.6.3.2) (14.7.5.3.2) (14.7.5.3.3) (14.7.5.3.4) (14.7.6.3.4)
h_s	=	thickness of steel reinforcement (in.) (14.7.5.3.5)
h_w	=	height of the weld (in.); height from top of rim to underside of piston (in.) (14.5.6.9.7b) (C14.7.4.3) (14.7.4.7)
I	=	moment of inertia of plan shape of bearing (in. ⁴) (14.6.3.2)
K	=	rotational stiffness of CDP (kip-in./rad.); bulk modulus (ksi) (C14.6.3.2) (C14.7.5.3.3)
L	=	projected length of the sliding surface perpendicular to the rotation axis (in.); plan dimension of the bearing perpendicular to the axis of rotation under consideration (generally parallel to the global longitudinal bridge axis) (in.); length of a CDP bearing pad in the plane of rotation (in.) (14.7.3.3) (14.7.5.1) (14.7.5.3.3) (14.7.5.3.4) (14.7.6.3.5b) (14.7.6.3.6)
M_H	=	horizontal bending moment range in the centerbeam on the critical section located at the weld toe due to horizontal force range (kip-in.) (14.5.6.9.7b)
M_{OT}	=	overturning moment range from horizontal reaction force (kip-in.) (14.5.6.9.7b)
M_V	=	vertical bending moment range in the centerbeam on the critical section located at the weld toe due to the vertical force range (kip-in.); component of vertical bending moment range in the support bar due to the vertical reaction force range in the connection located on the critical section at the weld toe (kip-in.) (14.5.6.9.7b)
M_u	=	moment transmitted to the superstructure and substructure by bearings from applicable strength and extreme event load combinations in Table 3.4.1-1 (kip-in.) (14.6.3.2)
m	=	modification factor (14.8.3.1) (5.7.5)
n	=	number of interior layers of elastomer (14.7.5.3.3) (14.7.5.4) (14.7.6.1)
P_D	=	compressive load at the service limit state (load factor = 1.0) due to permanent loads (kip) (14.7.3.3)
P_S	=	total compressive load from applicable service load combinations in Table 3.4.1-1 (kip) (14.7.1.4) (14.7.3.2)
P_u	=	compressive force from applicable strength and extreme event load combinations in Table 3.4.1-1 (kip) (14.6.3.1)
p	=	allowable bearing at the service limit state (kip/in.) (C14.7.1.4)
R	=	radius of curved sliding surface (in.) (14.6.3.2) (14.7.3.3)
R_H	=	horizontal reaction force range in the connection (kip) (14.5.6.9.7b)
R_o	=	radial distance from center of pot to object in question (e.g., pot wall, anchor bolt, etc.) (in.) (C14.7.4.3)
R_V	=	vertical reaction force range in the connection (kip) (14.5.6.9.7b)
S	=	shape factor of the CDP pad computed based on Eq. 14.7.5.1-1 and based on total pad thickness; shape factor of an individual elastomer layer; shape factor of PEP (14.6.3.2) (C14.7.5.3.6) (14.7.6.3.2)
S_i	=	shape factor of the i th layer of an elastomeric bearing; shape factor of the i th internal layer of an elastomeric bearing; shape factor for FGP based upon an h_{ri} layer thickness which equals the greatest distance between midpoints of two double fiberglass reinforcement layers (14.7.5.1) (14.7.5.3.3) (14.7.5.3.4) (14.7.5.4) (14.7.6.1) (14.7.6.3.2)
S_{RB}	=	combined bending stress range in the centerbeam (ksi); bending stress range in the support bar due to maximum moment including moment from vertical reaction and overturning at the connection (ksi) (14.5.6.9.7b)
S_{RZ}	=	vertical stress range in the top of the centerbeam-to-support-bar weld from the concurrent reaction of the support beam (ksi); vertical stress range in the bottom of the centerbeam-to-support-bar weld from the vertical and horizontal reaction force ranges in the connection (ksi) (14.5.6.9.7b)
S_{Wbot}	=	section modulus of the weld at the bottom for bending in the direction of the support bar axis (in. ³) (14.5.6.9.7b)

S_{Wmid}	=	section modulus of the weld at the most narrow cross-section for bending in the direction normal to the centerbeam axis (in. ³) (14.5.6.9.7b)
S_{Wtop}	=	section modulus of the weld at the top for bending in the direction normal to the centerbeam axis (in. ³) (14.5.6.9.7b)
S_{Xcb}	=	vertical section modulus to the bottom of the centerbeam (in. ³) (14.5.6.9.7b)
S_{Xsb}	=	vertical section modulus of the support bar to the top of the support bar (in. ³) (14.5.6.9.7b)
S_{Ycb}	=	horizontal section modulus of the centerbeam (in. ³) (14.5.6.9.7b)
t_b	=	pot base thickness (in.) (14.7.4.6) (14.7.4.7)
t_p	=	total thickness of CDP pad (in.) (14.6.3.2) (14.7.6.3.5b)
t_w	=	pot wall thickness (in.) (14.7.4.6) (14.7.4.7)
W	=	roadway surface gap in a transverse deck joint, measured in the direction of travel at the extreme movement determined using the appropriate strength load combination specified in Table 3.4.1-1 (in.); width of the bearing (in.); length of cylinder (in.); length of cylindrical surface (in.); plan dimension of the bearing parallel to the axis of rotation under consideration (generally parallel to the global transverse bridge axis) (in.) (14.5.3.2) (14.7.1.4) (14.7.3.2) (14.7.3.3) (14.7.5.1) (C14.7.5.3.3) (14.7.5.3.4) (14.7.6.3.6)
w	=	height of piston rim (in.) (14.7.4.7)
α	=	parameter used to determine hydrostatic stress (1/rad.) (14.7.5.3.3)
γ_a	=	shear strain caused by axial load (14.7.5.3.3)
$\gamma_{a,cy}$	=	shear strain caused by cyclic axial load (14.7.5.3.3)
$\gamma_{a,st}$	=	shear strain caused by static axial load (14.7.5.3.3)
γ_r	=	shear strain caused by rotation (14.7.5.3.3)
$\gamma_{r,cy}$	=	shear strain caused by rotation from cyclic loads (14.7.5.3.3)
$\gamma_{r,st}$	=	shear strain caused by rotation from static loads (14.7.5.3.3)
γ_s	=	shear strain caused by shear displacement (14.7.5.3.3)
$\gamma_{s,cy}$	=	shear strain caused by shear displacement from cyclic loads (14.7.5.3.3)
$\gamma_{s,st}$	=	shear strain caused by shear displacement from static loads (14.7.5.3.3)
β	=	angle between the vertical and resultant applied load (rad.) (14.7.3.3)
ΔF_{TH}	=	constant amplitude fatigue threshold taken from Table 6.6.1.2.5-3 for the detail category of interest (ksi); constant amplitude fatigue threshold for Category A as specified in Article 6.6 (14.5.6.9.7a) (14.7.5.3.5)
Δf	=	force effect, design live load stress range due to the simultaneous application of vertical and horizontal axle loads specified in Article 14.5.6.9.4 and distributed as specified in Article 14.5.6.9.5, and calculated as specified in Article 14.5.6.9.7b (ksi) (14.5.6.9.7a) (14.5.6.9.7b)
Δ_O	=	maximum horizontal displacement of the bridge superstructure at the service limit state (in.) (14.7.5.3.2)
Δ_S	=	maximum total shear deformation of the elastomer from applicable service load combinations in Table 3.4.1-1 (in.); maximum total shear deformation of the bearing from applicable service load combinations in Table 3.4.1-1 (in.); maximum total static or cyclic shear deformation of the elastomer from applicable service load combinations in Table 3.4.1-1 (in.) (14.7.5.3.2) (14.7.6.3.4) (14.7.5.3.3)
Δ_T	=	design thermal movement range computed in accordance with Article 3.12.2 (in.) (14.7.5.3.2)
Δ_u	=	shear deformation from applicable strength and extreme event load combinations in Table 3.4.1-1 (in.) (14.6.3.1)
δ_d	=	initial dead load compressive deflection (in.) (14.7.5.3.6)
δ_L	=	instantaneous live load compressive deflection (in.) (14.7.5.3.6)
δ_{lt}	=	long term dead load compressive deflection (in.) (14.7.5.3.6)
δ_u	=	vertical deflection from applicable strength load combinations in Table 3.4.1-1 (in.) (C14.7.4.3)
ϵ	=	compressive strain in an elastomer layer (C14.7.5.3.6)
ϵ_a	=	total of static and cyclic average axial strain taken as positive for compression in which the cyclic component is multiplied by 1.75 from applicable service load combinations in Table 3.4.1-1 (ksi) (14.7.5.3.3) (14.7.5.4)
ϵ_c	=	maximum uniaxial strain due to compression under total load from applicable service load combinations in Table 3.4.1-1 (14.7.6.3.5b)
ϵ_{di}	=	initial dead load compressive strain in i th elastomer layer (14.7.5.3.6)
ϵ_{Li}	=	instantaneous live load compressive strain in i th elastomer layer (14.7.5.3.6)
ϵ_s	=	average compressive strain due to total load from applicable service load combinations in Table 3.4.1-1 (14.7.6.3.3)
ϵ_t	=	maximum uniaxial strain due to combined compression and rotation from applicable service load combinations in Table 3.4.1-1 (14.7.6.3.5b)
θ_L	=	maximum rotation of the CDP pad at the service limit state (load factor = 1.0) due to live load (rad.) (14.7.6.3.5b)

- θ_s = maximum service limit state rotation due to total load for bearings unlikely to experience hard contact between metal components (rad.); maximum service limit state design rotation angle specified in Article 14.4.2.1 (rad.); maximum rotation of the CDP pad from applicable service load combinations in Table 3.4.1-1 (rad.); maximum service limit state design rotation angle about any axis of the pad specified in Article 14.4.2.1 (rad.); maximum static or cyclic service limit state design rotation angle of the elastomer specified in Article 14.4.2.1 (rad.); total of static and cyclic maximum service limit state design rotation angles of the elastomer specified in Article 14.4.2.1 in which the cyclic component is multiplied by 1.75 (rad.) (C14.4.2) (14.4.2.1) (14.6.3.2) (14.7.6.3.5b) (14.7.5.3.3) (14.7.5.4)
- θ_u = maximum strength limit state rotation for bearings that may experience hard contact between metal components (rad.); maximum strength limit state rotation for bearings which are less likely to experience hard contact between metal components (rad.); design rotation from applicable strength load combinations in Table 3.4.1-1 or Article 14.4.2.2.1 (rad.); maximum strength limit state design rotation angle specified in Article 14.4.2.2.1 (rad.); maximum strength limit state design rotation angle specified in Article 14.4.2.2.2 (rad.) (C14.4.2) (14.4.2.2.1) (14.4.2.2.2) (C14.7.3.1) (14.7.3.3) (14.7.4.3) (14.7.4.7) (14.7.8.1)
- λ = compressibility index (C14.7.5.3.3)
- μ = coefficient of friction; coefficient of friction of the PTFE slider (14.6.3.1) (C14.7.8.4)
- σ = instantaneous live load compressive stress or dead load compressive stress in an individual elastomer layer (ksi) (C14.7.5.3.6)
- σ_{hyd} = peak hydrostatic stress (ksi) (14.7.5.3.3)
- σ_L = average compressive stress at the service limit state (load factor = 1.0) due to live load (ksi) (14.7.5.3.5) (14.7.6.3.2)
- σ_s = average compressive stress due to total load from applicable service load combinations in Table 3.4.1-1 (ksi); average compressive stress due to total load associated with the maximum rotation from applicable service load combinations in Table 3.4.1-1 (ksi); average compressive stress due to total static or cyclic load from applicable service load combinations in Table 3.4.1-1 (ksi); total of static and cyclic average compressive stress in which the cyclic component is multiplied by 1.75 from applicable service load combinations in Table 3.4.1-1 (ksi) (14.7.4.6) (14.7.5.3.4) (14.7.5.3.5) (14.7.6.3.2) (14.7.6.3.3) (14.7.6.3.4) (14.6.3.2) (14.7.6.3.5b) (14.7.5.3.3)
- σ_{SS} = maximum average contact stress at the service limit state permitted on PTFE by Table 14.7.2.4-1 or on bronze by Table 14.7.7.3-1 (ksi) (14.7.3.2) (14.7.3.3)
- ϕ = resistance factor (14.6.1) (14.7.3.2) (C14.7.4.7)
- $\phi_{tension}$ = resistance factor for tension for anchors governed by the steel (14.5.6.9.6)
- ϕ_{shear} = resistance factor for shear for anchors governed by the steel (14.5.6.9.6)
- $\phi_{A\ tension}$ = resistance factor for tension for anchors governed by the concrete, Condition A, supplemental reinforcement in the failure area (14.5.6.9.6)
- $\phi_{A\ shear}$ = resistance factor for shear for anchors governed by the concrete, Condition A, supplemental reinforcement in the failure area (14.5.6.9.6)
- $\phi_{B\ tension}$ = resistance factor for tension for anchors governed by the concrete, Condition B, no supplemental reinforcement in the failure area (14.5.6.9.6)
- $\phi_{B\ shear}$ = resistance factor for shear for anchors governed by the concrete, Condition B, no supplemental reinforcement in the failure area (14.5.6.9.6)
- Ψ = subtended semiangle of the curved surface (rad.) (14.7.3.3)

14.4—MOVEMENTS AND LOADS

14.4.1—General

The selection and layout of the joints and bearings shall allow for deformations due to temperature and other time-dependent causes and shall be consistent with the proper functioning of the bridge.

Deck joints and bearings shall be designed to resist loads and accommodate movements at the service and strength limit states and to satisfy the requirements of the fatigue and fracture limit state. The loads induced on the joints, bearings, and structural members depend on the stiffness of the individual elements and the tolerances achieved during fabrication and erection. These influences

C14.4.1

The joints and bearings should allow movements due to temperature changes, creep and shrinkage, elastic shortening due to prestressing, traffic loading, construction tolerances or other effects. If these movements are restrained, large horizontal forces may result. If the bridge deck is cast-in-place or precast concrete, the bearings at a single support should permit transverse expansion and contraction. Externally applied transverse loads such as wind, earthquake, or traffic braking forces may be carried either on a small number of bearings near the centerline of the bridge or by an independent guide system. The latter is

shall be taken into account when calculating design loads for the elements. No damage due to joint or bearing movement shall be permitted at the service limit state, and no irreparable damage shall occur at the strength limit state. At the extreme event limit state, bearings which are designed to act as fuses or sustain irreparable damage may be permitted by the Owner provided loss of span is prevented.

Translational and rotational movements of the bridge shall be considered in the design of MBJS and bearings. The sequence of construction shall be considered, and all critical combinations of load and movement shall be considered in the design. Rotations about two horizontal axes and the vertical axis shall be considered. The movements shall include those caused by the loads, deformations, and displacements caused by creep, shrinkage and thermal effects, and inaccuracies in installation. In all cases, both instantaneous and long-term effects shall be considered. The influence of dynamic load allowance shall be included for MBJS, but need not be included for bearings. The most adverse combination shall be tabulated for the bearings in a rational form such as shown in Figure C14.4.1-1.

For determining force effects in joints, bearings, and adjacent structural elements, the influence of their stiffnesses and the expected tolerances achieved during fabrication and erection shall be considered.

The three-dimensional effects of translational and rotational movements of the bridge shall be considered in the design of MBJS and bearings.

Both instantaneous and long-term effects shall be considered in the design of joints and bearings.

The effects of curvature, skew, rotations, and support restraint shall be recognized in the analysis.

The forces resulting from transverse or longitudinal prestressing of the concrete deck or steel girders shall be considered in the design of the bearings.

likely to be needed if the horizontal forces are large and fusing or irreparable damage is not permitted.

See Article C14.6.5.3 for discussion concerning bearings which are designed to act as fuses at the extreme event limit state.

Distribution of vertical load among bearings may adversely affect individual bearings. This is particularly critical when the girders are stiff in bending and torsion and bearings are stiff in compression, and the construction method does not allow minor misalignments to be corrected.

Bridge movements arise from a number of different causes. Simplified estimates of bridge movements, particularly on bridges with complex geometry, may lead to improper estimation of the direction of motion and, as a result, an improper selection of the bearing or joint system. Curved and skewed bridges have transverse as well as longitudinal movement due to temperature effects and creep or shrinkage. Transverse movement of the superstructure relative to the substructure may become significant for very wide bridges. Relatively wide curved and skewed bridges often undergo significant diagonal thermal movement, which introduces large transverse movements or large transverse forces if the bridge is restrained against such movements. Rotations caused by permissible levels of misalignment during installation should also be considered, and in many cases they will be larger than the live load rotations.

The neutral axis of a girder that acts compositely with its bridge deck is typically close to the underside of the deck. As a result, the neutral axis of the beam and the center of rotation of the bearing seldom coincide. Under these conditions, end rotation of the girder induces either horizontal movements or forces at the bottom flange or bearing level. The location of bearings off the neutral axes of the girders can also create horizontal forces due to elastic shortening of the girders when subjected to vertical loads at continuous supports.

The failure of bridge bearings or joint seals may ultimately lead to deterioration or damage to the bridge.

Each bearing and MBJS should be clearly identified in design documents, and all requirements should be identified. One possible format for this information is shown in Figure C14.4.1-1 for limit states other than extreme event.

When integral piers or abutments are used, the substructure and superstructure are connected such that additional restraints against superstructure rotation are introduced.

In curved bridges, thermal stresses are minimized when bearings are oriented such that they permit free translation along rays from a single point. With bearings arranged to permit such movement along these rays, there will be no thermal forces generated when the superstructure temperature changes uniformly. Any other orientation of the bearings will induce thermal forces into the superstructure and substructure. However, other considerations often make impractical the orientation along rays from a single point.

Prestressing of the deck causes changes in the vertical reactions due to the eccentricity of the forces, which creates restoring forces. Effects of creep and shrinkage also should be considered.

Bridge name or ref.				
Bearing identification mark				
Number of bearings required				
Seating material	Upper surface			
	Lower surface			
Permitted average contact pressure (psi)	Service limit state	Upper face		
		Lower face		
Design load effects (kip)	Service limit state	Vertical	max.	
			perm.	
			min.	
			Transverse	
			Longitudinal	
	Strength limit state	Vertical		
Transverse				
Longitudinal				
Translation	Service limit state	Irreversible	Transverse	
			Longitudinal	
	Reversible	Transverse		
		Longitudinal		
	Strength limit state	Irreversible	Transverse	
			Longitudinal	
Reversible	Transverse			
	Longitudinal			

(continued on next page)

Figure C14.4.1-1—Typical Bridge Bearing Schedule

Rotation (rad.)	Service limit state	Irreversible	Transverse	
			Longitudinal	
		Reversible	Transverse	
			Longitudinal	
	Strength limit state	Irreversible	Transverse	
			Longitudinal	
		Reversible	Transverse	
			Longitudinal	
Maximum bearing dimensions (in.)	Upper surface		Transverse	
			Longitudinal	
	Lower surface		Transverse	
			Longitudinal	
	Overall height			
	Tolerable movement of bearing under transient loads (in.)			Vertical
Transverse				
Longitudinal				
Permitted resistance to translation under strength or service limit state as applicable (kip)			Transverse	
			Longitudinal	
Permitted resistance to rotation under strength or service limit state as applicable (kip/ft)			Transverse	
			Longitudinal	
Type of attachment to structure and substructure			Transverse	
			Longitudinal	

Figure C14.4.1-1 (continued)—Typical Bridge Bearing Schedule

14.4.2—Design Requirements

The minimum thermal movements shall be computed from the extreme temperature specified in Article 3.12.2 and the estimated setting temperatures. Design loads shall be based on the load combinations and load factors specified in Section 3.

C14.4.2

Rotations are considered at the service and strength limit states as appropriate for different types of bearings. Bearings must accommodate movements in addition to supporting loads, so displacements, and in particular rotations, are needed for design. Live load rotations are typically less than 0.005 rad., but the total rotation due to fabrication and setting tolerances for seats, bearings, and girders may be significantly larger than this. Therefore, the

total design rotation is found by summing rotations due to dead and live load and adding allowances for profile grade effects and the tolerances described above. Article 14.8.2 specifies when a tapered plate shall be used if the rotation due to permanent load at the service limit state (load factor = 1.0) becomes excessive. An Owner may reduce the fabrication and setting tolerance allowances if justified by a suitable quality control plan; therefore, these tolerance limits are stated as recommendations rather than absolute limits.

Failure of deformable components such as elastomeric bearings is generally governed by a gradual deterioration under many cycles of load rather than sudden failure under a single load application. Further, the design limits for elastomeric bearings were originally developed under ASD service load conditions rather than the strength limit state loads considered during development of the high load multirotational bearing systems. Unless smaller tolerances can be justified, θ_s for elastomeric components is the service limit state rotation plus 0.005 rad.

Metal or concrete components are susceptible to damage under a single rotation that causes metal-to-metal contact, and so they must be designed using the strength limit state rotations. Unless smaller tolerances can be justified, θ_u is the strength limit state rotation plus 0.01 rad.

Disc bearings are less likely to experience metal-to-metal contact than other High Load Multirotational (HLMR) bearings because the load element is unconfined. As a result, the total allowance for rotation is consequently smaller for a disc bearing than other HLMR bearings; however, the proof load test, as specified in the *AASHTO LRFD Bridge Construction Specifications*, assures against metal-to-metal contact.

14.4.2.1—Elastomeric Pads and Steel Reinforced Elastomeric Bearings

The maximum service limit state rotation due to total load, θ_s , for bearings unlikely to experience hard contact between metal components shall be taken as the sum of:

- The rotations from applicable service load combinations in Table 3.4.1-1, and
- An allowance for uncertainties, which shall be taken as 0.005 rad. unless an approved quality control plan justifies a smaller value.

The static and cyclic components of θ_s shall be considered separately when design is according to Article 14.7.5.3.3.

14.4.2.2—High Load Multirotational (HLMR) Bearings

14.4.2.2.1—Pot Bearings and Curved Sliding Surface Bearings

The maximum strength limit state rotation, θ_{us} , for bearings such as pot bearings and curved sliding surfaces that may potentially experience hard contact between metal components shall be taken as the sum of:

- The rotations from applicable strength load combinations in Table 3.4.1-1;
- The maximum rotation caused by fabrication and installation tolerances, which shall be taken as 0.005 rad. unless an approved quality control plan justifies a smaller value; and
- An allowance for uncertainties, which shall be taken as 0.005 rad. unless an approved quality control plan justifies a smaller value.

14.4.2.2.2—Disc Bearings

The maximum strength limit state rotation, θ_{us} , for disc bearings which are less likely to experience hard contact between metal components due to their unconfined load element, shall be taken as the sum of:

- The rotations from applicable strength load combinations in Table 3.4.1-1, and
- An allowance for uncertainties, which shall be taken as 0.005 rad. unless an approved quality control plan justifies a smaller value.

14.5—BRIDGE JOINTS

14.5.1—Requirements

14.5.1.1—General

Deck joints shall consist of components arranged to accommodate the translation and rotation of the structure at the joint.

The type of joints and surface gaps shall accommodate the movement of motorcycles, bicycles, and pedestrians, as required, and shall neither significantly impair the riding characteristics of the roadway nor cause damage to vehicles.

The joints shall be detailed to prevent damage to the structure from water, deicing chemicals, and roadway debris.

Longitudinal deck joints shall be provided only where necessary to modify the effects of differential lateral and/or vertical movement between the superstructure and substructure.

Joints and joint anchors for grid and timber decks and orthotropic deck superstructures require special details.

C14.5.1.1

To accommodate differential lateral movement, elastomeric bearings or combination bearings with the capacity for lateral movement should be used instead of longitudinal joints where practical.

14.5.1.2—Structural Design

Joints and their supports shall be designed to withstand force effects for the appropriate design limit state or states over the range of movements for the appropriate design limit state or states, as specified in Section 3. Resistance factors and modifiers shall be taken as specified in Sections 1, 5, 6, 7, and 8, as appropriate.

In snow regions, joint armor, armor connections, and anchors shall be designed to resist force effects that may be imposed on the joints by snagging snowplow blades. The edgebeams and anchorages of strip seals and MBS with a skew exceeding 20 degrees in snow regions that do not incorporate protection methods such as those discussed in Article 14.5.3.3 shall be designed for the strength limit state with a minimum snowplow load acting as a horizontal line load on the top surface of the edgebeam in a direction perpendicular to the edgebeam of 0.12 kips/in. for a total length of 10.0 ft anywhere along the edgebeam in either direction. This load includes dynamic load allowance.

The following factors shall be considered in determining force effects and movements:

- Properties of materials in the structure, including coefficient of thermal expansion, modulus of elasticity, and Poisson's ratio;
- Effects of temperature, creep, and shrinkage;
- Sizes of structural components;
- Construction tolerances;
- Method and sequence of construction;
- Skew and curvature;
- Resistance of the joints to movements;
- Approach pavement growth;
- Substructure movements due to embankment construction;
- Foundation movements associated with the consolidation and stabilization of subsoils;
- Structural restraints; and
- Static and dynamic structural responses and their interaction.

C14.5.1.2

The strength limit state for the edgebeams of strip seals and MBS and anchorage to the concrete or other elements should be checked with this snowplow load if the skew of the joint exceeds 20 degrees relative to a line transverse to the traveling direction. For smaller skews, the blades, which are skewed, will not strike an edgebeam all at once. Protection methods such as those discussed in Article 14.5.3.3 may eliminate the need to design for this snowplow load.

Snowplow blade angles vary regionally. Unless protection methods such as those discussed in Article 14.5.3.3 are used, agencies should avoid MBS installations with skew that is within three degrees of the plow angle used in that region, to avoid having the plow drop into the gap between centerbeams.

The snowplow load was estimated from snowplow manufacturer information as the force required to deflect a spring-activated blade with 2.0 in. of compression and ten degrees of deflection. The snowplow load includes the effect of impact so the dynamic load allowance should not be applied. The snowplow load should be multiplied by the appropriate strength limit state load factor for live load.

Superstructure movements include those due to placement of bridge decks, volumetric changes, such as shrinkage, temperature, moisture and creep, passage of vehicular and pedestrian traffic, pressure of wind, and the action of earthquakes. Substructure movements include differential settlement of piers and abutments, tilting, flexure, and horizontal translation of wall-type abutments responding to the placement of backfill as well as shifting of stub abutments due to the consolidation of embankments and in-situ soils.

Any horizontal movement of a bridge superstructure will be opposed by the resistance of bridge bearings to movement and the rigidity or flexural resistance of substructure elements. The rolling resistance of rocker and rollers, the shear resistance of elastomeric bearings, or the frictional resistance of bearing sliding surfaces will oppose movement. In addition, the rigidity of abutments and the relative flexibility of piers of various heights and foundation types will affect the magnitude of bearing movement and the bearing forces opposing movement.

Rigid approach pavements composed of cobblestone, brick, or jointed concrete will experience growth or substantial longitudinal pressure due to restrained growth. To protect bridge structures from these potentially destructive pressures and to preserve the movement range of deck joints and the performance of joint seals, either effective pavement pressure relief joints or pavement anchors should be provided in approach pavements, as described in *Transportation Research Record 1113*.

The length of superstructure affecting the movement at one of its joints shall be the length from the joint being considered to the structure's neutral point.

For a curved superstructure that is laterally unrestrained by guided bearings, the direction of longitudinal movement at a bearing joint may be assumed to be parallel to the chord of the deck centerline taken from the joint to the neutral point of the structure.

The potential for unaligned longitudinal and rotational movement of the superstructure at a joint should be considered in designing the vertical joints in curbs and raised barriers and in determining the appropriate position and orientation of closure or bridging plates.

14.5.1.3—Geometry

The moving surfaces of the joint shall be designed to work in concert with the bearings to avoid binding the joints and adversely affecting force effects imposed on bearings.

14.5.1.4—Materials

The materials shall be selected so as to ensure that they are elastically, thermally, and chemically compatible. Where substantial differences exist, material interfaces shall be formulated to provide fully functional systems.

Materials, other than elastomers, should have a service life of not less than 75 yr. Elastomers for joint seals and troughs should provide a service life not less than 25 yr.

Joints exposed to traffic should have a skid-resistant surface treatment, and all parts shall be resistant to attrition and vehicular impact.

Except for high-strength bolts, fasteners for joints exposed to deicing chemicals shall be made of stainless steel.

14.5.1.5—Maintenance

Deck joints shall be designed to operate with a minimum of maintenance for the design life of the bridge.

Detailing should permit access to the joints from below the deck and provide sufficient area for maintenance.

Mechanical and elastomeric components of the joint shall be replaceable.

Joints shall be designed to facilitate vertical extension to accommodate roadway overlays.

14.5.2—Selection

14.5.2.1—Number of Joints

The number of movable deck joints in a structure should be minimized. Preference shall be given to continuous deck systems and superstructures and, where appropriate, integral bridges.

When horizontal movement at the ends of a superstructure is due to volumetric changes, the forces generated within the structure in resistance to these changes are balanced. The neutral point can be located by estimating these forces, taking into account the relative resistance of bearings and substructures to movement. The length of superstructure contributing to movement at a particular joint can then be determined.

C14.5.1.3

For square or slightly skewed bridge layouts, moderate roadway grades at the joint and minimum changes in both horizontal and vertical joint alignment may be preferred in order to simplify the movements of joints and to enhance the performance of the structure.

C14.5.1.4

Preference should be given to those materials that are least sensitive to field compounding and installation variables and to those that can be repaired and altered by nonspecialized maintenance forces. Preference should also be given to those components and devices that will likely be available when replacements are needed.

C14.5.1.5

The position of bearings, structural components, joints and abutment backwalls, and the configuration of pier tops should be chosen so as to provide sufficient space and convenient access to joints from below the deck. Inspection hatches, ladders, platforms, and/or catwalks shall be provided for the deck joints of large bridges not directly accessible from the ground.

C14.5.2.1

Integral bridges, bridges without movable deck joints, should be considered where the length of superstructure and flexibility of substructures are such that secondary stresses due to restrained movement are controlled within tolerable limits.

The need for a fully functional cycle-control joint shall be investigated on approaches of integral bridges.

Movable joints may be provided at abutments of single-span structures exposed to appreciable differential settlement. Intermediate deck joints should be considered for multiple-span bridges where differential settlement would result in significant overstresses.

14.5.2.2—Location of Joints

Deck joints should be avoided over roadways, railroads, sidewalks, other public areas, and at the low point of sag vertical curves.

Deck joints should be positioned with respect to abutment backwalls and wingwalls to prevent the discharge of deck drainage that accumulates in the joint recesses onto bridge seats.

Open deck joints should be located only where drainage can be directed to bypass the bearings and discharged directly below the joint.

Closed or waterproof deck joints should be provided where joints are located directly above structural members and bearings that would be adversely affected by debris accumulation. Where deicing chemicals are used on bridge decks, sealed or waterproofed joints should be provided.

For straight bridges, the longitudinal elements of deck joints, such as plate fingers, curb and barrier plates, and modular bridge joint system support bars, should be placed parallel to the longitudinal axis of the deck. For curved and skewed structures, allowance shall be made for deck end movements consistent with that provided by the bearings.

Where possible, modular bridge joint systems should not be located in the middle of curved bridges to avoid unforeseeable movement demands. Preferably, modular bridge joint systems should not be located near traffic signals or toll areas so as to avoid extreme braking forces.

14.5.3—Design Requirements

14.5.3.1—Movements during Construction

Where practicable, construction staging should be used to delay construction of abutments and piers located in or adjacent to embankments until the embankments have been placed and consolidated. Otherwise, deck joints should be sized to accommodate the probable abutment and pier movements resulting from embankment consolidation after their construction.

Where a floorbeam design that can tolerate differential longitudinal movements resulting from relative temperature and live load response of the deck and independent supporting members, such as girders and trusses, is not practical, relief joints in the deck slab, movable joints in the stringers, and movable bearings between the stringers and floorbeams should be used.

Long-span deck-type structures with steel stringers that are slightly skewed, continuous, and composite can withstand substantial differential settlement without significant secondary stresses. Consequently, intermediate deck joints are rarely necessary for multiple-span bridges supported by secure foundations, i.e., piles, bedrock, dense subsoils, etc. Because the stresses induced by settlement can alter the point of inflection, a more conservative control of fatigue-prone detail locations is appropriate.

Guidance on the movements of the substructure can be found in Articles 10.5.2, 10.6.2, 10.7.2, and 10.8.2.

C14.5.2.2

Open joints with drainage troughs should not be placed where the use of horizontal drainage conductors would be necessary.

End rotations of deck-type structures occur about axes that are roughly parallel to the centerline of bearings along the bridge seat. In skewed structures, these axes are not normal to the direction of longitudinal movement. Sufficient lateral clearances between plates, open joints, or elastomeric joint devices should be provided to prevent binding due to lack of alignment between longitudinal and rotational movements.

C14.5.3.1

Where it is either desirable or necessary to accommodate settlement or other construction movements prior to deck joint installation and adjustment, the following construction controls may be used:

- Placing abutment embankment prior to pier and abutment excavation and construction,

Closure pours in concrete structures may be used to minimize the effect of prestress-induced shortening on the width of seals and the size of bearings.

- Surcharging embankments to accelerate consolidation and adjustment of in-situ soils,
- Backfilling wall-type abutments up to subgrade prior to placing bearings and backwalls above bridge seats, and
- Using deck slab blockouts to allow placing the major portion of span dead loads prior to joint installation.

14.5.3.2—Design Movements

A roadway surface gap, W , in in., in a transverse deck joint, measured in the direction of travel at the maximum movement determined using the appropriate strength load combination specified in Table 3.4.1-1 shall satisfy:

- For single gap:

$$W \leq 4.0 \text{ in.} \quad (14.5.3.2-1)$$

- For multiple modular gaps:

$$W \leq 3.0 \text{ in.} \quad (14.5.3.2-2)$$

For steel and nonprestressed wood superstructures, the minimum opening of a transverse deck joint and roadway surface gap therein shall not be less than 1.0 in. for movements determined using the appropriate strength load combination specified in Table 3.4.1-1. For concrete superstructures, consideration shall be given to the opening of joints due to creep and shrinkage that may require initial minimum openings of less than 1.0 in. at the strength limit state.

Unless more appropriate criteria are available, the maximum surface gap of longitudinal roadway joints shall not exceed 1.0 in. at the strength limit state.

At the maximum movement determined using the appropriate strength load combination specified in Table 3.4.1-1, the opening between adjacent fingers on a finger plate shall not exceed:

- 2.0 in. for longitudinal openings greater than 8.0 in., or
- 3.0 in. for longitudinal openings 8.0 in. or less.

The finger overlap at the maximum movement shall be not less than 1.5 in. at the strength limit state.

Where bicycles are anticipated in the roadway, the use of special covering floor plates in shoulder areas shall be considered.

14.5.3.3—Protection

Deck joints shall be designed to accommodate the effects of vehicular traffic, pavement maintenance equipment, and other long-term environmentally induced damage.

Joints in concrete decks should be armored with steel shapes, weldments, or castings. Such armor shall be recessed below roadway surfaces and be protected from snowplows.

C14.5.3.2

Safe operation of motorcycles is one of the prime considerations in choosing the size of openings for finger plate joints.

C14.5.3.3

Snowplow protection for deck joint armor and joint seals may consist of:

Jointed approach pavements shall be provided with pressure relief joints and/or pavement anchors. Approaches to integral bridges shall be provided with cycle control pavement joints.

- Concrete buffer strips 12.0 to 18.0 in. wide with joint armor recessed 0.25 to 0.375 in. below the surface of such strips,
- Tapered steel ribs protruding up to 0.50 in. above roadway surfaces to lift the plow blades as they pass over the joints,
- Recesses in flexible pavement to position armor below anticipated rutting, but not so deep as to pond water.

Additional precautions to prevent damage by snowplows should be considered where the skew of the joints coincides with the skew of the plow blades, typically 30 degrees to 35 degrees.

14.5.3.4—Bridging Plates

Joint bridging plates and finger plates should be designed as cantilever members capable of supporting wheel loads at the strength limit state.

The differential settlement between the two sides of a joint bridging plate shall be investigated. If the differential settlement cannot be either reduced to acceptable levels or accommodated in the design and detailing of the bridging plates and their supports, a more suitable joint should be used.

Rigid bridging plates shall not be used at elastomeric bearings or hangers unless they are designed as cantilever members, and the contract documents require them to be installed to prevent binding of the joints due to horizontal and vertical movement at bearings.

C14.5.3.4

Where binding of bridging plates can occur at bearing joints due to differential vertical translation of abutting structural elements or due to the longitudinal movement of bridging plates and bearings on different planes, the plates can be subjected to the total dead and live load superstructure reaction. Where bridging plates are not capable of resisting such loads, they may fail and become a hazard to the movement of vehicular traffic.

Thick elastomeric bearings responding to the application of vertical load or short hangers responding to longitudinal deck movements may cause appreciable differential vertical translation of abutting structural elements at bearing joints. To accommodate such movements, an appropriate type of sealed joint or a waterproofed open joint, rather than a structural joint with rigid bridging plates or fingers, should be provided.

14.5.3.5—Armor

Joint-edge armor embedded in concrete substrates should be pierced by 0.75-in. minimum-diameter vertical vent holes spaced on not more than 18.0-in. centers.

Metal surfaces wider than 12.0 in. that are exposed to vehicular traffic shall be provided with an antiskid treatment.

C14.5.3.5

Vent holes are necessary to help expel entrapped air and facilitate the attainment of a solid concrete substrate under joint edge armor.

The contract documents should require hand packing of concrete under joint armor.

14.5.3.6—Anchors

Armor anchors or shear connectors should be provided to ensure composite behavior between the concrete substrate and the joint hardware and to prevent subsurface corrosion by sealing the boundaries between the armor and concrete substrate. Anchors for edgebeams of strip seals and MBS shall be designed for the snowplow load as required in Article 14.5.1.2.

C14.5.3.6

Snow plow impact should also be considered in designing anchors.

Anchors for roadway joint armor shall be directly connected to structural supports or extended to effectively engage the reinforced concrete substrate.

The free edges of roadway armor, more than 3.0 in. from other anchors or attachments, shall be provided with 0.50-in. diameter end-welded studs not less than 4.0 in. long spaced at not more than 12.0 in. from other anchors or attachments. The edges of sidewalk and barrier armor shall be similarly anchored.

14.5.3.7—Bolts

Anchor bolts for bridging plates, joint seals, and joint anchors shall be fully torqued high-strength bolts. The interbedding of nonmetallic substrates in connections with high-strength bolts shall be avoided. Cast-in-place anchors shall be used in new concrete. Expansion anchors, countersunk anchor bolts, and grouted anchors shall not be used in new construction.

14.5.4—Fabrication

Shapes or plates shall be of sufficient thickness to stiffen the assembly and minimize distortion due to welding.

To ensure appropriate fit and function, the contract documents should require that:

- Joint components be fully assembled in the shop for inspection and approval,
- Joints and seals be shipped to the job-site fully assembled, and
- Assembled joints in lengths up to 60.0 ft be furnished without intermediate field splices.

14.5.5—Installation

14.5.5.1—Adjustment

The setting temperature of the bridge or any component thereof shall be taken as the actual air temperature averaged over the 24-hour period immediately preceding the setting event.

For long structures, an allowance shall be included in the specified joint widths to account for the inaccuracies inherent in establishing installation temperatures and for superstructure movements that may take place during the time between the setting of the joint width and completion of joint installation. In the design of joints for long structures, preference should be given to those devices, details, and procedures that will allow joint adjustment and completion in the shortest possible time.

C14.5.3.7

Grouted anchors may be used for maintenance of existing joints.

C14.5.4

Joint straightness and fit of components should be enhanced by the use of shapes, bars, and plates 0.50 in. or thicker.

Construction procedures and practices should be developed to allow joint adjustment for installation temperatures without altering the orientation of joint parts established during shop assembly.

C14.5.5.1

Except for short bridges where installation temperature variations would have only a negligible effect on joint width, plans for each expansion joint should include required joint installation widths for a range of probable installation temperatures. For concrete structures, use of a concrete thermometer and measurement of temperature in expansion joints between superstructure units may be considered.

An offset chart for installation of the expansion joints is recommended to account for uncertainty in the setting temperature at the time of design. The designer may provide offset charts in appropriate increments and include the chart on the design drawings. Placement of the expansion joint hardware during deck forming should accommodate differences between setting temperature and an assumed design installation temperature.

Connections of joint supports to primary members should allow horizontal, vertical, and rotational adjustments.

Construction joints and blockouts should be used where practicable to permit the placement of backfill and the major structure components prior to joint placement and adjustment.

14.5.5.2—Temporary Supports

Deck joints shall be furnished with temporary devices to support joint components in proper position until permanent connections are made or until encasing concrete has achieved an initial set. Such supports shall provide for adjustment of joint widths for variations in installation temperatures.

14.5.5.3—Field Splices

Joint designs shall include details for transverse field splices for staged construction and for joints longer than 60.0 ft. Where practicable, splices should be located outside of wheel paths and gutter areas.

Details in splices should be selected to maximize fatigue life.

Field splices provided for staged construction shall be located with respect to other construction joints to provide sufficient room to make splice connections.

When a field splice is required, the contract documents should require that permanent seals not be placed until after joint installation has been completed. Where practicable, only those seals that can be installed in one continuous piece should be used. Where field splicing is unavoidable, splices should be vulcanized.

14.5.6—Considerations for Specific Joint Types

14.5.6.1—Open Joints

Open deck joints shall permit the free flow of water through the joint. Open deck joints should not be used where deicing chemicals are applied. Piers and abutments at open joints shall satisfy the requirements of Article 2.5.2 in order to prevent the accumulation of water and debris.

Construction procedures that will allow major structure dead load movements to occur prior to placement and adjustment of deck joints should be used.

C14.5.5.2

Temporary attachments should be released to avoid damaging anchorage encasements due to movement of superstructures responding to rapid temperature changes.

For long structures with steel primary members, instructions should be included in the contract documents to ensure the removal of temporary supports or release of their connections as soon as possible after concrete placement.

C14.5.5.3

Splices for less critical portions of joints or for lightly loaded joints should be provided with connections rigid enough to withstand displacement if joint armor is used as a form during concrete placement.

C14.5.6.1

Under certain conditions, open deck joints can provide an effective and economical solution. In general, open joints are well-suited for secondary highways where little sand and salt are applied during the winter. They are not suited for urban areas where the costs of provisions for deck joint drainage are high.

Satisfactory performance depends upon an effective deck drainage system, control of deck discharge through joints, and containment and disposal of runoff from the site. It is essential that surface drainage and roadway debris not be permitted to accumulate on any part of the structure below such joints.

Protection against the deleterious effects of deck drainage may include shaping structural surfaces to prevent the retention of roadway debris and providing surfaces with deflectors, shields, covers, and coatings.

14.5.6.2—Closed Joints

Sealed deck joints shall seal the surface of the deck, including curbs, sidewalks, medians, and, where necessary, parapet and barrier walls. The sealed deck joint shall prevent the accumulation of water and debris, which may restrict its operation. Closed or waterproof joints exposed to roadway drainage shall have structure surfaces below the joint shaped and protected as required for open joints.

Joint seals should be watertight and extrude debris when closing.

Drainage accumulated in joint recesses and seal depressions shall not be discharged on bridge seats or other horizontal portions of the structure.

Where joint movement is accommodated by a change in the geometry of elastomeric glands or membranes, the glands or membranes shall not come into direct contact with the wheels of vehicles.

14.5.6.3—Waterproofed Joints

Waterproofing systems for joints, including joint troughs, collectors, and downspouts, shall be designed to collect, conduct, and discharge deck drainage away from the structure.

In the design of drainage troughs, consideration should be given to:

- Trough slopes of not less than 1.0 in./ft;
- Open-ended troughs or troughs with large discharge openings;
- Prefabricated troughs;
- Troughs composed of reinforced elastomers, stainless steel, or other metal with durable coatings;
- Stainless steel fasteners;
- Troughs that are replaceable from below the joint;
- Troughs that can be flushed from the roadway surface; and
- Welded metal joints and vulcanized elastomeric splices.

14.5.6.4—Joint Seals

Seals shall accommodate all anticipated movements.

In the choice of a seal type, consideration should be given to seals that:

- Are preformed or prefabricated,
- Can be replaced without major joint modification,
- Do not support vehicular wheel loads,
- Can be placed in one continuous piece,
- Are recessed below joint armor surface,

C14.5.6.2

Completely effective joint seals have yet to be developed for some situations, particularly where there are severely skewed joints with raised curbs or barriers, and especially where joints are subjected to substantial movements. Consequently, some type of open or closed joint, protected as appropriate, should be considered instead of a sealed joint.

Sheet and strip seals that are depressed below the roadway surface and that are shaped like gutters will fill with debris. They may burst upon closing, unless the joints that they seal are extended straight to the deck edges where accumulated water and debris can be discharged clear of the structure. To allow this extension and safe discharge, it may be necessary to move the backwalls and bridge seats of some abutment types forward until the backwalls are flush with the wingwalls, or to reposition the wingwalls so that they do not obstruct the ends of the deck joints.

- Are mechanically anchored, and
- Respond to joint width changes without substantial resistance.

Elastomeric material for seals should be:

- Durable, of virgin neoprene or natural rubber and reinforced with steel or fabric laminates;
- Vulcanized;
- Verified by long-term cyclic testing; and
- Connected by adhesives that are chemically cured.

14.5.6.5—Poured Seals

Unless data supports a smaller joint width, the joint width for poured seals should be at least 6.0 times the anticipated joint movement determined using the appropriate strength load combination specified in Table 3.4.1-1.

Sealant bond to metal and masonry materials should be documented by national test methods.

14.5.6.6—Compression and Cellular Seals

Where seals with heavy webbing are exposed to the full movement range, joints shall not be skewed more than 20 degrees.

Compression seals for bearing joints shall not be less than 2.5 in. nor more than 6.0 in. wide when uncompressed and shall be specified in width increments in multiples of 0.5 in.

Primary roadway seals shall be furnished without splices or cuts, unless specifically approved by the Engineer.

In gutter and curb areas, roadway seals shall be bent up in gradual curves to retain roadway drainage. Ends of roadway seals shall be protected by securely attached vented caps or covers. Secondary seals in curbs and barrier areas may be cut and bent as necessary to aid in bending and insertion into the joint.

Closed cell seals shall not be used in joints where they would be subjected to sustained compression, unless seal and adhesive adequacy have been documented by long-term demonstration tests for similar applications.

14.5.6.7—Sheet and Strip Seals

In the selection and application of either sheet or strip seals, consideration should be given to:

- Joint designs for which glands with anchorages not exposed to vehicular loadings,
- Joint designs that allow complete closure without detrimental effects to the glands,
- Joint designs where the elastomeric glands extend straight to deck edges rather than being bent up at curbs or barriers,

C14.5.6.5

Poured seals should be used only for joints exposed to small movements and for applications where watertightness is of secondary importance.

C14.5.6.6

Compression seals should be used only in those structures where the joint movement range can be accurately predicted.

Performance of compression and cellular seals is improved when concrete joint recesses are made by saw-cutting in a single pass, rather than by being cast with the aid of removable forms.

- Decks with sufficient crown or superelevation to ensure lateral drainage of accumulated water and debris,
- Glands that are shaped to expel debris, and
- Glands without abrupt changes in either horizontal or vertical alignment.

Sheet and strip seals should be spliced only when specifically approved by the engineer.

14.5.6.8—Plank Seals

Application of plank seals should be limited to structures on secondary roads with light truck traffic, and that have unskewed or slightly skewed joints.

Consideration should be given to:

- Seals that are provided in one continuous piece for the length of the joint,
- Seals with splices that are vulcanized, and
- Anchorages that can withstand the forces necessary to stretch or compress the seal.

14.5.6.9—Modular Bridge Joint Systems (MBJS)

14.5.6.9.1—General

These Articles of the specifications address the performance requirements, strength limit state design, and fatigue limit state design of modular bridge joint systems (MBJS).

These Specifications were developed primarily for, and shall be applied to, the two common types of MBJS, multiple and single support bar systems, including swivel-joint systems.

C14.5.6.8

Plank-type seals should not be used in joints with unpredictable movement ranges.

C14.5.6.9.1

These MBJS design specifications provide a rational and conservative method for the design of the main load carrying steel components of MBJS. These Specifications do not specifically address the functional design of MBJS or the design of the elastomeric parts. These Specifications are based on research described in Dexter et al. (1997), which contains extensive discussion of the loads and measured dynamic response of MBJS and the fatigue resistance of common MBJS details. Fatigue test procedures were developed for the structural details as well.

Common types of MBJS are shown in Figures C14.5.6.9.1-1 through C14.5.6.9.1-3.

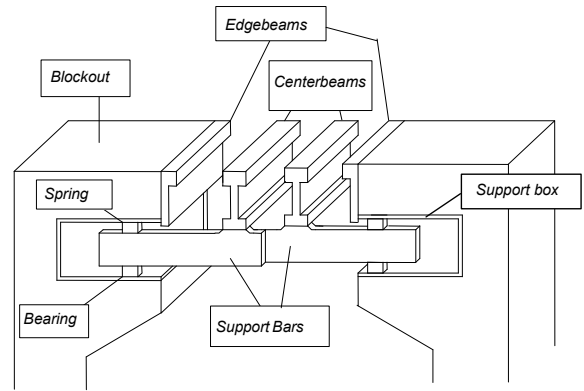

Figure C14.5.6.9.1-1—Cut-Away View of Typical Welded-Multiple-Support-Bar (WMSB) Modular Bridge Joint System (MBJS) Showing Support Bars Sliding within Support Boxes

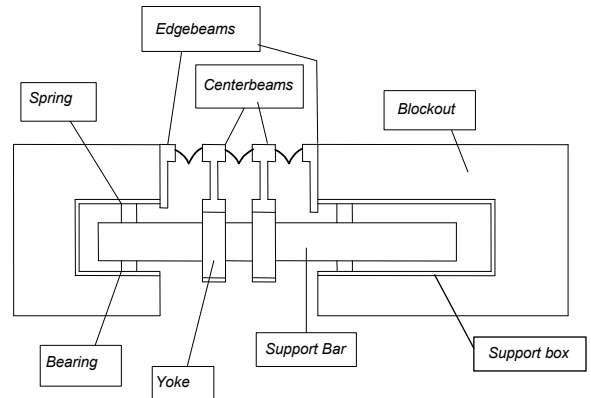

Figure C14.5.6.9.1-2—Cross-Section View of Typical Single-Support-Bar (SSB) Modular Bridge Joint System (MBJS) Showing Multiple Centerbeams with Yokes Sliding on a Single Support Bar

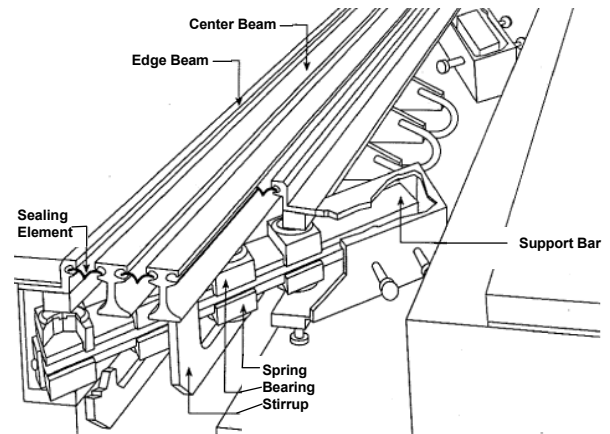

Figure C14.5.6.9.1-3—Cut-Away View of a “Swivel Joint,” i.e., a Special Type of Single-Support-Bar (SSB) Modular Bridge Joint System (MBJS) with a Swiveling Single Support Bar

14.5.6.9.2—Performance Requirements

The required minimum MBJS movement range capabilities for the six possible degrees of freedom given in Table 14.5.6.9.2-1 shall be added to the maximum movement and rotations calculated for the entire range of seals in the MBJS determined using the appropriate strength load combination specified in Table 3.4.1-1.

C14.5.6.9.2

The MBJS should be designed and detailed to minimize excessive noise or vibration during the passage of traffic.

A common problem with MBJS is that the seals fill with debris. Traffic passing over the joint can work the seal from its anchorage by compacting this debris. MBJS systems can eject most of this debris in the traffic lanes if the seals are opened to near their maximum opening. Therefore, it is prudent to provide for additional movement capacity.

MBJS should permit movements in all six degrees of freedom, i.e., translations in all three directions and rotations about all three axes. While it is mandatory to provide at least 1.0 in. movement in the longitudinal direction, as shown in Table 14.5.6.9.2-1, no more than 2.0 in. should be provided in addition to the maximum calculated movement if feasible. Also, more than 1.0 in. should not be added if it causes a further seal to be used. In the five degrees of freedom other than the longitudinal direction, the MBJS should provide the maximum calculated movement in conjunction with providing for at least the minimum additional movement ranges shown in Table 14.5.6.9.2-1. Half of the movement range shall be assumed to occur in each direction about the mean position. Some bridges may require greater than the additional specified minimum values.

The designer should consider showing the total estimated transverse and vertical movement in each direction, as well as the rotation in each direction about the three principal axes on the contract plans. Vertical movement due to vertical grade, with horizontal bearings, and vertical movement due to girder end rotation may also be considered.

Further design guidelines and recommendations can be found in Chapter 19 of the *AASHTO LRFD Bridge Construction Specifications* and Dexter et al. (1997).

Table 14.5.6.9.2-1—Additional Minimum Movement Range Capability for MBJS

Type of Movement	Minimum Design Movement Range*
Longitudinal Displacement	Estimated Movement + 1.0 in.
Transverse Movement	1.0 in.
Vertical Movement	1.0 in.
Rotation around Longitudinal Axis	1°
Rotation Around Transverse Axis	1°
Rotation Around Vertical Axis	0.5°

* Total movement ranges presented in the table are twice the plus or minus movement.

14.5.6.9.3—Testing and Calculation Requirements

MBJS shall satisfy all test specifications detailed in Appendix A of the *AASHTO LRFD Bridge Construction Specifications*.

Each configuration of MBJS shall be designed for the strength and fatigue, and fracture limit states as specified in Articles 14.5.6.9.6 and 14.5.6.9.7.

14.5.6.9.4—Loads and Load Factors

Edgebeams, anchors, centerbeams, support bars, connections between centerbeams and support bars, support boxes, and connections, if any, to elements of the structure, such as girders, truss chords, crossbeams, etc., and other structural components shall be designed for the strength and fatigue and fracture limit states for the simultaneous application of vertical and horizontal axle loads. The edgebeams and anchors of MBJS in snow regions shall also be designed for the strength limit state for the snowplow load defined in Article 14.5.1.2. The design lane load need not be considered for MBJS.

The two wheel loads from each axle shall be centered 72.0 in. apart transversely. Each wheel load shall be distributed to the various edgebeams and centerbeams as specified in Article 14.5.6.9.5. The fraction of the wheel loads applied to each member shall be line loads applied at the center of the top surface of a member with a width of 20.0 in.

For the strength limit state, the vertical wheel loads shall be from the design tandem specified in Article 3.6.1.2.3; the wheel loads from the design truck in Article 3.6.1.2.2 need not be considered for the strength limit state of MBJS. Both of the tandem axles shall be considered in the design if the joint opening exceeds 4.0 ft. The vertical wheel load shall be increased by the dynamic load allowance specified for deck joints in Table 3.6.2.1-1.

The horizontal load for the strength limit state shall be 20 percent of the vertical wheel load ($LL + IM$), applied along the same line at the top surface of the centerbeam or edgebeam. For MBJS installed on vertical grades in excess of five percent, the additional horizontal component due to grade shall be added to the horizontal wheel load.

To investigate the strength limit state, the axles shall be oriented and positioned transversely to maximize the force effect under consideration.

The vertical wheel load ranges for the fatigue limit state shall be from the largest axle load from the three-axle design truck specified in Article 3.6.1.2.2. For fatigue limit state design of MBJS, this axle load shall be considered as the total load on a tandem, i.e., the total load shall be split into two axle loads spaced 4.0 ft apart. Both of these tandem axles shall be considered in the design if the joint opening exceeds 4.0 ft. The vertical load range shall be increased by the dynamic load allowance specified for deck joints in Table 3.6.2.1-1. The load factors to consider shall be as specified in Table 3.4.1-1 for the Fatigue I case.

C14.5.6.9.4

The vertical axle load for fatigue limit state design is one-half the 32.0-kip axle load of the design truck specified in Article 3.6.1.2.2 or 16.0 kips. This reduction recognizes that the main axles of the design truck are a simplification of actual tandem axles. The simplification is not satisfactory for MBJS and other expansion joints because expansion joints experience a separate stress cycle for each individual axle.

For strength limit state design, there are two load combinations that could be considered. However, recognizing that each main axle of the design truck should actually be treated as 32.0-kip tandems, it is clear the 50.0-kip design tandem, which is not used for fatigue limit state design, will govern for strength limit state design.

The loads specified for fatigue limit state design actually represent load ranges. When these loads are applied to a structural analysis model with no dead load applied to the model, the moment, force, or stress that is computed everywhere represents a moment, force or stress range. In service, these stress ranges are partly due to the downward load and partly due to upward rebound from the dynamic impact effect.

The dynamic load allowance (impact factor) specified for deck joints of 75 percent was developed from field testing of MBJS conducted in Europe and was confirmed in field tests described in Dexter et al. (1997). The stress range due to the load plus this dynamic load allowance represents the sum of the downward part of that stress range and the upward part of the stress range due to rebound. Measurements, described in Dexter et al. (1997), showed that the maximum downward amplification of the static load is 32 percent, with about 31 percent rebound in the upward direction.

The vertical axle load range with impact for fatigue limit state design is one-half of the largest axle load of the design truck specified in Article 3.6.1.2.2, multiplied by 1.75 to include the dynamic load allowance, multiplied by a load factor of 1.5 (or 2.0×0.75), as specified in Table 3.4.1-1 for the Fatigue I case, or 42.0 kips. The 0.75 load factor transforms axles of an HS20 truck to those of an HS15 fatigue truck, which is presumed to represent the effective stress range. The factor 2.0 amplifies the effective stress range for the fatigue limit state to the presumed maximum expected stress range which with impact is required to be less than the fatigue threshold in Article 14.5.6.9.7a. It is the intent of the fatigue design specifications that the static load without impact considered (24.0 kips or 42.0 kips/1.75) should be infrequently exceeded, see Dexter et al. (1997).

The horizontal load ranges for the fatigue limit state shall be at least 20 percent of the vertical wheel load range ($LL + IM$) for fatigue. For MBJS installed on vertical grades in excess of five percent, the additional horizontal component due to grade shall be added to the horizontal wheel load range.

To investigate the fatigue limit state, the axles shall be oriented perpendicular to the travel direction only, but shall be positioned transversely to maximize the force effect under consideration. In bridges with a skew greater than 14 degrees, the two wheel loads from an axle may not be positioned on a centerbeam simultaneously, and the maximum stress ranges at a critical detail on the centerbeam may be the difference between the stresses due to the application of each wheel load separately.

Field measurements were taken at a variety of locations; so typical truck excitations should be reflected in the dynamic load allowance. However, a joint located on a structure with significant settlement or deterioration of the approach roadway may be exposed to a dynamic load allowance 20 percent greater due to dynamic excitation of the trucks.

MBJS with centerbeam spans less than 4.0 ft are reported to have lower dynamic effects (Pattis, 1993; Tschemmernegg and Pattis, 1994). The fatigue limit state design provisions of Article 14.5.6.9.7 happen to also limit the spans of typical 5.0 in. deep centerbeams to around 4.0 ft anyway, so there is no need for a specific limitation of the span.

At sites with a tight horizontal curve (less than 490-ft radius) the vertical moments could be about 20 percent higher than would be expected. An increase in the dynamic load allowance for cases where there is a tight horizontal curve is not considered necessary if the speed of trucks on these curves is limited. In this case, the dynamic impact will be less than for trucks at full speed and the decreased dynamic impact will approximately offset the increased vertical load due to the horizontal curve.

The dynamic load allowance is very conservative when applied to the vertical load for strength limit state design, since in strength limit state design peak loads, not load ranges, are of interest. In the measurements made on MBJS in the field, the maximum downward vertical moment was only 1.32 times the static moment. There are usually no consequences of this conservative simplification since the proportions of the members are typically governed by fatigue and not strength.

The horizontal loads are taken as 20 percent of the vertical load plus the dynamic load allowance. In-service measurements, described in Dexter et al. (1997), indicate that the 20 percent horizontal load range is the largest expected from traffic at steady speeds, including the effect of acceleration and routine braking. The 20 percent horizontal load range for fatigue limit state design represents ten percent forward and ten percent backward.

Where strength limit state design is considered, the 20 percent horizontal load requirement corresponds to a peak load of 20 percent applied in one direction. The 20 percent horizontal peak load is appropriate for strength limit state design. However, the field measurements, described in Dexter et al. (1997), show that the horizontal force effects resulting from extreme braking can be much greater than at steady speeds. Therefore, the 20 percent peak horizontal load represents the extreme braking for strength limit state design. For fatigue limit state design, these extreme events occur so infrequently that they do not usually need to be taken into account in most cases.

14.5.6.9.5—Distribution of Wheel Loads

Each edgebeam shall be designed for 50 percent of the vertical and horizontal wheel loads specified in Article 14.5.6.9.4.

Table 14.5.6.9.5-1 specifies the centerbeam distribution factor, i.e., the percentage of the design vertical and horizontal wheel loads specified in Article 14.5.6.9.4 that shall be applied to an individual centerbeam for the design of that centerbeam and associated support bars. Distribution factors shall be interpolated for centerbeam top flange widths not given in the table, but in no case shall the distribution factor be taken as less than 50 percent. The remainder of the load shall be divided equally and applied to the two adjacent centerbeams or edgebeams.

Table—14.5.6.9.5-1 Centerbeam Distribution Factors

Width of Centerbeam Top Flange	Distribution Factor
2.5 in. (or less)	50%
3.0 in.	60%
4.0 in.	70%
4.75 in.	80%

Special consideration should be given to the horizontal forces if the MBS is located near a traffic light, stop sign, or toll facility or if the centerbeam is unusually wide.

C14.5.6.9.5

For the convenience of the designer, the vertical axle load range with impact for fatigue limit state design on one centerbeam 2.5 in. or less in width is 21.0 kips. On the centerbeam, each fraction of the wheel load of 10.5 kips is spaced 72.0 in. apart distributed over a width of 20.0 in. with a magnitude of 0.525 kips/in.

The distribution factor, i.e., the fraction of the design wheel load range assigned to a single centerbeam, is a function of applied load, tire pressure, gap width, and centerbeam height mismatch. Unfortunately, many of the factors affecting the distribution factor are difficult to quantify individually and even more difficult to incorporate in an equation or graph. Existing methods to estimate the distribution factor do not incorporate all of these variables and consequently can be susceptible to error when used outside the originally intended range. In view of this uncertainty, a simplified tabular method is used to estimate the distribution factor. Alternative methods are permitted if they are based on documented test data.

Wheel load distribution factors shown in Table 14.5.6.9.5-1 are based on field and laboratory testing, described in Dexter et al. (1997), and were found to be in acceptable agreement with the findings of other researchers. These distribution factors are based on the worst-case assumption of maximum joint opening (maximum gap width). Calculating the stress ranges at maximum gap opening is approximately 21 percent too conservative for fatigue limit state design. However, as explained in Dexter et al. (1997), this conservatism compensates for a lack of conservatism in the AASHTO fatigue design truck axle load.

For comparison to the fatigue threshold, the factored static axle load range, without the dynamic load allowance, would be 24.0 kips (or 42.0 kips/1.75, as discussed in Article C14.5.6.9.4). The static axle load range at the fatigue limit state is supposed to represent an axle load that is rarely exceeded. However, the fatigue limit state design load is multiplied by a distribution factor that is 21 percent too large, so in effect, this is equivalent to a static axle load range at the fatigue limit state of 29.0 kips that should be rarely exceeded, if correct distribution factors were used. This is more consistent with the statistics of weigh-in-motion data where axle loads with exceedence levels of 0.01 percent were up to 36.0 kips, see Schilling (1990) or Nowak and Laman (1995).

A mitigating factor on the impact of these larger axle loads is that the distribution factor decreases with increasing axle load. Because of this effect, measurements reported in Dexter et al. (1997) show that as the axle load is increased from 24.0 to 36.0 kips, an increase of 50 percent, the load on one centerbeam increases from 12.6 to only 14.6 kips, an increase of only 16 percent.

Even though maximum gap opening occurs only rarely, it is an appropriate assumption for checking the Strength-I limit state. No additional conservatism is warranted in this case, however, because the dynamic load allowance is about 32 percent too conservative for strength limit state design only, as discussed in Article C14.5.6.9.

Another advantage of using the conservative distribution factors is that it may compensate for ignoring the effect of potential centerbeam height mismatch. Laboratory studies show that a height mismatch of 0.125 in. resulted in a 24 percent increase in the measured distribution factor, see Dexter et al. (1997). Although such mismatch is not common presently, and recent construction specifications are supposed to preclude this mismatch, it is prudent to anticipate that it may occur.

14.5.6.9.6—Strength Limit State Design Requirements

Where the MBS is analyzed for the strength limit state, the gap between centerbeams shall be assumed to be at the fully opened position, typically 3.0 in.

The MBS shall be designed to withstand the force effects for the strength limit state specified in Article 6.5.4 by applying the provisions of Articles 6.12 and 6.13, as applicable. All sections shall be compact, satisfying the provisions of Articles A6.1, A6.2, A6.3.2, and A6.3.3. MBS shall be designed to withstand the load combination for the Strength I limit state that is specified in Table 3.4.1-1 for the simultaneous application of vertical and horizontal axle loads specified in Article 14.5.6.9.4. Dead loads need not be included. Loads shall be distributed as specified in Article 14.5.6.9.5.

Anchors shall be investigated at the strength limit state due to vertical wheel loads without the horizontal wheel loads using the requirements of Article 6.10.10.4.3. The anchors shall be checked separately for the horizontal wheel loads at the strength limit state. In snow regions, another separate analysis shall be performed for the anchors for the snowplow load defined in Article 14.5.1.2. Pullout or breakout at the strength limit state under each of these loads shall be investigated by the latest ACI 318 (*Building Code Requirements for Structural Concrete*), using the following resistance factors:

- For anchors governed by the steel, the resistance factors are:

$$\phi_{tension} = 0.80$$

$$\phi_{shear} = 0.75$$

- For anchors governed by the concrete, the load factors for Condition A, supplemental reinforcement in the failure area, are:

$$\phi_{A\ tension} = 0.85$$

$$\phi_{A\ shear} = 0.85$$

- For anchors governed by the concrete, the load factors for Condition B, no supplemental reinforcement, are:

C14.5.6.9.6

Anchorage calculations for strength and fatigue limit states are presented in Dexter et al. (2002). A prescriptive design was found that satisfies the strength and fatigue limit state requirements presented in this specification, including the snowplow load. This design may be adopted without presenting explicit calculations. This design consists of a steel edgebeam minimum thickness 0.375 in. with Grade 50 (50.0 ksi yield) 0.5 in. diameter welded headed anchors (studs) with length of anchor of 6.0 in. spaced every 12.0 in. The welded headed anchor shall have minimum cover depth of 3.0 in., except where over the support boxes, where the cover depth is 2.0 in.

Analyzing the centerbeam as a continuous beam over rigid supports has been found to give good agreement with measured strains for loads in the vertical direction. For loads in the horizontal direction, the continuous beam model is conservative. For the loads in the horizontal direction, more accurate results can be achieved by treating the centerbeams and support bars as a coplanar frame pinned at the ends of the support bars.

Maximum centerbeam stresses in interior spans are typically generated with one of the wheel loads centered in the span. However, if the span lengths are the same, the exterior spans (first from the curb) will typically govern the design. In an optimum design, this exterior span should be about ten percent less than typical interior spans.

The vertical and horizontal wheel loads are idealized as line loads along the centerlines of the centerbeams, i.e., it is not necessary to take into account eccentricity of the forces on the centerbeam. The maximum reaction of the centerbeam against the support bar is generated when the wheel load is centered over the support bar. This situation may govern for the throat of the centerbeam/support bar weld, for design of the stirrup of a single-support-bar system, or for design of the support bar.

MBS installed on skewed structures may require special attention in the design process.

$$\phi_{B \text{ tension}} = 0.75$$

$$\phi_{B \text{ shear}} = 0.75$$

14.5.6.9.7—Fatigue Limit State Design Requirements

14.5.6.9.7a—General

MBJS structural members, including centerbeams, support bars, connections, bolted and welded splices, and attachments, shall meet the fracture toughness requirements in Article 6.6.2. Bolts subject to tensile fatigue shall satisfy the provisions of Article 6.13.2.10.3.

MBJS structural members, including centerbeams, support bars, connections, bolted and welded splices, and attachments, shall be designed for the fatigue limit state as specified in Article 6.6.1.2 and as modified and supplemented herein.

Each detail shall satisfy:

$$\Delta f \leq (\Delta F)_{TH} \quad (14.5.6.9.7a-1)$$

where:

Δf = force effect, design live load stress range due to the simultaneous application of vertical and horizontal axle loads specified in Article 14.5.6.9.4 and distributed as specified in Article 14.5.6.9.5, and calculated as specified in Article 14.5.6.9.7b (ksi)

ΔF_{TH} = constant amplitude fatigue threshold taken from Table 6.6.1.2.5-3 for the detail category of interest (ksi)

The fatigue detail categories for the centerbeam-to-support-bar connection, shop splice, field splice, or other critical details shall be established by the fatigue testing as required by Article 14.5.6.9.3. All other details shall have been included in the test specimen. Details that did not crack during the fatigue test shall be considered noncritical. The fatigue detail categories for noncritical details shall be determined using Table 6.6.1.2.3-1.

Anchors and edgebeams shall be investigated for the fatigue limit state considering the force effects from vertical and horizontal wheel loads. Shear connectors and other anchors shall be designed for the fatigue limit state to resist the vertical wheel loads according to the provisions of Article 6.10.10.2 for the Fatigue I case defined in Article 3.4.1. The force effects from the horizontal wheel loads need not be investigated for standard welded headed anchors.

Edgebeams shall be at least 0.375 in. thick. Edgebeams with standard welded headed anchors spaced at most every 12.0 in. need not be investigated for in-plane bending for the fatigue limit state.

C14.5.6.9.7a

The fatigue limit state strength of particular details in aluminum are approximately one-third the fatigue limit state strength of the same details in steel and, therefore, aluminum is typically not used in MBJS.

Yield strength and fracture toughness and weld quality have not been noted as particular problems for MBJS.

The design of the MBJS will typically be governed by the stress range at fatigue limit state critical details. The static strength limit state must also be checked according to the requirements of Article 14.5.6.9.6, but will typically not govern the design unless the total opening range and the support bar span is very large. Alternate design methods and criteria may be used if such methods can be shown through testing and/or analysis to yield fatigue-resistant and safe designs. The target reliability level for the fatigue limit state is 97.5 percent probability of no fatigue cracks over the lifetime of the MBJS.

Provisions are not included for a finite life fatigue limit state design (Fatigue II case, as defined in Article 3.4.1). Typically, most structures that require a modular expansion joint carry enough truck traffic to justify an infinite-life fatigue limit state design approach (Fatigue I case, as defined in Article 3.4.1). Furthermore, uncertainty regarding the number of axles per truck and the number of fatigue cycles per axle would make a finite life design approach difficult, and little cost is added to the MBJS by designing for infinite fatigue life.

The intent of this procedure is to assure that the stress range from the fatigue limit state load range is less than the CAFL and thereby ensuring essentially an infinite fatigue life.

Fatigue-critical MBJS details include:

- The connection between the centerbeams and the support bars;
- Connection of any attachments to the centerbeams (e.g., horizontal stabilizers or outriggers); and
- Shop and/or field splices in the centerbeams.

MBJS details can in many cases be clearly associated with analogous details in the bridge design specifications. In other cases, the association is not clear and must be demonstrated through full-scale fatigue testing.

The detail of primary concern is the connection between the centerbeams and the support bars. A typical full-penetration welded connection, which was shown previously, can be associated with Category C. Fillet welded connections have very poor fatigue resistance and should not be allowed.

Bolted connections should be classified as a Category D detail, with respect to the bending stress range in the centerbeam. As in any construction, more than one bolt must be used in bolted connections.

The bolted connections in single-support-bar MBS usually involve a yoke or stirrup through which the support bar slides and/or swivels. Field-welded splices of the centerbeams and edgebeams are also prone to fatigue. In new construction, it may be possible to make a full-penetration welded splice in the field before the joint is lowered into the blockout. However, in reconstruction work, the joint is often installed in several sections at a time to maintain traffic. In these cases, the splice must be made after the joint is installed. Because of the difficulty in access and position, obtaining a full-penetration butt weld in the field after the joint is installed may be impossible, especially if there is more than one centerbeam. Partial-penetration splice joints have inherently poor fatigue resistance and should not be allowed.

Bolted splices have been used and no cracking of these bolted splice details has been reported. The bolted splice plates behave like a hinge, i.e., they do not take bending moments. As a result, such details are subjected only to small shear stress ranges and need not be explicitly designed for the fatigue limit state. However, the hinge in the span creates greater bending moments at the support bar connection, therefore, the span with the field splice must be much smaller than the typical spans to reduce the applied stress ranges at the support bar connection.

Thin stainless-steel slider plates are often welded like cover plates on the support bars. The fatigue strength of the ends of cover plates is Category E. However, there have not been any reports of fatigue cracks at these slider plate details in MBS. The lack of problems may be because the support bar bending stress range is much lower at the location of the slider plate ends than at the centerbeam connection, which is the detail that typically governs the fatigue limit state design of the support bar. Also, it is possible that the fatigue strength is greater than that of conventional cover plates, perhaps because of the thinness of the slider plate.

The fatigue limit state of the support bars or centerbeams should also be checked at the location of welded attachments to react against the horizontal equidistant devices. In addition to checking the equidistant device attachments with respect to the stress range in the support bar, there is also some bending load in the attachment itself. The equidistant devices take part of the horizontal load, especially in single-support bar systems. The horizontal load is also transferred through friction in the bearings and springs of the centerbeam connection. However, since this transfer is influenced by the dynamic behavior of the MBS, it is very difficult to quantify the load in the attachments.

These attachments are thoroughly tested in the Opening Movement Vibration Test required in Article 14.5.6.9.3. If the equidistant device attachments have no reported problems in the Opening Movement Vibration Test, they need not be explicitly designed as a loaded attachment for the fatigue limit state. If there were a

14.5.6.9.7b—Design Stress Range

The design stress ranges, Δf , at all fatigue critical details shall be obtained from structural analyses of the modular joint system due to the simultaneous application of vertical and horizontal axle loads specified in Article 14.5.6.9.4 and distributed as specified in Article 14.5.6.9.5. The MBJS shall be analyzed with a gap opening no smaller than the midrange configuration and no smaller than half of maximum gap opening. For each detail, the structural analysis shall include the worst-case position of the axle load to maximize the design stress range at that particular detail.

The nominal stress ranges, Δf , shall be calculated as follows for specific types of MBJS:

- Single-Support-Bar Systems
 - Centerbeam: The design bending stress range, Δf , in the centerbeam at a critical section adjacent to a welded or bolted stirrup shall be the sum of the stress ranges in the centerbeam resulting from horizontal and vertical bending at the critical section. The effects of stresses in any load-bearing attachments, such as the stirrup or yoke, need not be considered when calculating the stress range in the centerbeam. For bolted single-support-bar systems, stress ranges shall be calculated on the net section.
 - Stirrup: The design stress range, Δf , in the stirrup or yoke shall consider the force effects of the vertical reaction force range between the centerbeam and support bar. The stress range shall be calculated by assuming a load range in the stirrup that is greater than or equal to 30 percent of the total vertical reaction force range. The calculation of the design stress range in the stirrup or yoke need not consider the effects of stresses in the centerbeam. The effects of horizontal loads may be neglected in the fatigue limit state design of the stirrup.
- Welded Multiple-Support-Bar Systems
 - Centerbeam Weld Toe Cracking, i.e., Type A Cracking: The design stress range, Δf , for Type A cracking shall include the concurrent effects of vertical and horizontal bending stress ranges in the centerbeam, S_{RB} , and the vertical stress ranges in the top of the weld, S_{RZ} , as shown in Figure 14.5.6.9.7b-1. The design stress range for Type A cracking shall be determined as:

fatigue problem with these attachments, it would be discovered in the Opening Movement Vibration Test.

C14.5.6.9.7b

Since the design axle load and distribution factors represent a “worst case”, the structural analysis for fatigue limit state design need not represent conditions worse than average. Therefore, for fatigue loading, the assumed gap can be equal to or greater than the midrange of the gap, typically 1.5 in., which is probably close to the mean or average opening. The gap primarily affects the support bar span.

See Article C14.5.6.9.6 for guidelines on the structural analysis. MBJS installed on skewed structures may require special attention in the design process.

On structures with joint skews greater than 14 degrees, it can be shown that the wheels at either end of an axle will not roll over a particular centerbeam simultaneously. This asymmetric loading could significantly affect the stress range at fatigue sensitive details, either favorably or adversely. Nevertheless, a skewed centerbeam span is subjected to a range of moments that includes the negative moment from the wheel in the adjoining span, followed or preceded by the positive moment from the wheel in the span.

The stress states at the potential crack locations in these connections are multiaxial and very complicated. Simplified assumptions are used to derive the design stress range at the details of interest for common types of MBJS. Experience has shown that these simplified assumptions are sufficient provided that the same assumptions are applied in calculating the applied stress range for plotting the fatigue test data from which the design detail category was determined.

The design stress range should be estimated at a critical section at the weld toe. For example, Figure C14.5.6.9.7b-1 shows a typical moment diagram for the support bar showing the critical section. The support bar design bending stress range is a result of the sum of the bending moment created by the applied centerbeam reaction and the additional overturning moment developed by the horizontal force applied at the top of the centerbeam.

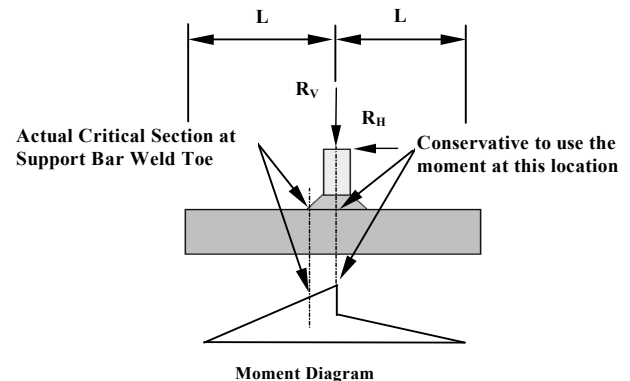

Figure C14.5.6.9.7b-1—Typical Moment Diagram for a Support Bar

$$\Delta f = \sqrt{S_{RB}^2 + S_{RZ}^2} \quad (14.5.6.9.7b-1)$$

in which:

$$S_{RB} = \frac{M_V}{S_{xcb}} + \frac{M_H}{S_{ycb}} \quad (14.5.6.9.7b-2)$$

$$S_{RZ} = \frac{M_{OT}}{S_{Wtop}} + \frac{R_V}{A_{Wtop}} \quad (14.5.6.9.7b-3)$$

$$M_{OT} = R_H d_{cb} \quad (14.5.6.9.7b-4)$$

where:

S_{RB} = combined bending stress range in the centerbeam (ksi)

M_V = vertical bending moment range in the centerbeam on the critical section located at the weld toe due to the vertical force range (kip-in.)

M_H = horizontal bending moment range in the centerbeam on the critical section located at the weld toe due to horizontal force range (kip-in.)

M_{OT} = overturning moment range from horizontal reaction force (kip-in.)

S_{xcb} = vertical section modulus to the bottom of the centerbeam (in.³)

S_{ycb} = horizontal section modulus of the centerbeam (in.³)

S_{RZ} = vertical stress range in the top of the centerbeam-to-support-bar weld from the concurrent reaction of the support beam (ksi)

R_V = vertical reaction force range in the connection (kip)

R_H = horizontal reaction force range in the connection (kip)

d_{cb} = depth of the centerbeam (in.)

S_{Wtop} = section modulus of the weld at the top for bending in the direction normal to the centerbeam axis (in.³)

A_{Wtop} = area of weld at the top (in.²)

It is conservative to estimate the moments at the centerline of the centerbeam as shown.

For all details except the welded-multiple-support-bar centerbeam to support bar connection, the design stress range can be calculated using the design moment at the location of interest. Special equations for calculating the stress range are provided for welded multiple-support-bar MBS. These special equations are based on cracking that has been observed in fatigue tests of welded multiple-support-bar MBS. For the case of welded multiple-support bar centerbeam to support bar connections, the design stress range is obtained by taking the square root of the sum of the squares of the horizontal stress ranges in the centerbeam or support bar and vertical stress ranges in the weld. Note this method of combining the stresses ignores the contribution of shear stresses in the region. Shear stresses are ignored in this procedure since they are typically small and very difficult to determine accurately. More details are provided in Dexter et al. (1997).

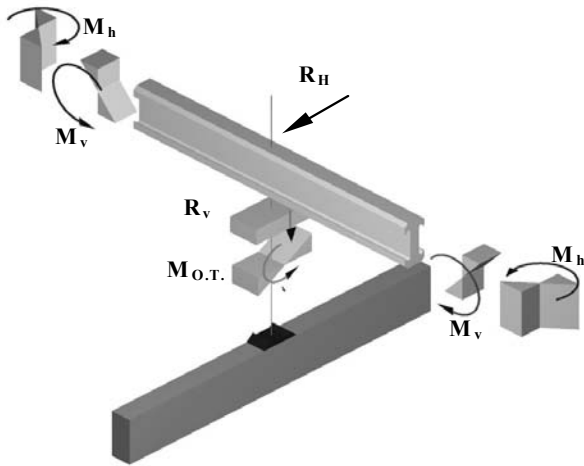

Figure 14.5.6.9.7b-1—Force Effects Associated with Type A Cracking

- Support Bar Weld Toe Cracking, i.e., Type B Cracking: The design stress range, Δf , for Type B cracking shall include the concurrent effects of vertical bending stress ranges in the support bar, S_{RB} , and the vertical stress ranges in bottom of the weld, S_{RZ} , as shown in Figure 14.5.6.9.7b-2. The design stress range, Δf , for Type B cracking shall be determined as:

$$\Delta f = \sqrt{S_{RB}^2 + S_{RZ}^2} \quad (14.5.6.9.7b-5)$$

in which:

$$S_{RB} = \frac{M_V}{S_{Xsb}} + \frac{1}{2} \frac{R_H \left(d_{cb} + h_w + \frac{1}{2} d_{sb} \right)}{S_{Xsb}} \quad (14.5.6.9.7b-6)$$

$$S_{RZ} = \frac{R_H (d_{cb} + h_w)}{S_{Wbot}} + \frac{R_V}{A_{Wbot}} \quad (14.5.6.9.7b-7)$$

where:

S_{RB} = bending stress range in the support bar due to maximum moment including moment from vertical reaction and overturning at the connection (ksi)

M_V = component of vertical bending moment range in the support bar due to the vertical reaction force range in the connection located on the critical section at the weld toe (kip-in.)

S_{Xsb} = vertical section modulus of the support bar to the top of the support bar (in.³)

h_w = height of the weld (in.)

d_{sb} = depth of the support bar (in.)

S_{RZ} = vertical stress range in the bottom of the centerbeam-to-support-bar weld from the vertical and horizontal reaction force ranges in the connection (ksi)

S_{Wbot} = section modulus of the weld at the bottom for bending in the direction of the support bar axis (in.³)

A_{Wbot} = area of weld at the bottom (in.²)

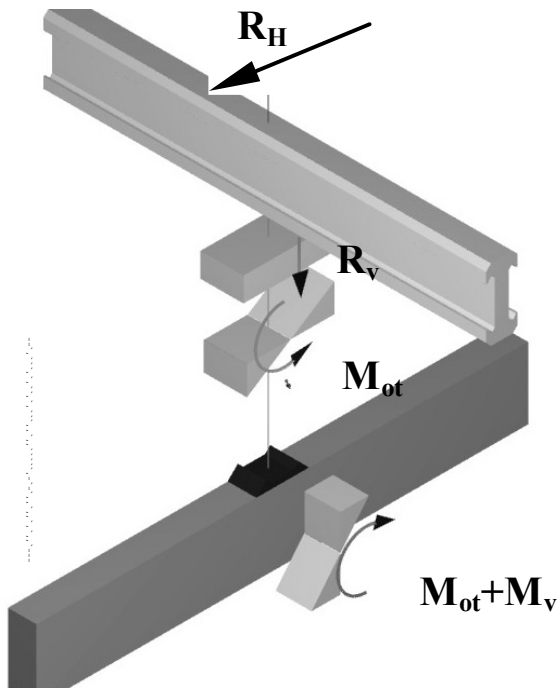

Figure 14.5.6.9.7b-2—Force Effects Associated with Type B Cracking

- Cracking Through the Throat of the Weld, i.e., Type C Cracking: The design stress range, Δf , for Type C cracking is the vertical stress, range, S_{RZ} , at the most narrow cross-section of the centerbeam-to-support-bar weld from the vertical and horizontal reaction force ranges in the connection, as shown in Figure 14.5.6.9.7b-3. The design stress range, Δf , for Type C cracking shall be determined as:

$$\Delta f = \frac{R_V}{A_{Wmid}} + \frac{R_H \left(d_{cb} + \frac{1}{2} h_w \right)}{S_{Wmid}} \quad (14.5.6.9.7b-8)$$

where:

S_{Wmid} = section modulus of the weld at the most narrow cross-section for bending in the direction normal to the centerbeam axis (in.³)

A_{Wmid} = minimum cross-sectional area of weld (in.²)

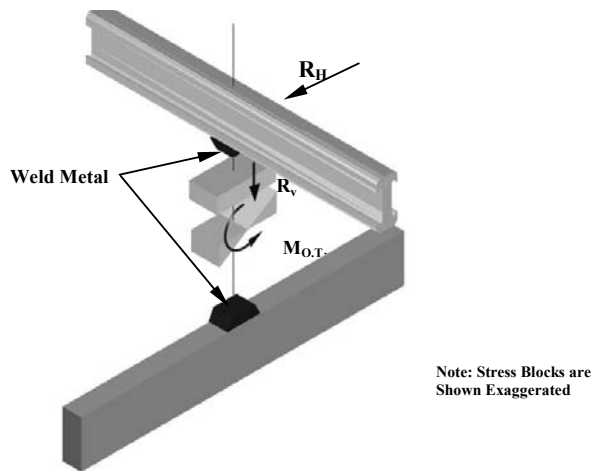

Figure 14.5.6.9.7b-3—Force Effects Associated with Type C Cracking

14.6—REQUIREMENTS FOR BEARINGS

14.6.1—General

Bearings may be fixed or movable as required for the bridge design. Movable bearings may include guides to control the direction of translation. Fixed and guided bearings shall be designed to resist all appropriate loads and restrain unwanted translation.

Unless otherwise noted, the resistance factor for bearings, ϕ , shall be taken as 1.0.

Bearings subject to net uplift at any limit state shall be secured by tie-downs or anchorages.

The magnitude and direction of movements and the loads to be used in the design of the bearing shall be clearly defined in the contract documents.

Combinations of different types of fixed or movable bearings should not be used at the same expansion joint, bent, or pier, unless the effects of differing deflection and rotation characteristics on the bearings and the structure are accounted for in the design.

Multirotational bearings conforming to the provisions of this Section should not be used where vertical loads are less than 20 percent of the vertical bearing capacity.

All bearings shall be evaluated for component and connection strength and bearing stability.

Where two bearings are used at a support of box girders, the vertical reactions should be computed with consideration of torque resisted by the pair of bearings.

C14.6.1

Bearings support relatively large loads while accommodating large translation or rotations.

The behavior of bearings is quite variable, and there is very little experimental evidence to precisely define ϕ for each limit state. ϕ is taken to be equal to 1.0 in many parts of Article 14.6 where a more refined estimate is not warranted. The resistance factors are often embedded in the design equations and based on judgment and experience, but they are generally thought to be conservative.

Differing deflection and rotational characteristics may result in damage to the bearings and/or structure.

Bearings loaded to less than 20 percent of their vertical capacity require special design (FHWA, 1991).

Bearings can provide a certain degree of horizontal load resistance by limiting the radius of the spherical surface. However, the ability to resist horizontal loads is a function of the vertical reaction on the bearing, which could drop during earthquakes or other extreme event loadings. In general, bearings are not recommended for horizontal to vertical load ratios of over 40 percent unless the bearings are intended to act as fuses or irreparable damage is permitted.

14.6.2—Characteristics

The bearing chosen for a particular application shall have appropriate load and movement capabilities. Table 14.6.2-1 and Figure 14.6.2-1 may be used as a guide when comparing the different bearing systems.

The following terminology shall apply to Table 14.6.2-1:

S	=	Suitable
U	=	Unsuitable
L	=	Suitable for limited applications
R	=	May be suitable, but requires special considerations or additional elements such as sliders or guideways
Long.	=	Longitudinal axis
Trans.	=	Transverse axis
Vert.	=	Vertical axis

C14.6.2

Practical bearings will often combine more than one function to achieve the desired results. For example, a pot bearing may be combined with a PTFE sliding surface to permit translation and rotation.

Information in Table 14.6.2-1 is based on general judgment and observation, and there will obviously be some exceptions. Bearings listed as suitable for a specific application are likely to be suitable with little or no effort on the part of the Engineer other than good design and detailing practice. Bearings listed as unsuitable are likely to be marginal, even if the Engineer makes extraordinary efforts to make the bearing work properly. Bearings listed as suitable for limited application may work if the load and rotation requirements are not excessive.

Table 14.6.2-1—Bearing Suitability

Type of Bearing	Movement		Rotation about Bridge Axis Indicated			Resistance to Loads		
	Long.	Trans.	Long.	Trans.	Vert.	Long.	Trans.	Vert.
Plain Elastomeric Pad	S	S	S	S	L	L	L	L
Fiberglass-Reinforced Pad	S	S	S	S	L	L	L	L
Cotton-Duck-Reinforced Pad	U	U	U	U	U	L	L	S
Steel-Reinforced Elastomeric Bearing	S	S	S	S	L	L	L	S
Plane Sliding Bearing	S	S	U	U	S	R	R	S
Curved Sliding Spherical Bearing	R	R	S	S	S	R	R	S
Curved Sliding Cylindrical Bearing	R	R	U	S	U	R	R	S
Disc Bearing	R	R	S	S	L	S	S	S
Double Cylindrical Bearing	R	R	S	S	U	R	R	S
Pot Bearing	R	R	S	S	L	S	S	S
Rocker Bearing	S	U	U	S	U	R	R	S
Knuckle Pinned Bearing	U	U	U	S	U	S	R	S
Single Roller Bearing	S	U	U	S	U	U	R	S
Multiple Roller Bearing	S	U	U	U	U	U	U	S

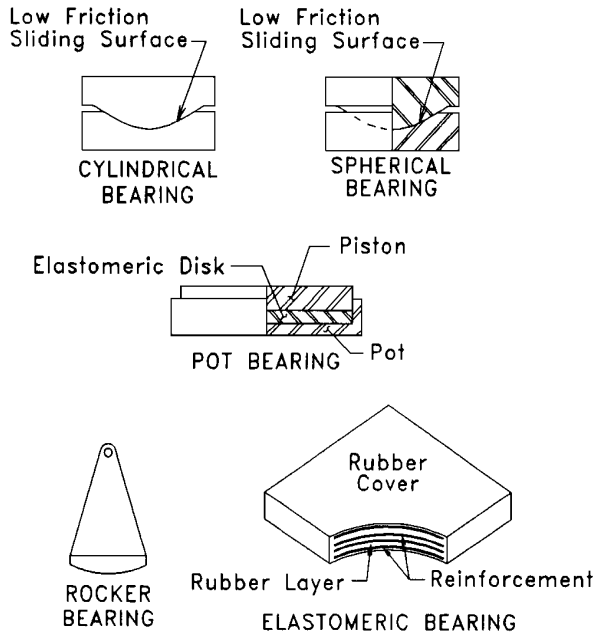

Figure 14.6.2-1—Common Bearing Types

14.6.3—Force Effects Resulting from Restraint of Movement at the Bearing

14.6.3.1—Horizontal Force and Movement

Horizontal forces and moments induced in the bridge by restraint of movement at the bearings shall be determined using the movements and bearing characteristics specified in Article 14.7. For bearings with elastomeric elements, these characteristics should include, but are not limited to, the consideration of increased shear modulus, G , at temperatures below 73°F.

Expansion bearings and their supports shall be designed in a manner such that the structure can undergo movements to accommodate the seismic and other extreme event displacement determined using the provisions in Section 3 without collapse. Adequate support length shall be provided for all bearings in accordance with Article 4.7.4.4.

The Engineer shall determine the number of bearings required to resist the loads specified in Section 3 with consideration of the potential for unequal participation due to tolerances, unintended misalignments, the capacity of the individual bearings, and the skew.

Consideration should be given to the use of field adjustable elements to provide near simultaneous engagement of the intended number of bearings.

C14.6.3.1

Restraint of movement results in a corresponding force or moment in the structure. These force effects should be calculated taking into account the stiffness of the bridge and the bearings. The latter should be estimated by the methods outlined in Article 14.7. In some cases, the bearing stiffness depends on time and temperature, as well as on the movement. For example, the designer should take note that in cold temperatures which approach the appropriate minimum specified zone temperatures, the shear modulus, G , of an elastomer may be as much as four times that at 73°F. See Article 14.7.5.2 and AASHTO M 251 for more information.

Expansion bearings should allow sufficient movement in their unrestrained direction to prevent premature failure due to seismic and other extreme event displacements.

Often, bearings do not resist load simultaneously, and damage to only some of the bearings at one end of a span is not uncommon. When this occurs, high load concentrations can result at the location of the undamaged bearings, which should be taken into account. The number of bearings engaged should be based on type, design, and detailing of the bearings used, and on the bridge skew. Skew angles under 15 degrees are usually ignored. Skew angles over 30 degrees are usually considered significant

At the strength and extreme event limit states, horizontal forces transmitted to the superstructure and substructure by bearings, H_{bu} , shall be taken as those induced by sliding friction, rolling friction, or shear deformation of a flexible element in the bearing.

Sliding friction force shall be taken as:

$$H_{bu} = \mu P_u \quad (14.6.3.1-1)$$

where:

H_{bu} = lateral load transmitted to the superstructure and substructure by bearings from applicable strength and extreme event load combinations in Table 3.4.1-1 (kip)

μ = coefficient of friction

P_u = compressive force from applicable strength and extreme event load combinations in Table 3.4.1-1 (kip)

The force due to the deformation of an elastomeric element shall be taken as:

$$H_{bu} = GA \frac{\Delta_u}{h_{rt}} \quad (14.6.3.1-2)$$

where:

G = shear modulus of the elastomer (ksi)

A = plan area of elastomeric element or bearing (in.²)

Δ_u = shear deformation from applicable strength and extreme event load combinations in Table 3.4.1-1 (in.)

h_{rt} = total elastomer thickness (in.)

Strength and extreme event limit states rolling forces shall be determined by testing.

14.6.3.2—Moment

At the strength and extreme event limit states, both the substructure and superstructure shall be designed for the largest moment, M_u , transferred by the bearing.

For curved sliding bearings without a companion flat sliding surface, M_u shall be taken as:

$$M_u = \mu P_u R \quad (14.6.3.2-1)$$

For curved sliding bearings with a companion flat sliding surface, M_u shall be taken as:

and need to be considered in analysis. Skewed bridges have a tendency to rotate under seismic loading, and bearings should be designed and detailed to accommodate this effect.

Horizontal forces transmitted to other bridge elements by bearings do not include forces associated with the deformations of stiff bearing elements or hard metal-on-metal contact of bearing components because provisions in Article 14.7 are intended to avoid such contact.

Maximum extreme event limit state forces should be considered when the bearing is not intended to act as a fuse or irreparable damage is not permitted.

Special consideration should be given to bearings that support large horizontal loads relative to the vertical load (SCEF, 1991).

Eq. 14.6.3.1-1 is a function of vertical forces and friction, and is a measure of the maximum horizontal force which could be transmitted to the superstructure or substructure before slip occurs. Eq. A13.3.2-2 is also a measure of the maximum transmitted horizontal force, but is dependant primarily upon the shear modulus (stiffness) of the elastomer and applied lateral forces such as braking.

C14.6.3.2

Maximum extreme event limit state forces should be considered when the bearing is not intended to act as a fuse or irreparable damage is not permitted.

The tangential force in curved sliding bearings is caused by friction resistance at the curved surface, and it acts about the center of the curved surface. M_u is the moment due to this force that is transmitted by the bearing. The moment imposed on individual components of the bridge structure may be different from M_u depending on the location of the axis of rotation and can be calculated by a rational method.

$$M_u = 2\mu P_u R \quad (14.6.3.2-2)$$

where:

M_u = moment transmitted to the superstructure and substructure by bearings from applicable strength and extreme event load combinations in Table 3.4.1-1 (kip-in.)

R = radius of curved sliding surface (in.)

For unconfined elastomeric bearings and pads, M_u shall be taken as:

$$M_u = 1.60(0.5E_c I) \frac{\theta_s}{h_{rt}} \quad (14.6.3.2-3)$$

where:

I = moment of inertia of plan shape of bearing (in.⁴)

E_c = effective modulus of elastomeric bearing in compression (ksi)

θ_s = maximum service limit state design rotation angle specified in Article 14.4.2.1 (rad.)

h_{rt} = total elastomer thickness (in.)

For CDP, M_u shall be taken as:

$$M_u = 1.25(4.5 - 2.2S + 0.6\sigma_s) \frac{E_c I}{t_p} \theta_s \quad (14.6.3.2-4)$$

where:

E_c = uniaxial compressive stiffness of the CDP bearing pad. It may be taken as 30 ksi in lieu of pad-specific test data (ksi)

t_p = total thickness of CDP pad (in.)

S = shape factor of the CDP pad computed based on Eq. 14.7.5.1-1 and based on total pad thickness

σ_s = average compressive stress due to total load associated with the maximum rotation from applicable service load combinations in Table 3.4.1-1 (ksi)

θ_s = maximum rotation of the CDP pad from applicable service load combinations in Table 3.4.1-1 (rad.)

The load-deflection curve of an elastomeric bearing is nonlinear, so E_c is load dependent. One acceptable approximation for the effective modulus is:

$$E_c = 4.8GS^2 \quad (C14.6.3.2-1)$$

where:

S = shape factor of an individual elastomer layer

G = shear modulus of the elastomer (ksi)

For a more precise approximation of effective modulus, the denominator of Eq. 14.7.5.3.3-15 may be used along with a calculated B_a from Eq. C14.7.5.3.3-7 or Eq. C14.7.5.3.3-8.

The factor 1.60 in Eq. 14.6.3.2-3 is an average multiplier on total load on the bearing to estimate a strength limit state load, M_u , based on a service limit state rotation, θ_s .

The factor 1.25 in Eq. 14.6.3.2-4 is a multiplier on total load on the bearing to estimate a strength limit state load, M_u , based on a service limit state rotation, θ_s , and stress, σ_s .

The rotational stiffness, K , of CDP is provided by:

$$K = (4.5 - 2.2S + 0.6\sigma_s) \frac{E_c I}{t_p} \quad (C14.6.3.2-2)$$

The moment, M_u , may be crucial for the design of CDP, because movable CDP are normally designed with PTFE sliding surfaces to develop the translational movement capacity. M_u in the bearing pad results in edge bearing stress on the PTFE in addition to the average compressive stress. The PTFE on CDP pads is unconfined, and this moment may limit the bearing stress on the PTFE to a stress somewhat smaller than permitted on the CDP alone.

14.6.4—Fabrication, Installation, Testing, and Shipping

The provisions for fabrication, installation, testing, and shipping of bearings, specified in Section 18, “Bearing Devices,” of the *AASHTO LRFD Bridge Construction Specifications*, shall apply.

The setting temperature of the bridge or any component thereof shall be taken as the actual air temperature averaged over the 24-hour period immediately preceding the setting event.

14.6.5—Seismic and Other Extreme Event Provisions for Bearings

14.6.5.1—General

This Article shall apply to the analysis, design and detailing of bearings to accommodate the effects of earthquakes and, as appropriate, other extreme events for which the horizontal loading component is very large.

These provisions shall be applied in addition to all other applicable code requirements. The bearing-type selection shall consider the criteria described in Article 14.6.5.3 in the early stages of design.

14.6.5.2—Applicability

These provisions shall apply to pin, roller, rocker, and bronze or copper-alloy sliding bearings, elastomeric bearings, spherical bearings, and pot and disc bearings in common slab-on-girder bridges but not to isolation-type bearings or structural fuse bearings designed primarily for the effects of extreme event dynamic horizontal loadings.

Although the strategy taken herein assumes that inelastic action is confined to properly detailed hinge areas in substructures, alternative concepts that utilize movement at the bearings to dissipate extreme event horizontal and/or vertical forces may also be considered. Where alternate strategies may be used, all ramifications of the increased movements and the predictability of the associated forces and transfer of forces shall be considered in the design and details.

C14.6.4

Some jurisdictions have provided additional guidance beyond that provided in the *AASHTO LRFD Bridge Construction Specifications* with respect to the fabrication, installation, testing, and shipping of multirotational-type bearings (SCEF, 1991).

Setting temperature is used in installing expansion bearings.

An offset chart for girder erection and alignment of the bearings is recommended to account for uncertainty in the setting temperature at the time of design. Offset charts should be defined in appropriate increments and included in the design drawings so that the position of the bearing can be adjusted to account for differences between setting temperature and an assumed design installation temperature.

C14.6.5.1

Extreme events other than earthquakes for which the horizontal loading component is very large include vehicle collisions, ship collisions, and high-velocity winds.

C14.6.5.2

Provisions for the design, specification, testing, and acceptance of isolation bearings are given in AASHTO (1999).

14.6.5.3—Design Criteria

The selection, and the seismic or other extreme event horizontal loading design of bearings shall be related to the strength and stiffness characteristics of both the superstructure and the substructure.

Bearing design shall be consistent with the intended seismic or other extreme event response of the whole bridge system.

Where rigid-type bearings are used, the seismic or other horizontal extreme event forces from the superstructure shall be assumed to be transmitted through diaphragms or cross-frames and their connections to the bearings and then to the substructure without reduction due to local inelastic action along that load path. However, forces may be reduced in situations where the end-diaphragms in the superstructure have been specifically designed and detailed for inelastic action, in accordance with generally accepted provisions for ductile end-diaphragms.

As a minimum, bearings, restraints, and anchorages shall be designed to resist the forces specified in Article 3.10.9.

C14.6.5.3

The commentary provided below specifically addresses seismic design considerations. However, it is also applicable to other extreme event horizontal loadings such as vehicle and ship collisions which are dynamic in nature but can have a very short duration. Accounting for the effects of other extreme events such as wind or waves may require special considerations that are not fully addressed in these specifications for bearing design.

Bearings have a significant effect on the overall seismic response of a bridge. They provide the seismic load transfer link between a stiff and massive superstructure and a stiff and massive substructure. As a result, very high (and difficult-to-predict) load concentrations can occur in the bearing components. The primary functions of the bearings are to resist the vertical loads due to dead load and live load and to allow for superstructure movements due to live load and temperature changes. Allowance for translation is made by means of rollers, rocker, or shear deformation of an elastomer, or through the provision of a sliding surface of bronze or copper alloy or PTFE. Allowance for rotation is made by hinges, confined or unconfined elastomers, or spherical sliding surfaces. Resistance to translation is provided by bearing components or additional restraining elements.

Historically, bearings have been very susceptible to seismic loads. Unequal loading during seismic events and much higher loads than anticipated have caused various types and levels of bearing damage. To allow movements, bearings often contain elements vulnerable to high loads and impacts.

The performance of bearings during past earthquakes needs to be evaluated in context with the overall performance of the bridge and the performance of the superstructure and substructure elements connected to the bearings. Rigid bearings have been associated with damage to the end cross-frames and the supporting pier or abutment concrete. In some cases, bearing damage and slippage has prevented more extensive damage.

The criteria for seismic design of bearings should consider the strength and stiffness characteristics of the superstructure and substructure. To minimize damage, the seismic load resisting system made of the end cross-frame or diaphragms, bearings, and substructure should allow a certain degree of energy dissipation, movement, or plastic deformation even if those effects are not quantified as they would be for seismic isolation bearings or structural fuses.

Based on their horizontal stiffness, bearings may be divided into four categories:

- Rigid bearings that transmit seismic loads without any movement or deformations;
- Deformable bearings that transmit seismic loads limited by plastic deformations or restricted slippage of bearing components;

Elastomeric bearings having less than full rigidity, but not designed explicitly as seismic isolators or fuses, may be used under any circumstance. If used, they shall either be designed to accommodate imposed seismic or other horizontal extreme event loads, or, if survival of the elastomeric bearing itself is not required, other means such as restrainers, STUs, widened support lengths, or dampers shall be provided to prevent unseating of the superstructure.

14.7—SPECIAL DESIGN PROVISIONS FOR BEARINGS

14.7.1—Metal Rocker and Roller Bearings

14.7.1.1—General

The rotation axis of the bearing shall be aligned with the axis about which the largest rotations of the supported member occur. Provision shall be made to ensure that the bearing alignment does not change during the life of the bridge. Multiple roller bearings shall be connected by gearing to ensure that individual rollers remain parallel to each other and at their original spacing.

Metal rocker and roller bearings shall be detailed so that they can be easily inspected and maintained.

Rockers should be avoided wherever practical and, when used, their movements and tendency to tip under seismic actions shall be considered in the design and details.

- Seismic isolation type bearings that transmit reduced seismic loads, limited by energy dissipation; and,
- Structural fuses that are designed to fail at a prescribed load.

For the deformable-type bearing, limited and repairable bearing damage and displacement may be allowed for the design earthquake.

When both the superstructure and the substructure components adjacent to the bearing are very stiff, a deformable-type bearing should be considered.

Seismic isolation-type bearings are not within the scope of these provisions, but they should also be considered.

Elastomeric bearings have been demonstrated to result in reduced force transmission to substructure.

A bearing may also be designed to act as a “structural fuse” that will fail at a predetermined load changing the articulation of the structure, possibly changing its period and hence seismic response, and probably resulting in increased movements. This strategy is permitted as an alternative to these provisions under Article 14.6.5.2. Such an alternative would require full consideration of forces and movements and of bearing repair/replacement details. It also requires the designer to address the inherent difficulty of detailing a structural element to fail reliably at predetermined load.

C14.7.1.1

Cylindrical bearings contain no deformable parts and are susceptible to damage if the superstructure rotates about an axis perpendicular to the axis of the bearing. Thus, they are unsuitable for bridges in which the axis of rotation may vary significantly under different situations, such as bridges with a large skew. They are also unsuitable for use in seismic regions because the transverse shear caused by earthquake loading can cause substantial overturning moment.

Good maintenance is essential if mechanical bearings are to perform properly. Dirt attracts and holds moisture, which, combined with high local contact stresses, can promote stress corrosion. Metal bearings, in particular, must be designed for easy maintenance.

Rockers can be suitable for applications in which the horizontal movement of the superstructure, relative to the substructure, is well within the available movement range after consideration of other applicable movements.

14.7.1.2—Materials

Rocker and roller bearings shall be made of stainless steel conforming to ASTM A240, as specified in Article 6.4.7, or of structural steel conforming to AASHTO M 169 (ASTM A108), M 102M/M 102 (ASTM A668/A668M), or M 270M/M 270 (ASTM A709/A709M), Grades 36, 50, or 50W. Material properties of these steels shall be taken as specified in Table 6.4.1-1 and Table 6.4.2-1.

14.7.1.3—Geometric Requirements

The dimensions of the bearing shall be chosen taking into account both the contact stresses and the movement of the contact point due to rolling.

Each individual curved contact surface shall have a constant radius. Bearings with more than one curved surface shall be symmetric about a line joining the centers of their two curved surfaces.

If pintles or gear mechanisms are used to guide the bearing, their geometry should be such as to permit free movement of the bearing.

Bearings shall be designed to be stable. If the bearing has two separate cylindrical faces, each of which rolls on a flat plate, stability may be achieved by making the distance between the two contact lines no greater than the sum of the radii of the two cylindrical surfaces.

14.7.1.4—Contact Stresses

At the service limit state, the contact load, P_s , shall satisfy:

- For cylindrical surfaces:

$$P_s \leq 8 \frac{WD_1}{\left(1 - \frac{D_1}{D_2}\right)} \left(\frac{F_y^2}{E_s}\right) \quad (14.7.1.4-1)$$

- For spherical surfaces:

$$P_s \leq 40 \left(\frac{D_1}{1 - \frac{D_1}{D_2}}\right)^2 \frac{F_y^3}{E_s^2} \quad (14.7.1.4-2)$$

where:

D_1 = diameter of the rocker or roller surface (in.)

C14.7.1.2

Carbon steel has been the traditional steel used in mechanical bearings because of its good mechanical properties. Surface hardening may be considered. Corrosion resistance is also important. The use of stainless steel for the contact surfaces may prove economical when life-cycle costs are considered. Weathering steels should be used with caution as their resistance to corrosion is often significantly reduced by mechanical wear at the surface.

C14.7.1.3

The choice of radius for a curved surface is a compromise: a large radius results in low contact stresses but large rotations of the point of contact and vice versa. The latter could be important if, for example, a rotational bearing is surmounted by a PTFE slider because the PTFE is sensitive to eccentric loading.

A cylindrical roller is in neutral equilibrium. The provisions for bearings with two curved surfaces achieves at least neutral, if not stable, equilibrium.

C14.7.1.4

The service limit state loads are limited so that the contact causes calculated shear stresses no higher than $0.55 F_y$ or surface compression stresses no higher than $1.65 F_y$. The maximum compressive stress is at the surface, and the maximum shear stress occurs just below it.

The formulas were derived from the theoretical value for contact stress between elastic bodies (Roark and Young, 1976). They are based on the assumption that the width of the contact area is much less than the diameter of the curved surface.

If two surfaces have curves of the opposite sign, the value of D_2 is negative. This would be an unusual situation in bridge bearings.

If careful inspection indicates that existing bearings which do not satisfy these provisions are performing well and there is no evidence of rutting or ridging, which may be evidence of local yielding, then reuse of the bearing may be viable. Evaluation of roller and rocker bearings with flat mating surfaces may proceed using the following historical provision:

Bearing per linear in. on expansion rockers and rollers at the service limit state shall not exceed the values obtained by the following formulas:

Diameters up to 25.0 in.

$$p = \frac{F_y - 13}{20} (0.6d) \quad (\text{C14.7.1.4-1})$$

Diameters 25.0 to 125.0 in.

$$p = \frac{F_y - 13}{20} 3\sqrt{d} \quad (\text{C14.7.1.4-2})$$

where:

p = allowable bearing at the service limit state (kip/in.)

d = diameter of rocker or roller (in.)

F_y = specified minimum yield strength of the weakest steel at the contact surface (ksi)

If loads are increased significantly by the rehabilitation or the mating surface is curved, complying with the current provisions may be more appropriate.

The two diameters have the same sign if the centers of the two curved surfaces in contact are on the same side of the contact surface, such as is the case when a circular shaft fits in a circular hole.

D_2 = diameter of the mating surface (in.) taken as:

- Positive if the curvatures have the same sign, and
- Infinite if the mating surface is flat.

F_y = specified minimum yield strength of the weakest steel at the contact surface (ksi)

E_s = Young's modulus for steel (ksi)

W = width of the bearing (in.)

14.7.2—PTFE Sliding Surfaces

PTFE may be used in sliding surfaces of bridge bearings to accommodate translation or rotation. All PTFE surfaces other than guides shall satisfy the requirements specified herein. Curved PTFE surfaces shall also satisfy Article 14.7.3.

14.7.2.1—PTFE Surface

The PTFE surface shall be made from pure virgin PTFE resin satisfying the requirements of ASTM D4894 or D4895. It shall be fabricated as unfilled sheet, filled sheet, or fabric woven from PTFE and other fibers.

Unfilled sheets shall be made from PTFE resin alone. Filled sheets shall be made from PTFE resin uniformly blended with glass fibers, carbon fibers, or other chemically inert filler. The filler content shall not exceed 15 percent for glass fibers and 25 percent for carbon fibers.

C14.7.2

PTFE, is also known as TFE and is commonly used in bridge bearings in the United States. This Article does not cover guides. The friction requirements for guides are less stringent, and a wider variety of materials and fabrication methods can be used for them.

C14.7.2.1

PTFE may be provided in sheets or in mats woven from fibers. The sheets may be filled with reinforcing fibers to reduce creep, i.e., cold flow, and wear, or they may be made from pure resin. The friction coefficient depends on many factors, such as sliding speed, contact pressure, lubrication, temperature, and properties such as the finish of the mating surface (Campbell and Kong, 1987). The material properties that influence the friction coefficient are not well understood, but the crystalline structure of the PTFE is known to be important, and it is strongly affected by the quality control exercised during the manufacturing process.

Sheet PTFE may contain dimples to act as reservoirs for lubricant. Unlubricated PTFE may also contain dimples. Their diameter shall not exceed 0.32 in. at the surface of the PTFE, and their depth shall be not less than 0.08 in. and not more than half the thickness of the PTFE. The reservoirs shall be uniformly distributed over the surface area and shall cover more than 20 percent but less than 30 percent of the contact surface. Dimples should not be placed to intersect the edge of the contact area. Lubricant shall be silicone grease, which satisfies Society of Automotive Engineers Specification SAE-AS8660.

Woven fiber PTFE shall be made from pure PTFE fibers. Reinforced woven fiber PTFE shall be made by interweaving high-strength fibers, such as glass, with the PTFE in such a way that the reinforcing fibers do not appear on the sliding face of the finished fabric.

14.7.2.2—Mating Surface

The PTFE shall be used in conjunction with a mating surface. Flat mating surfaces shall be stainless steel, and curved mating surfaces shall be stainless steel or anodized aluminum. Flat surfaces shall be stainless steel, Type 304, conforming to either ASTM A167 or A264, and shall be provided with a surface finish of 8.0 μ -in. RMS or better. Finishes on curved metallic surfaces shall not exceed 16.0 μ -in. RMS. The mating surface shall be large enough to cover the PTFE at all times.

14.7.2.3—Minimum Thickness

14.7.2.3.1—PTFE

For all applications, the thickness of the PTFE shall be at least 0.0625 in. after compression. Recessed sheet PTFE shall be at least 0.1875 in. thick when the maximum dimension of the PTFE is less than or equal to 24.0 in., and 0.25 in. when the maximum dimension of the PTFE is greater than 24.0 in. Woven fabric PTFE, which is mechanically interlocked over a metallic substrate, shall have a minimum thickness of 0.0625 in. and a maximum thickness of 0.125 in. over the highest point of the substrate.

Unfilled dimples can act as reservoirs for contaminants (dust, etc.) which can help to keep these contaminants from the contact surface.

C14.7.2.2

Stainless steel is the most commonly used mating surface for PTFE sliding surfaces. Anodized aluminum has been sometimes used in spherical and cylindrical bearings produced in other countries and may be considered if documentation of experience, acceptable to the Owner, is provided. The finish of this mating surface is extremely important because it affects the coefficient of friction. ASTM A240, Type 304, stainless steel, with a surface finish of 16.0 μ -in. RMS or better, is appropriate, but the surface measurements are inherently inexact, and hence it is not a specified alternative. Friction testing is required for the PTFE and its mating surface because of the many variables involved.

C14.7.2.3.1

A minimum thickness is specified to ensure uniform bearing and to allow for wear.

During the first few cycles of movement, small amounts of PTFE transfer to the mating surface and contribute to the very low friction achieved subsequently. This wear is acceptable and desirable.

PTFE continues to wear with time (Campbell and Kong, 1987) and movement; wear is exacerbated by deteriorated or rough surfaces. Wear is undesirable because it usually causes higher friction and reduces the thickness of the remaining PTFE. Unlubricated, flat PTFE wears more severely than the lubricated material. The evidence on the rate of wear is tentative. High travel speeds, such as those associated with traffic movements, appear to be more damaging than the slow ones due to thermal movements. However, they may be avoided by placing the sliding surface on an elastomeric bearing that will absorb small longitudinal movements. No further allowance for wear is made in this Specification due to the limited research available to quantify or estimate the wear as a function of time and travel. However, wear may

ultimately cause the need for replacement of the PTFE, so it is wise to allow for future replacement in the original design.

14.7.2.3.2—Stainless Steel Mating Surfaces

The thickness of the stainless steel mating surface shall be at least 16 gage when the maximum dimension of the surface is less than or equal to 12.0 in. and at least 13 gage when the maximum dimension is larger than 12.0 in.

Backing plate requirements shall be taken as specified in Article 14.7.2.6.2.

14.7.2.4—Contact Pressure

The contact stress between the PTFE and the mating surface shall be determined at the service limit state using the nominal area.

The average contact stress shall be computed by dividing the load by the projection of the contact area on a plane perpendicular to the direction of the load. The contact stress at the edge shall be determined by taking into account the maximum moment transferred by the bearing assuming a linear distribution of stress across the PTFE.

Stresses shall not exceed those given in Table 14.7.2.4-1. Permissible stresses for intermediate filler contents shall be obtained by linear interpolation within Table 14.7.2.4-1.

C14.7.2.3.2

The minimum thickness requirements for the mating surface are intended to prevent it from wrinkling or buckling. This surface material is usually quite thin to minimize cost of the highly finished mating surface. Some mating surfaces, particularly those with curved surfaces, are made of carbon steel on which a stainless steel weld is deposited. This welded surface is then finished and polished to achieve the desired finish. Some jurisdictions require a minimum thickness of 0.094 in. for welded overlay after grinding and polishing.

C14.7.2.4

The average contact stress shall be determined by dividing the load by the projection of the contact area onto a plane perpendicular to the direction of the load. The edge contact stress shall be determined based on the service limit state load and the maximum service limit state moment transferred by the bearing.

The contact pressure must be limited to prevent excessive creep or plastic flow of the PTFE, which causes the PTFE disc to expand laterally under compressive stress and may contribute to separation or bond failure. The lateral expansion is controlled by recessing the PTFE into a steel plate or by reinforcing the PTFE, but there are adverse consequences associated with both methods. Edge loading may be particularly detrimental because it causes large stress and potential flow in a local area near the edge of the material in hard contact between steel surfaces. The average and edge contact pressure in Table 14.7.2.4-1 are in appropriate proportions to one another relative to the currently available research. Better data may become available in the future. These are in the lower range of those used in Europe.

Table 14.7.2.4-1—Maximum Contact Stress for PTFE at the Service Limit State (ksi)

Material	Average Contact Stress (ksi)		Edge Contact Stress (ksi)	
	Permanent Loads	All Loads	Permanent Loads	All Loads
Unconfined PTFE:				
Unfilled Sheets	1.5	2.5	2.0	3.0
Filled Sheets with Maximum Filler Content	3.0	4.5	3.5	5.5
Confined Sheet PTFE	3.0	4.5	3.5	5.5
Woven PTFE Fiber over a Metallic Substrate	3.0	4.5	3.5	5.5
Reinforced Woven PTFE over a Metallic Substrate	4.0	5.5	4.5	7.0

14.7.2.5—Coefficient of Friction

The service limit design coefficient of friction of the PTFE sliding surface shall be taken as specified in Table 14.7.2.5-1. Intermediate values may be determined by interpolation. The coefficient of friction shall be determined by using the stress level associated with the applicable load combination specified in Table 3.4.1-1. Lesser values may be used if verified by tests.

Where friction is required to resist nonseismic loads, the design coefficient of friction under dynamic loading may be taken as not more than ten percent of the values listed in Table 14.7.2.5-1 for the bearing stress and PTFE type indicated.

The coefficients of friction in Table 14.7.2.5-1 are based on a 8.0 μ -in. finish mating surface. Coefficients of friction for rougher surface finishes must be established by test results in accordance with the *AASHTO LRFD Bridge Construction Specifications*, Chapter 18.

The contract documents shall require certification testing from the production lot of PTFE to ensure that the friction actually achieved in the bearing is appropriate for the bearing design.

C14.7.2.5

The friction factor decreases with lubrication and increasing contact stress but increases with sliding velocity (Campbell and Kong, 1987). The coefficient of friction also tends to increase at low temperatures. Static friction is larger than dynamic friction, and the dynamic coefficient of friction is larger for the first cycle of movement than it is for later cycles. Friction increases with increasing roughness of the mating surface and decreasing temperature. The friction factors used in the earlier editions of the AASHTO Standard Specifications are suitable for use with dimpled, lubricated PTFE. They are too small for the flat, dry PTFE commonly used in the United States. These Specifications have been changed to recognize this fact. Nearly all research to date has been performed on dimpled, lubricated PTFE. The coefficients of friction given in Table 14.7.2.5-1 are not applicable to high-velocity movements such as those occurring in seismic events. Seismic velocity coefficients of friction must be determined in accordance with the *AASHTO Guide Specifications for Seismic Isolation Design*. Coefficients of friction, somewhat smaller than those given in Table 14.7.2.5-1, are possible with care and quality control.

Certification testing from the production lot is essential for PTFE sliding surfaces primarily to ensure that the friction actually achieved in the bearing is appropriate for the bearing design. Testing is the only reliable method for certifying the coefficient of friction and bearing behavior.

Contamination of the sliding surface with dirt and dust increases the coefficient of friction and increases the wear of the PTFE. To prevent contamination, the bearing should be sealed by the manufacturer and not separated at the construction site. To prevent contamination and gouging of the PTFE, the stainless steel should normally be on top and should be larger than the PTFE, plus its maximum travel.

Woven PTFE is sometimes formed by weaving pure PTFE strands with a reinforcing material. These reinforcing strands may increase the resistance to creep and cold flow and can be woven so that reinforcing strands do not appear on the sliding surface. This separation is necessary if the coefficients of friction provided in Table 14.7.2.5-1 are to be used.

If there is no lubricant in the dimples, the dimples tend to flatten out filling the dimples, resulting in a surface much like unfilled PTFE.

Table 14.7.2.5-1—Design Coefficients of Friction—Service Limit State

	Pressure (ksi)	Coefficient of Friction			
		0.5	1.0	2.0	>3.0
Type PTFE	Temperature (°F)				
Dimpled Lubricated	68	0.04	0.030	0.025	0.020
	-13	0.06	0.045	0.040	0.030
	-49	0.10	0.075	0.060	0.050
Unfilled or Dimpled Unlubricated	68	0.08	0.070	0.050	0.030
	-13	0.20	0.180	0.130	0.100
	-49	0.20	0.180	0.130	0.100
Filled	68	0.24	0.170	0.090	0.060
	-13	0.44	0.320	0.250	0.200
	-49	0.65	0.550	0.450	0.350
Woven	68	0.08	0.070	0.060	0.045
	-13	0.20	0.180	0.130	0.100
	-49	0.20	0.180	0.130	0.100

14.7.2.6—Attachment

14.7.2.6.1—PTFE

Sheet PTFE confined in a recess in a rigid metal backing plate for one-half its thickness may be bonded or unbonded.

Sheet PTFE that is not confined shall be bonded to a metal surface or an elastomeric layer with a Shore A durometer hardness of at least 90 by an approved method.

Woven PTFE on a metallic substrate shall be attached to the metallic substrate by mechanical interlocking that can resist a shear force no less than 0.10 times the applied compressive force.

C14.7.2.6.1

Recessing is the most effective way of preventing creep in unfilled PTFE. The PTFE discs may also be bonded into the recess, but this is optional and the benefits are debatable. Bonding helps to retain the PTFE in the recess during the service life of the bridge, but it makes replacement of the disc more difficult. If the adhesive is not applied uniformly it can cause an uneven PTFE sliding surface that could lead to premature wear. Some manufacturers cut the PTFE slightly oversize and pre-cool it before installation because this results in a tighter fit at room temperature.

Sometimes PTFE is bonded to the top cover layer of an elastomeric bearing. This layer should be relatively thick and hard to avoid rippling of the PTFE (Roeder et al., 1987). PTFE must be etched prior to epoxy bonding in order to obtain good adhesion. However, ultra-violet light attacks the etching and can lead to delamination, so PTFE exposed to ultra-violet light should not be attached by bonding alone.

14.7.2.6.2—Mating Surface

The mating surface for flat sliding surfaces shall be attached to a backing plate by welding in such a way that it remains flat and in full contact with its backing plate throughout its service life. The weld shall be detailed to form an effective moisture seal around the entire perimeter of the mating surface to prevent interface corrosion. The attachment shall be capable of resisting the maximum friction force that can be developed by the bearing under service limit state load combinations. The welds used for the attachment shall be clear of the contact and sliding area of the PTFE surface.

C14.7.2.6.2

The restrictions on the attachment of the mating surface are primarily intended to ensure that the surface is flat and retains uniform contact with the PTFE at all times, without adversely affecting the friction of the surface or gouging or cutting the PTFE.

The mating surface of curved sliding surfaces should be machined to the required surface finish from a single piece.

14.7.3—Bearings with Curved Sliding Surfaces

14.7.3.1—General

Bearings with curved sliding surfaces shall consist of two metal parts with matching curved surfaces and a low friction sliding interface. The curved surfaces may be either cylindrical or spherical. The material properties, characteristics, and frictional properties of the sliding interface shall satisfy the requirements specified in Articles 14.7.2 and 14.7.7.

The two surfaces of a sliding interface shall have equal nominal radii.

14.7.3.2—Bearing Resistance

The radius of the curved surface shall be large enough to ensure that the total compressive load at the service limit state on the horizontal projected area of the bearing, P_s , is less than or equal to the average allowable load as computed from the service stress specified in Articles 14.7.2.4 or 14.7.7.3.

- For cylindrical bearings:

$$P_s \leq \phi DW \sigma_{ss} \quad (14.7.3.2-1)$$

- For spherical bearings:

$$P_s \leq \phi \frac{\pi D^2 \sigma_{ss}}{4} \quad (14.7.3.2-2)$$

where:

P_s = total compressive load from applicable service load combinations in Table 3.4.1-1 (kip)

D = diameter of the projection of the loaded surface of the bearing in the horizontal plane (in.)

C14.7.3.1

These provisions are directed primarily toward spherical or cylindrical bearings with bronze or PTFE sliding surfaces.

Some jurisdictions require that the minimum center thickness of concave spherical surfaces be at least 0.75 in. and that a minimum vertical clearance between the rotating and nonrotating parts be as given by Eqs. C14.7.3.1-1 or C14.7.3.1-2 but not less than 0.125 in.

- For rectangular spherical or curved bearings:

$$c = 0.7D\theta_u + 0.125 \quad (C14.7.3.1-1)$$

- For round spherical or round bearings:

$$c = 0.5D\theta_u + 0.125 \quad (C14.7.3.1-2)$$

where:

θ_u = design rotation from applicable strength load combinations in Table 3.4.1-1 or Article 14.4.2.2.1 (rad.)

Similarly, the minimum edge thickness on the convex surface has sometimes been limited to 0.75 in. for bearing on concrete and 0.50 in. for bearing on steel.

C14.7.3.2

The geometry of a spherical bearing controls its ability to resist lateral loads, its moment-rotation behavior, and its frictional characteristics. The geometry is relatively easy to define, but it has some consequences that are not widely appreciated. The stress may vary over the contact surface of spherical or cylindrical bearings. Cylindrical and spherical surfaces cannot be machined as accurately as a flat smooth surface. It is important that the radius of the convex and concave surfaces be within appropriate limits. If these limits are exceeded the bronze may crack due to hard bearing contact, or there may be excessive wear and damage due to creep or cold flow of the PTFE. The stress limits used in this Section are based on average contact stress levels.

σ_{SS} = maximum average contact stress at the service limit state permitted on PTFE by Table 14.7.2.4-1 or on bronze by Table 14.7.7.3-1 (ksi)

W = length of cylinder (in.)

ϕ = resistance factor taken as 1.0

14.7.3.3—Resistance to Lateral Load

Where bearings are required to resist horizontal loads at the service limit state, an external restraint system shall be provided or:

- For a cylindrical sliding surface, the horizontal load shall satisfy:

$$H_s \leq 2RW\sigma_{SS} \sin(\psi - \beta - \theta_u) \sin \beta \quad (14.7.3.3-1)$$

- For a spherical surface, the horizontal load shall satisfy:

$$H_s \leq \pi R^2 \sigma_{SS} \sin(\psi - \beta - \theta_u) \sin \beta \quad (14.7.3.3-2)$$

in which:

$$\beta = \tan^{-1} \left(\frac{H_s}{P_D} \right) \quad (14.7.3.3-3)$$

and

$$\psi = \sin^{-1} \left(\frac{L}{2R} \right) \quad (14.7.3.3-4)$$

where:

H_s = horizontal load from applicable service load combinations in Table 3.4.1-1 (kip)

L = projected length of the sliding surface perpendicular to the rotation axis (in.)

P_D = compressive load at the service limit state (load factor = 1.0) due to permanent loads (kip)

R = radius of curved sliding surface (in.)

W = length of cylindrical surface (in.)

β = angle between the vertical and resultant applied load (rad.)

θ_u = maximum strength limit state design rotation angle specified in Article 14.4.2.2.1 (rad.)

C14.7.3.3

The geometry of a curved bearing combined with gravity loads can provide considerable resistance to lateral load. An external restraint is often a more reliable method of resisting large lateral loads at the service and strength limit states, and at the extreme event limit state when the bearing is not intended to act as a fuse or irreparable damage is not permitted.

The applied loads for determination of the angle β and the applied load check are at the service limit state because the stress limits, σ_{SS} , are service-based. The rotation at the strength limit state is utilized because bearings with curved sliding surfaces are susceptible to more serious consequences if overloaded or over rotated.

The geometry of a cylindrical sliding bearing is shown in the deformed position in Figure C14.7.3.3-1.

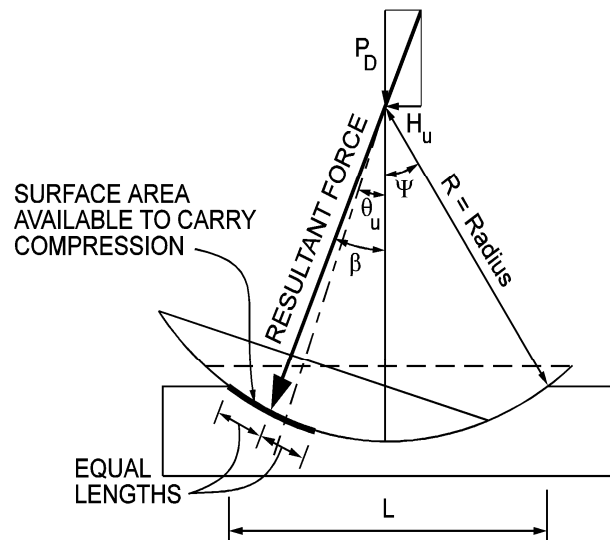

Figure C14.7.3.3-1—Bearing Geometry

σ_{SS} = maximum average contact stress at the service limit state permitted on PTFE by Table 14.7.2.4-1 or on bronze by Table 14.7.7.3-1 (ksi)

Ψ = subtended semiangle of the curved surface (rad.)

14.7.4—Pot Bearings

14.7.4.1—General

Where pot bearings are provided with a PTFE slider to provide for both rotation and horizontal movement, such sliding surfaces and any guide systems shall be designed in accordance with the provisions of Articles 14.7.2 and 14.7.9.

The rotational elements of the pot bearing shall consist of at least a pot, a piston, an elastomeric disc, and sealing rings.

For the purpose of establishing the forces and deformations imposed on a pot bearing, the axis of rotation shall be taken as lying in the horizontal plane at midheight of the elastomeric disc.

The minimum vertical load on a pot bearing should not be less than 20 percent of the vertical design load.

14.7.4.2—Materials

The elastomeric disc shall be made from a compound based on virgin natural rubber or virgin neoprene conforming to the requirements of Section 18.3 of the *AASHTO LRFD Bridge Construction Specifications*. The nominal hardness shall lie between 50 and 60 on the Shore A scale.

The pot and piston shall be made from structural steel conforming to AASHTO M 270M/M 270 (ASTM A709/A709); Grades 36, 50, or 50W; or from stainless steel conforming to ASTM A240. The finish of surfaces in contact with the elastomeric pad shall be smoother than 60 μ -in. The yield strength and hardness of the piston shall not exceed that of the pot.

Brass sealing rings satisfying Articles 14.7.4.5.2 and 14.7.4.5.3 shall conform to ASTM B36 (half hard) for rings of rectangular cross-section, and Federal Specification QQB626, Composition 2, for rings of circular cross-section.

14.7.4.3—Geometric Requirements

The depth of the elastomeric disc, h_r , shall satisfy:

$$h_r \geq 3.33D_p\theta_u \quad (14.7.4.3-1)$$

where:

D_p = internal diameter of pot (in.)

θ_u = maximum strength limit state design rotation angle specified in Article 14.4.2.2.1 (rad.)

C14.7.4.2

Softer elastomers permit rotation more readily and are preferred.

Corrosion resistant steels, such as AASHTO M 270M/M 270 (ASTM A709/A709), Grade 50W, are not recommended for applications where they may come into contact with saltwater or be permanently damp, unless their whole surface is completely corrosion protected. Most pot bearings are machined from a solid plate, so use of high-strength steel to decrease the wall thickness results in only a very small reduction in volume of material used.

Other properties, such as corrosion resistance, ease of machining, electrochemical compatibility with steel girders, availability, and price should also be considered. The provision on relative hardness is mentioned to avoid wear or damage on the inside surface of the pot and the consequent risk of seal failure.

The choice of brass for sealing rings reflects present practice.

C14.7.4.3

The requirements of this Article are intended to prevent the seal from escaping and the bearing from locking up even under the most adverse conditions. Use of the design rotation, θ_u , means that the designer should account for both the anticipated movements due to loads and those due to fabrication and installation tolerances, including the rotation imposed on the bearing due to out-of-level of other bridge components, such as undersides of prefabricated girders, and permissible misalignments during construction. Vertical deflection

The dimensions of the elements of a pot bearing shall satisfy the following requirements under the least favorable combination of strength limit state displacements and rotations:

- The pot shall be deep enough to permit the seal and piston rim to remain in full contact with the vertical face of the pot wall, and
- Contact or binding between metal components shall not prevent further displacement or rotation.

caused by compressive load should also be taken into account because it will reduce the available clearance. Anchor bolts projecting above the base plate should be taken into consideration when clearance is determined.

Rotation capacity can be increased by using a deeper pot, a thicker elastomeric pad, and a larger vertical clearance between the pot wall and the piston or slider. The minimum thickness of the pad specified herein results in edge deflections due to rotation no greater than 15 percent of the nominal pad thickness. Figure C14.7.4.3-1 and Eqs. C14.7.4.3-1 and C14.7.4.3-2 may be used to verify clearance.

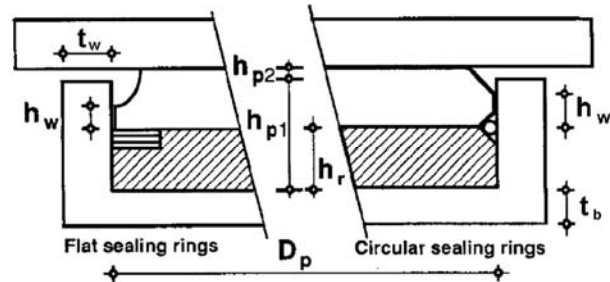

Figure C14.7.4.3-1—Pot Bearing—Critical Dimensions for Clearances

The pot cavity depth, h_{p1} , may be determined as:

$$h_{p1} \geq (0.5D_p \theta_u) + h_r + h_w \quad (\text{C14.7.4.3-1})$$

where:

h_r = depth of elastomeric disc (in.)

h_w = height from top of rim to underside of piston (in.)

The vertical clearance between top of piston and top of pot wall, h_{p2} may be determined as:

$$h_{p2} \geq R_o \theta_u + 2\delta_u + 0.125 \quad (\text{C14.7.4.3-2})$$

where:

δ_u = vertical deflection from applicable strength load combinations in Table 3.4.1-1 (in.)

R_o = radial distance from center of pot to object in question (e.g., pot wall, anchor bolt, etc.) (in.)

Note that Eq. C14.7.4.3-1 does not contain any allowance for vertical deflection δ_u . This omission is conservative. The design rotation, θ_u , already represents an extreme rotation for use with the strength limit state and requires no further factoring.

δ_u and θ_u may also be considered at the extreme event limit state.

Thicker pads with deeper pots cause smaller strains in the elastomer, and they appear to experience less wear and abrasion. Recessing of the rings into the pad is necessary for satisfactory pad performance, but it also decreases the effective thickness of the pad at that location. Further, the recess has sometimes been cut into the pad, and this cut appears to make the pad susceptible to additional damage. Therefore, it is generally better to use a deeper pot and thicker pad even though this leads to greater material and machining costs.

14.7.4.4—Elastomeric Disc

The average stress on the elastomer at the service limit state should not exceed 3.5 ksi.

To facilitate rotation, the top and bottom surfaces of the elastomer shall be treated with a lubricant that is not detrimental to the elastomer. Alternatively, thin PTFE discs may be used on the top and bottom of the elastomer.

C14.7.4.4

The average stress on the elastomeric disc is largely limited by the seal's ability to prevent escape of the elastomer. The 3.5 ksi level has been used as a practical upper limit for some years, and most bearings have performed satisfactorily but a few seal failures have occurred. The experimental research of NCHRP 10-20A showed that greater wear and abrasion due to cyclic rotation occurred when higher stress levels are employed, but this correlation is not strong. As a result, the 3.5 ksi stress limit is retained as a practical design limit.

Lubrication helps prevent abrasion of the elastomer during cyclic rotation, however, research has shown that the beneficial effect of the lubrication tends to be lost with time. Silicon grease has been used with success. It performed well in experiments and is recommended. Thin sheets of PTFE have also been used. These sheets performed quite well in experimental studies, but they are less highly recommended because there is a concern that they may wrinkle and become ineffective. Powdered graphite has been used but has not performed well in rotation experiments. As a result, silicon grease is the preferred lubricant, and powdered graphite is not recommended. PTFE discs are permitted as a method of lubrication, but the user should be aware that some problems have been reported.

14.7.4.5—Sealing Rings

14.7.4.5.1—General

A seal shall be used between the pot and the piston. At the service limit state seals shall be adequate to prevent escape of elastomer under compressive load and simultaneously applied cyclic rotations. At the strength limit state, seals shall also be adequate to prevent escape of elastomer under compressive load and simultaneously applied static rotation.

Brass rings satisfying the requirements of either Articles 14.7.4.5.2 or 14.7.4.5.3 may be used without testing to satisfy the above requirements. The Engineer may approve other sealing systems on the basis of experimental evidence.

C14.7.4.5.1

Failure of seals has been one of the most common problems in pot bearings. Multiple flat brass rings, circular brass rod formed and brazed into a ring, and proprietary plastic rings have been found to be successful. Experimental research suggests that solid circular brass rings provide a tight fit and prevent leakage of the elastomer, but they experience severe wear during cyclic rotation. Experiments suggest that flat brass rings are somewhat more susceptible to elastomer leakage and fracture, but they are less prone to wear. PTFE rings should not be used. The rings should preferably be recessed into the elastomer or vulcanized to it in order to minimize distortion of the elastomer.

Cyclic rotation of the bearing due to temperature variations or traffic loading can cause chafing of the elastomer against the pot wall, which can give rise to some loss of elastomer past the seal. The detail design of the sealing system is important in preventing this. The details of the tests for alternative sealing systems are left to the discretion of the Engineer. However, tests should include cyclic rotation.

14.7.4.5.2—Rings with Rectangular Cross-Sections

Three rectangular rings shall be used. Each ring shall be circular in plan but shall be cut at one point around its circumference. The faces of the cut shall be on a plane at 45 degrees to the vertical and to the tangent of the circumference. The rings shall be oriented so that the cuts on each of the three rings are equally spaced around the circumference of the pot.

The width of each ring shall not be less than either $0.02 D_p$ or 0.25 in. and shall not exceed 0.75 in. The depth of each shall not be less than 0.2 times its width.

14.7.4.5.3—Rings with Circular Cross-Sections

One circular closed ring shall be used with an outside diameter of D_p . It shall have a cross-sectional diameter not less than either $0.0175 D_p$ or 0.15625 in.

14.7.4.6—Pot

The pot shall consist at least of a wall and base. All elements of the pot shall be designed to act as a single structural unit.

The minimum thickness of a base bearing directly against concrete or grout shall satisfy:

- $t_b \geq 0.06 D_p$ and (14.7.4.6-1)

- $t_b \geq 0.75$ in. (14.7.4.6-2)

The thickness of a base bearing directly on steel girders or load distribution plates shall satisfy:

- $t_b \geq 0.04 D_p$ and (14.7.4.6-3)

- $t_b \geq 0.50$ in. (14.7.4.6-4)

The minimum pot wall thickness, t_w , for an unguided sliding pot bearing shall satisfy:

$$t_w \geq \frac{D_p \sigma_s}{1.25 F_y} \quad (14.7.4.6-5)$$

and:

$$t_w \geq 0.75 \text{ in.} \quad (14.7.4.6-6)$$

C14.7.4.6

Pots are constructed most reliably by machining from a single plate. For very large bearings, this may become prohibitively expensive, so fabrication by welding a ring to a base plate is implicitly accepted. However, the ring must be attached to the plate by a full penetration weld because the wall is subject to significant bending moments where it joins the base plate. The quality of welding should be assured by quality control. The finished inside profile of the pot must satisfy the required shape and tolerances. Straightening and machining may be needed to rectify welding distortions.

The lower bounds on the thickness of the base plate are intended to provide some rigidity to counteract the effects of uneven bearing. If the base plate was to deform significantly, the volume of elastomer would be inadequate to fill the space in the pot, and hard contact could occur between some elements.

Eqs. 14.7.4.6-5 and 14.7.4.6-6 define minimum wall thickness requirements for unguided pot bearings. Eq. 14.7.4.6-5 is based upon hoop strength of the pot walls with the elastomeric disc under hydrostatic compressive stress. This equation is conservative for this application, because it neglects the beneficial effect of the bending strength and stiffness at the pot wall-base interface. However, this equation provides no lateral (horizontal) resistance to the bearing, and it is limited to unguided bearings (Stanton, 1999).

where:

t_w = pot wall thickness (in.)

F_y = yield strength of the steel (ksi)

D_p = internal diameter of pot (in.)

σ_s = average compressive stress due to total load from applicable service load combinations in Table 3.4.1-1 (ksi)

The wall thickness (t_w) and base thickness (t_b) of guided or fixed pots shall also satisfy the requirements of Eq. 14.7.4.7-1 for applicable strength and extreme event load combinations specified in Table 3.4.1-1 which are transferred by the piston to the pot wall.

14.7.4.7—Piston

The piston shall have the same plan shape as the inside of the pot. Its thickness shall be adequate to resist the loads imposed on it, but shall not be less than six percent of the inside diameter of the pot, D_p , except at the rim.

The perimeter of the piston shall have a contact rim through which horizontal loads may be transmitted. In circular pots, its surface may be either cylindrical or spherical. The body of the piston above the rim shall be set back or tapered to prevent binding. The height, w , of the piston rim shall be large enough to transmit the strength and extreme event limit states horizontal forces between the pot and the piston.

Where a mechanical device is used to connect the superstructure to the substructure, it shall be designed to resist the greater of H_u at the support for the strength and extreme event limit states, or 15 percent of the maximum vertical load at the service limit state at that location.

Pot bearings subjected to lateral loads shall be proportioned so that the thickness of the pot wall (t_w) and the pot base (t_b) shall satisfy:

$$t_w, t_b \geq \sqrt{\frac{25H_u \theta_u}{F_y}} \quad (14.7.4.7-1)$$

Pot bearings that transfer load through the piston shall satisfy:

$$h_w \geq \frac{1.5H_u}{D_p F_y} \quad (14.7.4.7-2)$$

$$h_w \geq 0.125 \text{ in.}, \text{ and} \quad (14.7.4.7-3)$$

The limitation of Eq. 14.7.4.6-6 is based upon past manufacturing practice (SCEF, 1991).

The surface finish on the inside of the pot may have considerable impact on bearing performance. A smooth finish reduces rotational resistance and wear and abrasion of the elastomer. It may also improve the performance of the sealing rings, but at present there are no definitive limits as to what the surface finish should ideally be for good bearing performance. Metalization on the inside of the pot tends to cause a rougher surface finish, which leads to significant increases in damage under cyclic rotation; as a result, metalization may not be a good method of protection.

Maximum extreme event limit state forces should be considered when the bearing is not intended to act as a fuse or irreparable damage is not permitted.

C14.7.4.7

The required piston thickness is controlled by rigidity and strength. A central internal guide bar fitted in a slot in the piston causes bending moments that are largest where the piston is weakest. In this case, the piston must also be thick enough to supply an adequate grip length for any bolts used to secure the guide bar.

If the piston rotates while a horizontal load is acting, the piston rim will be subject to bearing stresses due to horizontal load and to shear forces. If the rim surface is cylindrical, contact between it and the pot wall will theoretically be along a line when the piston rotates. In practice, some localized yielding is inevitable. If the rim surface forms part of a sphere, the contact area will be finite, providing less potential for local damage. Damage to the pot wall should be avoided because it will jeopardize the effectiveness of the seal. The dimensions of the rim depend on the contact area, and because this is uncertain, the rim should be designed conservatively. Eq. 14.7.4.7-4 is based on consideration of bearing stresses alone, using a strength limit state horizontal force of 0.15 times the vertical service limit state load, $F_y = 50.0$ ksi and $\phi = 0.9$.

The 15 percent factor applied to the service limit state vertical load, embedded in Eq. 14.7.4.7-4 and used in the design of mechanical devices that connect the superstructure to the substructure, approximates a strength limit state horizontal design force.

Maximum extreme event limit state forces should be considered when the bearing is not intended to act as a fuse or irreparable damage is not permitted. θ_u may also be considered at the extreme event limit state.

The clearance between piston and pot is critical to the proper functioning of the bearing. In most bearings the finished clearance, after anticorrosion coatings have been applied, should be about 0.02 to 0.04 in., a range that is

$$h_w \geq 0.03D_p \quad (14.7.4.7-4)$$

where:

H_u = lateral load from applicable strength and extreme event load combinations in Table 3.4.1-1 (kip)

θ_u = maximum strength limit state design rotation angle specified in Article 14.4.2.2.1 (rad.)

F_y = yield strength of steel (ksi)

D_p = internal diameter of pot (in.)

h_w = height from top of rim to underside of piston (in.)

t_w = pot wall thickness (in.)

t_b = pot base thickness (in.)

The diameter of the piston rim shall be the inside diameter of the pot less a clearance, c . The clearance, c , shall be as small as possible in order to prevent escape of the elastomer but not less than 0.02 in. If the surface of the piston rim is cylindrical, the clearance shall satisfy:

$$c \geq \theta_u \left(h_w - \frac{D_p \theta_u}{2} \right) \quad (14.7.4.7-5)$$

where:

D_p = internal diameter of pot (in.)

h_w = height from top of rim to underside of piston (in.)

θ_u = maximum strength limit state design rotation angle specified in Article 14.4.2.2.1 (rad.)

14.7.5—Steel-Reinforced Elastomeric Bearings— Method B

14.7.5.1—General

Steel-reinforced elastomeric bearings may be designed using either of two methods commonly referred to as Method A and Method B. Where the provisions of this Article are used, the component shall be taken to meet the requirements of Method B. Where the provisions of Article 14.7.6 are used, the component shall be taken to meet the requirements of Method A.

Steel-reinforced elastomeric bearings shall consist of alternate layers of steel reinforcement and elastomer bonded together. In addition to any internal reinforcement, bearings may have external steel load plates bonded to either or both the upper or lower elastomer layers.

easily achievable. The equation for minimum clearance is based on geometry. Eq. 14.7.4.7-5 may occasionally produce a negative number; however, in these instances the minimum value of 0.02 in. controls.

C14.7.5.1

The stress limits associated with Method A usually result in a bearing with a lower capacity than a bearing designed using Method B. This increased capacity resulting from the use of Method B requires additional testing and quality control.

Steel-reinforced elastomeric bearings are treated separately from other elastomeric bearings because of their greater strength and superior performance in practice (Roeder et al., 1987; Roeder and Stanton, 1991). The critical parameter in their design is the shear strain in the elastomer at its interface with the steel plates. Axial load, rotation, and shear deformations all cause such shear strains. The design method (Method B) described in this Section accounts directly for those shear strains and

Tapered elastomer layers shall not be used. All internal layers of elastomer shall be of the same thickness. The top and bottom cover layers shall be no thicker than 70 percent of the internal layers.

The shape factor of a layer of an elastomeric bearing, S_i , shall be taken as the plan area of the layer divided by the area of perimeter free to bulge. Unless noted otherwise, the values of S_i and h_{ri} to be used in Articles 14.7.5 and 14.7.6 for steel-reinforced elastomeric bearing design shall be that for an internal layer. For rectangular bearings without holes, the shape factor of a layer may be taken as:

$$S_i = \frac{LW}{2h_{ri}(L+W)} \quad (14.7.5.1-1)$$

where:

L = plan dimension of the bearing perpendicular to the axis of rotation under consideration (generally parallel to the global longitudinal bridge axis) (in.)

W = plan dimension of the bearing parallel to the axis of rotation under consideration (generally parallel to the global transverse bridge axis) (in.)

h_{ri} = thickness of i th elastomeric layer (in.)

For circular bearings without holes, the shape factor of a layer may be taken as:

$$S_i = \frac{D}{4h_{ri}} \quad (14.7.5.1-2)$$

where:

D = diameter of the projection of the loaded surface of the bearing in the horizontal plane (in.)

provides a versatile means of allowing for different combinations of loadings.

Tapered layers cause larger shear strains and bearings made with them fail prematurely due to delamination or rupture of the reinforcement. All internal layers should be the same thickness because the strength and stiffness of the bearing in resisting compressive load are controlled by the thickest layer.

The shape factor, S_i , is defined in terms of the gross plan dimensions of layer i . Refinements to account for the difference between gross dimensions and the dimensions of the reinforcement are not warranted because quality control on elastomer thickness has a more dominant influence on bearing behavior. Holes are strongly discouraged in steel-reinforced bearings. However, if holes are used, their effect should be accounted for when calculating the shape factor because they reduce the loaded area and increase the area free to bulge. Suitable shape factor formulae are:

- For rectangular bearings:

$$S_i = \frac{LW - \frac{\pi}{4}d^2}{h_{ri}[2L + 2W + \pi d]} \quad (C14.7.5.1-1)$$

- For circular bearings:

$$S_i = \frac{D^2 - \Sigma d^2}{4h_{ri}(D + \Sigma d)} \quad (C14.7.5.1-2)$$

where:

d = the diameter of the hole or holes in the bearing (in.)

Large steel-reinforced elastomeric bearings (defined as those which are thicker than 8 in. or having a plan area greater than 1,000 in.²) are more difficult to fabricate than small ones. The consequences of failure are also likely to be more severe in a large bearing. As such, large bearings should be designed according to Method B, which requires additional testing and quality control.

14.7.5.2—Material Properties

The shear modulus of the elastomer at 73°F shall be used as the basis for design.

The elastomer shall have a specified shear modulus between 0.080 and 0.175 ksi. It shall conform to the requirements of Section 18.2 of the *AASHTO LRFD Bridge Construction Specifications* and AASHTO M 251.

The acceptance criteria in AASHTO M 251 shall be followed which:

- Permits a variation of ± 15 percent from the value specified for shear modulus according to the first and second paragraphs of this Article, and
- Does not permit a shear modulus below 0.080 ksi.

For design purposes, the shear modulus shall be taken as the least favorable of the values in the ranges described above.

Other properties, such as creep deflection, should be obtained from Table 14.7.6.2-1 or from tests conducted using AASHTO M 251.

For the purposes of bearing design, all bridge sites shall be classified as being in temperature Zones A, B, C, D, or E for which design data are given in Table 14.7.5.2-1. In the absence of more precise information, Figure 14.7.5.2-1 may be used as a guide in selecting the zone required for a given region.

Bearings shall be made from AASHTO low-temperature grades of elastomer as defined in Section 18 of the *AASHTO LRFD Bridge Construction Specifications* and AASHTO M 251. The minimum grade of elastomer required for each low-temperature zone shall be taken as specified in Table 14.7.5.2-1.

Any of the three design options listed below may be used:

- Specify the elastomer with the minimum low-temperature grade indicated in Table 14.7.5.2-1 and determine the shear force transmitted by the bearing as specified in Article 14.6.3.1;
- Specify the elastomer with the minimum low-temperature grade for use when special force provisions are incorporated in the design and provide a low friction sliding surface, in which case the bridge shall be designed to withstand twice the design shear force specified in Article 14.6.3.1; or
- Specify the elastomer with the minimum low-temperature grade for use when special force provisions are incorporated in the design but do not provide a low

C14.7.5.2

Shear modulus, G , is the most important material property for design, and it is, therefore, the primary means of specifying the elastomer. Hardness has been widely used in the past, and is still permitted for Method A design, because the test for it is quick and simple. However, the results obtained from it are variable and correlate only loosely with shear modulus.

Materials with a specified shear modulus greater than 0.175 ksi are prohibited because they generally have a smaller elongation at break and greater stiffness and greater creep than their softer counterparts. This inferior performance is generally attributed to the larger amounts of filler present. Their fatigue behavior does not differ in a clearly discernible way from that of softer materials.

The least favorable value for the shear modulus used in design calculations is dependent upon whether the parameter being calculated is conservatively estimated by over- or under-estimating the shear modulus. The forgiving nature of elastomers tends to compensate for service and installation conditions which are less than ideal. (See Article 14.7.5.3.2.) Despite this, the designer should be cautious about specifying a shear modulus which is at or near the specified upper or lower bounds of 0.175 ksi and 0.080 ksi, respectively.

The zones are defined by their extreme low temperatures or the largest number of consecutive days when the temperature does not rise above 32°F, whichever gives the more severe condition.

Shear modulus increases as the elastomer cools, but the extent of stiffening depends on the elastomer compound, time, and temperature. It is, therefore, important to specify a material with low-temperature properties that are appropriate for the bridge site. In order of preference, the low-temperature classification should be based on:

- The 50-yr temperature history at the site,
- A statistical analysis of a shorter temperature history, or
- Figure 14.7.5.2-1.

Table 14.7.5.2-1 gives the minimum elastomer grade to be used in each zone. A grade suitable for a lower-temperature may be specified by the Engineer, but improvements in low-temperature performance can often be obtained only at the cost of reductions in other properties. This low-temperature classification is intended to limit the force on the bridge substructure to 1.5 times the service limit state design force under extreme environmental conditions.

friction sliding surface, in which case the components of the bridge shall be designed to resist four times the design shear force as specified in Article 14.6.3.1.

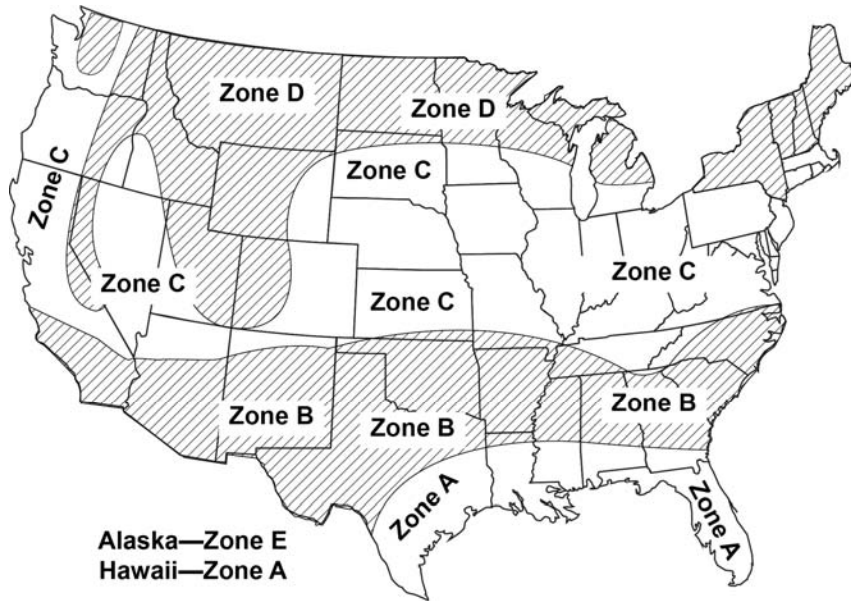

Figure 14.7.5.2-1—Temperature Zones

Table 14.7.5.2-1—Low-Temperature Zones and Minimum Grades of Elastomer

Low-Temperature Zone	A	B	C	D	E
50-yr low temperature (°F)	0	-20	-30	-45	<-45
Maximum number of consecutive days when the temperature does not rise above 32°F	3	7	14	N/A	N/A
Minimum low-temperature elastomer grade	0	2	3	4	5
Minimum low-temperature elastomer grade when special force provisions are incorporated	0	0	2	3	5

14.7.5.3—Design Requirements

14.7.5.3.1—Scope

Bearings designed by the provisions herein shall be tested in accordance with the requirements for steel-reinforced elastomeric bearings as specified in Article 18.2 of the *AASHTO LRFD Bridge Construction Specifications* and the *AASHTO M 251*.

14.7.5.3.2—Shear Deformations

The maximum horizontal displacement of the bridge superstructure, Δ_O , shall be taken as 65 percent of the design thermal movement range, Δ_T , computed in accordance with Article 3.12.2, combined with movements caused by creep, shrinkage, and post-tensioning.

The maximum shear deformation of the bearing, at the service limit state, Δ_S , shall be taken as Δ_O , modified to account for the substructure stiffness and construction procedures. If a low friction sliding surface is installed, Δ_S

C14.7.5.3.1

Steel-reinforced bearings are designed to resist relatively high stresses. Their integrity depends on good quality control during manufacture, which can only be ensured by rigorous testing.

C14.7.5.3.2

The shear deformation is limited to $\pm 0.5 h_r$ in order to avoid rollover at the edges and delamination due to fatigue.

Generally, the installation temperature is within ± 15 percent of the average of the maximum and minimum design temperatures. Consequently, 65 percent of the thermal movement range is used for design purposes (Roeder, 2002). The forgiving nature of elastomeric bearings more than accounts for actual installation temperatures greater than or less than the likely approximated installation

need not be taken to be larger than the deformation corresponding to first slip.

The bearing shall satisfy:

$$h_{rt} \geq 2\Delta_S \quad (14.7.5.3.2-1)$$

where:

h_{rt} = total elastomer thickness (in.)

Δ_S = maximum total shear deformation of the elastomer from applicable service load combinations in Table 3.4.1-1 (in.)

temperature. Additionally, if the bearing is originally set or reset at the average of the design temperature range, 50 percent of the design thermal movement range computed in accordance with Article 3.12.2 may be substituted for 65 percent as specified.

Fatigue tests that formed the basis for this provision were conducted to 20,000 cycles, which represents one expansion/contraction cycle per day for approximately 55 yr (Roeder et al., 1990). The provisions will, therefore, be unconservative if the shear deformation is caused by high-cycle loading due to braking forces or vibration. The maximum shear deformation due to these high-cycle loadings should be restricted to no more than $\pm 0.10 h_{rt}$, unless better information is available. At this strain amplitude, the experiments showed that the bearing has an essentially infinite fatigue life.

If the bridge girders are lifted to allow the bearings to realign after some of the girder shortening has occurred, that may be accounted for in design.

Pier deflections sometimes accommodate a significant portion of the bridge movement, and this may reduce the movement that must be accommodated by the bearing. Construction methods may increase the bearing movement because of poor installation tolerances or poor timing of the bearing installation.

14.7.5.3.3—Combined Compression, Rotation, and Shear

Combinations of axial load, rotation, and shear at the service limit state shall satisfy:

$$\left(\gamma_{a,st} + \gamma_{r,st} + \gamma_{s,st}\right) + 1.75\left(\gamma_{a,cy} + \gamma_{r,cy} + \gamma_{s,cy}\right) \leq 5.0 \quad (14.7.5.3.3-1)$$

The static component of γ_a shall also satisfy:

$$\gamma_{a,st} \leq 3.0 \quad (14.7.5.3.3-2)$$

where:

γ_a = shear strain caused by axial load

γ_r = shear strain caused by rotation

γ_s = shear strain caused by shear displacement

Subscripts “st” and “cy” indicate static and cyclic loading, respectively. Cyclic loading shall consist of loads induced by traffic. All other loads may be considered static. In rectangular bearings, the shear strains shall be evaluated for rotation about the axis which is parallel to the transverse axis of the bridge. Evaluation of shear strains for rotation about the axis which is parallel to the longitudinal axis of the bridge should also be considered. For circular bearings, the rotations about two primary

C14.7.5.3.3

Elastomers are almost incompressible, so when a steel-laminated bearing is loaded in compression, the elastomer expands laterally due to the Poisson effect. That expansion is partially restrained by the steel plates to which the elastomer layers are bonded, and the restraint results in bulging of the layers between the plates. The bulging creates shear stresses at the bonded interface between the elastomer and steel. If they become large enough, they can cause shear failure of the bond or the elastomer adjacent to it. This is the most common form of damage in steel-laminated elastomeric bearings and is the reason why limitations on the shear strain in the elastomer dominate the design requirements.

The cyclic components of the loading are multiplied by an amplification factor of 1.75 in Eq. 14.7.5.3.3-1. This reflects the results of tests that showed that cyclic shear strain causes more debonding damage than a static shear strain of the same amplitude. This approach of using an explicit summation of the shear strain components coupled with an amplification factor on cyclic components is found in other specifications, such as the European EN 1337.

In some cases, the rotations due to dead and live load will have opposite signs, in which case use of the amplification factor of 1.75 could lead to an amplified rotation that is artificially low. This is clearly not consistent with the intent of the amplification factor. In cases where the sense of the loading components in the critical combination is unclear, the sum of the absolute value should be used.

orthogonal axes shall be added vectorially, and the shear strains shall be evaluated using the largest sum.

The shear strains γ_a , γ_r , and γ_s , shall be established by rational analysis, in lieu of which the following approximations are acceptable.

The shear strain due to axial load may be taken as:

$$\gamma_a = D_a \frac{\sigma_s}{GS_i} \quad (14.7.5.3.3-3)$$

in which, for a rectangular bearing:

$$D_a = 1.4 \quad (14.7.5.3.3-4)$$

and, for a circular bearing:

$$D_a = 1.0 \quad (14.7.5.3.3-5)$$

where:

D_a = dimensionless coefficient used to determine shear strain due to axial load

G = shear modulus of the elastomer (ksi)

S_i = shape factor of the i th internal layer of an elastomeric bearing

σ_s = average compressive stress due to total static or cyclic load from applicable service load combinations in Table 3.4.1-1 (ksi)

The shear strain due to rotation for a rectangular bearing may be taken as:

$$\gamma_r = D_r \left(\frac{L}{h_{ri}} \right)^2 \frac{\theta_s}{n} \quad (14.7.5.3.3-6)$$

in which:

$$D_r = 0.5 \quad (14.7.5.3.3-7)$$

and, for a circular bearing:

$$\gamma_r = D_r \left(\frac{D}{h_{ri}} \right)^2 \frac{\theta_s}{n} \quad (14.7.5.3.3-8)$$

in which:

$$D_r = 0.375 \quad (14.7.5.3.3-9)$$

For rectangular bearings, separate evaluations about each primary rotation axis (parallel to the transverse global axis and parallel to the longitudinal global axis of the bridge) may be necessary and appropriate, such as for structures with significant skew. Where rectangular bearings are evaluated about an axis parallel to the global longitudinal axis of the bridge, the definitions of L and W should be interchanged.

For highly skewed or curved bridges, the girder ends will significantly rotate in both bending and torsion. Circular bearings offer a good alternative.

The constants 1.4 assigned to D_a and 0.5 assigned to D_r for rectangular bearings represent simplified values for determining shear strains which are evaluated for rotation about an axis which is parallel to the transverse axis of the bridge. They were derived from procedures suggested by Stanton et al. (2007). D_a and D_r may alternatively be determined with Eqs. C14.7.5.3.3-1 through C14.7.5.3.3-6 about either primary orthogonal axis for rectangular bearings.

$$D_a = \max \left[d_{a1}, \left(d_{a2} + d_{a3} \times \frac{L}{W} \right) \right] \quad (C14.7.5.3.3-1)$$

$$D_r = \frac{1.552 - 0.627\lambda}{2.233 + 0.156\lambda + \frac{L}{W}} \leq 0.5 \quad (C14.7.5.3.3-2)$$

in which:

$$d_{a1} = 1.06 + 0.210\lambda + 0.413\lambda^2 \quad (C14.7.5.3.3-3)$$

$$d_{a2} = 1.506 - 0.071\lambda + 0.406\lambda^2 \quad (C14.7.5.3.3-4)$$

$$d_{a3} = -0.315 + 0.195\lambda - 0.047\lambda^2 \quad (C14.7.5.3.3-5)$$

$$\lambda = S_i \sqrt{\frac{3G}{K}} \quad (C14.7.5.3.3-6)$$

where:

K = bulk modulus (ksi)

L = plan dimension of the bearing perpendicular to the axis of rotation under consideration (generally parallel to the global longitudinal bridge axis) (in.)

W = plan dimension of the bearing parallel to the axis of rotation under consideration (generally parallel to the global transverse bridge axis) (in.)

λ = compressibility index

where:

- D = diameter of the bearing (in.)
- D_r = dimensionless coefficient used to determine shear strain due to rotation
- h_{ri} = thickness of i th internal elastomeric layer (in.)
- L = plan dimension of the bearing perpendicular to the axis of rotation under consideration (generally parallel to the global longitudinal bridge axis) (in.)
- n = number of interior layers of elastomer, where interior layers are defined as those layers which are bonded on each face. Exterior layers are defined as those layers which are bonded only on one face. When the thickness of the exterior layer of elastomer is equal to or greater than one-half the thickness of an interior layer, the parameter, n , may be increased by one-half for each such exterior layer.
- θ_s = maximum static or cyclic service limit state design rotation angle of the elastomer specified in Article 14.4.2.1 (rad.)

The shear strain due to shear deformation of any bearing may be taken as:

$$\gamma_s = \frac{\Delta_s}{h_{rt}} \quad (14.7.5.3.3-10)$$

where:

- h_{rt} = total elastomer thickness (in.)
- Δ_s = maximum total static or cyclic shear deformation of the elastomer from applicable service load combinations in Table 3.4.1-1 (in.)

In each case, the static and cyclic components of the shear strain shall be considered separately and then combined using Eq. 14.7.5.3.3-1.

In bearings with externally bonded steel plates on both top and bottom, the peak hydrostatic stress shall satisfy:

$$\sigma_{hyd} \leq 2.25G \quad (14.7.5.3.3-11)$$

in which:

$$\sigma_{hyd} = 3GS_i^3 \frac{\theta_s}{n} C_\alpha \quad (14.7.5.3.3-12)$$

In the absence of better information, the bulk modulus, K , may be taken as 450 ksi for all elastomers permissible under this specification for use in steel-reinforced elastomeric bearings.

The compressibility index, λ , represents the effect of finite bulk stiffness of the rubber. For conventional bearings it makes little difference, but in high shape factor bearings it reduces the stiffness below the value that would be computed using an incompressible model (i.e. with $\lambda = 0$).

Previous editions of these Specifications contained provisions to prevent net upward movement of any point on the bearing. Recent research (Stanton et al., 2007) has shown that, if the bearing is not equipped with bonded external plates, the sole plate can lift away from the bearing without causing any tension in the elastomer. Furthermore, the compression effects are slightly less severe than in a bearing that is identical except for the presence of bonded external plates, and is subjected to the same loading combination. Thus the “no-lift-off” provisions have been removed.

$$C_\alpha = \frac{4}{3} \left[\left(\alpha^2 + \frac{1}{3} \right)^{1.5} - \alpha(1 - \alpha^2) \right] \quad (14.7.5.3.3-13)$$

$$\alpha = \frac{\varepsilon_a}{S_i} \frac{n}{\theta_s} \quad (14.7.5.3.3-14)$$

$$\varepsilon_a = \frac{\sigma_s}{3B_a G S_i^2} \quad (14.7.5.3.3-15)$$

for rectangular bearings:

$$B_a = 1.6 \quad (14.7.5.3.3-16)$$

and, for circular bearings:

$$B_a = 1.6 \quad (14.7.5.3.3-17)$$

where:

B_a = dimensionless coefficient used to determine peak hydrostatic stress

ε_a = total of static and cyclic average axial strain taken as positive for compression in which the cyclic component is multiplied by 1.75 from applicable service load combinations in Table 3.4.1-1 (ksi)

θ_s = total of static and cyclic maximum service limit state design rotation angles of the elastomer specified in Article 14.4.2.1 in which the cyclic component is multiplied by 1.75 (rad.)

σ_s = total of static and cyclic average compressive stress in which the cyclic component is multiplied by 1.75 from applicable service load combinations in Table 3.4.1-1 (ksi)

For values of α greater than one third, the hydrostatic stress is compressive, so Eq. 14.7.5.3.3-11 is satisfied automatically and no further evaluation is necessary.

14.7.5.3.4—Stability of Elastomeric Bearings

Bearings shall be investigated for instability at the service limit state load combinations specified in Table 3.4.1-1.

Bearings satisfying Eq. 14.7.5.3.4-1 shall be considered stable, and no further investigation of stability is required.

$$2A \leq B \quad (14.7.5.3.4-1)$$

in which:

However, in a bearing equipped with external plates, upward movement of part of the plate can cause internal rupture due to hydrostatic tension. Provisions have been added to address this case. It is expected to control only rarely, and when it does, it is likely to do so during construction, when the axial load is light and the rotation, due to pre-camber, is large. For the construction load case, the cyclic components of the loading will be zero. For bearings with external plates, Eqs. 14.7.5.3.3-1 and 14.7.5.3.3-11 should be checked under all critical loading conditions, including construction, and about both strong and weak axes of rectangular bearings when necessary and appropriate.

The constant 1.6 assigned to B_a for rectangular and circular bearings represents a simplified value for determining compressive strain due to a purely axial load (Eq. 14.7.5.3.3-15). This also applies to hydrostatic tension which is evaluated for rotation about an axis, which is parallel to the transverse axis of the bridge. It was derived from procedures suggested by Stanton et al. (2007). A more precise value of B_a (and consequently more precise value of E and axial strain) may alternatively be determined with Eqs. C14.7.5.3.3-7 or C14.7.5.3.3-8 about either primary orthogonal axis.

For rectangular bearings:

$$B_a = (2.31 - 1.86\lambda) + (-0.90 + 0.96\lambda) \times \left[1 - \min\left(\frac{L}{W}, \frac{W}{L}\right) \right]^2 \quad (C14.7.5.3.3-7)$$

and, for circular bearings:

$$B_a = \frac{2}{1 + 2\lambda^2} \quad (C14.7.5.3.3-8)$$

Tests have shown that sharp edges on the internal steel reinforcement layers cause stress concentrations in the elastomer and promote the onset of debonding. The internal steel reinforcement layers should be deburred or otherwise rounded prior to molding the bearing. The design values in Eq. 14.7.5.3.3-1 are consistent with this procedure.

C14.7.5.3.4

The average compressive stress is limited to half the predicted buckling stress. The latter is calculated using the buckling theory developed by Gent, modified to account for changes in geometry during compression, and calibrated against experimental results (Gent, 1964; Stanton et al., 1990). This provision will permit taller bearings and reduced shear forces compared to those permitted under previous editions of the AASHTO Standard Specifications.

$$A = \frac{1.92 \frac{h_{rt}}{L}}{\sqrt{1 + \frac{2.0L}{W}}} \quad (14.7.5.3.4-2)$$

$$B = \frac{2.67}{(S_i + 2.0) \left(1 + \frac{L}{4.0W}\right)} \quad (14.7.5.3.4-3)$$

where:

G = shear modulus of the elastomer (ksi)

h_{rt} = total elastomer thickness (in.)

L = plan dimension of the bearing perpendicular to the axis of rotation under consideration (generally parallel to the global longitudinal bridge axis) (in.)

S_i = shape factor of the i th internal layer of an elastomeric bearing

W = plan dimension of the bearing parallel to the axis of rotation under consideration (generally parallel to the global transverse bridge axis) (in.)

For a rectangular bearing where L is greater than W , stability shall be investigated by interchanging L and W in Eqs. 14.7.5.3.4-2 and 14.7.5.3.4-3.

For circular bearings, stability may be investigated by using the equations for a square bearing with $W = L = 0.8D$.

For rectangular bearings not satisfying Eq. 14.7.5.3.4-1, the stress due to the total load shall satisfy Eq. 14.7.5.3.4-4 or 14.7.5.3.4-5.

- If the bridge deck is free to translate horizontally:

$$\sigma_s \leq \frac{GS_i}{2A - B} \quad (14.7.5.3.4-4)$$

- If the bridge deck is fixed against horizontal translation:

$$\sigma_s \leq \frac{GS_i}{A - B} \quad (14.7.5.3.4-5)$$

14.7.5.3.5—Reinforcement

The minimum thickness of steel reinforcement, h_s , shall be .0625 in., as specified in Article 4.5 of AASHTO M 251.

The thickness of the steel reinforcement, h_s , shall satisfy:

Eq. 14.7.5.3.4-4 corresponds to buckling in a sideway mode and is relevant for bridges in which the deck is not rigidly fixed against horizontal translation at any point. This may be the case in many bridges for transverse translation perpendicular to the longitudinal axis. If one point on the bridge is fixed against horizontal movement, the sideway buckling mode is not possible, and Eq. 14.7.5.3.4-5 should be used. This freedom to move horizontally should be distinguished from the question of whether the bearing is subject to shear deformations relevant to Articles 14.7.5.3.2 and 14.7.5.3.3. In a bridge that is fixed at one end, the bearings at the other end will be subjected to imposed shear deformation but will not be free to translate in the sense relevant to buckling due to the restraint at the opposite end of the bridge.

A negative or infinite limit from Eq. 14.7.5.3.4-5 indicates that the bearing is stable and is not dependent on σ_s .

If the value $A - B \leq 0$, the bearing is stable and is not dependent on σ_s .

C14.7.5.3.5

The reinforcement should sustain the tensile stresses induced by compression of the bearing. With the present load limitations, the minimum steel plate thickness practical for fabrication will usually provide adequate strength.

- At the service limit state:

$$h_s \geq \frac{3h_{ri}\sigma_s}{F_y} \quad (14.7.5.3.5-1)$$

- At the fatigue limit state:

$$h_s \geq \frac{2h_{ri}\sigma_L}{\Delta F_{TH}} \quad (14.7.5.3.5-2)$$

where:

ΔF_{TH} = constant amplitude fatigue threshold for Category A as specified in Article 6.6 (ksi)

h_{ri} = thickness of i th internal elastomeric layer (in.)

σ_L = average compressive stress at the service limit state (load factor = 1.0) due to live load (ksi)

σ_s = average compressive stress due to total load from applicable service load combinations in Table 3.4.1-1 (ksi)

F_y = yield strength of steel reinforcement (ksi)

If holes exist in the reinforcement, the minimum thickness shall be increased by a factor equal to twice the gross width divided by the net width.

Holes in the reinforcement cause stress concentrations. Their use should be discouraged. The required increase in steel thickness accounts for both the material removed and the stress concentrations around the hole.

14.7.5.3.6—Compressive Deflection

Deflections of elastomeric bearings due to dead load and to instantaneous live load alone shall be considered separately.

Loadings considered in this Article shall be at the service limit state with all load factors equal to 1.0.

Instantaneous live load deflection shall be taken as:

$$\delta_L = \sum \varepsilon_{Li} h_{ri} \quad (14.7.5.3.6-1)$$

where:

ε_{Li} = instantaneous live load compressive strain in i th elastomer layer

h_{ri} = thickness of i th elastomeric layer (in.)

Initial dead load deflection shall be taken as:

$$\delta_d = \sum \varepsilon_{di} h_{ri} \quad (14.7.5.3.6-2)$$

where:

ε_{di} = initial dead load compressive strain in i th elastomer layer

C14.7.5.3.6

Limiting instantaneous live load deflections is important to ensure that deck joints and seals are not damaged. Furthermore, bearings that are too flexible in compression could cause a small step in the road surface at a deck joint when traffic passes from one girder to the other, giving rise to additional impact loading. A maximum relative live load deflection across a joint of 0.125 in. is suggested. Joints and seals that are sensitive to relative deflections may require limits that are tighter than this.

Long-term dead load deflections should be considered where joints and seals between sections of the bridge rest on bearings of different design and when estimating redistribution of forces in continuous bridges caused by settlement.

Laminated elastomeric bearings have a nonlinear load deflection curve in compression. In the absence of information specific to the particular elastomer to be used, Eq. C14.7.5.3.6-1 or Figure C14.7.6.3.3-1 may be used as an approximate guide for calculating dead and live load compressive strains for Eqs. 14.7.5.3.6-1 and 14.7.5.3.6-2.

It should be noted that as shape factors become higher (greater than ≈ 6), the correlation of results between Eq. C14.7.5.3.6-1 and Figure C14.7.6.3.3-1 diverges.

h_{ri} = thickness of i th elastomeric layer (in.)

Long-term dead load deflection, including the effects of creep, shall be taken as:

$$\delta_{lt} = \delta_d + a_{cr}\delta_d \quad (14.7.5.3.6-3)$$

where:

a_{cr} = creep deflection divided by initial dead load deflection

Values for ϵ_{Li} and ϵ_{di} shall be determined from test results or by analysis. Creep effects should be determined from information relevant to the elastomeric compound used. If the engineer does not elect to obtain a value for the ratio, a_{cr} , from test results using Annex A2 of AASHTO M 251, the values given in Table 14.7.6.2-1 may be used.

Eq. C14.7.5.3.6-1 provides a linear solution for a material that exhibits nonlinear behavior in compression. A bearing-specific value of axial strain may be found using Eqs. 14.7.5.3.3-15, C14.7.5.3.3-7 and C14.7.5.3.3-8.

$$\epsilon = \frac{\sigma}{4.8GS^2} \quad (C14.7.5.3.6-1)$$

where:

σ = instantaneous live load compressive stress or dead load compressive stress in an individual elastomer layer (ksi)

S = shape factor of an individual elastomer layer

G = shear modulus of the elastomer (ksi)

Eq. C14.7.5.3.6-1 or Figure C14.7.6.3.3-1 may also be used as an approximate guide for specifying an allowable value of compressive strain at the design dead plus live service limit state compressive load when employing Section 8.8.1 of AASHTO M 251.

Guidance for specifying an allowable value for creep when Annex A2 of AASHTO M 251 is employed may be obtained from NCHRP Report 449 or from Table 14.7.6.2-1

Reliable test data on total deflections are rare because of the difficulties in defining the baseline for deflection. However, the change in deflection due to live load can be reliably predicted either by design aids based on test results or by using theoretically based equations (Stanton and Roeder, 1982). In the latter case, it is important to include the effects of bulk compressibility of the elastomer, especially for high-shape factor bearings.

14.7.5.3.7—Seismic and Other Extreme Event Provisions

Elastomeric expansion bearings shall be provided with adequate seismic and other extreme event resistant anchorage to resist the horizontal forces in excess of those accommodated by shear in the pad unless the bearing is intended to act as a fuse or irreparable damage is permitted. The sole plate and the base plate shall be made wider to accommodate the anchor bolts. Inserts through the elastomer should not be allowed, unless approved by the Engineer. The anchor bolts shall be designed for the combined effect of bending and shear for seismic and other extreme event loads as specified in Article 14.6.5.3. Elastomeric fixed bearings shall be provided with horizontal restraint adequate for the full horizontal load.

C14.7.5.3.7

The seismic and other extreme event demands on elastomeric bearings exceed their design limits. Therefore, positive connection between the girder and the substructure concrete is needed. If the bearing is intended to act as a fuse or irreparable damage is permitted, the positive connection need not be designed for the maximum extreme event limit state forces.

Holes in elastomer cause stress concentrations that can lead to tearing of the elastomer during earthquakes.

14.7.5.4—Anchorage for Bearings without Bonded External Plates

In bearings without externally bonded steel plates, a restraint system shall be used to secure the bearing against horizontal movement if:

$$\frac{\theta_s}{n} \geq \frac{3\epsilon_a}{S_i} \quad (14.7.5.4-1)$$

where:

n = number of interior layers of elastomer, where interior layers are defined as those layers which are bonded on each face. Exterior layers are defined as those layers which are bonded only on one face. When the thickness of the exterior layer of elastomer is equal to or greater than one-half the thickness of an interior layer, the parameter, n , may be increased by one-half for each such exterior layer.

S_i = shape factor of the i th internal layer of an elastomeric bearing

ϵ_a = total of static and cyclic average axial strain taken as positive for compression in which the cyclic component is multiplied by 1.75 from applicable service load combinations in Table 3.4.1-1 (ksi)

θ_s = total of static and cyclic maximum service limit state design rotation angles of the elastomer specified in Article 14.4.2.1 in which the cyclic component is multiplied by 1.75 (rad.)

14.7.6—Elastomeric Pads and Steel-Reinforced Elastomeric Bearings—Method A

14.7.6.1—General

The provisions of this Article shall be taken to apply to the design of:

- Plain elastomeric pads, PEP;
- Pads reinforced with discrete layers of fiberglass, FGP;
- Steel-reinforced elastomeric bearings in which $S_i^2/n < 22$, and for which the primary rotation is about the axis parallel to the transverse axis of the bridge; and
- Cotton-duck pads (CDP) with closely spaced layers of cotton duck and manufactured and tested under compression in accordance with Military Specification MIL-C-882E except where superseded by these Specifications.

C14.7.6.1

Elastomeric pads have characteristics different from those of steel-reinforced elastomeric bearings. Plain elastomeric pads are weaker and more flexible because they are restrained from bulging by friction alone (Roeder and Stanton, 1986, 1983). Slip inevitably occurs, especially under dynamic loads, causing larger compressive deflections and higher internal strains in the elastomer.

In the fourth edition of the Specifications, the stress limits for steel elastomeric bearing pads designed by Method A were increased by 25 percent. This increase was based on the application of Method B equations with an assumed service limit rotation of 0.02 radians to determine the strain effects of rotation and the resulting reserve capacity for axial stresses (Stanton et al., 2007). Therefore, design for rotation in Method A is implicit in the geometric and stress limits given. Since Method A is restricted to

where:

n = number of interior layers of elastomer, where interior layers are defined as those layers which are bonded on each face. Exterior layers are defined as those layers which are bonded only on one face. When the thickness of the exterior layer of elastomer is equal to or greater than one-half the thickness of an interior layer, the parameter, n , may be increased by one-half for each such exterior layer.

S_i = shape factor of the i th internal layer of an elastomeric bearing

Layer thicknesses in FGP may be different from one another. For steel-reinforced elastomeric bearings designed in accordance with the provisions of this Section, internal layers shall be of the same thickness, and cover layers shall be no more than 70 percent of the thickness of internal layers.

The shape factor for PEP, FGP pads and steel-reinforced elastomeric bearings covered by this Article shall be determined as specified in Article 14.7.5.1. The shape factor for CDP shall be based upon the total pad thickness.

bearings pads rotated about their strong axis, a square bearing pad provided the conservative case for determining the increased stress limit. A S_i^2/n ratio of 16 was selected for the calculation and resulted in the compressive stress limits of Eqs. 14.7.6.3.2–6 and 14.7.6.3.2–7. For rectangular bearing pads, the specified limit of 22 for S_i^2/n is appropriate except that a limiting value of 20 for S_i^2/n should be considered when the value of n is greater than or equal to 3. A limiting value of 16 should be considered when the bearing pad is circular or nearly square.

In pads reinforced with layers of fiberglass, the reinforcement inhibits the deformations found in plain pads. However, elastomers bond less well to fiberglass, and the fiberglass is weaker than steel, so the fiberglass pad is unable to carry the same loads as a steel-reinforced bearing (Crozier et al., 1979). FGP has the advantage that it can be cut to size from a large sheet of vulcanized material.

CDP are preformed pads that are produced in large sheets and cut to size for specific bridge applications. CDP are reinforced with closely spaced layers of cotton-duck and typically display high compressive stiffness and strength, obtained by the use of very thin elastomeric layers. However, the thin layers also give rise to very high shear and rotational stiffness, which could easily lead to edge loading and a higher shear stiffness than that to be found in layered bearings. These increased shear and rotational stiffnesses lead to larger moments and forces in the bridge and reduced movement and rotational capacity of the bearing pad. As a consequence, CDP is often used with a PTFE slider on top of the elastomer pad (Nordlin et al., 1970).

It is essential that CDP bearing pads be tested and verified to meet the test requirements of Military Specification MIL-C-882E which can be found at: <http://assist.daps.dla.mil>. Note that there is no AASHTO equivalent to this Military Specification. A summary of testing and acceptance criteria for CDP is given below.

These criteria require that:

- A lot of preformed CDP be defined as a single sheet that is continuously formed to a given thickness except that a single lot not exceed 2500 lbs of material;
- A minimum of two samples from each lot shall be tested;
- The samples be 2 in. × 2 in. with the full sheet thickness;
- The test specimens be cured for four hours at room temperature (70°F ± 10°F);
- Each specimen is then to be loaded in compression, perpendicular to the direction of lamination;
- The origin of deflection and compressive strain measurements be taken at a compressive stress of 5 psi;

- The load be increased at a steady rate of 500 lbs/ min. and the deflection be recorded;
- The specimen be loaded to a compressive stress of 10,000 psi without fracture or other failure; and
- The entire lot of CDP be rejected if any of the CDP specimens fail to satisfy either of these test criteria: The average compressive strain of the specimens for that lot is not to be less than 0.075 in./in. nor shall it be greater than 0.175 in./in. at an average compressive stress of 2,000 psi. CDP bearing pads which fail to achieve the 10,000 psi stress limit here fall outside the specified strain range and will not develop the deformation limits permitted in later parts of Article 14.7.

14.7.6.2—Material Properties

The elastomeric-type materials for PEP, FGP, and steel reinforced elastomeric bearings shall satisfy the requirements of Article 14.7.5.2, except as noted below:

- Hardness on the Shore A scale may be used as a basis for specification of bearing material,
- The specified shear modulus for PEP, FGP, and steel-reinforced elastomeric bearings with a PTFE or equivalent slider on top of the bearing shall be between 0.080 ksi and 0.250 ksi or the nominal hardness shall be between 50 and 70 on the Shore A scale, and
- The specified shear modulus for steel-reinforced elastomeric bearings without a PTFE or equivalent slider on top of the bearing designed in accordance with the provisions of Article 14.7.6 shall be between 0.080 and 0.175 ksi or the nominal hardness shall be between 50 and 60 on the Shore A scale.

PEP, FGP, and steel reinforced elastomeric bearings with or without a PTFE or equivalent slider on top of the bearing shall conform to the requirements of Article 18.2 of the *AASHTO LRFD Bridge Construction Specifications* and AASHTO M 251. If the material is specified by its hardness, the shear modulus for design purposes shall be taken as the least favorable value from the range for that hardness given in Table 14.7.6.2-1. Intermediate values may be obtained by interpolation. If the material is specified by shear modulus, it shall be taken for design purposes as the least favorable from the value specified according to the ranges given in Article 14.7.5.2. Other properties, such as creep deflection, are also given in Table 14.7.6.2-1.

The shear force on the structure induced by deformation of the elastomer in PEP, FGP and steel-reinforced elastomeric bearings shall be based on a G value not less than that of the elastomer at 73°F. Effects of relaxation shall be ignored.

C14.7.6.2

The elastomer requirements for PEP and FGP are the same as those required for steel-reinforced elastomeric bearings. The ranges given in Table 14.7.6.2-1 represent the variations found in practice. If the material is specified by hardness, a safe and presumably different estimate of G should be taken for each of the design calculations, depending on whether the parameter being calculated is conservatively estimated by over- or under-estimating the shear modulus. Creep varies from one compound to another and is generally more prevalent in harder elastomers or those with a higher shear modulus but is seldom a problem if high-quality materials are used. This is particularly true because the deflection limits are based on serviceability and are likely to be controlled by live load, rather than total load. The creep values given in Table 14.7.6.2-1 are representative of neoprene and are conservative for natural rubber.

CDP shall be manufactured to Military Standards MIL-C-882E except where the provisions of these Specifications supersede those provisions. The elastomeric-type materials for CDP shall have a nominal hardness between 50 and 70 on the Shore A scale and meet the requirements of Article 14.7.5.2 as appropriate. The finished CDP shall have a nominal hardness between 85 and 95 on the Shore A scale. The shear modulus for CDP may be estimated using Eq. 14.7.6.3.4-3. The cotton-duck reinforcement shall be either a two-ply cotton yarn or a single-ply 50-50 blend cotton-polyester. The fabric shall have a minimum tensile strength of 150 lb./in. width when tested by the grab method. The fill shall be 40 ± 2 threads per in., and the warp shall be 50 ± 1 threads per in. The CDP provisions included herein shall be taken as only applicable to bearing pads up to 2 in. in total thickness.

CDP is made of elastomers with hardness and properties similar to that used for PEP and FGP. However, the closely spaced layers of duck fabric reduce the indentation and increase the hardness of the finished pad to the 85 to 95 durometer range. Appendix X1 of AASHTO M 251 contains provisions for hardness of elastomers, but not finished CDP. The acceptable range from the specified value for hardness of elastomers is ± 5 points on the Shore A scale. The acceptable range criteria for elastomers in AASHTO M 251 may also be considered for finished CDP. The cotton-duck requirements are restated from the military specification because the reinforcement is essential to the good performance of these pads.

Table 14.7.6.2-1—Correlated Material Properties

	Hardness (Shore A)		
	50	60	70 ¹
Shear Modulus @ 73°F (ksi)	0.095–0.130	0.130–0.200	0.200–0.300
Creep deflection @ 25 yr divided by initial deflection	0.25	0.35	0.45

¹ Only for PEP, FGP, and steel-reinforced elastomeric bearings with a PTFE or equivalent slider on top of the bearing.

14.7.6.3—Design Requirements

14.7.6.3.1—Scope

Steel-reinforced elastomeric bearings may be designed in accordance with this Article, in which case they qualify for the test requirements appropriate for elastomeric pads. For this purpose, they shall be treated as FGP.

The provisions for FGP apply only to pads where the fiberglass is placed in double layers 0.125 in. apart.

The physical properties of neoprene and natural rubber used in these bearings shall conform to AASHTO M 251.

C14.7.6.3.1

The design methods for elastomeric pads are simpler and more conservative than those for steel-reinforced bearings, so the test methods are less stringent than those of Article 14.7.5. Steel-reinforced elastomeric bearings may be made eligible for these less stringent testing procedures by limiting the compressive stress as specified in Article 14.7.6.3.2.

The three types of pad, PEP, FGP, and CDP behave differently, so information relevant to the particular type of pad should be used for design. For example, in PEP, slip at the interface between the elastomer and the material on which it is seated or loaded is dependent on the friction coefficient, and this will be different for pads seated on concrete, steel, grout, epoxy, etc.

14.7.6.3.2—Compressive Stress

At the service limit state, the average compressive stresses, σ_s and σ_L , in any layer shall satisfy:

- For PEP:

$$\sigma_s \leq 1.00GS \quad \text{and} \quad (14.7.6.3.2-1)$$

$$\sigma_s \leq 0.80 \text{ ksi} \quad (14.7.6.3.2-2)$$

C14.7.6.3.2

In PEP, the compressive stress is limited to G times the shape factor and an absolute limit of 0.80 ksi. A stress check incorporating G times the shape factor limits the use of a proportionately thick PEP with a high compressive stress. In FGP, the compressive stress is limited to 1.25G times the effective shape factor and an absolute limit of 1.0 ksi. The CDP stress limits were developed to provide

- For FGP:
 - $\sigma_s \leq 1.25GS_i$ and (14.7.6.3.2-3)
 - $\sigma_s \leq 1.0$ ksi (14.7.6.3.2-4)
- For CDP:
 - $\sigma_s \leq 3.0$ ksi and (14.7.6.3.2-5)
 - $\sigma_L \leq 2.0$ ksi (14.7.6.3.2-6)

where:

σ_s = average compressive stress due to total load from applicable service load combinations in Table 3.4.1-1 (ksi)

S = shape factor for PEP

σ_L = average compressive stress at the service limit state (load factor = 1.0) due to live load (ksi)

In FGP, the value of S_i used shall be based upon an h_{ri} layer thickness which equals the greatest distance between midpoints of two double fiberglass reinforcement layers.

For steel-reinforced elastomeric bearings designed in accordance with the provisions of this Article:

$$\sigma_s \leq 1.25GS_i \text{ and} \quad (14.7.6.3.2-7)$$

$$\sigma_s \leq 1.25 \text{ ksi} \quad (14.7.6.3.2-8)$$

where the value of S_i used shall be that of an internal layer of the bearing.

These stress limits may be increased by ten percent where shear deformation is prevented.

In FGP, the value of S_i used shall be based upon an h_{ri} layer thickness that equals the greatest distance between midpoints of two double fiberglass reinforcement layers.

14.7.6.3.3—Compressive Deflection

In addition to the provisions of Article 14.7.5.3.6, the following shall also apply.

In lieu of using specific product data, the compressive deflection of a FGP should be taken as 1.5 times the deflection estimated for steel-reinforced bearings of the same shape factor in Article 14.7.5.3.6.

The compressive deflection under instantaneous live load and initial dead load of a PEP or an internal layer of a steel-reinforced elastomeric bearing at the service limit state without impact shall not exceed $0.09h_{ri}$, where h_{ri} is the thickness of a PEP, or the thickness of an internal layer of a steel-reinforced elastomeric bearing (in.).

long-term serviceability and durability. CDP stiffness and behavior is less sensitive to shape factor. The total maximum compressive stress is limited to 3.0 ksi because experiments showed that CDP does not fail under monotonically compressive stress values significantly larger than this stress limit. CDP, which is subject to compressive stress levels larger than 3.0 ksi, may delaminate under dynamic loadings typical of those experienced by bridge bearings. CDP may experience dramatic failure when maximum compressive strains exceed approximately 0.25. However, bearing pads which meet the strain and stiffness limits which are required by the military specification will not achieve this failure strain under pure compressive load. The live load stresses are limited to 2.0 ksi, because research shows that delamination is caused by the compressive stress range as well as the maximum compressive level. Live loads control the maximum compressive stress range under repeated loading, and this limit controls the adverse effects of this delamination. Larger compressive strains would result in increased damage to the bridge and the bearing pad and reduced serviceability of the CDP (Lehman et al., 2003).

The reduced stress limit for steel-reinforced elastomeric bearings designed in accordance with these provisions is invoked in order to allow these bearings to be eligible for the less stringent test requirements for elastomeric pads.

C14.7.6.3.3

The compressive deflection with PEP, FGP, and CDP will be larger and more variable than those of steel-reinforced elastomeric bearings. Appropriate data for these pad types may be used to estimate their deflections. In the absence of such data, the compressive deflection of a PEP and FGP may be estimated at 3 and 1.5 times, respectively, the deflection estimated for steel-reinforced bearings of the same shape factor in Article 14.7.5.3.6.

Figure C14.7.6.3.3-1 provides design aids for determining the strain in an elastomer layer for steel reinforced bearings based upon durometer hardness and shape factor. It should also be noted that initial dead load compressive deflection does not include deflections associated with long-term creep.

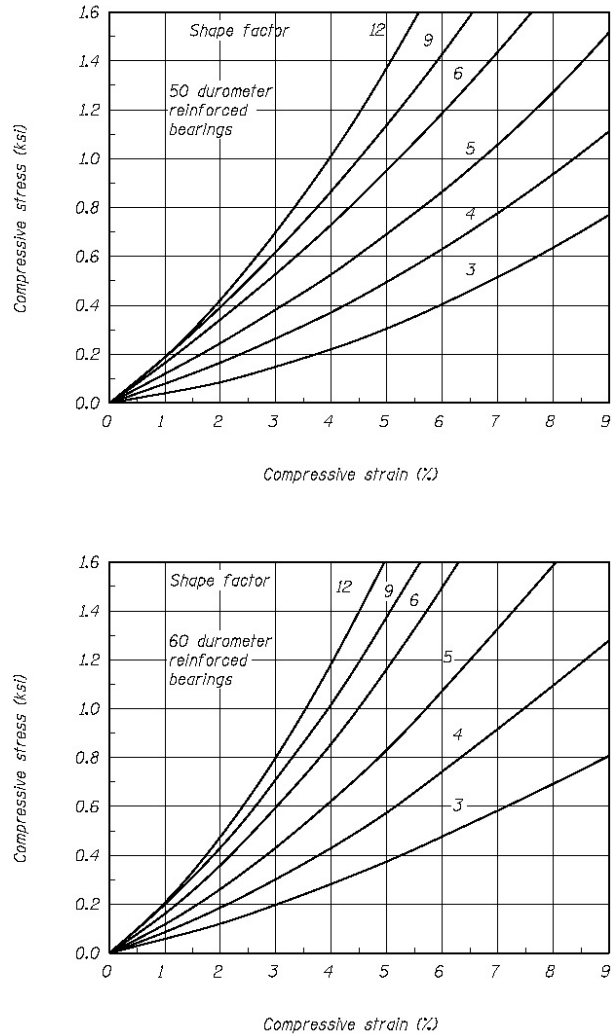

Figure C14.7.6.3.3-1—Stress-Strain Curves

For CDP, the computed compressive strain, ϵ_s , may be taken as:

$$\epsilon_s = \frac{\sigma_s}{E_c} \tag{14.7.6.3.3-1}$$

where:

E_c = uniaxial compressive stiffness of the CDP bearing pad. It may be taken as 30 ksi in lieu of pad-specific test data (ksi)

σ_s = average compressive stress due to total load from applicable service load combinations in Table 3.4.1-1 (ksi)

CDP is typically very stiff in compression. The shape factor may be computed, but it has a different meaning and less significance to the compressive deflection than it does for FGP and PEP (Roeder et al., 2000). As a result, the maximum compressive deflection for CDP can be based upon an average compressive strain, ϵ_s , for the total bearing pad thickness as computed in Eq. 14.7.6.3.3-1.

14.7.6.3.4—Shear

The maximum horizontal superstructure displacement shall be computed in accordance with Article 14.4. The maximum shear deformation of the pad at the service limit state, Δ_S , shall be taken as the maximum horizontal superstructure displacement, reduced to account for the pier flexibility and modified for construction procedures. If a low friction sliding surface is used, Δ_S need not be taken to be larger than the deformation corresponding to first slip.

The provisions of Article 14.7.5.3.2 shall apply, except that the pad shall be designed as follows:

- For PEP, FGP and steel-reinforced elastomeric bearings:

$$h_{rt} \geq 2\Delta_S \quad (14.7.6.3.4-1)$$

- For CDP:

$$h_{rt} \geq 10\Delta_S \quad (14.7.6.3.4-2)$$

where:

h_{rt} = smaller of total elastomer or bearing thickness (in.)

Δ_S = maximum total shear deformation of the bearing from applicable service load combinations in Table 3.4.1-1 (in.)

The shear modulus, G , for CDP for determination of the bearing force in Article 14.6.3.1 may be conservatively estimated as:

$$G = 2\sigma_s \geq 2.0 \text{ ksi} \quad (14.7.6.3.4-3)$$

where:

σ_s = average compressive stress due to total load from applicable service load combinations in Table 3.4.1-1 (ksi)

*14.7.6.3.5—Rotation**14.7.6.3.5a—General*

The provisions of these Articles shall apply at the service limit state. Rotations shall be taken as the maximum sum of the effects of initial lack of parallelism and subsequent girder end rotation due to imposed loads and movements. Stress shall be the maximum stress associated with the load conditions inducing the maximum rotation.

C14.7.6.3.4

The deformation in PEP and FGP are limited to $\pm 0.5 h_{rt}$ because these movements are the maximum tolerable for repeated and long-term strains in the elastomer. These limits are intended to ensure serviceable bearings with no deterioration of performance and they limit the forces that the pad transmits to the structure.

In CDP, the shear deflection is limited to only one-tenth of the total elastomer thickness. There are several reasons for this limitation. First, experiments show that CDP may split and crack at larger shear strains. Second, CDP has much larger shear stiffness than that noted with steel-reinforced elastomeric bearings, PEP and FGP, and so the strain limit assures that CDP pads do not cause dramatically larger bearing forces to the structure than do other bearing systems. Third, the greater shear stiffness means that relative slip between the CDP and the bridge girders is likely if the deformation required of the bearing is too large. Slip may lead to abrasion and deterioration of the pads, as well as other serviceability concerns. Slip may also lead to increased costs because of anchorage and other requirements. Finally, CDP pads are harder than PEP and FGP, and so they are very suitable for the addition of PTFE sliding surfaces to accommodate the required bridge movements. As a result, CDP with large translational movements is invariably designed with PTFE sliding surfaces.

C14.7.6.3.5a

In the fourth edition of the Specifications, rotation of steel-reinforced elastomeric bearings and elastomeric pads was, in part, controlled by preventing uplift between the bearing and the structure. Research (Stanton et al., 2007) has shown that lift-off is not a concern for elastomeric bearings and the “no lift-off” provisions were removed from Method B as described in Article C14.7.5.3.3. Furthermore, as explained in Article C14.7.6.1, design for rotation in Method A is implicit in the geometric and stress limits given. Therefore, the “no lift-off” provisions have been removed from Method A in order to provide consistency between the two procedures. Additionally, it

14.7.6.3.5b—Rotation of CDP

The maximum compressive strain due to combined compression and rotation of CDP at the service limit state, ϵ_t , shall not exceed:

$$\epsilon_t = \epsilon_c + \frac{\theta_s L}{2t_p} < 0.20 \quad (14.7.6.3.5b-1)$$

where:

$$\epsilon_c = \frac{\sigma_s}{E_c} \quad (14.7.6.3.5b-2)$$

Maximum rotation shall be limited to:

$$\theta_s \leq 0.80 \frac{2t_p \epsilon_c}{L} \text{ and} \quad (14.7.6.3.5b-3)$$

$$\theta_L \leq 0.20 \frac{2t_p \epsilon_c}{L} \quad (14.7.6.3.5b-4)$$

where:

E_c = uniaxial compressive stiffness of the CDP bearing pad. It may be taken as 30 ksi in lieu of pad-specific test data

L = length of a CDP bearing pad in the plane of rotation (in.)

t_p = total thickness of CDP pad (in.)

ϵ_c = maximum uniaxial strain due to compression under total load from applicable service load combinations in Table 3.4.1-1

ϵ_t = maximum uniaxial strain due to combined compression and rotation from applicable service load combinations in Table 3.4.1-1

σ_s = average compressive stress due to total load associated with the maximum rotation from applicable service load combinations in Table 3.4.1-1 (ksi)

θ_L = maximum rotation of the CDP pad at the service limit state (load factor = 1.0) due to live load (rad.)

has been shown that the Method A limit on S_i^2/n (Article 14.7.6.1) prevents the build-up of any significant hydrostatic tension in bearings with bonded external plates.

C14.7.6.3.5b

Rotation, and combined compression and rotation of CDP are controlled by shear strain limits and delamination requirements. Experiments show that CDP that meets the testing requirements of MIL-C-882E will not fracture or fail until a combined compressive strain exceeds 0.25. Creep strains do not contribute to this fracture potential. Design Eq. 14.7.6.3.5b-1 limits this compressive strain to 0.20, because the design is made with service loads, and research shows that the 0.20 strain limit is sufficiently far from the average failure strain to assure a β factor of 3.5 for LRFD design. Delamination due to rotation is associated with uplift or separation between the bearing pad and the load surface. Delamination does not result in a fracture or immediate failure of the bearing pad, but it results in a significant reduction in the bearing service life. Cyclic rotation associated with live loads represents the more severe delamination problem, and Eq. 14.7.6.3.5b-4 provides this design limit. However, research also shows that delamination is also influenced by maximum rotation level. CDP do not recover all of their compressive deformation after unloading, and Eq. 14.7.6.3.5b-3 recognizes approximately 20 percent residual compressive strain and limits uplift due to the maximum rotation in recognition of the delamination potential. Shear strains of the elastomer are a less meaningful measure for CDP than for steel reinforced elastomeric bearings, because shape factor has a different meaning for CDP than for other elastomeric bearing types. CDP is known to have relatively large compressive load capacity, and it is generally accepted that it can tolerate relatively large compressive strains associated with these loads. It should be noted that these compressive strains in CDP are larger than those tolerated in steel reinforced bearings, but they have been justified by experimental results for CDP that meets the requirements of these Specifications. This does not suggest that CDP is generally superior to steel reinforced elastomeric bearings. A well designed steel-reinforced bearing is likely to provide superior long-term performance, but CDP can be designed and manufactured quickly and may provide good performance under a range of conditions.

θ_s = maximum rotation of the CDP pad from the applicable service load combinations in Table 3.4.1-1 (rad.)

14.7.6.3.6—Stability

To ensure stability, the total thickness of the pad shall not exceed the least of $L/3$, $W/3$, or $D/4$.

where:

L = plan dimension of the bearing perpendicular to the axis of rotation under consideration (generally parallel to the global longitudinal bridge axis) (in.)

n = number of interior layers of elastomer, where interior layers are defined as those layers that are bonded on each face. Exterior layers are defined as those layers that are bonded only on one face. When the thickness of the exterior layer of elastomer is more than one half the thickness of an interior layer, the parameter, n , may be increased by one half for each such exterior layer.

W = plan dimension of the bearing parallel to the axis of rotation under consideration (generally parallel to the global transverse bridge axis) (in.)

D = diameter of pad (in.)

14.7.6.3.7—Reinforcement

The reinforcement in FGP shall be fiberglass with a strength in each plan direction of at least $2.2 h_{ri}$ in kip/in. For the purpose of this Article, if the layers of elastomer are of different thicknesses, h_{ri} shall be taken as the mean thickness of the two layers of the elastomer bonded to the same reinforcement. If the fiberglass reinforcement contains holes, its strength shall be increased over the minimum value specified herein by twice the gross width divided by net width.

Reinforcement for steel-reinforced elastomeric bearings designed in accordance with the provisions of this Article shall conform to the requirements of Article 14.7.5.3.5.

14.7.6.3.8—Seismic and Other Extreme Event Provisions

Expansion bearings designed according to Article 14.7.6 shall be provided with adequate seismic and other extreme event resistant anchorage to resist the horizontal forces in excess of those accommodated by shear in the pad unless the bearing is intended to act as a fuse or irreparable damage is permitted. The provisions of Article 14.7.5.3.7 shall also apply as applicable.

C14.7.6.3.6

The stability provisions in this Article are unlikely to have a significant impact upon the design of PEP, since a plain pad which has this geometry would have such a low allowable stress limit that the design would be uneconomical.

The buckling behavior of FGP and CDP is complicated because the mechanics of their behavior is not well understood. The reinforcement layers lack the stiffness of the reinforcement layers in steel-reinforced bearings and so stability theories developed for steel-reinforced bearings do not apply to CDP or FGP. The geometric limits included here are simple and conservative.

C14.7.6.3.7

The reinforcement should be strong enough to sustain the stresses induced in it when the bearing is loaded in compression. For a given compression, thicker elastomer layers lead to higher tension stresses in the reinforcement. It should be possible to relate the minimum reinforcement strength to the compressive stress that is allowed in the bearing in Article 14.7.6.3.2. The relationship has been quantified for FGP. For PEP and CDP, successful past experience is the only guide currently available.

For steel-reinforced elastomeric bearings designed in accordance with the provisions of Article 14.7.6, the equations from Article 14.7.5.3.5 are used. Although these equations are intended for steel-reinforced bearings with a higher allowable stress, the thickness of reinforcing sheets required is not significantly greater than those required by the old Method A.

14.7.7—Bronze or Copper Alloy Sliding Surfaces

14.7.7.1—Materials

Bronze or copper alloy may be used for:

- Flat sliding surfaces to accommodate translational movements,
- Curved sliding surfaces to accommodate translation and limited rotation, and
- Pins or cylinders for shaft bushings of rocker bearings or other bearings with large rotations.

Bronze sliding surfaces or castings shall conform to AASHTO M 107 (ASTM B22) and shall be made of Alloy C90500, C91100, or C86300, unless otherwise specified. The mating surface shall be structural steel, which has a Brinell hardness value at least 100 points greater than that of the bronze.

C14.7.7.1

Bronze or copper alloy sliding surfaces have a long history of application in the United States with relatively satisfactory performance of the different materials. However, there is virtually no research to substantiate the properties and characteristics of these bearings. Successful past experience is the best guide currently available.

Historically these bearings have been built from sintered bronze, lubricated bronze, or copper alloy with no distinction between the performance of the different materials. However, the evidence suggests otherwise. Sintered bronze bridge bearings have historically been included in the Standard Specifications. Sintered bronze is manufactured with a metal powder technology, which results in a porous surface structure that is usually filled with a self-lubricating material. There do not appear to be many manufacturers of sintered bronze bridge bearings at this time, and there is some evidence that past bridge bearings of this type have not always performed well. As a result, there is no reference to sintered bronze herein.

Lubricated bronze bearings are produced by a number of manufacturers, and they have a relatively good history of performance. The lubrication is forced into a pattern of recesses, and the lubrication reduces the friction and prolongs the life of the bearing. Plain bronze or copper lacks this self-lubricating quality and would appear to have poorer bearing performance. Some jurisdictions use the following guidelines for lubricant recesses (FHWA, 1991):

- The bearing surfaces should have lubricant recesses consisting of either concentric rings, with or without central circular recesses with a depth at least equal to the width of the rings or recesses.
- The recesses or rings should be arranged in a geometric pattern so that adjacent rows overlap in the direction of motion.
- The entire area of all bearing surfaces that have provision for relative motion should be lubricated by means of the lubricant-filled recesses.
- The lubricant-filled areas should comprise not less than 25 percent of the total bearing surface.
- The lubricating compound should be integrally molded at high pressure and compressed into the rings or recesses and project not less than 0.010 in. above the surrounding bronze plate.

Bronze or copper alloy sliding expansion bearings shall be evaluated for shear capacity and stability under lateral loads.

The mating surface shall be made of steel and be machined to match the geometry of the bronze surface so as to provide uniform bearing and contact.

14.7.7.2—Coefficient of Friction

The coefficient of friction may be determined by testing. In lieu of such test data, the design coefficient of friction may be taken as 0.1 for self-lubricating bronze components and 0.4 for other types.

14.7.7.3—Limit on Load

The nominal bearing stress due to combined dead and live load at the service limit state shall not exceed the values given in Table 14.7.7.3-1.

Table 14.7.7.3-1—Bearing Stress at the Service Limit State

AASHTO M 107 (ASTM B22) Bronze Alloy	Bearing Stress (ksi)
C90500—Type 1	2.0
C91100—Type 2	2.0
C86300—Type 3	8.0

14.7.7.4—Clearances and Mating Surfaces

The mating surface shall be steel that is accurately machined to match the geometry of the bronze surface and to provide uniform bearing and contact.

14.7.8—Disc Bearings

14.7.8.1—General

The dimensions of the elements of a disc bearing shall be such that hard contact between metal components, which prevents further displacement or rotation, will not occur under the least favorable combination of design displacements and rotations at the strength limit state.

Bronze or copper-alloy sliding expansion bearings should be evaluated for stability. The sliding plates inset into the metal of the pedestals or sole plates may lift during high horizontal loading. Guidelines for bearing stability evaluations may be found in Gilstad (1990). The shear capacity and stability may be increased by adding anchor bolts inserted through a wider sole plate and set in concrete.

The mating surface is commonly manufactured by a steel fabricator rather than by the bearing manufacturer who produces the bronze surface. This contractual arrangement is discouraged because it can lead to a poor fit between the two components. The bronze is weaker and softer than the steel, and fracture and excessive wear of the bronze may occur if there is inadequate quality control.

C14.7.7.2

The best available experimental evidence suggests that lubricated bronze can achieve a coefficient of friction on the order of 0.07 during its early life, while the lubricant projects above the bronze surface. The coefficient of friction is likely to increase to approximately 0.10 after the surface lubrication wears away and the bronze starts to wear down into the recessed lubricant. Copper alloy or plain bronze would cause considerably higher friction. In the absence of better information, conservative coefficients of friction of 0.1 and 0.4, respectively, are recommended for design.

C14.7.8.1

A disc bearing functions by deformation of a polyether urethane disc, which should be stiff enough to resist vertical loads without excessive deformation and yet be flexible enough to accommodate the imposed rotations without liftoff or excessive stress on other components,

The disc bearing shall be designed for the maximum strength limit state design rotation, θ_u , specified in Article 14.4.2.2.2.

For the purpose of establishing the forces and deformations imposed on a disc bearing, the axis of rotation may be taken as lying in the horizontal plane at midheight of the disc. The urethane disc shall be held in place by a positive location device.

Limiting rings may be used to partially confine the elastomer against lateral expansion. They may consist of steel rings welded to the upper and lower plates or a circular recess in each of those plates.

If a limiting ring is used, the depth of the ring should be at least $0.03D_d$, where D_d is the diameter of the disk element.

14.7.8.2—Materials

The elastomeric disc shall be made from a compound based on polyether urethane, using only virgin materials. The hardness shall be between 45 and 65 on the Shore D scale.

The metal components of the bearing shall be made from structural steel conforming to AASHTO M 270M/M 270 (ASTM A709/A709M), Grade 36, 50, or 50W or from stainless steel conforming to ASTM A240.

14.7.8.3—Elastomeric Disc

The elastomeric disc shall be held in location by a positive locator device.

At the service limit state, the disc shall be designed so that:

- Its instantaneous deflection under total load does not exceed ten percent of the thickness of the unstressed disc, and the additional deflection due to creep does not exceed eight percent of the thickness of the unstressed disc;
- The components of the bearing do not lift off each other at any location; and
- The average compressive stress on the disc does not exceed 5.0 ksi. If the outer surface of the disc is not vertical, the stress shall be computed using the smallest plan area of the disc.

such as PTFE. The urethane disc should be positively located to prevent its slipping out of place.

The primary concerns are that clearances should be maintained and that binding should be avoided even at extreme rotations. The vertical deflection, including creep, of the bearing should be taken into account.

θ_u may also be considered at the extreme event limit state.

The depth of the limiting ring should be at least $0.03D_d$ to prevent possible overriding by the urethane disc under extreme rotation conditions.

C14.7.8.2

AASHTO LRFD Bridge Construction Specifications, Article 18.3.2, provides material specifications for polyether urethane compounds.

Polyether urethane can be compounded to provide a wide range of hardnesses. The appropriate material properties must be selected as an integral part of the design process because the softest urethanes may require a limiting ring to prevent excessive compressive deflection, whereas the hardest ones may be too stiff and cause too high a resisting moment. Also, harder elastomers generally have higher ratios of creep to elastic deformation.

AASHTO M 270M/M 270 (ASTM A709/A709M), Grades 100 and 100W steel should be used only where their reduced ductility will not be detrimental.

C14.7.8.3

The primary concerns are that clearances should be maintained and that binding should be avoided even at extreme rotations. The vertical deflection, including creep, of the bearing should be taken into account.

Design of the urethane disc may be based on the assumption that it behaves as a linear elastic material, unrestrained laterally at its top and bottom surfaces. The estimates of resisting moments, so calculated, will be conservative, because they ignore creep, which reduces the moments. However, the compressive deflection due to creep should also be accounted for. Limiting rings stiffen the bearing in compression because they make the bearing behave more like a confined elastomeric bearing, i.e., a pot bearing. Their influence is conservatively ignored in the linear elastic design approach. Subject to the approval of the Engineer, design methods based on test data are permitted.

No liftoff of components can be tolerated; therefore, any uplift restraint device should have sufficiently small vertical slack to ensure the correct location of all components when the compressive load is reapplied.

If a PTFE slider is used, the stresses on the PTFE slider shall not exceed the values for average and edge stresses given in Article 14.7.2.4 for the service limit state. The effect of moments induced by the urethane disc shall be included in the stress analysis.

14.7.8.4—Shear Resisting Mechanism

In fixed and guided bearings, a shear-resisting mechanism shall be provided to transmit horizontal forces between the upper and lower steel plates. It shall be capable of resisting a horizontal force in any direction equal to the larger of the design shear force at the strength and extreme event limit states or 15 percent of the design vertical load at the service limit state.

The horizontal design clearance between the upper and lower components of the shear-restricting mechanism shall not exceed the value for guide bars given in Article 14.7.9.

14.7.8.5—Steel Plates

The provisions of Sections 3, 4, and 6 of these Specifications shall apply as appropriate.

The thickness of each of the upper and lower steel plates shall not be less than $0.045 D_d$, where D_d is the diameter of the disk element, if it is in direct contact with a steel girder or distribution plate, or $0.06 D_d$ if it bears directly on grout or concrete.

14.7.9—Guides and Restraints

14.7.9.1—General

Guides may be used to prevent movement in one direction. Restraints may be used to permit only limited movement in one or more directions. Guides and restraints shall have a low-friction material at their sliding contact surfaces.

Rotational experiments have shown that uplift occurs at relatively small moments and rotations in disc bearings. There are concerns that this could lead to edge loading on PTFE sliding surfaces and increase the potential for damage to the PTFE. Bearings passing the test requirements of Article 18.3.4.4.4 of the LRFD Bridge Construction Specification should assure against any damage to the PTFE.

C14.7.8.4

The shear resisting device may be placed either inside or outside the urethane disc. If shear is carried by a separate transfer device external to the bearing, such as opposing concrete blocks, the bearing itself may be unguided.

In unguided bearings, the shear force that should be transmitted through the body of the bearing is μP , where μ is the coefficient of friction of the PTFE slider and P is the vertical load on the bearing. This may be carried by the urethane disc without a separate shear-resisting device, provided that the disc is held in place by positive locating devices, such as recesses in the top and bottom plates.

The 15 percent factor applied to the service limit state vertical load approximates a strength limit state horizontal design force.

Maximum extreme event limit state forces should be considered when the bearing is not intended to act as a fuse or irreparable damage is not permitted.

C14.7.8.5

The plates should be thick enough to uniformly distribute the concentrated load in the bearing. Distribution plates should be designed in accordance with Article 14.8.

C14.7.9.1

Guides are frequently required to control the direction of movement of a bearing. If the horizontal force becomes too large to be carried reliably and economically on a guided bearing, a separate guide system may be used.

14.7.9.2—Design Loads

Guides or restraints shall be designed at the strength limit state for:

- The horizontal force from applicable strength load combinations specified in Table 3.4.1-1, but shall not be taken less than
- 15 percent of the total vertical force from applicable service load combinations specified in Table 3.4.1-1 acting on all the bearings at the bent divided by the number of guided bearings at the bent.

Guides and restraints shall be designed for applicable seismic or other extreme event forces using the extreme event limit state load combinations of Table 3.4.1-1 and, in the case of seismic, the provisions in Article 3.10.9.

14.7.9.3—Materials

For steel bearings, the guide or restraint shall be made from steel conforming to AASHTO M 270M/M 270 (ASTM A709/A709M), Grades 36, 50, or 50W or stainless steel conforming to ASTM A240. For aluminum bearings, the guide may also be aluminum.

The low-friction interface material shall be approved by the Engineer.

14.7.9.4—Geometric Requirements

Guides shall be parallel, long enough to accommodate the full design displacement of the bearing in the sliding direction, and shall permit a minimum of 0.03125-in. and a maximum of 0.0625-in. free slip in the restrained direction. Guides shall be designed to avoid binding under all design loads and displacements, including rotation.

14.7.9.5—Design Basis*14.7.9.5.1—Load Location*

The horizontal force acting on the guide or restraint shall be assumed to act at the centroid of the low-friction interface material. Design of the connection between the guide or restraint and the body of the bearing system shall consider both shear and the overturning moments so caused.

C14.7.9.2

The 15 percent factor applied to the service limit state vertical load approximates a minimum strength limit state horizontal design force. This design force is intended to account for responses that cannot be calculated reliably, such as horizontal bending or twisting of a bridge deck caused by nonuniform or time-dependent thermal effects.

Large ratios of horizontal to vertical load can lead to bearing instability, in which case a separate guide system should be considered.

Maximum extreme event limit state forces should be considered when the bearing is not intended to act as a fuse or irreparable damage is not permitted.

C14.7.9.3

Many different low-friction materials have been used in the past. Because the total transverse force at a bent is usually smaller than the total vertical force, the guides may contribute less toward the total longitudinal friction force than the primary sliding surfaces. Thus, material may be used that is more robust but causes higher friction than the primary material. Filled PTFE is common, and other proprietary materials, such as PTFE-impregnated metals, have proven effective.

C14.7.9.4

Guides must be parallel to avoid binding and inducing longitudinal resistance. The clearances in the transverse direction are fairly tight and are intended to ensure that excessive slack does not exist in the system. Free transverse slip has the advantage that transverse restraint forces are not induced, but if this is the objective a nonguided bearing is preferable. On the other hand, if applied transverse loads are intended to be shared among several bearings, free slip causes the load to be distributed unevenly, possibly leading to overloading of one guide.

C14.7.9.5.1

Guides are often bolted to the slider plate to avoid welding distortions. Horizontal forces applied to the guide cause some overturning moment, which must be resisted by the bolts in addition to shear. The tension in the bolt can be reduced by using a wider guide bar. If high-strength bolts are used, the threaded hole in the plate should be deep enough to develop the full tensile strength of the bolt.

The design and detailing of bearing components resisting lateral loads, including seismic and other extreme event loads determined as specified in Article 14.6.3.1, shall provide adequate strength and ductility. Guide bars and keeper rings or nuts at the ends of pins and similar devices shall either be designed to resist all imposed loads or an alternative load path shall be provided that engages before the relative movement of the substructure and superstructure is excessive.

14.7.9.5.2—Contact Stress

The contact stress on the low-friction material shall not exceed that recommended by the manufacturer. For PTFE, the stresses at the service limit state shall not exceed those specified in Table 14.7.2.4-1 under sustained loading or 1.25 times those stresses for short-term loading.

14.7.9.6—Attachment of Low-Friction Material

The low-friction material shall be attached by at least any two of the following three methods:

- Mechanical fastening,
- Bonding, and
- Mechanical interlocking with a metal substrate.

14.7.10—Other Bearing Systems

Bearing systems made from components not specified in Articles 14.7.1 through 14.7.9 may also be used, subject to the approval of the Engineer. Such bearings shall be adequate to resist the forces and deformations imposed on them at the service and strength limit states without material distress and without inducing deformations detrimental to their proper functioning. At the extreme event limit state, bearings which are designed to act as fuses or sustain irreparable damage may be permitted by the Owner provided loss of span is prevented.

Some press-fit guide bar details in common use have proven unsatisfactory in resisting horizontal loads. When analyzing such designs, consideration should be given to the possibility of rolling the bar in the recess (SCEF, 1991).

Where guide bars are recessed into a machined slot, tolerances should be specified to provide a press fit. The guide bar should also be welded or bolted to resist overturning.

Past earthquakes have shown that guide and keeper bars and keeper rings or nuts at the ends of pins and other guiding devices have failed, even under moderate seismic loads. In an experimental investigation of the strength and deformation characteristics of rocker bearings (Mander et al., 1993), it was found that adequately sized pintles are sometimes capable of providing the necessary resistance to seismic loads.

C14.7.9.5.2

Appropriate compressive stresses for proprietary materials should be developed by the Manufacturer and approved by the Engineer on the basis of test evidence. Strength, cold flow, wear, and friction coefficient should be taken into consideration.

On conventional materials, higher stresses are allowed for short-term loading because the limitations in Table 14.7.2.4-1 are based partly on creep considerations. Short-term loading includes wind, earthquake, etc., but not thermal or gravity effects.

C14.7.9.6

Some difficulties have been experienced where PTFE is attached to the metal backing plates by bonding alone. Ultra-violet light attacks the PTFE surface that is etched prior to bonding, and this has caused bond failures. Thus, at least two separate methods of attachment are required. Mechanical fasteners should be countersunk to avoid gouging the mating surface.

C14.7.10

Tests cannot be prescribed unless the nature of the bearing is known. In appraising an alternative bearing system, the Engineer should plan the test program carefully because the tests constitute a larger part of the quality assurance program than is the case with more widely used bearings.

In bearings that rely on elastomeric components, aspects of behavior, such as time-dependent effects, response to cyclic loading, temperature sensitivity, etc., should be investigated.

The dimensions of the bearing shall be chosen to provide for adequate movements at all times. Materials shall have sufficient strength, stiffness, and resistance to creep and decay to ensure the proper functioning of the bearing throughout the design life of the bridge.

The Engineer shall determine the tests that the bearing shall satisfy. The tests shall be designed to demonstrate any potential weakness in the system under individual compressive, shear, or rotational loading or combinations thereof. Testing under sustained and cyclic loading shall be required.

14.8—LOAD PLATES AND ANCHORAGE FOR BEARINGS

14.8.1—Plates for Load Distribution

The bearing, together with any additional plates, shall be designed so that:

- The combined system is stiff enough to prevent distortions of the bearing that would impair its proper functioning when subjected to service and strength limit state loadings, and maximum extreme event loadings when required;
- The stresses imposed on the supporting structure satisfy the limits specified by the Engineer and Sections 5, 6, 7, or 8; and
- The bearing can be replaced within the jacking height limits specified by the Engineer without damage to the bearing, distribution plates, or supporting structure. If no limit is given, a height of 0.375 in. shall be used.

Resistance of steel components shall be determined in accordance with Section 6.

Some bearing tests are very costly to perform. Other bearing tests cannot be performed because there is no available test equipment in the United States. At the present time, the largest U.S. facility for testing bearings in combined axial load and shear is the Seismic Response Modification Device Test Facility at the University of California, San Diego constructed by Caltrans. This facility can test bearings of all kinds up to 12,000-kip axial load capacity and 2,000-kip transverse load capacity (HITEC, 2002). Nevertheless, the following test requirements should be carefully considered before specifying them (SCEF, 1991):

- Vertical loads exceeding 5,000 kips,
- Horizontal loads exceeding 500 kips,
- The simultaneous application of horizontal and vertical load where the horizontal load exceeds 75 percent of the vertical load,
- Triaxial test loading,
- The requirement for dynamic rotation of the test bearing while under vertical load, and
- Coefficient of friction test movements with normal loads greater than 250 kips.

C14.8.1

Large forces may be concentrated in a bearing that must be distributed so as not to damage the supporting structure. In general, metal rocker and roller bearings cause the most concentrated loads, followed by pots, discs, and sphericals, whereas elastomeric bearings cause the least concentrated loads. Masonry plates may be required to prevent damage to concrete or grout surfaces.

Many simplified methods have been used to design masonry plates, some based on strength and some on stiffness. Several studies have indicated that masonry plates are less effective in distributing the load than these simplified methods would suggest, but the cost of heavy load distribution plates would be considerable (McEwen and Spencer, 1981; Saxena and McEwen, 1986). The present design rules represent an attempt to provide a uniform basis for design that lies within the range of traditional methods. Design based on more precise information, such as finite element analysis, is preferable but may not be practical in many cases.

In lieu of a more refined analysis, the load from a bearing fully supported by a grout bed may be assumed to distribute at a slope of 1.5:1, horizontal to vertical, from the edge of the smallest element of the bearing that resists the compressive load.

The use and design of bearing stiffeners on steel girders shall comply with Section 6.

Sole plate and base plate connections shall be adequate to resist lateral loads at the strength limit state. These connections shall also be adequate to resist the maximum seismic and other extreme event lateral loads unless the bearings are designed to act as fuses or sustain irreparable damage. Sole plates shall be extended to allow for anchor bolt inserts, when required.

14.8.2—Tapered Plates

If, under full permanent load at the mean annual temperature for the bridge site (at the service limit state with all load factors equal to 1.0), the inclination of the underside of the girder to the horizontal exceeds 0.01 rad., a tapered plate shall be used in order to provide a level surface.

14.8.3—Anchorage and Anchor Bolts

14.8.3.1—General

All load distribution plates and bearings with external steel plates shall be positively secured to their associated superstructure or substructure element by bolting or welding.

All girders shall be positively secured to supporting bearings by a connection that can resist the horizontal forces that may be imposed on it unless fusing or irreparable damage is permitted at the extreme event limit state. Separation of bearing components shall not be permitted at the strength limit state. Connections shall resist the least favorable combination of loads at the strength limit state and shall be installed wherever deemed necessary to prevent separation.

Trusses, girders, and rolled beams shall be securely anchored to the substructure. Where possible, anchor bolts should be cast in substructure concrete, otherwise anchor bolts may be grouted in place. Anchor bolts may be swedged or threaded to secure a satisfactory grip upon the material used to embed them in the holes.

The resistance of the anchor bolts shall be adequate for loads at the strength limit state and for the maximum loads at the extreme event limit state unless the bearings are designed to act as fuses or sustain irreparable damage.

The tensile resistance of anchor bolts shall be determined as specified in Article 6.13.2.10.2.

Some types of bearings were only developed in the last 20 or 30 yr, so their longevity has yet to be proven in the field. Hence the requirement for bearing replaceability.

One common way to provide for replacement is to use a masonry plate, attached to the concrete pier head by embedded anchors or anchor bolts. The bearing can then be attached to the masonry plate by seating it in a machined recess and bolting it down. The bridge needs then to be lifted only through a height equal to the depth of the recess in order to replace the bearing. The deformation tolerance of joints and seals, as well as the stresses in the structure, should be considered in determining the allowable jacking height.

C14.8.2

Tapered plates may be used to counteract the effects of end slope in a girder. In all but short-span bridges, the dead load will dominate the forces on the bearing, so the tapered plate should be designed to provide zero rotation of the girder under this condition. The limit of 0.01 rad. out of level corresponds to the 0.01 rad. component, which is required in the design rotation in Article 14.4.

C14.8.3.1

Bearings should be anchored securely to the support to prevent their moving out of place during construction or over the life of the bridge. Elastomeric bearings may be left without anchorage if adequate friction is available. A design coefficient of friction of 0.2 may be assumed between elastomer and clean concrete or steel.

Girders may be located on bearings by bolts or pintles. The latter provide no uplift capacity. Welding may be used, provided that it does not cause damage to the bearing or difficulties with replacement.

Uplift should be prevented both among the major elements, such as the girder, bearing, support, and between the individual components of a bearing. If uplift occurs, some parts of the structure could be misaligned when contact is regained, causing damage.

Anchor bolts are very susceptible to brittle failure during earthquakes or other extreme events. To increase ductility, it has been recommended in Astaneh-Asl et al. (1994) to use upset anchor bolts placed inside hollow sleeve pipes and oversized holes in the masonry plate. Thus, deformable bearing types may use the anchor bolts as the ductile element (Cook and Klingner, 1992).

Bearings designed for rigid load transfer, especially at the extreme event limit state, should not be seated on grout pads or other bedding materials that can create a sliding surface and reduce the horizontal resistance.

Seismic loading of the anchor bolts has often resulted in concrete damage, especially when they were too close to the edge of the bearing seat. Guidelines for evaluating

The shear resistance of anchor bolts and dowels shall be determined as specified in Article 6.13.2.12.

The resistance of anchor bolts in combined tension and shear shall be determined as specified in Article 6.13.2.11.

The bearing resistance of the concrete shall be taken as specified in Article 5.7.5. The modification factor, m , shall be based on a nonuniformly distributed bearing stress.

14.8.3.2—Seismic and Other Extreme Event Design and Detailing Requirements

Sufficient reinforcement shall be provided around the anchor bolts to develop the level of horizontal forces considered at the extreme event limit state and anchor them into the mass of the substructure unit. Potential concrete crack surfaces next to the bearing anchorage shall be identified and their shear friction capacity evaluated as required.

14.9—CORROSION PROTECTION

All exposed steel parts of bearings not made from stainless steel shall be protected against corrosion by zinc metalization, hot-dip galvanizing, or a paint system approved by the Engineer. A combination of zinc metalization or hot-dip galvanizing and a paint system may be used.

14.10—REFERENCES

AASHTO. 2002. *Standard Specifications for Highway Bridges*, 17th Edition, HB-17. American Association of State Highway and Transportation Officials, Washington, DC.

AASHTO. 2010. *Guide Specifications for Seismic Isolation Design*, Second Edition, GSID-3. American Association of State Highway and Transportation Officials, Washington, DC.

ACI. 1999. *Building Code Requirements for Structural Concrete*, 318-99 and Commentary, 318R-99. American Concrete Institute, Farmington Hills, MI.

edge distance effects and concrete strength requirements may be found in Ueda et al. (1990), among others.

For global design of anchorages to concrete, refer to *Building Code Requirements for Structural Concrete* (ACI 318-05), Appendix D.

As an approximation, the bearing stress may be assumed to vary linearly from zero at the end of the embedded length to its maximum value at the top surface of concrete.

C14.9

The use of stainless steel is the most reliable protection against corrosion because coatings of any sort are subject to damage by wear or mechanical impact. This is particularly important in bearings where metal-to-metal contact is inevitable, such as rocker and roller bearings. Weathering steel is excluded because it forms an oxide coating that may inhibit the proper functioning of the bearing.

When using hot-dip galvanizing for corrosion protection, several factors must be considered. Embrittlement of very high-strength fasteners, such as AASHTO M 253 (ASTM A490) bolts, may occur due to acid cleaning (pickling) before galvanizing, and quenched and tempered material, such as Grade 70W and 100W, may undergo changes in mechanical properties, so galvanizing these should be avoided (see ASTM A143 on avoiding embrittlement). With good practice, commonly used steels, such as Grades 36, 50, and 50W, should not be adversely affected if their chemistry and the assembly's details are compatible (see ASTM A385 on ensuring high-quality coating). Certain types of bearings, such as intricate pot or spherical bearings, are not suitable for hot-dip galvanizing.

- ACI. 2005. *Building Code Requirements for Structural Concrete*, 318-05. American Concrete Institute, Farmington Hills, MI.
- Astaneh-Asl, A., B. Bolt, K. M. McMullin, R. R. Donikian, D. Modjtahedi, and S. Cho. 1994. *Seismic Performance of Steel Bridges during the 1994 Northridge Earthquake*, Report No. UCB/CE-STEEL-94/01. Report to the California Department of Transportation, April 1994.
- Campbell, T. I., and W. L. Kong. 1987. *TFE Sliding Surfaces in Bridge Bearings*, Report ME-87-06. Ontario Ministry of Transportation and Communications, Downsview, ON.
- Cook, A.R., and R. E. Klingner. 1992. "Ductile Multiple-Anchor Steel-to-Concrete Connections," *Journal of Structural Engineering*. American Society of Civil Engineers, New York, NY, Vol. 118, No. 6, June 1992, pp. 1645–1665.
- Crozier, W. F., J. R. Stoker, V. C. Martin, and E. F. Nordlin. 1979. *A Laboratory Evaluation of Full-Size Elastomeric Bridge Bearing Pads*, Research Report CA DOT, TL-6574-1-74-26. Highway Research Report, Washington, DC, June 1979.
- Dexter, R. J., R. J. Connor, and M. R. Kaczinski. 1997. *Fatigue Design of Modular Bridge Joint Systems*, NCHRP Report 402. Transportation Research Board, National Research Council, Washington, DC.
- Dexter, R. J., M. J. Mutziger, and C. B. Osberg. 2002. *Performance Testing for Modular Bridge Joint Systems*, NCHRP Report 467. Transportation Research Board, National Research Council, Washington, DC.
- Gent, A. N. 1964. "Elastic Stability of Rubber Compression Springs," *Journal of Mechanical Engineering Science*. Abstract, Vol. 86, No. 3, p. 86.
- Gilstad, D. E. 1990. "Bridge Bearings and Stability," *Journal of Structural Engineering*. American Society of Civil Engineers, New York, NY, Vol. 116, No. 5, May 1990.
- HITEC. 2002. *Guidelines for Testing Large Seismic Isolator and Energy Dissipation Devices*, HITEC/CERF Report 40600. American Society of Civil Engineers, Washington, DC.
- Jacobsen, F. K., and R. K. Taylor. 1971. *TFE Expansion Bearings for Highway Bridges*, Report No. RDR-31. Illinois Department of Transportation, Springfield, IL.
- Lehman, D. E., C. W. Roeder, R. Larson, and K. Curtin. 2003. *Cotton Duck Bearing Pads: Engineering Evaluation and Design Recommendations*, Research Report No. WA-RD 569.1. Washington State Department of Transportation, Olympia, WA.
- McEwen, E. E., and G. D. Spencer. 1981. "Finite Element Analysis and Experimental Results Concerning Distribution of Stress under Pot Bearings." In *Proc., 1st World Congress on Bearings and Sealants*, Publication SP-70. American Concrete Institute, Farmington Hills, MI.
- Mander, J. B, J. H. Kim, and S. S. Chen. 1993. "Experimental Performance and Modeling Study of a 30-Year-Old Bridge with Steel Bearings," *Transportation Research Record 1393*. Transportation Research Board, National Research Council, Washington, DC.
- Nordlin, E. F., J. F. Boss, and R. R. Trimble. 1970. "Tetrafluoroethylene. TFE as a Bridge Bearing Material," *Research Report No. M and R 64642-2*. California Department of Transportation, Sacramento, CA.
- Nowak, A. S., and J. A. Laman. 1995. "Monitoring Bridge Load Spectra," *IABSE Symposium, Extending the Lifespan of Structures*. San Francisco, CA.
- Pattis, A. 1993. "Dynamische Bemessung von Wasserdichten Fahrbahnübergangen-Modulsysteme (Dynamic Design of Waterproof Modular Expansion Joints)." Ph.D. Dissertation. Civil Engineering and Architecture, University of Innsbruck, Austria, December 1993.
- Roark, R. J., and W. C. Young. 1976. *Formulas for Stress and Strain*, Fifth Edition. McGraw Hill, New York, NY.
- Roeder, C. W. 2000. *LRFD Design Criteria for Cotton Duck Pad Bridge Bearing*, NCHRP Web Doc 24. Available online: http://onlinepubs.trb.org/onlinepubs/nchrp/nchrp_w24.pdf

- Roeder, C. W. 2002. *Thermal Design Procedure for Steel and Concrete Bridges*, Final Report for NCHRP 20-07/106. Transportation Research Board, National Research Council, Washington, D.C.
- Roeder, C. W., and J. F. Stanton. 1983. "Elastomeric Bearings: A State of the Art," *Journal of the Structural Division*. American Society of Civil Engineers, New York, NY, Vol. 109, No. 12, December 1983, pp. 2853–2871.
- Roeder, C. W., and J. F. Stanton. 1986. "Failure Modes of Elastomeric Bearings and Influence of Manufacturing Methods." In Vol. 1, *Proc. of 2nd World Congress on Bearings and Sealants*, Publication SP-94-17. 84-AB. American Concrete Institute, Farmington Hills, MI.
- Roeder, C. W., and J. F. Stanton. 1991. "State of the Art Elastomeric Bridge Bearing Design," *ACI Structural Journal*. American Concrete Institute, Farmington Hills, MI, Vol. 88, No. 1, pp. 31–41.
- Roeder, C. W., J. F. Stanton, and T. Feller. 1990. "Low Temperature Performance of Elastomers," *Journal of Cold Regions*. American Society of Civil Engineers, New York, NY, Vol. 4, No. 3, September 1990, pp. 113–132.
- Roeder, C. W., J. F. Stanton, and A. W. Taylor. 1987. *Performance of Elastomeric Bearings*, NCHRP Report 298. Transportation Research Board, National Research Council, Washington, DC, October 1987.
- Roeder, C. W., J. F. Stanton, and A. W. Taylor. 1990. "Fatigue of Steel-Reinforced Elastomeric Bearings," *Journal of Structural Division*. American Society of Civil Engineers, New York, NY, Vol. 116, No. 2, February 1990.
- Saxena, A., and E. E. McEwen. 1986. "Behavior of Masonry Bearing Plates in Highway Bridges." In *Proc. of 2nd World Congress on Bearings and Sealants*, ACI Publication SP-94-31. 84-AB. American Concrete Institute, Farmington Hills, MI.
- Schilling, C. G. 1990. *Variable Amplitude Load Fatigue, Task A—Literature Review: Volume I—Traffic Loading and Bridge Response*, FHWA/RD/87-059. Federal Highway Administration, U.S. Department of Transportation, Washington, DC, July 1990.
- Stanton, J. F., and C. W. Roeder. 1982. *Elastomeric Bearings Design, Construction, and Materials*, NCHRP Report 248. Transportation Research Board, National Research Council, Washington, DC, August 1982.
- Stanton, J. F., C. W. Roeder, and T. I. Campbell. 1999. *High-Load Multi-Rotational Bridge Bearings*, NCHRP Report 432. Transportation Research Board, National Research Council, Washington DC.
- Stanton, J. F., G. Scroggins, A. W. Taylor, and C. W. Roeder. 1990. "Stability of Laminated Elastomeric Bearings," *Journal of Engineering Mechanics*. American Society of Civil Engineers, New York, NY, Vol. 116, No. 6, June 1990, pp. 1351–1371.
- Stanton, J. F., C. W. Roeder, P. Mackenzie-Helnwein, C. White, C. Kuester, and B. Craig. 2008. *Rotation Limits for Elastomeric Bearings*, NCHRP Report 596. Transportation Research Board, National Research Council, Washington, DC, February 2008.
- Subcommittee for High Load Multi-Rotational Bearings, FHWA Region 3 Structural Committee for Economical Fabrication. 1991. *Structural Bearing Specification*. Federal Highway Administration, U.S. Department of Transportation, Washington, DC, October 1991.
- Tschemmerneegg, F. 1991. "The Design of Modular Expansion Joints." Proceedings of the 3rd World Congress on Joint Sealing and Bearing Systems for Concrete Structures. Toronto, ON.
- Tschemmerneegg, F., and A. Pattis. 1994. "Using the Concept of Fatigue Test to Design a Modular Expansion Joint." Transportation Research Board 73rd Annual Meeting, January 1994.
- Ueda, T., S. Kitipornchai, and K. Ling. 1990. "Experimental Investigation of Anchor Bolts under Shear," *Journal of Structural Engineering*. American Society of Civil Engineers, New York, NY, Vol. 116, No. 4, April 1990, pp. 910–924.
- U.S. Department of Defense. 1989. *Cloth, Duck, Cotton or Cotton-Polyester Blend, Synthetic Rubber, Impregnated, and Laminated, Oil Resistant*, Military Specification MIL-C-882E. Available online at: <http://assist.daps.dla.mil>. (Requires site registration.)

SECTION 15: DESIGN OF SOUND BARRIERS

TABLE OF CONTENTS

15.1—SCOPE 15-1

15.2—DEFINITIONS 15-1

15.3—NOTATION 15-1

15.4—GENERAL FEATURES 15-2

 15.4.1—Functional Requirements 15-2

 15.4.1.1—General 15-2

 15.4.1.2—Lateral Clearance 15-2

 15.4.2—Drainage 15-2

 15.4.3—Emergency Responders and Maintenance Access 15-2

 15.4.4—Differential Settlement of Foundations 15-3

15.5—LIMIT STATES AND RESISTANCE FACTORS 15-3

 15.5.1—General 15-3

 15.5.2—Service Limit State 15-3

 15.5.3—Strength Limit State 15-3

 15.5.4—Extreme Event Limit State 15-4

15.6—EXPANSION DEVICES 15-4

 15.6.1—General 15-4

 15.6.2—Structure-Mounted Sound Barriers 15-4

 15.6.3—Ground-Mounted Sound Barriers 15-5

15.7—SOUND BARRIERS INSTALLED ON EXISTING BRIDGES 15-5

15.8—LOADS 15-5

 15.8.1—General 15-5

 15.8.2—Wind Load 15-5

 15.8.3—Earth Load 15-9

 15.8.4—Vehicular Collision Forces 15-9

15.9—FOUNDATION DESIGN 15-12

 15.9.1—General 15-12

 15.9.2—Determination of Soil and Rock Properties 15-12

 15.9.3—Limit States 15-12

 15.9.4—Resistance Requirements 15-12

 15.9.5—Resistance Factors 15-13

 15.9.6—Loading 15-13

 15.9.7—Movement and Stability at the Service Limit State 15-13

 15.9.7.1—Movement 15-13

 15.9.7.2—Overall Stability 15-13

 15.9.8—Safety against Geotechnical Failure at the Strength Limit State 15-13

 15.9.9—Seismic Design 15-13

 15.9.10—Corrosion Protection 15-13

 15.9.11—Drainage 15-14

15.10—REFERENCES 15-14

DESIGN OF SOUND BARRIERS

15.1—SCOPE

This Section applies to the structural design of sound barriers which are either ground-mounted or structure-mounted and the design of the foundations of ground-mounted sound barriers.

C15.1

This Section specifies the design forces and the design requirements unique to sound barriers constructed along highways. This Section does not cover sound barriers constructed adjacent to railroad tracks or the acoustical requirements for sound barriers.

These provisions are largely based on the requirements of the *Guide Specifications for Structural Design of Sound Barriers* (1989).

15.2—DEFINITIONS

Clear Zone—The total roadside border area, starting at the edge of the traveled way, available for safe use by errant vehicles.

Crashworthy—A traffic railing system that has been successfully crash-tested to a currently acceptable crash test matrix and test level or one that can be geometrically and structurally evaluated as equal to a crash-tested system.

Ground-Mounted Sound Barriers—Sound barriers supported on shallow or deep foundations.

Post-and-Panel Construction—Type of sound barrier construction consisting of vertical posts supported on a structure or on the foundations and panels spanning horizontally between adjacent posts.

Right-of-Way—The land on which a roadway and its associated facilities and appurtenances are located. The highway right-of-way is owned and maintained by the agency having jurisdiction over that specific roadway.

Right-of-Way Line—The boundary of the right-of-way.

Sound Barrier—A wall constructed along a highway to lower the highway noise level in the area behind the wall.

Sound Barrier Setback—The distance between the point on the traffic face of the sound barrier wall that is closest to traffic and the closest point on the traffic face of the traffic railing the sound barrier is mounted on or located behind as defined in Article 15.8.4.

Structure-Mounted Sound Barriers—Sound barrier supported on bridges, crashworthy traffic railings, or retaining walls.

Traffic Railing—Synonymous with vehicular railing; used as a bridge or structure-mounted railing rather than as a guardrail or median barrier, as in other publications.

Vehicular Railing—Synonymous with traffic railing; used as a bridge or structure-mounted railing rather than as a guardrail or median barrier, as in other publications.

15.3—NOTATION

S = setback distance of sound barrier (15.8.4)

V_0 = friction velocity; a meteorological wind characteristic for various upwind surface characteristics (mph) (15.8.2)

V_{30} = wind speed at 30.0 ft above low ground or water level (mph) (15.8.2)

Z_0 = friction length of upstream fetch; a meteorological wind characteristic (ft) (15.8.2)

ϕ = soil angle of internal friction (degrees) (C15.4.2)

γ_p = load factor for permanent loads (15.9.9)

15.4—GENERAL FEATURES

15.4.1—Functional Requirements

15.4.1.1—General

Consult a roadway professional for sight-distance and sound barrier height and length requirements.

15.4.1.2—Lateral Clearance

Unless dictated by site conditions and approved by the Owner, sound barriers shall be located outside the clear zone or, when the clear zone is wider than the distance between the edge of the traffic lanes and the edge of the available right-of-way, just inside the right-of-way.

C15.4.1.2

Locating the sound barrier farther from the edge of the traffic lanes reduces the possibility of vehicular collision with the barrier. The most desirable location for a sound barrier is outside the clear zone, which minimizes the possibility of vehicular collision. In many cases, because sound barriers are typically used in urban areas, the width of available right-of-way is less than the width of the clear zone.

When conditions make it impractical to locate the sound barrier at adequate distance from the edge of traffic lanes and the sound barrier is mounted on a traffic barrier, the recommended minimum clearance from the edge of traffic lanes to the face of the traffic barrier is 10.0 ft. Lateral clearances greater than 10.0 ft should be used when feasible. Guardrail or other traffic barriers should be considered for use when the sound barrier is located inside the clear zone.

In addition to safety considerations, maintenance requirements should be considered in deciding sound barrier locations. Sound barriers placed within the area between the shoulder and right-of-way line complicate the ongoing maintenance and landscaping operations and lead to increased costs, especially if landscaping is placed on both sides of the sound barrier. Special consideration should be given to maintaining the adjoining land behind the sound barrier and adjacent to the right-of-way line.

15.4.2—Drainage

Adequate drainage shall be provided along sound barriers.

C15.4.2

It is important to have drainage facilities along sound barriers to ensure soil stability. Soils with an angle of internal friction, ϕ , of 25 degrees or less may develop flowing characteristics when saturated. Limits on fines, especially clay and peat, should be specified.

15.4.3—Emergency Responders and Maintenance Access

Provisions for emergency and maintenance access shall be provided. Local fire department requirements for fire hose and emergency access shall be satisfied.

C15.4.3

Provisions may be necessary to allow firefighters and hazardous material clean-up crews access to fire hydrants on the opposite side of the sound barrier. The designer should consult with local fire and emergency officials regarding their specific needs.

Shorter barriers may be traversed by throwing the fire hose over the wall. Taller barriers may require an opening through which the hose is passed. Such an opening can consist of a formed or cored hole, a hollow

masonry block turned on its side, a maintenance access gate, etc. A small sign may be placed adjacent to the emergency access location on the traffic side of the sound barrier. This sign would bear the street name on which the hydrant is located, thus aiding emergency crews in identifying the hydrant nearest the opening.

Access to the back side of the sound barrier must be provided if the area is to be maintained. In subdivision areas, access can be via local streets, when available. If access is not available via local streets, access gates or openings are essential at intervals along the sound barrier. Offset barriers concealing the access opening must be overlapped a minimum of 2.5 times the offset distance in order to maintain the integrity of the main barrier's sound attenuation. Location of the access openings should be coordinated with the appropriate agency or land owner.

15.4.4—Differential Settlement of Foundations

For long masonry sound barriers supported on spread footings, provisions should be made to accommodate differential settlement.

C15.4.4

Provisions should be made to accommodate differential settlement when sound barriers are supported on continuous spread or trench footings or cap beams.

15.5—LIMIT STATES AND RESISTANCE FACTORS

15.5.1—General

Structural components shall be proportioned to satisfy the requirements at all appropriate service, strength, and extreme event limit states.

Limit states applicable to sound barrier foundations design shall be in accordance with Article 15.9. Limit states applicable to the structural design of sound barrier components shall be as presented herein.

The limit states shall apply using the applicable load combinations in Table 3.4.1-1 and the loads specified herein.

Where masonry or other proprietary walls are utilized, the Owner shall approve the design specifications to be used.

C15.5.1

These Specifications do not include design provisions for masonry structures. Design provisions for masonry structures should be taken from other specifications.

15.5.2—Service Limit State

The resistance factors for the service limit states for post, wall panel and foundation components shall be as specified in Article 1.3.2.1. Design for service limit states shall be in accordance with the applicable requirements of Articles 5.5.2, 6.5.2, 7.5.1, and 8.5.1.

15.5.3—Strength Limit State

The resistance factors for the strength limit states for post, wall panel and foundation components shall be as specified in Articles 5.5.4, 6.5.4, 7.5.4, and 8.5.2.

15.5.4—Extreme Event Limit State

The resistance factors for the extreme event limit states for post, wall panel, and foundation components shall be as specified in Article 1.3.2.1.

15.6—EXPANSION DEVICES

15.6.1—General

Adequate noise sealant material shall be placed at expansion joints of sound barriers.

15.6.2—Structure-Mounted Sound Barriers

Except for post-and-panel construction, as a minimum, expansion joints shall be provided in the sound barriers at the location of expansion joints in the supporting structure, at bridge intermediate supports, and at the centerline of bridge spans.

When post-and-panel construction is utilized, wall panels may be allowed to bridge the expansion joints in, or at the ends of, the deck of the supporting structure where the panels seat width on the posts is sufficient to accommodate the expansion joint movements and the dimensional and installation tolerances; otherwise, posts shall be placed on either side of any expansion joint in the supporting structure.

C15.6.2

When the type of construction utilized for sound barriers does not inherently allow movements between the sound barrier components, allowance should be made to accommodate the movement and deformations of the supporting structure. Therefore, expansion devices are required in the sound barriers at expansion joint locations in order not to restrict the movement of the expansion joints of the supporting structures.

Sound barriers mounted on bridges stiffen the supporting bridge superstructures, resulting in longitudinal stresses developing in the sound barriers. The higher curvature of bridge girders at high moment locations near midspans and, for continuous bridges, at intermediate supports increases the magnitude of these stresses. Providing expansion joints in the sound barriers at these locations reduces the effect of the stiffness of the sound barrier on the deformations of the girders and the stresses in the barrier due to live load deflection of the bridge.

When mounted on bridges, additional expansion devices in the sound barrier may be utilized as required to further minimize the stresses on the barrier due to the live load deflection of the bridge.

Post-and-panel sound barriers inherently provide an expansion joint at either end of each wall panel. Typical posts are made of steel rolled I-shapes or concrete I-sections. Characteristically, the seat width of the wall panels on the posts is relatively small as it corresponds to the width of the post flange overhang on either side of the post web. These typical seat widths provide for dimensional and installation tolerances and dimensional changes caused by panel deformations due to applied loads and temperature changes. For smaller post flange widths, unless a post is provided on either side of an expansion joint in the supporting structure, the change in the opening of the structure expansion joint may be larger than the panel seat width on the post and may cause the failure of the panel straddling the structure expansion joint due to the loss of panel seat width.

15.6.3—Ground-Mounted Sound Barriers

Except for post-and-panel construction, expansion devices shall be provided at adequate spacing to allow for thermal expansion of the sound barriers. For sound barriers prone to vehicular collision, relative deflection between the sound barriers on either side of an expansion joint shall be restricted.

C15.6.3

For sound barriers not utilizing post-and-panel construction, minimizing the relative deflection between the wall sections on either side of an expansion joint improves the performance of the barrier during vehicular collision near the expansion joint. This can be accomplished by installing a sliding dowel-and-sleeve connection, similar to the one shown in Figure C15.6.3-1, near the top of the wall.

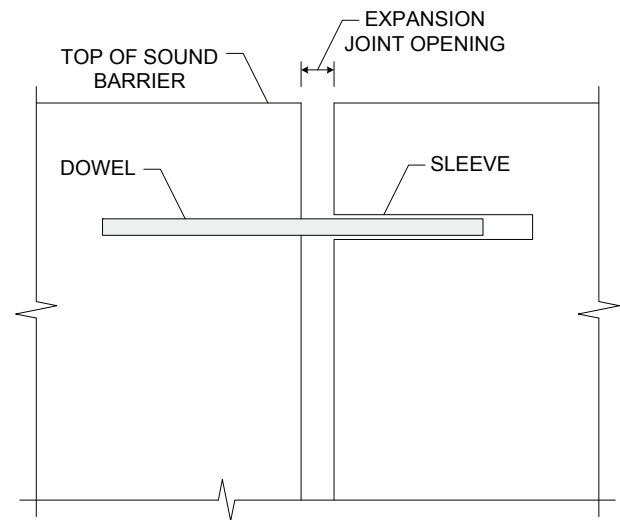

Figure C15.6.3-1—Sliding Dowel-and-Sleeve Connection

15.7—SOUND BARRIERS INSTALLED ON EXISTING BRIDGES

When sound barriers are installed on existing bridges, the effects of the sound barrier forces on existing bridge components shall be investigated, including the effect of unbalanced mass.

C15.7

Sound barrier forces transmitted to the bridge include the weight of the barrier, wind loads, seismic loads, vehicular collision forces, and any other forces that may act on the sound barriers. These forces affect railings, bridge deck overhangs, floorbeams, and girders.

When sound barriers are added on an existing bridge, the bridge should be reanalyzed to determine its load rating taking into account the forces applied to the sound barriers. The stiffening effect of the sound barriers may be considered when determining the load rating of the bridge.

15.8—LOADS

15.8.1—General

Unless explicitly modified below, all applicable loads shall be applied in accordance with the provisions of Section 3.

15.8.2—Wind Load

Except as modified below, the provisions of Article 3.8.1 shall apply.

C15.8.2

Wind load shall be applied to the entire surface of sound barriers as a uniformly distributed load. Where post-and-panel construction is utilized, the wind load effects on the posts shall be determined by applying the resultant wind loads from the uniformly loaded panels as concentrated loads to the posts at the mid-height elevation of the exposed portion of the sound barrier.

For sound barriers, wind velocity at 30.0 ft above low ground or above design water level, V_{30} , shall be taken as 1.07 times the wind velocity at the sound barrier location determined from Figure 15.8.2-1.

For sound barriers, the factors V_o and Z_o shall be taken from Table 15.8.2-1.

The wind velocities in Figure 15.8.2-1 have a 50-yr return period. The 1.07 multiplier is meant to convert the wind speed return period from the 50-yr period that Figure 15.8.2-1 is based on to a 75-yr return period to be consistent with the design life span assumed in these Specifications.

The *Guide Specifications for Structural Design of Sound Barriers* (1989) included four upstream surface conditions; B1, B2, C, and D; based on a limited study by Washington State Department of Transportation (2006). Upstream Surface Conditions B1 and C are approximately equivalent to the Suburban and Country upstream surface conditions shown in Table 3.8.1.1-1 and described in Article C3.8.1.1. The description of these categories is repeated below. Table 15.8.2-1 includes two upstream surface conditions, designated as Sparse Suburban and Coastal, that do not exist in Table 3.8.1.1-1. The values of V_o and Z_o for these two upstream surface conditions were selected to yield wind pressures approximately equal to those obtained for Upstream Surface Conditions B2 and D in the *Guide Specifications for Structural Design of Sound Barriers* (1989).

- Coastal—Flat, unobstructed areas and water surfaces directly exposed to wind. This category includes large bodies of water, smooth mud flats, salt flats, and unbroken ice.
- Open Country—Open terrain with scattered obstructions having heights generally less than 30.0 ft. This category includes flat open country and grasslands.
- Sparse Suburban—Areas with fewer obstructions than described for Suburban conditions but still more than described for Open Country conditions.
- Suburban—Urban and suburban areas, wooded areas, or other terrain with numerous closely spaced obstructions having the size of single-family or larger dwellings. Use of this category shall be limited to those areas for which representative terrain prevails in the upwind direction at least 1,500 ft.
- City—Large city centers with at least 50 percent of the buildings having a height in excess of 70.0 ft. Use of this category shall be limited to those areas for which representative terrain prevails in the upwind direction at least one-half mile. Possible channeling effects of increased velocity pressures due to the bridge or structure's location in the wake of adjacent structures shall be taken into account.

Wind loads on structure-mounted sound barriers located in areas that can be characterized as City, Suburban, Sparse Suburban, and Open Country shall be determined using the values for V_0 and Z_0 specified for Open Country conditions in Table 15.8.2-1.

Typically, the collapse of structure-mounted sound barriers poses higher danger to life and property than ground-mounted sound barriers. Therefore, in areas with low wind pressure, structure-mounted sound barriers are designed to a higher minimum wind load than ground-mounted sound barriers having the same upwind surface characteristics. This is accomplished by designing structure-mounted sound barriers to Open Country conditions as a minimum.

Table 15.8.2-1—Values of V_0 and Z_0 for Various Upstream Surface Conditions

Condition	Coastal	Open Country	Sparse Suburban	Suburban	City
V_0 (mph)	7	8.20	9.4	10.90	12.00
Z_0 (ft)	0.025	0.23	0.98	3.28	8.20

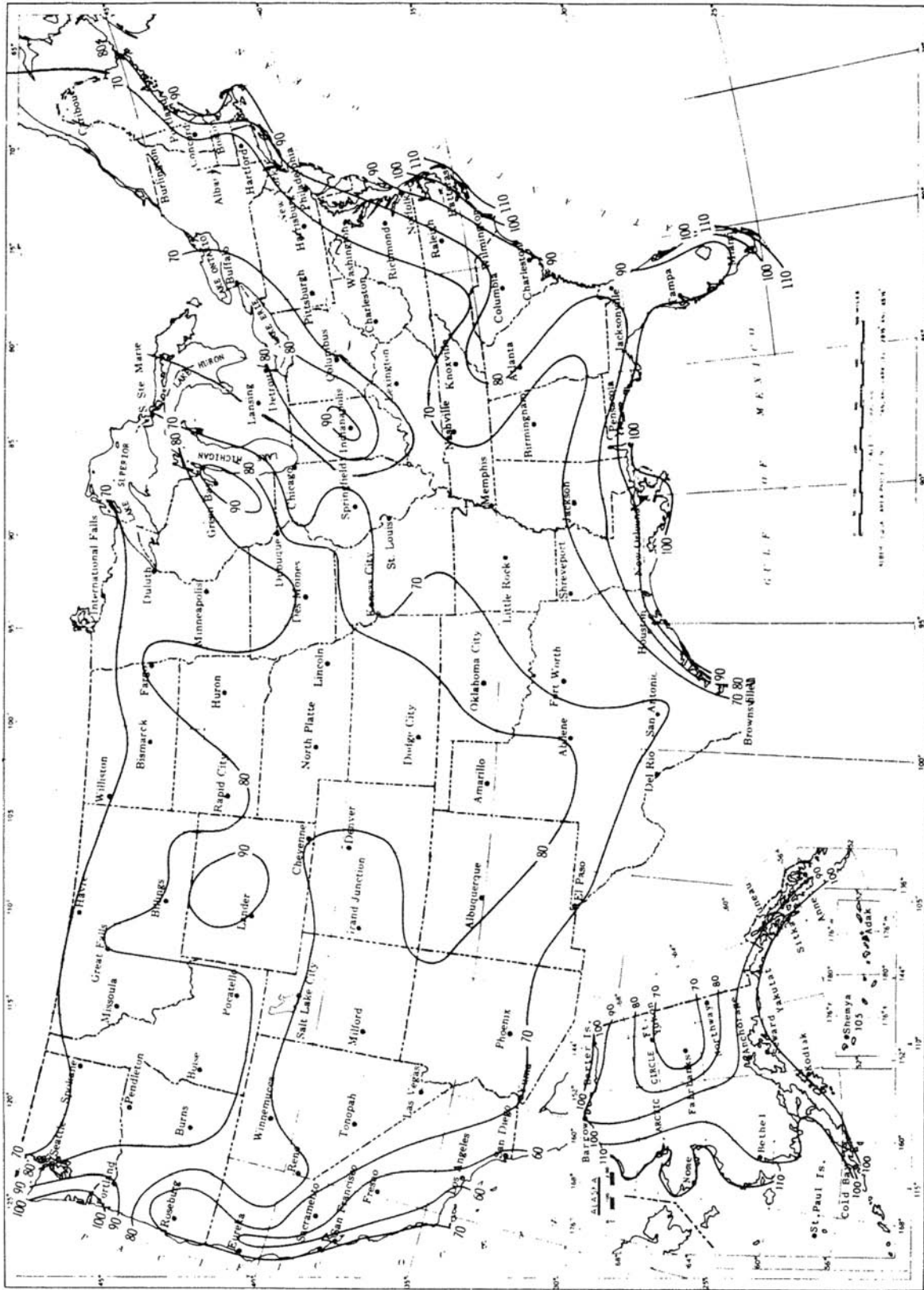

Figure 15.8.2-1—Isotach .02 quantiles, in mph: Annual extreme-mile 30.0 ft above ground, 50 yr mean recurrence intervals

15.8.3—Earth Load

The provisions of Article 3.11 shall apply.

The possibility of difference between the actual finished grade and that shown on the contract documents should be considered in the design.

15.8.4—Vehicular Collision Forces

Sound barrier systems consisting of a traffic railing and a sound barrier that have been successfully crash-tested may be used with no further analysis.

The depth of aesthetic treatments into the traffic face of sound barrier that may be subjected to vehicular collision shall be kept to a minimum.

Sound barrier materials shall be selected to limit shattering of the sound barrier during vehicular collision.

In lieu of crash-testing, the resistance of components and connections to Extreme Event II force effects may be determined based on a controlled failure scenario with a load path and sacrificial elements selected to ensure desirable performance of a structural system containing the soundwall. Vehicular collision forces shall be applied to sound barriers located within the clear zone as follows:

Case 1: For sound barriers on a crashworthy traffic railing and for sound barriers mounted behind a crashworthy traffic railing with a sound barrier setback no more than 1.0 ft: vehicular collision forces specified in Section 13 shall be applied to the sound barrier at a point 4.0 ft above the surface of the pavement in front of the traffic railing for Test Levels 3 and lower and 6.0 ft above the surface of the pavement in front of the traffic railing for Test Levels 4 and higher.

Case 2: For sound barriers behind a crashworthy traffic railing with a sound barrier setback of 4.0 ft: vehicular collision force of 4.0 kips shall be

C15.8.3

Article 3.11.5.10 contains specific requirements for the determination of earth pressure on sound barrier foundation components.

Soil build-up against sound barriers has been observed in some locations. Owners may determine the earth loads for the worst load case assuming an allowance in the finished grade elevation.

C15.8.4

Minimizing the depth of aesthetic treatment into the traffic face of sound barriers that may be in contact with a vehicle during a collision reduces the possibility of vehicle snagging.

Sound barrier systems may contain sacrificial components or components that could need repair after vehicular collision. Limiting shattering of sound barriers is particularly important for sound barriers mounted on bridges crossing over other traffic. When reinforced concrete panels are utilized for structure-mounted sound barriers, it is recommended that two mats of reinforcement are used to reduce the possibility of the concrete shattering during vehicular collision. Restraint cables placed in the middle of concrete panels may be used to reduce shattering while avoiding the increased panel thickness required to accommodate two layers of reinforcement.

The bridge overhang or moment slabs need not to be designed for more force effects than the resistance of the base connection of the sound barrier.

The design strategy involving a controlled failure scenario is similar in concept to the use of capacity protected design to resist seismic forces. Some damage to the soundwall, traffic barrier, or connections is often preferable to designing an overhang or moment slab for force effects due to vehicular collision. The bridge overhang or moment slabs need not be designed for more force effects than the resistance of the base connection of the sound barriers.

Some guidance on desirable structural performance of sound barriers can be found in European Standard EN1794-2 (2003).

Very limited information is available on crash-testing of sound barrier systems. The requirements of this Article, including the magnitude of collision forces, are mostly based on engineering judgment and observations made during crash-testing of traffic railings without sound barriers.

In the absence of crash test results for sound barrier systems, sound barriers that have not been crash-tested are often used in conjunction with vehicular railings that have been crash-tested as stand-alone railings, i.e. without sound barriers. The collision forces specified

applied. The collision force shall be assumed to act at a point 4.0 ft above the surface of the pavement in front of the traffic railing for Test Levels 3 and lower and 14.0 ft above the surface of the pavement in front of the traffic railing for Test Levels 4 and higher.

Case 3: For sound barriers behind a crashworthy traffic railing with a sound barrier setback between 1.0 ft and 4.0 ft: vehicular collision forces and the point of application of the force shall vary linearly between their values and locations specified in Case 1 and Case 2 above.

Case 4: For sound barriers behind a crashworthy traffic railing with a sound barrier setback more than 4.0 ft: vehicular collision forces need not be considered.

herein are meant to be applied to the sound barriers portion of such systems.

Crash Test Levels 3 and lower are performed using small automobiles and pick-up trucks. Crash Test Levels 4 and higher include single unit, tractor trailer trucks, or both. The difference in height of the two groups of vehicles is the reason the location of the collision force is different for the two groups of sound barriers.

For crash Test Levels 3 and lower, the point of application of the collision force on the sound barriers is assumed to be always 4.0 ft above the pavement.

During crash-testing of traffic railings for crash Test Level 4 and higher, trucks tend to tilt above the top of the railing and the top of the truck cargo box may reach approximately 4.0 ft behind the traffic face of the traffic railing. For such systems, the point of application of the collision force is expected to be as high as the height of the cargo box of a truck, assumed to be 14.0 ft above the pavement surface.

For sound barriers mounted on crashworthy traffic barriers or with a small setback assumed to be less than 1.0 ft, the full crash force is expected to act on the sound barrier. The point of application of this force is assumed to be at the level of the cargo bed, taken as 6.0 ft above the surface of the pavement.

For a sound barrier mounted with a setback more than 1.0 ft behind the traffic face of the traffic railing, it is expected that the truck cargo box, not the cargo bed, will impact the sound barrier. It is expected that the top of the cargo box will touch the sound barrier first. Due to the soft construction of cargo boxes, it is assumed that they will be crushed and will soften the collision with the sound barrier. The depth of the crushed area will increase with the increase of the collision force, thus lowering the location of the resultant of the collision force. The magnitude of the collision force and the degree to which the cargo box is crushed are expected to decrease as the setback of the sound barrier increases.

In the absence of test results, it is assumed that a collision force of 4.0 kips will develop at the top of the cargo box when it impacts sound barriers mounted with a setback of 4.0 ft.

The collision force and the point of application are assumed to vary linearly as the sound barrier setback varies between 1.0 ft and 4.0 ft.

The setback of the sound barrier, S , shall be taken as shown in Figure 15.8.4-1.

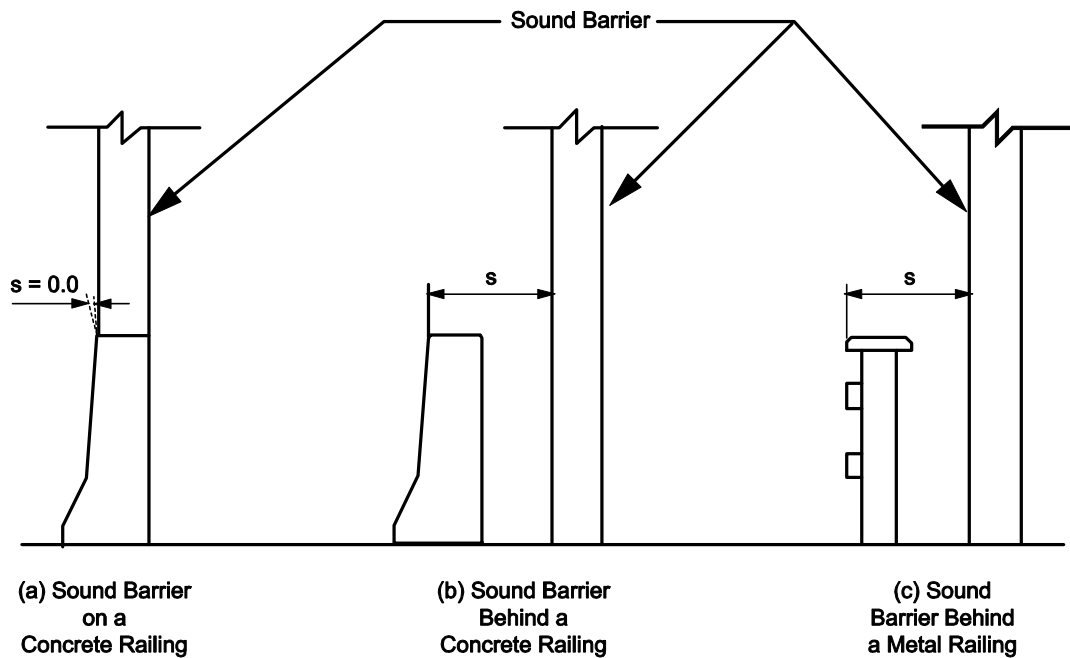

Figure 15.8.4-1—Sound Barrier Setback Distance

Collision forces on sound barriers shall be applied as a line load with a length equal to the longitudinal length of distribution of collision forces, L_s , specified in Appendix A13.

For sound barriers prone to vehicular collision forces, the wall panels and posts and the post connections to the supporting traffic barriers or footings shall be designed to resist the vehicular collision forces at the Extreme Event II limit state.

For post-and-panel construction, the design collision force for the wall panels shall be the full specified collision force placed on one panel between two posts at the location that maximizes the load effect being checked. For posts and post connections to the supporting components, the design collision force shall be the full specified collision force applied at the point of application specified in Cases 1 through 3 above.

The vehicular railing part of the sound barrier/railing system does not need to satisfy any additional requirements beyond the requirements specified in Section 13 of the Specifications for the stand-alone railings, including the height and resistance requirements.

Unless otherwise specified by the Owner, vehicular collision forces shall be considered in the design of sound barriers.

In some cases, the wall panel is divided into a series of horizontal elements. In these situations, each horizontal strip should be designed for the full design force.

Owners may select to ignore vehicular collision forces in the design of sound barriers at locations where the collapse of the sound barrier or portions of thereof has minimal safety consequences.

15.9—FOUNDATION DESIGN

15.9.1—General

Unless otherwise specified by the Owner, the geotechnical resistance of materials supporting sound barrier foundations shall be estimated using the procedures presented in Article 10.6 for spread footings, Article 10.7 for driven piles, and Article 10.8 for drilled shafts.

15.9.2—Determination of Soil and Rock Properties

The provisions of Articles 2.4 and 10.4 shall apply.

15.9.3—Limit States

Sound barriers shall be designed to withstand lateral wind and earth pressures, self weight of the wall, vehicular collision loads, and earthquake loads in accordance with the general principles specified in this Section and in Sections 10 and 11.

Sound barriers shall be investigated for vertical and lateral displacement and for overall stability at the Service I Limit State. Tolerable deformation criteria shall be developed based on maintaining the required barrier functionality, achieving the anticipated service life, and the consequences of unacceptable movements.

Sound barrier foundations shall be investigated at the strength limit states using Eq. 1.3.2.1-1 for:

- Bearing-resistance failure,
- Overall stability, and
- Structural failure.

Sound barrier foundations shall be investigated at the extreme event limit states using the applicable load combinations and load factors specified in Table 3.4.1-1.

15.9.4—Resistance Requirements

The factored resistance, R_R , calculated for each applicable limit state shall be the nominal resistance, R_n , multiplied by an appropriate resistance factor, ϕ , specified in Articles 10.5.5.1, 10.5.5.2, 10.5.5.3, 11.5.6, or 11.5.7.

C15.9.1

Although sound barriers may be supported on spread footing or driven pile foundations, drilled shafts are more commonly used because drilled shafts facilitate controlling the vertical alignment of sound barrier structural wall supports and the lateral spacing between them.

C15.9.4

Procedures for calculating nominal geotechnical resistance of footings, driven piles, and drilled shafts are provided in Articles 10.6, 10.7, and 10.8. These methods are generally accepted for barriers supported on spread footings or footings on two or more rows of driven piles or drilled shafts. The nominal geotechnical resistance of a single row of driven piles or drilled shafts or by a continuous embedded foundation wall (commonly referred to as a “trench footing”) is more appropriately calculated using the provisions in Article 11.8 for nongravity cantilever walls.

Procedures for calculating nominal structural resistance for concrete and steel components are provided in Sections 5 and 6.

15.9.5—Resistance Factors

The resistance factors for geotechnical design of foundations shall be as specified in Table 10.5.5.2.2-1 for spread footing foundations, Table 10.5.5.2.3-1 for driven pile foundations, Table 10.5.5.2.4-1 for drilled shaft foundations, and Table 11.5.7-1 for permanent retaining walls.

If methods other than those prescribed in these Specifications are used to estimate geotechnical resistance, the resistance factors chosen shall provide reliability equal or greater than those given in Tables 10.5.5.2.2-1, 10.5.5.2.3-1, 10.5.5.2.4-1, and 11.5.7-1.

15.9.6—Loading

The provisions of Section 3, as modified by Article 15.8, shall apply.

15.9.7—Movement and Stability at the Service Limit State**15.9.7.1—Movement**

The provisions of Articles 10.6.2, 10.7.2, 10.8.2, or 11.8.3, as appropriate, shall apply.

15.9.7.2—Overall Stability

The provisions of Article 11.6.2.3 shall apply.

15.9.8—Safety against Geotechnical Failure at the Strength Limit State

Spread footings or footings supported on two or more rows of driven piles or drilled shafts shall be designed in accordance with the provisions of Articles 10.6.3, 10.7.3, or 10.8.3, respectively.

Footings supported on a single row of driven piles or drilled shafts or on a continuous embedded foundation wall (“trench footing”) shall be designed in accordance with the provisions of Article 11.8.4 using the earth pressure diagrams provided in Article 3.11.5.10.

15.9.9—Seismic Design

The effect of earthquake loading shall be investigated using the Extreme Event I limit state of Table 3.4.1-1 with load factor $\gamma_p = 1.0$, and an accepted methodology.

15.9.10—Corrosion Protection

The provisions of Article 11.8.7 shall apply.

15.9.11—Drainage

Where sound barriers support earth loads or can impede water flow, the provisions of Article 11.8.8 shall apply.

15.10—REFERENCES

AASHTO. 1989 with 1992 and 2002 interims. Guide Specifications for Structural Design of Sound Barriers, GSSB-1-M. American Association of State Highway and Transportation Officials, Washington, DC.

Bullard, Jr. D. L., N. M. Sheikh, R. P. Bligh, R. R. Haug, J. R. Schutt, and B. J. Storey. 2006. Aesthetic Concrete Barrier Design, NCHRP Report 554. Transportation Research Board, National Research Council, Washington, DC.

Washington State Department of Transportation. 2006. Wind Loading Comparison. Washington State Department of Transportation, Olympia, WA.

White, M., J. Jewell, and R. Peter. 2002. Crash Testing of Various Textured Barriers, FHWA/CA/TL-2002/03. California Department of Transportation, Sacramento, CA.

INDEX

- Abutments and retaining walls
 - backfill..... 11-5
 - bearing resistance 11-8, 11-15
 - conventional walls and abutments..... 11-16, 11-18
 - drainage..... 11-33
 - expansion and contraction joints 11-18
 - extreme event limit state..... 11-7
 - free-standing abutments 11-110
 - integral abutments 11-18
 - load combinations and load factors 11-10
 - loading..... 11-17
 - movement and stability 11-19
 - overturning 11-64, 11-103
 - passive resistance 11-23
 - reinforcement 11-18
 - resistance factors 11-6, 11-10
 - safety against structural failure..... 11-23
 - seismic design 11-23
 - service limit state..... 11-6, 11-19
 - sliding 11-23, 11-65, 11-102
 - strength limit state 11-7, 11-20
 - subsurface erosion 11-22
 - wingwalls 11-18
- Aeroelastic instability
 - aeroelastic phenomena 3-43
 - control of dynamic responses 3-44
 - wind tunnel tests..... 3-44
- Alkali-silica reactive aggregates..... 5-175
- Aluminum
 - minimum thickness 7-21
- Aluminum orthotropic decks
 - See: Orthotropic aluminum decks
- Anchor bolts
 - bearings 14-83
 - deck joints 14-17
- Anchorage
 - bearings 14-67, 14-82
 - deck joints 14-17
 - elastomeric bearings..... 14-63
 - footings..... 10-53
 - post-tensioned anchorage zones 5-122
 - post-tensioning 5-21
 - railings..... 13-17
 - tension ties..... 5-33
- Anchored walls..... 11-43
 - anchor pullout capacity 11-46
 - anchor stressing and testing..... 11-53
 - anchors 11-49
 - bearing resistance 11-45
 - construction and installation..... 11-53
 - corrosion protection..... 11-52
 - drainage..... 11-54
 - dynamic load allowance 3-30, 3-23
 - earth pressure..... 3-99, 3-113
 - facing..... 11-51
 - loading..... 11-44
 - movement..... 11-44
 - overall stability..... 11-45
 - passive resistance 11-49
 - safety against soil failure..... 11-45
 - safety against structural failure..... 11-49
 - seismic design 11-51
 - ultimate unit bond stress for anchors..... 11-46
 - vertical wall elements..... 11-51
- Angles
 - flexural resistance..... 6-205, 6-209
- Annual frequency of collapse
 - geometric probability 3-138, 3-141
 - probability of aberrancy 3-143
 - probability of collapse 3-147
 - vessel frequency distribution..... 3-142
- Approximate methods of analysis
 - analysis of segmental concrete bridges 4-65
 - beam-slab bridges..... 4-29
 - decks..... 4-22
 - effective flange width..... 4-54
 - effective length factor..... 4-49
 - equivalent strip widths for box culverts 4-67
 - equivalent strip widths for slab-type bridges..... 4-48
 - lateral wind load distribution in multibeam bridges..... 4-62
 - moment magnification..... 4-14, 4-15
 - orthotropic decks 9-20, 9-27
 - seismic lateral load distribution..... 4-63
 - stress analyses and design 5-137
 - truss and arch bridges..... 4-49
- Arch bridges
 - refined analysis..... 4-70
- Arch structures
 - See: Metal pipe, pipe arch, and arch structures
- Arches..... 5-231
 - aluminum structures 7-56
 - arch ribs..... 5-231
 - load distribution..... 4-49, 4-73
 - moment magnification..... 4-15
 - steel, diaphragms..... 6-60
- Backfill
 - See: Abutments and retaining walls
- Barriers
 - See: Railings
- Basic requirements of structural dynamics
 - damping..... 4-77
 - distribution of masses 4-77
 - natural frequencies 4-77
 - stiffness 4-77
- Batter piles..... 10-82
- Beam columns
 - moment magnification..... 4-14
- Beam ledges 5-182
 - design for bearing..... 5-186
 - design for flexure and horizontal force 5-184

design of hanger reinforcement	5-185	special design provisions	14-42
design for punching shear	5-184	tapered plates	14-83
design for shear	5-183	Bicycle railings	13-11
Beam-slab bridges		design live loads	13-11
application	4-29	geometry	13-11
distribution factor method for moment		Bolted connections	6-214
and shear	4-35	See also: Bolted splices, Bolts	
distribution factor method for shear	4-42	bearing resistance at fastener holes	7-53
refined methods of analysis	4-68	bearing-type	6-215
special loads with other traffic	4-47	block shear or end rupture	7-54
Bearing area		bolts and nuts	7-50
concrete	5-57	combined tension and shear	6-226
Bearing pressure		edge distance	6-220, 7-52
spread footings	10-52	end distance	6-219, 7-52
Bearing resistance		factored resistance	6-215
abutments and retaining walls	11-10, 11-20	holes	6-217
anchored walls	11-45	maximum pitch for sealing fasteners	7-51
buried structures	12-18	maximum pitch for stitch bolts	6-219
fastener holes	7-53	maximum pitch for stitch fasteners	7-52
flat surfaces and pins	7-53	maximum spacing for sealing bolts	6-218
MSE walls	11-64	minimum edge distance	6-220
prefabricated modular walls	11-102	minimum pitch and clear distance	7-51
reinforced concrete pipe	12-61	minimum spacing and clear distance	6-218
at rivet and bolt holes	7-53	nuts	6-26
spread footings	10-64	shear resistance	6-220
Bearing stiffeners	6-165	shear resistance of fasteners	7-52
axial resistance	6-166	size of fasteners	7-51
bearing resistance	6-165	slip-critical	6-214
projecting width	6-165	slip-critical connections	7-53
steel	6-285	slip resistance	6-221
Bearings	14-1	spacing of fasteners	7-51
See also: Disc bearings, Elastomeric		stitch fasteners at the end of compression	
bearings, Pot bearings		members	7-52
anchor bolts	14-82	tension	7-53
applicability	14-40	washers	6-26, 6-216
bearing resistance	14-49	Bolted splices	
bronze or copper alloy sliding surfaces	14-76	compression members	6-233
characteristics	14-36	fillers	6-241
corrosion protection	14-84	flange splices	6-238
curved sliding surfaces	14-12, 14-49	flexural members	6-233
design criteria	14-41	tension members	6-232
design requirements	14-10	web splices	6-243
fabrication, installation, testing, and		welded splices	6-242
shipping	14-40	Bolts	
force effects resulting from restraint of		bearing resistance	6-224
movement at the bearing	14-37	materials	6-25
guides and restraints	14-79	minimum required bolt tension	6-221
horizontal force and movement	14-37	prying action	6-225
launching	5-211, 5-228, 5-232	size	6-218
metal rocker and roller bearings	14-42	spacing	6-218
moment	14-38	tensile resistance	6-225
movements and loads	14-6	Boundary conditions	
other bearing systems	14-81	mathematical modeling	4-10
plates for load distribution	14-82	Box culverts	
PTFE sliding surfaces	14-44	equivalent strip widths	4-67
resistance to lateral load	14-50	live loads	3-27, 4-27
seismic design	14-84	Box girders	
seismic provisions	14-40	effective flange width	4-54
		wind load distribution	4-62

- Bracing
 See also: Diaphragms and cross-frames,
 Lateral bracing
 box sections 4-63
 glued laminated timber girders 8-37
 portal bracing 6-246, 7-56
 sawn wood beams 8-36
 sway bracing 6-246, 7-56
 trusses 6-246, 8-37
- Brackets and corbels 5-179
 alternative to strut-and-tie model 5-181
- Braking force 3-32
- Bridge aesthetics 2-16
- Bridge joints
 See: Deck joints
- Bridge scour
 See: Scour
- Bridge site arrangement 2-4
 traffic safety 2-4
- Bridge testing 4-90
- Bridges composed of simple span precast
 girders made continuous 5-201
 age of girder when continuity is
 established 5-203
 continuity diaphragms 5-209
 degree of continuity at various limit states 5-204
 material properties 5-203
 negative moment connections 5-206
 positive moment connections 5-206
 restraint moments 5-202
 service limit state 5-205
 strength limit state 5-206
- Bronze or copper alloy sliding surfaces 14-76
 clearances and mating surfaces 14-77
 coefficient of friction 14-77
 limit on load 14-77
 materials 14-76
- Builtup members 6-78
 perforated plates 6-78
- Bundled reinforcement
 development length 5-162
 number of bars in a bundle 5-112
 spacing 5-112
 ties 5-120
- Buried structures
 bearing resistance and stability 12-18
 corner backfill for metal pipe arches 12-19
 corrosive and abrasive conditions 12-23
 cross-section properties 12-91
 differential settlement between structure
 and backfill 12-14
 embankment installations 12-19
 end treatment 12-22
 flexibility limits and construction
 stiffness 12-13
 flexible culverts constructed on skew 12-22
 footing settlement 12-14
 hydraulic design 12-19
 load modifiers and load factors 12-9
 loading 12-13
 longitudinal differential settlement 12-14
 mechanical properties 12-73
 minimum longitudinal seam strength
 12-90, 12-100, 12-101, 12-103
 minimum soil cover 12-20
 minimum spacing between multiple lines
 of pipe 12-21
 resistance factors 12-10
 safety against soil failure 12-18
 scour 12-19
 service limit state 12-9, 12-14
 settlement 12-14
 soil envelope 12-19
 strength limit state 12-9
 tolerable movement 12-14
 trench installations 12-19
 unbalanced loading 12-15
 uplift 12-18
- Cable-stayed bridges
 refined analysis 4-72
- Cables
 bridge strand 6-29
 bright wire 6-28
 epoxy-coated wire 6-29
 galvanized wire 6-28
- Caissons.
 See: Drilled shafts
- Camber
 aluminum structures 7-18
 glued laminated timber girders 8-37
 heat-curved rolled beams and welded
 plate girders 6-70, 6-71
 steel structures 6-57
 stress laminated timber deck bridge 8-37
 trusses 6-245, 8-37
- Cantilever slabs
 design 9-8
 segmental construction 5-211
 wheel load position 3-25
- Cantilevered retaining walls 11-34
 corrosion protection 11-42
 drainage 11-43
 earth pressure 3-99
 facing 11-36
 loading 11-34
 movement 11-34
 overall stability 11-35
 safety against soil failure 11-35
 safety against structural failure 11-36
 seismic design 11-38
 vertical wall elements 11-36
- Cast-in-place box culverts and arches 12-65
 cast-in-place structures 12-70
 construction and installation 12-71
 design moment for box culverts 12-70
 distribution of concentrated loads in
 skewed box culverts 12-69

distribution of concentrated loads to		Combined force effects	
bottom slab of culvert.....	12-69	aluminum.....	7-48
earth load modification.....	12-66	Compact sections	
embankment and trench conditions.....	12-66	nominal flexural resistance.....	6-136, 6-187
loads and live load distribution.....	12-66	Composite box girders	
minimum cover for precast box		See also: Box girders	
structures.....	12-71	diaphragms.....	6-59
minimum reinforcement.....	12-71	fatigue.....	6-157
other installations.....	12-69	lateral bracing.....	6-65
precast box structures.....	12-70	wind effects.....	4-79
safety against structural failure.....	12-70	Composite sections	
service limit state.....	12-69	aluminum.....	7-19
soil-structure interaction.....	12-66	concrete-encased shapes.....	6-99, 6-212
Cast-in-place girders and box and T-beams		concrete-filled tubes.....	6-99, 6-212, 6-213
bottom flange.....	5-210	nominal shear resistance.....	6-212
bottom slab reinforcement in box girders.....	5-211	sequence of loading.....	6-102
deck slab reinforcement cast-in-place in		steel.....	6-102
T-beams and box girders.....	5-210	stresses.....	6-102
effective flange width.....	4-54, 4-55	Compression flange flexural resistance..	6-142, 6-284
flange and web thickness.....	5-210	lateral torsional buckling resistance..	6-144, 6-279
reinforcement.....	5-210	local buckling resistance.....	6-143, 6-278
top flange.....	5-210	Compression flange proportions.....	6-196
web.....	5-210	Compression members	
Cast-in-place piles		aluminum.....	7-24
See: Concrete piles		axial resistance.....	5-51
Cast-in-place solid slab superstructures.....	5-231	biaxial flexure.....	5-52
Cast-in-place voided slab superstructures.....	5-232	compressive resistance.....	6-77
compressive zones in negative moment		concrete.....	5-53
area.....	5-234	hollow rectangular.....	5-38, 5-53, 5-54
cross-section dimensions.....	5-232	limiting slenderness ratio.....	6-81
drainage of voids.....	5-234	splices.....	7-54
general design requirements.....	5-233	steel composite members.....	6-98
minimum number of bearings.....	5-233	steel noncomposite members.....	6-82
solid end sections.....	5-233	subjected to torsion.....	7-45
Cast metal		wood.....	8-33
cast iron.....	6-28	Compressive resistance	
cast steel and ductile iron.....	6-28	aluminum.....	7-26, 7-27, 7-29, 7-31, 7-35
malleable castings.....	6-28	axial compression.....	6-81
Cellular and box bridges		combined axial compression and flexure.....	6-81
refined analysis.....	4-72	concrete.....	5-53
Centrifugal forces.....	3-32	steel.....	6-81
Charpy V-notch test		steel composite members.....	6-98
requirements.....	6-48	steel noncomposite members.....	6-82
temperature zones.....	6-49	steel piles.....	6-252
Clearances		Compressive struts	
drilled shafts.....	10-124	effective cross-sectional area of strut.....	5-32
highway horizontal.....	2-6	limiting compressive stress in strut.....	5-33
highway vertical.....	2-6	reinforced strut.....	5-33
navigational.....	2-6	strength of unreinforced strut.....	5-31
piles.....	10-81	Concrete	
railroad overpass.....	2-6	basic steps for concrete bridges.....	5-247
Coefficient of thermal expansion		classes.....	5-13
concrete.....	5-15	coefficient of thermal expansion.....	5-15
Collision force		cohesion factor.....	5-83
See: Vehicular collision force, Vessel		compressive strength.....	5-13
collisions		creep.....	5-15
Combination railings.....	13-12	effects of imposed deformation.....	5-29
design live loads.....	13-12	friction factor.....	5-82
geometry.....	13-12	modulus of elasticity.....	5-21

- modulus of rupture 5-18
- Poisson's ratio 5-18
- properties 5-20
- shrinkage 3-133
- strut-and-tie model 5-29
- tensile strength 5-18
- unit weight 3-16
- Concrete box girders
 - bridges composed of simple span precast
 - girders made continuous 5-201
 - cross-section dimensions and details 5-220
 - effective flange width 4-54
 - girder segment design 5-200
 - joints between segments 5-205
 - length of top flange cantilever 5-199
 - live load distribution factors 4-30
 - minimum flange thickness 5-220
 - minimum web thickness 5-220
 - overlays 5-222
 - post-tensioning 5-201
 - prestress losses 5-105
 - spliced precast girders 5-198, 5-200
 - torsional resistance 5-77
- Concrete deck slabs
 - See: Concrete slabs
- Concrete formwork
 - bedding of panels 9-14
 - creep and shrinkage control 9-14
 - depth 9-13
 - reinforcement 9-14
- Concrete piles 5-192
 - cast-in-place piles 5-194
 - pile dimensions 5-192
 - precast prestressed 5-192
 - precast reinforced 5-192
 - reinforcing steel 5-192
 - seismic requirements 5-194
 - splices 5-112
 - structural resistance 10-117
- Concrete slabs
 - application of empirical design 9-9
 - composite action 9-7
 - design conditions 9-10
 - design of cantilever slabs 9-8
 - distribution reinforcement 9-12
 - edge support 9-8
 - effective length 9-9
 - empirical design 9-8
 - minimum depth and cover 9-7
 - precast deck slabs on girders 9-14
 - reinforcement requirements 9-11
 - segmental construction 9-15
 - shear 5-57
 - skewed bridges 4-40
 - skewed decks 9-7
 - stay-in-place formwork 9-12
 - traditional design 9-12
- Concrete stress limits
 - partially prestressed components 5-98
 - service limit state after losses 5-95
 - temporary stresses before losses 5-93
- Connections
 - See also: Bolted connections, Splices, Welded connections
 - block shear or end rupture 7-54
 - block shear rupture resistance 6-230
 - elements 6-231
 - rigid frame 6-243
 - rigid frame connections 6-243
- Constructibility 6-120, 6-179
 - dead load deflections 6-126
 - deck placement 6-124
 - design objectives 2-7, 2-20
 - flexure 6-121, 6-179
 - shear 6-124, 6-182
- Continuous beam bridges
 - approximate method of analysis 4-22
 - refined method of analysis 4-68
- Continuously braced flanges in tension 6-190
- Continuously braced flanges in tension or compression 6-123, 6-141
- Corrosion
 - buried structures 12-23
 - piles 10-119
- Corrosion protection
 - alternative coating 8-23
 - anchored walls 11-52
 - bearings 14-84
 - cantilevered retaining walls 11-42
 - metallic coating 8-23
- Corrugated metal decks
 - composite action 9-30
 - distribution of wheel loads 9-30
- Cover plates 6-170
 - end requirements 6-170
 - yield moment 6-317
- Creep effect 3-135, 5-15
- Cross-frames
 - See: Diaphragms and cross-frames
- Cross-section proportion limits
 - flange proportions 6-119, 6-178
 - special restrictions on use of live load
 - distribution factor for multiple box sections 6-178
 - web proportions 6-118, 6-177
- Culverts
 - See also: Long-span structural plate structures
 - design for flexure 5-236
 - design for shear in slabs of box culverts 5-236
 - live loads 3-25
 - location, length, and waterway area 2-23
 - segmental construction 5-211
- Curbs 13-12
 - end treatment of separation railing 13-13
- Curved structures
 - concrete cover, prestressing tendons 5-118
 - multicell concrete box girders 4-32

multiple beam superstructures	4-20	Deck overhang load	3-28
single girder superstructures	4-18	Decks	
torsionally stiff superstructures	4-18	See also: Deck joints, Deck overhang	
Curved tendons		design	
effects of curved tendons	5-114	applicability	4-22
in-plane force effects	5-115	concrete appurtenances	9-5
out-of-plane force effects	5-118	cross-sectional frame action	4-27
Dead loads		deck drainage	9-4
load factors	3-16	distribution of wheel loads	4-26
MSE walls	11-96	edge supports	9-5
steel structures	6-57, 6-126	edges of slabs	4-25
unit weight of materials	3-7	equivalent strips	4-23
Deck analysis		force effects	4-24
deck slab design table	4-97	inelastic analysis	4-29
loading	9-6	interface action	9-4
methods	4-22	live load effects on grids	4-27
methods of analysis	9-6	live loads	3-25
Deck joints		longitudinal edges	4-25
adjustment	14-18	stay-in-place formwork	9-5
anchors	14-17	transverse edges	4-25
armor	14-17	Deep beams	
bolts	14-18	detailing requirements	5-178
bridging plates	14-17	Deflection	
closed joints	14-20	aluminum	7-9
compression and cellular seals	14-21	criteria	2-11
design requirements	14-10, 14-15	Deformations	
fabrication	14-18	axial	5-48
field splices	14-19	concrete	5-59
geometry	14-14	criteria for deflection	2-11
installation	14-18	criteria for span-to-depth ratios	2-13
joint seals	14-20	force effects due to superimposed	
location	14-15	deformations	3-133
maintenance	14-14	permanent	6-127
materials	14-14	steel	6-127
modular bridge joint systems	14-22	Deformed bars and deformed wire in tension	
movements and loads	14-6	tension development length	5-160
movements during construction	14-15	Deformed bars in compression	
movements in service	14-16	compressive development length	5-162
number of joints	14-14	modification factors	5-162
open joints	14-19	Depth of the web in compression	
plank seals	14-22	in the elastic range	6-317
poured seals	14-21	at plastic moment	6-318
protection	14-16	Design lane load	3-24
requirements	14-12	Design lanes	
segmental construction	9-15	number of	3-17
selection	14-14	Design objectives	
sheet and strip seals	14-21	bridge aesthetics	2-16
specific joint type considerations	14-19	constructibility	2-14
structural design	14-13	economy	2-15
temporary supports	14-19	safety	2-7
waterproofed joints	14-20	serviceability	2-8
Deck overhang design	13-25	Design philosophy	
decks supporting concrete parapet		ductility	1-5
railings	13-25	limit states	1-3
decks supporting post-and-beam railings	13-26	operational importance	1-7
design cases	13-25	redundancy	1-6
overhang design	13-26		
resistance to punching shear	13-27		
stay-in-place formwork	9-5		

- Design tandem 3-24
- Design truck 3-23
- Design vessel 3-138
- Development of reinforcement
- basic requirements 5-157
 - bonded strand 5-168
 - bundled bars 5-112
 - deformed bars and deformed wire in
 - tension 5-160
 - deformed bars in compression 5-162
 - development by mechanical anchorages 5-167
 - flexural reinforcement 5-167
 - footings 5-187
 - modification factors 5-161, 5-162, 5-163
 - partially debonded strands 5-169
 - prestressing strand 5-166
 - shear reinforcement 5-185
 - standard hooks in tension 5-163
 - welded wire fabric 5-164
- Diaphragms and cross-frames 6-59
- aluminum structures 7-21
 - concrete structures 5-174, 5-211, 5-220
 - orthotropic deck superstructures 6-247
 - steel arches 6-64
 - steel box section members 6-62
 - steel I-section members 6-60
 - steel trusses 6-64, 6-246
- Disc bearings 14-77
- See also: Bearings
- elastomeric disc 14-78
 - materials 14-78
 - movements and loads 14-12
 - shear resistance mechanism 14-79
 - steel plates 14-79
- Distortion-induced fatigue 7-17
- lateral connection plates 6-52, 7-18
 - orthotropic decks 6-53
 - transverse connection plates 6-52, 7-18
- Distribution of load
- concrete slabs 4-27
 - curved steel bridges 4-46
 - exterior beams 4-39, 4-44, 4-46
 - interior beams 4-35, 4-38, 4-42, 4-46
 - skewed bridges 4-40, 4-46
 - wheel loads through earth fills 3-25
- Dowels
- concrete columns 5-187
- Downdrag 3-131, 10-83, 10-89, 10-95, 10-128,
..... 10-126, 10-130, 10-147, 10-148
- Drainage
- See also: Roadway drainage
- abutments and retaining walls 11-33
 - anchored walls 11-54
 - cantilevered retaining walls 11-43
 - cast-in-place voided slab superstructures 5-232
 - MSE walls 11-94
 - prefabricated modular walls 11-105
 - sound barrier 15-2, 15-14
 - steel box-section flexural members 6-177
- Drilled shafts 10-123
- battered shafts 10-124
 - buckling 10-143
 - clearance 10-124
 - combined side and tip resistance 10-138
 - concrete 10-144
 - diameter 10-124
 - downdrag 10-126, 10-130
 - embedment 10-124
 - enlarged bases 10-124, 10-144
 - extreme event limit state 10-144
 - groundwater table and buoyancy 10-130
 - group resistance 10-140
 - horizontal movement 10-130
 - horizontal resistance 10-143
 - lateral squeeze 10-130
 - lateral stability 10-143
 - load test 10-139
 - reinforcement 10-143, 10-144
 - resistance in cohesionless soils 10-134, 10-140
 - resistance in cohesive soils 10-131, 10-141
 - resistance in rock 10-136
 - scour 10-130
 - service limit state 10-126
 - settlement 10-126, 10-130
 - shaft loads 10-126
 - shaft resistance 10-125
 - shaft resistance in intermediate geo
 - materials 10-139
 - shafts in strong soil overlying weaker
 - compressible soil 10-136
 - side resistance 10-132, 10-134, 10-137
 - spacing 10-124
 - strength limit state 10-130
 - structural resistance 10-143
 - tip resistance 10-133, 10-135, 10-138
 - tolerable movements 10-126
 - transverse reinforcement 10-144
 - uplift 10-126
 - uplift resistance 10-142
- Driven piles
- See: Piles
- Ductility 1-5
- Ductility requirements
- steel I-section flexural members 6-140
- Ducts
- at deviation saddles 5-23
 - size of 5-22
 - spacing 5-112, 5-113
- Durability 5-174
- alkali-silica reactive aggregates 5-175
 - concrete cover 5-175
 - materials 2-8
 - protection for prestressing tendons 5-176
 - protective coatings 5-176
 - self-protecting measures 2-8
- Dynamic analysis
- Analysis of blast effects 4-90
 - analysis for collision loads 4-90

analysis for earthquake loads.....	4-77	compressive stress	14-70
basic requirements	4-79	design method A	14-67
elastic dynamic responses.....	4-76	design method B	14-56
inelastic dynamic responses.....	4-80	extreme event provisions	14-66, 14-75
Dynamic load allowance		material properties	14-58, 14-69
buried components.....	3-31	movements and loads.....	14-11
wood components	3-32	reinforcement.....	14-64, 14-75
Earth loads	3-17	rotation.....	14-73
sound barrier	15-9	seismic provisions	14-66, 14-75
Earth pressure	3-99	shear.....	14-73
active	3-103	shear deformation	14-59
anchored walls	3-113	stability	14-63, 14-75
at-rest.....	3-103	Elastomeric pads	
cantilevered walls	3-109	See: Elastomeric bearings	
compaction	3-100	Emergency responder access to sound	
downdrag	3-131	barriers.....	15-2
effect of earthquake	3-101	End requirements	
equivalent-fluid method of estimating.....	3-107	cover plates	6-170
friction angle for dissimilar materials.....	3-105	Environment	2-7
lateral earth pressure.....	3-101, 3-109	Equivalent members	
mechanically stabilized earth walls	3-116	mathematical modeling.....	4-10
passive	3-105	Erosion control.....	11-22, 11-95, 11-103
prefabricated modular walls	3-118	Existing bridges, sound barrier installation	
presence of water	3-100	for	15-5
reduction due to earth pressure	3-131	Expansion	
surcharge loads	3-123	See: Coefficient of thermal expansion	
Earthquake effects		Expansion devices for sound barriers	15-4
See: Seismic loads		Extreme event limit states.....	1-5
Economy		abutments and retaining walls	11-7, 11-16
alternative plans.....	2-15	concrete structures	5-44
Edge distance	6-220	decks	9-6
Edge support		drilled shafts	10-144
slabs.....	9-8	foundations	10-31, 10-50
Effective area		load combinations.....	3-11, 3-13
aluminum.....	7-23	piles	10-118
steel.....	6-57	railings	13-5
welds.....	6-229	spread footings.....	10-80
Effective flange width.....	4-54	steel structures	6-31
cast-in-place multicell superstructures.....	4-59	vessel collision damage	3-138
orthotropic steel decks	4-59	wood structures.....	8-31
analysis of segmental concrete bridges.....	4-65	Eyebars	
segmental concrete box beams and single		factored resistance	6-78
cell cast-in-place box beams.....	4-55	minimum size pin for.....	6-69
Effective length		packing	6-80
columns	4-49	proportions.....	6-80
span.....	6-57, 7-19	Fasteners	
Effective plastic moment		See also: Bolts	
all other interior-pier sections.....	6-290	alternative	6-27
interior-pier sections with enhanced		shear resistance of.....	7-52
moment-rotation characteristics	6-289	spacing of.....	7-51
Elastic dynamic responses		Fatigue	
vehicle-induced vibration	4-79	distortion-induced.....	6-46
wind-induced vibration.....	4-79	load-induced	6-31
Elastic stress analysis.....	5-136	Fatigue and fracture limit states.....	1-4
Elastomeric bearings		aluminum structures	7-9
See also: Bearings		concrete structures	5-23, 5-35
combined compression, rotation, and		decks	9-6, 9-18, 9-19
shear	14-60	modular bridge joint systems.....	14-29
compressive deflection	14-65, 14-71	orthotropic aluminum decks	9-26

- prestressing tendons5-25
- reinforcing bars5-24
- steel box-section flexural members6-183
- steel I-section flexural members.....6-130
- steel structures6-29
- welded or mechanical splices of reinforcement5-25
- Fatigue design
 - cycles..... 6-49, 6-51
 - orthotropic steel decks6-83
- Fatigue load
 - approximate methods3-25
 - frequency3-29
 - load distribution for fatigue.....3-29
 - magnitude and configuration3-28
 - refined methods3-29
- Fatigue resistance
 - shear connectors6-157
- Filled and partially filled grid decks
 - design requirements.....9-17
 - fatigue and fracture limit state9-18
- Fillers
 - bolted splices6-241
- Fillet-welded connections6-228
 - size6-229
- Flange proportions.....6-178
- Flange-strength reduction factors
 - hybrid factor6-113
 - web load-shedding factor6-114
- Flexibility limits and construction stiffness
 - corrugated metal pipe and structural plate structures12-12
 - spiral rib metal pipe and pipe arches12-12
 - steel tunnel liner plate.....12-13
 - thermoplastic pipe12-13
- Flexural members
 - aluminum.....7-30
 - concrete5-39, 5-121
 - splices7-54
 - wood.....8-28, 8-31
- Flexural resistance
 - based on tension flange yielding6-282
 - based on the compression flange6-277
 - box flanges in compression6-190
 - compact sections6-136, 6-187
 - compression-flange flexural resistance6-142
 - concrete5-44
 - continuously braced flanges in tension.....6-190
 - continuously braced flanges in tension or compression6-141
 - discretely braced flanges in compression6-141
 - discretely braced flanges in tension.....6-141
 - ductility requirement6-140
 - interior-pier I-sections in straight continuous-span bridges6-286
 - lateral torsional buckling
 - resistance6-144, 6-279
 - local buckling resistance6-143, 6-278
 - noncompact sections6-139, 6-187
 - straight composite I-sections in negative flexure6-271
 - straight noncomposite I-sections with compact or noncompact webs6-271
 - tension-flange flexural resistance6-150
- Flexure
 - composite sections in negative flexure and noncomposite sections6-134
 - composite sections in positive flexure.....6-132
 - concrete deck6-123
 - continuously braced flanges in tension or compression6-123
 - discretely braced flanges in compression6-121
 - discretely braced flanges in tension.....6-123
- Footings5-187
 - development of reinforcement.....5-190
 - distribution of moment reinforcement.....5-188
 - loads and reactions5-187
 - moment in.....5-187
 - reactions5-187, 12-30
 - resistance factors5-187
 - shear in slabs and footings.....5-59, 5-188
 - transfer of force at base of column5-190
- Foundation design10-163
- Foundation investigation2-7, 10-163
 - topographic studies.....2-7
- Fracture
 - aluminum.....7-18
 - steel6-53
 - toughness requirements6-53
- Free-standing abutments
 - design for displacement.....11-120
 - Mononobe-Okabe analysis11-110
 - nonyielding abutments11-30
- Friction forces.....3-138
- General zone.....5-124
 - application of the strut-and-tie model.....5-132
 - blister and rib reinforcement5-130
 - design methods.....5-125
 - design principles.....5-126
 - deviation saddles5-132
 - diaphragms5-131
 - intermediate anchorages5-129
 - multiple slab anchorages5-131
 - responsibilities.....5-125
 - special anchorage devices5-144
 - tie-backs5-130
- Geometry
 - bicycle railings13-11
 - combination railings13-12
 - deck joints14-14
 - large deflection theory4-12
 - pedestrian railings13-9
 - small deflection theory4-12
 - traffic railings13-15
- Geophysical tests
 - soil and rock10-12
- Glued laminated decks9-32
 - deck tie-downs.....9-32

interconnected decks.....	9-32	on vehicles.....	3-42
noninterconnected decks.....	9-33	Hydraulic analysis	
Glued laminated timber		bridge foundations.....	2-20
See also: Wood		bridge waterway.....	2-20
bracing.....	8-36	roadway approaches to bridge.....	2-23
camber.....	8-37	stream stability.....	2-17
dimensions.....	8-13	Hydrology and hydraulics	
reference design values.....	8-14	culvert location, length, and waterway	
volume factor.....	8-27	area.....	2-23
Gravel		hydraulic analysis.....	2-19
unit weight.....	3-16	hydrologic analysis.....	2-18
Gravity loads		roadway drainage.....	2-24
design vehicular live load.....	3-19	site data.....	2-18
vehicular live load.....	3-17	Ice loads	
Groove-welded connections		adhesion.....	3-50
complete penetration.....	6-227	combination of forces.....	3-49
partial penetration.....	6-228	crushing and flexing.....	3-47
Grout		dynamic ice forces on piers.....	3-46
steel tunnel liner plate.....	12-88	effective ice strength.....	3-46
Guides and restraints.....	14-79	hanging dams and ice jams.....	3-50
attachment of low-friction material.....	14-81	ice accretion and snow loads on	
contact stress.....	14-81	superstructures.....	3-51
design basis.....	14-80	slender and flexible piers.....	3-50
design loads.....	14-80	small streams.....	3-48
geometric requirements.....	14-80	static ice loads on piers.....	3-50
load location.....	14-80	Idealization	
materials.....	14-80	See: Mathematical modeling	
Gusset plates.....	6-246	Impact	
Heat-curved rolled beams and welded plate		See: Dynamic load allowance	
girders camber.....	6-70	In-situ tests	
minimum radius of curvature.....	6-70	See: Soil properties	
High load multirotational (HLMR) bearings		Inelastic dynamic responses.....	4-80
curved sliding surface bearings.....	14-12	plastic hinges and yield lines.....	4-80
disc bearings.....	14-12	Influence of plan geometry	
pot bearings.....	14-12	curved structures.....	4-17
Holes		plan aspect ratio.....	4-17
long-slotted.....	6-217, 7-51	Instantaneous losses	
maximum hole size.....	6-217	anchorage set.....	5-98
oversize.....	6-217, 7-51	elastic shortening.....	5-101
short-slotted.....	6-217, 7-51	friction.....	5-99
size.....	6-217	Interaction systems	
type.....	6-217	See: Culverts	
Hollow rectangular compression members		Interconnected decks	
hoops.....	5-157	panels parallel to traffic.....	9-32
limitations on the use of the rectangular		panels perpendicular to traffic.....	9-32
stress block method.....	5-54	Interface shear transfer—shear friction	
reinforcement.....	5-156	cohesion and friction factors.....	5-82
splices.....	5-156	computation of factored interface shear	
ties.....	5-156	force.....	5-80
wall slenderness ratio.....	5-53	minimum area of interface shear	
Hooks and bends		reinforcement.....	5-83
basic hook development length.....	5-163	Interior beams	
hooked-bar tie requirements.....	5-164	distribution of load.....	4-35, 4-38, 4-42
minimum bend diameters.....	5-110	Laboratory tests	
modification factors.....	5-162	rock properties.....	10-11
seismic hooks.....	5-110	soil properties.....	10-11
standard hooks.....	5-110	Lap splices	
Horizontal wind pressure		in compression.....	5-172
on structures.....	3-41	general requirements.....	5-170

- in tension 5-171
- Large deflection theory 4-12
 - approximate methods 4-13
 - refined methods 4-16
- Lateral bracing
 - See also: Bracing, Diaphragms and cross-frames
 - aluminum structures 7-22, 7-55
 - I-section members 6-65
 - through-spans 7-22
 - trusses 6-68
 - tub section members 6-66
- Lateral buckling
 - equations for 6-319
- Lateral clearance, sound barrier 15-2
- Lateral torsional buckling resistance 6-144, 6-279
- Lightweight concrete
 - coefficient of thermal expansion 5-15
 - compressive strength 5-13
 - creep 5-15
 - modifications for 5-59
 - modulus of elasticity 5-17
 - modulus of rupture 5-18
 - Poisson's ratio 5-18
 - shrinkage 5-17
 - tensile strength 5-19
 - unit weight 3-16
- Limit states
 - See: Extreme event limit states, Fatigue and fracture limit states, Service limit states, Strength limit states
- Live loads
 - application 3-25
 - braking force 3-32
 - centrifugal forces 3-32
 - deck overhang load 3-28
 - decks, deck systems, top slabs of box culverts 3-27, 4-68
 - design lane load 3-24
 - design tandem 3-24
 - design truck 3-23
 - distribution of wheel loads through earth
 - fills 3-25
 - gravity loads 3-17
 - live load deflection 3-26
 - multiple box sections 6-178
 - multiple presence 3-18
 - reinforced concrete pipe 12-52
 - steel tunnel liner plate 12-88
 - tire contact area 3-24
 - vehicular collision force 3-35
- Load factors 3-8
 - buried structures 12-9
 - combinations 3-8, 3-15
 - construction loads 3-15, 5-213, 5-226, 5-229
 - definition 1-2
 - jacking 3-16
 - modular bridge joint systems 14-25
 - post-tensioning 3-16
- Load indicator devices 6-27
- Load-induced fatigue
 - application 6-32, 7-12
 - design criteria 6-33, 7-12
 - detail categories 6-34, 7-12
 - detailing to reduce constraint 6-48
 - fatigue resistance 6-48, 7-16
- Local buckling
 - steel 6-143, 6-278
- Local zone 5-124
 - bearing resistance 5-143
 - dimensions of 5-142
 - responsibilities 5-125
 - special anchorage devices 5-129
- Location features
 - bridge site arrangement 2-4
 - clearances 2-6
 - environment 2-7
 - route location 2-3
- Long-slotted holes 6-217, 7-51
- Long-span structural plate structures 12-26
 - acceptable special features 12-29
 - backfill protection 12-38
 - balanced support 12-35
 - concrete relieving slabs 12-36
 - construction and installation 12-37
 - construction requirements 12-31
 - continuous longitudinal stiffeners 12-29
 - cross-section 12-27
 - cut-off (toe) walls 12-36
 - end treatment design 12-33
 - footing design 12-31
 - footing reactions in arch structures 12-30
 - foundation design 12-29
 - hydraulic protection 12-35
 - hydraulic uplift 12-36
 - mechanical and chemical requirements 12-28
 - reinforcing ribs 12-29
 - safety against structural failure 12-25, 12-27, 12-29, 12-33
 - scour 12-36
 - seam strength 12-29
 - section properties 12-27
 - service limit state 12-27
 - service requirements 12-32
 - settlement limits 12-29
 - shape control 12-28
 - soil envelope design 12-31
 - standard shell end types 12-33
 - thrust 12-29
 - wall area 12-29
- Longitudinal stiffeners 6-166
 - limiting slenderness ratio 6-82
 - long-span structural plate structures 12-29
 - moment of inertia and radius of gyration 6-169
 - projecting width 6-169
- Loss of prestress
 - approximate estimate of time-dependent losses 5-103

creep	5-108, 5-114	metal grid decks	9-16
instantaneous losses	5-98	open grid floors	9-16
losses for deflection calculations	5-109	orthotropic aluminum decks	9-28
refined estimate	5-104	orthotropic steel decks	9-20
relaxation	5-106	superposition of local and global effects	9-25
shrinkage	5-105, 5-108	Metal fasteners and hardware	8-21
total	5-98	corrosion protection	8-23
Maintenance access to sound barriers	15-2	drift pins and bolts	8-22
Materials		fasteners	8-21
adjustment factors for reference design		minimum requirements	8-21
values	8-24	nails and spikes	8-22
alternative fasteners	6-27	prestressing bars	8-21
aluminum castings	7-7	shear plate connectors	8-22
aluminum forgings	7-7	spike grids	8-22
aluminum pipe and structural plate		split ring connectors	8-22
structures	12-7	toothed metal plate connectors	8-22
aluminum sheet, plate, and shapes	7-3	Metal pipe, pipe arch, and arch structures	12-24
bolts, nuts, and washers	6-25	construction and installation	12-26
bronze or copper alloy sliding surfaces	14-76	corner backfill for corner pipe arches	12-19
cables	6-28	flexibility limits and construction	
cast metal	6-28	stiffness	12-12
concrete	5-12, 12-7	handling and installation requirements	12-25
deck joints	14-14	resistance to buckling	12-25
disc bearings	14-77	safety against structural failure	12-24
fasteners—rivets and bolts	7-6	seam resistance	12-25
glued laminated timber	8-12	section properties	12-24
guides and restraints	14-79	smooth lined pipe	12-26
load indicator devices	6-25	stiffening elements for structural plate	
metal fasteners and hardware	8-21	structures	12-26
pins, rollers, and expansion rockers	7-6	thrust	12-24
pins, rollers, and rockers	6-25	Methods of analysis	
pot bearings	14-51	See: Dynamic analysis, Mathematical	
precast concrete pipe	12-7	modeling, Physical model analysis, Static	
precast concrete structures	12-7	analysis	
precast reinforced concrete three-sided		Modular bridge joint systems (MBJS)	14-22
structures	12-91	design stress range	14-31
preservative treatment	8-23	distribution of wheel loads	14-27
prestressing steel	5-22	fatigue limit state design requirements	14-29
railings	13-5	loads and load factors	14-25
sawn lumber	8-5	performance requirements	14-24
stainless steel	6-28	strength limit state design requirements	14-28
steel pipe and structural plate structures	12-8	testing and calculation requirements	14-25
steel reinforcement	12-7	Modulus of elasticity	
structural steels	6-22	concrete	5-18
stud shear connectors	6-27	reinforcing steel	5-19
thermoplastic pipe	12-7	wood piles	8-21
weld metal	6-27, 7-7	Modulus of rupture	5-18
wood products	8-5	Moment redistribution	
Mathematical modeling	4-10	concrete	5-47
equivalent members	4-16	from interior-pier I-sections in straight	
geometry	4-12	continuous-span bridges	6-283, 6-287
modeling boundary conditions	4-16	Mononobe-Okabe analysis	11-110
structural material behavior	4-11	MSE walls	11-54
Mechanically stabilized earth walls		abutments	11-99
See: MSE walls		bearing resistance	11-64
Metal decks		boundary between active and resistant	
corrugated	9-29	zones	11-70
filled and partially filled grid decks	9-17	concentrated dead loads	11-95
limit states	9-25	corrosion issues for facing	11-60

- design life considerations 11-76
- design tensile resistance 11-80
- drainage 11-94
- dynamic load allowance 3-31
- earth pressure 3-117
- external stability 11-62, 11-86
- facing 11-58
- facing reinforcement connections 11-82
- flexible wall facings 11-59
- geosynthetic reinforcements 11-78, 11-80, 11-82
- hydrostatic pressures 11-98
- internal stability 11-65, 11-87
- lateral displacement 11-61
- loading 11-60, 11-63, 11-65
- maximum reinforcement loads 11-66
- minimum front face embedment 11-58
- minimum length of soil reinforcement 11-57
- obstructions in the reinforced soil zone 11-98
- overall stability 11-61
- overturning 11-64
- reinforcement/facing connection design
 - strength 11-82
- reinforcement loads at connection to wall
 - face 11-70
- reinforcement pullout 11-70
- reinforcement strength 11-74
- safety against soil failure 11-62
- safety against structural failure 11-65
- seismic design 11-86
- settlement 11-60
- sliding 11-64
- special loading conditions 11-95
- steel reinforcements 11-76, 11-80, 11-82
- stiff or rigid concrete, steel, and timber
 - facings 11-59
- structure dimensions 11-56
- subsurface erosion 11-94
- traffic loads and barriers 11-96
- Multimode spectral analysis method 4-85
- Multiple presence of live load 3-18
- Multispan bridges
 - multimode spectral method of analysis 4-85
 - selection of method 4-81
 - single-mode method of analysis 4-82
 - single-mode spectral method of analysis 4-82
 - time-history method of analysis 4-85
 - uniform load method of analysis 4-83
- Net area
 - aluminum 7-24
 - steel 6-77
- Noncompact sections
 - nominal flexural resistance 6-140, 6-188
- Noncomposite sections
 - box-shaped members 6-202
 - builtup members 6-78
 - channels, angles, tees, and bars 6-205, 6-207, 6-209
 - circular tubes 6-204
 - I- and H-shaped members 6-201
 - nominal compressive resistance 6-82
 - rectangular bars and solid rounds 6-210
 - tees and double angles 6-205
- Nondestructive testing
 - aluminum 7-19
- Nonyielding abutments 11-100
- Nordlund/Thurman method 10-103
- Nuts
 - grade and finish of 7-50
 - materials 6-26
- Operational importance 1-7
- Orthotropic aluminum decks
 - approximate analysis 9-29
 - limit states 9-29
- Orthotropic deck superstructures 6-247
 - decks in global compression 6-247
 - effective width of deck 6-249
 - superposition of global and local effects 6-249
- Orthotropic decks
 - See: Orthotropic aluminum decks;
 - Orthotropic steel decks
- Orthotropic steel decks
 - approximate analysis 9-21
 - closed ribs 9-24, 9-26
 - deck and rib details 9-27
 - design 9-23
 - detailing requirements 9-26
 - effective flange width 4-54
 - load-induced fatigue 6-32
 - minimum plate thickness 9-26
 - refined analysis 9-21
 - unauthorized welding 9-27
 - wearing surface 9-20
 - wheel load distribution 9-20
- Oversize holes 6-217, 7-51
- Parapets
 - See: Railings
- PE pipes
 - See: Plastic
- Pedestrian loads 3-30
- Pedestrian railings
 - design live loads 13-10
 - geometry 13-9
- Perforated plates 6-78, 6-94
- Permanent loads 3-16
 - dead loads 3-16
 - earth loads 3-17
- Physical model analysis
 - bridge testing 4-90
 - scale model testing 4-90
- Piers
 - barge collision force 3-154
 - collision protection 11-34
 - collision walls 11-34
 - facing 11-34
 - ice loads 3-44, 3-50
 - load combinations and load factors 11-10
 - load effects 11-33

longitudinal reinforcement of hollow rectangular precast segmental piers	5-230	wave equation analysis	10-98
protection	11-34	Pin-connected plates	6-79
scour	11-34	packing	6-80
seismic design	5-147	pin plates	6-79
service limit state	11-6	proportions	6-80
ship collision force	3-151	Pins	
Pile bents	3-97	location	6-68
Piles		materials	6-25
See also: Concrete piles, Steel piles,		minimum size pin for eyebars	6-69
Wood piles		pins and pin nuts	6-70
α -method	10-101	resistance	6-69
axial resistance change after pile driving	10-93	Pipe arch structures	
batter piles	10-82	See: Metal pipe, pipe arch, and arch structures	
β -method	10-102	Pipes	
buckling and lateral stability	10-118	flexibility factor	12-12
buoyancy	10-94	Plank decks	
corrosion and deterioration	10-119	See: Wood decks and deck systems	
design requirements	10-82	Plastic	
determination of R_{ndr}	10-121	polyethylene (PE) pipes	12-8, 12-102
downdrag	10-83, 10-95	polyvinyl chloride (PVC) pipes	12-8, 12-103
drivability analysis	10-121	Plastic hinges	4-80
driven to hard rock	10-90	Plastic moment	6-313, 6-318
driven to soft rock	10-90	Polytetrafluorethylene sliding surfaces	
dynamic formula	10-99	See: PTFE sliding surfaces	
dynamic testing	10-97	Portal and sway bracing	6-246, 7-56
extreme event limit state	10-118	deck truss spans	6-246
λ -method	10-102	through-truss spans	6-246
groundwater effects	10-94	Post-and-beam railings	13-21, 13-26
horizontal pile foundation movement	10-87	Post-tensioned anchorage zones	5-122
length estimates for contract documents	10-91	application of the strut-and-tie model to	
load determination	10-83	the design of general zone	5-132
minimum pile penetration	10-120	approximate stress analyses and design	5-137
minimum pile spacing, clearance, and		bursting forces	5-140
embedment into cap	10-81	compressive stresses	5-138
nearby structures	10-84	design of general zone	5-125
Nordlund/Thurman method in		design of local zones	5-142
cohesionless soils	10-103	edge tension forces	5-141
piles through embankment fill	10-82	elastic stress analysis	5-136
point bearing piles on rock	10-90	general zone and local zone	5-123
relaxation	10-93	limitations of application	5-137
resistance factors	10-38	Pot bearings	14-51
resistance of pile groups in compression ...	10-112	elastomeric disc	14-53
scour	10-94	geometric requirements	14-51
service limit state	10-84	materials	14-51
settlement	10-84	movements and loads	14-15, 14-16
setup	10-93	piston	14-55
special requirements	10-167	pot	14-54
static analysis	10-100	sealing rings	14-53
static load test	10-97	Precast beams	
strength limit state	10-29, 10-89	bridges composed of simple span precast	
structural resistance	10-117	girders made continuous	5-201
test piles	10-123	concrete strength	5-198
tip resistance in cohesive soils	10-103	detail design	5-197
tolerable movements	10-84	extreme dimensions	5-197
uplift	10-114	lifting devices	5-197
uplift due to expansive soil	10-83	preservice conditions	5-197
using SPT or CPT in cohesionless soils	10-108	Precast deck bridges	5-234
		cast-in-place closure joint	5-236

- design 5-235
- longitudinal construction joints 5-235
- longitudinally post-tensioned precast
 - decks 9-15
 - post-tensioning 5-235
 - shear-flexure transfer joints 5-236
 - shear transfer joints 5-235
 - structural overlay 5-236
 - transversely joined precast decks 9-14
- Precast prestressed piles
 - concrete quality 5-192
 - pile dimensions 5-192
 - reinforcement 5-193
- Precast reinforced concrete three-sided
 - structures 12-91
 - concrete 12-91
 - concrete cover for reinforcement 12-91
 - crack control 12-93
 - deflection control at the service limit
 - state 12-93
 - design 12-91
 - distribution of concentrated load effects
 - in top slab and sides 12-92
 - distribution of concentrated loads in
 - skewed culverts 12-92
 - footing design 12-93
 - geometric properties 12-91
 - materials 12-91
 - minimum reinforcement 12-93
 - reinforcement 12-91
 - resistance factors 12-93
 - scour protection and waterway
 - considerations 12-93
 - shear transfer in transverse joints
 - between culvert sections 12-92
 - span length 12-92
 - structural backfill 12-93
- Precast reinforced piles
 - pile dimensions 5-192
 - reinforcing steel 5-192
- Prefabricated modular walls 11-102
 - See also: Earth pressure
 - abutments 11-105
 - bearing resistance 11-102
 - drainage 11-105
 - dynamic load allowance 3-31
 - loading 11-102
 - module members 11-103
 - movement at the service limit state 11-102
 - overturning 11-103
 - passive resistance and sliding 11-103
 - safety against soil failure 11-102
 - safety against structural failure 11-103
 - seismic design 11-104
 - sliding 11-102, 11-103
 - subsurface erosion 11-103
- Preservative treatment for wood
 - fire retardant treatment 8-24
 - inspection and marking 8-24
 - requirement for 8-23
 - treatment chemicals 8-23
- Prestressed concrete
 - See also: Prestressing steel
 - buckling 5-91
 - crack control 5-91
 - loss of prestress 5-98
 - section properties 5-91
 - specified concrete strengths 5-91
 - stress limitations for prestressing tendons 5-92
 - stresses due to imposed deformation 5-92
 - tendons with angle points or curves 5-91
- Prestressing steel
 - concrete cover 5-175
 - materials 5-20
 - modulus of elasticity 5-21
 - post-tensioning anchorages and couplers 5-21
 - stress at nominal flexural resistance 5-40
- Prestressing strand
 - bonded 5-168
 - partially debonded 5-169
- Prestressing tendons
 - protection for 5-176
- Pretensioned anchorage zones
 - confinement reinforcement 5-146
 - factored bursting resistance 5-149
- Probability of aberrancy
 - approximate method 3-143
 - statistical method 3-143
- Protective coatings 5-176
 - See: Corrosion protection
- Provisional post-tensioning ducts and
 - anchorages 5-219
 - bridges with internal ducts 5-219
 - provision for future dead load or
 - deflection adjustment 5-219
- Provisions for structure types
 - arches 5-231, 7-56
 - beam and girder framing 7-55
 - beams and girders 5-196
 - culverts 5-236
 - floor system 7-55
 - lateral bracing 7-55
 - orthotropic deck superstructures 6-247
 - segmental construction 5-211
 - slab superstructures 5-232
 - solid web arches 6-249
 - through-girder spans 6-250
 - trusses 6-244, 7-55
- PTFE sliding surfaces 14-44
 - attachment 14-48
 - coefficient of friction 14-47
 - contact pressure 14-46
 - mating surface 14-45, 14-48
 - minimum thickness 14-45
 - PTFE surface 14-44
 - stainless steel mating surfaces 14-46

PVC pipes	
See: Plastic	
Railing design	
protection of users	2-5
railing test specimens.....	13-19
Railings.....	13-3
See also: Bicycle railings, Combination railings, Pedestrian railings, Traffic railings	
concrete parapet and metal rail	13-22
extreme event limit state.....	13-5
materials	13-5
post-and-beam railings	13-21, 13-26
strength limit state	13-5
wood barriers.....	13-24
Railroads	
rail transit load.....	3-30
Rectangular stress block method	5-54
Redundancy	1-6
Refined methods of analysis	4-16, 4-68
arch bridges	4-73
beam-slab bridges.....	4-70
cable-stayed bridges	4-73
cellular and box bridges.....	4-72
decks.....	4-67
fatigue load	3-28
nominal moment-rotation curves.....	6-292
orthotropic steel decks	9-21
suspension bridges.....	4-74
truss bridges.....	4-72
Reinforced concrete pipe	12-47
bearing resistance	12-61
bedding factor	12-62
circumferential reinforcement	12-55
concrete cover.....	12-58
construction and installation.....	12-65
crack width control	12-57
development of quadrant mat reinforcement.....	12-65
direct design method.....	12-53
flexural resistance	12-55
indirect design method.....	12-61
live loads.....	12-52
loading	12-48
loads and pressure distribution	12-53
maximum flexural reinforcement without stirrups.....	12-56
minimum reinforcement	12-55
pipe fluid weight.....	12-52
pipe ring analysis.....	12-54
process and material factors.....	12-55
safety against structural failure.....	12-52
service limit state.....	12-52
shear resistance	12-58, 12-60
standard installations	12-48
stirrup anchorage	12-61
stirrup embedment	12-61
stirrup reinforcement anchorage	12-61
Reinforcement	
See also: Spacing of reinforcement	
abutments and retaining walls	11-18
approximate stress analyses and design.....	5-137
cast-in-place girders and box and T-beams	5-210
compression members	5-48
concrete cover.....	5-110, 5-175
crack control	5-34, 5-91
drilled shafts	10-142, 10-143
elastic stress analysis	5-136
elastomeric bearings	14-64, 14-75
external tendon supports.....	5-119
hollow rectangular compression members	5-156
hooks and bends	5-110
longitudinal.....	5-75, 5-77
materials	5-18
maximum reinforcement.....	5-43
minimum reinforcement	5-43
post-tensioned anchorage zones	5-122
pretensioned anchorage zones	5-144
shrinkage and temperature.....	5-121
spacing of.....	5-111
special applications.....	5-20
spirals and ties	5-53
tendon confinement	5-114
torsional	5-88
transverse..	5-62, 5-77, 5-119, 5-121, 5-150, 5-151
Reinforcing steel	
See: Reinforcement	
Relaxation losses	
after transfer.....	5-107
at transfer.....	5-106
Relieving slabs	
long-span structural plate structures	12-86
structural plate box structures.....	12-46
Resistance factors	
abutments, piers, and walls.....	11-6, 11-13, 11-16
aluminum structures	7-10
buried structures	12-10
compression members	5-51
concrete structures	5-147
conventional construction.....	5-26
drilled shafts	10-47
driven piles	10-39
footings	5-187
foundations	10-38
precast reinforced concrete three-sided structures	12-93
segmental construction	5-28
seismic zones 3 and 4	5-149
spread footings.....	10-39
steel.....	6-30
Retaining walls	
See: Abutments and retaining walls	
Rigid frame connections	6-243
Roadway drainage	
design storm.....	2-24
discharge from deck drains.....	2-25

- drainage of structures 2-25
- type, size, and number of drains 2-24
- Rock bearing resistance 10-77
- analytic method 10-78
- load test 10-78
- semiempirical procedures 10-78
- Rock properties
- erodability 10-27
- geophysical tests 10-12
- in-situ tests 10-11
- informational needs 10-7
- laboratory tests 10-11
- mass deformation 10-25
- mass strength 10-21
- selection of design properties 10-13
- Rocker bearings 14-42
- contact stresses 14-43
- geometric requirements 14-43
- materials 6-25, 14-43
- Roller bearings 14-42
- contact stresses 14-43
- geometric requirements 14-43
- materials 6-25, 14-43
- Route location 2-3
- waterway and floodplain crossings 2-3
- Safety
- See also: Traffic safety
- abutments and retaining walls 11-23
- anchored walls 11-45, 11-49
- cantilevered retaining walls 11-35, 11-36
- design objective 2-7
- MSE walls 11-62, 11-65
- prefabricated modular walls 11-102, 11-103
- Sawn lumber
- See also: Wood
- bracing 8-36
- dimensions 8-6
- moisture content 8-6
- reference design values 8-6
- size factor 8-26
- Scale model testing 4-90
- Scour 2-21
- buried structures 12-19
- change in foundations 3-39
- drilled shafts 10-130
- piers 11-34
- piles 10-94
- Sealing rings
- rings with circular cross-sections 14-53
- rings with rectangular cross-sections 14-53
- Sectional design model
- combined shear and torsion 5-77
- longitudinal reinforcement 5-75, 5-77
- nominal shear resistance 5-67
- procedures for determining shear
- resistance 5-68
- sections near supports 5-65
- Segmental bridge analysis
- analysis of the final structural system 5-212
- effective flange width 4-65
- erection analysis 4-66
- final structural system 4-66
- longitudinal analysis 4-66
- strut-and-tie models 4-65
- transverse analysis 4-66
- Segmental bridge design
- deck joints 9-15
- principal stresses in webs 5-84
- Segmental bridge substructures
- design 5-235
- Segmental construction 5-211
- alternative construction methods 5-228
- analysis of segmental bridges 5-212
- box girder cross-section dimensions and
- details 5-220
- cantilever construction 5-225
- construction analysis 5-225
- construction loads 5-213, 5-215, 5-226, 5-229
- creep and shrinkage 5-217
- design 5-213
- design details 5-227
- design of construction equipment 5-228
- details for cast-in-place construction 5-225
- details for precast construction 5-223
- force effects due to construction
- tolerances 5-226
- incrementally launched construction 5-226
- plan presentation 5-219
- prestress losses 5-218
- provisional post-tensioning ducts and
- anchorage 5-219
- seismic design 5-222
- span-by-span construction 5-225
- substructures 5-217
- thermal effects during construction 5-217
- types of segmental bridges 5-223
- Seismic design
- abutments and retaining walls 11-23
- anchored walls 11-51
- bearings 14-40, 14-75
- cantilevered retaining walls 11-23
- column connections 5-155
- concrete piles 5-191, 5-192
- construction joints in piers and columns 5-155
- elastomeric bearings 14-66
- hold-down devices 3-98
- lateral load distribution 4-63
- MSE walls 11-86
- prefabricated modular walls 11-104
- segmental construction 5-211
- seismic zone 1 5-148
- seismic zone 2 5-148
- seismic zones 3 and 4 5-149
- wall-type piers 5-154
- Seismic loads
- acceleration coefficient 3-54
- combination of seismic force effects 3-92
- design of bridge components 3-167

dynamic analysis.....	4-77	structural plate box structures.....	12-41
elastic seismic response coefficient.....	3-90	wood structures.....	8-33
forces resulting from plastic hinging.....	3-91	Serviceability	
longitudinal restrainers.....	3-98	deformations.....	2-10
minimum support length requirements.....	4-85	durability.....	2-8
multispan bridges.....	4-78	inspectability.....	2-9
operational classification.....	3-90	maintainability.....	2-9
<i>P</i> - Δ requirements.....	4-86	rideability.....	2-9
requirements for temporary bridges and		utilities.....	2-9
stage construction.....	3-98	widening.....	2-14
response modification factors.....	3-91	Settlement	
seismic hazard.....	3-54, 3-89	buried structures.....	12-14
seismic zone 1.....	3-93	cohesionless soils.....	10-58
seismic zone 2.....	3-94	cohesive soils.....	10-58, 10-86
seismic zones 3 and 4.....	3-94	downdrag.....	10-95
single-span bridges.....	4-78	due to downdrag.....	10-130
site effects.....	3-84	equivalent footing analogy.....	10-84
Seismic zone 1.....	3-93, 5-148	force effects.....	3-138
Seismic zone 2.....	3-94, 5-148	group settlement.....	10-130
Seismic zones 3 and 4		intermediate geo materials.....	10-129
column and pile bent design forces.....	3-97	on rock.....	10-63
column connections.....	5-155	single-drilled shaft.....	10-127
column requirements.....	5-149	Shear and torsion	
concrete piles.....	5-191	aluminum.....	7-40, 7-45
construction joints in piers and columns.....	5-155	beam ledges.....	5-177
foundation design forces.....	3-97	concrete.....	5-56, 5-63
inelastic hinging forces.....	3-94	design and detailing requirements.....	5-62
modified design forces.....	3-94	development of reinforcement.....	5-160
pier design forces.....	3-97	interface shear transfer—shear friction.....	5-78
piers with two or more columns.....	3-96	interior-pier I-sections in straight	
resistance factors.....	5-26	continuous-span bridges.....	6-285
single columns and piers.....	3-95	longitudinal reinforcement.....	5-77
wall-type piers.....	5-154	modifications for lightweight concrete.....	5-59
Service limit states.....	1-3	nominal shear resistance.....	5-67
abutments and retaining walls.....	11-6, 11-19	sectional design model.....	5-64
aluminum structures.....	7-7	segmental box girder bridges.....	5-85
bridges composed of simple span		shear in slabs and footings.....	5-188
precast girders made continuous.....	5-201	skewed bridges.....	4-40
buried structures.....	12-9, 12-14	steel.....	6-151
cast-in-place box culverts and		torsional resistance.....	5-77
arches.....	12-71	transfer and development lengths.....	5-60
concrete structures.....	5-23, 5-35, 5-95	transverse reinforcement.....	5-60, 5-77
decks.....	9-5	in tubes.....	7-49
drilled shafts.....	10-126	warping torsion.....	7-47
flexure.....	6-286	Shear connectors.....	6-136, 6-154
foundations.....	10-27, 10-28, 10-29	cover and penetration.....	6-157
interior-pier I-sections in straight		fatigue resistance.....	6-157
continuous-span bridges.....	6-286	permanent load contraflexure.....	6-158
lateral squeeze.....	10-89	pitch.....	6-155
long-span structural plate structures.....	12-27	steel box-section flexural members.....	6-194
orthotropic aluminum decks.....	9-26	strength limit state.....	6-158
piers.....	11-6	studs.....	6-27
piles.....	10-84	transverse spacing.....	6-156
redistribution moments.....	6-287	Shear resistance	
reinforced concrete pipe.....	12-52	aluminum.....	7-40
sound barriers.....	15-3	bolted connections.....	6-220
steel box-section flexural members.....	6-182	disc bearings.....	14-73
steel I-section members.....	6-127	reinforced concrete pipe.....	12-58, 12-60
steel structures.....	6-29	steel box-section flexural members.....	6-194

- steel I-section flexural members.....6-151
- wood.....8-31
- Ship collision force
 - See: Vessel collisions
- Short-slotted holes..... 6-217, 7-51
- Shrinkage..... 3-137, 5-17
- Sidewalks 13-12
 - end treatment of separation railing..... 13-13
- Skewed bridges
 - live load distribution..... 4-32, 4-47
- Slab superstructures
 - cast-in-place solid slab superstructures5-231
 - cast-in-place voided slab
 - superstructures5-232
 - precast deck bridges5-234
- Slabs
 - See: Concrete slabs
- Slenderness effects and limits
 - compression members5-51
 - ice loads, piers3-50
- Slenderness ratios
 - aluminum.....7-20
 - steel 6-77, 6-82
- Slip-critical connections 6-214, 7-53
- Slip resistance
 - bolted connections.....6-221
- Small deflection theory.....4-12
- Soil bearing resistance.....10-66
 - basic formulation.....10-67
 - considerations for footings in slopes.....10-71
 - considerations for punching shear.....10-70
 - considerations for two-layer soil
 - systems—critical depth10-73
 - plate load tests10-77
 - semiempirical procedures.....10-76
 - theoretical estimation10-67
 - two-layered soil system in drained
 - loading.....10-76
 - two-layered soil system in undrained
 - loading.....10-74
- Soil properties
 - determination of 11-5, 12-6, 15-12
 - envelope backfill soils12-6
 - foundation soils12-6
 - geophysical tests.....10-12
 - in-situ tests10-11
 - informational needs10-7
 - laboratory tests10-11
 - selection of design properties10-13
 - soil deformation.....10-18
 - soil strength10-15
 - subsurface exploration.....10-8
 - unit weight.....3-17
- Soil strength
 - drained strength of cohesive soils.....10-16
 - drained strength of granular soils10-16
 - undrained strength of cohesive soils.....10-15
- Soil-structure interaction systems
 - See: Culverts
- Solid web arches
 - flange stability6-250
 - moment amplification for deflection6-249
 - web slenderness.....6-249
- Sound barriers
 - corrosion protection.....15-13
 - design limit states15-12
 - drainage 15-2, 15-14
 - earth load15-9
 - extreme event limit state.....15-4
 - foundation design15-12
 - loading.....15-13
 - resistance factors15-13
 - safety against geotechnical failure.....15-13
 - seismic design15-13
 - service limit state.....15-3, 15-13
 - soil and rock properties15-12
 - strength limit state15-3, 15-13
 - wind load15-5
 - vehicle collision forces15-9
- Spacing of reinforcement
 - bundled bars5-112
 - cast-in-place concrete5-111
 - couplers in post-tensioning tendons5-114
 - curved post-tensioning ducts5-113
 - hollow rectangular compression
 - members5-156
 - maximum spacing of reinforcing bars5-112
 - minimum spacing of prestressing tendons
 - and ducts5-112
 - minimum spacing of reinforcing bars.....5-111
 - multilayers5-111
 - post-tensioning ducts straight in plan5-113
 - precast concrete5-111
 - pretensioning strand5-112
 - splices5-112
- Spike laminated decks9-38
 - deck tie-downs.....9-39
 - panel decks9-39
- Splices
 - See also: Bolted splices, Splices of bar reinforcement, Splices of welded wire fabric
 - compression members7-54
 - flexural members.....7-54
 - tension members.....7-54
 - welded6-248
 - welding7-55
- Splices of bar reinforcement
 - See also: Lap splices
 - bars in compression5-172
 - detailing5-170
 - end-bearing splices5-173
 - general requirements5-170
 - mechanical connections.....5-171
 - mechanical connections or welded
 - splices in compression.....5-172

mechanical connections or welded		modulus of elasticity.....	6-22
splices in tension	5-172	thickness of metal	6-22
reinforcement in tension	5-171	Steel box-section flexural members.....	6-171
tension tie members.....	5-172	access and drainage	6-177
welded splices.....	5-171	bearings	6-176
Splices of welded wire fabric		compact sections.....	6-187
deformed wire in tension	5-173	constructibility	6-179
smooth wire in tension.....	5-173	cross-section proportion limits	6-177
Spread footings	10-51	fatigue and fracture limit state	6-183
anchorage of inclined footings.....	10-53	flange-to-web connections.....	6-176
bearing depth	10-51	flexural resistance—sections in negative	
bearing resistance at the service limit		flexure.....	6-189
state.....	10-64	flexural resistance—sections in positive	
bearing stress distributions	10-52	flexure.....	6-187
eccentric load limitations.....	10-81	noncompact sections.....	6-187
effective footing dimensions.....	10-52	service limit state	6-182
extreme event limit state.....	10-80	shear connectors	6-194
failure by sliding.....	10-79	shear resistance	6-194
groundwater.....	10-53	stiffeners	6-195
loads.....	10-54	strength limit state	6-185
nearby structures.....	10-53	stress determination	6-173
overall stability	10-64	Steel dimension and detail requirements	
resistance factors.....	10-38	dead load camber	6-57
service limit state	10-53	diaphragms and cross-frames	6-57
settlement on cohesionless soils	10-55	effective length of span.....	6-57
settlement on cohesive soils.....	10-58	heat-curved rolled beams and welded	
settlement on rock.....	10-63	plate girders	6-70
strength limit state	10-38, 10-66	lateral bracing	6-65
structural design.....	10-81	minimum thickness of steel	6-59
tolerable movements.....	10-53	pins	6-68
uplift	10-53	Steel I-girders	
St. Venant torsion		See: Steel I-section flexural members	
aluminum.....	7-46	Steel I-section flexural members	
Stability		compact sections.....	6-136
buried structures	12-17	composite sections.....	6-102
elastomeric bearings	14-63, 14-75	constructibility	6-120
MSE walls	11-60, 11-62, 11-65, 11-86, 11-87	cover plates.....	6-170
sound barriers	15-13	cross-section proportion limits	6-118
static analysis.....	4-75	diaphragms or cross-frames	6-59
Stainless steel.....	6-28	ductility requirement.....	6-140
Static analysis		fatigue and fracture limit state	6-130
analysis for temperature gradient.....	4-75	flange-strength reduction factors	6-113
approximate methods.....	4-19	flange stresses and member bending	
axial pile resistance in compression.....	10-93	moments	6-106
influence of plan geometry	4-17	flexural resistance.....	6-136, 6-141
redistribution of negative moments in		flexural resistance—composite sections	
continuous beam bridges	4-74	in negative flexure and	
refined methods	4-68	noncomposite sections.....	6-139
stability	4-75	flexural resistance—composite sections	
Stay-in-place formwork		in positive flexure.....	6-136
concrete.....	9-13	flowcharts for design	6-300
deck overhangs	9-5	fundamental calculations	6-313
steel.....	9-13	hybrid sections.....	6-104
Steel		lateral bracing	6-60
basic steps for steel bridge		minimum negative flexure concrete deck	
superstructures.....	6-295	reinforcement.....	6-108
coefficient of thermal expansion	6-22	moment redistribution from interior-pier	
minimum mechanical properties by		I sections in straight continuous-	
shape, strength, and thickness.....	6-25	span bridges.....	6-283

- net section fracture 6-110
- noncompact sections 6-139, 6-140
- noncomposite sections 6-103
- service limit state 6-127
- shear connectors 6-154
- shear resistance 6-151
- stiffeners 6-161
- stiffness 6-106
- strength limit state 6-131
- variable web depth members 6-104
- web bend-buckling resistance 6-110
- Steel I-section proportioning
 - flange proportions 6-119
 - web proportions 6-118
- Steel orthotropic decks
 - See: Orthotropic steel decks
- Steel piles 6-250
 - axial compression 6-252
 - buckling 6-252
 - combined axial compression and flexure 6-252
 - compressive resistance 6-252
 - maximum permissible driving stresses 6-252
 - structural resistance 6-250, 10-117
- Steel tension members 6-71
 - builtup members 6-78
 - eyebars 6-78
 - limiting slenderness ratio 6-77
 - net area 6-77
 - pin-connected plates 6-79
 - tensile resistance 6-72
- Steel tunnel liner plate 12-87
 - buckling 12-89
 - construction stiffness 12-89
 - earth loads 12-87
 - flexibility limits and construction
 - stiffness 12-13
 - grouting pressure 12-88
 - live loads 12-88
 - loading 12-87
 - safety against structural failure 12-88
 - seam strength 12-89
 - section properties 12-88
 - wall area 12-88
- Stiffened webs
 - nominal resistance 6-152
- Stiffeners
 - See also: Longitudinal stiffeners,
Transverse intermediate stiffeners
 - bearing stiffeners 6-165
 - design of 7-42
 - longitudinal compression-flange 6-196
 - web 6-195
- Stirrups
 - See: Transverse reinforcement
- Stream pressure
 - lateral 3-38
 - longitudinal 3-37
- Strength limit states 1-3
 - abutments and retaining walls 11-7, 11-20
 - aluminum structures 7-10
 - bridges composed of simple span precast
 - girders made continuous 5-201
 - buried structures 12-9
 - combined flexure and axial load 6-199
 - concrete structures 5-44
 - decks 9-6
 - drilled shafts 10-130
 - flexure 6-131, 6-185
 - foundations 10-29, 10-38
 - interior-pier I-sections in straight
 - continuous-span bridges 6-288
 - modular bridge joint systems 14-28
 - railings 13-5
 - resistance factors 5-26, 6-30
 - shear 6-136, 6-186, 6-200
 - shear connectors 6-136, 6-158, 6-186
 - spread footings 10-66
 - stability 5-29
 - steel box-section flexural members 6-185
 - steel structures 6-29, 6-199
 - wood structures 8-30
- Stress analyses and design
 - bursting forces 5-140
 - compressive stresses 5-138
 - edge tension forces 5-141
 - limitations of application 5-137
- Stress laminated decks 9-33
 - camber 8-37
 - deck tie-downs 9-34
 - holes in lamination 9-34
 - nailing 9-33
 - staggered butt joints 9-34
 - stressing 9-34
- Stressing
 - corrosion protection 9-38
 - design requirements 9-37
 - prestressing materials 9-36
 - prestressing system 9-34
 - railings 9-38
- Structural analysis 4-1
 - acceptable methods 4-9
 - dynamic 4-77
 - mathematical modeling 4-10
 - by physical models 4-90
 - static analysis 4-17
- Structural material behavior
 - elastic behavior 4-11
 - elastic versus inelastic behavior 4-11
 - inelastic behavior 4-11
- Structural plate box structures 12-40
 - concrete relieving slabs 12-46
 - construction and installation 12-47
 - crown soil cover factor 12-45
 - footing reactions 12-45
 - loading 12-41
 - moments due to factored loads 12-42
 - plastic moment resistance 12-44
 - safety against structural failure 12-41

service limit state	12-41	temperature range for procedure B	3-134
Structure-mounted sound barriers.....	15-4	uniform temperature	3-133
Strut-and-tie model		Thermoplastic pipes.....	12-71
crack control reinforcement.....	5-34	bending strain	12-84
general zone.....	5-132	buckling	12-81, 12-83
proportioning of compressive struts	5-31	chemical and mechanical requirements	12-73
proportioning of node regions	5-34	combined strain	12-84
proportioning of tension ties	5-33	flexibility limits and construction	
structural modeling	5-30	stiffness.....	12-13
Substructures		handling and installation requirements	12-83
construction load combinations	5-230	materials	12-8
design.....	5-222	resistance to local buckling of pipe	
longitudinal reinforcement of hollow		wall.....	12-81
rectangular precast segmental piers.....	5-230	safety against structural failure	12-73
vessel collisions	2-5, 3-156	section properties.....	12-73
Superimposed deformations		service limit state	12-71
creep	3-133	slenderness and effective width	12-82
design thermal movements	3-136	thrust.....	12-83
differential shrinkage.....	3-137	wall resistance	12-81
settlement.....	3-138	Through-girder spans.....	6-247
temperature gradient.....	3-133	Timber	
uniform temperature	3-130	See: Wood	
Superstructure design.....	5-222	Timber floors	
Surcharge loads		See: Wood decks and deck systems	
live load surcharge.....	3-129	Time-history method	4-85
point line and strip loads.....	3-124	Tire contact area	3-24
reduction of surcharge	3-130	Torsion	
strip loads—flexible walls	3-127	See: Shear and torsion	
uniform surcharge.....	3-123	Traffic railings	13-5
Suspension bridges		application of previously tested systems	13-8
refined analysis	4-72	approach railings.....	13-6
Temperature gradients	3-136, 4-75	design forces	13-17
Temporary stresses before losses		end treatment	13-6
compression stresses.....	5-93	height of traffic parapet or railing.....	13-9
tension stresses	5-93	new systems.....	13-9
Tendon confinement		railing design	13-8
effects of curved tendons.....	5-114	railing system.....	13-5
wobble effect in slabs	5-114	separation of rail elements.....	13-15
Tensile resistance		test level selection criteria	13-7
aluminum.....	7-23, 7-30	Traffic safety	
combined tension and flexure.....	6-76	geometric standards	2-5
fatigue resistance	6-225	protection of structures	2-4
MSE walls	11-62	protection of users	2-5
nominal	6-225	road surfaces.....	2-5
prying action.....	6-225	vessel collisions	2-5
reduction factor.....	6-73	Transverse intermediate stiffeners	
Tension-flange flexural resistance	6-193	moment of inertia.....	6-162
Tension members		projecting width.....	6-162
aluminum.....	7-23	Transverse reinforcement	
concrete.....	5-58	compression members	5-122, 5-120
splices	7-54	concrete.....	5-60
Tension ties		drilled shafts	10-144
anchorage of tie	5-34	flexural members	5-121
proportioning	5-33	Truss bridges	
strength of tie.....	5-33	refined analysis	4-71
Test piles.....	10-123	Trusses	6-244
Thermal forces		bracing	8-37
temperature gradient.....	3-136	camber	6-245, 8-37
temperature range for procedure A.....	3-133	diaphragms	6-59, 6-245

- factored resistance 6-247
- gusset plates 6-256
- half-through 6-257
- lateral bracing 6-64
- load distribution 4-47
- portal and sway bracing 6-246, 7-56
- secondary stresses 6-245
- truss members 6-245
- working lines and gravity axes 6-245
- Tub-section members
 - lateral bracing 6-66
- Unfilled grid decks composite with reinforced concrete slabs
 - design 9-19
 - fatigue limit state 9-19
- Unstiffened webs
 - nominal resistance 6-152
- Uplift
 - aluminum 7-19
 - buried structures 12-18
 - drilled shafts 10-126
 - load test 10-139
 - pile group uplift resistance 10-114, 10-143
 - piles penetrating expansive soil 10-83
 - resistance 10-142
 - single-pile uplift resistance 10-114
 - spread footings 10-53
- Vehicle-induced vibration 4-79
- Vehicular collision force
 - protection of structures 3-35
 - vehicle collision with barriers 3-36
- Vehicular live load
 - multiple presence of live load 3-18
 - number of design lanes 3-17
- Vertical wind pressure 3-43
- Vessel collisions 3-138
 - annual frequency of collapse 3-140
 - barge bow damage length 3-155
 - barge collision force on pier 3-154
 - damage at extreme limit state 3-155
 - design collision velocity 3-150
 - design vessel 3-140
 - impact force 3-147
 - impact force, substructure design 3-156
 - impact force, superstructure design 3-157
 - owner's responsibility 3-140
 - protection against 2-5
 - protection of substructures 3-157
 - ship bow damage length 3-153
 - ship collision force on pier 3-151
 - ship collision force on superstructure 3-153
 - ship collision with bow 3-153
 - ship collision with deck house 3-153
 - ship collision with mast 3-154
 - vessel collision energy 3-150
- Warping torsion 7-47
- Washers 6-216
 - materials 6-26
- Water loads
 - buoyancy 3-37
 - drag coefficient 3-37
 - scour 3-39
 - static pressure 3-37
 - stream pressure 3-37
 - wave load 3-39
- Wearing surface
 - chip seal 9-40
 - orthotropic steel decks 9-20
 - plant mix asphalt 9-40
 - wood decks 9-40
- Web bend-buckling resistance
 - webs with longitudinal stiffeners 6-86
 - webs without longitudinal stiffeners 6-86
- Web crippling
 - aluminum 7-9
 - steel 6-321
- Web local yielding 6-321
- Web plastification factors
 - compact web sections 6-274
 - noncompact web sections 6-275
- Web proportions
 - webs with longitudinal stiffeners 6-119, 6-178
 - webs without longitudinal stiffeners 6-118, 6-178
- Webs
 - nominal resistance of stiffened webs 6-152
 - nominal resistance of unstiffened webs 6-152
- Welded connections 6-227
 - complete penetration groove-welded connections 6-227
 - effective area 6-229
 - factored resistance 6-227
 - fillet weld end returns 6-230
 - fillet-welded 6-228
 - minimum effective length of fillet welds 6-230
 - partial penetration groove-welded connections 6-228
 - seal welds 6-230
 - size of fillet welds 6-229
- Welded wire fabric
 - deformed 5-164
 - plain 5-165
 - quadrant mat reinforcement 12-64
- Welding
 - procedures for aluminum 7-18
 - requirements for aluminum 7-18
 - splices 7-55
 - weld metal 6-27
- Wheel loads
 - corrugated metal decks 9-30
 - decks 4-27
 - distribution through earth fills 3-25
 - modular bridge joint systems 14-27
 - orthotropic steel decks 9-20
- Widening
 - exterior beams 2-14
 - substructure 2-14

Wind-induced vibration	4-79
Wind load	
aeroelastic instability	3-43
horizontal wind pressure.....	3-39
multibeam bridges	4-59
sound barriers	15-5
vertical wind pressure.....	3-43
Wind pressure on structures.....	3-41
box sections	4-63
construction	4-63
I-sections.....	4-62
loads from superstructures.....	3-41
Wind pressure on vehicles	3-42
Wood	
bracing	8-36
camber	8-37
components in combined flexure and	
axial loading	8-35
components in compression.....	8-33
components in flexure	8-31
components in tension parallel to grain	8-35
components under shear	8-33
connection design	8-37
deck factor	8-29
flat-use factor.....	8-28
format conversion factor.....	8-25
glued laminated timber	8-12
incising factor	8-29
metal fasteners and hardware.....	8-21
preservative treatment.....	8-21
sawn lumber.....	8-5
wet service factor.....	8-26
Wood barriers	
railing design	13-23
Wood decks and deck systems.....	9-30
deck tie-downs.....	9-32, 9-34, 9-39, 9-40
deformation.....	9-31
design requirements	9-30
glued laminated decks	9-32
interconnected decks.....	9-32
load distribution.....	9-30
nailing.....	9-33
noninterconnected decks.....	9-33
plank decks	9-40
shear design	9-31
skewed decks	9-31
spike laminated decks	9-38
stress laminated decks	9-33
thermal expansion.....	9-31
wearing surfaces	9-31, 9-40
Wood piles	
base resistance and modulus of elasticity	8-14
structural resistance	10-118
Yield lines.....	4-80
Yield moment	6-315
composite sections in negative flexure	6-316
composite sections in positive flexure.....	6-316
noncomposite sections.....	6-315
sections with cover plates	6-317